

P-793H v2

G.SHDSL.bis Bonded Broadband Gateway

User's Guide



Default Login Details

IP Address	http://192.168.1.1
Admin Password	1234
User Password	user

Firmware Version 3.70
Edition 1, 03/2010

www.zyxel.com

ZyXEL

About This User's Guide

Intended Audience

This manual is intended for people who want to configure the P-793H v2 using the web configurator.

Tips for Reading User's Guides On-Screen

When reading a ZyXEL User's Guide On-Screen, keep the following in mind:

- If you don't already have the latest version of Adobe Reader, you can download it from <http://www.adobe.com>.
- Use the PDF's bookmarks to quickly navigate to the areas that interest you. Adobe Reader's bookmarks pane opens by default in all ZyXEL User's Guide PDFs.
- If you know the page number or know vaguely which page-range you want to view, you can enter a number in the toolbar in Reader, then press [ENTER] to jump directly to that page.
- Type [CTRL]+[F] to open the Adobe Reader search utility and enter a word or phrase. This can help you quickly pinpoint the information you require. You can also enter text directly into the toolbar in Reader.
- To quickly move around within a page, press the [SPACE] bar. This turns your cursor into a "hand" with which you can grab the page and move it around freely on your screen.
- Embedded hyperlinks are actually cross-references to related text. Click them to jump to the corresponding section of the User's Guide PDF.

Related Documentation

- Quick Start Guide

The Quick Start Guide is designed to help you get up and running right away. It contains information on setting up your network and configuring for Internet access.

- Support Disc

Refer to the included CD for support documents.

Documentation Feedback

Send your comments, questions or suggestions to: techwriters@zyxel.com.tw

Thank you!

The Technical Writing Team, ZyXEL Communications Corp.,
6 Innovation Road II, Science-Based Industrial Park, Hsinchu, 30099, Taiwan.

Need More Help?

More help is available at www.zyxel.com.

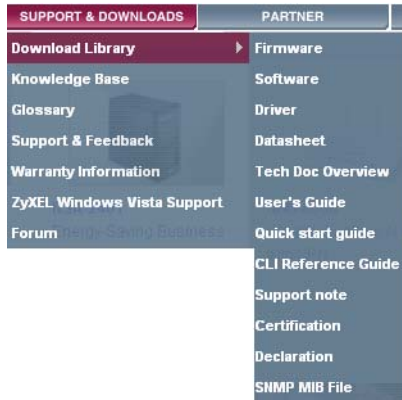

- **Download Library**

Search for the latest product updates and documentation from this link. Read the Tech Doc Overview to find out how to efficiently use the User Guide, Quick Start Guide and Command Line Interface Reference Guide in order to better understand how to use your product.

- **Knowledge Base**

If you have a specific question about your product, the answer may be here. This is a collection of answers to previously asked questions about ZyXEL products.

- **Forum**

This contains discussions on ZyXEL products. Learn from others who use ZyXEL products and share your experiences as well.

Customer Support

Should problems arise that cannot be solved by the methods listed above, you should contact your vendor. If you cannot contact your vendor, then contact a ZyXEL office for the region in which you bought the device.

See http://www.zyxel.com/web/contact_us.php for contact information. Please have the following information ready when you contact an office.

- Product model and serial number.
- Warranty Information.
- Date that you received your device.
- Brief description of the problem and the steps you took to solve it.

Disclaimer

Graphics in this book may differ slightly from the product due to differences in operating systems, operating system versions, or if you installed updated firmware/software for your device. Every effort has been made to ensure that the information in this manual is accurate.

Document Conventions

Warnings and Notes

These are how warnings and notes are shown in this User's Guide.

Warnings tell you about things that could harm you or your device.







Note: Notes tell you other important information (for example, other things you may need to configure or helpful tips) or recommendations.

Syntax Conventions

- The P-793H v2 may be referred to as the "device", the "system" or the "product" in this User's Guide.
- Product labels, screen names, field labels and field choices are all in **bold** font.
- A key stroke is denoted by square brackets and uppercase text, for example, [ENTER] means the "enter" or "return" key on your keyboard.
- "Enter" means for you to type one or more characters and then press the [ENTER] key. "Select" or "choose" means for you to use one of the predefined choices.
- A right angle bracket (>) within a screen name denotes a mouse click. For example, **Maintenance > Log > Log Setting** means you first click **Maintenance** in the navigation panel, then the **Log** sub menu and finally the **Log Setting** tab to get to that screen.
- Units of measurement may denote the "metric" value or the "scientific" value. For example, "k" for kilo may denote "1000" or "1024", "M" for mega may denote "1000000" or "1048576" and so on.
- "e.g.," is a shorthand for "for instance", and "i.e.," means "that is" or "in other words".

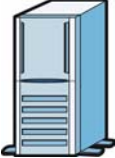
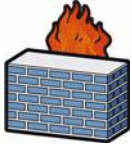
Icons Used in Figures

Figures in this User's Guide may use the following generic icons. The P-793H v2 icon is not an exact representation of your device.

P-793H v2 	Computer 	Notebook computer 
Server 	Firewall 	Telephone 
Switch 	Router 	

Safety Warnings

- Do NOT use this product near water, for example, in a wet basement or near a swimming pool.
- Do NOT expose your device to dampness, dust or corrosive liquids.
- Do NOT store things on the device.
- Do NOT install, use, or service this device during a thunderstorm. There is a remote risk of electric shock from lightning.
- Connect ONLY suitable accessories to the device.
- Do NOT open the device or unit. Opening or removing covers can expose you to dangerous high voltage points or other risks. ONLY qualified service personnel should service or disassemble this device. Please contact your vendor for further information.
- Make sure to connect the cables to the correct ports.
- Place connecting cables carefully so that no one will step on them or stumble over them.
- Always disconnect all cables from this device before servicing or disassembling.
- Use ONLY an appropriate power adaptor or cord for your device.
- Connect the power adaptor or cord to the right supply voltage (for example, 110V AC in North America or 230V AC in Europe).
- Do NOT allow anything to rest on the power adaptor or cord and do NOT place the product where anyone can walk on the power adaptor or cord.
- Do NOT use the device if the power adaptor or cord is damaged as it might cause electrocution.
- If the power adaptor or cord is damaged, remove it from the device and the power source.
- Do NOT attempt to repair the power adaptor or cord. Contact your local vendor to order a new one.
- Do not use the device outside, and make sure all the connections are indoors. There is a remote risk of electric shock from lightning.
- Do NOT obstruct the device ventilation slots, as insufficient airflow may harm your device.
- Use only No. 26 AWG (American Wire Gauge) or larger telecommunication line cord.

Your product is marked with this symbol, which is known as the WEEE mark. WEEE stands for Waste Electronics and Electrical Equipment. It means that used electrical and electronic products should not be mixed with general waste. Used electrical and electronic equipment should be treated separately.



Contents Overview

User's Guide	35
Getting To Know Your P-793H v2	37
Introducing the Web Configurator	43
Status Screens	51
Internet Setup Wizard	57
Tutorials	67
Technical Reference	73
WAN Setup	75
LAN Setup	101
Network Address Translation (NAT)	117
Firewalls	133
Content Filtering	155
VPN	161
Certificates	193
Static Route	203
802.1Q/1P	207
Quality of Service (QoS)	217
Dynamic DNS Setup	235
Remote Management	239
Universal Plug-and-Play (UPnP)	251
System Settings	263
Logs	269
Tools	283
Diagnostic	297
Introducing the SMT	301
General Setup	307
WAN Setup	311
LAN Setup	317
Internet Access Setup	321
Remote Node Setup	325
Static Route Setup	335
NAT Setup	339
.....	353
Firewall Setup	355
Filter Configuration	357
System Password	373
System Information & Diagnosis	375

Firmware and Configuration File Maintenance	387
Menus 24.8 to 24.11	403
Schedule Setup	411
Troubleshooting	415

Table of Contents

About This User's Guide	3
Document Conventions.....	6
Safety Warnings.....	8
Contents Overview	9
Table of Contents.....	11
List of Figures	23
List of Tables.....	31
Part I: User's Guide.....	35
Chapter 1	
Getting To Know Your P-793H v2	37
1.1 Overview	37
1.1.1 High-speed Internet Access with G.SHDSL	37
1.1.2 High-speed Point-to-point Connections	38
1.1.3 High-speed Point-to-2points Connections	38
1.2 Ways to Manage the P-793H v2	39
1.3 Good Habits for Managing the P-793H v2	40
1.4 LEDs	40
1.5 The RESET Button	41
1.5.1 Using the RESET Button	41
Chapter 2	
Introducing the Web Configurator	43
2.1 Web Configurator Overview	43
2.2 Accessing the Web Configurator	43
2.3 Web Configurator Main Screen	45
2.3.1 Title Bar	46
2.3.2 Navigation Panel	46
2.3.3 Main Window	49
2.3.4 Status Bar	49
Chapter 3	
Status Screens	51

3.1 Overview	51
3.2 The Status Screen	51
3.3 Client List	54
3.4 Status: VPN Status	54
3.5 Any IP Table	54
3.6 Packet Statistics	55
Chapter 4	
Internet Setup Wizard	57
4.1 Overview	57
4.2 Internet Access Wizard Setup	57
4.2.1 Manual Configuration	60
Chapter 5	
Tutorials	67
5.1 Overview	67
5.2 Configuring Point-to-point Connection	67
5.2.1 Set Up the Server	68
5.2.2 Set Up the Client	69
5.2.3 Connect the P-793H v2s	69
5.3 Configuring a Point-to-2points Connection	70
5.3.1 Set up the Server	70
5.3.2 Set up the Clients	71
5.3.3 Connect the P-793H v2s	72
Part II: Technical Reference	73
Chapter 6	
WAN Setup.....	75
6.1 Overview	75
6.1.1 What You Can Do in the WAN Screens	75
6.1.2 What You Need to Know About WAN	76
6.1.3 Before You Begin	77
6.2 The Internet Access Setup Screen	78
6.2.1 2Wire-2Line Service Mode	82
6.2.2 Advanced Internet Access Setup	83
6.3 The More Connections Screen	86
6.3.1 More Connections Edit	87
6.3.2 Configuring More Connections Advanced Setup	90
6.4 The WAN Backup Setup Screen	92
6.5 WAN Technical Reference	93

6.5.1 Encapsulation	93
6.5.2 Multiplexing	95
6.5.3 VPI and VCI	95
6.5.4 IP Address Assignment	95
6.5.5 Nailed-Up Connection (PPP)	96
6.5.6 NAT	96
6.6 Metric	96
6.7 Traffic Redirect	97
6.8 Traffic Shaping	98
6.8.1 ATM Traffic Classes	99
Chapter 7	
LAN Setup.....	101
7.1 Overview	101
7.1.1 What You Can Do in the LAN Screens	101
7.1.2 What You Need To Know About LAN	102
7.1.3 Before You Begin	103
7.2 The IP Screen	103
7.2.1 The Advanced LAN IP Setup Screen	104
7.3 The DHCP Setup Screen	106
7.4 The Client List Screen	108
7.5 The IP Alias Screen	109
7.5.1 Configuring the LAN IP Alias Screen	110
7.6 LAN Technical Reference	111
7.6.1 LANs, WANs and the ZyXEL Device	111
7.6.2 DHCP Setup	112
7.6.3 DNS Server Addresses	112
7.6.4 LAN TCP/IP	113
7.6.5 RIP Setup	114
7.6.6 Multicast	114
Chapter 8	
Network Address Translation (NAT).....	117
8.1 Overview	117
8.1.1 What You Can Do in the NAT Screens	117
8.1.2 What You Need To Know About NAT	117
8.2 The NAT General Setup Screen	119
8.3 The Port Forwarding Screen	120
8.3.1 Configuring the Port Forwarding Screen	121
8.3.2 The Port Forwarding Rule Edit Screen	122
8.4 The Address Mapping Screen	123
8.4.1 The Address Mapping Rule Edit Screen	125
8.5 The ALG Screen	127

8.6 NAT Technical Reference	127
8.6.1 NAT Definitions	127
8.6.2 What NAT Does	128
8.6.3 How NAT Works	129
8.6.4 NAT Application	130
8.6.5 NAT Mapping Types	130
Chapter 9	
Firewalls.....	133
9.1 Overview	133
9.1.1 What You Can Do in the Firewall Screens	133
9.1.2 What You Need to Know About Firewall	134
9.1.3 Firewall Rule Setup Example	135
9.2 The Firewall General Screen	138
9.3 The Firewall Rule Screen	140
9.3.1 Configuring Firewall Rules	142
9.3.2 Customized Services	144
9.3.3 Configuring a Customized Service	145
9.4 The Firewall Threshold Screen	145
9.4.1 Threshold Values	146
9.4.2 Configuring Firewall Thresholds	147
9.5 Firewall Technical Reference	149
9.5.1 Firewall Rules Overview	149
9.5.2 Guidelines For Enhancing Security With Your Firewall	150
9.5.3 Security Considerations	151
9.5.4 Triangle Route	151
Chapter 10	
Content Filtering	155
10.1 Overview	155
10.1.1 What You Can Do in the Content Filter Screens	155
10.1.2 What You Need to Know About Content Filtering	155
10.1.3 Before You Begin	155
10.1.4 Content Filtering Example	156
10.2 The Keyword Screen	158
10.3 The Schedule Screen	159
10.4 The Trusted Screen	160
Chapter 11	
VPN.....	161
11.1 Overview	161
11.1.1 What You Can Do in the VPN Screens	161
11.1.2 What You Need to Know About IPSec VPN	162

11.1.3 Before You Begin	163
11.2 VPN Setup Screen	163
11.3 The VPN Edit Screen	166
11.4 Configuring Advanced IKE Settings	171
11.5 Manual Key Setup	173
11.5.1 Security Parameter Index (SPI)	174
11.6 Configuring Manual Key	174
11.7 Viewing SA Monitor	177
11.8 Configuring VPN Global Setting	179
11.9 IPSec VPN Technical Reference	179
11.9.1 IPSec Architecture	180
11.9.2 IPSec and NAT	180
11.9.3 VPN, NAT, and NAT Traversal	181
11.9.4 Encapsulation	183
11.9.5 IKE Phases	184
11.9.6 Negotiation Mode	185
11.9.7 Keep Alive	185
11.9.8 Remote DNS Server	185
11.9.9 ID Type and Content	186
11.9.10 Pre-Shared Key	188
11.9.11 Diffie-Hellman (DH) Key Groups	188
11.9.12 Telecommuter VPN/IPSec Examples	188
Chapter 12	
Certificates	193
12.1 Overview	193
12.1.1 What You Need to Know About Certificates	193
12.1.2 Verifying a Certificate	194
12.2 The Trusted CAs Screen	195
12.2.1 Trusted CA Import	197
12.2.2 Trusted CA Details	198
12.3 Certificates Technical Reference	200
12.3.1 Certificates Overview	200
12.3.2 Private-Public Certificates	200
Chapter 13	
Static Route	203
13.1 Overview	203
13.2 The Static Route Screen	204
13.2.1 Static Route Edit	205
Chapter 14	
802.1Q/1P	207

14.1 Overview	207
14.1.1 What You Can Do in the 802.1Q/1P Screens	207
14.1.2 What You Need to Know About 802.1Q/1P	207
14.1.3 802.1Q/1P Example	209
14.2 The 802.1Q/1P Group Setting Screen	213
14.2.1 Editing 802.1Q/1P Group Setting	214
14.3 The 802.1Q/1P Port Setting Screen	215
Chapter 15	
Quality of Service (QoS).....	217
15.1 Overview	217
15.2 QoS Overview	217
15.2.1 What You Can Do in the QoS Screens	218
15.2.2 What You Need to Know About QoS	218
15.2.3 QoS Class Setup Example	219
15.3 The QoS General Screen	223
15.4 The Class Setup Screen	224
15.4.1 The Class Configuration Screen	226
15.5 The QoS Monitor Screen	230
15.6 QoS Technical Reference	231
15.6.1 IEEE 802.1Q Tag	231
15.6.2 IP Precedence	231
15.6.3 DiffServ	232
15.6.4 Automatic Priority Queue Assignment	232
Chapter 16	
Dynamic DNS Setup	235
16.1 Overview	235
16.1.1 What You Need To Know About DDNS	235
16.2 The Dynamic DNS Screen	236
Chapter 17	
Remote Management.....	239
17.1 Overview	239
17.1.1 What You Can Do in the Remote Management Screens	240
17.1.2 What You Need to Know About Remote Management	240
17.2 The WWW Screen	241
17.2.1 Configuring the WWW Screen	241
17.3 The Telnet Screen	242
17.4 The FTP Screen	243
17.5 The SNMP Screen	244
17.5.1 Supported MIBs	246
17.5.2 SNMP Traps	246

17.5.3 Configuring SNMP	247
17.6 The DNS Screen	248
17.7 The ICMP Screen	249
Chapter 18	
Universal Plug-and-Play (UPnP).....	251
18.1 Overview	251
18.1.1 What You Can Do in the UPnP Screen	251
18.1.2 What You Need to Know About UPnP	251
18.2 The UPnP Screen	253
18.3 Installing UPnP in Windows Example	253
18.4 Using UPnP in Windows XP Example	257
Chapter 19	
System Settings.....	263
19.1 Overview	263
19.1.1 What You Can Do in the System Settings Screens	263
19.1.2 What You Need to Know About System Settings	263
19.2 The General Screen	264
19.3 The Time Setting Screen	266
Chapter 20	
Logs.....	269
20.1 Overview	269
20.1.1 What You Can Do in the Log Screens	269
20.1.2 What You Need To Know About Logs	269
20.2 The View Log Screen	270
20.3 The Log Settings Screen	271
20.4 SMTP Error Messages	273
20.4.1 Example E-mail Log	273
20.5 Log Descriptions	274
Chapter 21	
Tools.....	283
21.1 Overview	283
21.1.1 What You Can Do in the Tool Screens	283
21.1.2 What You Need To Know About Tools	284
21.1.3 Before You Begin	285
21.1.4 Tool Examples	285
21.2 The Firmware Screen	291
21.3 The Configuration Screen	293
21.4 The Restart Screen	295

Chapter 22	
Diagnostic.....	297
22.1 Overview	297
22.1.1 What You Can Do in the Diagnostic Screens	297
22.2 The General Diagnostic Screen	297
22.3 The DSL Line Diagnostic Screen	298
Chapter 23	
Introducing the SMT	301
23.1 Accessing the SMT	301
23.2 SMT Menu Items	302
23.3 Navigating the SMT Interface	305
Chapter 24	
General Setup.....	307
24.1 Configuring General Setup	307
24.1.1 Configuring Dynamic DNS	308
Chapter 25	
WAN Setup.....	311
25.1 WAN Setup	311
25.1.1 2wire-2line Service Mode	313
25.2 Configuring Traffic Redirect	315
Chapter 26	
LAN Setup.....	317
26.1 Accessing the LAN Menus	317
26.2 LAN Port Filter Setup	317
26.3 TCP/IP and DHCP Setup Menu	318
26.4 LAN IP Alias	320
Chapter 27	
Internet Access Setup	321
27.1 Internet Access Setup	321
Chapter 28	
Remote Node Setup.....	325
28.1 Introduction to Remote Node Setup	325
28.2 Remote Node Setup	325
28.3 Remote Node Profile	326
28.4 Remote Node Network Layer Options	328
28.5 Remote Node Filter	330
28.6 Remote Node ATM Layer Options	332

28.7 Advance Setup Options	333
Chapter 29	
Static Route Setup	335
29.1 IP Static Route Setup	335
29.2 Bridge Static Route Setup	337
Chapter 30	
NAT Setup.....	339
30.1 Using NAT	339
30.1.1 SUA (Single User Account) Versus NAT	339
30.1.2 Applying NAT	340
30.2 NAT Setup	341
30.2.1 Address Mapping Sets	342
30.3 Configuring a Server behind NAT	345
30.4 General NAT Examples	346
30.4.1 Internet Access Only	347
30.4.2 Example 2: Internet Access with a Default Server	348
30.4.3 Example 3: Multiple Public IP Addresses With Inside Servers	348
30.4.4 Example 4: NAT Unfriendly Application Programs	352
.....	353
Chapter 31	
Firewall Setup.....	355
31.1 Using P-793H v2 SMT Menus	355
31.1.1 Activating the Firewall	355
Chapter 32	
Filter Configuration.....	357
32.1 Introduction to Filters	357
32.1.1 The Filter Structure of the P-793H v2	358
32.2 Configuring a Filter Set	360
32.2.1 Configuring a Filter Rule	362
32.2.2 Configuring a TCP/IP Filter Rule	362
32.2.3 Configuring a Generic Filter Rule	366
32.3 Example Filter	367
32.4 Filter Types and NAT	369
32.5 Firewall Versus Filters	370
32.6 Applying a Filter	370
32.6.1 Applying LAN Filters	370
32.6.2 Applying Remote Node Filters	371
Chapter 33	
System Password	373

Chapter 34	
System Information & Diagnosis.....	375
34.1 Introduction to System Status	375
34.2 System Status	375
34.3 System Information and Console Port Speed	377
34.3.1 System Information	378
34.3.2 Console Port Speed	379
34.4 Log and Trace	379
34.4.1 Viewing Error Log	379
34.4.2 Syslog Logging	381
34.5 Diagnostic	384
Chapter 35	
Firmware and Configuration File Maintenance	387
35.1 Introduction	387
35.2 Filename Conventions	387
35.3 Backup Configuration	388
35.3.1 Backup Configuration	389
35.3.2 Using the FTP Command from the Command Line	389
35.3.3 Example of FTP Commands from the Command Line	390
35.3.4 GUI-based FTP Clients	390
35.3.5 File Maintenance Over WAN	390
35.3.6 Backup Configuration Using TFTP	391
35.3.7 TFTP Command Example	391
35.3.8 GUI-based TFTP Clients	392
35.3.9 Backup Via Console Port	392
35.4 Restore Configuration	393
35.4.1 Restore Using FTP	394
35.4.2 Restore Using FTP Session Example	395
35.4.3 Restore Via Console Port	395
35.5 Uploading Firmware and Configuration Files	396
35.5.1 Firmware File Upload	396
35.5.2 Configuration File Upload	397
35.5.3 FTP File Upload Command from the DOS Prompt Example	398
35.5.4 FTP Session Example of Firmware File Upload	398
35.5.5 TFTP File Upload	399
35.5.6 TFTP Upload Command Example	399
35.5.7 Uploading Via Console Port	400
35.5.8 Uploading Firmware File Via Console Port	400
35.5.9 Example Xmodem Firmware Upload Using HyperTerminal	401
35.5.10 Uploading Configuration File Via Console Port	401
35.5.11 Example Xmodem Configuration Upload Using HyperTerminal	402

Chapter 36	
Menus 24.8 to 24.11	403
36.1 Command Interpreter Mode	403
36.1.1 Command Syntax	403
36.1.2 Command Usage	404
36.2 Call Control Support	404
36.2.1 Budget Management	405
36.3 Time and Date Setting	406
36.4 Remote Management	409
36.4.1 Remote Management Limitations	409
Chapter 37	
Schedule Setup	411
37.1 Schedule Set Overview	411
37.2 Schedule Setup	411
37.3 Schedule Set Setup	412
Chapter 38	
Troubleshooting	415
38.1 Power, Hardware Connections, and LEDs	415
38.2 P-793H v2 Access and Login	416
38.3 Internet Access	418
38.4 Network Connections	419
Appendix A Product Specifications.....	421
Appendix B Wall-mounting Instructions.....	427
Appendix C Setting up Your Computer's IP Address	429
Appendix D Pop-up Windows, JavaScripts and Java Permissions.....	453
Appendix E IP Addresses and Subnetting	463
Appendix F Services	473
Appendix G Legal Information.....	477
Index.....	481

List of Figures

Figure 1 High-speed Internet Access with Your P-793H v2	38
Figure 2 Point-to-point Connections with Your P-793H v2	38
Figure 3 Point-to-2points Connections with Your P-793H v2	39
Figure 4 LEDs	40
Figure 5 Login Screen	44
Figure 6 Change Password at Login	44
Figure 7 Select a Mode	45
Figure 8 Main Screen	45
Figure 9 Status Screen	51
Figure 10 Any IP Table	54
Figure 11 Packet Statistics	55
Figure 12 Select a Mode	57
Figure 13 Wizard Welcome	58
Figure 14 Auto Detection: No DSL Connection	58
Figure 15 Auto-Detection: PPPoE	59
Figure 16 Auto Detection: Failed	59
Figure 17 Internet Access Wizard Setup: ISP Parameters	60
Figure 18 Internet Connection with PPPoE	61
Figure 19 Internet Connection with RFC 1483	62
Figure 20 Internet Connection with ENET ENCAP	63
Figure 21 Internet Connection with PPPoA	64
Figure 22 Internet Access Setup Complete	65
Figure 23 WAN > Internet Access Setup	68
Figure 24 WAN > Internet Access Setup	71
Figure 25 WAN > Internet Connection > Service Type of B	72
Figure 26 WAN > Internet Connection > Service Type of C	72
Figure 27 LAN and WAN	75
Figure 28 Network > WAN > Internet Access Setup	78
Figure 29 2wire-2line Service Mode	82
Figure 30 Network > WAN > Internet Access Setup: Advanced Setup	83
Figure 31 Network > WAN > More Connections	86
Figure 32 Network > WAN > More Connections: Edit	87
Figure 33 Network > WAN > More Connections: Edit: Advanced Setup	90
Figure 34 Network > Internet (WAN) > WAN Backup	92
Figure 35 Traffic Redirect Example	97
Figure 36 Traffic Redirect LAN Setup	98
Figure 37 Example of Traffic Shaping	99
Figure 38 Network > LAN > IP	103

Figure 39 Network > LAN > IP: Advanced Setup	104
Figure 40 Network > LAN > DHCP Setup	106
Figure 41 Network > LAN > Client List	108
Figure 42 Physical Network & Partitioned Logical Networks	109
Figure 43 Network > LAN > IP Alias	110
Figure 44 LAN and WAN IP Addresses	111
Figure 45 Network > NAT > General	119
Figure 46 Multiple Servers Behind NAT Example	121
Figure 47 Network > NAT > Port Forwarding	121
Figure 48 Network > NAT > Port Forwarding: Edit	122
Figure 49 Network > NAT > Address Mapping	124
Figure 50 Network > NAT > Address Mapping: Edit	125
Figure 51 Network > NAT > ALG	127
Figure 52 How NAT Works	129
Figure 53 NAT Application With IP Alias	130
Figure 54 Default Firewall Action	133
Figure 55 Security > Firewall > General	138
Figure 56 Security > Firewall > Rules	140
Figure 57 Security > Firewall > Rules: Edit	142
Figure 58 Security > Firewall > Rules: Edit: Edit Customized Services	144
Figure 59 Security > Firewall > Rules: Edit: Edit Customized Services: Config	145
Figure 60 Three-Way Handshake	146
Figure 61 Security > Firewall > Threshold	147
Figure 62 Ideal Firewall Setup	151
Figure 63 "Triangle Route" Problem	152
Figure 64 IP Alias	153
Figure 65 Security > Content Filtering > Keyword	158
Figure 66 Security > Content Filter > Schedule	159
Figure 67 Security > Content Filter: Trusted	160
Figure 68 VPN: Example	161
Figure 69 VPN: IKE SA and IPSec SA	162
Figure 70 IPSec Summary Fields	163
Figure 71 Security > VPN > Setup	164
Figure 72 Security > VPN > Setup > Edit	166
Figure 73 Security > VPN > Setup > Edit > Advanced Setup	171
Figure 74 Security > VPN > Setup > Manual Key	174
Figure 75 Security > VPN > Monitor	178
Figure 76 Security > VPN > Global Setting	179
Figure 77 IPSec Architecture	180
Figure 78 NAT Router Between IPSec Routers	182
Figure 79 Transport and Tunnel Mode IPSec Encapsulation	183
Figure 80 Two Phases to Set Up the IPSec SA	184
Figure 81 VPN Host using Intranet DNS Server Example	186

Figure 82 Telecommuters Sharing One VPN Rule Example	189
Figure 83 Telecommuters Using Unique VPN Rules Example	190
Figure 84 Certificates Example	193
Figure 85 Remote Host Certificates	194
Figure 86 Certificate Details	195
Figure 87 Trusted CAs	196
Figure 88 Trusted CA Import	197
Figure 89 Trusted CA Details	198
Figure 90 Example of Static Routing Topology	203
Figure 91 Advanced > Static Route	204
Figure 92 Advanced > Static Route: Edit	205
Figure 93 802.1Q/1P	207
Figure 94 Advanced > 802.1Q/1P > Group Setting	213
Figure 95 Advanced > 802.1Q/1P > Group Setting > Edit	214
Figure 96 Advanced > 802.1Q/1P > Port Setting	215
Figure 97 QoS Example	220
Figure 98 QoS Class Example: VoIP -1	220
Figure 99 QoS Class Example: VoIP -2	221
Figure 100 QoS Class Example: Boss -1	221
Figure 101 QoS Class Example: Boss -2	222
Figure 102 Advanced > QoS > General	223
Figure 103 Advanced > QoS > Class Setup	224
Figure 104 Advanced > QoS > Class Setup: Edit	226
Figure 105 Advanced > QoS > Monitor	230
Figure 106 Advanced > Dynamic DNS	236
Figure 107 Remote Management From the WAN	239
Figure 108 Advanced > Remote Management > WWW	241
Figure 109 Advanced > Remote Management > Telnet	242
Figure 110 Advanced > Remote Management > FTP	243
Figure 111 SNMP Management Model	245
Figure 112 Advanced > Remote Management > SNMP	247
Figure 113 Advanced > Remote Management > DNS	248
Figure 114 Advanced > Remote Management > ICMP	249
Figure 115 Advanced > UPnP > General	253
Figure 116 Maintenance > System > General	264
Figure 117 Maintenance > System > Time Setting	266
Figure 118 Maintenance > Logs > View Log	270
Figure 119 Maintenance > Logs > Log Settings	271
Figure 120 E-mail Log Example	274
Figure 121 Restore Using FTP Session Example	286
Figure 122 FTP Session Example of Firmware File Upload	287
Figure 123 FTP Session Example	289
Figure 124 Maintenance > Tools > Firmware	291

Figure 125 Firmware Upload In Progress	292
Figure 126 Network Temporarily Disconnected	292
Figure 127 Error Message	292
Figure 128 Maintenance > Tools > Configuration	293
Figure 129 Configuration Upload Successful	294
Figure 130 Network Temporarily Disconnected	294
Figure 131 Configuration Upload Error	294
Figure 132 Reset Warning Message	295
Figure 133 Reset In Process Message	295
Figure 134 Maintenance > Tools >Restart	295
Figure 135 Maintenance > Diagnostic > General	297
Figure 136 Maintenance > Diagnostic > DSL Line	298
Figure 137 Login Screen	301
Figure 138 SMT Main Menu	302
Figure 139 Menu 1: General Setup	307
Figure 140 Menu 1.1: Configure Dynamic DNS	309
Figure 141 Menu 2: WAN Setup	311
Figure 142 Menu 2: 2wire-2line Service Mode	313
Figure 143 Menu 2.1: Traffic Redirect Setup	315
Figure 144 Menu 3: LAN Setup	317
Figure 145 Menu 3.1: LAN Port Filter Setup	317
Figure 146 Menu 3.2: TCP/IP and DHCP Ethernet Setup	318
Figure 147 Menu 3.2.1: IP Alias Setup	320
Figure 148 Menu 4: Internet Access Setup	321
Figure 149 Menu 11: Remote Node Setup	325
Figure 150 Menu 11.1: Remote Node Profile (nodes 1-7)	326
Figure 151 Menu 11.3: Remote Node Network Layer Options	328
Figure 152 Menu 11.5: Remote Node Filter	331
Figure 153	Menu 11.6: Remote Node ATM Layer Options 332
Figure 154 Menu 11.8: Advance Setup Options	333
Figure 155 Menu 12.1: IP Static Route Setup	335
Figure 156 Menu 12.1.1: Edit IP Static Route	336
Figure 157 Menu 12.3: Bridge Static Route Setup	337
Figure 158 Menu 12.3.1: Edit Bridge Static Route	337
Figure 159 Menu 4: Applying NAT for Internet Access	340
Figure 160 Menu 11.3: Applying NAT to the Remote Node	341
Figure 161 Menu 15: NAT Setup	342
Figure 162 Menu 15.1: Address Mapping Sets	342
Figure 163 Menu 15.1.1: Address Mapping Rules	343
Figure 164 Menu 15.1.1.1: Address Mapping Rule	344
Figure 165 Menu 15.2: NAT Server Sets	345
Figure 166 Menu 15.2: NAT Server Setup	346
Figure 167 NAT Example 1	347

Figure 168 Menu 4: Internet Access & NAT Example	347
Figure 169 NAT Example 2	348
Figure 170 Menu 15.2: Specifying an Inside Server	348
Figure 171 NAT Example 3	349
Figure 172 Example 3: Menu 11.3	350
Figure 173 Example 3: Menu 15.1.1.1	351
Figure 174 Example 3: Final Menu 15.1.1	351
Figure 175 Example 3: Menu 15.2	352
Figure 176 NAT Example 4	352
Figure 177 Example 4: Menu 15.1.1.1: Address Mapping Rule	353
Figure 178 Menu 21: Filter and Firewall Setup	355
Figure 179 Menu 21.2: Firewall Setup	356
Figure 180 Outgoing Packet Filtering Process	357
Figure 181 Filter Rule Process	359
Figure 182 Menu 21: Filter and Firewall Setup	360
Figure 183 Menu 21.1: Filter Set Configuration	360
Figure 184 Menu 21.1.1: Filter Rules Summary	361
Figure 185 Menu 21.1.1.1: TCP/IP Filter Rule	363
Figure 186 Executing an IP Filter	365
Figure 187 Menu 21.1.1.1: Generic Filter Rule	366
Figure 188 Telnet Filter Example	367
Figure 189 Example Filter: Menu 21.1.3.1	368
Figure 190 Example Filter Rules Summary: Menu 21.1.3	369
Figure 191 Protocol and Device Filter Sets	370
Figure 192 Filtering LAN Traffic	371
Figure 193 Filtering Remote Node Traffic	371
Figure 194 Menu 23: System Password	373
Figure 195 Menu 24: System Maintenance	375
Figure 196 Menu 24.1: System Maintenance - Status	376
Figure 197 Menu 24.2: System Information and Console Port Speed	378
Figure 198 Menu 24.2.1: System Maintenance - Information	378
Figure 199 Menu 24.2.2: System Maintenance: Change Console Port Speed	379
Figure 200 Menu 24.3: System Maintenance - Log and Trace	380
Figure 201 Examples of Error and Information Messages	380
Figure 202 Menu 24.3.2: System Maintenance - UNIX Syslog	381
Figure 203 Menu 24.4: System Maintenance - Diagnostic	385
Figure 204 Menu 24.5: Backup Configuration	389
Figure 205 FTP Session Example	390
Figure 206 System Maintenance: Backup Configuration	392
Figure 207 System Maintenance: Starting Xmodem Download Screen	393
Figure 208 Backup Configuration Example	393
Figure 209 Successful Backup Confirmation Screen	393
Figure 210 Menu 24.6: Restore Configuration	394

Figure 211 Restore Using FTP Session Example	395
Figure 212 System Maintenance: Restore Configuration	395
Figure 213 System Maintenance: Starting Xmodem Download Screen	395
Figure 214 Restore Configuration Example	396
Figure 215 Successful Restoration Confirmation Screen	396
Figure 216 Menu 24.7.1: System Maintenance - Upload System Firmware	397
Figure 217 Menu 24.7.2: System Maintenance - Upload System Configuration File	397
Figure 218 FTP Session Example of Firmware File Upload	398
Figure 219 Menu 24.7.1 As Seen Using the Console Port	400
Figure 220 Example Xmodem Upload	401
Figure 221 Menu 24.7.2 As Seen Using the Console Port	401
Figure 222 Example Xmodem Upload	402
Figure 223 Command Mode in Menu 24	403
Figure 224 Valid Commands	404
Figure 225 Menu 24.9: System Maintenance - Call Control	405
Figure 226 Menu 24.9.1 - Budget Management	405
Figure 227 Menu 24: System Maintenance	406
Figure 228 Menu 24.10: System Maintenance - Time and Date Setting	407
Figure 229 Menu 24.11 – Remote Management Control	409
Figure 230 Menu 26: Schedule Setup	411
Figure 231 Menu 26.1: Schedule Set Setup	412
Figure 232 Y-Cable Configuration	426
Figure 233 Wall-mounting Example	427
Figure 234 WIndows 95/98/Me: Network: Configuration	430
Figure 235 Windows 95/98/Me: TCP/IP Properties: IP Address	431
Figure 236 Windows 95/98/Me: TCP/IP Properties: DNS Configuration	432
Figure 237 Windows XP: Start Menu	433
Figure 238 Windows XP: Control Panel	433
Figure 239 Windows XP: Control Panel: Network Connections: Properties	434
Figure 240 Windows XP: Local Area Connection Properties	434
Figure 241 Windows XP: Internet Protocol (TCP/IP) Properties	435
Figure 242 Windows XP: Advanced TCP/IP Properties	436
Figure 243 Windows XP: Internet Protocol (TCP/IP) Properties	437
Figure 244 Windows Vista: Start Menu	438
Figure 245 Windows Vista: Control Panel	438
Figure 246 Windows Vista: Network And Internet	438
Figure 247 Windows Vista: Network and Sharing Center	439
Figure 248 Windows Vista: Network and Sharing Center	439
Figure 249 Windows Vista: Local Area Connection Properties	440
Figure 250 Windows Vista: Internet Protocol Version 4 (TCP/IPv4) Properties	441
Figure 251 Windows Vista: Advanced TCP/IP Properties	442
Figure 252 Windows Vista: Internet Protocol Version 4 (TCP/IPv4) Properties	443
Figure 253 Macintosh OS 8/9: Apple Menu	444

Figure 254 Macintosh OS 8/9: TCP/IP	445
Figure 255 Macintosh OS X: Apple Menu	446
Figure 256 Macintosh OS X: Network	446
Figure 257 Red Hat 9.0: KDE: Network Configuration: Devices	447
Figure 258 Red Hat 9.0: KDE: Ethernet Device: General	448
Figure 259 Red Hat 9.0: KDE: Network Configuration: DNS	448
Figure 260 Red Hat 9.0: KDE: Network Configuration: Activate	449
Figure 261 Red Hat 9.0: Dynamic IP Address Setting in ifconfig-eth0	449
Figure 262 Red Hat 9.0: Static IP Address Setting in ifconfig-eth0	450
Figure 263 Red Hat 9.0: DNS Settings in resolv.conf	450
Figure 264 Red Hat 9.0: Restart Ethernet Card	450
Figure 265 Red Hat 9.0: Checking TCP/IP Properties	451
Figure 266 Pop-up Blocker	453
Figure 267 Internet Options: Privacy	454
Figure 268 Internet Options: Privacy	455
Figure 269 Pop-up Blocker Settings	456
Figure 270 Internet Options: Security	457
Figure 271 Security Settings - Java Scripting	458
Figure 272 Security Settings - Java	459
Figure 273 Java (Sun)	460
Figure 274 Mozilla Firefox: Tools > Options	460
Figure 275 Mozilla Firefox Content Security	461
Figure 276 Network Number and Host ID	464
Figure 277 Subnetting Example: Before Subnetting	467
Figure 278 Subnetting Example: After Subnetting	467

List of Tables

Table 1 LEDs	40
Table 2 Web Configurator Icons in the Title Bar	46
Table 3 Navigation Panel Summary	46
Table 4 Status Screen	52
Table 5 Any IP Table	54
Table 6 Packet Statistics	55
Table 7 Internet Access Wizard Setup: ISP Parameters	60
Table 8 Internet Connection with PPPoE	62
Table 9 Internet Connection with RFC 1483	63
Table 10 Internet Connection with ENET ENCAP	64
Table 11 Internet Connection with PPPoA	65
Table 12 Network > WAN > Internet Access Setup	79
Table 13 2wire-2line Service Mode	82
Table 14 Network > WAN > Internet Access Setup: Advanced Setup	83
Table 15 Network > WAN > More Connections	86
Table 16 Network > WAN > More Connections: Edit	87
Table 17 Network > WAN > More Connections: Edit: Advanced Setup	90
Table 18 Network > Internet (WAN) > WAN Backup	92
Table 19 Network > LAN > IP	104
Table 20 Network > LAN > IP: Advanced Setup	105
Table 21 Network > LAN > DHCP Setup	107
Table 22 Network > LAN > Client List	108
Table 23 Network > LAN > IP Alias	110
Table 24 Network > NAT > General	119
Table 25 Network > NAT > Port Forwarding	122
Table 26 Network > NAT > Port Forwarding: Edit	123
Table 27 Network > NAT > Address Mapping	124
Table 28 Network > NAT > Address Mapping: Edit	126
Table 29 Network > NAT > ALG	127
Table 30 NAT Definitions	128
Table 31 NAT Mapping Types	131
Table 32 Security > Firewall > General	139
Table 33 Security > Firewall > Rules	140
Table 34 Security > Firewall > Rules: Edit	142
Table 35 Security > Firewall > Rules: Edit: Edit Customized Services	144
Table 36 Security > Firewall > Rules: Edit: Edit Customized Services: Config	145
Table 37 Security > Firewall > Threshold	147
Table 38 Security > Content Filtering > Keyword	158

Table 39 Security > Content Filter: Schedule	159
Table 40 Security > Content Filter: Trusted	160
Table 41 Security > VPN > Setup	164
Table 42 Security > VPN > Setup > Edit	166
Table 43 Security > VPN > Setup > Edit > Advanced Setup	171
Table 44 Security > VPN > Setup > Manual Key	175
Table 45 Security > VPN > Monitor	178
Table 46 Security > VPN > Global Setting	179
Table 47 VPN and NAT	181
Table 48 VPN and NAT	182
Table 49 Local ID Type and Content Fields	187
Table 50 Peer ID Type and Content Fields	187
Table 51 Matching ID Type and Content Configuration Example	188
Table 52 Mismatching ID Type and Content Configuration Example	188
Table 53 Telecommuters Sharing One VPN Rule Example	189
Table 54 Telecommuters Using Unique VPN Rules Example	190
Table 55 Trusted CAs	196
Table 56 Trusted CA Import	197
Table 57 Trusted CA Details	198
Table 58 Advanced > Static Route	204
Table 59 Advanced > Static Route: Edit	205
Table 60 Advanced > 802.1Q/1P > Group Setting	213
Table 61 Advanced > 802.1Q/1P > Group Setting > Edit	214
Table 62 Advanced > 802.1Q/1P > Port Setting	216
Table 63 Advanced > QoS > General	223
Table 64 Advanced > QoS > Class Setup	224
Table 65 Advanced > QoS > Class Setup: Edit	227
Table 66 Advanced > QoS > Monitor	230
Table 67 IEEE 802.1p Priority Level and Traffic Type	231
Table 68 Internal Layer2 and Layer3 QoS Mapping	233
Table 69 Advanced > Dynamic DNS	236
Table 70 Advanced > Remote Management > WWW	242
Table 71 Advanced > Remote Management > Telnet	243
Table 72 Advanced > Remote Management > FTP	244
Table 73 SNMP Traps	246
Table 74 Advanced > Remote Management > SNMP	247
Table 75 Advanced > Remote Management > DNS	248
Table 76 Advanced > Remote Management > ICMP	249
Table 77 Advanced > UPnP > General	253
Table 78 Maintenance > System > General	265
Table 79 Maintenance > System > Time Setting	266
Table 80 Maintenance > Logs > View Log	270
Table 81 Maintenance > Logs > Log Settings	272

Table 82 SMTP Error Messages	273
Table 83 System Maintenance Logs	274
Table 84 System Error Logs	275
Table 85 Access Control Logs	276
Table 86 TCP Reset Logs	276
Table 87 Packet Filter Logs	277
Table 88 ICMP Logs	277
Table 89 CDR Logs	278
Table 90 PPP Logs	278
Table 91 UPnP Logs	278
Table 92 Content Filtering Logs	278
Table 93 Attack Logs	279
Table 94 802.1X Logs	279
Table 95 ACL Setting Notes	280
Table 96 ICMP Notes	280
Table 97 Syslog Logs	281
Table 98 RFC-2408 ISAKMP Payload Types	282
Table 99 Filename Conventions	284
Table 100 General Commands for GUI-based FTP Clients	289
Table 101 General Commands for GUI-based TFTP Clients	290
Table 102 Maintenance > Tools > Firmware	291
Table 103 Restore Configuration	293
Table 104 Maintenance > Diagnostic > General	298
Table 105 Maintenance > Diagnostic > DSL Line	299
Table 106 Main Menu Summary	302
Table 107 SMT Menus Overview	303
Table 108 Main Menu Commands	305
Table 109 Menu 1: General Setup	307
Table 110 Menu 1.1: Configure Dynamic DNS	309
Table 111 Menu 2: WAN Setup	312
Table 112 Menu 2: 2wire-2line Service Mode	314
Table 113 Menu 2.1: Traffic Redirect Setup	315
Table 114 Menu 3.2: TCP/IP and DHCP Ethernet Setup	318
Table 115 Menu 3.2.1: IP Alias Setup	320
Table 116 Menu 4: Internet Access Setup	321
Table 117 Menu 11.1: Remote Node Profile (nodes 1-7)	326
Table 118 Menu 11.3: Remote Node Network Layer Options	328
Table 119 Menu 11.5: Remote Node Filter	331
Table 120 Menu 11.6: Remote Node ATM Layer Options	332
Table 121 Menu 11.8: Advance Setup Options	333
Table 122 Menu 12.1.1: Edit IP Static Route	336
Table 123 Menu 12.3.1: Edit Bridge Static Route	337
Table 124 Applying NAT in Menus 4 & 11.3	341

Table 125 Menu 15.1.1: Address Mapping Rules	343
Table 126 Menu 15.1.1.1: Address Mapping Rule	344
Table 127 Menu 15.2: NAT Server Setup	346
Table 128 Abbreviations Used in the Filter Rules Summary Menu	361
Table 129 Rule Abbreviations Used	362
Table 130 Menu 21.1.1.1: TCP/IP Filter Rule	363
Table 131 Menu 21.1.1.1: Generic Filter Rule	366
Table 132 Menu 23: System Password	373
Table 133 Menu 24.1: System Maintenance - Status	376
Table 134 Menu 24.2.1: System Maintenance - Information	378
Table 135 Menu 24.3.2: System Maintenance - UNIX Syslog	381
Table 136 Menu 24.4: System Maintenance - Diagnostic	385
Table 137 Filename Conventions	388
Table 138 General Commands for GUI-based FTP Clients	390
Table 139 General Commands for GUI-based TFTP Clients	392
Table 140 Menu 24.9.1 - Budget Management	405
Table 141 Menu 24.10: System Maintenance - Time and Date Setting	407
Table 142 Menu 24.11 – Remote Management Control	409
Table 143 Menu 26: Schedule Setup	412
Table 144 Menu 26.1: Schedule Set Setup	413
Table 145 Device	421
Table 146 Firmware	422
Table 147 Firmware Features	425
Table 148 Subnet Masks	464
Table 149 Subnet Masks	465
Table 150 Maximum Host Numbers	465
Table 151 Alternative Subnet Mask Notation	466
Table 152 Subnet 1	468
Table 153 Subnet 2	468
Table 154 Subnet 3	469
Table 155 Subnet 4	469
Table 156 Eight Subnets	469
Table 157 24-bit Network Number Subnet Planning	470
Table 158 16-bit Network Number Subnet Planning	470
Table 159 Examples of Services	474

PART I

User's Guide

Getting To Know Your P-793H v2

This chapter introduces the main features and applications of your P-793H v2.

1.1 Overview

The P-793H v2 is a secure G.SHDSL.bis bonded broadband gateway that provides high-speed LAN-to-LAN connection and Internet access over the your telephone. It supports symmetrical multi-rate data transmission speed that adjusts the data rate automatically according to the quality of the wire connection.

You can set up your P-793H v2 for high-speed Internet access or for high-speed point-to-point or point-to-2 points connections with other SHDSL models. The P-793H v2 can be used for either IP routing or bridging depending on your network configuration. As a router, the P-793H v2 provides features such as firewall, content filtering and bandwidth management. As a bridge, the P-793H v2 minimizes the configuration changes you have to make in your existing network.

See [Appendix A on page 417](#) for a complete list of features you can configure on your P-793H v2.

1.1.1 High-speed Internet Access with G.SHDSL

The P-793H v2 provides high-speed G.SHDSL Internet access. The G.SHDSL (Single-pair High-speed Digital Subscriber Line) is a symmetrical, bi-directional DSL service that uses your telephone line to provide data rates up to 2.3 Mbits/sec. (The "G." in "G.SHDSL" is defined by the G.991.2 ITU (International

Telecommunication Union) state-of-the-art industry standard). Unlike ADSL or VDSL, G.SHDSL.bis supports the same high speed for transmission and receiving.

Figure 1 High-speed Internet Access with Your P-793H v2

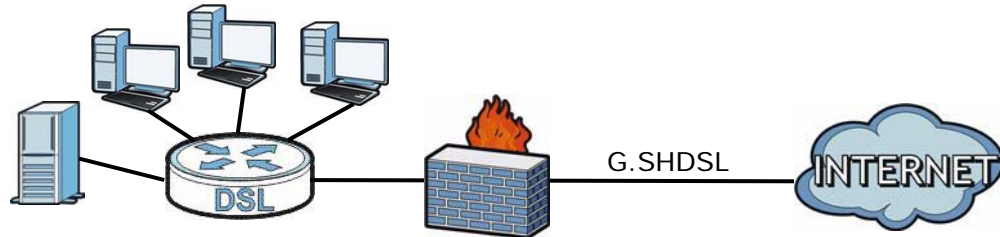

For Internet access, connect the DSL port to the phone port. Then, connect your computers or servers to the LAN ports for shared Internet access. (See the Quick Start Guide for detailed instructions about hardware connections.) Next, set up the P-793H v2 as a router or as a bridge, depending on the desired configuration.

1.1.2 High-speed Point-to-point Connections

You can use another P-793H v2 or any SHDSL device with the P-793H v2 to create a cost-effective, high-speed connection for high-bandwidth applications such as videoconferencing and distance learning.

Figure 2 Point-to-point Connections with Your P-793H v2

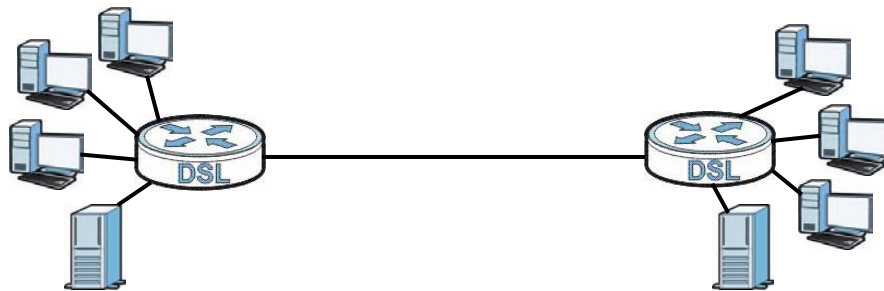

The P-793H v2s provide a simple, fast point-to-point connection between two geographically-dispersed networks.

1.1.3 High-speed Point-to-2points Connections

Use three P-793H v2s or 2 SHDSL devices with the P-793H v2 to connect two remote networks to a central location. For example, connect the headquarters to

two branch offices. In this scenario the central P-793H v2 acts in a similar way as an Internet service provider.

Figure 3 Point-to-2points Connections with Your P-793H v2

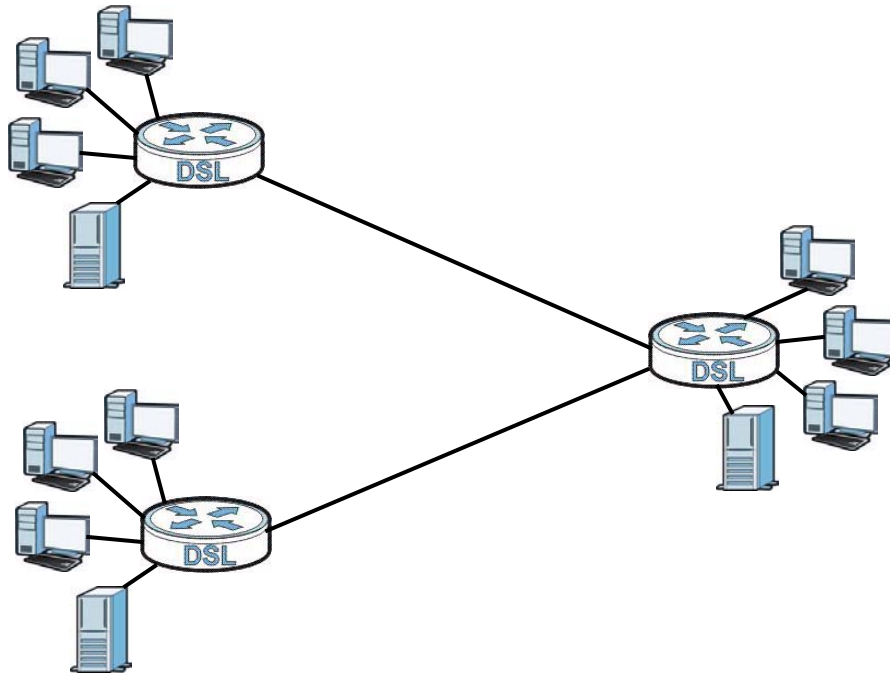

Note: See [Chapter 5 on page 67](#) for more information on setting up point-to-point and point-to-2points connections.

1.2 Ways to Manage the P-793H v2

Use any of the following methods to manage the P-793H v2.

- Web Configurator. This is recommended for everyday management of the P-793H v2 using a (supported) web browser. See [Chapter 2 on page 43](#).
- Command Line Interface. Line commands are mostly used for troubleshooting by service engineers. See [Appendix H on page 471](#).
- SMT. System Management Terminal is a text-based configuration menu that you can use to configure your device. See [Chapter 23 on page 301](#).
- FTP. Use File Transfer Protocol for firmware upgrades and configuration backup/restore. See [Chapter 17 on page 243](#).
- SNMP. The device can be monitored and/or managed by an SNMP manager. See [Chapter 17 on page 243](#).
- TR-069. This is a standard that defines how your P-793H v2 can be managed by a management server. See [Chapter 17 on page 243](#).

1.3 Good Habits for Managing the P-793H v2

Do the following things regularly to make the P-793H v2 more secure and to manage the P-793H v2 more effectively.

- Change the password. Use a password that's not easy to guess and that consists of different types of characters, such as numbers and letters.
- Write down the password and put it in a safe place.
- Back up the configuration (and make sure you know how to restore it). Restoring an earlier working configuration may be useful if the device becomes unstable or even crashes. If you forget your password, you will have to reset the P-793H v2 to its factory default settings. If you backed up an earlier configuration file, you would not have to totally re-configure the P-793H v2. You could simply restore your last configuration.

1.4 LEDs

The following figure shows the LEDs.

Figure 4 LEDs

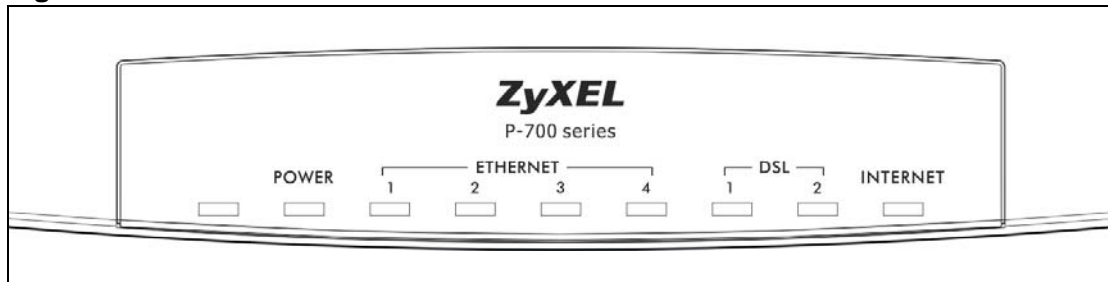

The following table describes the LEDs.

Table 1 LEDs

LED	COLOR	STATUS	DESCRIPTION
POWER	Green	On	The P-793H v2 is receiving power and functioning properly.
		Blinking	The P-793H v2 is rebooting or performing diagnostics.
	Red	On	Power to the P-793H v2 is too low.
		Off	The system is not ready or has malfunctioned.
LAN 1~4	Green	On	This port has a successful Ethernet connection.
		Blinking	This port is sending/receiving data.
		Off	This port is not connected.

Table 1 LEDs (continued)

LED	COLOR	STATUS	DESCRIPTION
DSL1/DSL2	Green	On	The DSL line is up.
		Blinking	The P-793H v2 is initializing the DSL line.
		Off	The DSL line is down.
<p>Note: For Internet access setup or point-to-point connections, the DSL1 and DSL2 LEDs indicate the status of a single connection (act as one LED). For point-to-2point connections, the DSL1 and DSL2 LEDs indicate the status of connection 1 and connection 2 respectively.</p>			
INTERNET	Green	On	The Internet connection is up, and the P-793H v2 has an IP address. (If the P-793H v2 uses RFC 1483 in bridge mode, this light does not turn on, but it does blink when the P-793H v2 is sending/receiving data.)
		Blinking	The P-793H v2 is sending/receiving data.
	Red	On	The P-793H v2 tried to get an IP address, but an error occurred.
		Off	The Internet connection is down.

1.5 The RESET Button

If you forget your password or cannot access the web configurator, you will need to use the **RESET** button at the back of the device to reload the factory-default configuration file. This means that you will lose all configurations that you had previously and the password will be reset to "1234".

1.5.1 Using the RESET Button

- 1 Make sure the **POWER** LED is on (not blinking).
- 2 To set the device back to the factory default settings, press the **RESET** button for ten seconds or until the **POWER** LED begins to blink and then release it. When the **POWER** LED begins to blink, the defaults have been restored and the device restarts.

Introducing the Web Configurator

2.1 Web Configurator Overview

The web configurator is an HTML-based management interface that allows easy P-793H v2 setup and management via Internet browser. Use Internet Explorer 6.0 and later or Netscape Navigator 7.0 and later versions. The recommended screen resolution is 1024 by 768 pixels.

In order to use the web configurator you need to allow:

- Web browser pop-up windows from your device. Web pop-up blocking is enabled by default in Windows XP SP (Service Pack) 2.
- JavaScripts (enabled by default).
- Java permissions (enabled by default).

See the chapter on troubleshooting if you need to make sure these functions are allowed in Internet Explorer.

2.2 Accessing the Web Configurator

- 1 Make sure your P-793H v2 hardware is properly connected (refer to the Quick Start Guide).
- 2 Launch your web browser.
- 3 Type "[192.168.1.1](#)" as the URL.

- 4 A password screen displays. The P-793H v2 has a dual login system. The default non-readable characters represents the user password (user by default). Clicking **Login without entering any password brings you to the system's status screen**. To access the administrative web configurator and manage the P-793H v2, type the admin password (1234 by default) in the password screen and click **Login**. Click **Cancel** to revert to the default user password in the password field. If you have changed the password, enter your password and click **Login**.

Figure 5 Login Screen



- 5 The following screen displays if you have not yet changed your password. It is strongly recommended you change the default password. Enter a new password, retype it to confirm and click **Apply**; alternatively click **Ignore** to proceed to the main menu if you do not want to change the password now.

Figure 6 Change Password at Login



- 6 Select **Go to Wizard setup** and click **Apply** to display the wizard main screen. Otherwise, select **Go to Advanced setup** and click **Apply** to display the **Status** screen.

Figure 7 Select a Mode



Note: For security reasons, the P-793H v2 automatically logs you out if you do not use the web configurator for five minutes (default). If this happens, log in again.

2.3 Web Configurator Main Screen

Figure 8 Main Screen

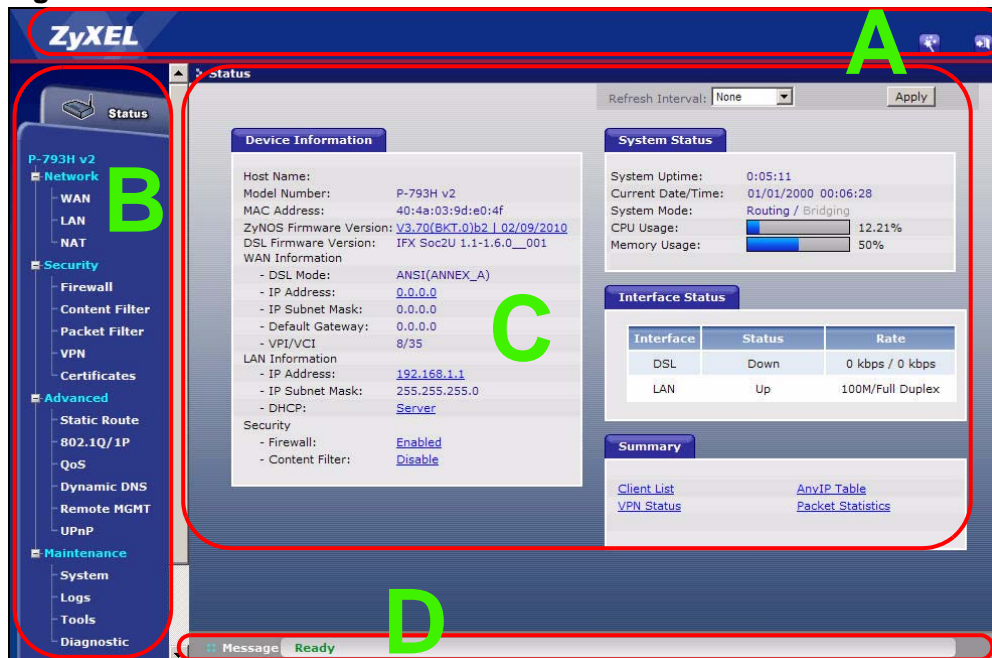

As illustrated above, the main screen is divided into these parts:

- **A** - title bar
- **B** - navigation panel
- **C** - main window
- **D** - status bar



2.3.1 Title Bar

The title bar provides some icons in the upper right corner.



The icons provide the following functions.

Table 2 Web Configurator Icons in the Title Bar

ICON	DESCRIPTION
	Wizards: Click this icon to go to the configuration wizards. See Chapter 5 on page 89 for more information.
	Logout: Click this icon to log out of the web configurator.

2.3.2 Navigation Panel

Use the menu items on the navigation panel to open screens to configure P-793H v2 features. The following tables describe each menu item.

Table 3 Navigation Panel Summary

LINK	TAB	FUNCTION
Status		This screen shows the P-793H v2's general device and network status information. Use this screen to access the statistics and client list.
Network		
WAN	Internet Access Setup	Use this screen to configure ISP parameters, WAN IP address assignment, DNS servers and point-to-point or point-to-point connections.
	More Connections	Use this screen to configure additional WAN connections.
	WAN Backup Setup	Use this screen to configure your traffic redirect properties and WAN backup settings.

Table 3 Navigation Panel Summary

LINK	TAB	FUNCTION
LAN	IP	Use this screen to configure LAN TCP/IP settings and other advanced properties.
	DHCP Setup	Use this screen to configure LAN DHCP settings.
	Client List	Use this screen to view current DHCP client information and to always assign specific IP addresses to individual MAC addresses (and host names).
	IP Alias	Use this screen to partition your LAN interface into subnets.
NAT	General	Use this screen to enable NAT.
	Port Forwarding	Use this screen to make your local servers visible to the outside world. This screen appears when you choose SUA Only from the NAT > General screen.
	Address Mapping	Use this screen to configure network address translation mapping rules. This screen appears when you choose Full Feature from the NAT > General screen.
	ALG	Use this screen to enable or disable SIP ALG.
Security		
Firewall	General	Use this screen to activate/deactivate the firewall and the default action to take on network traffic going in specific directions.
	Rules	This screen shows a summary of the firewall rules, and allows you to edit/add a firewall rule.
	Threshold	Use this screen to configure the thresholds for determining when to drop sessions that do not become fully established.
Content Filter	Keyword	Use this screen to block access to web sites containing certain keywords in the URL.
	Schedule	Use this screen to set the days and times for the P-793H v2 to perform content filtering.
	Trusted	Use this screen to exclude a range of users on the LAN from content filtering on your P-793H v2.
Packet Filter	Packet Filter	Use this screen to configure the rules for protocol and generic filter sets.
VPN	Setup	Use this screen to configure each VPN tunnel.
	Monitor	Use this screen to look at the current status of each VPN tunnel.
	VPN Global Setting	Use this screen to allow NetBIOS traffic through VPN tunnels.
Certificates	Trusted CAs	Use this screen to import CA certificates to the P-793H v2.
Advanced		

Table 3 Navigation Panel Summary

LINK	TAB	FUNCTION
Static Route	Static Route	Use this screen to configure IP static routes to tell your P-793H v2 about networks beyond the directly connected remote nodes.
802.1Q/1P	Group Setting	Use this screen to activate 802.1Q/1P, specify the management VLAN group, display the VLAN groups and configure the settings for each VLAN group.
	Port Setting	Use this screen to configure the PVID and assign traffic priority for each port.
QoS	General	Use this screen to enable QoS and traffic prioritizing, and configure bandwidth management on the WAN.
	Class Setup	Use this screen to define a classifier.
	Monitor	Use this screen to view each queue's statistics.
Dynamic DNS	Dynamic DNS	This screen allows you to use a static hostname alias for a dynamic IP address.
Remote MGMT	WWW	Use this screen to configure through which interface(s) and from which IP address(es) users can use HTTPS or HTTP to manage the P-793H v2.
	Telnet	Use this screen to configure through which interface(s) and from which IP address(es) users can use Telnet to manage the P-793H v2.
	FTP	Use this screen to configure through which interface(s) and from which IP address(es) users can use FTP to access the P-793H v2.
	SNMP	Use this screen to configure your P-793H v2's settings for Simple Network Management Protocol management.
	DNS	Use this screen to configure through which interface(s) and from which IP address(es) users can send DNS queries to the P-793H v2.
	ICMP	Use this screen to set whether or not your P-793H v2 will respond to pings and probes for services that you have not made available.
UPnP	General	Use this screen to turn UPnP on or off.
Maintenance		
System	General	Use this screen to configure your P-793H v2's name, domain name, management inactivity timeout and password.
	Time Setting	Use this screen to change your P-793H v2's time and date.
Logs	View Log	Use this screen to display your P-793H v2's logs.
	Log Settings	Use this screen to select which logs and/or immediate alerts your P-793H v2 is to record. You can also set it to e-mail the logs to you.

Table 3 Navigation Panel Summary

LINK	TAB	FUNCTION
Tools	Firmware	Use this screen to upload firmware to your P-793H v2.
	Configuration	Use this screen to backup and restore your P-793H v2's configuration (settings) or reset the factory default settings.
	Restart	This screen allows you to reboot the P-793H v2 without turning the power off.
Diagnostic	General	Use this screen to test the connections to other devices.
	DSL Line	These screen displays information to help you identify problems with the DSL connection.

2.3.3 Main Window

The main window displays information and configuration fields. It is discussed in the rest of this document.

Right after you log in, the **Status** screen is displayed. See [Chapter 3 on page 37](#) for more information about the **Status** screen.

2.3.4 Status Bar

Check the status bar when you click **Apply** or **OK** to verify that the configuration has been updated.

Status Screens

3.1 Overview

Use the **Status** screens to look at the current status of the device, system resources, and interfaces (LAN and WAN). The **Status** screen also provides detailed information of client list, Any IP, VPN and packet statistics.

3.2 The Status Screen

Use this screen to view the status of the P-793H v2. Click **Status** to open this screen.

Figure 9 Status Screen

The screenshot displays the Status screen for a P-793H v2 device. It features a 'Refresh Interval' dropdown set to 'None' and an 'Apply' button. The screen is divided into several sections:

- Device Information:**
 - Host Name:
 - Model Number: P-793H v2
 - MAC Address: 40:4a:03:9d:e0:4f
 - ZyNOS Firmware Version: [v3.70\(BKT_0\)b2 | 02/09/2010](#)
 - DSL Firmware Version: IFX Soc2U 1.1-1.6.0__001
 - WAN Information:**
 - DSL Mode: ANSI(ANNEX_A)
 - IP Address: [0.0.0.0](#)
 - IP Subnet Mask: 0.0.0.0
 - Default Gateway: 0.0.0.0
 - VPI/VCI: 8/35
 - LAN Information:**
 - IP Address: [192.168.1.1](#)
 - IP Subnet Mask: 255.255.255.0
 - DHCP: [Server](#)
 - Security:**
 - Firewall: [Enabled](#)
 - Content Filter: [Disable](#)
- System Status:**
 - System Uptime: 0:05:11
 - Current Date/Time: 01/01/2000 00:08:53
 - System Mode: Routing / Bridging
 - CPU Usage: 12.21%
 - Memory Usage: 50%
- Interface Status:**

Interface	Status	Rate
DSL	Down	0 kbps / 0 kbps
LAN	Up	100M/Full Duplex
- Summary:**
 - [Client List](#)
 - [VPN Status](#)
 - [AnyIP Table](#)
 - [Packet Statistics](#)

Each field is described in the following table.

Table 4 Status Screen

LABEL	DESCRIPTION
Refresh Interval	Select how often you want the P-793H v2 to update this screen.
Apply	Click this to update this screen immediately.
Device Information	
Host Name	This field displays the P-793H v2 system name. It is used for identification. You can change this in the Maintenance > System > General screen's System Name field.
Model Number	This is the model name of your device.
MAC Address	This is the MAC (Media Access Control) or Ethernet address unique to your P-793H v2.
ZyNOS Firmware Version	This is the current version of the firmware inside the device. It also shows the date the firmware version was created. Click this to go to the screen where you can change it.
DSL Firmware Version	This is the current version of the device's DSL modem code.
WAN Information	
DSL Mode	This is the DSL standard that your P-793H v2 is using.
IP Address	This is the current IP address of the P-793H v2 in the WAN. Click this to go to the screen where you can change it.
IP Subnet Mask	This is the current subnet mask in the WAN.
Default Gateway	This is the IP address of the default gateway, if applicable.
VPI/VCI	This is the Virtual Path Identifier and Virtual Channel Identifier that you entered in the wizard or WAN screen.
LAN Information	
IP Address	This is the current IP address of the P-793H v2 in the LAN. Click this to go to the screen where you can change it.
IP Subnet Mask	This is the current subnet mask in the LAN.
DHCP	This field displays what DHCP services the P-793H v2 is providing to the LAN. Choices are: Server - The P-793H v2 is a DHCP server in the LAN. It assigns IP addresses to other computers in the LAN. Relay - The P-793H v2 acts as a surrogate DHCP server and relays DHCP requests and responses between the remote server and the clients. None - The P-793H v2 is not providing any DHCP services to the LAN. Click this to go to the screen where you can change it.
Security	
Firewall	This displays whether or not the P-793H v2's firewall is activated. Click this to go to the screen where you can change it.

Table 4 Status Screen

LABEL	DESCRIPTION
Content Filter	This displays whether or not the P-793H v2's content filtering is activated. Click this to go to the screen where you can change it.
System Status	
System Uptime	This field displays how long the P-793H v2 has been running since it last started up. The P-793H v2 starts up when you plug it in, when you restart it (Maintenance > Tools > Restart), or when you reset it.
Current Date/Time	This field displays the current date and time in the P-793H v2. You can change this in Maintenance > System > Time Setting .
System Mode	This displays whether the P-793H v2 is functioning as a router or a bridge.
CPU Usage	This field displays what percentage of the P-793H v2's processing ability is currently used. When this percentage is close to 100%, the P-793H v2 is running at full load, and the throughput is not going to improve anymore. If you want some applications to have more throughput, you should turn off other applications (for example, using QoS; see Chapter 15 on page 217).
Memory Usage	This field displays what percentage of the P-793H v2's memory is currently used. Usually, this percentage should not increase much. If memory usage does get close to 100%, the P-793H v2 is probably becoming unstable, and you should restart the device. See Section 21.4 on page 295 , or turn off the device (unplug the power) for a few seconds.
Interface Status	
Interface	This column displays each interface the P-793H v2 has.
Status	This field indicates whether or not the P-793H v2 is using the interface. For the DSL interface, this field displays Down (line is down), Up (line is up or connected) if you're using Ethernet encapsulation and Down (line is down), Up (line is up or connected), Idle (line (ppp) idle), Dial (starting to trigger a call) and Drop (dropping a call) if you're using PPPoE encapsulation. For the LAN interface, this field displays Up when the P-793H v2 is using the interface and Down when the P-793H v2 is not using the interface.
Rate	For the LAN interface, this displays the port speed and duplex setting. For the DSL interface, it displays the downstream and upstream transmission rate.
Summary	
Client List	Click this link to view current DHCP client information. See Section 7.4 on page 108 .
VPN Status	Click this link to view the status of any VPN tunnels the P-793H v2 has negotiated. See Section 3.4 on page 54 .
AnyIP Table	Click this link to view a list of IP addresses and MAC addresses of computers, which are not in the same subnet as the P-793H v2. See Section 3.5 on page 54 .
Packet Statistics	Click this link to view port status and packet specific statistics. See Section 3.6 on page 55 .

3.3 Client List

See [Section 7.4 on page 108](#) for information on this screen.

3.4 Status: VPN Status

See [Section Figure 75 on page 178](#) for information on this screen.

3.5 Any IP Table

Click **Status > AnyIP Table** to access this screen. Use this screen to view the IP address and MAC address of each computer that is using the P-793H v2 but is in a different subnet than the P-793H v2.

Figure 10 Any IP Table



Each field is described in the following table.

Table 5 Any IP Table

LABEL	DESCRIPTION
#	This field is a sequential value. It is not associated with a specific entry.
IP Address	This field displays the IP address of each computer that is using the P-793H v2 but is in a different subnet than the P-793H v2.
MAC Address	This field displays the MAC address of the computer that is using the P-793H v2 but is in a different subnet than the P-793H v2.
Refresh	Click this to update this screen.

3.6 Packet Statistics

Read-only information here includes port status and packet specific statistics. Also provided are "system up time" and "poll interval(s)". The **Poll Interval(s)** field is configurable. Click **Status > Packet Statistics** to access this screen.

Figure 11 Packet Statistics

System Monitor								
System up Time:	29:01:45							
Current Date/Time:	01/02/2000 05:01:37							
CPU Usage:	6.59%							
Memory Usage:	49%							
WAN Port Statistics								
Link Status:	Down							
WAN IP Address:	0.0.0.0							
Upstream Speed:	0 kbps							
Downstream Speed:	0 kbps							
Node-Link	Status	TxPkts	RxPkts	Errors	Tx B/s	Rx B/s	Up Time	
1-ENET	N/A	0	0	0	0	0	0:00:00	
2	N/A	0	0	0	0	0	0:00:00	
3	N/A	0	0	0	0	0	0:00:00	
4	N/A	0	0	0	0	0	0:00:00	
5	N/A	0	0	0	0	0	0:00:00	
6	N/A	0	0	0	0	0	0:00:00	
7	N/A	0	0	0	0	0	0:00:00	
8	N/A	0	0	0	0	0	0:00:00	
LAN Port Statistics								
Interface	Status	TxPkts	RxPkts	Collisions				
Ethernet	100M/Full Duplex	13126	8186	0				
Poll Interval(s) : <input type="text" value="5"/> sec <input type="button" value="Set Interval"/> <input type="button" value="Stop"/>								

The following table describes the fields in this screen.

Table 6 Packet Statistics

LABEL	DESCRIPTION
System Monitor	
System up Time	This is the elapsed time the system has been up.
Current Date/Time	This field displays your P-793H v2's present date and time.
CPU Usage	This field specifies the percentage of CPU utilization.
Memory Usage	This field specifies the percentage of memory utilization.
WAN Port Statistics	
Link Status	This is the status of your WAN link.
WAN IP Address	This is the IP address of the P-793H v2's WAN port.
Upstream Speed	This is the upstream speed of your P-793H v2.
Downstream Speed	This is the downstream speed of your P-793H v2.

Table 6 Packet Statistics (continued)

LABEL	DESCRIPTION
Node-Link	This field displays the remote node index number and link type. Link types are PPPoA, ENET, RFC 1483 and PPPoE.
Status	This field displays Down (line is down), Up (line is up or connected) if you're using Ethernet encapsulation and Down (line is down), Up (line is up or connected), Idle (line (ppp) idle), Dial (starting to trigger a call) and Drop (dropping a call) if you're using PPPoE encapsulation.
TxPkts	This field displays the number of packets transmitted on this port.
RxPkts	This field displays the number of packets received on this port.
Errors	This field displays the number of error packets on this port.
Tx B/s	This field displays the number of bytes transmitted in the last second.
Rx B/s	This field displays the number of bytes received in the last second.
Up Time	This field displays the elapsed time this port has been up.
LAN Port Statistics	
Interface	This field displays Ethernet (LAN ports).
Status	For the LAN ports, this field displays Down (line is down) or Up (line is up or connected).
TxPkts	This field displays the number of packets transmitted on this interface.
RxPkts	This field displays the number of packets received on this interface.
Collisions	This is the number of collisions on this interfaces.
Poll Interval(s)	Type the time interval for the browser to refresh system statistics.
Set Interval	Click this to apply the new poll interval you entered in the Poll Interval field above.
Stop	Click this to halt the refreshing of the system statistics.

Internet Setup Wizard

4.1 Overview

Use the wizard setup screens to configure your system for Internet access with the information given to you by your ISP.

Note: See the advanced menu chapters for background information on these fields.

4.2 Internet Access Wizard Setup

- 1 After you enter the password to access the web configurator, select **Go to Wizard setup** and click **Apply**. Otherwise, click the wizard icon () in the top right corner of the web configurator to go to the wizards.

Figure 12 Select a Mode



- 2 Click **INTERNET SETUP** to configure the system for Internet access.

Figure 13 Wizard Welcome

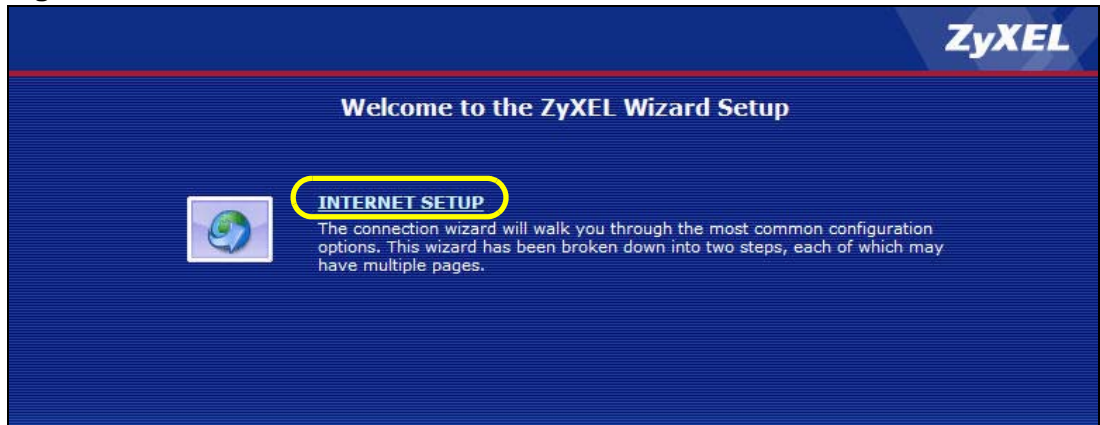

- 3 Your P-793H v2 attempts to detect your DSL connection and your connection type.
 - 3a The following screen appears if a connection is not detected. Check your hardware connections and click **Restart the INTERNET SETUP Wizard** to return to the wizard welcome screen. If you still cannot connect, click **Manually configure your Internet connection**. Follow the directions in the wizard and enter your Internet setup information as provided to you by your ISP. See [Section 4.2.1 on page 60](#) for more details.

Figure 14 Auto Detection: No DSL Connection

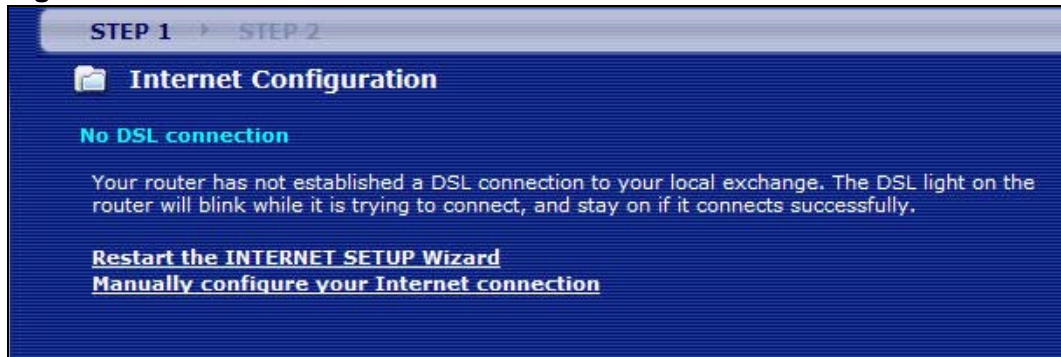

- 3b The following screen displays if a PPPoE or PPPoA connection is detected. Enter your Internet account information (username, password and/or service name) exactly as provided by your ISP. Then click **Next**.

Figure 15 Auto-Detection: PPPoE

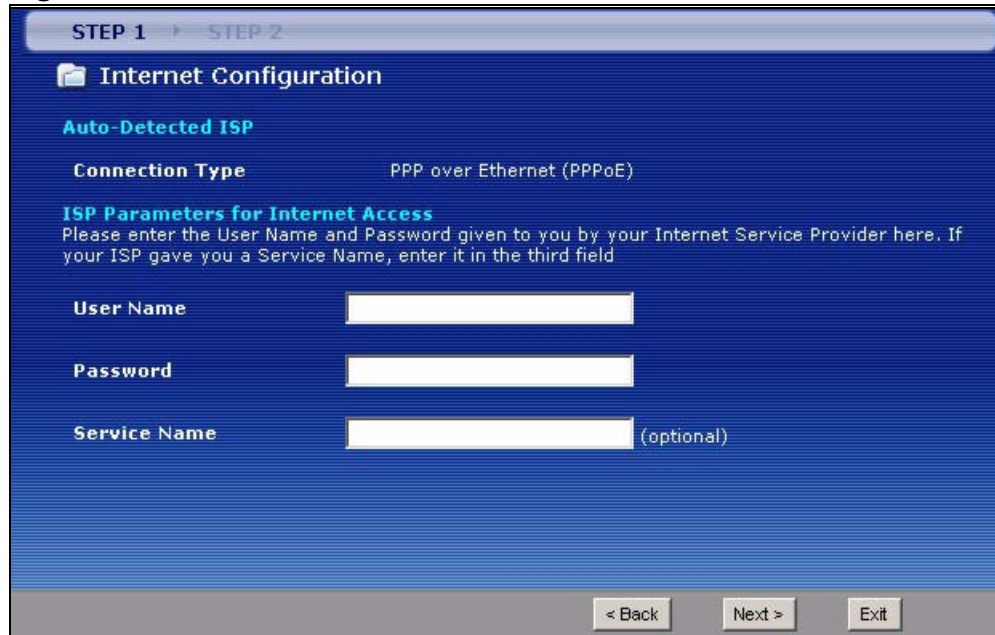

The screenshot shows a web-based configuration wizard titled "Internet Configuration". At the top, it indicates "STEP 1" and "STEP 2". Below the title, there is a section for "Auto-Detected ISP". Under this section, the "Connection Type" is listed as "PPP over Ethernet (PPPoE)". Below this, there is a heading "ISP Parameters for Internet Access" followed by a note: "Please enter the User Name and Password given to you by your Internet Service Provider here. If your ISP gave you a Service Name, enter it in the third field". There are three input fields: "User Name", "Password", and "Service Name (optional)". At the bottom of the screen, there are three buttons: "< Back", "Next >", and "Exit".

- 3c The following screen appears if the ZyXEL device detects a connection but not the connection type. Click **Next** and refer to [Section 4.2.1 on page 60](#) on how to manually configure the P-793H v2 for Internet access.

Figure 16 Auto Detection: Failed

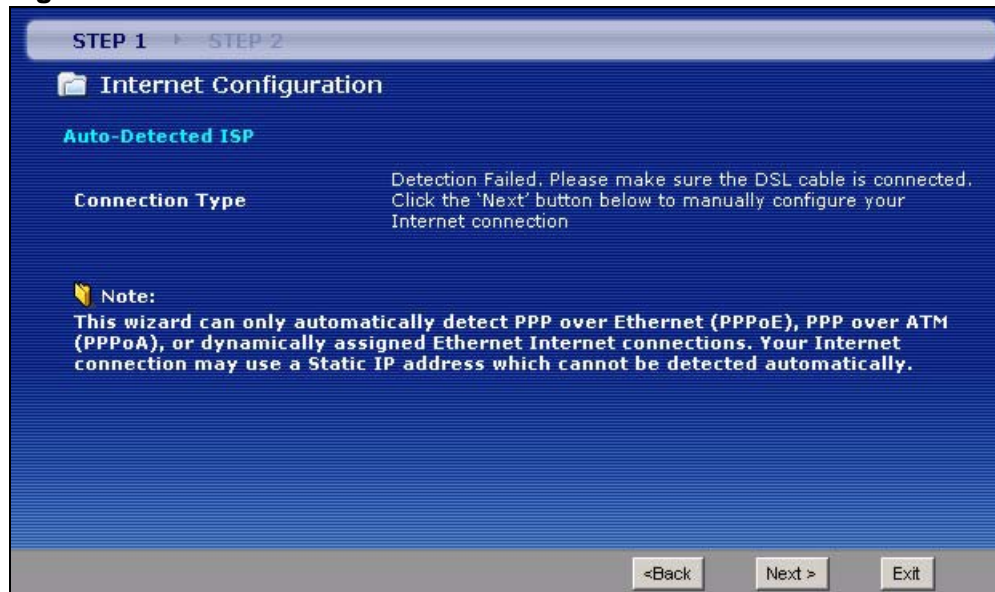

The screenshot shows the same "Internet Configuration" wizard. The "Auto-Detected ISP" section now displays "Connection Type" as "Detection Failed. Please make sure the DSL cable is connected. Click the 'Next' button below to manually configure your Internet connection". Below this, there is a "Note" icon followed by the text: "This wizard can only automatically detect PPP over Ethernet (PPPoE), PPP over ATM (PPPoA), or dynamically assigned Ethernet Internet connections. Your Internet connection may use a Static IP address which cannot be detected automatically." At the bottom, the "< Back", "Next >", and "Exit" buttons are visible.

4.2.1 Manual Configuration

- 1 If the P-793H v2 fails to detect your DSL connection type but the physical line is connected, enter your Internet access information in the wizard screen exactly as your service provider gave it to you. Leave the defaults in any fields for which you were not given information.

Figure 17 Internet Access Wizard Setup: ISP Parameters

The following table describes the fields in this screen.

Table 7 Internet Access Wizard Setup: ISP Parameters

LABEL	DESCRIPTION
Mode	Select Routing (default) from the drop-down list box if your ISP give you one IP address only and you want multiple computers to share an Internet account. Select Bridge when your ISP provides you more than one IP address and you want the connected computers to get individual IP address from ISP's DHCP server directly. If you select Bridge , you cannot use Firewall, DHCP server and NAT on the P-793H v2.
Encapsulation	Select the encapsulation type your ISP uses from the Encapsulation drop-down list box. Choices vary depending on what you select in the Mode field. If you select Bridge in the Mode field, select either PPPoA or RFC 1483 . If you select Routing in the Mode field, select PPPoA , RFC 1483 , ENET ENCAP or PPPoE .

Table 7 Internet Access Wizard Setup: ISP Parameters

LABEL	DESCRIPTION
Multiplexing	Select the multiplexing method used by your ISP from the Multiplex drop-down list box either VC-based or LLC-based.
Virtual Circuit ID	VPI (Virtual Path Identifier) and VCI (Virtual Channel Identifier) define a virtual circuit. Refer to the appendix for more information.
VPI	Enter the VPI assigned to you. This field may already be configured.
VCI	Enter the VCI assigned to you. This field may already be configured.
Back	Click this to return to the previous screen without saving.
Next	Click this to continue to the next wizard screen. The next wizard screen you see depends on what protocol you chose above.
Exit	Click this to close the wizard screen without saving.

- 2 The next wizard screen varies depending on what mode and encapsulation type you use. All screens shown are with routing mode. Configure the fields and click **Next** to continue.

Figure 18 Internet Connection with PPPoE

STEP 1 → STEP 2

Internet Configuration

ISP Parameters for Internet Access
Please enter the User Name and Password given to you by your Internet Service Provider here. If your ISP gave you a Service Name, enter it in the third field

User Name

Password

Service Name (optional)

Note:
Device is automatically configured to obtain an IP address automatically. The ISP will assign you a different one each time you connect to the Internet.

< Back Apply Exit

The following table describes the fields in this screen.

Table 8 Internet Connection with PPPoE

LABEL	DESCRIPTION
User Name	Enter the user name exactly as your ISP assigned. If assigned a name in the form user@domain where domain identifies a service name, then enter both components exactly as given.
Password	Enter the password associated with the user name above.
Service Name	Type the name of your PPPoE service here.
Back	Click this to return to the previous screen without saving.
Apply	Click this to save your changes.
Exit	Click this to close the wizard screen without saving.

Figure 19 Internet Connection with RFC 1483

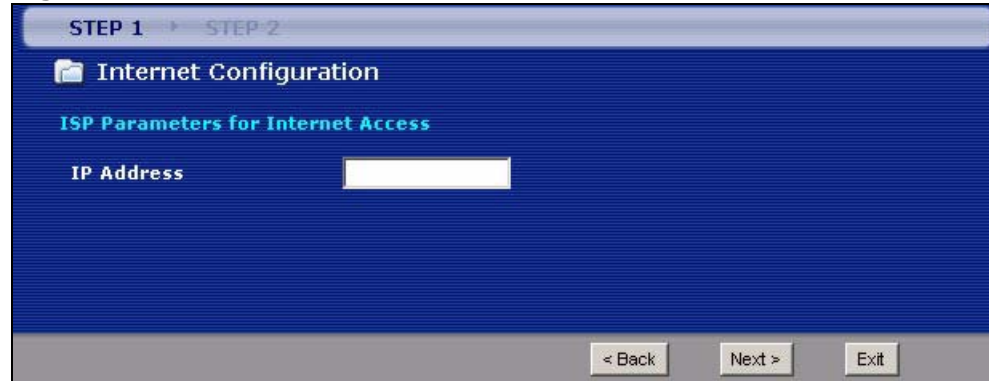

The screenshot shows a wizard window with a blue background. At the top, there is a progress bar with 'STEP 1' selected and 'STEP 2' next to it. Below the progress bar, the title 'Internet Configuration' is displayed. Underneath, the text 'ISP Parameters for Internet Access' is shown in a lighter blue color. A label 'IP Address' is positioned to the left of a white text input field. At the bottom of the window, there are three buttons: '< Back', 'Next >', and 'Exit'.

The following table describes the fields in this screen.

Table 9 Internet Connection with RFC 1483

LABEL	DESCRIPTION
IP Address	This field is available if you select Routing in the Mode field. Type your ISP assigned IP address in this field.
Back	Click this to return to the previous screen without saving.
Next	Click this to continue to the next wizard screen.
Exit	Click this to close the wizard screen without saving.

Figure 20 Internet Connection with ENET ENCAP

STEP 1 ▶ STEP 2

Internet Configuration

ISP Parameters for Internet Access

Select 'Obtain an IP Address Automatically' if your ISP assigns you a dynamic IP address (DHCP); otherwise select 'Static IP Address' and type the static IP information your ISP gave you.

Obtain an IP Address Automatically
 Static IP Address

IP Address: 0.0.0.0
 Subnet Mask: 0.0.0.0
 Gateway IP address: 0.0.0.0
 First DNS Server: 0.0.0.0
 Second DNS Server: 0.0.0.0

<Back Apply Exit

The following table describes the fields in this screen.

Table 10 Internet Connection with ENET ENCAP

LABEL	DESCRIPTION
Obtain an IP Address Automatically	A static IP address is a fixed IP that your ISP gives you. A dynamic IP address is not fixed; the ISP assigns you a different one each time you connect to the Internet. Select Obtain an IP Address Automatically if you have a dynamic IP address.
Static IP Address	Select Static IP Address if your ISP gave you an IP address to use.
IP Address	Enter your ISP assigned IP address.
Subnet Mask	Enter a subnet mask in dotted decimal notation. Refer to the appendix to calculate a subnet mask If you are implementing subnetting.
Gateway IP address	You must specify a gateway IP address (supplied by your ISP) when you use ENET ENCAP in the Encapsulation field in the previous screen.
First DNS Server	Enter the IP addresses of the DNS servers. The DNS servers are passed to the DHCP clients along with the IP address and the subnet mask.
Second DNS Server	As above.
Back	Click this to return to the previous screen without saving.
Apply	Click this to save your changes.
Exit	Click this to close the wizard screen without saving.

Figure 21 Internet Connection with PPPoA

The screenshot shows a blue-themed wizard window titled "Internet Configuration". At the top, it indicates "STEP 1" and "STEP 2". Below the title, there is a folder icon and the text "Internet Configuration". Underneath, it says "ISP Parameters for Internet Access" and "Please enter the User Name and Password given to you by your Internet Service Provider here". There are two input fields: "User Name" and "Password". A yellow note icon is followed by the text: "Note: Device is automatically configured to obtain an IP address automatically. The ISP will assigns you a different one each time you connect to the Internet." At the bottom of the window, there are three buttons: "< Back", "Apply", and "Exit".

The following table describes the fields in this screen.

Table 11 Internet Connection with PPPoA

LABEL	DESCRIPTION
User Name	Enter the login name that your ISP gives you.
Password	Enter the password associated with the user name above.
Back	Click this to return to the previous screen without saving.
Apply	Click this to save your changes.
Exit	Click this to close the wizard screen without saving.

- Use the read-only summary table to check whether what you have configured is correct. Click **Finish** to complete and save the wizard setup.

Figure 22 Internet Access Setup Complete

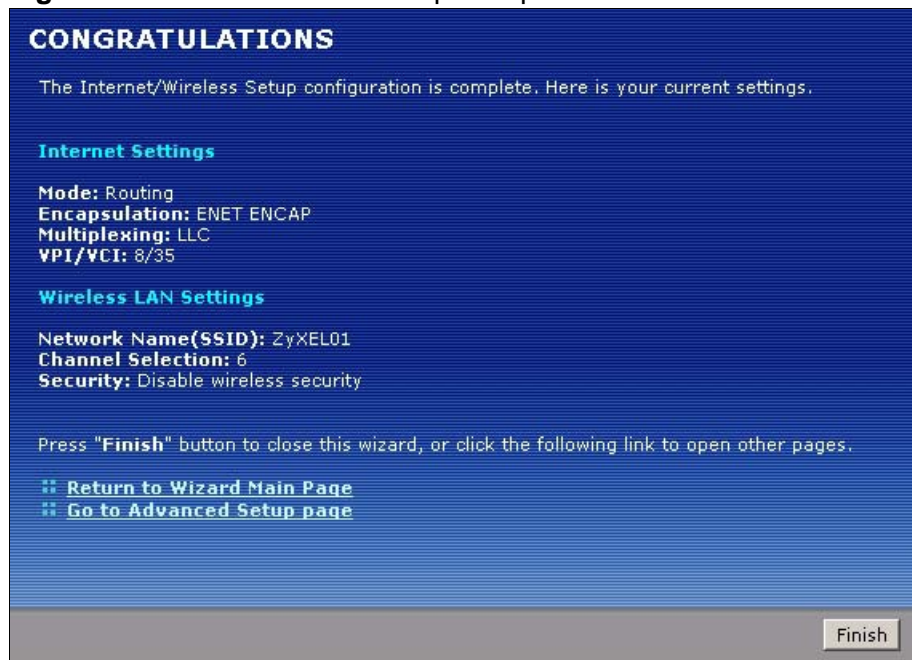

- Launch your web browser and navigate to www.zyxel.com. Internet access is just the beginning. Refer to the rest of this guide for more detailed information on the complete range of P-793H v2 features. If you cannot access the Internet, open the web configurator again to confirm that the Internet settings you configured in the wizard setup are correct.

5.1 Overview

This chapter describes:

- [Configuring Point-to-point Connection](#), see [page 67](#)
- [Configuring a Point-to-2points Connection](#), see [page 70](#)

Note: The tutorials featured in this chapter require a basic understanding of connecting to and using the Web Configurator on your P-793H v2. For details, see the included Quick Start Guide. For field descriptions of individual screens, see the related technical reference in this User's Guide.

5.2 Configuring Point-to-point Connection

In this scenario, Company **A** wants to set up a point-to-point connection with its branch office **B** by using two P-793H v2s. The two P-793H v2s are directly connected together through their DSL ports. The P-793H v2 on **A**'s side is the server and the P-793H v2 on **B**'s side is the client. The maximum transfer rate for the DSL connection between **A** and **B** is **5696** Kbps and the minimum transfer rate is **3200** Kbps.

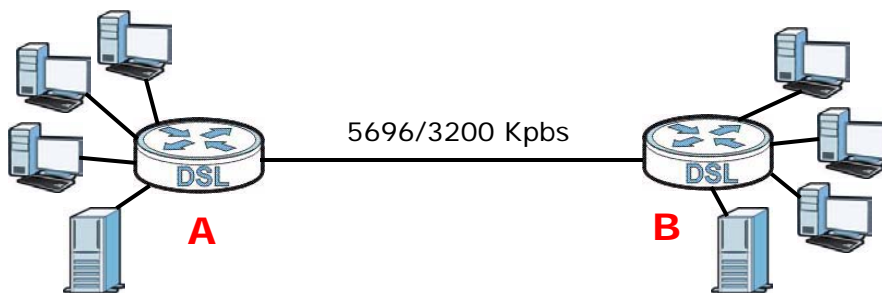

To set up the point-to-point connection between **A** and **B**, you need to:

- 1 [Set Up the Server.](#)

- 2 Set Up the Client.
- 3 Connect the P-793H v2s.

5.2.1 Set Up the Server

- 1 Log in to the server P-793H v2 of Company A.
- 2 Click **Network > WAN > Internet Access Setup**.
- 3 Configure the **Internet Access Setup** screen as the following. Select **ATM** as the **Transfer Mode**. Select **Bridge** as the **Mode**. Configure the **Multiplexing**, **Encapsulation**, **VPI**, and **VCI** fields for the point-to-point connection. Select **1** in the **Line** field as the DSL line you want the P-793H v2 to use as a default for outgoing traffic.
- 4 Then configure the **Service Type** section. Select **2 wire** in the **Service Mode** field. In the **Service Type** field, select **Server**. Select **5696** as the **Transfer Max Rate** and **3200** as the **Transfer Min Rate**. Leave the rest of the fields set to their default settings. Click **Apply**.

Figure 23 WAN > Internet Access Setup

The screenshot displays the 'Internet Access Setup' configuration window. It is divided into three main sections: General, DNS server, and Service Type. The 'General' section contains fields for Transfer Mode (ATM), Mode (Bridge), Encapsulation (RFC 1483), Multiplexing (LLC), Virtual Circuit ID (8), VPI (35), VCI (1), and Line (1). The 'DNS server' section has three fields for First, Second, and Third DNS Servers, each with a dropdown set to 'UserDefined' and a text box containing '0.0.0.0'. The 'Service Type' section includes Service Mode (2 wire), Service Type (Server), Enable Rate Adaption (Enable), Transfer Max Rate (5696), Transfer Min Rate (3200), Standard Mode (ANSI(ANNEX_A)), and Modulation (PAM32). At the bottom, there are three buttons: 'Apply', 'Cancel', and 'Advanced Setup'.

5.2.2 Set Up the Client

- 1 Log in to the client P-793H v2 of branch office **B**.
- 2 Click **Network > WAN > Internet Access Setup**.
- 3 Select **ATM** as the **Transfer Mode**. Select **Bridge** as the **Mode**. Set the **Multiplexing**, **Encapsulation**, **VPI**, and **VCI** to the same values you set in the server. Select **1** in the **Line** field as the DSL line you want the P-793H v2 to use as a default for outgoing traffic.
- 4 Scroll down to the **Service Type** section. In the **Service Mode** field, select **2 wire**, the same type of connection you selected for the server. In the **Service Type** field, select **Client**. The rest of the fields will be negotiated with the server. Click **Apply**.

The screenshot shows the 'Internet Access Setup' configuration window. It has three tabs: 'Internet Access Setup' (selected), 'More Connections', and 'WAN Backup Setup'. The window is divided into three main sections: 'General', 'DNS server', and 'Service Type'.
 In the 'General' section, the following fields are highlighted with a red circle:
 - Transfer Mode: ATM
 - Mode: Bridge
 - Encapsulation: RFC 1483
 - Multiplexing: LLC
 - Virtual Circuit ID: 8
 - VPI: 35
 - VCI: 1
 - Line: 1
 In the 'Service Type' section, the following fields are highlighted with a red circle:
 - Service Mode: 2 wire
 - Service Type: Client
 Other fields in the 'Service Type' section include: Enable Rate Adaption (Enable), Transfer Max Rate(Kbps) (5696), Transfer Min Rate(Kbps) (3200), Standard Mode (ANSI(ANNEX_A)), and Modulation (PAM32).
 At the bottom of the window are three buttons: 'Apply', 'Cancel', and 'Advanced Setup'.

5.2.3 Connect the P-793H v2s

Connect the **DSL** ports on the P-793H v2s together, and wait while the P-793H v2s automatically establish the connection. When the connection is established, the **DSL1**, **DSL2**, and **INTERNET** lights are on. It takes up to half a minute to establish the connection. If the P-793H v2s do not establish the connection, verify that the settings (except the **Service Type**) match.

5.3 Configuring a Point-to-2points Connection

Now Company **A** has another branch office, **C** and wants to set up a point-to-2points connection between a server P-793H v2 on **A**'s side and client P-793H v2s at **B** and **C**. The maximum transfer rate for the DSL connection between **A** and **B** is **5696** Kbps and the minimum transfer rate is **3200** Kbps. The maximum transfer rate for the DSL connection between **A** and **C** is **2560** Kbps and minimum transfer rate is **1280** Kbps.

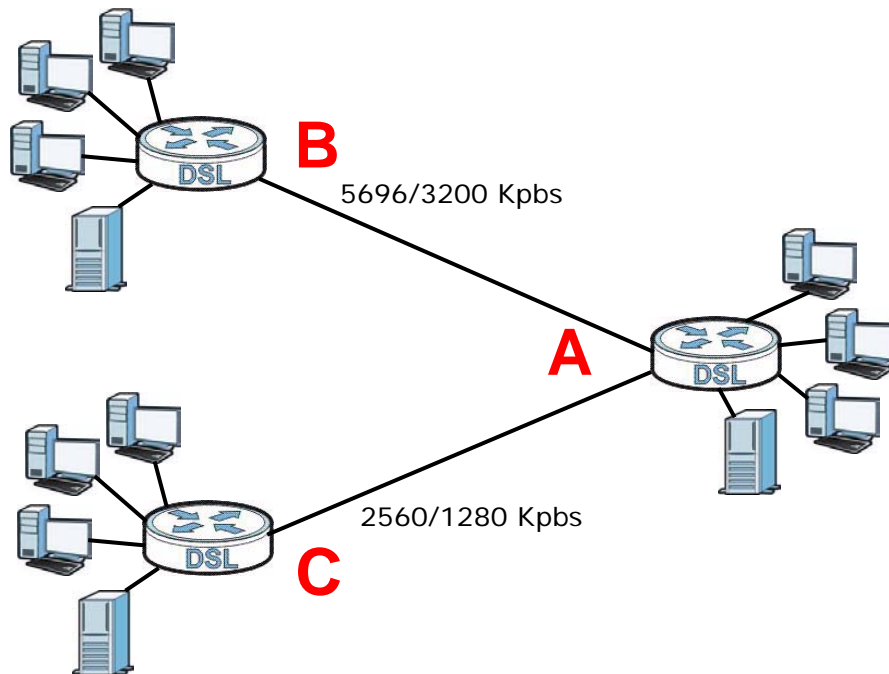

To set up the point-to-2 point connection between **A**, **B** and **C** you need to:

- 1 Set up the Server.
- 2 Set up the Clients.
- 3 Connect the P-793H v2s.

5.3.1 Set up the Server

- 1 Log in to the server P-793H v2 of Company **A**.
- 2 Click **Network > WAN > Internet Access Setup**.

- Configure the **Internet Access Setup** screen as the following. Select **ATM** as the **Transfer Mode**. Select **Bridge** as the **Mode**. Configure the **Multiplexing, Encapsulation, VPI**, and **VCI** fields for the point-to-point connection. Select **1** in the **Line** field as the DSL line you want the P-793H v2 to use as a default for outgoing traffic.
- Then configure the **Service Type** section. Select **2 wire-2 line** in the **Service Mode** field. In the **Service Type** field, select **Server**. For Line1 configuration, select **5696** as the **Transfer Max Rate** and **3200** as the **Transfer Min Rate**. For Line2 configuration, select **2560** as the **Transfer Max Rate** and **1280** as the **Transfer Min Rate**. Leave the rest of the fields to their default settings. Click **Apply**.

Figure 24 WAN > Internet Access Setup

The screenshot displays the 'Internet Access Setup' configuration page. It is divided into several sections: 'General', 'DNS server', 'Service Type', and 'Line1/Line2'. The 'General' section is highlighted with a red box and contains the following settings: Transfer Mode (ATM), Mode (Bridge), Encapsulation (RFC 1483), Multiplexing (LLC), VPI (8), VCI (35), and Line (1). The 'Service Type' section shows Service Mode (2wire-2line) and Service Type (Server). The 'Line1' and 'Line2' sections are also highlighted with a red box and show settings for Enable Rate Adaption (Enable), Transfer Max Rate (Kbps), Transfer Min Rate (Kbps), and Standard Mode (ANSI(ANNEX_A)). At the bottom, there are buttons for 'Apply', 'Cancel', and 'Advanced Setup'.

5.3.2 Set up the Clients

- Log in to the client P-793H v2 of branch office **B**.
- Click **Network > WAN > Internet Access Setup**.

- 3 Select **ATM** as the **Transfer Mode**. Set the **VPI**, **VCI**, **Multiplexing**, and **Encapsulation** to the same values you set in the server.
- 4 Scroll down to the **Service Type** section. In the **Service Mode** field, select **2 wire**. In the **Service Type** field, select **Client**. The rest of the fields will be negotiated with the server. Click **Apply**.

Figure 25 WAN > Internet Connection > Service Type of B

Service Type	
Service Mode	2 wire
Service Type	Client
Enable Rate Adaption	Enable
Transfer Max Rate(Kbps)	5696
Transfer Min Rate(Kbps)	3200
Standard Mode	ANSI(ANNEX_A)
Modulation	PAM32

Buttons: Apply, Cancel, Advanced Setup

- 5 Repeat the above steps 1 to 4 for the second client P-793H v2 on **C**'s side. The **Service Type** should look like the following.

Figure 26 WAN > Internet Connection > Service Type of C

Service Type	
Service Mode	2 wire
Service Type	Client
Enable Rate Adaption	Enable
Transfer Max Rate(Kbps)	2560
Transfer Min Rate(Kbps)	1280
Standard Mode	ANSI(ANNEX_A)
Modulation	PAM32

Buttons: Apply, Cancel, Advanced Setup

5.3.3 Connect the P-793H v2s

Connect the **DSL** ports on the P-793H v2s together, and wait while the P-793H v2s automatically establish the connection. Make sure that the Y-cable is connected to the proper DSL outlets. The Y-cable connector marked **DSL1** must be connected to the outgoing DSL 1 telephone jack and the Y-cable connector marked **DSL2** must be connected to the outgoing DSL 2 telephone jack.

When the connection is established, the **DSL1**, **DSL2**, and **INTERNET** lights turn on. It takes up to half a minute to establish the connection. If the P-793H v2s do not establish the connection, verify that the settings are correct.

PART II

Technical Reference

WAN Setup

6.1 Overview

This chapter describes how to configure WAN settings from the **WAN** screens. Use these screens to configure your P-793H v2 for Internet access.

A WAN (Wide Area Network) connection is an outside connection to another network or the Internet. It connects your private networks (such as a LAN (Local Area Network)) and other networks, so that a computer in one location can communicate with computers in other locations.

Figure 27 LAN and WAN

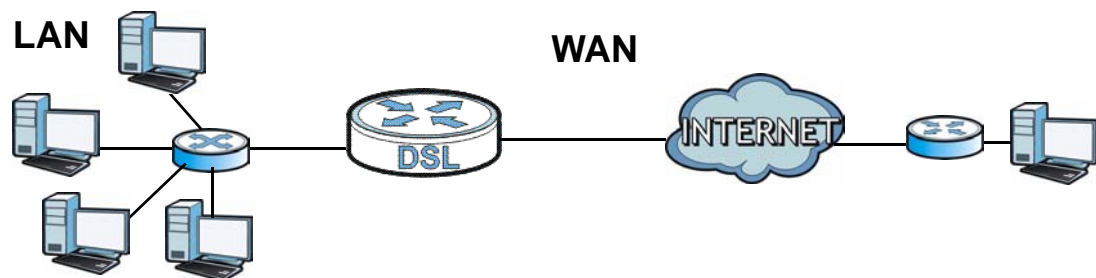

6.1.1 What You Can Do in the WAN Screens

- Use the **Internet Access Setup** screen ([Section 6.2 on page 78](#)) to configure the WAN settings on the P-793H v2 for Internet access.
- Use the **More Connections** screen ([Section 6.3 on page 86](#)) to set up additional Internet access connections.
- Use the **WAN Backup Setup** screen ([Section 6.4 on page 92](#)) to set up a backup gateway that helps forward traffic to its destination when the default WAN connection is down.

6.1.2 What You Need to Know About WAN

Encapsulation Method

Encapsulation is used to include data from an upper layer protocol into a lower layer protocol. To set up a WAN connection to the Internet, you need to use the same encapsulation method used by your ISP (Internet Service Provider). If your ISP offers a dial-up Internet connection using PPPoE (PPP over Ethernet) or PPPoA, they should also provide a username and password (and service name) for user authentication.

WAN IP Address

The WAN IP address is an IP address for the P-793H v2, which makes it accessible from an outside network. It is used by the P-793H v2 to communicate with other devices in other networks. It can be static (fixed) or dynamically assigned by the ISP each time the P-793H v2 tries to access the Internet.

If your ISP assigns you a static WAN IP address, they should also assign you the subnet mask and DNS server IP address(es) (and a gateway IP address if you use the Ethernet or ENET ENCAP encapsulation method).

ATM

Asynchronous Transfer Mode (ATM) is a LAN and WAN networking technology that provides high-speed data transfer. ATM uses fixed-size packets of information called cells. With ATM, a high QoS (Quality of Service) can be guaranteed. ATM uses a connection-oriented model and establishes a virtual circuit (VC) between two endpoints before the actual data exchange begins.

PTM

Packet Transfer Mode (PTM) is packet-oriented and supported by the VDSL2 standard. In PTM, packets are encapsulated directly in the High-level Data Link Control (HDLC) frames. It is designed to provide a low-overhead, transparent way of transporting packets over DSL links, as an alternative to ATM.

Multicast

Traditionally, IP packets are transmitted in one of either two ways - Unicast (1 sender - 1 recipient) or Broadcast (1 sender - everybody on the network). Multicast delivers IP packets to a group of hosts on the network - not everybody and not just one.

IGMP

IGMP (Internet Group Multicast Protocol) is a network-layer protocol used to establish membership in a Multicast group - it is not used to carry user data. There are three versions of IGMP. IGMP version 2 and 3 are improvements over version 1, but IGMP version 1 and 2 are still in wide use.

Finding Out More

See [Section 6.5 on page 93](#) for technical background information on WAN.

6.1.3 Before You Begin

You need to know your Internet access settings such as encapsulation and WAN IP address. Get this information from your ISP.

6.2 The Internet Access Setup Screen

Use this screen to change your P-793H v2's WAN settings. Click **Network > WAN > Internet Access Setup**. The screen differs by the WAN type and encapsulation you select.

Figure 28 Network > WAN > Internet Access Setup

The screenshot shows the 'Internet Access Setup' configuration window. It has three tabs: 'Internet Access Setup' (selected), 'More Connections', and 'WAN Backup Setup'. The configuration is organized into five main sections:

- General:** Transfer Mode (ATM), Mode (Routing), Encapsulation (PPPoE), User Name (user), Password (masked), Service Name (empty), Multiplexing (LLC), Virtual Circuit ID (VPI: 8, VCI: 35), Line (2).
- IP Address:** Radio buttons for 'Obtain an IP Address Automatically' (selected) and 'Static IP Address'. The IP Address field contains '0.0.0.0'.
- DNS server:** First DNS Server (None, 0.0.0.0), Second DNS Server (None, 0.0.0.0), Third DNS Server (Obtained From ISP, 0.0.0.0).
- Connection:** Radio buttons for 'Nailed-Up Connection' and 'Connect on Demand' (selected). Max Idle Timeout is set to 0 sec.
- Service Type:** Service Mode (2 wire), Service Type (Server), Enable Rate Adaption (Enable), Transfer Max Rate(Kbps) (5696), Transfer Min Rate(Kbps) (192), Standard Mode (ANS(ANNEX_A)), Modulation (PAM32).

At the bottom of the window are three buttons: 'Apply', 'Cancel', and 'Advanced Setup'.

The following table describes the labels in this screen.

Table 12 Network > WAN > Internet Access Setup

LABEL	DESCRIPTION
General	
Transfer Mode	<p>Select the transfer mode you want to use.</p> <p>PTM (Packet Transfer Mode): The P-793H v2 uses the SHDSL technology for data transmission over the DSL port.</p> <p>ATM (Asynchronous Transfer Mode): The P-793H v2 uses the ADSL technology for data transmission over the DSL port.</p>
Mode	<p>Select Routing (default) from the drop-down list box if your ISP gives you one IP address only and you want multiple computers to share an Internet account. Select Bridge when your ISP provides you more than one IP address and you want the connected computers to get individual IP address from ISP's DHCP server directly. If you select Bridge, you cannot use Firewall, DHCP server and NAT on the P-793H v2.</p>
Encapsulation	<p>Select the method of encapsulation used by your ISP from the drop-down list box. Choices vary depending on the mode you select in the Mode field.</p> <p>If you select Bridge in the Mode field, select either PPPoA or RFC 1483.</p> <p>If you select Routing in the Mode field, select PPPoA, RFC 1483, ENET ENCAP or PPPoE.</p> <p>If you set up a point-to-point or a point-to-2points connection, select either ENET ENCAP or RFC 1483.</p>
User Name	<p>(PPPoA and PPPoE encapsulation only) Enter the user name exactly as your ISP assigned. If assigned a name in the form user@domain where domain identifies a service name, then enter both components exactly as given.</p>
Password	<p>(PPPoA and PPPoE encapsulation only) Enter the password associated with the user name above.</p>
Service Name	<p>(PPPoE only) Type the name of your PPPoE service here.</p>
Multiplexing	<p>Select the method of multiplexing used by your ISP from the drop-down list. Choices are VC or LLC.</p> <p>This is available only when you select ATM in the Transfer Mode field.</p>
Virtual Circuit ID	<p>VPI (Virtual Path Identifier) and VCI (Virtual Channel Identifier) define a virtual circuit. Refer to the appendix for more information.</p> <p>This is available only when you select ATM in the Transfer Mode field.</p>
VPI	<p>The valid range for the VPI is 0 to 255. Enter the VPI assigned to you.</p>
VCI	<p>The valid range for the VCI is 32 to 65535 (0 to 31 is reserved for local management of ATM traffic). Enter the VCI assigned to you.</p>

Table 12 Network > WAN > Internet Access Setup (continued)

LABEL	DESCRIPTION
Tag VLAN ID for egress packets	<p>Select this option to add the VLAN tag (specified below) to the outgoing traffic through this connection.</p> <p>This is available only when you select PTM in the Transfer Mode field.</p>
Enter 802.1P Priority	<p>IEEE 802.1p defines up to 8 separate traffic types by inserting a tag into a MAC-layer frame that contains bits to define class of service.</p> <p>Type the IEEE 802.1p priority level (from 0 to 7) to add to traffic through this connection. The greater the number, the higher the priority level.</p>
Enter 802.1Q VLAN ID	Type the VLAN ID number (from 1 to 4094) for traffic through this connection.
Line	Select the DSL line you want the P-793H v2 to use as a default for outgoing traffic (remote node 1).
IP Address	<p>This option is available if you select Routing in the Mode field.</p> <p>A static IP address is a fixed IP that your ISP gives you. A dynamic IP address is not fixed; the ISP assigns you a different one each time you connect to the Internet.</p> <p>Select Obtain an IP Address Automatically if you have a dynamic IP address; otherwise select Static IP Address and type your ISP assigned IP address in the IP Address field below.</p>
Subnet Mask	<p>This option is available if you select ENET ENCAP in the Encapsulation field.</p> <p>Enter a subnet mask in dotted decimal notation.</p>
Gateway IP address	<p>This option is available if you select ENET ENCAP in the Encapsulation field.</p> <p>Specify a gateway IP address (supplied by your ISP).</p>
DNS Server	
First DNS Server Second DNS Server Third DNS Server	<p>Select Obtained From ISP if your ISP dynamically assigns DNS server information (and the P-793H v2's WAN IP address) and you select Obtain an IP Address Automatically.</p> <p>Select User-Defined if you have the IP address of a DNS server. Enter the DNS server's IP address in the field to the right. If you chose User-Defined, but leave the IP address set to 0.0.0.0, User-Defined changes to None after you click Apply. If you set a second choice to User-Defined, and enter the same IP address, the second User-Defined changes to None after you click Apply.</p> <p>Select None if you do not want to configure DNS servers. You must have another DNS server on your LAN, or else the computers must have their DNS server addresses manually configured. If you do not configure a DNS server, you must know the IP address of a computer in order to access it.</p>
Connection (PPPoA and PPPoE encapsulation only)	
Nailed-Up Connection	Select Nailed-Up Connection when you want your connection up all the time. The P-793H v2 will try to bring up the connection automatically if it is disconnected.

Table 12 Network > WAN > Internet Access Setup (continued)

LABEL	DESCRIPTION
Connect on Demand	Select Connect on Demand when you don't want the connection up all the time and specify an idle time-out in the Max Idle Timeout field.
Max Idle Timeout	Specify an idle time-out in the Max Idle Timeout field when you select Connect on Demand . The default setting is 0, which means the Internet session will not timeout.
Service Type	
Service Mode	Select 2-wire , 4-wire or 2wire-2line mode for the DSL connection. This depends on the network configuration you want to set up and the phone lines you use. Service mode affects the maximum speed of the connection. In 2-wire mode, the maximum data rate is up to 5.69 Mbps, while in 4-wire mode, the maximum data rate is up to 11.38 Mbps. In 2wire-2line mode the maximum data rate is 5.69 Mbps for each line. See Section 6.2.1 on page 82 for more information on configuring 2wire-2line mode.
Service Type	Indicate whether the P-793H v2 is the server or the client in the DSL connection. Select Server if this P-793H v2 is the server in a point-to-point application. Otherwise, select Client . This field is not configurable if you select 2wire-2line mode because the ZyXEL Device is automatically set to Server .
Enable Rate Adaption	This field is enabled if Service Type is Server . Indicate whether or not the P-793H v2 can adjust the speed of its connection to that of the other device.
Transfer Max Rate (Kbps)	This field is enabled if Service Type is Server . Set the maximum rate at which the P-793H v2 sends and receives information. The actual transfer rate will be between this value and the minimum transfer rate you configure. When you select 4-wire in the Service Mode field, then the transfer rate you set here is doubled. For example, select 5696 Kbps to configure a maximum transfer rate of 11392 Kbps.
Transfer Min Rate (Kbps)	This field is enabled if Service Type is Server . Set the minimum rate at which the P-793H v2 sends and receives information. The actual transfer rate will be between this value and the maximum transfer rate you configure. When you select 4-wire in the Service Mode field, then the transfer rate you set here is doubled. For example, select 192 Kbps to configure a minimum transfer rate of 384 Kbps.
Standard Mode	This field is enabled if Service Type is Server . Select the operational mode the P-793H v2 uses in the DSL connection. ANSI (ANNEX_A) refers to connections over POTS and ETSI (ANNEX_B) refers to connections over ISDN lines.
Modulation	Select the modulation supported by your ISP.
Apply	Click this to save your changes.
Cancel	Click this to restore your previously saved settings.
Advanced Setup	Click this to display the Advanced WAN Setup screen and edit more details of your WAN setup.

6.2.1 2Wire-2Line Service Mode

The **Service Mode** section of the **Internet Connection** screen allows you to set up two DSL connections when you select **2wire-2line** mode. This allows you to create a point-to-points configuration.

Figure 29 2wire-2line Service Mode

The following table describes the labels in this screen.

Table 13 2wire-2line Service Mode

LABEL	DESCRIPTION
Service Type	
Service Mode	Select 2wire-2line mode for the DSL connection. This means that the P-793H v2 is going to be a server connected to two client P-793H v2s.
Service Type	When you select 2wire-2line mode this field automatically changes to Server .
Line1 / Line 2	You can configure different connection rate settings for Line 1 and Line 2 DSL connections.
Enable Rate Adaption	Indicate whether or not the P-793H v2 can adjust the speed of its connection to that of the other device.
Transfer Max Rate (Kbps)	This field is enabled if Service Type is Server . Set the maximum rate at which the P-793H v2 sends and receives information. The actual transfer rate will be between this value and the minimum transfer rate you configure.
Transfer Min Rate (Kbps)	This field is enabled if Service Type is Server . Set the minimum rate at which the P-793H v2 sends and receives information. The actual transfer rate will be between this value and the maximum transfer rate you configure.
Standard Mode	Select the operational mode the P-793H v2 uses in the DSL connection. Annex A refers to connections over POTS and Annex B refers to connections over ISDN lines.
Apply	Click Apply to save the changes.

Table 13 2wire-2line Service Mode (continued)

LABEL	DESCRIPTION
Cancel	Click Cancel to begin configuring this screen afresh.
Advanced Setup	Click this button to display the Advanced WAN Setup screen and edit more details of your WAN setup.

6.2.2 Advanced Internet Access Setup

Use this screen to edit your P-793H v2's advanced WAN settings. Click the **Advanced Setup** button in the **Internet Access Setup** screen. The screen appears as shown.

Figure 30 Network > WAN > Internet Access Setup: Advanced Setup

The screenshot displays the 'Advanced Setup' screen for WAN configuration. It is organized into several sections:

- RIP & Multicast Setup:** Includes dropdown menus for 'RIP Direction' (set to None), 'RIP Version' (set to N/A), and 'Multicast' (set to IGMP-v1).
- ATM QoS:** Includes 'ATM QoS Type' (set to UBR), 'Peak Cell Rate' (8304 cell/sec), 'Sustain Cell Rate' (26735 cell/sec), 'Maximum Burst Size' (28261 cell), and 'PPPoE Passthrough' (set to Yes).
- MTU:** A text input field for 'MTU' set to 1492.
- Packet Filter:** Includes 'Incoming Filter Sets' and 'Outgoing Filter Sets', each with 'Protocol Filter' and 'Generic Filter' dropdowns, all currently set to 'None'.

At the bottom right, there are three buttons: 'Back', 'Apply', and 'Cancel'.

The following table describes the labels in this screen.

Table 14 Network > WAN > Internet Access Setup: Advanced Setup

LABEL	DESCRIPTION
RIP & Multicast Setup	This section is not available when you configure the P-793H v2 to be in bridge mode.
RIP Direction	RIP (Routing Information Protocol) allows a router to exchange routing information with other routers. Use this field to control how much routing information the P-793H v2 sends and receives on the subnet. Select the RIP direction from None , Both , In Only and Out Only .

Table 14 Network > WAN > Internet Access Setup: Advanced Setup (continued)

LABEL	DESCRIPTION
RIP Version	<p>This field is not configurable if you select None in the RIP Direction field.</p> <p>Select the RIP version from RIP-1, RIP-2B and RIP-2M.</p>
Multicast	<p>Multicast packets are sent to a group of computers on the LAN and are an alternative to unicast packets (packets sent to one computer) and broadcast packets (packets sent to every computer).</p> <p>Internet Group Multicast Protocol (IGMP) is a network-layer protocol used to establish membership in a multicast group. The P-793H v2 supports IGMP-v1, IGMP-v2 and IGMP-v3. Select None to disable it.</p>
ATM QoS	
ATM QoS Type	<p>Select CBR (Continuous Bit Rate) to specify fixed (always-on) bandwidth for voice or data traffic. Select UBR (Unspecified Bit Rate) for applications that are non-time sensitive, such as e-mail. Select VBR-RT (real-time Variable Bit Rate) type for applications with bursty connections that require closely controlled delay and delay variation. Select VBR-nRT (non real-time Variable Bit Rate) type for connections that do not require closely controlled delay and delay variation.</p>
Peak Cell Rate	<p>Divide the DSL line rate (bps) by 424 (the size of an ATM cell) to find the Peak Cell Rate (PCR). This is the maximum rate at which the sender can send cells. Type the PCR here.</p>
Sustain Cell Rate	<p>The Sustain Cell Rate (SCR) sets the average cell rate (long-term) that can be transmitted. Type the SCR, which must be less than the PCR. Note that system default is 0 cells/sec.</p>
Maximum Burst Size	<p>Maximum Burst Size (MBS) refers to the maximum number of cells that can be sent at the peak rate. Type the MBS, which is less than 65535.</p>
PPPoE Passthrough (PPPoE encapsulation only)	<p>This field is available when you select PPPoE encapsulation.</p> <p>In addition to the P-793H v2's built-in PPPoE client, you can enable PPPoE pass through to allow up to ten hosts on the LAN to use PPPoE client software on their computers to connect to the ISP via the P-793H v2. Each host can have a separate account and a public WAN IP address.</p> <p>PPPoE pass through is an alternative to NAT for application where NAT is not appropriate.</p> <p>Disable PPPoE pass through if you do not need to allow hosts on the LAN to use PPPoE client software on their computers to connect to the ISP.</p>
MTU	

Table 14 Network > WAN > Internet Access Setup: Advanced Setup (continued)

LABEL	DESCRIPTION
MTU	<p>The Maximum Transmission Unit (MTU) defines the size of the largest packet allowed on an interface or connection. Enter the MTU in this field.</p> <p>For ENET ENCAP, the MTU value is 1500.</p> <p>For PPPoE, the MTU value is 1492.</p> <p>For PPPoA and RFC 1483, the MTU is 65535.</p>
Packet Filter	
Incoming Filter Sets	
Protocol Filter	<p>Select the protocol filter(s) to control incoming traffic. You may choose up to 4 sets of filters.</p> <p>You can configure packet filters in the Packet Filter screen. See Chapter 12 on page 217 for more details.</p>
Generic Filter	<p>Select the generic filter(s) to control incoming traffic. You may choose up to 4 sets of filters.</p> <p>You can configure generic filters in the Packet Filter screen. See Chapter 12 on page 217 for more details.</p>
Outgoing Filter Sets	
Protocol Filter	<p>Select the protocol filter(s) to control outgoing traffic. You may choose up to 4 sets of filters.</p> <p>You can configure protocol filters in the Packet Filter screen. See Chapter 12 on page 217 for more details.</p>
Generic Filter	<p>Select the generic filter(s) to control outgoing traffic. You may choose up to 4 sets of filters.</p> <p>You can configure generic filters in the Packet Filter screen. See Chapter 12 on page 217 for more details.</p>
Back	Click this to return to the previous screen without saving.
Apply	Click this to save your changes.
Cancel	Click this to restore your previously saved settings.

6.3 The More Connections Screen

The P-793H v2 allows you to configure more than one Internet access connection. To configure additional Internet access connections click **Network > WAN > More Connections**. The screen differs by the encapsulation you select. When you use the **WAN > Internet Access Setup** screen to set up Internet access, you are configuring the first WAN connection.

Figure 31 Network > WAN > More Connections

#	Active	Name:	VPI/VCI	Encapsulation	Modify
1		Internet Connection	8/35	ENET ENCAP	
2	-	--	--	--	
3	-	--	--	--	
4	-	--	--	--	
5	-	--	--	--	
6	-	--	--	--	
7	-	--	--	--	
8	-	--	--	--	

The following table describes the labels in this screen.

Table 15 Network > WAN > More Connections

LABEL	DESCRIPTION
#	This is an index number indicating the number of the corresponding connection.
Active	This field indicates whether the connection is active or not.
Name	This is the name you gave to the Internet connection.
VPI/VCI	This field displays the Virtual Path Identifier (VPI) and Virtual Channel Identifier (VCI) numbers configured for this WAN connection.
Encapsulation	This field indicates the encapsulation method of the Internet connection.
Modify	<p>The first (ISP) connection is read-only in this screen. Use the WAN > Internet Access Setup screen to edit it.</p> <p>Click the Edit icon to edit the Internet connection settings. Click this icon on an empty configuration to add a new Internet access setup.</p> <p>Click the Remove icon to delete the Internet access setup from your connection list.</p>
Apply	Click this to save your changes.
Cancel	Click this to restore your previously saved settings.

6.3.1 More Connections Edit

Use this screen to configure a connection. Click the edit icon in the **More Connections** screen to display the following screen.

Figure 32 Network > WAN > More Connections: Edit

The following table describes the labels in this screen.

Table 16 Network > WAN > More Connections: Edit

LABEL	DESCRIPTION
General	
Active	Select the check box to activate or clear the check box to deactivate this connection.
Name	Enter a unique, descriptive name of up to 13 ASCII characters for this connection.
Mode	Select Routing from the drop-down list box if your ISP allows multiple computers to share an Internet account. If you select Bridge , the P-793H v2 will forward any packet that it does not route to this remote node; otherwise, the packets are discarded.

Table 16 Network > WAN > More Connections: Edit (continued)

LABEL	DESCRIPTION
Encapsulation	<p>Select the method of encapsulation used by your ISP from the drop-down list box. Choices vary depending on the mode you select in the Mode field.</p> <p>If you select Bridge in the Mode field, select either PPPoA or RFC 1483.</p> <p>If you select Routing in the Mode field, select PPPoA, RFC 1483, ENET ENCAP or PPPoE.</p> <p>If you set up a point-to-point connection, select either ENET ENCAP or RFC 1483.</p>
User Name	(PPPoA and PPPoE encapsulation only) Enter the user name exactly as your ISP assigned. If assigned a name in the form user@domain where domain identifies a service name, then enter both components exactly as given.
Password	(PPPoA and PPPoE encapsulation only) Enter the password associated with the user name above.
Service Name	(PPPoE only) Type the name of your PPPoE service here.
Multiplexing	<p>Select the method of multiplexing used by your ISP from the drop-down list. Choices are VC or LLC.</p> <p>By prior agreement, a protocol is assigned a specific virtual circuit, for example, VC1 will carry IP. If you select VC, specify separate VPI and VCI numbers for each protocol.</p> <p>For LLC-based multiplexing or PPP encapsulation, one VC carries multiple protocols with protocol identifying information being contained in each packet header. In this case, only one set of VPI and VCI numbers need be specified for all protocols.</p>
VPI	The valid range for the VPI is 0 to 255. Enter the VPI assigned to you.
VCI	The valid range for the VCI is 32 to 65535 (0 to 31 is reserved for local management of ATM traffic). Enter the VCI assigned to you.
Line	Select the DSL line you want the P-793H v2 to use as a default for outgoing traffic (remote node 1).
IP Address	<p>This option is available if you select Routing in the Mode field.</p> <p>A static IP address is a fixed IP that your ISP gives you. A dynamic IP address is not fixed; the ISP assigns you a different one each time you connect to the Internet.</p> <p>If you use the encapsulation type except RFC 1483, select Obtain an IP Address Automatically when you have a dynamic IP address; otherwise select Static IP Address and type your ISP assigned IP address in the IP Address field below.</p> <p>If you use RFC 1483, enter the IP address given by your ISP in the IP Address field.</p>
Subnet Mask	Enter a subnet mask in dotted decimal notation.
Gateway IP address	Specify a gateway IP address (supplied by your ISP).
Connection	

Table 16 Network > WAN > More Connections: Edit (continued)

LABEL	DESCRIPTION
Nailed-Up Connection	Select Nailed-Up Connection when you want your connection up all the time. The P-793H v2 will try to bring up the connection automatically if it is disconnected.
Connect on Demand	Select Connect on Demand when you don't want the connection up all the time and specify an idle time-out in the Max Idle Timeout field.
Max Idle Timeout	Specify an idle time-out in the Max Idle Timeout field when you select Connect on Demand . The default setting is 0, which means the Internet session will not timeout.
NAT	<p>SUA only is available only when you select Routing in the Mode field.</p> <p>Select SUA Only if you have one public IP address and want to use NAT. Click Edit Detail to go to the Port Forwarding screen to edit a server mapping set.</p> <p>Otherwise, select None to disable NAT.</p>
Back	Click this to return to the previous screen without saving.
Apply	Click this to save your changes.
Cancel	Click this to restore your previously saved settings.
Advanced Setup	Click this to display the More Connections Advanced Setup screen and edit more details of your WAN setup.

6.3.2 Configuring More Connections Advanced Setup

Use this screen to edit your P-793H v2's advanced WAN settings. Click the **Advanced Setup** button in the **More Connections Edit** screen. The screen appears as shown.

Figure 33 Network > WAN > More Connections: Edit: Advanced Setup

The screenshot shows the 'Advanced Setup' configuration screen for WAN connections. It is organized into four main sections:

- RIP & Multicast Setup:** Contains three dropdown menus: 'RIP Direction' (set to 'None'), 'RIP Version' (set to 'N/A'), and 'Multicast' (set to 'None').
- ATM QoS:** Contains three input fields: 'ATM QoS Type' (dropdown set to 'UBR'), 'Peak Cell Rate' (input '0' cell/sec), 'Sustain Cell Rate' (input '0' cell/sec), and 'Maximum Burst Size' (input '0' cell).
- MTU:** Contains one input field for 'MTU' (set to '1500').
- Packet Filter:** Contains two groups of settings: 'Incoming Filter Sets' and 'Outgoing Filter Sets'. Each group has 'Protocol Filter' and 'Generic Filter' dropdown menus, all currently set to 'None'. At the bottom are 'Back', 'Apply', and 'Cancel' buttons.

The following table describes the labels in this screen.

Table 17 Network > WAN > More Connections: Edit: Advanced Setup

LABEL	DESCRIPTION
RIP & Multicast Setup	This section is not available when you configure the P-793H v2 to be in bridge mode.
RIP Direction	Select the RIP direction from None , Both , In Only and Out Only .
RIP Version	Select the RIP version from RIP-1 , RIP-2B and RIP-2M .
Multicast	IGMP (Internet Group Multicast Protocol) is a network-layer protocol used to establish membership in a multicast group. The P-793H v2 supports IGMP-v1 , IGMP-v2 and IGMP-v3 . Select None to disable it.
ATM QoS	
ATM QoS Type	Select CBR (Continuous Bit Rate) to specify fixed (always-on) bandwidth for voice or data traffic. Select UBR (Unspecified Bit Rate) for applications that are non-time sensitive, such as e-mail. Select VBR-nRT (Variable Bit Rate-non Real Time) or VBR-RT (Variable Bit Rate-Real Time) for bursty traffic and bandwidth sharing with other applications.

Table 17 Network > WAN > More Connections: Edit: Advanced Setup (continued)

LABEL	DESCRIPTION
Peak Cell Rate	Divide the DSL line rate (bps) by 424 (the size of an ATM cell) to find the Peak Cell Rate (PCR). This is the maximum rate at which the sender can send cells. Type the PCR here.
Sustain Cell Rate	The Sustain Cell Rate (SCR) sets the average cell rate (long-term) that can be transmitted. Type the SCR, which must be less than the PCR. Note that system default is 0 cells/sec.
Maximum Burst Size	Maximum Burst Size (MBS) refers to the maximum number of cells that can be sent at the peak rate. Type the MBS, which is less than 65535.
MTU	
MTU	The Maximum Transmission Unit (MTU) defines the size of the largest packet allowed on an interface or connection. Enter the MTU in this field. For ENET ENCAP, the MTU value is 1500. For PPPoE, the MTU value is 1492. For PPPoA and RFC, the MTU is 65535.
Packet Filter	
Incoming Filter Sets	
Protocol Filter	Select the protocol filter(s) to control incoming traffic. You may choose up to 4 sets of filters. You can configure packet filters in the Packet Filter screen. See Chapter 12 on page 217 for more details.
Generic Filter	Select the generic filter(s) to control incoming traffic. You may choose up to 4 sets of filters. You can configure generic filters in the Packet Filter screen. See Chapter 12 on page 217 for more details.
Outgoing Filter Sets	
Protocol Filter	Select the protocol filter(s) to control outgoing traffic. You may choose up to 4 sets of filters. You can configure protocol filters in the Packet Filter screen. See Chapter 12 on page 217 for more details.
Generic Filter	Select the generic filter(s) to control outgoing traffic. You may choose up to 4 sets of filters. You can configure generic filters in the Packet Filter screen. See Chapter 12 on page 217 for more details.
Back	Click this to return to the previous screen without saving.
Apply	Click this to save your changes.
Cancel	Click this to restore your previously saved settings.

6.4 The WAN Backup Setup Screen

Use this screen to configure your P-793H v2's WAN backup. Click **Network > WAN > WAN Backup Setup**. This screen is not available if you set the WAN type to **Ethernet** in the **Internet Access Setup** screen.

Figure 34 Network > Internet (WAN) > WAN Backup

The following table describes the labels in this screen.

Table 18 Network > Internet (WAN) > WAN Backup

LABEL	DESCRIPTION
Backup Type	Select the method that the P-793H v2 uses to check the DSL connection. Select DSL Link to have the P-793H v2 check if the connection to the DSLAM is up. Select ICMP to have the P-793H v2 periodically ping the IP addresses configured in the Check WAN IP Address fields.
Check WAN IP Address 1-3	Configure this field to test your P-793H v2's WAN accessibility. Type the IP address of a reliable nearby computer (for example, your ISP's DNS server address). If you activate either traffic redirect or dial backup, you must configure at least one IP address here. When using a WAN backup connection, the P-793H v2 periodically pings the addresses configured here and uses the other WAN backup connection (if configured) if there is no response.
Fail Tolerance	Type the number of times (2 recommended) that your P-793H v2 may ping the IP addresses configured in the Check WAN IP Address field without getting a response before switching to a WAN backup connection (or a different WAN backup connection).

Table 18 Network > Internet (WAN) > WAN Backup

LABEL	DESCRIPTION
Recovery Interval	When the P-793H v2 is using a lower priority connection (usually a WAN backup connection), it periodically checks whether or not it can use a higher priority connection. Type the number of seconds (30 recommended) for the P-793H v2 to wait between checks. Allow more time if your destination IP address handles lots of traffic.
Timeout	Type the number of seconds (3 recommended) for your P-793H v2 to wait for a ping response from one of the IP addresses in the Check WAN IP Address field before timing out the request. The WAN connection is considered "down" after the P-793H v2 times out the number of times specified in the Fail Tolerance field. Use a higher value in this field if your network is busy or congested.
Traffic Redirect	Traffic redirect forwards traffic to a backup gateway when the P-793H v2 cannot connect to the Internet.
Active Traffic Redirect	Select this check box to have the P-793H v2 use traffic redirect if the normal WAN connection goes down. Note: If you activate traffic redirect, you must configure at least one Check WAN IP Address.
Metric	This field sets this route's priority among the routes the P-793H v2 uses. The metric represents the "cost of transmission". A router determines the best route for transmission by choosing a path with the lowest "cost". RIP routing uses hop count as the measurement of cost, with a minimum of "1" for directly connected networks. The number must be between "1" and "15"; a number greater than "15" means the link is down. The smaller the number, the lower the "cost".
Backup Gateway	Type the IP address of your backup gateway in dotted decimal notation. The P-793H v2 automatically forwards traffic to this IP address if the P-793H v2's Internet connection terminates.
Apply	Click Apply to save the changes.
Cancel	Click Cancel to begin configuring this screen afresh.

6.5 WAN Technical Reference

This section provides some technical background information about the topics covered in this chapter.

6.5.1 Encapsulation

Be sure to use the encapsulation method required by your ISP. The P-793H v2 supports the following methods.

6.5.1.1 ENET ENCAP

The MAC Encapsulated Routing Link Protocol (ENET ENCAP) is only implemented with the IP network protocol. IP packets are routed between the Ethernet interface and the WAN interface and then formatted so that they can be understood in a bridged environment. For instance, it encapsulates routed Ethernet frames into bridged ATM cells. ENET ENCAP requires that you specify a gateway IP address in the **Gateway IP Address** field in the wizard or WAN screen. You can get this information from your ISP.

6.5.1.2 PPP over Ethernet

The P-793H v2 supports PPPoE (Point-to-Point Protocol over Ethernet). PPPoE is an IETF Draft standard (RFC 2516) specifying how a personal computer (PC) interacts with a broadband modem (DSL, cable, wireless, etc.) connection. The PPPoE option is for a dial-up connection using PPPoE.

For the service provider, PPPoE offers an access and authentication method that works with existing access control systems (for example RADIUS).

One of the benefits of PPPoE is the ability to let you access one of multiple network services, a function known as dynamic service selection. This enables the service provider to easily create and offer new IP services for individuals.

Operationally, PPPoE saves significant effort for both you and the ISP or carrier, as it requires no specific configuration of the broadband modem at the customer site.

By implementing PPPoE directly on the P-793H v2 (rather than individual computers), the computers on the LAN do not need PPPoE software installed, since the P-793H v2 does that part of the task. Furthermore, with NAT, all of the LANs' computers will have access.

6.5.1.3 PPPoA

PPPoA stands for Point to Point Protocol over ATM Adaptation Layer 5 (AAL5). A PPPoA connection functions like a dial-up Internet connection. The P-793H v2 encapsulates the PPP session based on RFC1483 and sends it through an ATM PVC (Permanent Virtual Circuit) to the Internet Service Provider's (ISP) DSLAM (Digital Subscriber Line (DSL) Access Multiplexer). Please refer to RFC 2364 for more information on PPPoA. Refer to RFC 1661 for more information on PPP.

6.5.1.4 RFC 1483

RFC 1483 describes two methods for Multiprotocol Encapsulation over ATM Adaptation Layer 5 (AAL5). The first method allows multiplexing of multiple protocols over a single ATM virtual circuit (LLC-based multiplexing) and the second

method assumes that each protocol is carried over a separate ATM virtual circuit (VC-based multiplexing). Please refer to RFC 1483 for more detailed information.

6.5.2 Multiplexing

There are two conventions to identify what protocols the virtual circuit (VC) is carrying. Be sure to use the multiplexing method required by your ISP.

VC-based Multiplexing

In this case, by prior mutual agreement, each protocol is assigned to a specific virtual circuit; for example, VC1 carries IP, etc. VC-based multiplexing may be dominant in environments where dynamic creation of large numbers of ATM VCs is fast and economical.

LLC-based Multiplexing

In this case one VC carries multiple protocols with protocol identifying information being contained in each packet header. Despite the extra bandwidth and processing overhead, this method may be advantageous if it is not practical to have a separate VC for each carried protocol, for example, if charging heavily depends on the number of simultaneous VCs.

6.5.3 VPI and VCI

Be sure to use the correct Virtual Path Identifier (VPI) and Virtual Channel Identifier (VCI) numbers assigned to you. The valid range for the VPI is 0 to 255 and for the VCI is 32 to 65535 (0 to 31 is reserved for local management of ATM traffic). Please see the appendix for more information.

6.5.4 IP Address Assignment

A static IP is a fixed IP that your ISP gives you. A dynamic IP is not fixed; the ISP assigns you a different one each time. The Single User Account feature can be enabled or disabled if you have either a dynamic or static IP. However the encapsulation method assigned influences your choices for IP address and ENET ENCAP gateway.

IP Assignment with PPPoA or PPPoE Encapsulation

If you have a dynamic IP, then the **IP Address** and **Gateway IP Address** fields are not applicable (N/A). If you have a static IP, then you only need to fill in the **IP Address** field and not the **Gateway IP Address** field.

IP Assignment with RFC 1483 Encapsulation

In this case the IP address assignment must be static.

IP Assignment with ENET ENCAP Encapsulation

In this case you can have either a static or dynamic IP. For a static IP you must fill in all the **IP Address** and **Gateway IP Address** fields as supplied by your ISP. However for a dynamic IP, the P-793H v2 acts as a DHCP client on the WAN port and so the **IP Address** and **Gateway IP Address** fields are not applicable (N/A) as the DHCP server assigns them to the P-793H v2.

6.5.5 Nailed-Up Connection (PPP)

A nailed-up connection is a dial-up line where the connection is always up regardless of traffic demand. The P-793H v2 does two things when you specify a nailed-up connection. The first is that idle timeout is disabled. The second is that the P-793H v2 will try to bring up the connection when turned on and whenever the connection is down. A nailed-up connection can be very expensive for obvious reasons.

Do not specify a nailed-up connection unless your telephone company offers flat-rate service or you need a constant connection and the cost is of no concern.

6.5.6 NAT

NAT (Network Address Translation - NAT, RFC 1631) is the translation of the IP address of a host in a packet, for example, the source address of an outgoing packet, used within one network to a different IP address known within another network.

6.6 Metric

The metric represents the "cost of transmission". A router determines the best route for transmission by choosing a path with the lowest "cost". RIP routing uses hop count as the measurement of cost, with a minimum of "1" for directly connected networks. The number must be between "1" and "15"; a number greater than "15" means the link is down. The smaller the number, the lower the "cost".

The metric sets the priority for the P-793H v2's routes to the Internet. If any two of the default routes have the same metric, the P-793H v2 uses the following pre-defined priorities:

- Normal route: designated by the ISP (see [Section 6.2 on page 78](#))
- Traffic-redirect route (see [Section 6.7 on page 97](#))

For example, if the normal route has a of "1" and the traffic-redirect route has a metric of "2", then the normal route acts as the primary default route. If the normal route fails to connect to the Internet, the P-793H v2 tries the traffic-redirect route next.

If you want the traffic-redirect route route to take priority over the normal route, all you need to do is set the traffic-redirect route's metric to "1" and the normal route to "2".

IP Policy Routing overrides the default routing behavior and takes priority over all of the routes mentioned above.

6.7 Traffic Redirect

Traffic redirect forwards traffic to a backup gateway when the P-793H v2 cannot connect to the Internet. An example is shown in the figure below.

Figure 35 Traffic Redirect Example

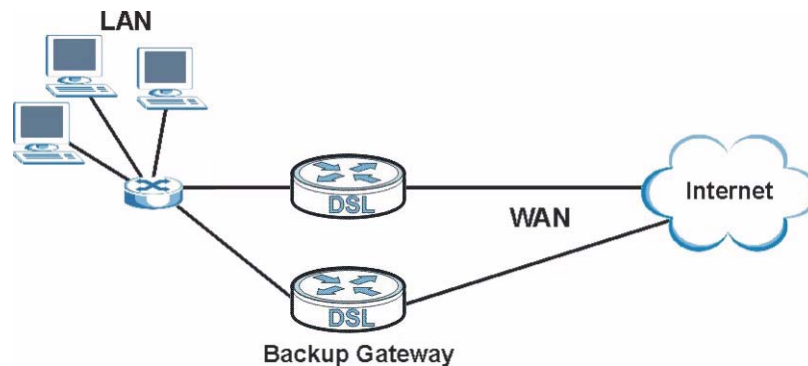

The following network topology allows you to avoid triangle route security issues when the backup gateway is connected to the LAN. Use IP alias to configure the LAN into two or three logical networks with the P-793H v2 itself as the gateway for each LAN network. Put the protected LAN in one subnet (Subnet 1 in the following figure) and the backup gateway in another subnet (Subnet 2). Configure filters

that allow packets from the protected LAN (Subnet 1) to the backup gateway (Subnet 2).

Figure 36 Traffic Redirect LAN Setup

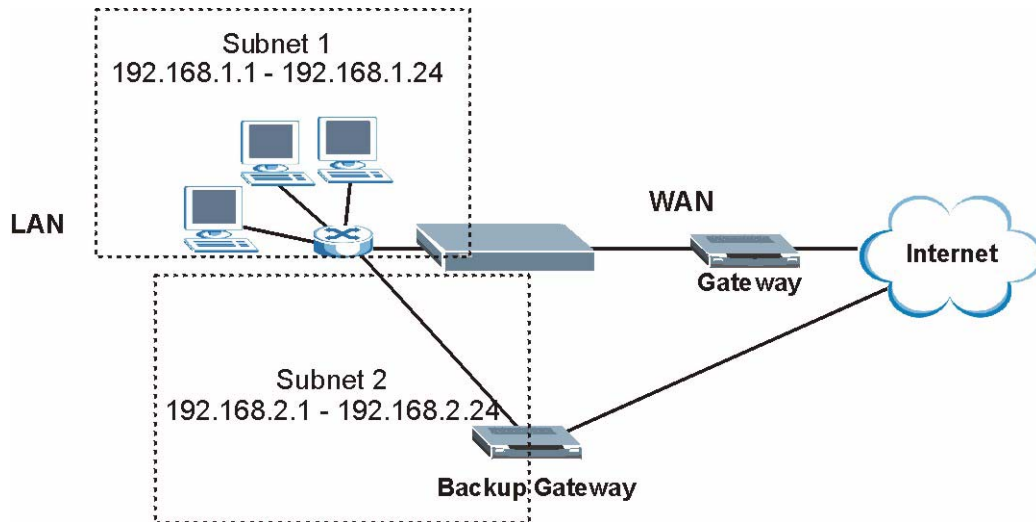

6.8 Traffic Shaping

Traffic Shaping is an agreement between the carrier and the subscriber to regulate the average rate and fluctuations of data transmission over an ATM network. This agreement helps eliminate congestion, which is important for transmission of real time data such as audio and video connections.

Peak Cell Rate (PCR) is the maximum rate at which the sender can send cells. This parameter may be lower (but not higher) than the maximum line speed. 1 ATM cell is 53 bytes (424 bits), so a maximum speed of 832Kbps gives a maximum PCR of 1962 cells/sec. This rate is not guaranteed because it is dependent on the line speed.

Sustained Cell Rate (SCR) is the mean cell rate of each bursty traffic source. It specifies the maximum average rate at which cells can be sent over the virtual connection. SCR may not be greater than the PCR.

Maximum Burst Size (MBS) is the maximum number of cells that can be sent at the PCR. After MBS is reached, cell rates fall below SCR until cell rate averages to the SCR again. At this time, more cells (up to the MBS) can be sent at the PCR again.

If the PCR, SCR or MBS is set to the default of "0", the system will assign a maximum value that correlates to your upstream line rate.

The following figure illustrates the relationship between PCR, SCR and MBS.

Figure 37 Example of Traffic Shaping

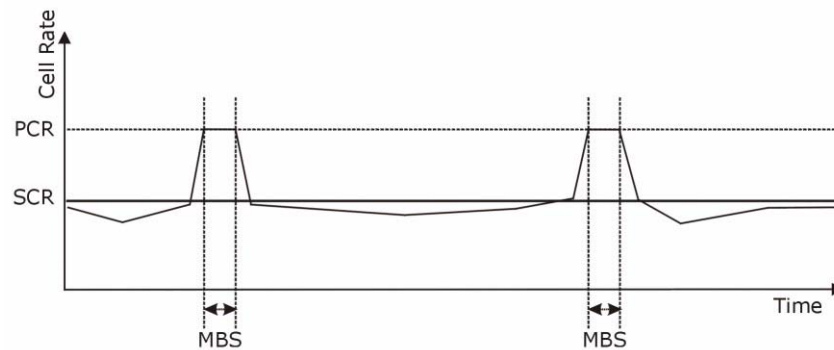

6.8.1 ATM Traffic Classes

These are the basic ATM traffic classes defined by the ATM Forum Traffic Management 4.0 Specification.

Constant Bit Rate (CBR)

Constant Bit Rate (CBR) provides fixed bandwidth that is always available even if no data is being sent. CBR traffic is generally time-sensitive (doesn't tolerate delay). CBR is used for connections that continuously require a specific amount of bandwidth. A PCR is specified and if traffic exceeds this rate, cells may be dropped. Examples of connections that need CBR would be high-resolution video and voice.

Variable Bit Rate (VBR)

The Variable Bit Rate (VBR) ATM traffic class is used with bursty connections. Connections that use the Variable Bit Rate (VBR) traffic class can be grouped into real time (VBR-RT) or non-real time (VBR-nRT) connections.

The VBR-RT (real-time Variable Bit Rate) type is used with bursty connections that require closely controlled delay and delay variation. It also provides a fixed amount of bandwidth (a PCR is specified) but is only available when data is being sent. An example of an VBR-RT connection would be video conferencing. Video conferencing requires real-time data transfers and the bandwidth requirement varies in proportion to the video image's changing dynamics.

The VBR-nRT (non real-time Variable Bit Rate) type is used with bursty connections that do not require closely controlled delay and delay variation. It is commonly used for "bursty" traffic typical on LANs. PCR and MBS define the burst

levels, SCR defines the minimum level. An example of an VBR-nRT connection would be non-time sensitive data file transfers.

Unspecified Bit Rate (UBR)

The Unspecified Bit Rate (UBR) ATM traffic class is for bursty data transfers. However, UBR doesn't guarantee any bandwidth and only delivers traffic when the network has spare bandwidth. An example application is background file transfer.

LAN Setup

7.1 Overview

A Local Area Network (LAN) is a shared communication system to which many networking devices are connected. It is usually located in one immediate area such as a building or floor of a building.

Use the LAN screens to help you configure a LAN DHCP server and manage IP addresses.

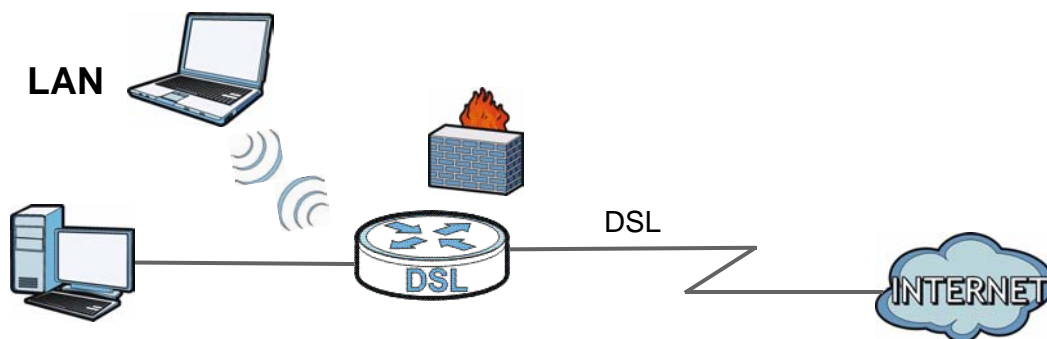

7.1.1 What You Can Do in the LAN Screens

- Use the **IP** screen ([Section 7.2 on page 103](#)) to set the LAN IP address and subnet mask of your ZyXEL device. You can also edit your P-793H v2's RIP, multicast, any IP and Windows Networking settings from this screen.
- Use the **DHCP Setup** screen ([Section 7.3 on page 106](#)) to configure the ZyXEL Device's DHCP settings.
- Use the **Client List** screen ([Section 7.4 on page 108](#)) to assign IP addresses on the LAN to specific individual computers based on their MAC Addresses.
- Use the **IP Alias** screen ([Section 7.5 on page 109](#)) to change your P-793H v2's IP alias settings.

7.1.2 What You Need To Know About LAN

IP Address

IP addresses identify individual devices on a network. Every networking device (including computers, servers, routers, printers, etc.) needs an IP address to communicate across the network. These networking devices are also known as hosts.

Subnet Mask

Subnet masks determine the maximum number of possible hosts on a network. You can also use subnet masks to divide one network into multiple sub-networks.

DHCP

A DHCP (Dynamic Host Configuration Protocol) server can assign your P-793H v2 an IP address, subnet mask, DNS and other routing information when it's turned on.

RIP

RIP (Routing Information Protocol) allows a router to exchange routing information with other routers.

Multicast

Traditionally, IP packets are transmitted in one of either two ways - Unicast (1 sender - 1 recipient) or Broadcast (1 sender - everybody on the network). Multicast delivers IP packets to a group of hosts on the network - not everybody and not just 1.

IGMP

IGMP (Internet Group Multicast Protocol) is a network-layer protocol used to establish membership in a Multicast group - it is not used to carry user data. There are three versions of IGMP. IGMP version 2 and 3 are improvements over version 1, but IGMP version 1 is still in wide use.

DNS

DNS (Domain Name System) is for mapping a domain name to its corresponding IP address and vice versa. The DNS server is extremely important because without it, you must know the IP address of a networking device before you can access it.

Finding Out More

See [Section 7.6 on page 111](#) for technical background information on LANs.

7.1.3 Before You Begin

Find out the MAC addresses of your network devices if you intend to add them to the DHCP Client List screen.

7.2 The IP Screen

Use this screen to set the Local Area Network IP address and subnet mask of your P-793H v2. Click **Network > LAN** to open the **IP** screen.

Follow these steps to configure your LAN settings.

- 1 Enter an IP address into the **IP Address** field. The IP address must be in dotted decimal notation. This will become the IP address of your P-793H v2.
- 2 Enter the IP subnet mask into the **IP Subnet Mask** field. Unless instructed otherwise it is best to leave this alone, the configurator will automatically compute a subnet mask based upon the IP address you entered.
- 3 Click **Apply** to save your settings.

Figure 38 Network > LAN > IP

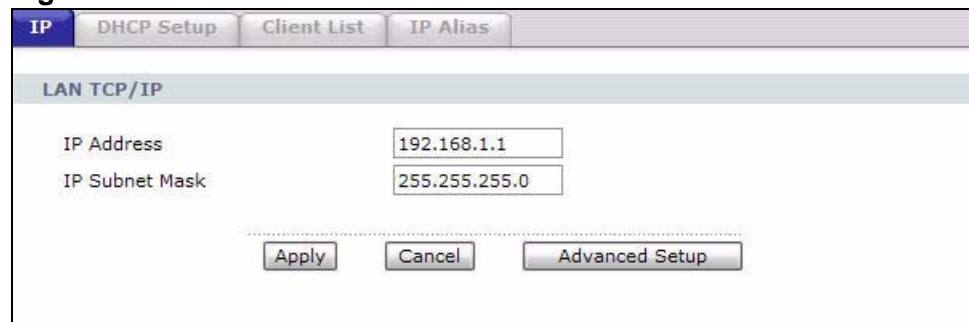

The screenshot shows a web-based configuration interface for the IP settings. At the top, there are four tabs: IP (selected), DHCP Setup, Client List, and IP Alias. Below the tabs is a section titled "LAN TCP/IP". Inside this section, there are two input fields: "IP Address" with the value "192.168.1.1" and "IP Subnet Mask" with the value "255.255.255.0". Below these fields are three buttons: "Apply", "Cancel", and "Advanced Setup".

The following table describes the fields in this screen.

Table 19 Network > LAN > IP

LABEL	DESCRIPTION
IP Address	Enter the LAN IP address you want to assign to your P-793H v2 in dotted decimal notation, for example, 192.168.1.1 (factory default).
IP Subnet Mask	Type the subnet mask of your network in dotted decimal notation, for example 255.255.255.0 (factory default). Your P-793H v2 automatically computes the subnet mask based on the IP Address you enter, so do not change this field unless you are instructed to do so.
Apply	Click this to save your changes.
Cancel	Click this to restore your previously saved settings.
Advanced Setup	Click this to display the Advanced LAN Setup screen and edit more details of your LAN setup.

7.2.1 The Advanced LAN IP Setup Screen

Use this screen to edit your P-793H v2's RIP, multicast, Any IP and Windows Networking settings. Click the **Advanced Setup** button in the **LAN IP** screen. The screen appears as shown.

Figure 39 Network > LAN > IP: Advanced Setup

The screenshot displays the 'Advanced Setup' screen for Network > LAN > IP. It is organized into several sections:

- RIP & Multicast Setup:**
 - RIP Direction: Both (dropdown)
 - RIP Version: RIP-1 (dropdown)
 - Multicast: None (dropdown)
- Any IP Setup:**
 - Active:
- Windows Networking (NetBIOS over TCP/IP):**
 - Allow between LAN and WAN:
- Packet Filter:**
 - Incoming Filter Sets:**
 - Protocol Filter: None (dropdown), None (dropdown), None (dropdown), None (dropdown)
 - Generic Filter: None (dropdown), None (dropdown), None (dropdown), None (dropdown)
 - Outgoing Filter Sets:**
 - Protocol Filter: None (dropdown), None (dropdown), None (dropdown), None (dropdown)
 - Generic Filter: None (dropdown), None (dropdown), None (dropdown), None (dropdown)

At the bottom of the screen, there are three buttons: Back, Apply, and Cancel.

The following table describes the labels in this screen.

Table 20 Network > LAN > IP: Advanced Setup

LABEL	DESCRIPTION
RIP & Multicast Setup	
RIP Direction	Select the RIP direction from None , Both , In Only and Out Only .
RIP Version	Select the RIP version from RIP-1 , RIP-2B and RIP-2M .
Multicast	IGMP (Internet Group Multicast Protocol) is a network-layer protocol used to establish membership in a multicast group. The P-793H v2 supports IGMP-v1 , IGMP-v2 and IGMP-v3 . Select None to disable it.
Any IP Setup	
Active	<p>Select the Active check box to enable the Any IP feature. This allows a computer to access the Internet via the P-793H v2 without changing the network settings (such as IP address and subnet mask) of the computer, even when the IP addresses of the computer and the P-793H v2 are not in the same subnet.</p> <p>When you disable the Any IP feature, only computers with dynamic IP addresses or static IP addresses in the same subnet as the P-793H v2's LAN IP address can connect to the P-793H v2 or access the Internet through the P-793H v2.</p> <p>Note: You must enable NAT/SUA in the NAT screen to use the Any IP feature on the P-793H v2</p>
Windows Networking (NetBIOS over TCP/IP)	NetBIOS (Network Basic Input/Output System) are TCP or UDP packets that enable a computer to connect to and communicate with a LAN. For some dial-up services such as PPPoE or PPTP, NetBIOS packets cause unwanted calls. However it may sometimes be necessary to allow NetBIOS packets to pass through to the WAN in order to find a computer on the WAN.
Allow between LAN and WAN	<p>Select this check box to forward NetBIOS packets from the LAN to the WAN and from the WAN to the LAN. If your firewall is enabled with the default policy set to block WAN to LAN traffic, you also need to enable the default WAN to LAN firewall rule that forwards NetBIOS traffic.</p> <p>Clear this check box to block all NetBIOS packets going from the LAN to the WAN and from the WAN to the LAN.</p>
Packet Filter	
Incoming Filter Sets	
Protocol Filter	<p>Select the protocol filter(s) to control incoming traffic. You may choose up to 4 sets of filters.</p> <p>You can configure packet filters in the Packet Filter screen. See Chapter 12 on page 217 for more details.</p>
Generic Filter	<p>Select the generic filter(s) to control incoming traffic. You may choose up to 4 sets of filters.</p> <p>You can configure generic filters in the Packet Filter screen. See Chapter 12 on page 217 for more details.</p>

Table 20 Network > LAN > IP: Advanced Setup

LABEL	DESCRIPTION
Outgoing Filter Sets	
Protocol Filter	Select the protocol filter(s) to control outgoing traffic. You may choose up to 4 sets of filters. You can configure protocol filters in the Packet Filter screen. See Chapter 12 on page 217 for more details.
Generic Filter	Select the generic filter(s) to control outgoing traffic. You may choose up to 4 sets of filters. You can configure generic filters in the Packet Filter screen. See Chapter 12 on page 217 for more details.
Back	Click this to return to the previous screen without saving.
Apply	Click this to save your changes.
Cancel	Click this to restore your previously saved settings.

7.3 The DHCP Setup Screen

Use this screen to configure the DNS server information that the P-793H v2 sends to the DHCP client devices on the LAN. Click **Network > DHCP Setup** to open this screen.

Figure 40 Network > LAN > DHCP Setup

The screenshot shows the DHCP Setup configuration page. It features a navigation bar with tabs for IP, DHCP Setup, Client List, and IP Alias. The main content area is divided into two sections: DHCP Setup and DNS Server. The DHCP Setup section includes a dropdown menu for 'DHCP' set to 'Server', and input fields for 'IP Pool Starting Address' (192.168.1.33), 'Pool Size' (32), and 'Remote DHCP Server' (0.0.0.0). The DNS Server section is titled 'DNS Servers Assigned by DHCP Server' and contains three rows for 'First DNS Server', 'Second DNS Server', and 'Third DNS Server'. Each row has a dropdown menu set to 'Obtained From ISP' and an input field containing '0.0.0.0'. At the bottom of the page are 'Apply' and 'Cancel' buttons.

The following table describes the labels in this screen.

Table 21 Network > LAN > DHCP Setup

LABEL	DESCRIPTION
DHCP Setup	
DHCP	<p>If set to Server, your P-793H v2 can assign IP addresses, an IP default gateway and DNS servers to Windows 95, Windows NT and other systems that support the DHCP client.</p> <p>If set to None, the DHCP server will be disabled.</p> <p>If set to Relay, the P-793H v2 acts as a surrogate DHCP server and relays DHCP requests and responses between the remote server and the clients. Enter the IP address of the actual, remote DHCP server in the Remote DHCP Server field in this case.</p> <p>When DHCP is used, the following items need to be set:</p>
IP Pool Starting Address	This field specifies the first of the contiguous addresses in the IP address pool.
Pool Size	This field specifies the size, or count of the IP address pool.
Remote DHCP Server	If Relay is selected in the DHCP field above then enter the IP address of the actual remote DHCP server here.
DNS Server	
DNS Servers Assigned by DHCP Server	The P-793H v2 passes a DNS (Domain Name System) server IP address to the DHCP clients.
First DNS Server Second DNS Server Third DNS Server	<p>Select Obtained From ISP if your ISP dynamically assigns DNS server information (and the P-793H v2's WAN IP address).</p> <p>Select UserDefined if you have the IP address of a DNS server. Enter the DNS server's IP address in the field to the right. If you chose UserDefined, but leave the IP address set to 0.0.0.0, UserDefined changes to None after you click Apply. If you set a second choice to UserDefined, and enter the same IP address, the second UserDefined changes to None after you click Apply.</p> <p>Select DNS Relay to have the P-793H v2 act as a DNS proxy only when the ISP uses IPCP DNS server extensions. The P-793H v2's LAN IP address displays in the field to the right (read-only). The P-793H v2 tells the DHCP clients on the LAN that the P-793H v2 itself is the DNS server. When a computer on the LAN sends a DNS query to the P-793H v2, the P-793H v2 forwards the query to the real DNS server learned through IPCP and relays the response back to the computer. You can only select DNS Relay for one of the three servers; if you select DNS Relay for a second or third DNS server, that choice changes to None after you click Apply.</p> <p>Select None if you do not want to configure DNS servers. You must have another DHCP sever on your LAN, or else the computers must have their DNS server addresses manually configured. If you do not configure a DNS server, you must know the IP address of a computer in order to access it.</p>
Apply	Click this to save your changes.
Cancel	Click this to restore your previously saved settings.

7.4 The Client List Screen

This table allows you to assign IP addresses on the LAN to specific individual computers based on their MAC Addresses.

Every Ethernet device has a unique MAC (Media Access Control) address. The MAC address is assigned at the factory and consists of six pairs of hexadecimal characters, for example, 00:A0:C5:00:00:02.

Use this screen to change your P-793H v2's static DHCP settings. Click **Network > LAN > Client List** to open the following screen.

Figure 41 Network > LAN > Client List

The following table describes the labels in this screen.

Table 22 Network > LAN > Client List

LABEL	DESCRIPTION
IP Address	Enter the IP address that you want to assign to the computer on your LAN with the MAC address that you will also specify.
MAC Address	Enter the MAC address of a computer on your LAN.
Add	Click this to add a static DHCP entry.
#	This is the index number of the static IP table entry (row).
Status	This field displays whether the client is connected to the P-793H v2.
Host Name	This field displays the computer host name.
IP Address	This field displays the IP address relative to the # field listed above.
MAC Address	The MAC (Media Access Control) or Ethernet address on a LAN (Local Area Network) is unique to your computer (six pairs of hexadecimal notation). A network interface card such as an Ethernet adapter has a hardwired address that is assigned at the factory. This address follows an industry standard that ensures no other adapter has a similar address.
Reserve	Select the check box in the heading row to automatically select all check boxes or select the check box(es) in each entry to have the P-793H v2 always assign the selected entry(ies)'s IP address(es) to the corresponding MAC address(es) (and host name(s)). You can select up to 10 entries in this table.

Table 22 Network > LAN > Client List

LABEL	DESCRIPTION
Modify	Click the modify icon to have the IP address field editable and change it.
Apply	Click this to save your changes.
Cancel	Click this to restore your previously saved settings.
Refresh	Click this to reload the DHCP table.

7.5 The IP Alias Screen

IP alias allows you to partition a physical network into different logical networks over the same Ethernet interface. The P-793H v2 supports three logical LAN interfaces via its single physical Ethernet interface with the P-793H v2 itself as the gateway for each LAN network.

When you use IP alias, you can also configure firewall rules to control access between the LAN's logical networks (subnets).

Note: Make sure that the subnets of the logical networks do not overlap.

The following figure shows a LAN divided into subnets A, B, and C.

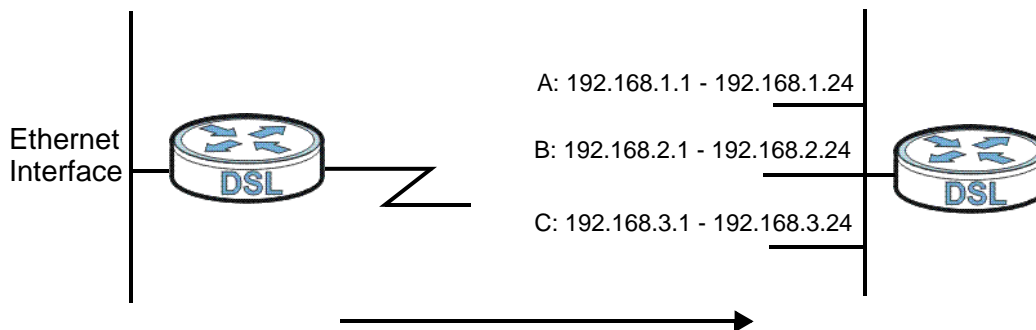
Figure 42 Physical Network & Partitioned Logical Networks

7.5.1 Configuring the LAN IP Alias Screen

Use this screen to change your P-793H v2's IP alias settings. Click **Network > LAN > IP Alias** to open the following screen.

Figure 43 Network > LAN > IP Alias

The screenshot shows the 'IP Alias' configuration screen. It features a navigation bar at the top with tabs for 'IP', 'DHCP Setup', 'Client List', and 'IP Alias'. Below the navigation bar, there are two sections for 'IP Alias 1' and 'IP Alias 2'. Each section contains a checkbox to enable the alias, followed by input fields for 'IP Address' and 'IP Subnet Mask', and dropdown menus for 'RIP Direction' and 'RIP Version'. At the bottom, there are 'Apply' and 'Cancel' buttons.

The following table describes the labels in this screen.

Table 23 Network > LAN > IP Alias

LABEL	DESCRIPTION
IP Alias 1, 2	Select the check box to configure another LAN network for the P-793H v2.
IP Address	Enter the IP address of your P-793H v2 in dotted decimal notation. Alternatively, click the right mouse button to copy and/or paste the IP address.
IP Subnet Mask	Your P-793H v2 will automatically calculate the subnet mask based on the IP address that you assign. Unless you are implementing subnetting, use the subnet mask computed by the P-793H v2.
RIP Direction	RIP (Routing Information Protocol, RFC 1058 and RFC 1389) allows a router to exchange routing information with other routers. The RIP Direction field controls the sending and receiving of RIP packets. Select the RIP direction from Both/In Only/Out Only/None . When set to Both or Out Only , the P-793H v2 will broadcast its routing table periodically. When set to Both or In Only , it will incorporate the RIP information that it receives; when set to None , it will not send any RIP packets and will ignore any RIP packets received.

Table 23 Network > LAN > IP Alias

LABEL	DESCRIPTION
RIP Version	The RIP Version field controls the format and the broadcasting method of the RIP packets that the P-793H v2 sends (it recognizes both formats when receiving). RIP-1 is universally supported but RIP-2 carries more information. RIP-1 is probably adequate for most networks, unless you have an unusual network topology. Both RIP-2B and RIP-2M sends the routing data in RIP-2 format; the difference being that RIP-2B uses subnet broadcasting while RIP-2M uses multicasting. Multicasting can reduce the load on non-router machines since they generally do not listen to the RIP multicast address and so will not receive the RIP packets. However, if one router uses multicasting, then all routers on your network must use multicasting, also. By default, RIP direction is set to Both and the Version set to RIP-1 .
Apply	Click this to save your changes.
Cancel	Click this to restore your previously saved settings.

7.6 LAN Technical Reference

This section provides some technical background information about the topics covered in this chapter.

7.6.1 LANs, WANs and the ZyXEL Device

The actual physical connection determines whether the P-793H v2 ports are LAN or WAN ports. There are two separate IP networks, one inside the LAN network and the other outside the WAN network as shown next.

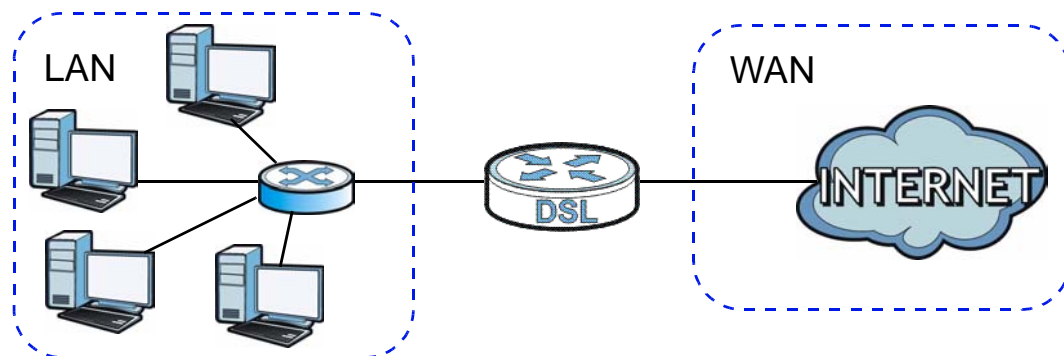
Figure 44 LAN and WAN IP Addresses

7.6.2 DHCP Setup

DHCP (Dynamic Host Configuration Protocol, RFC 2131 and RFC 2132) allows individual clients to obtain TCP/IP configuration at start-up from a server. You can configure the P-793H v2 as a DHCP server or disable it. When configured as a server, the P-793H v2 provides the TCP/IP configuration for the clients. If you turn DHCP service off, you must have another DHCP server on your LAN, or else the computer must be manually configured.

IP Pool Setup

The P-793H v2 is pre-configured with a pool of IP addresses for the DHCP clients (DHCP Pool). See the product specifications in the appendices. Do not assign static IP addresses from the DHCP pool to your LAN computers.

7.6.3 DNS Server Addresses

DNS (Domain Name System) maps a domain name to its corresponding IP address and vice versa. The DNS server is extremely important because without it, you must know the IP address of a computer before you can access it. The DNS server addresses you enter when you set up DHCP are passed to the client machines along with the assigned IP address and subnet mask.

There are two ways that an ISP disseminates the DNS server addresses.

- The ISP tells you the DNS server addresses, usually in the form of an information sheet, when you sign up. If your ISP gives you DNS server addresses, enter them in the **DNS Server** fields in the **DHCP Setup** screen.
- Some ISPs choose to disseminate the DNS server addresses using the DNS server extensions of IPCP (IP Control Protocol) after the connection is up. If your ISP did not give you explicit DNS servers, chances are the DNS servers are conveyed through IPCP negotiation. The P-793H v2 supports the IPCP DNS server extensions through the DNS proxy feature.

If the **DNS Server** fields in the **DHCP Setup** screen are set to **DNS Relay**, the P-793H v2 tells the DHCP clients that it itself is the DNS server. When a computer sends a DNS query to the P-793H v2, the P-793H v2 acts as a DNS proxy and forwards the query to the real DNS server learned through IPCP and relays the response back to the computer.

Please note that DNS proxy works only when the ISP uses the IPCP DNS server extensions. It does not mean you can leave the DNS servers out of the DHCP setup under all circumstances. If your ISP gives you explicit DNS servers, make sure that you enter their IP addresses in the **DHCP Setup** screen.

7.6.4 LAN TCP/IP

The P-793H v2 has built-in DHCP server capability that assigns IP addresses and DNS servers to systems that support DHCP client capability.

IP Address and Subnet Mask

Similar to the way houses on a street share a common street name, so too do computers on a LAN share one common network number.

Where you obtain your network number depends on your particular situation. If the ISP or your network administrator assigns you a block of registered IP addresses, follow their instructions in selecting the IP addresses and the subnet mask.

If the ISP did not explicitly give you an IP network number, then most likely you have a single user account and the ISP will assign you a dynamic IP address when the connection is established. If this is the case, it is recommended that you select a network number from 192.168.0.0 to 192.168.255.0 and you must enable the Network Address Translation (NAT) feature of the P-793H v2. The Internet Assigned Number Authority (IANA) reserved this block of addresses specifically for private use; please do not use any other number unless you are told otherwise. Let's say you select 192.168.1.0 as the network number; which covers 254 individual addresses, from 192.168.1.1 to 192.168.1.254 (zero and 255 are reserved). In other words, the first three numbers specify the network number while the last number identifies an individual computer on that network.

Once you have decided on the network number, pick an IP address that is easy to remember, for instance, 192.168.1.1, for your P-793H v2, but make sure that no other device on your network is using that IP address.

The subnet mask specifies the network number portion of an IP address. Your P-793H v2 will compute the subnet mask automatically based on the IP address that you entered. You don't need to change the subnet mask computed by the P-793H v2 unless you are instructed to do otherwise.

Private IP Addresses

Every machine on the Internet must have a unique address. If your networks are isolated from the Internet, for example, only between your two branch offices, you can assign any IP addresses to the hosts without problems. However, the Internet Assigned Numbers Authority (IANA) has reserved the following three blocks of IP addresses specifically for private networks:

- 10.0.0.0 — 10.255.255.255
- 172.16.0.0 — 172.31.255.255

- 192.168.0.0 — 192.168.255.255

You can obtain your IP address from the IANA, from an ISP or it can be assigned from a private network. If you belong to a small organization and your Internet access is through an ISP, the ISP can provide you with the Internet addresses for your local networks. On the other hand, if you are part of a much larger organization, you should consult your network administrator for the appropriate IP addresses.

Note: Regardless of your particular situation, do not create an arbitrary IP address; always follow the guidelines above. For more information on address assignment, please refer to RFC 1597, “Address Allocation for Private Internets” and RFC 1466, “Guidelines for Management of IP Address Space”.

7.6.5 RIP Setup

RIP (Routing Information Protocol) allows a router to exchange routing information with other routers. The **RIP Direction** field controls the sending and receiving of RIP packets. When set to:

- **Both** - the P-793H v2 will broadcast its routing table periodically and incorporate the RIP information that it receives.
- **In Only** - the P-793H v2 will not send any RIP packets but will accept all RIP packets received.
- **Out Only** - the P-793H v2 will send out RIP packets but will not accept any RIP packets received.
- **None** - the P-793H v2 will not send any RIP packets and will ignore any RIP packets received.

The **Version** field controls the format and the broadcasting method of the RIP packets that the P-793H v2 sends (it recognizes both formats when receiving). RIP-1 is universally supported; but RIP-2 carries more information. RIP-1 is probably adequate for most networks, unless you have an unusual network topology.

Both RIP-2B and RIP-2M sends the routing data in RIP-2 format; the difference being that RIP-2B uses subnet broadcasting while RIP-2M uses multicasting.

7.6.6 Multicast

Traditionally, IP packets are transmitted in one of either two ways - Unicast (1 sender - 1 recipient) or Broadcast (1 sender - everybody on the network). Multicast delivers IP packets to a group of hosts on the network - not everybody and not just 1.

IGMP (Internet Group Multicast Protocol) is a network-layer protocol used to establish membership in a Multicast group - it is not used to carry user data. IGMP version 2 (RFC 2236) is an improvement over version 1 (RFC 1112) but IGMP version 1 is still in wide use. IGMP version 3 supports source filtering, reporting or ignoring traffic from specific source address to a particular host on the network. If you would like to read more detailed information about interoperability between IGMP version 2 and version 1, please see sections 4 and 5 of RFC 2236. The class D IP address is used to identify host groups and can be in the range 224.0.0.0 to 239.255.255.255. The address 224.0.0.0 is not assigned to any group and is used by IP multicast computers. The address 224.0.0.1 is used for query messages and is assigned to the permanent group of all IP hosts (including gateways). All hosts must join the 224.0.0.1 group in order to participate in IGMP. The address 224.0.0.2 is assigned to the multicast routers group.

The P-793H v2 supports IGMP version 1 (**IGMP-v1**), IGMP version 2 (**IGMP-v2**) and IGMP version 3 (**IGMP-v3**). At start up, the P-793H v2 queries all directly connected networks to gather group membership. After that, the P-793H v2 periodically updates this information. IP multicasting can be enabled/disabled on the P-793H v2 LAN and/or WAN interfaces in the web configurator (**LAN**; **WAN**). Select **None** to disable IP multicasting on these interfaces.

Network Address Translation (NAT)

8.1 Overview

This chapter discusses how to configure NAT on the P-793H v2. NAT (Network Address Translation - NAT, RFC 1631) is the translation of the IP address of a host in a packet, for example, the source address of an outgoing packet, used within one network to a different IP address known within another network.

8.1.1 What You Can Do in the NAT Screens

- Use the **General** screen ([Section 8.2 on page 119](#)) to configure the NAT setup settings.
- Use the **Port Forwarding** screen ([Section 8.3 on page 120](#)) to configure forward incoming service requests to the server(s) on your local network.
- Use the **Address Mapping** screen ([Section 8.4 on page 123](#)) to change your P-793H v2's address mapping settings.
- Use the **ALG** screen ([Section 8.5 on page 127](#)) to enable and disable the SIP (VoIP) ALG in the P-793H v2.

8.1.2 What You Need To Know About NAT

Inside/Outside

Inside/outside denotes where a host is located relative to the P-793H v2, for example, the computers of your subscribers are the inside hosts, while the web servers on the Internet are the outside hosts.

Global/Local

Global/local denotes the IP address of a host in a packet as the packet traverses a router, for example, the local address refers to the IP address of a host when the packet is in the local network, while the global address refers to the IP address of the host when the same packet is traveling in the WAN side.

NAT

In the simplest form, NAT changes the source IP address in a packet received from a subscriber (the inside local address) to another (the inside global address) before forwarding the packet to the WAN side. When the response comes back, NAT translates the destination address (the inside global address) back to the inside local address before forwarding it to the original inside host.

Port Forwarding

A port forwarding set is a list of inside (behind NAT on the LAN) servers, for example, web or FTP, that you can make visible to the outside world even though NAT makes your whole inside network appear as a single computer to the outside world.

SUA (Single User Account) Versus NAT

SUA (Single User Account) is a ZyNOS implementation of a subset of NAT that supports two types of mapping, **Many-to-One** and **Server**. The P-793H v2 also supports **Full Feature** NAT to map multiple global IP addresses to multiple private LAN IP addresses of clients or servers using mapping types as outlined in [Table 31 on page 131](#).

- Choose **SUA Only** if you have just one public WAN IP address for your P-793H v2.
- Choose **Full Feature** if you have multiple public WAN IP addresses for your P-793H v2.

Finding Out More

See [Section 8.6 on page 127](#) for advanced technical information on NAT.

8.2 The NAT General Setup Screen

Use this screen to activate NAT. Click **Network > NAT** to open the following screen.

Note: You must create a firewall rule in addition to setting up SUA/NAT, to allow traffic from the WAN to be forwarded through the P-793H v2.

Figure 45 Network > NAT > General

The following table describes the labels in this screen.

Table 24 Network > NAT > General

LABEL	DESCRIPTION
Active Network Address Translation (NAT)	Select this check box to enable NAT.
SUA Only	Select this radio button if you have just one public WAN IP address for your P-793H v2.
Full Feature	Select this radio button if you have multiple public WAN IP addresses for your P-793H v2.
Max NAT/Firewall Session Per User	<p>When computers use peer to peer applications, such as file sharing applications, they need to establish NAT sessions. If you do not limit the number of NAT sessions a single client can establish, this can result in all of the available NAT sessions being used. In this case, no additional NAT sessions can be established, and users may not be able to access the Internet.</p> <p>Each NAT session establishes a corresponding firewall session. Use this field to limit the number of NAT/Firewall sessions client computers can establish through the P-793H v2.</p> <p>If your network has a small number of clients using peer to peer applications, you can raise this number to ensure that their performance is not degraded by the number of NAT sessions they can establish. If your network has a large number of users using peer to peer applications, you can lower this number to ensure no single client is exhausting all of the available NAT sessions.</p>
Apply	Click this to save your changes.
Cancel	Click this to restore your previously saved settings.

8.3 The Port Forwarding Screen

Note: This screen is available only when you select **SUA only** in the **NAT > General** screen.

Use this screen to forward incoming service requests to the server(s) on your local network.

You may enter a single port number or a range of port numbers to be forwarded, and the local IP address of the desired server. The port number identifies a service; for example, web service is on port 80 and FTP on port 21. In some cases, such as for unknown services or where one server can support more than one service (for example both FTP and web service), it might be better to specify a range of port numbers. You can allocate a server IP address that corresponds to a port or a range of ports.

The most often used port numbers and services are shown in [Appendix F on page 473](#). Please refer to RFC 1700 for further information about port numbers.

Note: Many residential broadband ISP accounts do not allow you to run any server processes (such as a Web or FTP server) from your location. Your ISP may periodically check for servers and may suspend your account if it discovers any active services at your location. If you are unsure, refer to your ISP.

Default Server IP Address

In addition to the servers for specified services, NAT supports a default server IP address. A default server receives packets from ports that are not specified in this screen.

Note: If you do not assign a **Default Server** IP address, the P-793H v2 discards all packets received for ports that are not specified here or in the remote management setup.

Configuring Servers Behind Port Forwarding (Example)

Let's say you want to assign ports 21-25 to one FTP, Telnet and SMTP server (**A** in the example), port 80 to another (**B** in the example) and assign a default server IP address of 192.168.1.35 to a third (**C** in the example). You assign the LAN IP addresses and the ISP assigns the WAN IP address. The NAT network appears as a single host on the Internet.

Figure 46 Multiple Servers Behind NAT Example

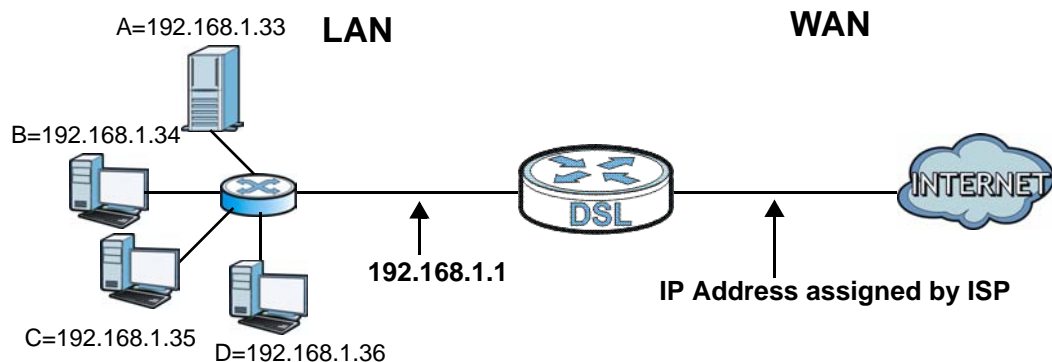

8.3.1 Configuring the Port Forwarding Screen

Click **Network > NAT > Port Forwarding** to open the following screen.

See [Appendix F on page 473](#) for port numbers commonly used for particular services.

Figure 47 Network > NAT > Port Forwarding

The screenshot shows a web-based configuration interface. At the top, there are three tabs: 'General', 'Port Forwarding' (selected), and 'ALG'. Below the tabs is a 'Default Server Setup' section with a 'Default Server' text box containing '0.0.0.0'. Underneath is a 'Port Forwarding' section. It features a 'Service Name' dropdown menu set to 'WWW' and a 'Server IP Address' text box set to '0.0.0.0', with an 'Add' button to the right. Below this is a table with the following data:

#	Active	Service Name	Start Port	End Port	Server IP Address	Modify
1	<input checked="" type="checkbox"/>	WWW	80	80	192.168.1.2	

At the bottom of the screen are 'Apply' and 'Cancel' buttons.

The following table describes the fields in this screen.

Table 25 Network > NAT > Port Forwarding

LABEL	DESCRIPTION
Default Server Setup	
Default Server	In addition to the servers for specified services, NAT supports a default server. A default server receives packets from ports that are not specified in this screen. If you do not assign a Default Server IP address, the P-793H v2 discards all packets received for ports that are not specified here or in the remote management setup.
Port Forwarding	
Service Name	Select a service from the drop-down list box.
Server IP Address	Enter the IP address of the server for the specified service.
Add	Click this button to add a rule to the table below.
#	This is the rule index number (read-only).
Active	This field indicates whether the rule is active or not. Clear the check box to disable the rule. Select the check box to enable it.
Service Name	This is a service's name.
Start Port	This is the first port number that identifies a service.
End Port	This is the last port number that identifies a service.
Server IP Address	This is the server's IP address.
Modify	Click the edit icon to go to the screen where you can edit the port forwarding rule. Click the delete icon to delete an existing port forwarding rule. Note that subsequent address mapping rules move up by one when you take this action.
Apply	Click this to save your changes.
Cancel	Click this to restore your previously saved settings.

8.3.2 The Port Forwarding Rule Edit Screen

Use this screen to edit a port forwarding rule. Click the rule's edit icon in the **Port Forwarding** screen to display the screen shown next.

Figure 48 Network > NAT > Port Forwarding: Edit

The following table describes the fields in this screen.

Table 26 Network > NAT > Port Forwarding: Edit

LABEL	DESCRIPTION
Active	Click this check box to enable the rule.
Service Name	Enter a name to identify this port-forwarding rule.
Start Port	Enter a port number in this field. To forward only one port, enter the port number again in the End Port field. To forward a series of ports, enter the start port number here and the end port number in the End Port field.
End Port	Enter a port number in this field. To forward only one port, enter the port number again in the Start Port field above and then enter it again in this field. To forward a series of ports, enter the last port number in a series that begins with the port number in the Start Port field above.
Server IP Address	Enter the inside IP address of the server here.
Back	Click this to return to the previous screen without saving.
Apply	Click this to save your changes.
Cancel	Click this to restore your previously saved settings.

8.4 The Address Mapping Screen

Note: The **Address Mapping** screen is available only when you select **Full Feature** in the **NAT > General** screen.

Ordering your rules is important because the P-793H v2 applies the rules in the order that you specify. When a rule matches the current packet, the P-793H v2 takes the corresponding action and the remaining rules are ignored. If there are any empty rules before your new configured rule, your configured rule will be pushed up by that number of empty rules. For example, if you have already configured rules 1 to 6 in your current set and now you configure rule number 9. In the set summary screen, the new rule will be rule 7, not 9. Now if you delete rule 4, rules 5 to 7 will be pushed up by 1 rule, so old rules 5, 6 and 7 become new rules 4, 5 and 6.

To change your P-793H v2's address mapping settings, click **Network > NAT > Address Mapping** to open the following screen.

Figure 49 Network > NAT > Address Mapping

#	Local Start IP	Local End IP	Global Start IP	Global End IP	Type	Modify
1	-	-	-	-	-	
2	-	-	-	-	-	
3	-	-	-	-	-	
4	-	-	-	-	-	
5	-	-	-	-	-	
6	-	-	-	-	-	
7	-	-	-	-	-	
8	-	-	-	-	-	
9	-	-	-	-	-	
10	-	-	-	-	-	

The following table describes the fields in this screen.

Table 27 Network > NAT > Address Mapping

LABEL	DESCRIPTION
#	This is the rule index number.
Local Start IP	This is the starting Inside Local IP Address (ILA). Local IP addresses are N/A for Server port mapping.
Local End IP	This is the end Inside Local IP Address (ILA). If the rule is for all local IP addresses, then this field displays 0.0.0.0 as the Local Start IP address and 255.255.255.255 as the Local End IP address. This field is N/A for One-to-one and Server mapping types.
Global Start IP	This is the starting Inside Global IP Address (IGA). Enter 0.0.0.0 here if you have a dynamic IP address from your ISP. You can only do this for Many-to-One and Server mapping types.
Global End IP	This is the ending Inside Global IP Address (IGA). This field is N/A for One-to-one , Many-to-One and Server mapping types.

Table 27 Network > NAT > Address Mapping (continued)

LABEL	DESCRIPTION
Type	<p>1-1: One-to-one mode maps one local IP address to one global IP address. Note that port numbers do not change for the One-to-one NAT mapping type.</p> <p>M-1: Many-to-One mode maps multiple local IP addresses to one global IP address. This is equivalent to SUA (i.e., PAT, port address translation), ZyXEL's Single User Account feature that previous ZyXEL routers supported only.</p> <p>M-M Ov (Overload): Many-to-Many Overload mode maps multiple local IP addresses to shared global IP addresses.</p> <p>MM No (No Overload): Many-to-Many No Overload mode maps each local IP address to unique global IP addresses.</p> <p>Server: This type allows you to specify inside servers of different services behind the NAT to be accessible to the outside world.</p>
Modify	<p>Click the edit icon to go to the screen where you can edit the address mapping rule.</p> <p>Click the delete icon to delete an existing address mapping rule. Note that subsequent address mapping rules move up by one when you take this action.</p>

8.4.1 The Address Mapping Rule Edit Screen

Use this screen to edit an address mapping rule. Click the rule's edit icon in the **Address Mapping** screen to display the screen shown next.

Figure 50 Network > NAT > Address Mapping: Edit

Edit Address Mapping Rule1

Type: One-to-One

Local Start IP: 0.0.0.0

Local End IP: N/A

Global Start IP: 0.0.0.0

Global End IP: N/A

Server Mapping Set: 2 [Edit Details](#)

Back Apply Cancel

The following table describes the fields in this screen.

Table 28 Network > NAT > Address Mapping: Edit

LABEL	DESCRIPTION
Type	<p>Choose the port mapping type from one of the following.</p> <p>One-to-One: One-to-One mode maps one local IP address to one global IP address. Note that port numbers do not change for One-to-one NAT mapping type.</p> <p>Many-to-One: Many-to-One mode maps multiple local IP addresses to one global IP address. This is equivalent to SUA (i.e., PAT, port address translation), ZyXEL's Single User Account feature that previous ZyXEL routers supported only.</p> <p>Many-to-Many Overload: Many-to-Many Overload mode maps multiple local IP addresses to shared global IP addresses.</p> <p>Many-to-Many No Overload: Many-to-Many No Overload mode maps each local IP address to unique global IP addresses.</p> <p>Server: This type allows you to specify inside servers of different services behind the NAT to be accessible to the outside world.</p>
Local Start IP	This is the starting local IP address (ILA). Local IP addresses are N/A for Server port mapping.
Local End IP	<p>This is the end local IP address (ILA). If your rule is for all local IP addresses, then enter 0.0.0.0 as the Local Start IP address and 255.255.255.255 as the Local End IP address.</p> <p>This field is N/A for One-to-One and Server mapping types.</p>
Global Start IP	This is the starting global IP address (IGA). Enter 0.0.0.0 here if you have a dynamic IP address from your ISP.
Global End IP	This is the ending global IP address (IGA). This field is N/A for One-to-One , Many-to-One and Server mapping types.
Server Mapping Set	<p>Only available when Type is set to Server.</p> <p>Select a number from the drop-down menu to choose a port forwarding set.</p>
Edit Details	Click this link to go to the Port Forwarding screen to edit a port forwarding set that you have selected in the Server Mapping Set field.
Back	Click this to return to the previous screen without saving.
Apply	Click this to save your changes.
Cancel	Click this to restore your previously saved settings.

8.5 The ALG Screen

Some NAT routers may include a SIP Application Layer Gateway (ALG). A SIP ALG allows SIP calls to pass through NAT by examining and translating IP addresses embedded in the data stream. When the P-793H v2 registers with the SIP register server, the SIP ALG translates the P-793H v2's private IP address inside the SIP data stream to a public IP address. You do not need to use STUN or an outbound proxy if your P-793H v2 is behind a SIP ALG.

Use this screen to enable and disable the SIP (VoIP) ALG in the P-793H v2. To access this screen, click **Network > NAT > ALG**.

Figure 51 Network > NAT > ALG



The following table describes the fields in this screen.

Table 29 Network > NAT > ALG

LABEL	DESCRIPTION
Enable SIP ALG	Select this to change the private ports or IP in SIP messages so that the VoIP client behind the P-793H v2 can be found in RTP traffic.
Apply	Click this to save your changes.
Reset	Click this to restore your previously saved settings.

8.6 NAT Technical Reference

This chapter contains more information regarding NAT.

8.6.1 NAT Definitions

Inside/outside denotes where a host is located relative to the P-793H v2, for example, the computers of your subscribers are the inside hosts, while the web servers on the Internet are the outside hosts.

Global/local denotes the IP address of a host in a packet as the packet traverses a router, for example, the local address refers to the IP address of a host when the

packet is in the local network, while the global address refers to the IP address of the host when the same packet is traveling in the WAN side.

Note that inside/outside refers to the location of a host, while global/local refers to the IP address of a host used in a packet. Thus, an inside local address (ILA) is the IP address of an inside host in a packet when the packet is still in the local network, while an inside global address (IGA) is the IP address of the same inside host when the packet is on the WAN side. The following table summarizes this information.

Table 30 NAT Definitions

ITEM	DESCRIPTION
Inside	This refers to the host on the LAN.
Outside	This refers to the host on the WAN.
Local	This refers to the packet address (source or destination) as the packet travels on the LAN.
Global	This refers to the packet address (source or destination) as the packet travels on the WAN.

NAT never changes the IP address (either local or global) of an outside host.

8.6.2 What NAT Does

In the simplest form, NAT changes the source IP address in a packet received from a subscriber (the inside local address) to another (the inside global address) before forwarding the packet to the WAN side. When the response comes back, NAT translates the destination address (the inside global address) back to the inside local address before forwarding it to the original inside host. Note that the IP address (either local or global) of an outside host is never changed.

The global IP addresses for the inside hosts can be either static or dynamically assigned by the ISP. In addition, you can designate servers, for example, a web server and a telnet server, on your local network and make them accessible to the outside world. If you do not define any servers (for Many-to-One and Many-to-Many Overload mapping – see [Table 31 on page 131](#)), NAT offers the additional benefit of firewall protection. With no servers defined, your P-793H v2 filters out all incoming inquiries, thus preventing intruders from probing your network. For more information on IP address translation, refer to *RFC 1631, The IP Network Address Translator (NAT)*.

8.6.3 How NAT Works

Each packet has two addresses – a source address and a destination address. For outgoing packets, the ILA (Inside Local Address) is the source address on the LAN, and the IGA (Inside Global Address) is the source address on the WAN. For incoming packets, the ILA is the destination address on the LAN, and the IGA is the destination address on the WAN. NAT maps private (local) IP addresses to globally unique ones required for communication with hosts on other networks. It replaces the original IP source address (and TCP or UDP source port numbers for Many-to-One and Many-to-Many Overload NAT mapping) in each packet and then forwards it to the Internet. The P-793H v2 keeps track of the original addresses and port numbers so incoming reply packets can have their original values restored. The following figure illustrates this.

Figure 52 How NAT Works

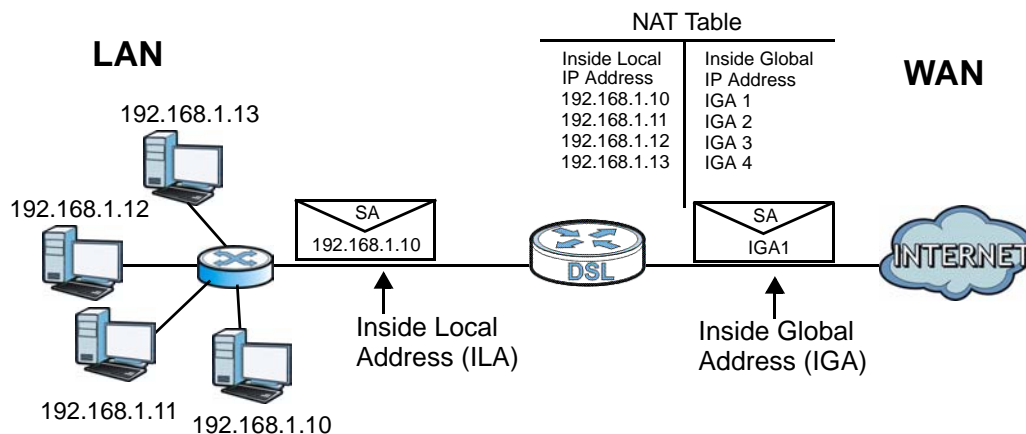

8.6.4 NAT Application

The following figure illustrates a possible NAT application, where three inside LANs (logical LANs using IP alias) behind the P-793H v2 can communicate with three distinct WAN networks.

Figure 53 NAT Application With IP Alias

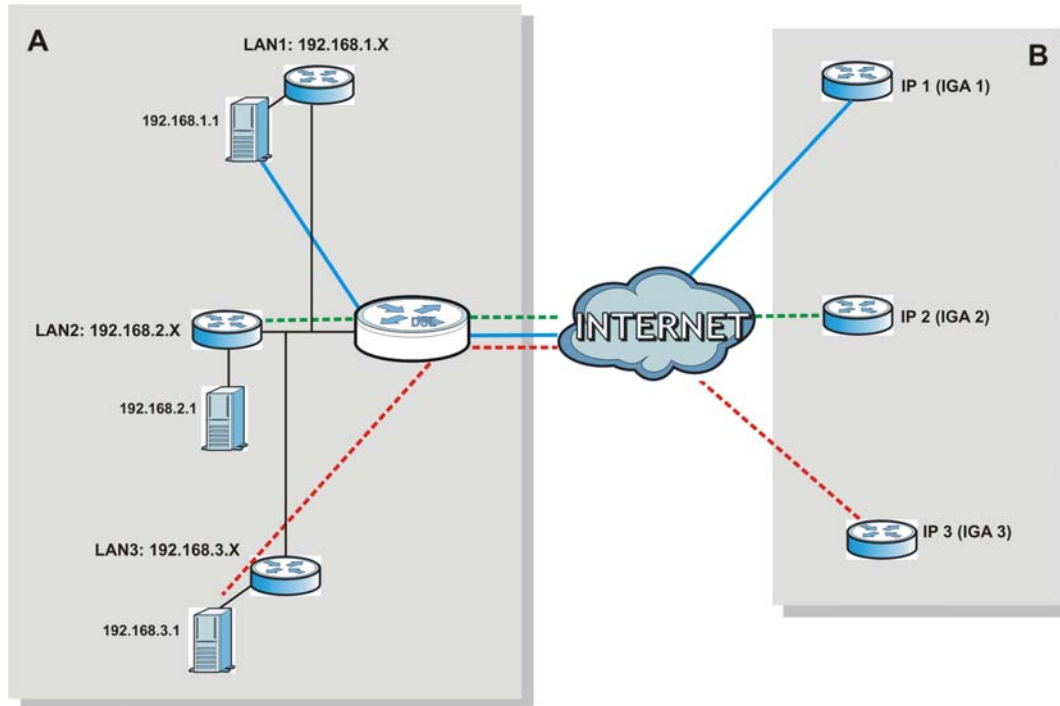

8.6.5 NAT Mapping Types

NAT supports five types of IP/port mapping. They are:

- **One to One:** In One-to-One mode, the P-793H v2 maps one local IP address to one global IP address.
- **Many to One:** In Many-to-One mode, the P-793H v2 maps multiple local IP addresses to one global IP address. This is equivalent to SUA (for instance, PAT, port address translation), ZyXEL's Single User Account feature that previous ZyXEL routers supported (the **SUA Only** option in today's routers).
- **Many to Many Overload:** In Many-to-Many Overload mode, the P-793H v2 maps the multiple local IP addresses to shared global IP addresses.
- **Many-to-Many No Overload:** In Many-to-Many No Overload mode, the P-793H v2 maps each local IP address to a unique global IP address.
- **Server:** This type allows you to specify inside servers of different services behind the NAT to be accessible to the outside world.

Port numbers do NOT change for **One-to-One** and **Many-to-Many No Overload** NAT mapping types.

The following table summarizes these types.

Table 31 NAT Mapping Types

TYPE	IP MAPPING
One-to-One	ILA1 ↔ IGA1
Many-to-One (SUA/PAT)	ILA1 ↔ IGA1 ILA2 ↔ IGA1 ...
Many-to-Many Overload	ILA1 ↔ IGA1 ILA2 ↔ IGA2 ILA3 ↔ IGA1 ILA4 ↔ IGA2 ...
Many-to-Many No Overload	ILA1 ↔ IGA1 ILA2 ↔ IGA2 ILA3 ↔ IGA3 ...
Server	Server 1 IP ↔ IGA1 Server 2 IP ↔ IGA1 Server 3 IP ↔ IGA1

Firewalls

9.1 Overview

This chapter shows you how to enable and configure the P-793H v2 firewall. Use these screens to enable and configure the firewall that protects your P-793H v2 and network from attacks by hackers on the Internet and control access to it. By default the firewall:

- allows traffic that originates from your LAN computers to go to all other networks.
- blocks traffic that originates on other networks from going to the LAN.

The following figure illustrates the default firewall action. User **A** can initiate an IM (Instant Messaging) session from the LAN to the WAN (1). Return traffic for this session is also allowed (2). However other traffic initiated from the WAN is blocked (3 and 4).

Figure 54 Default Firewall Action

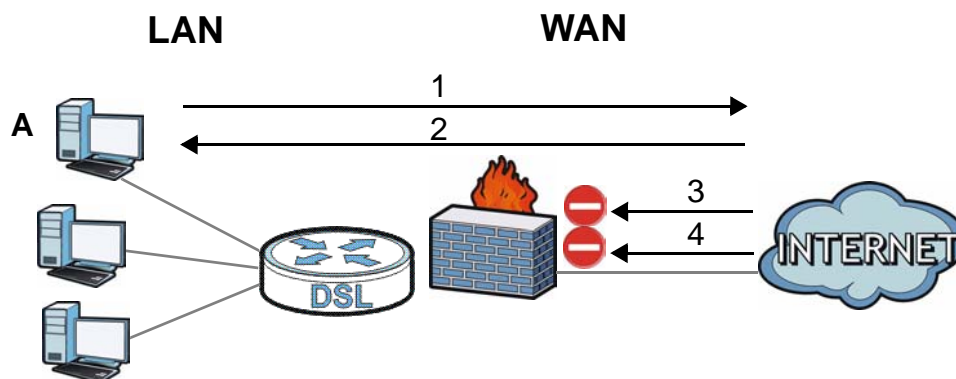

9.1.1 What You Can Do in the Firewall Screens

- Use the **General** screen ([Section 9.2 on page 138](#)) to enable firewall and/or triangle route on the P-793H v2, and set the default action that the firewall takes on packets that do not match any of the firewall rules.
- Use the **Rules** screen ([Section 9.3 on page 140](#)) to view the configured firewall rules and add, edit or remove a firewall rule.

- Use the **Threshold** screen ([Section 9.4 on page 145](#)) to set the thresholds that the P-793H v2 uses to determine when to start dropping sessions that do not become fully established (half-open sessions).

9.1.2 What You Need to Know About Firewall

DoS

Denials of Service (DoS) attacks are aimed at devices and networks with a connection to the Internet. Their goal is not to steal information, but to disable a device or network so users no longer have access to network resources. The ZyXEL Device is pre-configured to automatically detect and thwart all known DoS attacks.

Anti-Probing

If an outside user attempts to probe an unsupported port on your P-793H v2, an ICMP response packet is automatically returned. This allows the outside user to know the P-793H v2 exists. The P-793H v2 supports anti-probing, which prevents the ICMP response packet from being sent. This keeps outsiders from discovering your P-793H v2 when unsupported ports are probed.

ICMP

Internet Control Message Protocol (ICMP) is a message control and error-reporting protocol between a host server and a gateway to the Internet. ICMP uses Internet Protocol (IP) datagrams, but the messages are processed by the TCP/IP software and directly apparent to the application user.

DoS Thresholds

For DoS attacks, the P-793H v2 uses thresholds to determine when to drop sessions that do not become fully established. These thresholds apply globally to all sessions. You can use the default threshold values, or you can change them to values more suitable to your security requirements.

Finding Out More

- See [Section 9.1.3 on page 135](#) for an example of setting up a firewall.
- See [Section 9.5 on page 149](#) for advanced technical information on firewall.

9.1.3 Firewall Rule Setup Example

The following Internet firewall rule example allows a hypothetical “MyService” connection from the Internet.

- 1 Click **Security > Firewall > Rules**.
- 2 Select **WAN to LAN** in the **Packet Direction** field.

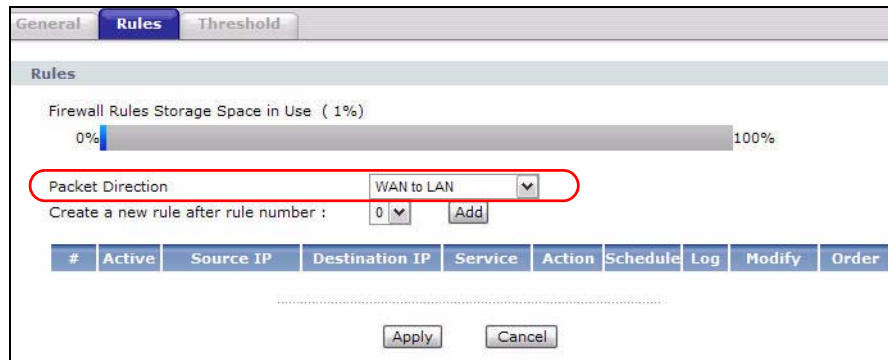

- 3 In the **Rules** screen, select the index number after that you want to add the rule. For example, if you select “6”, your new rule becomes number 7 and the previous rule 7 (if there is one) becomes rule 8.
- 4 Click **Add** to display the firewall rule configuration screen.
- 5 In the **Edit Rule** screen, click the **Edit Customized Services** link to open the **Customized Service** screen.
- 6 Click an index number to display the **Customized Services Config** screen and configure the screen as follows and click **Apply**.

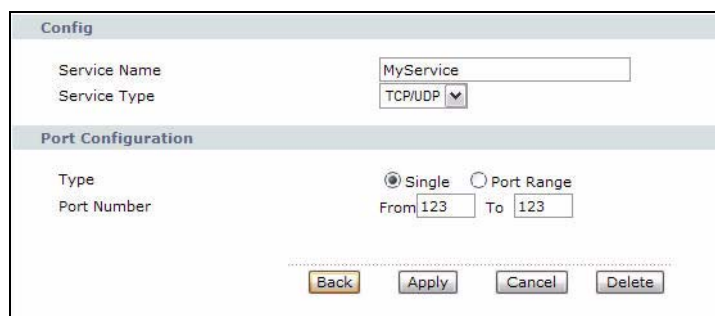

- 7 Select **Any** in the **Destination Address List** box and then click **Delete**.

- 8 Configure the destination address screen as follows and click **Add**.

The screenshot shows the 'Edit Rule 1' configuration interface. At the top, there is a checkbox for 'Active' which is checked, and a dropdown menu for 'Action for Matched Packets' set to 'Permit'. Below this are two sections: 'Source Address' and 'Destination Address'. The 'Source Address' section has an 'Address Type' dropdown set to 'Any Address', and input fields for 'Start IP Address' (0.0.0.0), 'End IP Address' (0.0.0.0), and 'Subnet Mask' (0.0.0.0). To the right of these fields are buttons for 'Add >>', 'Edit <<', and 'Delete'. The 'Destination Address List' on the right contains the text 'Any'. The 'Destination Address' section has an 'Address Type' dropdown set to 'Range Address', and input fields for 'Start IP Address' (10.0.0.10) and 'End IP Address' (10.0.0.15), with 'Subnet Mask' (0.0.0.0) below. The 'Add >>' button is circled in red. The 'Destination Address List' on the right contains the text 'Any'.

- 9 Use the **Add >>** and **Remove** buttons between **Available Services** and **Selected Services** list boxes to configure it as follows. Click **Apply** when you are done.

Note: Custom services show up with an “*” before their names in the **Services** list box and the **Rules** list box.

Edit Rule 1

Active
Action for Matched Packets: Permit

Source Address

Address Type: Any Address
Start IP Address: 0.0.0.0
End IP Address: 0.0.0.0
Subnet Mask: 0.0.0.0
Source Address List: Any

Destination Address

Address Type: Range Address
Start IP Address: 10.0.0.10
End IP Address: 10.0.0.15
Subnet Mask: 0.0.0.0
Destination Address List: 10.0.0.10 - 10.0.0.15

Service

Available Services: Any(All), Any(ICMP), *AM/NEW-ICQ(TCP:5190), *AUTH(TCP:113), *BGP(TCP:179)
Selected Services: *MyService(TCP/UDP:123)

Schedule

Day to Apply: Everyday
 Sun Mon Tue Wed Thu Fri Sat
Time of Day to Apply : (24-Hour Format)
 All day
Start 0 hour 0 minute End 0 hour 0 minute

Log: Log Packet Detail Information.

Alert: Send Alert Message to Administrator When Matched.

Back Apply Cancel

On completing the configuration procedure for this Internet firewall rule, the **Rules** screen should look like the following.

Rule 1 allows a “MyService” connection from the WAN to IP addresses 10.0.0.10 through 10.0.0.15 on the LAN.

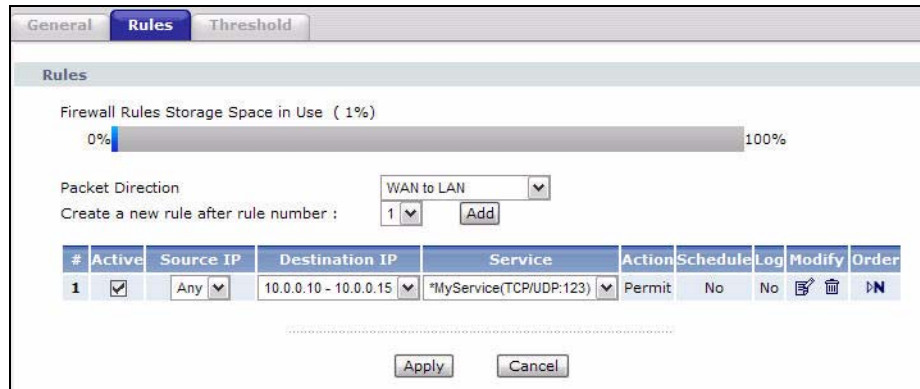

9.2 The Firewall General Screen

Use this screen to configure the firewall settings. Click **Security > Firewall** to display the following screen.

Figure 55 Security > Firewall > General

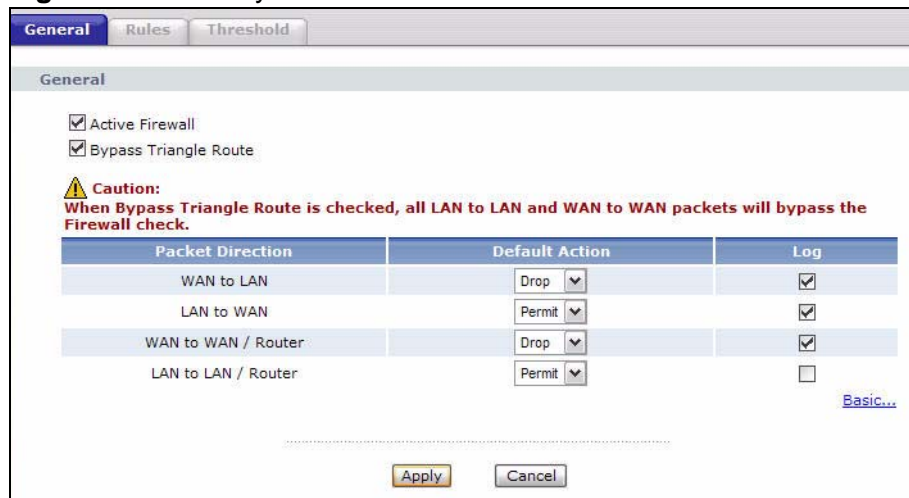

The following table describes the labels in this screen.

Table 32 Security > Firewall > General

LABEL	DESCRIPTION
Active Firewall	Select this check box to activate the firewall. The P-793H v2 performs access control and protects against Denial of Service (DoS) attacks when the firewall is activated.
Bypass Triangle Route	<p>If an alternate gateway on the LAN has an IP address in the same subnet as the P-793H v2's LAN IP address, return traffic may not go through the P-793H v2. This is called an asymmetrical or "triangle" route. This causes the P-793H v2 to reset the connection, as the connection has not been acknowledged.</p> <p>Select this check box to have the P-793H v2 permit the use of asymmetrical route topology on the network (not reset the connection).</p> <p>Note: Allowing asymmetrical routes may let traffic from the WAN go directly to the LAN without passing through the P-793H v2. A better solution is to use IP alias to put the P-793H v2 and the backup gateway on separate subnets. See Section 9.5.4.1 on page 152 for an example.</p>
Packet Direction	<p>This is the direction of travel of packets (LAN to LAN / Router, LAN to WAN, WAN to WAN / Router, WAN to LAN).</p> <p>Firewall rules are grouped based on the direction of travel of packets to which they apply. For example, LAN to LAN / Router means packets traveling from a computer/subnet on the LAN to either another computer/subnet on the LAN interface of the P-793H v2 or the P-793H v2 itself.</p>
Default Action	<p>Use the drop-down list boxes to select the default action that the firewall is to take on packets that are traveling in the selected direction and do not match any of the firewall rules.</p> <p>Select Drop to silently discard the packets without sending a TCP reset packet or an ICMP destination-unreachable message to the sender.</p> <p>Select Reject to deny the packets and send a TCP reset packet (for a TCP packet) or an ICMP destination-unreachable message (for a UDP packet) to the sender.</p> <p>Select Permit to allow the passage of the packets.</p>
Log	Select the check box to create a log (when the above action is taken) for packets that are traveling in the selected direction and do not match any of your customized rules.
Expand...	Click this to display more information.
Basic...	Click this to display less information.
Apply	Click this to save your changes.
Cancel	Click this to restore your previously saved settings.

9.3 The Firewall Rule Screen

Note: The ordering of your rules is very important as rules are applied in turn.

Refer to [Section 9.5 on page 149](#) for more information.

Click **Security > Firewall > Rules** to bring up the following screen. This screen displays a list of the configured firewall rules. Note the order in which the rules are listed.

Figure 56 Security > Firewall > Rules

The following table describes the labels in this screen.

Table 33 Security > Firewall > Rules

LABEL	DESCRIPTION
Firewall Rules Storage Space in Use	This read-only bar shows how much of the P-793H v2's memory for recording firewall rules it is currently using. When you are using 80% or less of the storage space, the bar is green. When the amount of space used is over 80%, the bar is red.
Packet Direction	Use the drop-down list box to select a direction of travel of packets for which you want to configure firewall rules.
Create a new rule after rule number	Select an index number and click Add to add a new firewall rule after the selected index number. For example, if you select "6", your new rule becomes number 7 and the previous rule 7 (if there is one) becomes rule 8.
	The following read-only fields summarize the rules you have created that apply to traffic traveling in the selected packet direction. The firewall rules that you configure (summarized below) take priority over the general firewall action settings in the General screen.
#	This is your firewall rule number. The ordering of your rules is important as rules are applied in turn.
Active	This field displays whether a firewall is turned on or not. Select the check box to enable the rule. Clear the check box to disable the rule.
Source IP	This drop-down list box displays the source addresses or ranges of addresses to which this firewall rule applies. Please note that a blank source or destination address is equivalent to Any .

Table 33 Security > Firewall > Rules (continued)

LABEL	DESCRIPTION
Destination IP	This drop-down list box displays the destination addresses or ranges of addresses to which this firewall rule applies. Please note that a blank source or destination address is equivalent to Any .
Service	This drop-down list box displays the services to which this firewall rule applies. See Appendix F on page 473 for more information.
Action	This field displays whether the firewall silently discards packets (Drop), discards packets and sends a TCP reset packet or an ICMP destination-unreachable message to the sender (Reject) or allows the passage of packets (Permit).
Schedule	This field tells you whether a schedule is specified (Yes) or not (No).
Log	This field shows you whether a log is created when packets match this rule (Yes) or not (No).
Modify	Click the Edit icon to go to the screen where you can edit the rule. Click the Remove icon to delete an existing firewall rule. A window displays asking you to confirm that you want to delete the firewall rule. Note that subsequent firewall rules move up by one when you take this action.
Order	Click the Move icon to display the Move the rule to field. Type a number in the Move the rule to field and click the Move button to move the rule to the number that you typed. The ordering of your rules is important as they are applied in order of their numbering.
Apply	Click this to save your changes.
Cancel	Click this to restore your previously saved settings.

9.3.1 Configuring Firewall Rules

Refer to [Section 9.1.2 on page 134](#) for more information.

Use this screen to configure firewall rules. In the **Rules** screen, select an index number and click **Add** or click a rule's **Edit** icon to display this screen and refer to the following table for information on the labels.

Figure 57 Security > Firewall > Rules: Edit

The screenshot shows the 'Edit Rule 1' configuration interface. It includes the following sections and controls:

- Active:** A checked checkbox.
- Action for Matched Packets:** A dropdown menu set to 'Permit'.
- Source Address:** Includes 'Address Type' (Any Address), 'Start IP Address' (0.0.0.0), 'End IP Address' (0.0.0.0), and 'Subnet Mask' (0.0.0.0). It also has 'Add >>', 'Edit <<', and 'Delete' buttons, and a 'Source Address List' containing 'Any'.
- Destination Address:** Similar to Source Address, with 'Add >>', 'Edit <<', and 'Delete' buttons, and a 'Destination Address List' containing 'Any'.
- Service:** Features an 'Available Services' list (Any(All), Any(ICMP), AIM/NEW-ICQ(TCP:5190), AUTH(TCP:113), BGP(TCP:179)), an 'Add >>' button, a 'Remove' button, and a 'Selected Services' list (Any(UDP), Any(TCP)). A link for 'Edit Customized Services' is also present.
- Schedule:** Includes 'Day to Apply' (checked for Everyday, Sun, Mon, Tue, Wed, Thu, Fri, Sat), 'Time of Day to Apply : (24-Hour Format)' (checked for All day), and 'Start' and 'End' time fields (0 hour 0 minute).
- Log:** A checkbox for 'Log Packet Detail Information'.
- Alert:** A checkbox for 'Send Alert Message to Administrator When Matched'.

At the bottom, there are 'Back', 'Apply', and 'Cancel' buttons.

The following table describes the labels in this screen.

Table 34 Security > Firewall > Rules: Edit

LABEL	DESCRIPTION
Edit Rule	
Active	Select this option to enable this firewall rule.

Table 34 Security > Firewall > Rules: Edit (continued)

LABEL	DESCRIPTION
Action for Matched Packet	Use the drop-down list box to select whether to discard (Drop), deny and send an ICMP destination-unreachable message to the sender of (Reject) or allow the passage of (Permit) packets that match this rule.
Destination Address	
Address Type	Do you want your rule to apply to packets with a particular (single) IP, a range of IP addresses (for instance, 192.168.1.10 to 192.169.1.50), a subnet or any IP address? Select an option from the drop-down list box that includes: Single Address , Range Address , Subnet Address and Any Address .
Start IP Address	Enter the single IP address or the starting IP address in a range here.
End IP Address	Enter the ending IP address in a range here.
Subnet Mask	Enter the subnet mask here, if applicable.
Add >>	Click Add >> to add a new address to the Source or Destination Address box. You can add multiple addresses, ranges of addresses, and/or subnets.
Edit <<	To edit an existing source or destination address, select it from the box and click Edit << .
Delete	Highlight an existing source or destination address from the Source or Destination Address box above and click Delete to remove it.
Services	
Available/ Selected Services	Please see Appendix F on page 473 for more information on services available. Highlight a service from the Available Services box on the left, then click Add >> to add it to the Selected Services box on the right. To remove a service, highlight it in the Selected Services box on the right, then click Remove .
Edit Customized Service	Click the Edit Customized Services link to bring up the screen that you use to configure a new custom service that is not in the predefined list of services.
Schedule	
Day to Apply	Select everyday or the day(s) of the week to apply the rule.
Time of Day to Apply (24-Hour Format)	Select All Day or enter the start and end times in the hour-minute format to apply the rule.
Log	
Log Packet Detail Information	This field determines if a log for packets that match the rule is created or not. Go to the Log Settings page and select the Access Control logs category to have the P-793H v2 record these logs.
Alert	
Send Alert Message to Administrator When Matched	Select the check box to have the P-793H v2 generate an alert when the rule is matched.
Back	Click this to return to the previous screen without saving.
Apply	Click this to save your changes.
Cancel	Click this to restore your previously saved settings.

9.3.2 Customized Services

Configure customized services and port numbers not predefined by the P-793H v2. For a comprehensive list of port numbers and services, visit the IANA (Internet Assigned Number Authority) website. See [Appendix F on page 473](#) for some examples. Click the **Edit Customized Services** link while editing a firewall rule to configure a custom service port. This displays the following screen.

Figure 58 Security > Firewall > Rules: Edit: Edit Customized Services

No.	Name	Protocol	Port
1			
2			
3			
4			
5			
6			
7			
8			
9			
10			

[Back](#)

The following table describes the labels in this screen.

Table 35 Security > Firewall > Rules: Edit: Edit Customized Services

LABEL	DESCRIPTION
No.	This is the number of your customized port. Click a rule's number of a service to go to the Firewall Customized Services Config screen to configure or edit a customized service.
Name	This is the name of your customized service.
Protocol	This shows the IP protocol (TCP , UDP or TCP/UDP) that defines your customized service.
Port	This is the port number or range that defines your customized service.
Back	Click this to return to the Firewall Edit Rule screen.

9.3.3 Configuring a Customized Service

Use this screen to add a customized rule or edit an existing rule. Click a rule number in the **Firewall Customized Services** screen to display the following screen.

Figure 59 Security > Firewall > Rules: Edit: Edit Customized Services: Config

The following table describes the labels in this screen.

Table 36 Security > Firewall > Rules: Edit: Edit Customized Services: Config

LABEL	DESCRIPTION
Config	
Service Name	Type a unique name for your custom port.
Service Type	Choose the IP port (TCP , UDP or TCP/UDP) that defines your customized port from the drop down list box.
Port Configuration	
Type	Click Single to specify one port only or Range to specify a span of ports that define your customized service.
Port Number	Type a single port number or the range of port numbers that define your customized service.
Back	Click this to return to the previous screen without saving.
Apply	Click this to save your changes.
Cancel	Click this to restore your previously saved settings.
Delete	Click this to delete the current rule.

9.4 The Firewall Threshold Screen

For DoS attacks, the P-793H v2 uses thresholds to determine when to start dropping sessions that do not become fully established (half-open sessions). These thresholds apply globally to all sessions.

For TCP, half-open means that the session has not reached the established state—the TCP three-way handshake has not yet been completed. Under normal

circumstances, the application that initiates a session sends a SYN (synchronize) packet to the receiving server. The receiver sends back an ACK (acknowledgment) packet and its own SYN, and then the initiator responds with an ACK (acknowledgment). After this handshake, a connection is established.

Figure 60 Three-Way Handshake

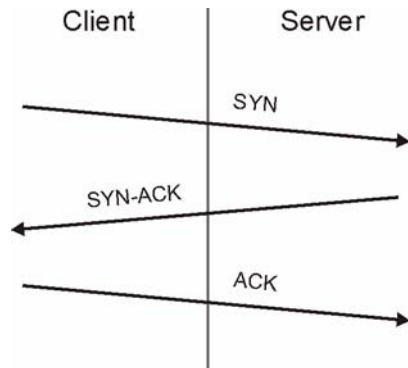

For UDP, half-open means that the firewall has detected no return traffic. An unusually high number (or arrival rate) of half-open sessions could indicate a DOS attack.

9.4.1 Threshold Values

If everything is working properly, you probably do not need to change the threshold settings as the default threshold values should work for most small offices. Tune these parameters when you believe the P-793H v2 has been receiving DoS attacks that are not recorded in the logs or the logs show that the P-793H v2 is classifying normal traffic as DoS attacks. Factors influencing choices for threshold values are:

- 1 The maximum number of opened sessions.
- 2 The minimum capacity of server backlog in your LAN network.
- 3 The CPU power of servers in your LAN network.
- 4 Network bandwidth.
- 5 Type of traffic for certain servers.

Reduce the threshold values if your network is slower than average for any of these factors (especially if you have servers that are slow or handle many tasks and are often busy).

- If you often use P2P applications such as file sharing with eMule or eDonkey, it's recommended that you increase the threshold values since lots of sessions will be established during a small period of time and the P-793H v2 may classify them as DoS attacks.

9.4.2 Configuring Firewall Thresholds

The P-793H v2 also sends alerts whenever **TCP Maximum Incomplete** is exceeded. The global values specified for the threshold and timeout apply to all TCP connections.

Click **Firewall > Threshold** to bring up the next screen.

Figure 61 Security > Firewall > Threshold

The following table describes the labels in this screen.

Table 37 Security > Firewall > Threshold

LABEL	DESCRIPTION
Denial of Service Thresholds	The P-793H v2 measures both the total number of existing half-open sessions and the rate of session establishment attempts. Both TCP and UDP half-open sessions are counted in the total number and rate measurements. Measurements are made once a minute.
One Minute Low	This is the rate of new half-open sessions per minute that causes the firewall to stop deleting half-open sessions. The P-793H v2 continues to delete half-open sessions as necessary, until the rate of new connection attempts drops below this number.

Table 37 Security > Firewall > Threshold (continued)

LABEL	DESCRIPTION
One Minute High	<p>This is the rate of new half-open sessions per minute that causes the firewall to start deleting half-open sessions. When the rate of new connection attempts rises above this number, the P-793H v2 deletes half-open sessions as required to accommodate new connection attempts.</p> <p>For example, if you set the one minute high to 100, the P-793H v2 starts deleting half-open sessions when more than 100 session establishment attempts have been detected in the last minute. It stops deleting half-open sessions when the number of session establishment attempts detected in a minute goes below the number set as the one minute low.</p>
Maximum Incomplete Low	<p>This is the number of existing half-open sessions that causes the firewall to stop deleting half-open sessions. The P-793H v2 continues to delete half-open requests as necessary, until the number of existing half-open sessions drops below this number.</p>
Maximum Incomplete High	<p>This is the number of existing half-open sessions that causes the firewall to start deleting half-open sessions. When the number of existing half-open sessions rises above this number, the P-793H v2 deletes half-open sessions as required to accommodate new connection requests. Do not set Maximum Incomplete High to lower than the current Maximum Incomplete Low number.</p> <p>For example, if you set the maximum incomplete high to 100, the P-793H v2 starts deleting half-open sessions when the number of existing half-open sessions rises above 100. It stops deleting half-open sessions when the number of existing half-open sessions drops below the number set as the maximum incomplete low.</p>
TCP Maximum Incomplete	<p>An unusually high number of half-open sessions with the same destination host address could indicate that a DoS attack is being launched against the host.</p> <p>Specify the number of existing half-open TCP sessions with the same destination host IP address that causes the firewall to start dropping half-open sessions to that same destination host IP address. Enter a number between 1 and 256. As a general rule, you should choose a smaller number for a smaller network, a slower system or limited bandwidth. The P-793H v2 sends alerts whenever the TCP Maximum Incomplete is exceeded.</p>
Action taken when TCP Maximum Incomplete reached threshold	<p>Select the action that P-793H v2 should take when the TCP maximum incomplete threshold is reached. You can have the P-793H v2 either:</p> <p>Delete the oldest half open session when a new connection request comes.</p> <p>or</p> <p>Deny new connection requests for the number of minutes that you specify (between 1 and 255).</p>
Apply	Click this to save your changes.
Cancel	Click this to restore your previously saved settings.

9.5 Firewall Technical Reference

This section provides some technical background information about the topics covered in this chapter.

9.5.1 Firewall Rules Overview

Your customized rules take precedence and override the P-793H v2's default settings. The P-793H v2 checks the source IP address, destination IP address and IP protocol type of network traffic against the firewall rules (in the order you list them). When the traffic matches a rule, the P-793H v2 takes the action specified in the rule.

Firewall rules are grouped based on the direction of travel of packets to which they apply:

- LAN to LAN/ Router
- LAN to WAN
- WAN to LAN
- WAN to WAN/ Router

By default, the P-793H v2's stateful packet inspection allows packets traveling in the following directions:

- LAN to LAN/ Router

These rules specify which computers on the LAN can manage the P-793H v2 (remote management) and communicate between networks or subnets connected to the LAN interface (IP alias).

Note: You can also configure the remote management settings to allow only a specific computer to manage the P-793H v2.

- LAN to WAN

These rules specify which computers on the LAN can access which computers or services on the WAN.

By default, the P-793H v2's stateful packet inspection drops packets traveling in the following directions:

- WAN to LAN

These rules specify which computers on the WAN can access which computers or services on the LAN.

Note: You also need to configure NAT port forwarding (or full featured NAT address mapping rules) to allow computers on the WAN to access devices on the LAN.

- WAN to WAN/ Router

By default the P-793H v2 stops computers on the WAN from managing the P-793H v2 or using the P-793H v2 as a gateway to communicate with other computers on the WAN. You could configure one of these rules to allow a WAN computer to manage the P-793H v2.

Note: You also need to configure the remote management settings to allow a WAN computer to manage the P-793H v2.

You may define additional rules and sets or modify existing ones but please exercise extreme caution in doing so.

For example, you may create rules to:

- Block certain types of traffic, such as IRC (Internet Relay Chat), from the LAN to the Internet.
- Allow certain types of traffic, such as Lotus Notes database synchronization, from specific hosts on the Internet to specific hosts on the LAN.
- Allow everyone except your competitors to access a web server.
- Restrict use of certain protocols, such as Telnet, to authorized users on the LAN.

These custom rules work by comparing the source IP address, destination IP address and IP protocol type of network traffic to rules set by the administrator. Your customized rules take precedence and override the P-793H v2's default rules.

9.5.2 Guidelines For Enhancing Security With Your Firewall

- 6 Change the default password via web configurator.
- 7 Think about access control before you connect to the network in any way.
- 8 Limit who can access your router.
- 9 Don't enable any local service (such as telnet or FTP) that you don't use. Any enabled service could present a potential security risk. A determined hacker might be able to find creative ways to misuse the enabled services to access the firewall or the network.
- 10 For local services that are enabled, protect against misuse. Protect by configuring the services to communicate only with specific peers, and protect by configuring rules to block packets for the services at specific interfaces.
- 11 Protect against IP spoofing by making sure the firewall is active.
- 12 Keep the firewall in a secured (locked) room.

9.5.3 Security Considerations

Note: Incorrectly configuring the firewall may block valid access or introduce security risks to the P-793H v2 and your protected network. Use caution when creating or deleting firewall rules and test your rules after you configure them.

Consider these security ramifications before creating a rule:

- 1 Does this rule stop LAN users from accessing critical resources on the Internet? For example, if IRC is blocked, are there users that require this service?
- 2 Is it possible to modify the rule to be more specific? For example, if IRC is blocked for all users, will a rule that blocks just certain users be more effective?
- 3 Does a rule that allows Internet users access to resources on the LAN create a security vulnerability? For example, if FTP ports (TCP 20, 21) are allowed from the Internet to the LAN, Internet users may be able to connect to computers with running FTP servers.
- 4 Does this rule conflict with any existing rules?

Once these questions have been answered, adding rules is simply a matter of entering the information into the correct fields in the web configurator screens.

9.5.4 Triangle Route

When the firewall is on, your P-793H v2 acts as a secure gateway between your LAN and the Internet. In an ideal network topology, all incoming and outgoing network traffic passes through the P-793H v2 to protect your LAN against attacks.

Figure 62 Ideal Firewall Setup

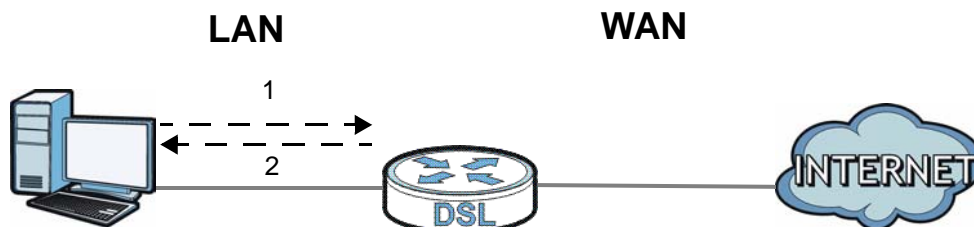

9.5.4.1 The “Triangle Route” Problem

A traffic route is a path for sending or receiving data packets between two Ethernet devices. You may have more than one connection to the Internet (through one or more ISPs). If an alternate gateway is on the LAN (and its IP address is in the same subnet as the P-793H v2’s LAN IP address), the “triangle route” (also called asymmetrical route) problem may occur. The steps below describe the “triangle route” problem.

- 1 A computer on the LAN initiates a connection by sending out a SYN packet to a receiving server on the WAN.
- 2 The P-793H v2 reroutes the SYN packet through Gateway **A** on the LAN to the WAN.
- 3 The reply from the WAN goes directly to the computer on the LAN without going through the P-793H v2.

As a result, the P-793H v2 resets the connection, as the connection has not been acknowledged.

Figure 63 “Triangle Route” Problem

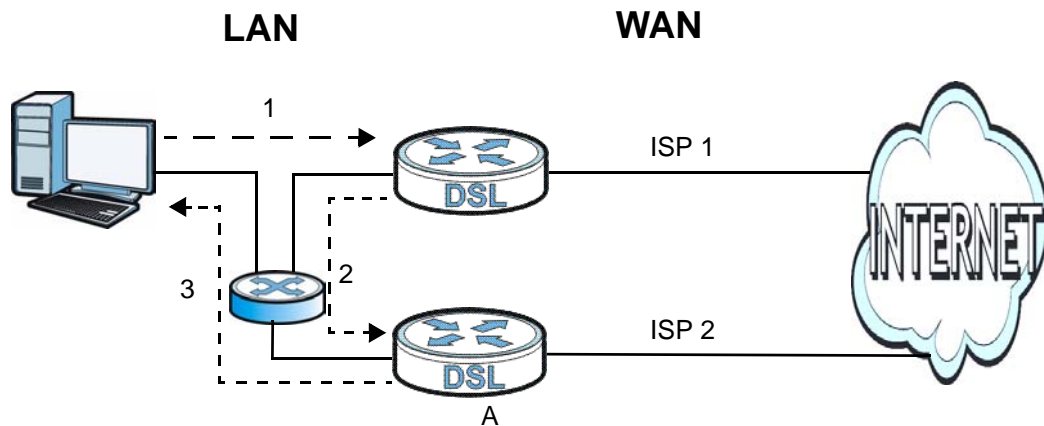

9.5.4.2 Solving the “Triangle Route” Problem

If you have the P-793H v2 allow triangle route sessions, traffic from the WAN can go directly to a LAN computer without passing through the P-793H v2 and its firewall protection.

Another solution is to use IP alias. IP alias allows you to partition your network into logical sections over the same Ethernet interface. Your P-793H v2 supports up to three logical LAN interfaces with the P-793H v2 being the gateway for each logical network.

It's like having multiple LAN networks that actually use the same physical cables and ports. By putting your LAN and Gateway **A** in different subnets, all returning network traffic must pass through the P-793H v2 to your LAN. The following steps describe such a scenario.

- 1 A computer on the LAN initiates a connection by sending a SYN packet to a receiving server on the WAN.
- 2 The P-793H v2 reroutes the packet to Gateway A, which is in Subnet 2.
- 3 The reply from the WAN goes to the P-793H v2.
- 4 The P-793H v2 then sends it to the computer on the LAN in Subnet 1.

Figure 64 IP Alias

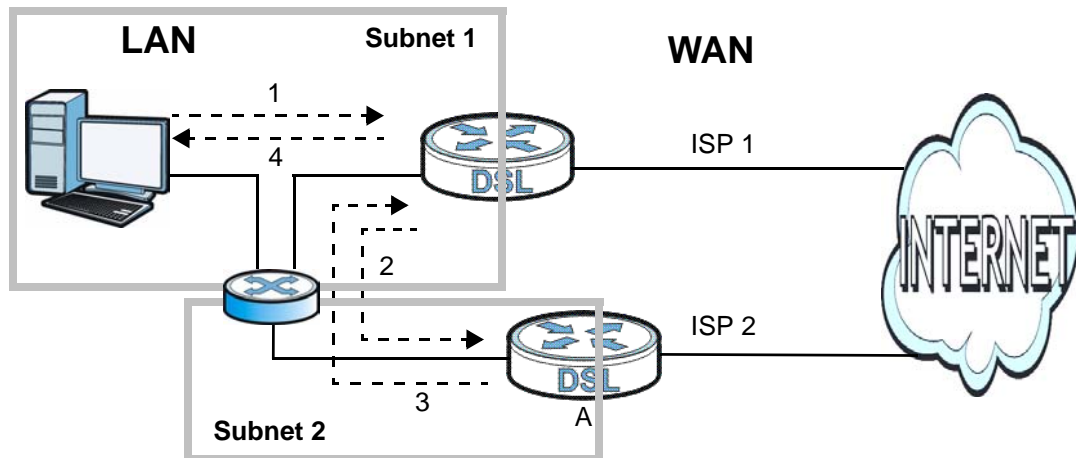

Content Filtering

10.1 Overview

Internet content filtering allows you to block web sites based on keywords in the URL.

See [Section 10.1.4 on page 156](#) for an example of setting up content filtering.

10.1.1 What You Can Do in the Content Filter Screens

- Use the **Keyword** screen ([Section 10.2 on page 158](#)) to block web sites based on a keyword in the URL.
- Use the **Schedule** screen ([Section 10.3 on page 159](#)) to specify the days and times keyword blocking is active.
- Use the **Trusted** screen ([Section 10.4 on page 160](#)) to exclude computers and other devices on your LAN from the keyword blocking filter.

10.1.2 What You Need to Know About Content Filtering

URL

The URL (Uniform Resource Locator) identifies and helps locates resources on a network. On the Internet the URL is the web address that you type in the address bar of your Internet browser, for example “<http://www.zyxel.com>”.

10.1.3 Before You Begin

To use the **Trusted** screen, you need the IP addresses of devices on your network. See the **LAN** section ([Section 10.4 on page 160](#)) for more information.

10.1.4 Content Filtering Example

The following shows the steps required for a parent (Bob) to set up content filtering on a home network in order to limit his children's access to certain web sites. In the following example, all URLs containing the word 'bad' are blocked.

- 1 Click **Security > Content Filter** to display the following screen.
- 2 Select **Active Keyword Blocking**.
- 3 In the **Keyword** field type keywords to identify websites to be blocked.
- 4 Click **Add Keyword** for each keyword to be entered.
- 5 Click **Apply**.

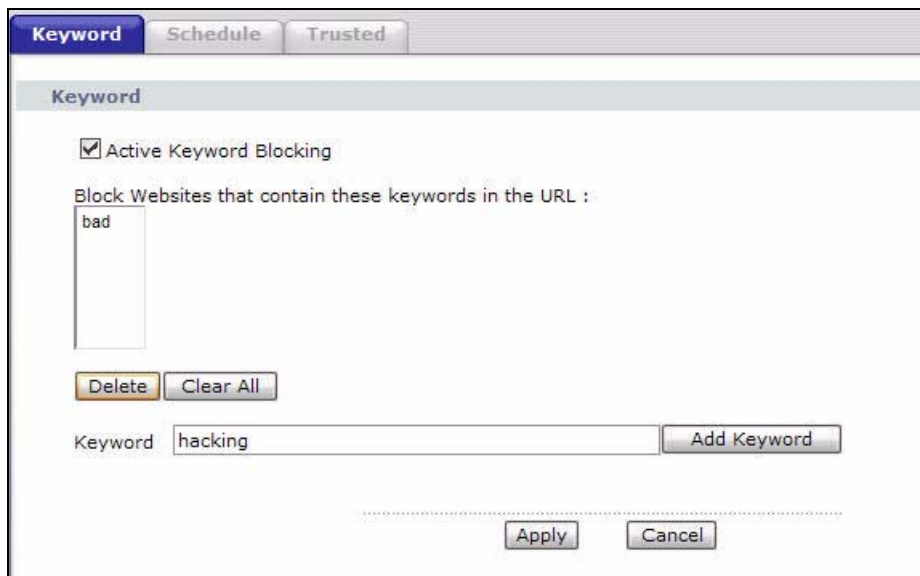

Bob's son arrives home from school at four, while his parents arrive later, at about 7pm. So keyword blocking is enabled for these times on weekdays and not on the weekend when the parents are at home.

- 1 Click **Security > Content Filter > Schedule**.
- 2 Click **Edit Daily to Block** and select all weekdays.
- 3 Under **Start Time** and **End Time**, type the times for blocking to begin and end (16:00 ~ 17:00 in this example).

4 Click **Apply**.

Schedule

Block Everyday
 Edit Daily to Block

	Active	Start Time	End Time
Monday	<input checked="" type="checkbox"/>	16 hr 0 min	19 hr 0 min
Tuesday	<input checked="" type="checkbox"/>	16 hr 0 min	19 hr 0 min
Wednesday	<input checked="" type="checkbox"/>	16 hr 0 min	19 hr 0 min
Thursday	<input checked="" type="checkbox"/>	16 hr 0 min	19 hr 0 min
Friday	<input checked="" type="checkbox"/>	16 hr 0 min	19 hr 0 min
Saturday	<input type="checkbox"/>	0 hr 0 min	0 hr 0 min
Sunday	<input type="checkbox"/>	0 hr 0 min	0 hr 0 min

Apply Cancel

The children can access the family computer in the living room, while only the parents use another computer in the study room. So keyword blocking is only needed on the family computer and the study computer can be excluded from keyword blocking. Bob's home network is on the domain "192.168.1.xxx". Bob gave his home computer a static IP address of 192.168.1.2 and the study computer a static IP address of 192.168.1.3. To exclude the study computer from keyword blocking he follows these steps.

- 1 Click **Security > Content Filter > Trusted**.
- 2 In the **Start IP Address** and **End IP Address** fields, type 192.168.1.3.
- 3 Click **Apply**.

Trusted

Trusted User IP Range

Start IP Address: 192.168.1.3
 End IP Address: 192.168.1.3

Apply Cancel

That finishes setting up keyword blocking on the home computer.

10.2 The Keyword Screen

Use this screen to block sites containing certain keywords in the URL. For example, if you enable the keyword "bad", the P-793H v2 blocks all sites containing this keyword including the URL <http://www.example.com/bad.html>.

To have your P-793H v2 block websites containing keywords in their URLs, click **Security > Content Filter**. The screen appears as shown.

Figure 65 Security > Content Filtering > Keyword

The following table describes the labels in this screen.

Table 38 Security > Content Filtering > Keyword

LABEL	DESCRIPTION
Active Keyword Blocking	Select this check box to enable this feature.
Block Websites that contain these keywords in the URL:	This box contains the list of all the keywords that you have configured the P-793H v2 to block.
Delete	Highlight a keyword in the box and click this to remove it.
Clear All	Click this to remove all of the keywords from the list.
Keyword	Type a keyword in this field. You may use any character (up to 127 characters). Wildcards are not allowed.
Add Keyword	Click this after you have typed a keyword. Repeat this procedure to add other keywords. Up to 64 keywords are allowed. When you try to access a web page containing a keyword, you will get a message telling you that the content filter is blocking this request.

Table 38 Security > Content Filtering > Keyword (continued)

LABEL	DESCRIPTION
Apply	Click this to save your changes.
Cancel	Click this to restore your previously saved settings.

10.3 The Schedule Screen

Use this screen to set the days and times for the P-793H v2 to perform content filtering. Click **Security > Content Filter > Schedule**. The screen appears as shown.

Figure 66 Security > Content Filter > Schedule

Day	Active	Start Time	End Time
Monday	<input type="checkbox"/>	0 hr 0 min	0 hr 0 min
Tuesday	<input type="checkbox"/>	0 hr 0 min	0 hr 0 min
Wednesday	<input type="checkbox"/>	0 hr 0 min	0 hr 0 min
Thursday	<input type="checkbox"/>	0 hr 0 min	0 hr 0 min
Friday	<input type="checkbox"/>	0 hr 0 min	0 hr 0 min
Saturday	<input type="checkbox"/>	0 hr 0 min	0 hr 0 min
Sunday	<input type="checkbox"/>	0 hr 0 min	0 hr 0 min

The following table describes the labels in this screen.

Table 39 Security > Content Filter: Schedule

LABEL	DESCRIPTION
Schedule	Select Block Everyday to make the content filtering active everyday. Otherwise, select Edit Daily to Block and configure which days of the week (or everyday) and which time of the day you want the content filtering to be active.
Active	Select the check box to have the content filtering to be active on the selected day.
Start Time	Enter the time when you want the content filtering to take effect in hour-minute format.
End Time	Enter the time when you want the content filtering to stop in hour-minute format.

Table 39 Security > Content Filter: Schedule (continued)

LABEL	DESCRIPTION
Apply	Click this to save your changes.
Cancel	Click this to restore your previously saved settings.

10.4 The Trusted Screen

Use this screen to exclude a range of users on the LAN from content filtering on your P-793H v2. Click **Security > Content Filter > Trusted**. The screen appears as shown.

Figure 67 Security > Content Filter: Trusted

The following table describes the labels in this screen.

Table 40 Security > Content Filter: Trusted

LABEL	DESCRIPTION
Start IP Address	Type the IP address of a computer (or the beginning IP address of a specific range of computers) on the LAN that you want to exclude from content filtering.
End IP Address	Type the ending IP address of a specific range of users on your LAN that you want to exclude from content filtering. Leave this field blank if you want to exclude an individual computer.
Apply	Click this to save your changes.
Cancel	Click this to restore your previously saved settings.

11.1 Overview

A virtual private network (VPN) provides secure communications between sites without the expense of leased site-to-site lines. A secure VPN is a combination of tunneling, encryption, authentication, access control and auditing. It is used to transport traffic over the Internet or any insecure network that uses TCP/IP for communication.

Internet Protocol Security (IPSec) is a standards-based VPN that offers flexible solutions for secure data communications across a public network like the Internet. IPSec is built around a number of standardized cryptographic techniques to provide confidentiality, data integrity and authentication at the IP layer. The following figure is an example of an IPSec VPN tunnel.

Figure 68 VPN: Example

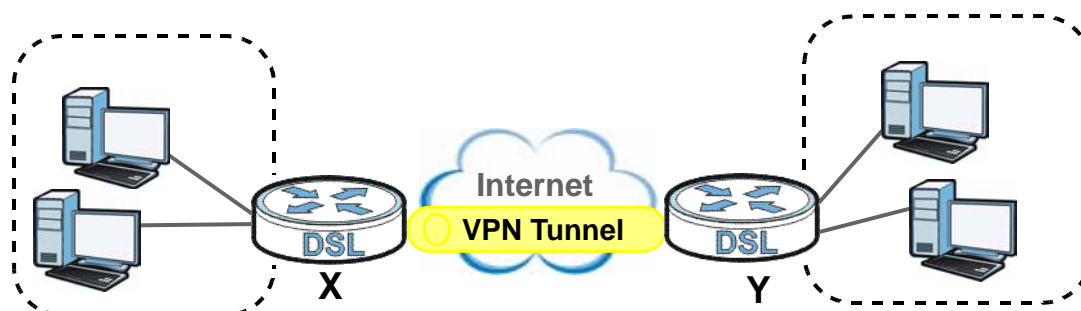

11.1.1 What You Can Do in the VPN Screens

- Use the **Setup** screen ([Section 11.2 on page 163](#)) to view the configured VPN policies and add, edit or remove a VPN policy.
- Use the **Monitor** screen ([Section 11.7 on page 177](#)) to display and manage the current active VPN connections.
- Use the **VPN Global Setting** screen ([Section 11.8 on page 179](#)) to allow NetBIOS packets passing through the VPN connection.

11.1.2 What You Need to Know About IPSec VPN

A VPN tunnel is usually established in two phases. Each phase establishes a security association (SA), a contract indicating what security parameters the P-793H v2 and the remote IPSec router will use. The first phase establishes an Internet Key Exchange (IKE) SA between the P-793H v2 and remote IPSec router. The second phase uses the IKE SA to securely establish an IPSec SA through which the P-793H v2 and remote IPSec router can send data between computers on the local network and remote network. The following figure illustrates this.

Figure 69 VPN: IKE SA and IPSec SA

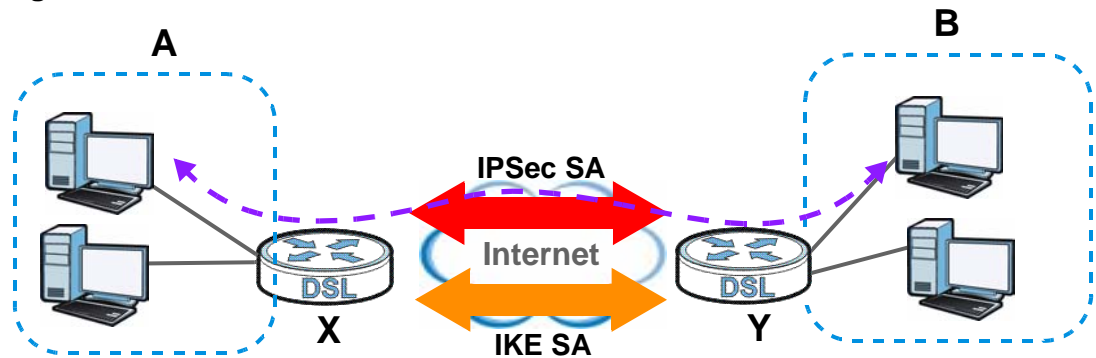

In this example, a computer in network **A** is exchanging data with a computer in network **B**. Inside networks **A** and **B**, the data is transmitted the same way data is normally transmitted in the networks. Between routers **X** and **Y**, the data is protected by tunneling, encryption, authentication, and other security features of the IPSec SA. The IPSec SA is established securely using the IKE SA that routers **X** and **Y** established first.

My IP Address

My IP Address is the WAN IP address of the P-793H v2. The P-793H v2 has to rebuild the VPN tunnel if **My IP Address** changes after setup.

The following applies if this field is configured as **0.0.0.0**:

- The P-793H v2 uses the current P-793H v2 WAN IP address (static or dynamic) to set up the VPN tunnel.

Secure Gateway Address

Secure Gateway Address is the WAN IP address or domain name of the remote IPSec router (secure gateway).

If the remote secure gateway has a static WAN IP address, enter it in the **Secure Gateway Address** field. You may alternatively enter the remote secure gateway's domain name (if it has one) in the **Secure Gateway Address** field.

You can also enter a remote secure gateway's domain name in the **Secure Gateway Address** field if the remote secure gateway has a dynamic WAN IP address and is using DDNS. The P-793H v2 has to rebuild the VPN tunnel each time the remote secure gateway's WAN IP address changes (there may be a delay until the DDNS servers are updated with the remote gateway's new WAN IP address).

Dynamic Secure Gateway Address

If the remote secure gateway has a dynamic WAN IP address and does not use DDNS, enter 0.0.0.0 as the secure gateway's address. In this case only the remote secure gateway can initiate SAs. This may be useful for telecommuters initiating a VPN tunnel to the company network (see [Section 11.9.12 on page 188](#) for configuration examples).

The Secure Gateway IP Address may be configured as **0.0.0.0** only when using **IKE** key management and not **Manual** key management.

Finding Out More

See [Section 11.9 on page 179](#) for advanced technical information on IPsec VPN.

11.1.3 Before You Begin

If a VPN tunnel uses Telnet, FTP, WWW, then you should configure remote management (**Remote MGMT**) to allow access for that service.

11.2 VPN Setup Screen

The following figure helps explain the main fields in the web configurator.

Figure 70 IPsec Summary Fields

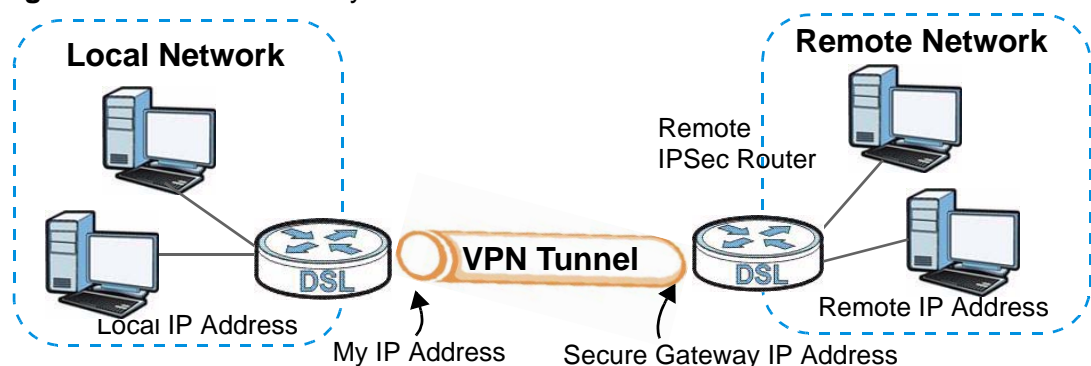

Local and remote IP addresses must be static.

Click **Security > VPN** to open the **VPN Setup** screen. This is a menu of your IPSec rules (tunnels). The IPSec summary menu is read-only. Edit a VPN by selecting an index number and then configuring its associated submenus.

Figure 71 Security > VPN > Setup

The screenshot shows the 'VPN Setup' screen with a 'Summary' section. It contains a table with 10 rows, each representing a VPN policy. The columns are: No., Active, Name, Local Address, Remote Address, Encap., IPSec Algorithm, Secure Gateway IP, and Modify. The 'Modify' column contains edit and delete icons. Below the table are 'Apply' and 'Cancel' buttons.

No.	Active	Name	Local Address	Remote Address	Encap.	IPSec Algorithm	Secure Gateway IP	Modify
1	-	-	-	-	...	
2	-	-	-	-	...	
3	-	-	-	-	...	
4	-	-	-	-	...	
5	-	-	-	-	...	
6	-	-	-	-	...	
7	-	-	-	-	...	
8	-	-	-	-	...	
9	-	-	-	-	...	
10	-	-	-	-	...	

The following table describes the fields in this screen.

Table 41 Security > VPN > Setup

LABEL	DESCRIPTION
No.	This is the VPN policy index number. Click a number to edit VPN policies.
Active	This field displays whether the VPN policy is active or not. A Yes signifies that this VPN policy is active. No signifies that this VPN policy is not active.
Name	This field displays the identification name for this VPN policy.
Local Address	<p>This is the IP address(es) of computer(s) on your local network behind your P-793H v2.</p> <p>The same (static) IP address is displayed twice when the Local Address Type field in the VPN Setup - Edit screen is configured to Single.</p> <p>The beginning and ending (static) IP addresses, in a range of computers are displayed when the Local Address Type field in the VPN Setup - Edit screen is configured to Range.</p> <p>A (static) IP address and a subnet mask are displayed when the Local Address Type field in the VPN Setup - Edit screen is configured to Subnet.</p>

Table 41 Security > VPN > Setup (continued)

LABEL	DESCRIPTION
Remote Address	<p>This is the IP address(es) of computer(s) on the remote network behind the remote IPSec router.</p> <p>This field displays N/A when the Secure Gateway Address field displays 0.0.0.0. In this case only the remote IPSec router can initiate the VPN.</p> <p>The same (static) IP address is displayed twice when the Remote Address Type field in the VPN Setup - Edit screen is configured to Single.</p> <p>The beginning and ending (static) IP addresses, in a range of computers are displayed when the Remote Address Type field in the VPN Setup - Edit screen is configured to Range.</p> <p>A (static) IP address and a subnet mask are displayed when the Remote Address Type field in the VPN Setup - Edit screen is configured to Subnet.</p>
Encap.	This field displays Tunnel or Transport mode (Tunnel is the default selection).
IPSec Algorithm	<p>This field displays the security protocols used for an SA.</p> <p>Both AH and ESP increase P-793H v2 processing requirements and communications latency (delay).</p>
Secure Gateway IP	This is the static WAN IP address or URL of the remote IPSec router. This field displays 0.0.0.0 when you configure the Secure Gateway Address field in the VPN-IKE screen to 0.0.0.0 .
Modify	<p>Click the Edit icon to go to the screen where you can edit the VPN configuration.</p> <p>Click the Remove icon to remove an existing VPN configuration.</p>
Apply	Click this to save your changes and apply them to the P-793H v2.
Cancel	Click this return your settings to their last saved values.

11.3 The VPN Edit Screen

Click an **Edit** icon in the **VPN Setup** screen to edit VPN policies.

Figure 72 Security > VPN > Setup > Edit

The screenshot shows the 'IPsec Setup' configuration screen. It is organized into several sections:

- IPsec Setup:** Includes checkboxes for 'Active', 'Keep Alive', and 'NAT Traversal'. Fields for 'Name', 'IPsec Key Mode' (IKE), 'Negotiation Mode' (Main), 'Encapsulation Mode' (Tunnel), and 'DNS Server (for IPsec VPN)' (0.0.0.0).
- Local:** Fields for 'Local Address Type' (Single), 'IP Address Start' (0.0.0.0), and 'End / Subnet Mask' (0.0.0.0).
- Remote:** Fields for 'Remote Address Type' (Single), 'IP Address Start' (0.0.0.0), and 'End / Subnet Mask' (0.0.0.0).
- Address Information:** Fields for 'Local ID Type' (IP), 'Content', 'My IP Address' (0.0.0.0), 'Peer ID Type' (IP), 'Content', and 'Secure Gateway Address' (0.0.0.0).
- Security Protocol:** Fields for 'VPN Protocol' (ESP), 'Pre-Shared Key', 'Encryption Algorithm' (DES), and 'Authentication Algorithm' (SHA1).

At the bottom, there are buttons for 'Back', 'Apply', 'Cancel', and 'Advanced Setup'.

The following table describes the fields in this screen.

Table 42 Security > VPN > Setup > Edit

LABEL	DESCRIPTION
IPsec Setup	
Active	Select this check box to activate this VPN policy. This option determines whether a VPN rule is applied before a packet leaves the firewall.
Keep Alive	Select either Yes or No from the drop-down list box. Select Yes to have the P-793H v2 automatically reinitiate the SA after the SA lifetime times out, even if there is no traffic. The remote IPsec router must also have keep alive enabled in order for this feature to work.

Table 42 Security > VPN > Setup > Edit

LABEL	DESCRIPTION
NAT Traversal	<p>This function is available if the VPN Protocol is ESP.</p> <p>Select this check box if you want to set up a VPN tunnel when there are NAT routers between the P-793H v2 and remote IPsec router. The remote IPsec router must also enable NAT traversal, and the NAT routers have to forward UDP port 500 packets to the remote IPsec router behind the NAT router.</p>
Name	Type up to 32 characters to identify this VPN policy. You may use any character, including spaces, but the P-793H v2 drops trailing spaces.
IPsec Key Mode	Select IKE or Manual from the drop-down list box. IKE provides more protection so it is generally recommended. Manual is a useful option for troubleshooting if you have problems using IKE key management.
Negotiation Mode	Select Main or Aggressive from the drop-down list box. Multiple SAs connecting through a secure gateway must have the same negotiation mode.
Encapsulation Mode	Select Tunnel mode or Transport mode from the drop-down list box.
DNS Server (for IPsec VPN)	<p>If there is a private DNS server that services the VPN, type its IP address here. The P-793H v2 assigns this additional DNS server to the P-793H v2's DHCP clients that have IP addresses in this IPsec rule's range of local addresses.</p> <p>A DNS server allows clients on the VPN to find other computers and servers on the VPN by their (private) domain names.</p>
Local	<p>Specify the IP addresses of the devices behind the P-793H v2 that can use the VPN tunnel. The local IP addresses must correspond to the remote IPsec router's configured remote IP addresses.</p> <p>Two active SAs cannot have the local and remote IP address(es) both the same. Two active SAs can have the same local or remote IP address, but not both. You can configure multiple SAs between the same local and remote IP addresses, as long as only one is active at any time.</p>
Local Address Type	Use the drop-down menu to choose Single , Range , or Subnet . Select Single for a single IP address. Select Range for a specific range of IP addresses. Select Subnet to specify IP addresses on a network by their subnet mask.
IP Address Start	When the Local Address Type field is configured to Single , enter a (static) IP address on the LAN behind your P-793H v2. When the Local Address Type field is configured to Range , enter the beginning (static) IP address, in a range of computers on your LAN behind your P-793H v2. When the Local Address Type field is configured to Subnet , this is a (static) IP address on the LAN behind your P-793H v2.
End / Subnet Mask	When the Local Address Type field is configured to Single , this field is N/A. When the Local Address Type field is configured to Range , enter the end (static) IP address, in a range of computers on the LAN behind your P-793H v2. When the Local Address Type field is configured to Subnet , this is a subnet mask on the LAN behind your P-793H v2.

Table 42 Security > VPN > Setup > Edit

LABEL	DESCRIPTION
Remote	<p>Specify the IP addresses of the devices behind the remote IPSec router that can use the VPN tunnel. The remote IP addresses must correspond to the remote IPSec router's configured local IP addresses.</p> <p>Two active SAs cannot have the local and remote IP address(es) both the same. Two active SAs can have the same local or remote IP address, but not both. You can configure multiple SAs between the same local and remote IP addresses, as long as only one is active at any time.</p>
Remote Address Type	<p>Use the drop-down menu to choose Single, Range, or Subnet. Select Single with a single IP address. Select Range for a specific range of IP addresses. Select Subnet to specify IP addresses on a network by their subnet mask.</p>
IP Address Start	<p>When the Remote Address Type field is configured to Single, enter a (static) IP address on the network behind the remote IPSec router. When the Remote Address Type field is configured to Range, enter the beginning (static) IP address, in a range of computers on the network behind the remote IPSec router. When the Remote Address Type field is configured to Subnet, enter a (static) IP address on the network behind the remote IPSec router.</p>
End / Subnet Mask	<p>When the Remote Address Type field is configured to Single, this field is N/A. When the Remote Address Type field is configured to Range, enter the end (static) IP address, in a range of computers on the network behind the remote IPSec router. When the Remote Address Type field is configured to Subnet, enter a subnet mask on the network behind the remote IPSec router.</p>
Address Information	
Local ID Type	<p>Select IP to identify this P-793H v2 by its IP address. Select DNS to identify this P-793H v2 by a domain name. Select E-mail to identify this P-793H v2 by an e-mail address.</p>
Content	<p>When you select IP in the Local ID Type field, type the IP address of your computer in the local Content field. The P-793H v2 automatically uses the IP address in the My IP Address field (refer to the My IP Address field description) if you configure the local Content field to 0.0.0.0 or leave it blank.</p> <p>It is recommended that you type an IP address other than 0.0.0.0 in the local Content field or use the DNS or E-mail ID type in the following situations.</p> <p>When there is a NAT router between the two IPSec routers.</p> <p>When you want the remote IPSec router to be able to distinguish between VPN connection requests that come in from IPSec routers with dynamic WAN IP addresses.</p> <p>When you select DNS or E-mail in the Local ID Type field, type a domain name or e-mail address by which to identify this P-793H v2 in the local Content field. Use up to 31 ASCII characters including spaces, although trailing spaces are truncated. The domain name or e-mail address is for identification purposes only and can be any string.</p>

Table 42 Security > VPN > Setup > Edit

LABEL	DESCRIPTION
My IP Address	<p>Enter the WAN IP address of your P-793H v2. The VPN tunnel has to be rebuilt if this IP address changes.</p> <p>The following applies if this field is configured as 0.0.0.0:</p> <p>The P-793H v2 uses the current P-793H v2 WAN IP address (static or dynamic) to set up the VPN tunnel.</p>
Peer ID Type	<p>Select IP to identify the remote IPSec router by its IP address.</p> <p>Select DNS to identify the remote IPSec router by a domain name.</p> <p>Select E-mail to identify the remote IPSec router by an e-mail address.</p>
Content	<p>The configuration of the peer content depends on the peer ID type.</p> <p>For IP, type the IP address of the computer with which you will make the VPN connection. If you configure this field to 0.0.0.0 or leave it blank, the P-793H v2 will use the address in the Secure Gateway Address field (refer to the Secure Gateway Address field description).</p> <p>For DNS or E-mail, type a domain name or e-mail address by which to identify the remote IPSec router. Use up to 31 ASCII characters including spaces, although trailing spaces are truncated. The domain name or e-mail address is for identification purposes only and can be any string.</p> <p>It is recommended that you type an IP address other than 0.0.0.0 or use the DNS or E-mail ID type in the following situations:</p> <p>When there is a NAT router between the two IPSec routers.</p> <p>When you want the P-793H v2 to distinguish between VPN connection requests that come in from remote IPSec routers with dynamic WAN IP addresses.</p>
Secure Gateway Address	<p>Type the WAN IP address or the URL (up to 31 characters) of the IPSec router with which you're making the VPN connection. Set this field to 0.0.0.0 if the remote IPSec router has a dynamic WAN IP address (the IPSec Key Mode field must be set to IKE).</p> <p>In order to have more than one active rule with the Secure Gateway Address field set to 0.0.0.0, the ranges of the local IP addresses cannot overlap between rules.</p> <p>If you configure an active rule with 0.0.0.0 in the Secure Gateway Address field and the LAN's full IP address range as the local IP address, then you cannot configure any other active rules with the Secure Gateway Address field set to 0.0.0.0.</p>
Security Protocol	
VPN Protocol	<p>Select ESP if you want to use ESP (Encapsulation Security Payload). The ESP protocol (RFC 2406) provides encryption as well as some of the services offered by AH. If you select ESP here, you must select options from the Encryption Algorithm and Authentication Algorithm fields (described below).</p>

Table 42 Security > VPN > Setup > Edit

LABEL	DESCRIPTION
Pre-Shared Key	<p>Click the button to use a pre-shared key for authentication, and type in your pre-shared key. A pre-shared key identifies a communicating party during a phase 1 IKE negotiation. It is called "pre-shared" because you have to share it with another party before you can communicate with them over a secure connection.</p> <p>Type from 8 to 31 case-sensitive ASCII characters or from 16 to 62 hexadecimal ("0-9", "A-F") characters. You must precede a hexadecimal key with a "0x" (zero x), which is not counted as part of the 16 to 62 character range for the key. For example, in "0x0123456789ABCDEF", "0x" denotes that the key is hexadecimal and "0123456789ABCDEF" is the key itself.</p> <p>Both ends of the VPN tunnel must use the same pre-shared key. You will receive a "PYLD_MALFORMED" (payload malformed) packet if the same pre-shared key is not used on both ends.</p>
Encryption Algorithm	<p>Select DES, 3DES, AES or NULL from the drop-down list box.</p> <p>When you use one of these encryption algorithms for data communications, both the sending device and the receiving device must use the same secret key, which can be used to encrypt and decrypt the message or to generate and verify a message authentication code. The DES encryption algorithm uses a 56-bit key. Triple DES (3DES) is a variation on DES that uses a 168-bit key. As a result, 3DES is more secure than DES. It also requires more processing power, resulting in increased latency and decreased throughput. This implementation of AES uses a 128-bit key. AES is faster than 3DES.</p> <p>Select NULL to set up a tunnel without encryption. When you select NULL, you do not enter an encryption key.</p>
Authentication Algorithm	<p>Select SHA1 or MD5 from the drop-down list box. MD5 (Message Digest 5) and SHA1 (Secure Hash Algorithm) are hash algorithms used to authenticate packet data. The SHA1 algorithm is generally considered stronger than MD5, but is slower. Select MD5 for minimal security and SHA-1 for maximum security.</p>
Back	Click Back to return to the previous screen.
Apply	Click Apply to save your changes back to the P-793H v2.
Cancel	Click Cancel to begin configuring this screen afresh.
Advanced Setup	Click Advanced Setup to configure more detailed settings of your IKE key management.

11.4 Configuring Advanced IKE Settings

Click **Advanced Setup** in the **VPN Setup-Edit** screen to open this screen.

Figure 73 Security > VPN > Setup > Edit > Advanced Setup

The screenshot shows the 'VPN - IKE - Advanced Setup' configuration window. It contains the following fields and options:

- Protocol:** Text input field with '0' entered.
- Enable Replay Detection:** Drop-down menu with 'NO' selected.
- Local Start Port:** Text input field with '0' entered.
- End:** Text input field with '0' entered.
- Remote Start Port:** Text input field with '0' entered.
- End:** Text input field with '0' entered.

Phase 1

- Negotiation Mode:** Drop-down menu with 'Main' selected.
- Pre-Shared Key:** Text input field (empty).
- Encryption Algorithm:** Drop-down menu with 'DES' selected.
- Authentication Algorithm:** Drop-down menu with 'MD5' selected.
- SA Life Time (Seconds):** Text input field with '28800' entered.
- Key Group:** Drop-down menu with 'DH1' selected.

Phase 2

- Active Protocol:** Drop-down menu with 'ESP' selected.
- Encryption Algorithm:** Drop-down menu with 'DES' selected.
- Authentication Algorithm:** Drop-down menu with 'SHA1' selected.
- SA Life Time (Seconds):** Text input field with '28800' entered.
- Encapsulation:** Drop-down menu with 'Tunnel' selected.
- Perfect Forward Secrecy (PFS):** Drop-down menu with 'NONE' selected.

At the bottom of the window are three buttons: **Back**, **Apply**, and **Cancel**.

The following table describes the fields in this screen.

Table 43 Security > VPN > Setup > Edit > Advanced Setup

LABEL	DESCRIPTION
VPN - IKE - Advanced Setup	
Protocol	Enter 1 for ICMP, 6 for TCP, 17 for UDP, and so on. 0 is the default and signifies any protocol.
Enable Replay Detection	As a VPN setup is processing intensive, the system is vulnerable to Denial of Service (DoS) attacks. The IPsec receiver can detect and reject old or duplicate packets to protect against replay attacks. Select YES from the drop-down menu to enable replay detection, or select NO to disable it.
Local Start Port	0 is the default and signifies any port. Type a port number from 0 to 65535. Some of the most common IP ports are: 21, FTP; 53, DNS; 23, Telnet; 80, HTTP; 25, SMTP; 110, POP3.
End	Enter a port number in this field to define a port range. This port number must be greater than that specified in the previous field. If Local Start Port is left at 0, End will also remain at 0.
Remote Start Port	0 is the default and signifies any port. Type a port number from 0 to 65535. Some of the most common IP ports are: 21, FTP; 53, DNS; 23, Telnet; 80, HTTP; 25, SMTP; 110, POP3.
End	Enter a port number in this field to define a port range. This port number must be greater than that specified in the previous field. If Remote Start Port is left at 0, End will also remain at 0.

Table 43 Security > VPN > Setup > Edit > Advanced Setup (continued)

LABEL	DESCRIPTION
Phase 1	
Negotiation Mode	Select Main or Aggressive from the drop-down list box. Multiple SAs connecting through a secure gateway must have the same negotiation mode.
Pre-Shared Key	<p>Type your pre-shared key in this field. A pre-shared key identifies a communicating party during a phase 1 IKE negotiation. It is called "pre-shared" because you have to share it with another party before you can communicate with them over a secure connection.</p> <p>Type from 8 to 31 case-sensitive ASCII characters or from 16 to 62 hexadecimal ("0-9", "A-F") characters. You must precede a hexadecimal key with a "0x" (zero x), which is not counted as part of the 16 to 62-character range for the key. For example, in "0x0123456789ABCDEF", "0x" denotes that the key is hexadecimal and "0123456789ABCDEF" is the key itself.</p> <p>Both ends of the VPN tunnel must use the same pre-shared key. You will receive a "PYLD_MALFORMED" (payload malformed) packet if the same pre-shared key is not used on both ends.</p>
Encryption Algorithm	<p>Select DES, 3DES or AES from the drop-down list box.</p> <p>When you use one of these encryption algorithms for data communications, both the sending device and the receiving device must use the same secret key, which can be used to encrypt and decrypt the message or to generate and verify a message authentication code. The DES encryption algorithm uses a 56-bit key. Triple DES (3DES) is a variation on DES that uses a 168-bit key. As a result, 3DES is more secure than DES. It also requires more processing power, resulting in increased latency and decreased throughput. This implementation of AES uses a 128-bit key. AES is faster than 3DES.</p>
Authentication Algorithm	Select SHA1 or MD5 from the drop-down list box. MD5 (Message Digest 5) and SHA1 (Secure Hash Algorithm) are hash algorithms used to authenticate packet data. The SHA1 algorithm is generally considered stronger than MD5 , but is slower. Select MD5 for minimal security and SHA-1 for maximum security.
SA Life Time (Seconds)	<p>Define the length of time before an IPSec SA automatically renegotiates in this field. It may range from 60 to 3,000,000 seconds (almost 35 days).</p> <p>A short SA Life Time increases security by forcing the two VPN gateways to update the encryption and authentication keys. However, every time the VPN tunnel renegotiates, all users accessing remote resources are temporarily disconnected.</p>
Key Group	You must choose a key group for phase 1 IKE setup. DH1 (default) refers to Diffie-Hellman Group 1 a 768 bit random number. DH2 refers to Diffie-Hellman Group 2 a 1024 bit (1Kb) random number.
Phase 2	
Active Protocol	Use the drop-down list box to choose from ESP or AH .

Table 43 Security > VPN > Setup > Edit > Advanced Setup (continued)

LABEL	DESCRIPTION
Encryption Algorithm	<p>This field is available when you select ESP in the Active Protocol field.</p> <p>Select DES, 3DES, AES or NULL from the drop-down list box.</p> <p>When you use one of these encryption algorithms for data communications, both the sending device and the receiving device must use the same secret key, which can be used to encrypt and decrypt the message or to generate and verify a message authentication code. The DES encryption algorithm uses a 56-bit key. Triple DES (3DES) is a variation on DES that uses a 168-bit key. As a result, 3DES is more secure than DES. It also requires more processing power, resulting in increased latency and decreased throughput. This implementation of AES uses a 128-bit key. AES is faster than 3DES.</p> <p>Select NULL to set up a tunnel without encryption. When you select NULL, you do not enter an encryption key.</p>
Authentication Algorithm	<p>Select SHA1 or MD5 from the drop-down list box. MD5 (Message Digest 5) and SHA1 (Secure Hash Algorithm) are hash algorithms used to authenticate packet data. The SHA1 algorithm is generally considered stronger than MD5, but is slower. Select MD5 for minimal security and SHA-1 for maximum security.</p>
SA Life Time (Seconds)	<p>Define the length of time before an IKE SA automatically renegotiates in this field. It may range from 60 to 3,000,000 seconds (almost 35 days).</p> <p>A short SA Life Time increases security by forcing the two VPN gateways to update the encryption and authentication keys. However, every time the VPN tunnel renegotiates, all users accessing remote resources are temporarily disconnected.</p>
Encapsulation	<p>Select Tunnel mode or Transport mode from the drop-down list box.</p>
Perfect Forward Secrecy (PFS)	<p>Perfect Forward Secrecy (PFS) is disabled (NONE) by default in phase 2 IPsec SA setup. This allows faster IPsec setup, but is not so secure. Choose DH1 or DH2 from the drop-down list box to enable PFS. DH1 refers to Diffie-Hellman Group 1 a 768 bit random number. DH2 refers to Diffie-Hellman Group 2 a 1024 bit (1Kb) random number (more secure, yet slower).</p>
Back	<p>Click Back to return to the previous screen.</p>
Apply	<p>Click Apply to save your changes back to the P-793H v2 and return to the VPN-IKE screen.</p>
Cancel	<p>Click Cancel to return to the VPN-IKE screen without saving your changes.</p>

11.5 Manual Key Setup

Manual key management is useful if you have problems with **IKE** key management.

11.5.1 Security Parameter Index (SPI)

An SPI is used to distinguish different SAs terminating at the same destination and using the same IPSec protocol. This data allows for the multiplexing of SAs to a single gateway. The **SPI** (Security Parameter Index) along with a destination IP address uniquely identify a particular Security Association (SA). The **SPI** is transmitted from the remote VPN gateway to the local VPN gateway. The local VPN gateway then uses the network, encryption and key values that the administrator associated with the SPI to establish the tunnel.

Current ZyxEL implementation assumes identical outgoing and incoming SPIs.

11.6 Configuring Manual Key

You only configure VPN manual key when you select **Manual** in the **IPSec Key Mode** field on the **VPN Setup-Edit** screen. This is the **VPN Setup - Manual Key** screen as shown next.

Figure 74 Security > VPN > Setup > Manual Key

The screenshot shows the 'VPN Setup - Manual Key' configuration page. At the top, there are tabs for 'Setup', 'Monitor', and 'VPN Global Setting'. The main content is organized into sections:

- IPSec Setup:** Includes an 'Active' checkbox, a 'Name' text field, 'IPSec Key Mode' set to 'Manual', 'SPI' set to '0', 'Encapsulation Mode' set to 'Transport', and 'DNS Server (for IPSec VPN)' set to '0.0.0.0'.
- Local:** Includes 'Local Address Type' set to 'Single', 'IP Address Start' set to '0.0.0.0', and 'End / Subnet Mask' set to '0.0.0.0'.
- Remote:** Includes 'Remote Address Type' set to 'Single', 'IP Address Start' set to '0.0.0.0', and 'End / Subnet Mask' set to '0.0.0.0'.
- Address Information:** Includes 'My IP Address' set to '0.0.0.0' and 'Secure Gateway Address' set to '0.0.0.0'.
- Security Protocol:** Includes 'IPSec Protocol' set to 'ESP', 'Encryption Algorithm' set to 'DES', an empty 'Encapsulation Key' field, 'Authentication Algorithm' set to 'SHA1', and an empty 'Authentication Key' field.

At the bottom of the page, there are three buttons: 'Back', 'Apply', and 'Cancel'.

The following table describes the fields in this screen.

Table 44 Security > VPN > Setup > Manual Key

LABEL	DESCRIPTION
IPSec Setup	
Active	Select this check box to activate this VPN policy.
Name	Type up to 32 characters to identify this VPN policy. You may use any character, including spaces, but the P-793H v2 drops trailing spaces.
IPSec Key Mode	Select IKE or Manual from the drop-down list box. Manual is a useful option for troubleshooting if you have problems using IKE key management.
SPI	Type a number (base 10) from 1 to 999999 for the Security Parameter Index.
Encapsulation Mode	Select Tunnel mode or Transport mode from the drop-down list box.
DNS Server (for IPSec VPN)	<p>If there is a private DNS server that services the VPN, type its IP address here. The P-793H v2 assigns this additional DNS server to the P-793H v2 's DHCP clients that have IP addresses in this IPSec rule's range of local addresses.</p> <p>A DNS server allows clients on the VPN to find other computers and servers on the VPN by their (private) domain names.</p>
Local	<p>Local IP addresses must be static and correspond to the remote IPSec router's configured remote IP addresses.</p> <p>Two active SAs cannot have the local and remote IP address(es) both the same. Two active SAs can have the same local or remote IP address, but not both. You can configure multiple SAs between the same local and remote IP addresses, as long as only one is active at any time.</p>
Local Address Type	Use the drop-down menu to choose Single , Range , or Subnet . Select Single for a single IP address. Select Range for a specific range of IP addresses. Select Subnet to specify IP addresses on a network by their subnet mask.
IP Address Start	When the Local Address Type field is configured to Single , enter a (static) IP address on the LAN behind your P-793H v2. When the Local Address Type field is configured to Range , enter the beginning (static) IP address, in a range of computers on your LAN behind your P-793H v2. When the Local Address Type field is configured to Subnet , this is a (static) IP address on the LAN behind your P-793H v2.
End / Subnet Mask	When the Local Address Type field is configured to Single , this field is N/A. When the Local Address Type field is configured to Range , enter the end (static) IP address, in a range of computers on the LAN behind your P-793H v2. When the Local Address Type field is configured to Subnet , this is a subnet mask on the LAN behind your P-793H v2.

Table 44 Security > VPN > Setup > Manual Key (continued)

LABEL	DESCRIPTION
Remote	<p>Remote IP addresses must be static and correspond to the remote IPSec router's configured local IP addresses.</p> <p>Two active SAs cannot have the local and remote IP address(es) both the same. Two active SAs can have the same local or remote IP address, but not both. You can configure multiple SAs between the same local and remote IP addresses, as long as only one is active at any time.</p>
Remote Address Type	Use the drop-down menu to choose Single , Range , or Subnet . Select Single with a single IP address. Select Range for a specific range of IP addresses. Select Subnet to specify IP addresses on a network by their subnet mask.
IP Address Start	When the Remote Address Type field is configured to Single , enter a (static) IP address on the network behind the remote IPSec router. When the Remote Address Type field is configured to Range , enter the beginning (static) IP address, in a range of computers on the network behind the remote IPSec router. When the Remote Address Type field is configured to Subnet , enter a (static) IP address on the network behind the remote IPSec router.
End / Subnet Mask	When the Remote Address Type field is configured to Single , this field is N/A. When the Remote Address Type field is configured to Range , enter the end (static) IP address, in a range of computers on the network behind the remote IPSec router. When the Remote Address Type field is configured to Subnet , enter a subnet mask on the network behind the remote IPSec router.
Address Information	
My IP Address	<p>Enter the WAN IP address of your P-793H v2. The VPN tunnel has to be rebuilt if this IP address changes.</p> <p>The following applies if this field is configured as 0.0.0.0:</p> <p>The P-793H v2 uses the current P-793H v2 WAN IP address (static or dynamic) to set up the VPN tunnel.</p>
Secure Gateway Address	Type the WAN IP address or the URL (up to 31 characters) of the IPSec router with which you're making the VPN connection.
Security Protocol	
IPSec Protocol	Select ESP if you want to use ESP (Encapsulation Security Payload). The ESP protocol (RFC 2406) provides encryption as well as some of the services offered by AH . If you select ESP here, you must select options from the Encryption Algorithm and Authentication Algorithm fields (described next).
Encryption Algorithm	<p>Select DES, 3DES or NULL from the drop-down list box.</p> <p>When DES is used for data communications, both sender and receiver must know the same secret key, which can be used to encrypt and decrypt the message or to generate and verify a message authentication code. The DES encryption algorithm uses a 56-bit key. Triple DES (3DES) is a variation on DES that uses a 168-bit key. As a result, 3DES is more secure than DES. It also requires more processing power, resulting in increased latency and decreased throughput. Select NULL to set up a tunnel without encryption. When you select NULL, you do not enter an encryption key.</p>

Table 44 Security > VPN > Setup > Manual Key (continued)

LABEL	DESCRIPTION
Encapsulation Key (only with ESP)	With DES , type a unique key 8 characters long. With 3DES , type a unique key 24 characters long. Any characters may be used, including spaces, but trailing spaces are truncated.
Authentication Algorithm	Select SHA1 or MD5 from the drop-down list box. MD5 (Message Digest 5) and SHA1 (Secure Hash Algorithm) are hash algorithms used to authenticate packet data. The SHA1 algorithm is generally considered stronger than MD5 , but is slower. Select MD5 for minimal security and SHA-1 for maximum security.
Authentication Key	Type a unique authentication key to be used by IPSec if applicable. Enter 16 characters for MD5 authentication or 20 characters for SHA-1 authentication. Any characters may be used, including spaces, but trailing spaces are truncated.
Back	Click Back to return to the previous screen.
Apply	Click Apply to save your changes back to the P-793H v2.
Cancel	Click Cancel to begin configuring this screen afresh.

11.7 Viewing SA Monitor

Click **Security > VPN > Monitor** to open the screen as shown. Use this screen to display and manage active VPN connections.

A Security Association (SA) is the group of security settings related to a specific VPN tunnel. This screen displays active VPN connections. Use **Refresh** to display active VPN connections. This screen is read-only. The following table describes the fields in this tab.

When there is outbound traffic but no inbound traffic, the SA times out automatically after two minutes. A tunnel with no outbound or inbound traffic is "idle" and does not timeout until the SA lifetime period expires. See [Section](#)

11.9.7 on page 185 on keep alive to have the P-793H v2 renegotiate an IPsec SA when the SA lifetime expires, even if there is no traffic.

Figure 75 Security > VPN > Monitor

No.	Name	Encapsulation	IPsec Algorithm
<input type="radio"/> 1	-	-	-
<input type="radio"/> 2	-	-	-
<input type="radio"/> 3	-	-	-
<input type="radio"/> 4	-	-	-
<input type="radio"/> 5	-	-	-
<input type="radio"/> 6	-	-	-
<input type="radio"/> 7	-	-	-
<input type="radio"/> 8	-	-	-
<input type="radio"/> 9	-	-	-
<input type="radio"/> 10	-	-	-

The following table describes the fields in this screen.

Table 45 Security > VPN > Monitor

LABEL	DESCRIPTION
No	This is the security association index number.
Name	This field displays the identification name for this VPN policy.
Encapsulation	This field displays Tunnel or Transport mode.
IPsec Algorithm	This field displays the security protocol, encryption algorithm, and authentication algorithm used in each VPN tunnel.
Disconnect	Select one of the security associations, and then click Disconnect to stop that security association.
Refresh	Click Refresh to display the current active VPN connection(s).

11.8 Configuring VPN Global Setting

To change your P-793H v2's global settings, click **VPN > VPN Global Setting**. The screen appears as shown.

Figure 76 Security > VPN > Global Setting



The following table describes the fields in this screen.

Table 46 Security > VPN > Global Setting

LABEL	DESCRIPTION
Windows Networking (NetBIOS over TCP/IP)	NetBIOS (Network Basic Input/Output System) are TCP or UDP packets that enable a computer to find other computers. It may sometimes be necessary to allow NetBIOS packets to pass through VPN tunnels in order to allow local computers to find computers on the remote network and vice versa.
Allow NetBIOS Traffic Through All IPsec Tunnels	Select this check box to send NetBIOS packets through the VPN connection.
Apply	Click Apply to save your changes back to the P-793H v2.
Cancel	Click Cancel to begin configuring this screen afresh.

11.9 IPsec VPN Technical Reference

This section provides some technical background information about the topics covered in this chapter.

11.9.1 IPSec Architecture

The overall IPSec architecture is shown as follows.

Figure 77 IPSec Architecture

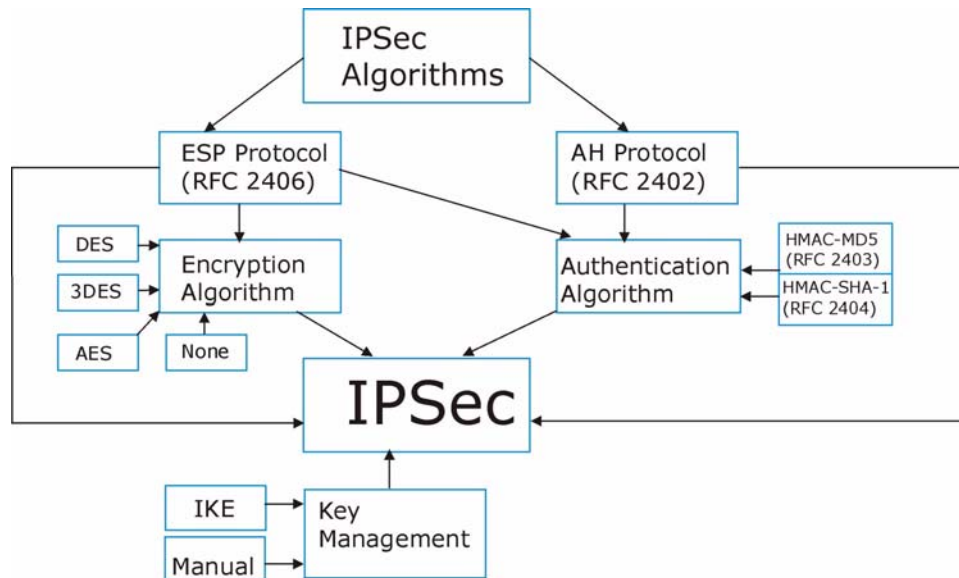

IPSec Algorithms

The **ESP** (Encapsulating Security Payload) Protocol (RFC 2406) and **AH** (Authentication Header) protocol (RFC 2402) describe the packet formats and the default standards for packet structure (including implementation algorithms).

The Encryption Algorithm describes the use of encryption techniques such as DES (Data Encryption Standard) and Triple DES algorithms.

The Authentication Algorithms, HMAC-MD5 (RFC 2403) and HMAC-SHA-1 (RFC 2404), provide an authentication mechanism for the **AH** and **ESP** protocols.

Key Management

Key management allows you to determine whether to use IKE (ISAKMP) or manual key configuration in order to set up a VPN.

11.9.2 IPSec and NAT

Read this section if you are running IPSec on a host computer behind the P-793H v2.

NAT is incompatible with the **AH** protocol in both **Transport** and **Tunnel** mode. An IPSec VPN using the **AH** protocol digitally signs the outbound packet, both data

payload and headers, with a hash value appended to the packet. When using **AH** protocol, packet contents (the data payload) are not encrypted.

A NAT device in between the IPSec endpoints will rewrite either the source or destination address with one of its own choosing. The VPN device at the receiving end will verify the integrity of the incoming packet by computing its own hash value, and complain that the hash value appended to the received packet doesn't match. The VPN device at the receiving end doesn't know about the NAT in the middle, so it assumes that the data has been maliciously altered.

IPSec using **ESP** in **Tunnel** mode encapsulates the entire original packet (including headers) in a new IP packet. The new IP packet's source address is the outbound address of the sending VPN gateway, and its destination address is the inbound address of the VPN device at the receiving end. When using **ESP** protocol with authentication, the packet contents (in this case, the entire original packet) are encrypted. The encrypted contents, but not the new headers, are signed with a hash value appended to the packet.

Tunnel mode **ESP** with authentication is compatible with NAT because integrity checks are performed over the combination of the "original header plus original payload," which is unchanged by a NAT device.

Transport mode **ESP** with authentication is not compatible with NAT.

Table 47 VPN and NAT

SECURITY PROTOCOL	MODE	NAT
AH	Transport	N
AH	Tunnel	N
ESP	Transport	N
ESP	Tunnel	Y

11.9.3 VPN, NAT, and NAT Traversal

NAT is incompatible with the AH protocol in both transport and tunnel mode. An IPSec VPN using the AH protocol digitally signs the outbound packet, both data payload and headers, with a hash value appended to the packet, but a NAT device between the IPSec endpoints rewrites the source or destination address. As a result, the VPN device at the receiving end finds a mismatch between the hash value and the data and assumes that the data has been maliciously altered.

NAT is not normally compatible with ESP in transport mode either, but the P-793H v2's **NAT Traversal** feature provides a way to handle this. NAT traversal allows

you to set up an IKE SA when there are NAT routers between the two IPsec routers.

Figure 78 NAT Router Between IPsec Routers

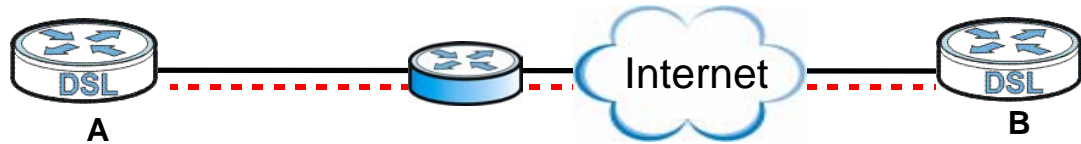

Normally you cannot set up an IKE SA with a NAT router between the two IPsec routers because the NAT router changes the header of the IPsec packet. NAT traversal solves the problem by adding a UDP port 500 header to the IPsec packet. The NAT router forwards the IPsec packet with the UDP port 500 header unchanged. In [Figure 78 on page 182](#), when IPsec router **A** tries to establish an IKE SA, IPsec router **B** checks the UDP port 500 header, and IPsec routers **A** and **B** build the IKE SA.

For NAT traversal to work, you must:

- Use ESP security protocol (in either transport or tunnel mode).
- Use IKE keying mode.
- Enable NAT traversal on both IPsec endpoints.
- Set the NAT router to forward UDP port 500 to IPsec router **A**.

Finally, NAT is compatible with ESP in tunnel mode because integrity checks are performed over the combination of the "original header plus original payload," which is unchanged by a NAT device. The compatibility of AH and ESP with NAT in tunnel and transport modes is summarized in the following table.

Table 48 VPN and NAT

SECURITY PROTOCOL	MODE	NAT
AH	Transport	N
AH	Tunnel	N
ESP	Transport	Y*
ESP	Tunnel	Y

Y* - This is supported in the P-793H v2 if you enable NAT traversal.

11.9.4 Encapsulation

The two modes of operation for IPSec VPNs are **Transport** mode and **Tunnel** mode.

Figure 79 Transport and Tunnel Mode IPSec Encapsulation

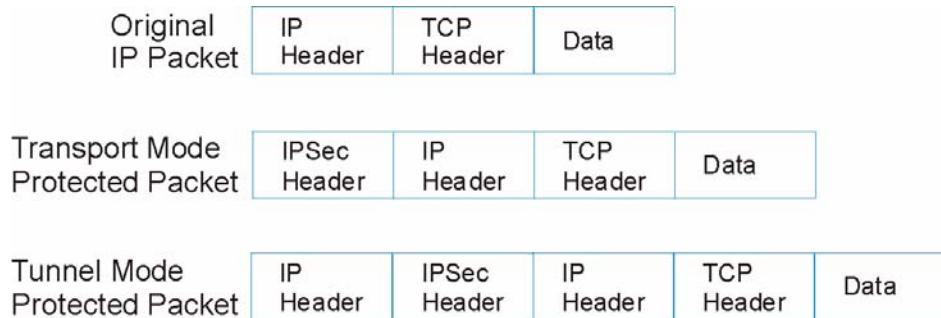

Transport Mode

Transport mode is used to protect upper layer protocols and only affects the data in the IP packet. In **Transport** mode, the IP packet contains the security protocol (**AH** or **ESP**) located after the original IP header and options, but before any upper layer protocols contained in the packet (such as TCP and UDP).

With **ESP**, protection is applied only to the upper layer protocols contained in the packet. The IP header information and options are not used in the authentication process. Therefore, the originating IP address cannot be verified for integrity against the data.

With the use of **AH** as the security protocol, protection is extended forward into the IP header to verify the integrity of the entire packet by use of portions of the original IP header in the hashing process.

Tunnel Mode

Tunnel mode encapsulates the entire IP packet to transmit it securely. A **Tunnel** mode is required for gateway services to provide access to internal systems.

Tunnel mode is fundamentally an IP tunnel with authentication and encryption. This is the most common mode of operation. **Tunnel** mode is required for gateway to gateway and host to gateway communications. **Tunnel** mode communications have two sets of IP headers:

- **Outside header:** The outside IP header contains the destination IP address of the VPN gateway.
- **Inside header:** The inside IP header contains the destination IP address of the final system behind the VPN gateway. The security protocol appears after the outer IP header and before the inside IP header.

11.9.5 IKE Phases

There are two phases to every IKE (Internet Key Exchange) negotiation – phase 1 (Authentication) and phase 2 (Key Exchange). A phase 1 exchange establishes an IKE SA and the second one uses that SA to negotiate SAs for IPSec.

Figure 80 Two Phases to Set Up the IPSec SA

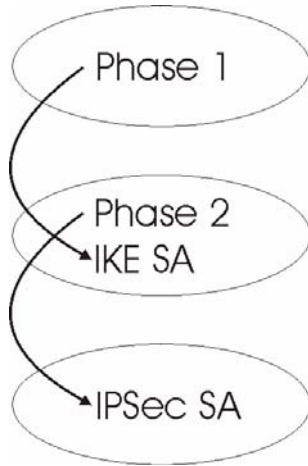

In phase 1 you must:

- Choose a negotiation mode.
- Authenticate the connection by entering a pre-shared key.
- Choose an encryption algorithm.
- Choose an authentication algorithm.
- Choose a Diffie-Hellman public-key cryptography key group (**DH1** or **DH2**).
- Set the IKE SA lifetime. This field allows you to determine how long an IKE SA should stay up before it times out. An IKE SA times out when the IKE SA lifetime period expires. If an IKE SA times out when an IPSec SA is already established, the IPSec SA stays connected.

In phase 2 you must:

- Choose which protocol to use (**ESP** or **AH**) for the IKE key exchange.
- Choose an encryption algorithm.
- Choose an authentication algorithm.
- Choose whether to enable Perfect Forward Secrecy (PFS) using Diffie-Hellman public-key cryptography. Select **None** (the default) to disable PFS.
- Choose **Tunnel** mode or **Transport** mode.

- Set the IPsec SA lifetime. This field allows you to determine how long the IPsec SA should stay up before it times out. The P-793H v2 automatically renegotiates the IPsec SA if there is traffic when the IPsec SA lifetime period expires. The P-793H v2 also automatically renegotiates the IPsec SA if both IPsec routers have keep alive enabled, even if there is no traffic. If an IPsec SA times out, then the IPsec router must renegotiate the SA the next time someone attempts to send traffic.

11.9.6 Negotiation Mode

The phase 1 **Negotiation Mode** you select determines how the Security Association (SA) will be established for each connection through IKE negotiations.

- **Main Mode** ensures the highest level of security when the communicating parties are negotiating authentication (phase 1). It uses 6 messages in three round trips: SA negotiation, Diffie-Hellman exchange and an exchange of nonces (a nonce is a random number). This mode features identity protection (your identity is not revealed in the negotiation).
- **Aggressive Mode** is quicker than **Main Mode** because it eliminates several steps when the communicating parties are negotiating authentication (phase 1). However the trade-off is that faster speed limits its negotiating power and it also does not provide identity protection. It is useful in remote access situations where the address of the initiator is not known by the responder and both parties want to use pre-shared key authentication.

11.9.7 Keep Alive

When you initiate an IPsec tunnel with keep alive enabled, the P-793H v2 automatically renegotiates the tunnel when the IPsec SA lifetime period expires (see [Section 11.9.5 on page 184](#) for more on the IPsec SA lifetime). In effect, the IPsec tunnel becomes an “always on” connection after you initiate it. Both IPsec routers must have a P-793H v2-compatible keep alive feature enabled in order for this feature to work.

If the P-793H v2 has its maximum number of simultaneous IPsec tunnels connected to it and they all have keep alive enabled, then no other tunnels can take a turn connecting to the P-793H v2 because the P-793H v2 never drops the tunnels that are already connected.

When there is outbound traffic with no inbound traffic, the P-793H v2 automatically drops the tunnel after two minutes.

11.9.8 Remote DNS Server

In cases where you want to use domain names to access Intranet servers on a remote network that has a DNS server, you must identify that DNS server. You

cannot use DNS servers on the LAN or from the ISP since these DNS servers cannot resolve domain names to private IP addresses on the remote network

The following figure depicts an example where three VPN tunnels are created from P-793H v2 A; one to branch office 2, one to branch office 3 and another to headquarters. In order to access computers that use private domain names on the headquarters (HQ) network, the P-793H v2 at branch office 1 uses the Intranet DNS server in headquarters. The DNS server feature for VPN does not work with Windows 2000 or Windows XP.

Figure 81 VPN Host using Intranet DNS Server Example

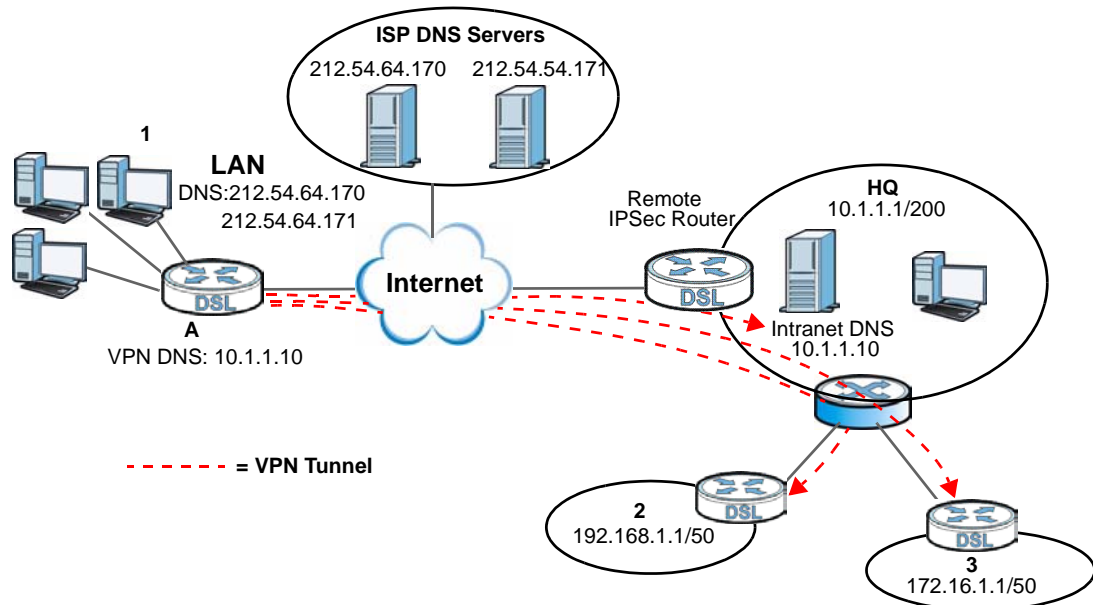

If you do not specify an Intranet DNS server on the remote network, then the VPN host must use IP addresses to access the computers on the remote network.

11.9.9 ID Type and Content

With aggressive negotiation mode (see [Section 11.9.6 on page 185](#)), the P-793H v2 identifies incoming SAs by ID type and content since this identifying information is not encrypted. This enables the P-793H v2 to distinguish between multiple rules for SAs that connect from remote IPSec routers that have dynamic WAN IP addresses. Telecommuters can use separate passwords to simultaneously connect to the P-793H v2 from IPSec routers with dynamic IP addresses (see [Section 11.9.12 on page 188](#) for a telecommuter configuration example).

Regardless of the ID type and content configuration, the P-793H v2 does not allow you to save multiple active rules with overlapping local and remote IP addresses.

With main mode (see [Section 11.9.6 on page 185](#)), the ID type and content are encrypted to provide identity protection. In this case the P-793H v2 can only

distinguish between up to 12 different incoming SAs that connect from remote IPSec routers that have dynamic WAN IP addresses. The P-793H v2 can distinguish up to 12 incoming SAs because you can select between three encryption algorithms (DES, 3DES and AES), two authentication algorithms (MD5 and SHA1) and two key groups (DH1 and DH2) when you configure a VPN rule (see [Section 11.4 on page 171](#)). The ID type and content act as an extra level of identification for incoming SAs.

The type of ID can be a domain name, an IP address or an e-mail address. The content is the IP address, domain name, or e-mail address.

Table 49 Local ID Type and Content Fields

LOCAL ID TYPE=	CONTENT=
IP	Type the IP address of your computer or leave the field blank to have the P-793H v2 automatically use its own IP address.
DNS	Type a domain name (up to 31 characters) by which to identify this P-793H v2.
E-mail	Type an e-mail address (up to 31 characters) by which to identify this P-793H v2.
	The domain name or e-mail address that you use in the Content field is used for identification purposes only and does not need to be a real domain name or e-mail address.

Table 50 Peer ID Type and Content Fields

PEER ID TYPE=	CONTENT=
IP	Type the IP address of the computer with which you will make the VPN connection or leave the field blank to have the P-793H v2 automatically use the address in the Secure Gateway Address field.
DNS	Type a domain name (up to 31 characters) by which to identify the remote IPSec router.
E-mail	Type an e-mail address (up to 31 characters) by which to identify the remote IPSec router.
	The domain name or e-mail address that you use in the Content field is used for identification purposes only and does not need to be a real domain name or e-mail address. The domain name also does not have to match the remote router's IP address or what you configure in the Secure Gateway Address field below.

11.9.9.1 ID Type and Content Examples

Two IPSec routers must have matching ID type and content configuration in order to set up a VPN tunnel.

The two P-793H v2s in this example can complete negotiation and establish a VPN tunnel.

Table 51 Matching ID Type and Content Configuration Example

P-793H V2 A	P-793H V2 B
Local ID type: E-mail	Local ID type: IP
Local ID content: tom@yourcompany.com	Local ID content: 1.1.1.2
Peer ID type: IP	Peer ID type: E-mail
Peer ID content: 1.1.1.2	Peer ID content: tom@yourcompany.com

The two P-793H v2s in this example cannot complete their negotiation because P-793H v2 B's **Local ID type** is **IP**, but P-793H v2 A's **Peer ID type** is set to **E-mail**. An "ID mismatched" message displays in the IPSEC LOG.

Table 52 Mismatching ID Type and Content Configuration Example

P-793H V2 A	P-793H V2 B
Local ID type: IP	Local ID type: IP
Local ID content: 1.1.1.10	Local ID content: 1.1.1.10
Peer ID type: E-mail	Peer ID type: IP
Peer ID content: aa@yahoo.com	Peer ID content: N/A

11.9.10 Pre-Shared Key

A pre-shared key identifies a communicating party during a phase 1 IKE negotiation (see [Section 11.9.5 on page 184](#) for more on IKE phases). It is called "pre-shared" because you have to share it with another party before you can communicate with them over a secure connection.

11.9.11 Diffie-Hellman (DH) Key Groups

Diffie-Hellman (DH) is a public-key cryptography protocol that allows two parties to establish a shared secret over an unsecured communications channel. Diffie-Hellman is used within IKE SA setup to establish session keys. 768-bit (Group 1 - **DH1**) and 1024-bit (Group 2 - **DH2**) Diffie-Hellman groups are supported. Upon completion of the Diffie-Hellman exchange, the two peers have a shared secret, but the IKE SA is not authenticated. For authentication, use pre-shared keys.

11.9.12 Telecommuter VPN/IPSec Examples

The following examples show how multiple telecommuters can make VPN connections to a single P-793H v2 at headquarters. The telecommuters use IPSec routers with dynamic WAN IP addresses. The P-793H v2 at headquarters has a static public IP address.

11.9.12.1 Telecommuters Sharing One VPN Rule Example

See the following figure and table for an example configuration that allows multiple telecommuters (**A**, **B** and **C** in the figure) to use one VPN rule to simultaneously access a P-793H v2 at headquarters (**HQ** in the figure). The telecommuters do not have domain names mapped to the WAN IP addresses of their IPSec routers. The telecommuters must all use the same IPSec parameters but the local IP addresses (or ranges of addresses) should not overlap.

Figure 82 Telecommuters Sharing One VPN Rule Example

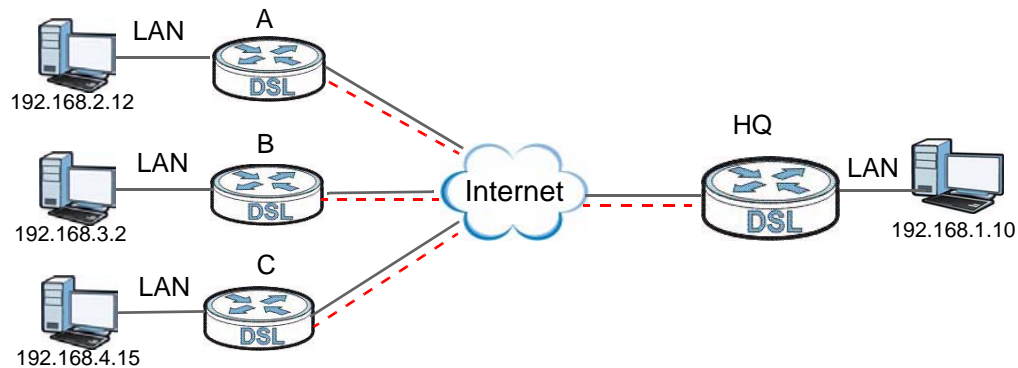

Table 53 Telecommuters Sharing One VPN Rule Example

FIELDS	TELECOMMUTERS	HEADQUARTERS
My IP Address:	0.0.0.0 (dynamic IP address assigned by the ISP)	Public static IP address
Secure Gateway IP Address:	Public static IP address	0.0.0.0 With this IP address only the telecommuter can initiate the IPSec tunnel.
Local IP Address:	Telecommuter A: 192.168.2.12 Telecommuter B: 192.168.3.2 Telecommuter C: 192.168.4.15	192.168.1.10
Remote IP Address:	192.168.1.10	0.0.0.0 (N/A)

11.9.12.2 Telecommuters Using Unique VPN Rules Example

In this example the telecommuters (**A**, **B** and **C** in the figure) use IPSec routers with domain names that are mapped to their dynamic WAN IP addresses (use Dynamic DNS to do this).

With aggressive negotiation mode (see [Section 11.9.6 on page 185](#)), the P-793H v2 can use the ID types and contents to distinguish between VPN rules. Telecommuters can each use a separate VPN rule to simultaneously access a P-793H v2 at headquarters. They can use different IPSec parameters. The local IP addresses (or ranges of addresses) of the rules configured on the P-793H v2 at

headquarters can overlap. The local IP addresses of the rules configured on the telecommuters' IPsec routers should not overlap.

See the following table and figure for an example where three telecommuters each use a different VPN rule for a VPN connection with a P-793H v2 located at headquarters. The P-793H v2 at headquarters (**HQ** in the figure) identifies each incoming SA by its ID type and content and uses the appropriate VPN rule to establish the VPN connection.

The P-793H v2 at headquarters can also initiate VPN connections to the telecommuters since it can find the telecommuters by resolving their domain names.

Figure 83 Telecommuters Using Unique VPN Rules Example

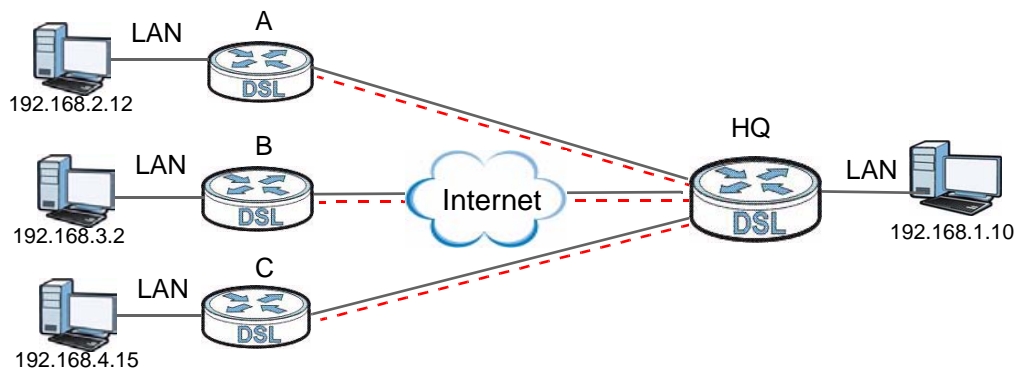

Table 54 Telecommuters Using Unique VPN Rules Example

TELECOMMUTERS	HEADQUARTERS
All Telecommuter Rules:	All Headquarters Rules:
My IP Address 0.0.0.0	My IP Address: bigcompanyhq.com
Secure Gateway Address: bigcompanyhq.com	Local IP Address: 192.168.1.10
Remote IP Address: 192.168.1.10	Local ID Type: E-mail
Peer ID Type: E-mail	Local ID Content: bob@bigcompanyhq.com
Peer ID Content: bob@bigcompanyhq.com	
Telecommuter A (telecommutera.dydns.org)	Headquarters P-793H v2 Rule 1:
Local ID Type: IP	Peer ID Type: IP
Local ID Content: 192.168.2.12	Peer ID Content: 192.168.2.12
Local IP Address: 192.168.2.12	Secure Gateway Address: telecommuter1.com
	Remote Address 192.168.2.12

Table 54 Telecommuters Using Unique VPN Rules Example (continued)

TELECOMMUTERS	HEADQUARTERS
Telecommuter B (telecommuterb.dydns.org)	Headquarters P-793H v2 Rule 2:
Local ID Type: DNS	Peer ID Type: DNS
Local ID Content: telecommuterb.com	Peer ID Content: telecommuterb.com
Local IP Address: 192.168.3.2	Secure Gateway Address: telecommuterb.com
	Remote Address 192.168.3.2
Telecommuter C (telecommuterc.dydns.org)	Headquarters P-793H v2 Rule 3:
Local ID Type: E-mail	Peer ID Type: E-mail
Local ID Content: myVPN@myplace.com	Peer ID Content: myVPN@myplace.com
Local IP Address: 192.168.4.15	Secure Gateway Address: telecommuterc.com
	Remote Address 192.168.4.15

Certificates

12.1 Overview

This chapter describes how your P-793H v2 can use certificates as a means of authenticating clients. It gives background information about public-key certificates and explains how to use them.

A certificate contains the certificate owner's identity and public key. Certificates provide a way to exchange public keys for use in authentication.

Figure 84 Certificates Example

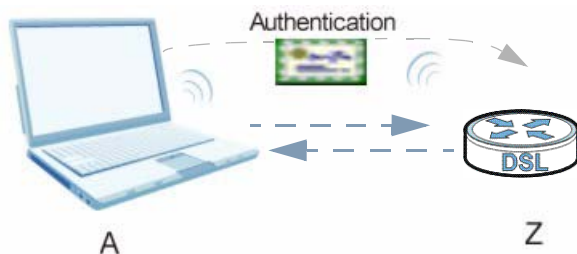

In the figure above, the P-793H v2 (**Z**) checks the identity of the notebook (**A**) using a certificate before granting it access to the network.

12.1.1 What You Need to Know About Certificates

Certification Authority

A Certification Authority (CA) issues certificates and guarantees the identity of each certificate owner. There are commercial certification authorities like CyberTrust or VeriSign and government certification authorities. You can use the P-793H v2 to generate certification requests that contain identifying information and public keys and then send the certification requests to a certification authority.

Certificate File Formats

The certification authority certificate that you want to import has to be in one of these file formats:

- Binary X.509: This is an ITU-T recommendation that defines the formats for X.509 certificates.
- PEM (Base-64) encoded X.509: This Privacy Enhanced Mail format uses lowercase letters, uppercase letters and numerals to convert a binary X.509 certificate into a printable form.

Factory Default Certificate

The P-793H v2 generates its own unique self-signed certificate when you first turn it on. This certificate is referred to in the GUI as the factory default certificate.

12.1.2 Verifying a Certificate

Before you import a trusted certificate into the P-793H v2, you should verify that you have the correct certificate. You can do this using the certificate's fingerprint. A certificate's fingerprint is a message digest calculated using the MD5 or SHA1 algorithm. The following procedure describes how to check a certificate's fingerprint to verify that you have the actual certificate.

- 1 Browse to where you have the certificate saved on your computer.
- 2 Make sure that the certificate has a ".cer" or ".crt" file name extension.

Figure 85 Remote Host Certificates

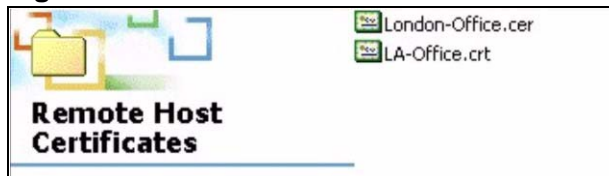

- Double-click the certificate's icon to open the **Certificate** window. Click the **Details** tab and scroll down to the **Thumbprint Algorithm** and **Thumbprint** fields.

Figure 86 Certificate Details

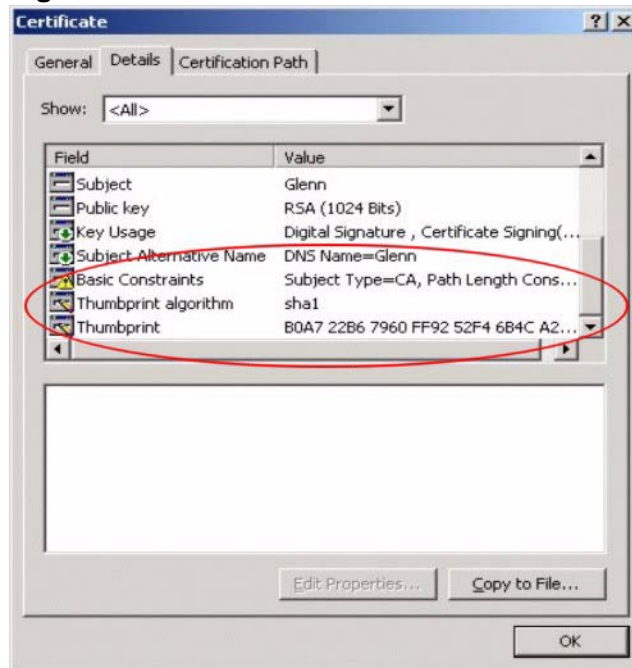

- Use a secure method to verify that the certificate owner has the same information in the **Thumbprint Algorithm** and **Thumbprint** fields. The secure method may vary based on your situation. Possible examples would be over the telephone or through an HTTPS connection.

Finding Out More

See [Section 12.3 on page 200](#) for technical background information on certificates.

12.2 The Trusted CAs Screen

This screen displays a summary list of certificates of the certification authorities that you have set the P-793H v2 to accept as trusted. The P-793H v2 accepts any valid certificate signed by a certification authority on this list as being trustworthy; thus you do not need to import any certificate that is signed by one of these

certification authorities. Click **Security > Certificates > Trusted CAs** to open the following screen.

Figure 87 Trusted CAs



The following table describes the labels in this screen.

Table 55 Trusted CAs

LABEL	DESCRIPTION
PKI Storage Space in Use	This bar displays the percentage of the P-793H v2's PKI storage space that is currently in use. The bar turns from blue to red when the maximum is being approached. When the bar is red, you should consider deleting expired or unnecessary certificates before adding more certificates.
#	This field displays the certificate index number. The certificates are listed in alphabetical order.
Name	This field displays the name used to identify this certificate.
Valid From	This field displays the date that the certificate becomes applicable. The text displays in red and includes a Not Yet Valid! message if the certificate has not yet become applicable.
Valid To	This field displays the date that the certificate expires. The text displays in red and includes an Expiring! or Expired! message if the certificate is about to expire or has already expired.
Modify	Click the Edit icon to open a screen with an in-depth list of information about the certificate. Click the Remove icon to remove the certificate. A window displays asking you to confirm that you want to delete the certificates. Note that subsequent certificates move up by one when you take this action.
Import	Click this to open a screen where you can save the certificate of a certification authority that you trust, from your computer to the P-793H v2.
Refresh	Click this to display the current validity status of the certificates.

12.2.1 Trusted CA Import

Follow the instructions in this screen to save a trusted certification authority's certificate to the P-793H v2. Click **Security** > **Certificates** to open the **Trusted CAs** screen and then click **Import** to open the **Trusted CA Import** screen.

Note: You must remove any spaces from the certificate's filename before you can import the certificate.

Figure 88 Trusted CA Import

The following table describes the labels in this screen.

Table 56 Trusted CA Import

LABEL	DESCRIPTION
File Path	Type in the location of the file you want to upload in this field or click Browse to find it.
Browse	Click this to find the certificate file you want to upload.
Back	Click this to return to the previous screen without saving.
Apply	Click this to save the certificate on the P-793H v2.
Cancel	Click this to restore your previously saved settings.

12.2.2 Trusted CA Details

Use this screen to view in-depth information about the certification authority's certificate, change the certificate's name and set whether or not you want the P-793H v2 to check a certification authority's list of revoked certificates before trusting a certificate issued by the certification authority. Click **Security > Certificates > Trusted CAs** to open the **Trusted CAs** screen. Click the details icon to open the **Trusted CA Details** screen.

Figure 89 Trusted CA Details

Certificates - Trusted CAs - Details

Certificate Name

Certificate Informations

Type	Self-signed X.509 Certificate
Version	V3
Serial Number	0
Signature Algorithm	rsa-pkcs1-md5
Valid From	2007 Jun 18th, 09:20:01 GMT
Valid To	2017 Jun 15th, 09:20:01 GMT
Key Algorithm	rsaEncryption (1024 bits)
MD5 Fingerprint	9f:f8:e2:d5:71:20:e7:03:ca:df:2f:7f:1e:9e:21:46
SHA1 Fingerprint	0d:6f:f2:bd:e1:db:07:cb:63:79:76:60:31:14:a9:08:0b:1b:6f:d3

Certificate in PEM (Base-64) Encoded Format

```
-----BEGIN CERTIFICATE-----
MIIDZTCCAs6gAwIBAgIBADANBgkqhkiG9wOBAQOQFADCBhDELMakGA1UEBhMCQ04x
EDAQOBgNVBAGTBOppYW5nU3UxDTALBgNVBACtBFd1eGkxDjAMBgNVBAoTBVp5WEVM
MQwwCgYDVQQLEwNzdzIxZjEjAQBGNVBAMTCWxvY2FsaG9zdDEiMCAgCSqGSIB3DQEJ
ARYTc2VsaW5hLnN1bkB6eXh1bC5jbjAeFw0wNzA2MTgwOTIwMDFaFw0xNzA2MTUw
OTIwMDFaMIGEMQswCQYDVQQGEwJDTjEQMA4GA1UECBMHSm1hbmdTdTENMAsGA1UE
BxMEV3V4aTEOMAwGA1UEChMFWn1YRUwxDDAKBgNVBAsTA3N3MjESMBAGA1UEAxMJ
bG9jYXVob3N0MSIwIAYJKoZIhvcNAQkBFhNzZWxpbmEuc3VuQHp5eGVsLnNuMIGf
MAOGCSqGSIB3DQEBAA4GNADCBiQKBgQC+2wBNMTNYYwRmGLz1/J3/YTZ/3OCB
yQg2JtkQDf1j3FFuvVTMvvLJTkTEhKuQ7F7XkJ75iFUwTL2vR0nsUIVX3f6Z7Eh
-----
```

The following table describes the labels in this screen.

Table 57 Trusted CA Details

LABEL	DESCRIPTION
Certificate Name	This field displays the identifying name of this certificate. If you want to change the name, type up to 31 characters to identify this key certificate. You may use any character (not including spaces).
Certificate Information	These read-only fields display detailed information about the certificate.
Type	This field displays general information about the certificate. CA-signed means that a Certification Authority signed the certificate. Self-signed means that the certificate's owner signed the certificate (not a certification authority). X.509 means that this certificate was created and signed according to the ITU-T X.509 recommendation that defines the formats for public-key certificates.

Table 57 Trusted CA Details (continued)

LABEL	DESCRIPTION
Version	This field displays the X.509 version number.
Serial Number	This field displays the certificate's identification number given by the certification authority.
Signature Algorithm	This field displays the type of algorithm that was used to sign the certificate. Some certification authorities use rsa-pkcs1-sha1 (RSA public-private key encryption algorithm and the SHA1 hash algorithm). Other certification authorities may use rsa-pkcs1-md5 (RSA public-private key encryption algorithm and the MD5 hash algorithm).
Valid From	This field displays the date that the certificate becomes applicable. The text displays in red and includes a Not Yet Valid! message if the certificate has not yet become applicable.
Valid To	This field displays the date that the certificate expires. The text displays in red and includes an Expiring! or Expired! message if the certificate is about to expire or has already expired.
Key Algorithm	This field displays the type of algorithm that was used to generate the certificate's key pair (the P-793H v2 uses RSA encryption) and the length of the key set in bits (1024 bits for example).
MD5 Fingerprint	This is the certificate's message digest that the P-793H v2 calculated using the MD5 algorithm. You can use this value to verify with the certification authority (over the phone for example) that this is actually their certificate.
SHA1 Fingerprint	This is the certificate's message digest that the P-793H v2 calculated using the SHA1 algorithm. You can use this value to verify with the certification authority (over the phone for example) that this is actually their certificate.
Certificate in PEM (Base-64) Encoded Format	<p>This read-only text box displays the certificate or certification request in Privacy Enhanced Mail (PEM) format. PEM uses 64 ASCII characters to convert the binary certificate into a printable form.</p> <p>You can copy and paste the certificate into an e-mail to send to friends or colleagues or you can copy and paste the certificate into a text editor and save the file on a management computer for later distribution (via floppy disk for example).</p>
Back	Click this to return to the previous screen without saving.
Export	Click this and then Save in the File Download screen. The Save As screen opens, browse to the location that you want to use and click Save .
Apply	Click this to save your changes. You can only change the name and/or set whether or not you want the P-793H v2 to check the CRL that the certification authority issues before trusting a certificate issued by the certification authority.
Cancel	Click this to restore your previously saved settings.

12.3 Certificates Technical Reference

This section provides technical background information about the topics covered in this chapter.

12.3.1 Certificates Overview

The P-793H v2 can use certificates (also called digital IDs) to authenticate users. Certificates are based on public-private key pairs. A certificate contains the certificate owner's identity and public key. Certificates provide a way to exchange public keys for use in authentication.

The P-793H v2 uses certificates based on public-key cryptology to authenticate users attempting to establish a connection, not to encrypt the data that you send after establishing a connection. The method used to secure the data that you send through an established connection depends on the type of connection. For example, a VPN tunnel might use the triple DES encryption algorithm.

The certification authority uses its private key to sign certificates. Anyone can then use the certification authority's public key to verify the certificates.

Advantages of Certificates

Certificates offer the following benefits.

- The P-793H v2 only has to store the certificates of the certification authorities that you decide to trust, no matter how many devices you need to authenticate.
- Key distribution is simple and very secure since you can freely distribute public keys and you never need to transmit private keys.

12.3.2 Private-Public Certificates

When using public-key cryptology for authentication, each host has two keys. One key is public and can be made openly available. The other key is private and must be kept secure.

These keys work like a handwritten signature (in fact, certificates are often referred to as "digital signatures"). Only you can write your signature exactly as it should look. When people know what your signature looks like, they can verify whether something was signed by you, or by someone else. In the same way, your private key "writes" your digital signature and your public key allows people to verify whether data was signed by you, or by someone else. This process works as follows.

- 1 Tim wants to send a message to Jenny. He needs her to be sure that it comes from him, and that the message content has not been altered by anyone else along the way. Tim generates a public key pair (one public key and one private key).
- 2 Tim keeps the private key and makes the public key openly available. This means that anyone who receives a message seeming to come from Tim can read it and verify whether it is really from him or not.
- 3 Tim uses his private key to sign the message and sends it to Jenny.
- 4 Jenny receives the message and uses Tim's public key to verify it. Jenny knows that the message is from Tim, and that although other people may have been able to read the message, no-one can have altered it (because they cannot re-sign the message with Tim's private key).
- 5 Additionally, Jenny uses her own private key to sign a message and Tim uses Jenny's public key to verify the message.

Static Route

13.1 Overview

The P-793H v2 usually uses the default gateway to route outbound traffic from computers on the LAN to the Internet. To have the P-793H v2 send data to devices not reachable through the default gateway, use static routes.

For example, the next figure shows a computer (**A**) connected to the P-793H v2's LAN interface. The P-793H v2 routes most traffic from **A** to the Internet through the P-793H v2's default gateway (**R1**). You create one static route to connect to services offered by your ISP behind router **R2**. You create another static route to communicate with a separate network behind a router **R3** connected to the LAN.

Figure 90 Example of Static Routing Topology

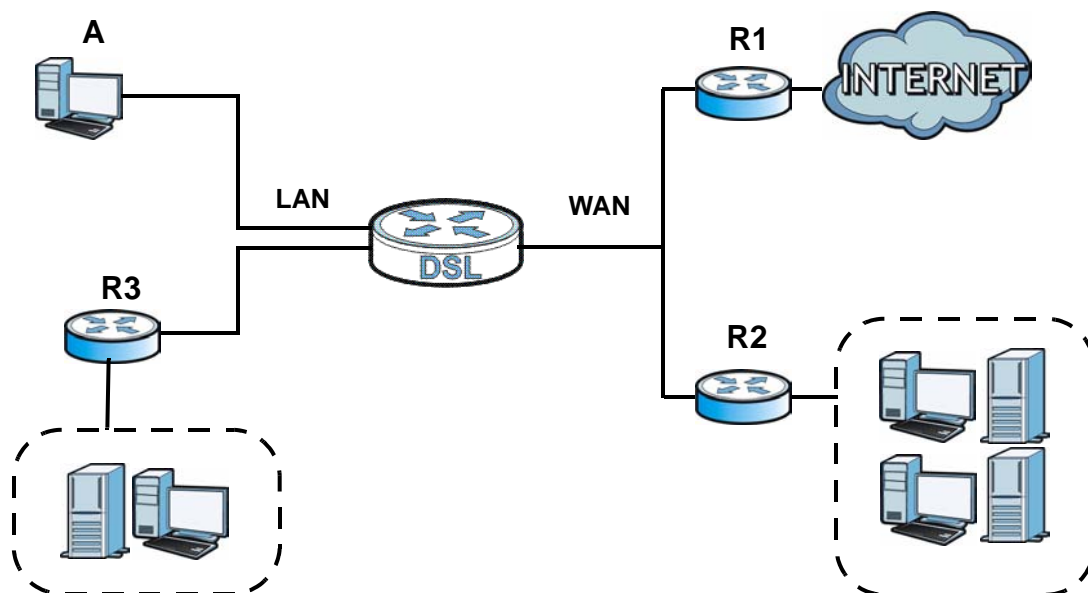

13.2 The Static Route Screen

Use this screen to view the static route rules. Click **Advanced > Static Route** to open the **Static Route** screen.

Figure 91 Advanced > Static Route

#	Active	Name	Destination	Gateway	Subnet Mask	Modify
1	-	-	-	-	-	
2	-	-	-	-	-	
3	-	-	-	-	-	
4	-	-	-	-	-	
5	-	-	-	-	-	
6	-	-	-	-	-	
7	-	-	-	-	-	
8	-	-	-	-	-	
9	-	-	-	-	-	
10	-	-	-	-	-	
11	-	-	-	-	-	
12	-	-	-	-	-	
13	-	-	-	-	-	
14	-	-	-	-	-	
15	-	-	-	-	-	
16	-	-	-	-	-	

The following table describes the labels in this screen.

Table 58 Advanced > Static Route

LABEL	DESCRIPTION
#	This is the number of an individual static route.
Active	This field indicates whether the rule is active or not. Clear the check box to disable the rule. Select the check box to enable it.
Name	This is the name that describes or identifies this route.
Destination	This parameter specifies the IP network address of the final destination. Routing is always based on network number.
Gateway	This is the IP address of the gateway. The gateway is a router or switch on the same network segment as the device's LAN or WAN port. The gateway helps forward packets to their destinations.
Subnet Mask	This parameter specifies the IP network subnet mask of the final destination.
Modify	Click the Edit icon to go to the screen where you can set up a static route on the P-793H v2. Click the Remove icon to remove a static route from the P-793H v2. A window displays asking you to confirm that you want to delete the route.
Apply	Click this to save your changes.
Cancel	Click this to restore your previously saved settings.

13.2.1 Static Route Edit

Use this screen to configure the required information for a static route. Select a static route index number and click **Edit**. The screen shown next appears.

Figure 92 Advanced > Static Route: Edit

The following table describes the labels in this screen.

Table 59 Advanced > Static Route: Edit

LABEL	DESCRIPTION
Active	This field allows you to activate/deactivate this static route.
Route Name	Enter the name of the IP static route. The text may consist of up to 9 letters, numerals and any printable character found on a typical English language keyboard. Leave this field blank to delete this static route.
Destination IP Address	This parameter specifies the IP network address of the final destination. Routing is always based on network number. If you need to specify a route to a single host, use a subnet mask of 255.255.255.255 in the subnet mask field to force the network number to be identical to the host ID.
IP Subnet Mask	Enter the IP subnet mask here.
Gateway Type	Use either Gateway Address or Gateway Node to configure a static route.
Gateway IP Address	Enter the IP address of the gateway. The gateway is a router or switch on the same network segment as the device's LAN or WAN port. The gateway helps forward packets to their destinations.
Gateway Node	This field is available when you select Gateway Node from Gateway Type . Select a remote node to set the static route. A remote node is a connection point outside of the local area network. One example of a remote node is your connection to your ISP.
Back	Click this to return to the previous screen without saving.
Apply	Click this to save your changes.
Cancel	Click this to restore your previously saved settings.

802.1Q/1P

14.1 Overview

This chapter describes how to configure the 802.1Q/1P settings.

A Virtual Local Area Network (VLAN) allows a physical network to be partitioned into multiple logical networks. A VLAN group can be treated as an individual device. Each group can have its own rules about where and how to forward traffic. You can assign any ports on the P-793H v2 to a VLAN group and configure the settings for the group. You may also set the priority level for traffic transmitted through the ports.

Figure 93 802.1Q/1P

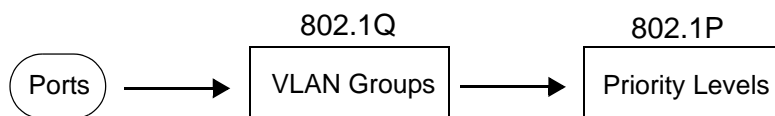

14.1.1 What You Can Do in the 802.1Q/1P Screens

- Use the **Group Setting** screen ([Section 14.2 on page 213](#)) to activate 802.1Q/1P, specify the management VLAN group, display the VLAN groups and configure the settings for each VLAN group.
- Use the **Port Setting** screen ([Section 14.3 on page 215](#)) to configure the PVID and assign traffic priority for each port.

14.1.2 What You Need to Know About 802.1Q/1P

IEEE 802.1P Priority

IEEE 802.1P specifies the user priority field and defines up to eight separate traffic types by inserting a tag into a MAC-layer frame that contains bits to define class of service.

IEEE 802.1Q Tagged VLAN

Tagged VLAN uses an explicit tag (VLAN ID) in the MAC header to identify the VLAN membership of a frame across bridges - they are not confined to the device on which they were created. The VLAN ID associates a frame with a specific VLAN and provides the information that devices need to process the frame across the network.

PVC

A virtual circuit is a logical point-to-point circuit between customer sites. Permanent means that the circuit is preprogrammed by the carrier as a path through the network. It does not need to be set up or torn down for each session.

Forwarding Tagged and Untagged Frames

Each port on the device is capable of passing tagged or untagged frames. To forward a frame from an 802.1Q VLAN-aware device to an 802.1Q VLAN-unaware device, the P-793H v2 first decides where to forward the frame and then strips off the VLAN tag. To forward a frame from an 802.1Q VLAN-unaware device to an 802.1Q VLAN-aware switch, the P-793H v2 first decides where to forward the frame, and then inserts a VLAN tag reflecting the ingress port's default VID. The default PVID is VLAN 1 for all ports, but this can be changed.

Whether to tag an outgoing frame depends on the setting of the egress port on a per-VLAN, per-port basis (recall that a port can belong to multiple VLANs). If the tagging on the egress port is enabled for the VID of a frame, then the frame is transmitted as a tagged frame; otherwise, it is transmitted as an untagged frame.

14.1.3 802.1Q/1P Example

This example shows how to configure the 802.1Q/1P settings on the P-793H v2.

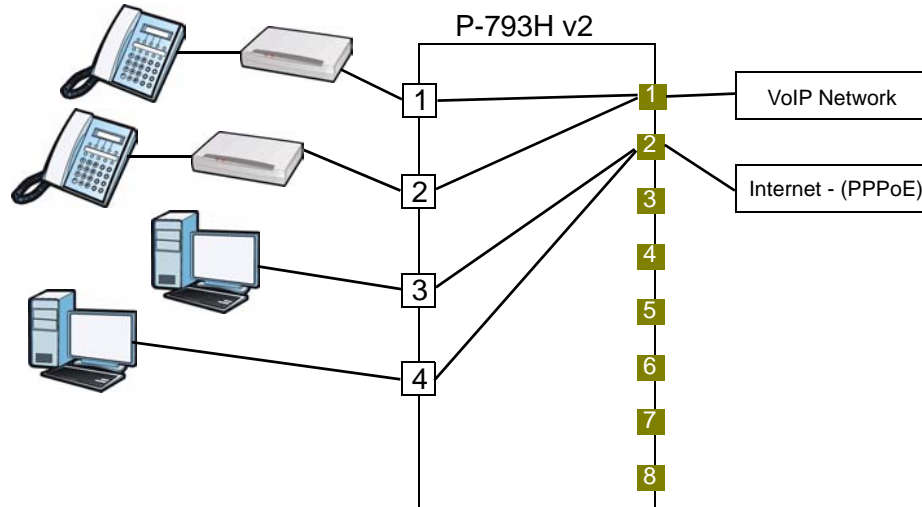

LAN1 and LAN2 are connected to ATAs (Analogue Telephone Adapters) and used for VoIP traffic. You want to create high priority for this type of traffic, so you want to group these ports into one VLAN (VLAN2) and then to a PVC (PVC1) where the priority is set to high level of service.

You would start with the following steps.

- 1 Click **Advanced** > **802.1Q/1P** > **Group Setting**, and then click the **Edit** button to display the following screen.
- 2 In the **Name** field type VoIP to identify the group.
- 3 In the **VLAN ID** field type in 2 to identify the VLAN group.
- 4 Select **PVC1** from the **Default Gateway** drop-down list box.
- 5 In the **Control** field, select **Fixed** for LAN1, LAN2 and PVC1 to be permanent members of the VLAN group.

6 Click **Apply**.

Group Setup

Name

VLAN ID

Default Gateway

Ports	Control		Tx Tag
LAN1	<input checked="" type="radio"/> Fixed	<input type="radio"/> Forbidden	<input type="checkbox"/> Tx Tagging
LAN2	<input checked="" type="radio"/> Fixed	<input type="radio"/> Forbidden	<input type="checkbox"/> Tx Tagging
LAN3	<input type="radio"/> Fixed	<input checked="" type="radio"/> Forbidden	<input type="checkbox"/> Tx Tagging
LAN4	<input type="radio"/> Fixed	<input checked="" type="radio"/> Forbidden	<input type="checkbox"/> Tx Tagging
PVC1	<input checked="" type="radio"/> Fixed	<input type="radio"/> Forbidden	<input type="checkbox"/> Tx Tagging
PVC2	<input type="radio"/> Fixed	<input checked="" type="radio"/> Forbidden	<input type="checkbox"/> Tx Tagging
PVC3	<input type="radio"/> Fixed	<input checked="" type="radio"/> Forbidden	<input type="checkbox"/> Tx Tagging
PVC4	<input type="radio"/> Fixed	<input checked="" type="radio"/> Forbidden	<input type="checkbox"/> Tx Tagging
PVC5	<input type="radio"/> Fixed	<input checked="" type="radio"/> Forbidden	<input type="checkbox"/> Tx Tagging
PVC6	<input type="radio"/> Fixed	<input checked="" type="radio"/> Forbidden	<input type="checkbox"/> Tx Tagging
PVC7	<input type="radio"/> Fixed	<input checked="" type="radio"/> Forbidden	<input type="checkbox"/> Tx Tagging
PVC8	<input type="radio"/> Fixed	<input checked="" type="radio"/> Forbidden	<input type="checkbox"/> Tx Tagging

To set a high priority for VoIP traffic, follow these steps.

- 1 Click **Advanced** > **802.1Q/1P** > **Port Setting** to display the following screen.
- 2 Type **2** in the **802.1Q PVID** column for LAN1, LAN2 and PVC1.
- 3 Select **7** from the **802.1P Priority** drop-down list box for LAN1, LAN2 and PVC1.

4 Click Apply.

The screenshot shows a configuration window with two tabs: "Group Setting" and "Port Setting". The "Port Setting" tab is active. It contains a table with three columns: "Ports", "802.1Q PVID", and "802.1P Priority". The table lists various ports and their corresponding PVID and priority values. At the bottom right of the window, there are "Apply" and "Cancel" buttons.

Ports	802.1Q PVID	802.1P Priority
LAN1	2	7
LAN2	2	7
LAN3	1	Same
LAN4	1	Same
PVC1	2	7
PVC2	1	Same
PVC3	1	Same
PVC4	1	Same
PVC5	1	Same
PVC6	1	Same
PVC7	1	Same
PVC8	1	Same

Ports 3 and 4 are connected to desktop computers and are used for Internet traffic. You want to create low priority for this type of traffic, so you want to group these ports and PVC2 into one VLAN (VLAN3). PVC2 priority is set to low level of service.

Follow the same steps as in VLAN2 to configure the settings for VLAN3. The summary screen should then display as follows.

Group Setting
Port Setting

802.1Q/1P

Active

Management Vlan ID

Summary

#	Name	VID	Port Number								Modify	
			LAN1	LAN3	PVC1	PVC3	PVC5	PVC7				
			LAN2	LAN4	PVC2	PVC4	PVC6	PVC8				
1	Default	1	U	U	U	U	U	U	U	U	U	
2	VoIP	2	U	-	U	-	-	-	-	-	-	
3	Data	3	-	U	-	-	-	-	-	-	-	
4	-	-	-	-	-	-	-	-	-	-	-	
5	-	-	-	-	-	-	-	-	-	-	-	
6	-	-	-	-	-	-	-	-	-	-	-	
7	-	-	-	-	-	-	-	-	-	-	-	
8	-	-	-	-	-	-	-	-	-	-	-	
9	-	-	-	-	-	-	-	-	-	-	-	
10	-	-	-	-	-	-	-	-	-	-	-	
11	-	-	-	-	-	-	-	-	-	-	-	
12	-	-	-	-	-	-	-	-	-	-	-	

This completes the 802.1Q/1P setup.

14.2 The 802.1Q/1P Group Setting Screen

Use this screen to activate 802.1Q/1P and display the VLAN groups. Click **Advanced > 802.1Q/1P** to display the following screen.

Figure 94 Advanced > 802.1Q/1P > Group Setting

Group Setting		Port Setting														
802.1Q/1P																
Active		<input type="checkbox"/>														
Management Vlan ID		<input type="text" value="1"/>														
Summary																
#	Name	VID	Port Number								Modify					
			LAN1	LAN2	LAN3	LAN4	PVC1	PVC2	PVC3	PVC4		PVC5	PVC6	PVC7	PVC8	
1	Default	1	U	U	U	U	U	U	U	U	U	U	U	U		
2	-	-	-	-	-	-	-	-	-	-	-	-	-	-		
3	-	-	-	-	-	-	-	-	-	-	-	-	-	-		
4	-	-	-	-	-	-	-	-	-	-	-	-	-	-		
5	-	-	-	-	-	-	-	-	-	-	-	-	-	-		
6	-	-	-	-	-	-	-	-	-	-	-	-	-	-		
7	-	-	-	-	-	-	-	-	-	-	-	-	-	-		
8	-	-	-	-	-	-	-	-	-	-	-	-	-	-		
9	-	-	-	-	-	-	-	-	-	-	-	-	-	-		
10	-	-	-	-	-	-	-	-	-	-	-	-	-	-		
11	-	-	-	-	-	-	-	-	-	-	-	-	-	-		
12	-	-	-	-	-	-	-	-	-	-	-	-	-	-		

The following table describes the labels in this screen.

Table 60 Advanced > 802.1Q/1P > Group Setting

LABEL	DESCRIPTION
802.1Q/1P	
Active	Select this check box to activate the 802.1P/1Q feature.
Management Vlan ID	Enter the ID number of a VLAN group. All interfaces (ports, SSIDs and PVCs) are in the management VLAN by default. If you disable the management VLAN, you will not be able to access the P-793H v2.
Summary	
#	This field displays the index number of the VLAN group.
Name	This field displays the name of the VLAN group.
VID	This field displays the ID number of the VLAN group.

Table 60 Advanced > 802.1Q/1P > Group Setting (continued)

LABEL	DESCRIPTION
Port Number	These columns display the VLAN's settings for each port. A tagged port is marked as T , an untagged port is marked as U and ports not participating in a VLAN are marked as "–".
Modify	Click the Edit button to configure the ports in the VLAN group. Click the Remove button to delete the VLAN group.
Apply	Click this to save your changes.
Cancel	Click this to restore your previously saved settings.

14.2.1 Editing 802.1Q/1P Group Setting

Use this screen to configure the settings for each VLAN group.

In the **802.1Q/1P** screen, click the **Edit** button from the **Modify** filed to display the following screen.

Figure 95 Advanced > 802.1Q/1P > Group Setting > Edit

The following table describes the labels in this screen.

Table 61 Advanced > 802.1Q/1P > Group Setting > Edit

LABEL	DESCRIPTION
Name	Enter a descriptive name for the VLAN group for identification purposes. The text may consist of up to 8 letters, numerals, "-", "_", and "@".
VLAN ID	Assign a VLAN ID for the VLAN group. The valid VID range is between 1 and 4094.

Table 61 Advanced > 802.1Q/1P > Group Setting > Edit (continued)

LABEL	DESCRIPTION
Default Gateway	Select the default gateway for the VLAN group.
Ports	This field displays the types of ports available to join the VLAN group.
Control	Select Fixed for the port to be a permanent member of the VLAN group. Select Forbidden if you want to prohibit the port from joining the VLAN group.
Tx Tag	Select Tx Tagging if you want the port to tag all outgoing traffic transmitted through this VLAN. You select this if you want to create VLANs across different devices and not just the P-793H v2.
Back	Click this to return to the previous screen without saving.
Apply	Click this to save your changes.
Cancel	Click this to restore your previously saved settings.

14.3 The 802.1Q/1P Port Setting Screen

Use this screen to configure the PVID and assign traffic priority for each port. Click **Advanced > 802.1Q/1P > Port Setting** to display the following screen.

Figure 96 Advanced > 802.1Q/1P > Port Setting

Ports	802.1Q PVID	802.1P Priority
LAN1	1	Same
LAN2	1	Same
LAN3	1	Same
LAN4	1	Same
PVC1	1	Same
PVC2	1	Same
PVC3	1	Same
PVC4	1	Same
PVC5	1	Same
PVC6	1	Same
PVC7	1	Same
PVC8	1	Same

Apply Cancel

The following table describes the labels in this screen.

Table 62 Advanced > 802.1Q/1P > Port Setting

LABEL	DESCRIPTION
Ports	This field displays the types of ports available to join the VLAN group.
802.1Q PVID	Assign a VLAN ID for the port. The valid VID range is between 1 and 4094. The P-793H v2 assigns the PVID to untagged frames or priority-tagged frames received on this port.
802.1P Priority	Assign a priority for the traffic transmitted through the port. Select Same if you do not want to modify the priority. You may choose a priority level from 0-7 , with 0 being the lowest level and 7 being the highest level.
Apply	Click this to save your changes.
Cancel	Click this to restore your previously saved settings.

Quality of Service (QoS)

15.1 Overview

Use the **QoS** screens to set up your P-793H v2 to use QoS for traffic management.

Quality of Service (QoS) refers to both a network's ability to deliver data with minimum delay, and the networking methods used to control bandwidth. QoS allows the P-793H v2 to group and prioritize application traffic and fine-tune network performance.

Without QoS, all traffic data are equally likely to be dropped when the network is congested. This can cause a reduction in network performance and make the network inadequate for time-critical applications such as video-on-demand.

The P-793H v2 assigns each packet a priority and then queues the packet accordingly. Packets assigned with a high priority are processed more quickly than those with low priorities if there is congestion, allowing time-sensitive applications to flow more smoothly. Time-sensitive applications include both those that require a low level of latency (delay) and a low level of jitter (variations in delay) such as Voice over IP (VoIP) or Internet gaming, and those for which jitter alone is a problem such as Internet radio or streaming video.

15.2 QoS Overview

The following figure gives an overview of how to configure QoS on this P-793H v2:

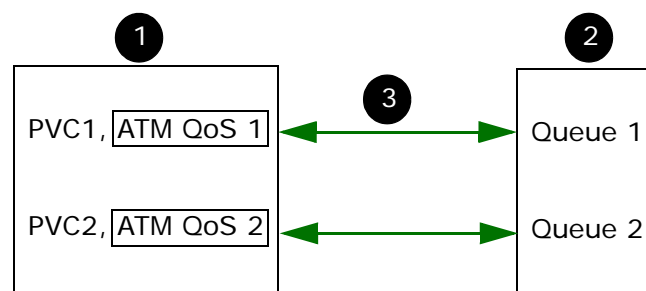

- 1 First, you have to configure WAN connection(s) in **Network > WAN > Internet Access Setup** and **Network > WAN > More Connections**. Click the **Advanced Setup** button on the corresponding PVC setting screens to configure ATM QoS, if you want to prioritize traffic and eliminate congestion over the ATM network (at the ATM layer).
- 2 Configure queue settings in **Advanced > QoS > Queue Setup** according to the priority you want to apply to different types of traffic.
- 3 Configure class settings in **Advanced > QoS > Class Setup**. This associates queues with PVCs by mapping the priority of queues to the index number of PVCs.

15.2.1 What You Can Do in the QoS Screens

- Use the **General** screen ([Section 15.3 on page 223](#)) to enable QoS on the P-793H v2, decide allowable bandwidth using QoS and configure priority mapping settings for traffic that does not match a custom class.
- Use the **Class Setup** screen ([Section 15.4 on page 224](#)) to set up classifiers to sort traffic into different flows and assign priority and define actions to be performed for a classified traffic flow.
- Use the **Monitor** screen ([Section 15.5 on page 230](#)) to view the P-793H v2's QoS-related packet statistics.

15.2.2 What You Need to Know About QoS

QoS versus Cos

QoS is used to prioritize source-to-destination traffic flows. All packets in the same flow are given the same priority. Class of Service (CoS) is a way of managing traffic in a network by grouping similar types of traffic together and treating each type as a class. You can use CoS to give different priorities to different packet types.

CoS technologies include IEEE 802.1p layer 2 tagging and Differentiated Services (DiffServ or DS). IEEE 802.1p tagging makes use of three bits in the packet header, while DiffServ is a new protocol and defines a new DS field, which replaces the eight-bit Type of Service (ToS) field in the IP header.

Tagging and Marking

In a QoS class, you can configure whether to add or change the DiffServ Code Point (DSCP) value, IEEE 802.1p priority level and VLAN ID number in a matched packet. When the packet passes through a compatible network, the networking device, such as a backbone switch, can provide specific treatment or service based on the tag or marker.

Finding Out More

See [Section 15.6 on page 231](#) for advanced technical information on QoS.

15.2.3 QoS Class Setup Example

In the following figure, your Internet connection has an upstream transmission speed of 50 Mbps. You configure a classifier to assign the highest priority queue (6) to VoIP traffic from the LAN interface, so that voice traffic would not get delayed when there is network congestion. Traffic from the boss's IP address (192.168.1.23 for example) is mapped to queue 5. Traffic that does not match

these two classes are assigned priority queue based on the internal QoS mapping table on the P-793H v2.

Figure 97 QoS Example

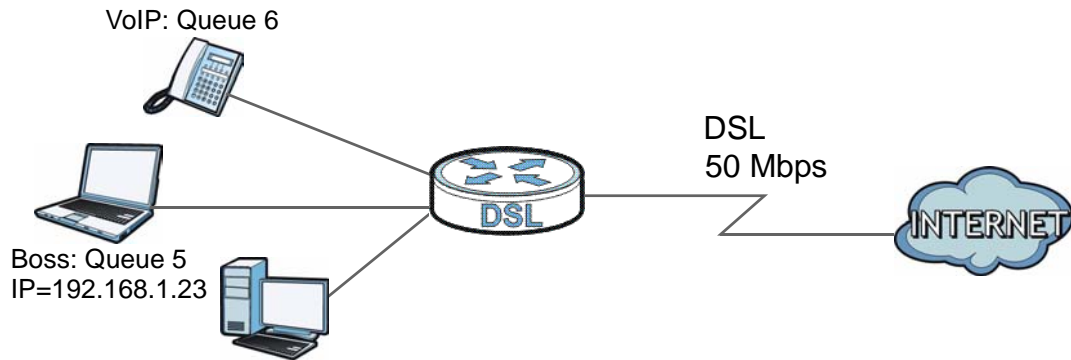

Figure 98 QoS Class Example: VoIP -1

The screenshot shows the 'Class Configuration' interface for a VoIP class. The 'Active' checkbox is checked. The Name is 'Ex_VoIP', Interface is 'From LAN', Priority is '6', Routing Policy is 'By Routing Table', WAN Index is '1', Gateway Address is '0.0.0.0', and Order is '1'. The 'Tag Configuration' section is visible at the bottom.

Figure 99 QoS Class Example: VoIP -2

Source:

Address: 0.0.0.0 Subnet Netmask: 0.0.0.0 Exclude

Port: 0 ~ 0 Exclude

MAC: 00:00:00:00:00:00 MAC Mask: 00:00:00:00:00:00 Exclude

Destination

Address: 0.0.0.0 Subnet Netmask: 0.0.0.0 Exclude

Port: 0 ~ 0 Exclude

MAC: 00:00:00:00:00:00 MAC Mask: 00:00:00:00:00:00 Exclude

Others

Service: VoIP(SIP)

Protocol: TCP 0 Exclude

Packet Length: 0 ~ 0 Exclude

DSCP: 0 (0~63) Exclude

Ethernet Priority: 0-BE Exclude

VLAN ID: 2 (2~4094) Exclude

Physical Port: 1 Exclude

Remote Node: WAN1 Exclude

Back Apply Cancel

Figure 100 QoS Class Example: Boss -1

Class Configuration

Active

Name: Ex_Boss

Interface: From LAN

Priority: 5

Routing Policy: By Routing Table

- WAN Index: 1

- Gateway Address: 0.0.0.0

Order: 2

Tag Configuration

Figure 101 QoS Class Example: Boss -2

File Configuration

Source:

<input checked="" type="checkbox"/> Address	192.168.1.23	Subnet Netmask	255.255.255.0	<input type="checkbox"/> Exclude
<input type="checkbox"/> Port	0 ~ 0			<input type="checkbox"/> Exclude
<input type="checkbox"/> MAC	00:00:00:00:00:00	MAC Mask	00:00:00:00:00:00	<input type="checkbox"/> Exclude

Destination

<input type="checkbox"/> Address	0.0.0.0	Subnet Netmask	0.0.0.0	<input type="checkbox"/> Exclude
<input type="checkbox"/> Port	0 ~ 0			<input type="checkbox"/> Exclude
<input type="checkbox"/> MAC	00:00:00:00:00:00	MAC Mask	00:00:00:00:00:00	<input type="checkbox"/> Exclude

Others

<input type="checkbox"/> Service	FTP			
<input type="checkbox"/> Protocol	TCP	0	<input type="checkbox"/> Exclude	
<input type="checkbox"/> Packet Length	0 ~ 0		<input type="checkbox"/> Exclude	
<input type="checkbox"/> DSCP	0 (0~63)		<input type="checkbox"/> Exclude	
<input type="checkbox"/> Ethernet Priority	0-BE		<input type="checkbox"/> Exclude	
<input type="checkbox"/> VLAN ID	2 (2~4094)		<input type="checkbox"/> Exclude	
<input type="checkbox"/> Physical Port	1		<input type="checkbox"/> Exclude	
<input type="checkbox"/> Remote Node	WAN1		<input type="checkbox"/> Exclude	

Back Apply Cancel

15.3 The QoS General Screen

Use this screen to enable or disable QoS and have the P-793H v2 automatically assign priority to traffic according to the IEEE 802.1p priority level, IP precedence and/or packet length.

Click **Advanced > QoS** to open the screen as shown next.

Figure 102 Advanced > QoS > General

The following table describes the labels in this screen.

Table 63 Advanced > QoS > General

LABEL	DESCRIPTION
Active QoS	<p>Select the check box to turn on QoS to improve your network performance.</p> <p>You can give priority to traffic that the P-793H v2 forwards out through the WAN interface. Give high priority to voice and video to make them run more smoothly. Similarly, give low priority to many large file downloads so that they do not reduce the quality of other applications.</p>
WAN Managed Bandwidth	<p>Enter the amount of bandwidth for the WAN interface that you want to allocate using QoS.</p> <p>The recommendation is to set this speed to match the interface's actual transmission speed. For example, set the WAN interface speed to 100000 kbps if your Internet connection has an upstream transmission speed of 100 Mbps.</p> <p>You can set this number higher than the interface's actual transmission speed. This will stop lower priority traffic from being sent if higher priority traffic uses all of the actual bandwidth.</p> <p>You can also set this number lower than the interface's actual transmission speed. This will cause the P-793H v2 to not use some of the interface's available bandwidth.</p>

Table 63 Advanced > QoS > General

LABEL	DESCRIPTION
Traffic priority will be automatically assigned by	<p>These fields are ignored if traffic matches a class you configured in the Class Setup screen.</p> <p>If you select ON and traffic does not match a class configured in the Class Setup screen, the P-793H v2 assigns priority to unmatched traffic based on the IEEE 802.1p priority level, IP precedence and/or packet length. See Section 15.6.4 on page 232 for more information.</p> <p>If you select OFF, traffic which does not match a class is mapped to queue two.</p>
Apply	Click this to save your changes.
Cancel	Click this to restore your previously saved settings.

15.4 The Class Setup Screen

Use this screen to add, edit or delete classifiers. A classifier groups traffic into data flows according to specific criteria such as the source address, destination address, source port number, destination port number or incoming interface. For example, you can configure a classifier to select traffic from the same protocol port (such as Telnet) to form a flow.

Click **Advanced > QoS > Class Setup** to open the following screen.

Figure 103 Advanced > QoS > Class Setup

No	Active	Name	Interface	Priority	Filter Content	Modify
1	<input checked="" type="checkbox"/>	Default	From LAN	2	Match any packets	

The following table describes the labels in this screen.

Table 64 Advanced > QoS > Class Setup

LABEL	DESCRIPTION
Create a new Class	Click Add to create a new classifier.
No	This is the number of each classifier. The ordering of the classifiers is important as the classifiers are applied in turn.
Active	Select the check box to enable this classifier.
Name	This is the name of the classifier.

Table 64 Advanced > QoS > Class Setup (continued)

LABEL	DESCRIPTION
Interface	This shows the interface from which traffic of this classifier should come.
Priority	This is the priority assigned to traffic of this classifier.
Filter Content	This shows criteria specified in this classifier.
Modify	Click the Edit icon to go to the screen where you can edit the classifier. Click the Remove icon to delete an existing classifier.
Apply	Click this to save your changes.
Cancel	Click this to restore your previously saved settings.

15.4.1 The Class Configuration Screen

Use this screen to configure a classifier. Click the **Add** button or the **Edit** icon in the **Modify** field to display the following screen.

Figure 104 Advanced > QoS > Class Setup: Edit

<input checked="" type="checkbox"/> Active	Name:	Default	
	Interface	From LAN	
	Priority	2 (Default)	
	Routing Policy	By Routing Table	
	- WAN Index	1	
	- Gateway Address	0.0.0.0	
	Order	2	

Tag Configuration			
DSCP Value	Same	0	(0~63)
802.1Q Tag	Same		
- Ethernet Priority	0-BE		
- VLAN ID	2		(2~4094)

Filter Configuration			
Source			
<input type="checkbox"/> Address	0.0.0.0	Subnet Netmask	0.0.0.0 <input type="checkbox"/> Exclude
<input type="checkbox"/> Port	0 ~ 0		<input type="checkbox"/> Exclude
<input type="checkbox"/> MAC	00:00:00:00:00:00	MAC Mask	00:00:00:00:00:00 <input type="checkbox"/> Exclude
Destination			
<input type="checkbox"/> Address	0.0.0.0	Subnet Netmask	0.0.0.0 <input type="checkbox"/> Exclude
<input type="checkbox"/> Port	0 ~ 0		<input type="checkbox"/> Exclude
<input type="checkbox"/> MAC	00:00:00:00:00:00	MAC Mask	00:00:00:00:00:00 <input type="checkbox"/> Exclude
Others			
<input type="checkbox"/> Service	FTP		
<input type="checkbox"/> Protocol	TCP	0	<input type="checkbox"/> Exclude
<input type="checkbox"/> Packet Length	0 ~ 0		<input type="checkbox"/> Exclude
<input type="checkbox"/> DSCP	0	(0~63)	<input type="checkbox"/> Exclude
<input type="checkbox"/> Ethernet Priority	0-BE		<input type="checkbox"/> Exclude
<input type="checkbox"/> VLAN ID	2	(2~4094)	<input type="checkbox"/> Exclude
<input type="checkbox"/> Physical Port	1		<input type="checkbox"/> Exclude
<input type="checkbox"/> Remote Node	WAN1		<input type="checkbox"/> Exclude

See [Appendix F on page 473](#) for a list of commonly-used services. The following table describes the labels in this screen.

Table 65 Advanced > QoS > Class Setup: Edit

LABEL	DESCRIPTION
Class Configuration	
Active	Select the check box to enable this classifier.
Name	The text may consist of up to 20 letters, numerals and any printable character found on a typical English language keyboard.
Interface	Select from which interface traffic of this class should come.
Priority	Select a priority level (between 0 and 7) or select Auto to have the P-793H v2 map the matched traffic to a queue according to the internal QoS mapping table. See Section 15.6.4 on page 232 for more information. "0" is the lowest priority level and "7" is the highest.
Routing Policy	Select the next hop to which traffic of this class should be forwarded. Select By Routing Table to have the P-793H v2 use the routing table to find a next hop and forward the matched packets automatically. Select To WAN Index to route the matched packets through the specified PVC. This option is available only when the WAN type is ADSL. Select To Gateway Address to route the matched packets to the router or switch you specified in the Gateway Address field.
WAN Index	Select a PVC index number.
Gateway Address	Enter the IP address of the gateway, which should be a router or switch on the same segment as the P-793H v2's interface(s), that can forward the packet to the destination.
Order	This shows the ordering number of this classifier. Select an existing number for where you want to put this classifier and click Apply to move the classifier to the number you selected. For example, if you select 2, the classifier you are moving becomes number 2 and the previous classifier 2 gets pushed down one.
Tag Configuration	
DSCP Value	Select Same to keep the DSCP fields in the packets. Select Auto to map the DSCP value to 802.1 priority level automatically. Select Mark to set the DSCP field with the value you configure in the field provided.

Table 65 Advanced > QoS > Class Setup: Edit (continued)

LABEL	DESCRIPTION
802.1Q Tag	<p>Select Same to keep the priority setting and VLAN ID of the frames.</p> <p>Select Auto to map the 802.1 priority level to the DSCP value automatically.</p> <p>Select Remove to delete the priority queue tag and VLAN ID of the frames.</p> <p>Select Mark to replace the 802.1 priority field and VLAN ID with the value you set in the fields below.</p> <p>Select Add to treat all matched traffic untagged and add a second priority queue tag and VLAN.</p>
Ethernet Priority	Select a priority level (between 0 and 7) from the drop down list box.
VLAN ID	Specify a VLAN ID number between 2 and 4094.
Filter Configuration	Use the following fields to configure the criteria for traffic classification.
Source	
Address	Select the check box and enter the source IP address in dotted decimal notation. A blank source IP address means any source IP address.
Subnet Netmask	Enter the source subnet mask. Refer to the appendix for more information on IP subnetting.
Port	Select the check box and enter the port number of the source. 0 means any source port number. See Appendix F on page 473 for some common services and port numbers.
MAC	Select the check box and enter the source MAC address of the packet.
MAC Mask	<p>Type the mask for the specified MAC address to determine which bits a packet's MAC address should match.</p> <p>Enter "f" for each bit of the specified source MAC address that the traffic's MAC address should match. Enter "0" for the bit(s) of the matched traffic's MAC address, which can be of any hexadecimal character(s). For example, if you set the MAC address to 00:13:49:00:00:00 and the mask to ff:ff:ff:00:00:00, a packet with a MAC address of 00:13:49:12:34:56 matches this criteria.</p>
Exclude	Select this option to exclude the packets that match the specified criteria from this classifier.
Destination	
Address	Select the check box and enter the destination IP address in dotted decimal notation.
Subnet Netmask	Enter the destination subnet mask. Refer to the appendix for more information on IP subnetting.
Port	Select the check box and enter the port number of the destination. 0 means any source port number. See Appendix F on page 473 for some common services and port numbers.
MAC	Select the check box and enter the destination MAC address of the packet.

Table 65 Advanced > QoS > Class Setup: Edit (continued)

LABEL	DESCRIPTION
MAC Mask	Type the mask for the specified MAC address to determine which bits a packet's MAC address should match. Enter "f" for each bit of the specified destination MAC address that the traffic's MAC address should match. Enter "0" for the bit(s) of the matched traffic's MAC address, which can be of any hexadecimal character(s). For example, if you set the MAC address to 00:13:49:00:00:00 and the mask to ff:ff:ff:00:00:00, a packet with a MAC address of 00:13:49:12:34:56 matches this criteria.
Exclude	Select this option to exclude the packets that match the specified criteria from this classifier.
Others	
Service	This field simplifies classifier configuration by allowing you to select a predefined application. When you select a predefined application, you do not configure the rest of the filter fields. SIP (Session Initiation Protocol) is a signaling protocol used in Internet telephony, instant messaging and other VoIP (Voice over IP) applications. Select the check box and select VoIP(SIP) from the drop-down list box to configure this classifier for traffic that uses SIP. File Transfer Protocol (FTP) is an Internet file transfer service that operates on the Internet and over TCP/IP networks. A system running the FTP server accepts commands from a system running an FTP client. The service allows users to send commands to the server for uploading and downloading files. Select the check box and select FTP from the drop-down list box to configure this classifier for FTP traffic.
Protocol	Select this option and select the protocol (TCP or UDP) or select User defined and enter the protocol (service type) number. 0 means any protocol number.
Packet Length	Select this option and enter the minimum and maximum packet length (from 28 to 1500) in the fields provided.
DSCP	Select this option and specify a DSCP (DiffServ Code Point) number between 0 and 63 in the field provided.
Ethernet Priority	Select this option and select a priority level (between 0 and 7) from the drop down list box. "0" is the lowest priority level and "7" is the highest.
VLAN ID	Select this option and specify a VLAN ID number between 2 and 4094.
Physical Port	Select this option and select a LAN port.
Remote Node	Select this option and select a remote node from the drop down list box. When the WAN type is Ethernet in the WAN > Internet Access Setup screen, you can select WAN1 only.
Exclude	Select this option to exclude the packets that match the specified criteria from this classifier.
Back	Click this to return to the previous screen without saving.
Apply	Click this to save your changes.
Cancel	Click this to restore your previously saved settings.

15.5 The QoS Monitor Screen

Use this screen to view the P-793H v2's QoS packet statistics. Click **Advanced > QoS > Monitor**. The screen appears as shown.

Figure 105 Advanced > QoS > Monitor

Priority Queue	Pass	Drop
0	0 bps	0 bps
1	0 bps	0 bps
2	0 bps	0 bps
3	0 bps	0 bps
4	0 bps	0 bps
5	0 bps	0 bps
6	0 bps	0 bps
7	0 bps	0 bps

Poll Interval(s) : sec

The following table describes the labels in this screen.

Table 66 Advanced > QoS > Monitor

LABEL	DESCRIPTION
Priority Queue	This shows the priority queue number. Traffic assigned to higher index queues gets through faster while traffic in lower index queues is dropped if the network is congested.
Pass	This shows how many packets mapped to this priority queue are transmitted successfully.
Drop	This shows how many packets mapped to this priority queue are dropped.
Poll Interval(s)	Enter the time interval for refreshing statistics in this field.
Set Interval	Click this to apply the new poll interval you entered in the Poll Interval(s) field.
Stop	Click this to stop refreshing statistics.

15.6 QoS Technical Reference

This section provides some technical background information about the topics covered in this chapter.

15.6.1 IEEE 802.1Q Tag

The IEEE 802.1Q standard defines an explicit VLAN tag in the MAC header to identify the VLAN membership of a frame across bridges. A VLAN tag includes the 12-bit VLAN ID and 3-bit user priority. The VLAN ID associates a frame with a specific VLAN and provides the information that devices need to process the frame across the network.

IEEE 802.1p specifies the user priority field and defines up to eight separate traffic types. The following table describes the traffic types defined in the IEEE 802.1d standard (which incorporates the 802.1p).

Table 67 IEEE 802.1p Priority Level and Traffic Type

PRIORITY LEVEL	TRAFFIC TYPE
Level 7	Typically used for network control traffic such as router configuration messages.
Level 6	Typically used for voice traffic that is especially sensitive to jitter (jitter is the variations in delay).
Level 5	Typically used for video that consumes high bandwidth and is sensitive to jitter.
Level 4	Typically used for controlled load, latency-sensitive traffic such as SNA (Systems Network Architecture) transactions.
Level 3	Typically used for "excellent effort" or better than best effort and would include important business traffic that can tolerate some delay.
Level 2	This is for "spare bandwidth".
Level 1	This is typically used for non-critical "background" traffic such as bulk transfers that are allowed but that should not affect other applications and users.
Level 0	Typically used for best-effort traffic.

15.6.2 IP Precedence

Similar to IEEE 802.1p prioritization at layer-2, you can use IP precedence to prioritize packets in a layer-3 network. IP precedence uses three bits of the eight-bit ToS (Type of Service) field in the IP header. There are eight classes of services (ranging from zero to seven) in IP precedence. Zero is the lowest priority level and seven is the highest.

15.6.3 DiffServ

QoS is used to prioritize source-to-destination traffic flows. All packets in the flow are given the same priority. You can use CoS (class of service) to give different priorities to different packet types.

Differentiated Services (DiffServ) is a Class of Service (CoS) model that marks packets so that they receive specific per-hop treatment at DiffServ-compliant network devices along the route based on the application types and traffic flow. Packets are marked with DiffServ Code Points (DSCPs) indicating the level of service desired. This allows the intermediary DiffServ-compliant network devices to handle the packets differently depending on the code points without the need to negotiate paths or remember state information for every flow. In addition, applications do not have to request a particular service or give advanced notice of where the traffic is going.

DSCP and Per-Hop Behavior

DiffServ defines a new Differentiated Services (DS) field to replace the Type of Service (TOS) field in the IP header. The DS field contains a 2-bit unused field and a 6-bit DSCP field which can define up to 64 service levels. The following figure illustrates the DS field.

DSCP is backward compatible with the three precedence bits in the ToS octet so that non-DiffServ compliant, ToS-enabled network device will not conflict with the DSCP mapping.

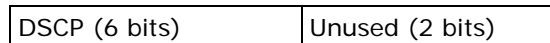

The DSCP value determines the forwarding behavior, the PHB (Per-Hop Behavior), that each packet gets across the DiffServ network. Based on the marking rule, different kinds of traffic can be marked for different kinds of forwarding. Resources can then be allocated according to the DSCP values and the configured policies.

15.6.4 Automatic Priority Queue Assignment

If you enable QoS on the P-793H v2, the P-793H v2 can automatically base on the IEEE 802.1p priority level, IP precedence and/or packet length to assign priority to traffic which does not match a class.

The following table shows you the internal layer-2 and layer-3 QoS mapping on the P-793H v2. On the P-793H v2, traffic assigned to higher priority queues gets

through faster while traffic in lower index queues is dropped if the network is congested.

Table 68 Internal Layer2 and Layer3 QoS Mapping

PRIORITY QUEUE	LAYER 2	LAYER 3		
	IEEE 802.1P USER PRIORITY (ETHERNET PRIORITY)	TOS (IP PRECEDENCE)	DSCP	IP PACKET LENGTH (BYTE)
0	1	0	000000	
1	2			
2	0	0	000000	>1100
3	3	1	001110 001100 001010 001000	250~1100
4	4	2	010110 010100 010010 010000	
5	5	3	011110 011100 011010 011000	<250
6	6	4	100110 100100 100010 100000	
		5	101110 101000	
7	7	6	110000	
		7	111000	

Dynamic DNS Setup

16.1 Overview

Dynamic DNS allows you to update your current dynamic IP address with one or many dynamic DNS services so that anyone can contact you (in NetMeeting, CU-SeeMe, etc.). You can also access your FTP server or Web site on your own computer using a domain name (for instance myhost.dhs.org, where myhost is a name of your choice) that will never change instead of using an IP address that changes each time you reconnect. Your friends or relatives will always be able to call you even if they don't know your IP address.

First of all, you need to have registered a dynamic DNS account with www.dyndns.org. This is for people with a dynamic IP from their ISP or DHCP server that would still like to have a domain name. The Dynamic DNS service provider will give you a password or key.

16.1.1 What You Need To Know About DDNS

DYNDNS Wildcard

Enabling the wildcard feature for your host causes *.yourhost.dyndns.org to be aliased to the same IP address as yourhost.dyndns.org. This feature is useful if you want to be able to use, for example, www.yourhost.dyndns.org and still reach your hostname.

If you have a private WAN IP address, then you cannot use Dynamic DNS.

16.2 The Dynamic DNS Screen

Use this screen to change your P-793H v2's DDNS. Click **Advanced > Dynamic DNS**. The screen appears as shown.

Figure 106 Advanced > Dynamic DNS

The following table describes the fields in this screen.

Table 69 Advanced > Dynamic DNS

LABEL	DESCRIPTION
Dynamic DNS Setup	
Active Dynamic DNS	Select this check box to use dynamic DNS.
Service Provider	This is the name of your Dynamic DNS service provider.
Dynamic DNS Type	Select the type of service that you are registered for from your Dynamic DNS service provider.
Host Name	Type the domain name assigned to your P-793H v2 by your Dynamic DNS provider. You can specify up to two host names in the field separated by a comma (",").
User Name	Type your user name.
Password	Type the password assigned to you.
Enable Wildcard Option	Select the check box to enable DynDNS Wildcard.

Table 69 Advanced > Dynamic DNS (continued)

LABEL	DESCRIPTION
Enable off line option	This option is available when CustomDNS is selected in the DDNS Type field. Check with your Dynamic DNS service provider to have traffic redirected to a URL (that you can specify) while you are off line.
IP Address Update Policy	
Use WAN IP Address	Select this option to update the IP address of the host name(s) to the WAN IP address.
Dynamic DNS server auto detect IP Address	<p>Select this option only when there are one or more NAT routers between the P-793H v2 and the DDNS server. This feature has the DDNS server automatically detect and use the IP address of the NAT router that has a public IP address.</p> <p>Note: The DDNS server may not be able to detect the proper IP address if there is an HTTP proxy server between the P-793H v2 and the DDNS server.</p>
Use specified IP Address	Type the IP address of the host name(s). Use this if you have a static IP address.
Apply	Click this to save your changes.
Cancel	Click this to restore your previously saved settings.

Remote Management

17.1 Overview

Remote management allows you to determine which services/protocols can access which P-793H v2 interface (if any) from which computers.

The following figure shows remote management of the P-793H v2 coming in from the WAN.

Figure 107 Remote Management From the WAN

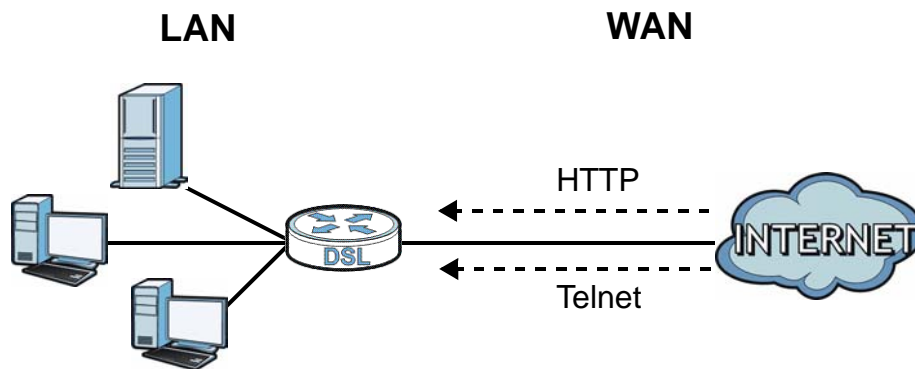

Note: When you configure remote management to allow management from the WAN, you still need to configure a firewall rule to allow access.

You may manage your P-793H v2 from a remote location via:

- Internet (WAN only)
- LAN only
- ALL (WAN and LAN)
- None (Disable)

To disable remote management of a service, select **Disable** in the corresponding **Access Status** field.

You may only have one remote management session running at a time. The P-793H v2 automatically disconnects a remote management session of lower priority when another remote management session of higher priority starts. The priorities for the different types of remote management sessions are as follows.

- 1 Telnet
- 2 HTTP

17.1.1 What You Can Do in the Remote Management Screens

- Use the **WWW** screen ([Section 17.2 on page 241](#)) to configure through which interface(s) and from which IP address(es) users can use HTTP to manage the P-793H v2.
- Use the **Telnet** screen ([Section 17.3 on page 242](#)) to configure through which interface(s) and from which IP address(es) users can use Telnet to manage the P-793H v2.
- Use the **FTP** screen ([Section 17.4 on page 243](#)) to configure through which interface(s) and from which IP address(es) users can use FTP to access the P-793H v2.
- Use the **SNMP** screen ([Section 17.5 on page 248](#)) to configure your P-793H v2's settings for Simple Network Management Protocol management.
- Use the **DNS** screen ([Section 17.6 on page 248](#)) to configure through which interface(s) and from which IP address(es) users can send DNS queries to the P-793H v2.
- Use the **ICMP** screen ([Section 17.7 on page 249](#)) to set whether or not your P-793H v2 will respond to pings and probes for services that you have not made available.

17.1.2 What You Need to Know About Remote Management

Remote Management Limitations

Remote management does not work when:

- You have not enabled that service on the interface in the corresponding remote management screen.
- You have disabled that service in one of the remote management screens.
- The IP address in the **Secured Client IP** field does not match the client IP address. If it does not match, the P-793H v2 will disconnect the session immediately.

- There is already another remote management session with an equal or higher priority running. You may only have one remote management session running at one time.
- There is a firewall rule that blocks it.

Remote Management and NAT

When NAT is enabled:

- Use the P-793H v2's WAN IP address when configuring from the WAN.
- Use the P-793H v2's LAN IP address when configuring from the LAN.

System Timeout

There is a default system management idle timeout of five minutes (three hundred seconds). The P-793H v2 automatically logs you out if the management session remains idle for longer than this timeout period. The management session does not time out when a statistics screen is polling.

17.2 The WWW Screen

Use this screen to specify how to connect to the P-793H v2 from a web browser, such as Internet Explorer. You can also specify which IP addresses the access can come from.

Note: If you disable the **WWW** service in this screen, then the P-793H v2 blocks all HTTP connection attempts.

17.2.1 Configuring the WWW Screen

Click **Advanced > Remote MGMT** to display the **WWW** screen.

Figure 108 Advanced > Remote Management > WWW

The screenshot shows the 'WWW' configuration screen. At the top, there are tabs for 'WWW', 'Telnet', 'FTP', 'SNMP', 'DNS', and 'ICMP'. The 'WWW' tab is selected. Below the tabs, the 'WWW' section is visible. The 'Port' is set to 80. The 'Access Status' is set to 'ALL'. The 'Secured Client IP' is set to 'All' with a radio button selected, and a text box next to it contains '0.0.0.0'. Below these settings, there is a 'Note' section with two points: '1: For UPnP to function normally, the HTTP service must be available for LAN computers using UPnP.' and '2: You may also need to create a Firewall rule'. At the bottom of the screen, there are 'Apply' and 'Cancel' buttons.

The following table describes the labels in this screen.

Table 70 Advanced > Remote Management > WWW

LABEL	DESCRIPTION
Port	You may change the server port number for a service, if needed. However, you must use the same port number in order to use that service for remote management.
Access Status	Select the interface(s) through which a computer may access the P-793H v2 using this service.
Secured Client IP	A secured client is a “trusted” computer that is allowed to communicate with the P-793H v2 using this service. Select All to allow any computer to access the P-793H v2 using this service. Choose Selected to just allow the computer with the IP address that you specify to access the P-793H v2 using this service.
Apply	Click this to save your changes.
Cancel	Click this to restore your previously saved settings.

17.3 The Telnet Screen

You can use Telnet to access the P-793H v2’s command line interface. Specify which interfaces allow Telnet access and from which IP address the access can come.

Click **Advanced > Remote MGMT > Telnet** tab to display the screen as shown.

Figure 109 Advanced > Remote Management > Telnet

The screenshot shows the 'Telnet' configuration screen. At the top, there are tabs for 'WWW', 'Telnet', 'FTP', 'SNMP', 'DNS', and 'ICMP'. The 'Telnet' tab is selected. Below the tabs, the 'Telnet' section contains the following fields:

- Port:** A text input field containing the number '23'.
- Access Status:** A dropdown menu with 'ALL' selected.
- Secured Client IP:** Radio buttons for 'All' (selected) and 'Selected', followed by a text input field containing '0.0.0.0'.

Below these fields is a **Note** icon and text: "Note : You may also need to create a [Firewall](#) rule". At the bottom of the screen are two buttons: 'Apply' and 'Cancel'.

The following table describes the labels in this screen.

Table 71 Advanced > Remote Management > Telnet

LABEL	DESCRIPTION
Port	You may change the server port number for a service if needed, however you must use the same port number in order to use that service for remote management.
Access Status	Select the interface(s) through which a computer may access the P-793H v2 using this service.
Secured Client IP	A secured client is a “trusted” computer that is allowed to communicate with the P-793H v2 using this service. Select All to allow any computer to access the P-793H v2 using this service. Choose Selected to just allow the computer with the IP address that you specify to access the P-793H v2 using this service.
Apply	Click this to save your changes.
Cancel	Click this to restore your previously saved settings.

17.4 The FTP Screen

You can use FTP (File Transfer Protocol) to upload and download the P-793H v2's firmware and configuration files. Please see the User's Guide chapter on firmware and configuration file maintenance for details. To use this feature, your computer must have an FTP client.

Use this screen to specify which interfaces allow FTP access and from which IP address the access can come. To change your P-793H v2's FTP settings, click **Advanced > Remote MGMT > FTP**. The screen appears as shown.

Figure 110 Advanced > Remote Management > FTP

The screenshot shows the FTP configuration interface. At the top, there are navigation tabs: WWW, Telnet, FTP (highlighted in blue), SNMP, DNS, and ICMP. Below the tabs, the title 'FTP' is displayed. The configuration fields are: 'Port' with a text box containing '21'; 'Access Status' with a dropdown menu set to 'ALL'; and 'Secured Client IP' with radio buttons for 'All' (selected) and 'Selected' (with a text box containing '0.0.0.0'). A yellow note icon is followed by the text: 'Note: You may also need to create a [Firewall rule](#)'. At the bottom, there are 'Apply' and 'Cancel' buttons.

The following table describes the labels in this screen.

Table 72 Advanced > Remote Management > FTP

LABEL	DESCRIPTION
Port	You may change the server port number for a service, if needed. However, you must use the same port number in order to use that service for remote management.
Access Status	Select the interface(s) through which a computer may access the P-793H v2 using this service.
Secured Client IP	A secured client is a "trusted" computer that is allowed to communicate with the P-793H v2 using this service. Select All to allow any computer to access the P-793H v2 using this service. Choose Selected to just allow the computer with the IP address that you specify to access the P-793H v2 using this service.
Apply	Click this to save your changes.
Cancel	Click this to restore your previously saved settings.

17.5 The SNMP Screen

Simple Network Management Protocol (SNMP) is a protocol used for exchanging management information between network devices. SNMP is a member of the TCP/IP protocol suite. Your P-793H v2 supports SNMP agent functionality, which allows a manager station to manage and monitor the P-793H v2 through the network. The P-793H v2 supports SNMP version one (SNMPv1) and version two (SNMPv2). The next figure illustrates an SNMP management operation.

Note: SNMP is only available if TCP/IP is configured.

Figure 111 SNMP Management Model

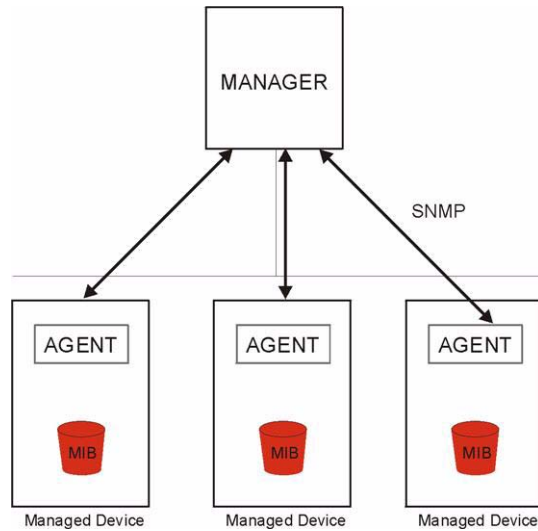

An SNMP managed network consists of two main types of component: agents and a manager.

An agent is a management software module that resides in a managed device (the P-793H v2). An agent translates the local management information from the managed device into a form compatible with SNMP. The manager is the console through which network administrators perform network management functions. It executes applications that control and monitor managed devices.

The managed devices contain object variables/managed objects that define each piece of information to be collected about a device. Examples of variables include such as number of packets received, node port status etc. A Management Information Base (MIB) is a collection of managed objects. SNMP allows a manager and agents to communicate for the purpose of accessing these objects.

SNMP itself is a simple request/response protocol based on the manager/agent model. The manager issues a request and the agent returns responses using the following protocol operations:

- Get - Allows the manager to retrieve an object variable from the agent.
- GetNext - Allows the manager to retrieve the next object variable from a table or list within an agent. In SNMPv1, when a manager wants to retrieve all elements of a table from an agent, it initiates a Get operation, followed by a series of GetNext operations.
- Set - Allows the manager to set values for object variables within an agent.
- Trap - Used by the agent to inform the manager of some events.

17.5.1 Supported MIBs

The P-793H v2 supports MIB II, which is defined in RFC-1213 and RFC-1215. The focus of the MIBs is to let administrators collect statistical data and monitor status and performance.

17.5.2 SNMP Traps

The P-793H v2 will send traps to the SNMP manager when any one of the following events occurs:

Table 73 SNMP Traps

TRAP #	TRAP NAME	DESCRIPTION
0	coldStart (defined in <i>RFC-1215</i>)	A trap is sent after booting (power on).
1	warmStart (defined in <i>RFC-1215</i>)	A trap is sent after booting (software reboot).
4	authenticationFailure (defined in <i>RFC-1215</i>)	A trap is sent to the manager when receiving any SNMP get or set requirements with the wrong community (password).
6	whyReboot (defined in ZYXEL-MIB)	A trap is sent with the reason of restart before rebooting when the system is going to restart (warm start).
6a	For intentional reboot:	A trap is sent with the message "System reboot by user!" if reboot is done intentionally, (for example, download new files, C1 command "sys reboot", etc.).
6b	For fatal error:	A trap is sent with the message of the fatal code if the system reboots because of fatal errors.

17.5.3 Configuring SNMP

To change your P-793H v2's SNMP settings, click **Advanced > Remote MGMT > SNMP**. The screen appears as shown.

Figure 112 Advanced > Remote Management > SNMP

The following table describes the labels in this screen.

Table 74 Advanced > Remote Management > SNMP

LABEL	DESCRIPTION
SNMP	
Port	You may change the server port number for a service, if needed. However, you must use the same port number in order to use that service for remote management.
Access Status	Select the interface(s) through which a computer may access the P-793H v2 using this service.
Secured Client IP	A secured client is a “trusted” computer that is allowed to communicate with the P-793H v2 using this service. Select All to allow any computer to access the P-793H v2 using this service. Choose Selected to just allow the computer with the IP address that you specify to access the P-793H v2 using this service.
SNMP Configuration	
Get Community	Enter the Get Community , which is the password for the incoming Get and GetNext requests from the management station. The default is public and allows all requests.
Set Community	Enter the Set community , which is the password for incoming Set requests from the management station. The default is public and allows all requests.
TrapCommunity	Type the trap community, which is the password sent with each trap to the SNMP manager. The default is public and allows all requests.
TrapDestination	Type the IP address of the station to send your SNMP traps to.

Table 74 Advanced > Remote Management > SNMP

LABEL	DESCRIPTION
Apply	Click this to save your changes.
Cancel	Click this to restore your previously saved settings.

17.6 The DNS Screen

Use DNS (Domain Name System) to map a domain name to its corresponding IP address and vice versa. Refer to [Chapter 7 on page 101](#) for background information.

Use this screen to set from which IP address the P-793H v2 will accept DNS queries and on which interface it can send them your P-793H v2's DNS settings. This feature is not available when the P-793H v2 is set to bridge mode. Click **Advanced > Remote MGMT > DNS** to change your P-793H v2's DNS settings.

Figure 113 Advanced > Remote Management > DNS

The screenshot shows the DNS configuration interface. At the top, there are tabs for WWW, Telnet, FTP, SNMP, DNS (selected), and ICMP. Below the tabs, the DNS settings are displayed:

- Port:** A text input field containing the value "53".
- Access Status:** A dropdown menu currently set to "ALL".
- Secured Client IP:** Radio buttons for "All" (selected) and "Selected", followed by a text input field containing "0.0.0.0".

A note with a yellow icon reads: "Note: You may also need to create a [Firewall](#) rule". At the bottom of the screen, there are "Apply" and "Cancel" buttons.

The following table describes the labels in this screen.

Table 75 Advanced > Remote Management > DNS

LABEL	DESCRIPTION
Port	The DNS service port number is 53 and cannot be changed here.
Access Status	Select the interface(s) through which a computer may send DNS queries to the P-793H v2.
Secured Client IP	A secured client is a "trusted" computer that is allowed to send DNS queries to the P-793H v2. Select All to allow any computer to send DNS queries to the P-793H v2. Choose Selected to just allow the computer with the IP address that you specify to send DNS queries to the P-793H v2.
Apply	Click this to save your changes.
Cancel	Click this to restore your previously saved settings.

17.7 The ICMP Screen

To change your P-793H v2's security settings, click **Advanced > Remote MGMT > ICMP**. The screen appears as shown.

If an outside user attempts to probe an unsupported port on your P-793H v2, an ICMP response packet is automatically returned. This allows the outside user to know the P-793H v2 exists. Your P-793H v2 supports anti-probing, which prevents the ICMP response packet from being sent. This keeps outsiders from discovering your P-793H v2 when unsupported ports are probed.

Note: If you want your device to respond to pings and requests for unauthorized services, you may also need to configure the firewall anti probing settings to match.

Figure 114 Advanced > Remote Management > ICMP

The following table describes the labels in this screen.

Table 76 Advanced > Remote Management > ICMP

LABEL	DESCRIPTION
ICMP	Internet Control Message Protocol is a message control and error-reporting protocol between a host server and a gateway to the Internet. ICMP uses Internet Protocol (IP) datagrams, but the messages are processed by the TCP/IP software and directly apparent to the application user.
Respond to Ping on	The P-793H v2 will not respond to any incoming Ping requests when Disable is selected. Select LAN to reply to incoming LAN Ping requests. Select WAN to reply to incoming WAN Ping requests. Otherwise select LAN & WAN to reply to both incoming LAN and WAN Ping requests.
Do not respond to requests for unauthorized services	Select this option to prevent hackers from finding the P-793H v2 by probing for unused ports. If you select this option, the P-793H v2 will not respond to port request(s) for unused ports, thus leaving the unused ports and the P-793H v2 unseen. If this option is not selected, the P-793H v2 will reply with an ICMP port unreachable packet for a port probe on its unused UDP ports and a TCP reset packet for a port probe on its unused TCP ports. Note that the probing packets must first traverse the P-793H v2's firewall rule checks before reaching this anti-probing mechanism. Therefore if a firewall rule stops a probing packet, the P-793H v2 reacts based on the firewall rule to either send a TCP reset packet for a blocked TCP packet (or an ICMP port-unreachable packet for a blocked UDP packets) or just drop the packets without sending a response packet.

Table 76 Advanced > Remote Management > ICMP

LABEL	DESCRIPTION
Apply	Click this to save your changes.
Cancel	Click this to restore your previously saved settings.

Universal Plug-and-Play (UPnP)

18.1 Overview

Universal Plug and Play (UPnP) is a distributed, open networking standard that uses TCP/IP for simple peer-to-peer network connectivity between devices. A UPnP device can dynamically join a network, obtain an IP address, convey its capabilities and learn about other devices on the network. In turn, a device can leave a network smoothly and automatically when it is no longer in use.

18.1.1 What You Can Do in the UPnP Screen

Use the **UPnP** screen ([Section 18.2 on page 253](#)) to enable UPnP on the P-793H v2 and allow UPnP-enabled applications to automatically configure the P-793H v2.

18.1.2 What You Need to Know About UPnP

Identifying UPnP Devices

UPnP hardware is identified as an icon in the Network Connections folder (Windows XP). Each UPnP compatible device installed on your network will appear as a separate icon. Selecting the icon of a UPnP device will allow you to access the information and properties of that device.

NAT Traversal

UPnP NAT traversal automates the process of allowing an application to operate through NAT. UPnP network devices can automatically configure network addressing, announce their presence in the network to other UPnP devices and enable exchange of simple product and service descriptions. NAT traversal allows the following:

- Dynamic port mapping
- Learning public IP addresses
- Assigning lease times to mappings

Windows Messenger is an example of an application that supports NAT traversal and UPnP.

See the NAT chapter for more information on NAT.

Cautions with UPnP

The automated nature of NAT traversal applications in establishing their own services and opening firewall ports may present network security issues. Network information and configuration may also be obtained and modified by users in some network environments.

When a UPnP device joins a network, it announces its presence with a multicast message. For security reasons, the P-793H v2 allows multicast messages on the LAN only.

All UPnP-enabled devices may communicate freely with each other without additional configuration. Disable UPnP if this is not your intention.

UPnP and ZyXEL

ZyXEL has achieved UPnP certification from the Universal Plug and Play Forum UPnP™ Implementers Corp. (UIC). ZyXEL's UPnP implementation supports Internet Gateway Device (IGD) 1.0.

See the following sections for examples of installing and using UPnP.

18.2 The UPnP Screen

Use the following screen to configure the UPnP settings on your P-793H v2. Click **Advanced > UPnP** to display the screen shown next.

See [Section 18.1 on page 251](#) for more information.

Figure 115 Advanced > UPnP > General

The following table describes the fields in this screen.

Table 77 Advanced > UPnP > General

LABEL	DESCRIPTION
Active the Universal Plug and Play (UPnP) Feature	Select this check box to activate UPnP. Be aware that anyone could use a UPnP application to open the web configurator's login screen without entering the P-793H v2's IP address (although you must still enter the password to access the web configurator).
Allow users to make configuration changes through UPnP	Select this check box to allow UPnP-enabled applications to automatically configure the P-793H v2 so that they can communicate through the P-793H v2, for example by using NAT traversal, UPnP applications automatically reserve a NAT forwarding port in order to communicate with another UPnP enabled device; this eliminates the need to manually configure port forwarding for the UPnP enabled application.
Apply	Click this to save your changes.
Cancel	Click this to restore your previously saved settings.

18.3 Installing UPnP in Windows Example

This section shows how to install UPnP in Windows Me and Windows XP.

Installing UPnP in Windows Me

Follow the steps below to install the UPnP in Windows Me.

- 1 Click **Start** and **Control Panel**. Double-click **Add/Remove Programs**.
- 2 Click on the **Windows Setup** tab and select **Communication** in the **Components** selection box. Click **Details**.

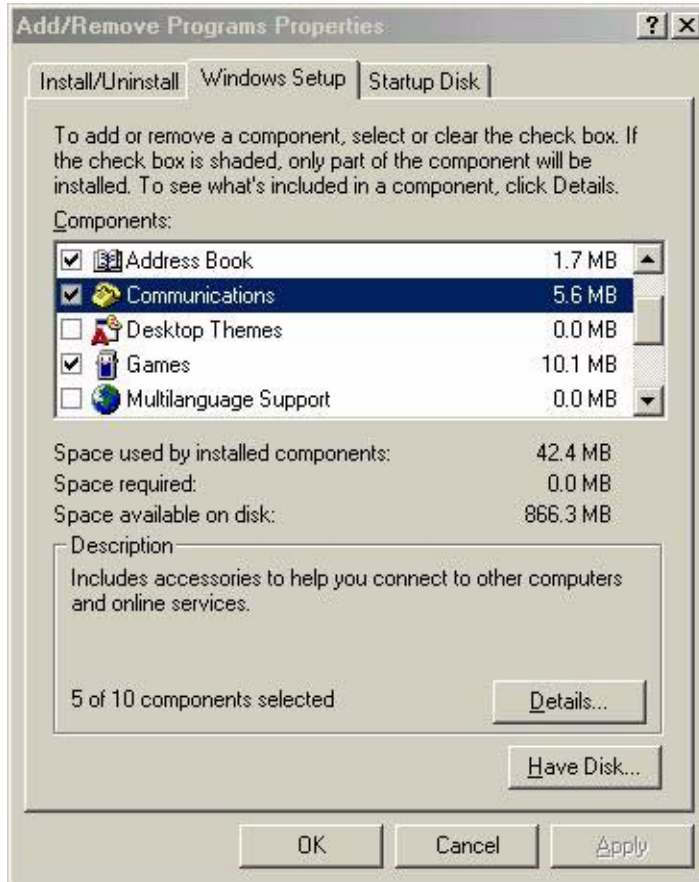

- 3 In the **Communications** window, select the **Universal Plug and Play** check box in the **Components** selection box.

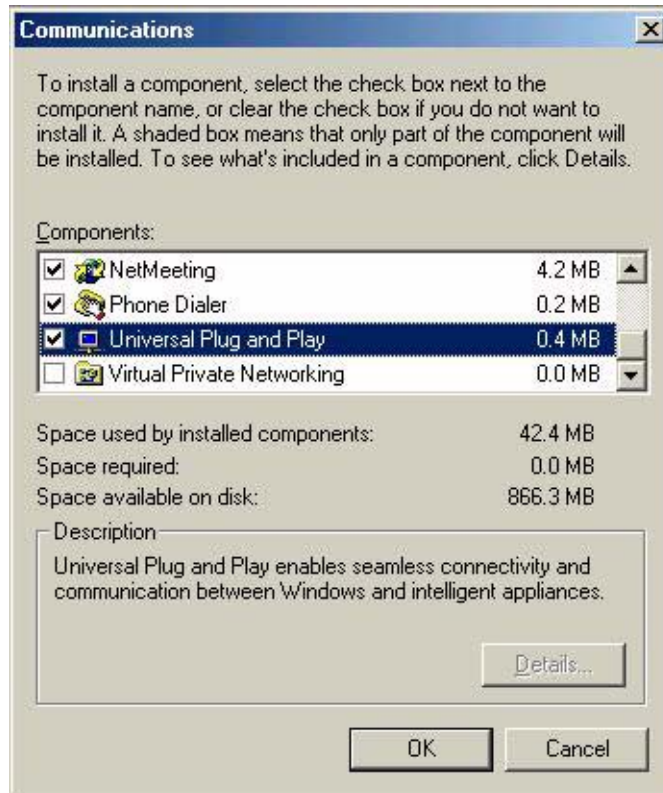

- 4 Click **OK** to go back to the **Add/Remove Programs Properties** window and click **Next**.
- 5 Restart the computer when prompted.

Installing UPnP in Windows XP

Follow the steps below to install the UPnP in Windows XP.

- 1 Click **Start** and **Control Panel**.
- 2 Double-click **Network Connections**.

- 3 In the **Network Connections** window, click **Advanced** in the main menu and select **Optional Networking Components**



- 4 The **Windows Optional Networking Components Wizard** window displays. Select **Networking Service** in the **Components** selection box and click **Details**.

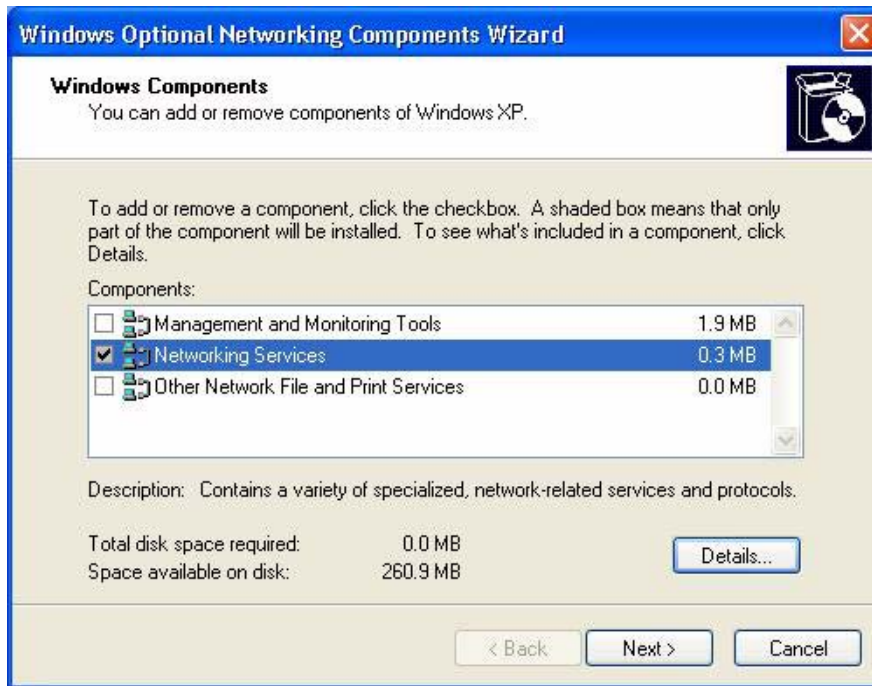

- 5 In the **Networking Services** window, select the **Universal Plug and Play** check box.

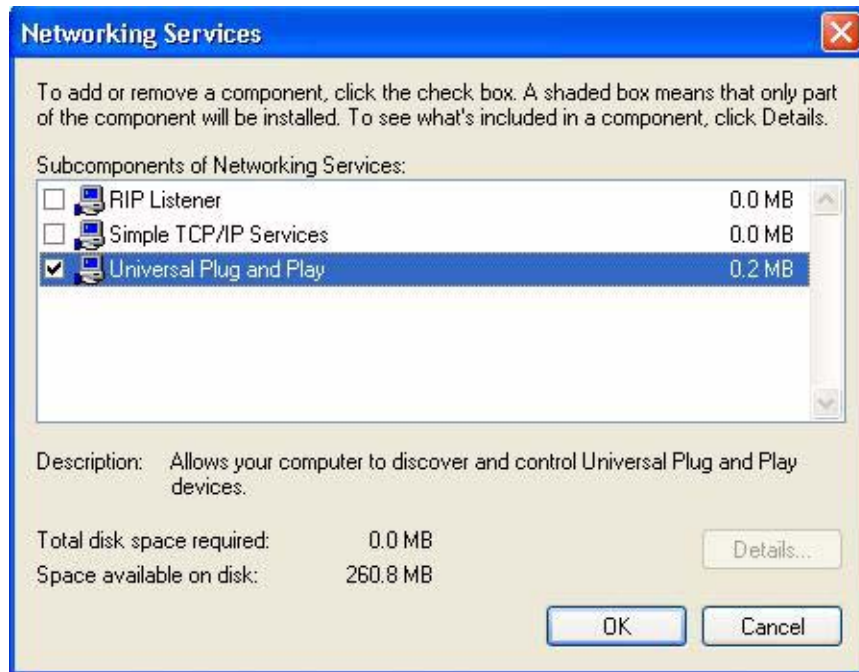

- 6 Click **OK** to go back to the **Windows Optional Networking Component Wizard** window and click **Next**.

18.4 Using UPnP in Windows XP Example

This section shows you how to use the UPnP feature in Windows XP. You must already have UPnP installed in Windows XP and UPnP activated on the P-793H v2.

Make sure the computer is connected to a LAN port of the P-793H v2. Turn on your computer and the P-793H v2.

Auto-discover Your UPnP-enabled Network Device

- 1 Click **Start** and **Control Panel**. Double-click **Network Connections**. An icon displays under Internet Gateway.

- 2 Right-click the icon and select **Properties**.



- 3 In the **Internet Connection Properties** window, click **Settings** to see the port mappings there were automatically created.



- You may edit or delete the port mappings or click **Add** to manually add port mappings.

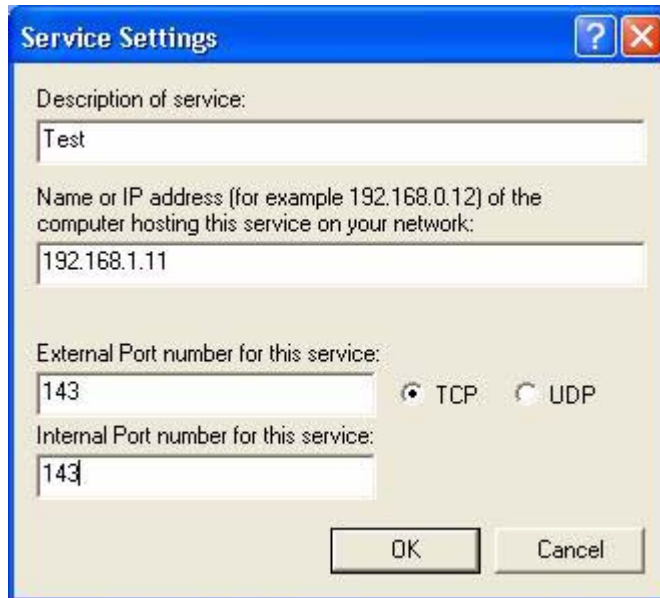
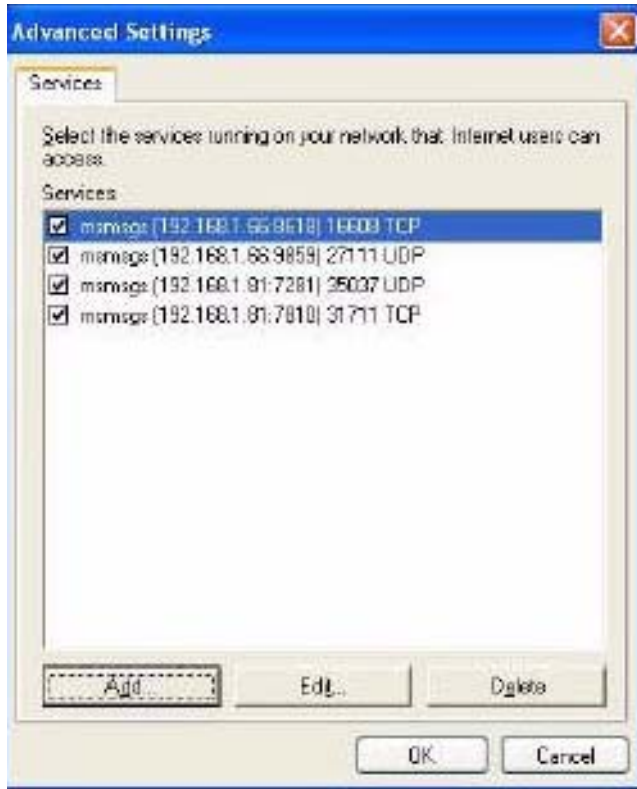

- When the UPnP-enabled device is disconnected from your computer, all port mappings will be deleted automatically.

- 6 Select **Show icon in notification area when connected** option and click **OK**. An icon displays in the system tray.



- 7 Double-click on the icon to display your current Internet connection status.



Web Configurator Easy Access

With UPnP, you can access the web-based configurator on the P-793H v2 without finding out the IP address of the P-793H v2 first. This comes helpful if you do not know the IP address of the P-793H v2.

Follow the steps below to access the web configurator.

- 1 Click **Start** and then **Control Panel**.
- 2 Double-click **Network Connections**.

3 Select **My Network Places** under **Other Places**.

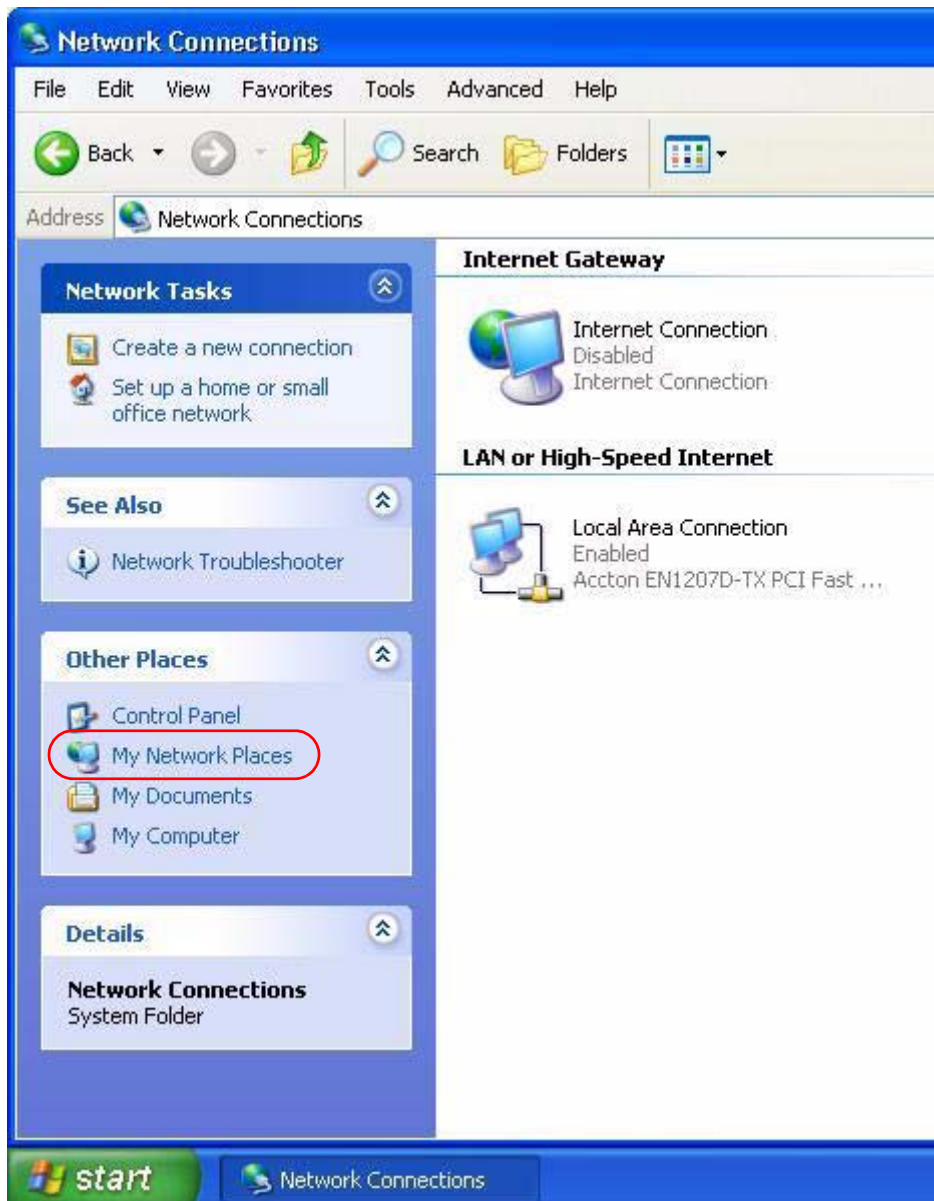

4 An icon with the description for each UPnP-enabled device displays under **Local Network**.

- 5 Right-click on the icon for your P-793H v2 and select **Invoke**. The web configurator login screen displays.

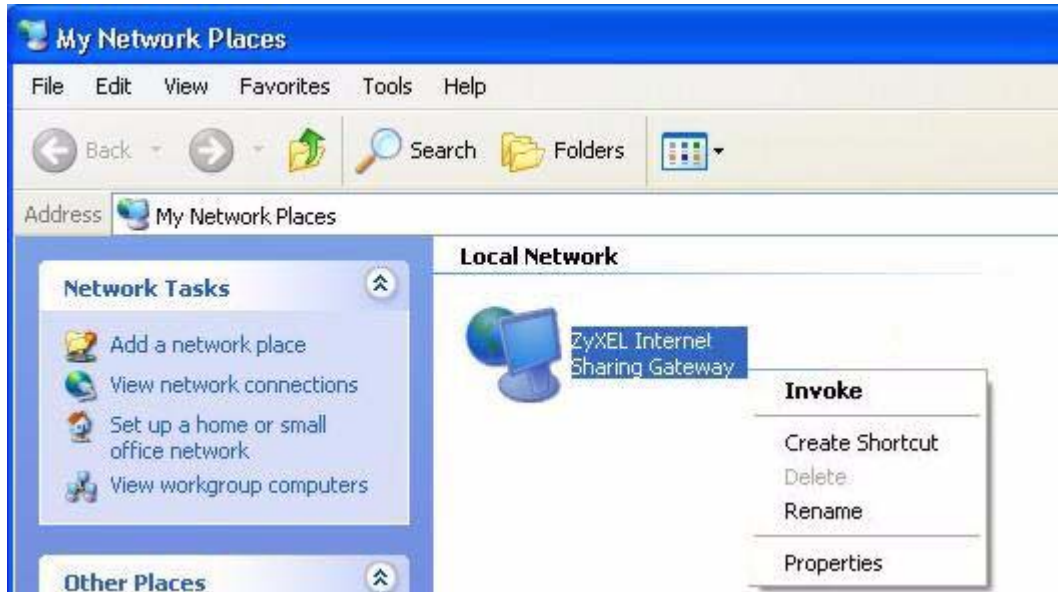

- 6 Right-click on the icon for your P-793H v2 and select **Properties**. A properties window displays with basic information about the P-793H v2.



System Settings

19.1 Overview

This chapter shows you how to configure system related settings, such as system time, password, name, the domain name and the inactivity timeout interval.

19.1.1 What You Can Do in the System Settings Screens

- Use the **General** screen ([Section 19.2 on page 264](#)) to configure system settings.
- Use the **Time Setting** screen ([Section 19.3 on page 266](#)) to set the system time.

19.1.2 What You Need to Know About System Settings

DHCP

DHCP (Dynamic Host Configuration Protocol) is a method of allocating IP addresses to devices on a network from a DHCP Server. Often your ISP or a router on your network performs this function.

LAN

A LAN (local area network) is typically a network which covers a small area, made up of computers and other devices which share resources such as Internet access, printers etc.

19.2 The General Screen

Use this screen to configure system settings such as the system and domain name, inactivity timeout interval and system password.

The **System Name** is for identification purposes. However, because some ISPs check this name you should enter your computer's "Computer Name". Find the system name of your Windows computer by following one of the steps below.

- In Windows 95/98 click **Start, Settings, Control Panel, Network**. Click the Identification tab, note the entry for the **Computer Name** field and enter it as the **System Name**.
- In Windows 2000, click **Start, Settings, Control Panel** and then double-click **System**. Click the **Network Identification** tab and then the **Properties** button. Note the entry for the **Computer name** field and enter it as the **System Name**.
- In Windows XP, click **start, My Computer, View system information** and then click the **Computer Name** tab. Note the entry in the **Full computer name** field and enter it as the P-793H v2 **System Name**.

Click **Maintenance > System** to open the **General** screen.

Figure 116 Maintenance > System > General

The screenshot shows the 'General' tab of the 'System Setup' dialog box. It is divided into two main sections: 'System Setup' and 'Password'.
 In the 'System Setup' section, there are three input fields: 'System Name', 'Domain Name', and 'Administrator Inactivity Timer' (which is currently set to 5 minutes).
 In the 'Password' section, there are two sets of password fields. The first set is for 'User Password', with 'New Password' and 'Retype to confirm' fields. The second set is for 'Admin Password', with 'Old Password', 'New Password', and 'Retype to confirm' fields.
 At the bottom of the dialog, there is a red warning icon and a 'Caution' message: 'Please record your new password whenever you change it. The system will lock you out if you have forgotten your password.' Below this message are 'Apply' and 'Cancel' buttons.

The following table describes the labels in this screen.

Table 78 Maintenance > System > General

LABEL	DESCRIPTION
System Setup	
System Name	Choose a descriptive name for identification purposes. It is recommended you enter your computer's "Computer name" in this field. This name can be up to 30 alphanumeric characters long. Spaces are not allowed, but dashes "-" and underscores "_" are accepted.
Domain Name	Enter the domain name (if you know it) here. If you leave this field blank, the ISP may assign a domain name via DHCP. The domain name entered by you is given priority over the ISP assigned domain name. The Domain Name entry is propagated to the DHCP clients on the LAN.
Administrator Inactivity Timer	Type how many minutes a management session (either via the web configurator or telnet) can be left idle before the session times out. The default is 5 minutes. After it times out you have to log in with your password again. Very long idle timeouts may have security risks. A value of "0" means a management session never times out, no matter how long it has been left idle (not recommended).
Password	
User Password	
New Password	Type your new user password (up to 30 characters). Note that as you type a password, the screen displays a (*) for each character you type. After you change the password, use the new password to access the P-793H v2.
Retype to confirm	Type the new password again for confirmation.
Admin Password	
Old Password	Type the default password or the existing password you use to access the system in this field.
New Password	Type your new system password (up to 30 characters). Note that as you type a password, the screen displays a (*) for each character you type. After you change the password, use the new password to access the P-793H v2.
Retype to confirm	Type the new password again for confirmation.
Apply	Click this to save your changes.
Cancel	Click this to restore your previously saved settings.

19.3 The Time Setting Screen

Use this screen to configure the P-793H v2's time based on your local time zone. To change your P-793H v2's time and date, click **Maintenance > System > Time Setting**. The screen appears as shown.

Figure 117 Maintenance > System > Time Setting

The following table describes the fields in this screen.

Table 79 Maintenance > System > Time Setting

LABEL	DESCRIPTION
Current Time	
Current Time	This field displays the time of your P-793H v2. Each time you reload this page, the P-793H v2 synchronizes the time with the time server.
Current Date	This field displays the date of your P-793H v2. Each time you reload this page, the P-793H v2 synchronizes the date with the time server.
Time and Date Setup	
Manual	Select this radio button to enter the time and date manually. If you configure a new time and date, Time Zone and Daylight Saving at the same time, the new time and date you entered has priority and the Time Zone and Daylight Saving settings do not affect it.

Table 79 Maintenance > System > Time Setting (continued)

LABEL	DESCRIPTION
New Time (hh:mm:ss)	<p>This field displays the last updated time from the time server or the last time configured manually.</p> <p>When you set Time and Date Setup to Manual, enter the new time in this field and then click Apply.</p>
New Date (yyyy/mm/dd)	<p>This field displays the last updated date from the time server or the last date configured manually.</p> <p>When you set Time and Date Setup to Manual, enter the new date in this field and then click Apply.</p>
Get from Time Server	<p>Select this radio button to have the P-793H v2 get the time and date from the time server you specified below.</p>
Time Protocol	<p>Select the time service protocol that your time server sends when you turn on the P-793H v2. Not all time servers support all protocols, so you may have to check with your ISP/network administrator or use trial and error to find a protocol that works.</p> <p>The main difference between them is the format.</p> <p>Daytime (RFC 867) format is day/month/year/time zone of the server.</p> <p>Time (RFC 868) format displays a 4-byte integer giving the total number of seconds since 1970/1/1 at 0:0:0.</p> <p>The default, NTP (RFC 1305), is similar to Time (RFC 868).</p>
Time Server Address	<p>Enter the IP address or URL (up to 20 extended ASCII characters in length) of your time server. Check with your ISP/network administrator if you are unsure of this information.</p>
Time Zone Setup	
Time Zone	<p>Choose the time zone of your location. This will set the time difference between your time zone and Greenwich Mean Time (GMT).</p>
Daylight Savings	<p>Daylight saving is a period from late spring to early fall when many countries set their clocks ahead of normal local time by one hour to give more daytime light in the evening.</p> <p>Select this option if you use Daylight Saving Time.</p>
Start Date	<p>Configure the day and time when Daylight Saving Time starts if you selected Enable Daylight Saving. The o'clock field uses the 24 hour format. Here are a couple of examples:</p> <p>Daylight Saving Time starts in most parts of the United States on the second Sunday of March. Each time zone in the United States starts using Daylight Saving Time at 2 A.M. local time. So in the United States you would select Second, Sunday, March and type 2 in the o'clock field.</p> <p>Daylight Saving Time starts in the European Union on the last Sunday of March. All of the time zones in the European Union start using Daylight Saving Time at the same moment (1 A.M. GMT or UTC). So in the European Union you would select Last, Sunday, March. The time you type in the o'clock field depends on your time zone. In Germany for instance, you would type 2 because Germany's time zone is one hour ahead of GMT or UTC (GMT+1).</p>

Table 79 Maintenance > System > Time Setting (continued)

LABEL	DESCRIPTION
End Date	<p>Configure the day and time when Daylight Saving Time ends if you selected Enable Daylight Saving. The o'clock field uses the 24 hour format. Here are a couple of examples:</p> <p>Daylight Saving Time ends in the United States on the first Sunday of November. Each time zone in the United States stops using Daylight Saving Time at 2 A.M. local time. So in the United States you would select First, Sunday, November and type 2 in the o'clock field.</p> <p>Daylight Saving Time ends in the European Union on the last Sunday of October. All of the time zones in the European Union stop using Daylight Saving Time at the same moment (1 A.M. GMT or UTC). So in the European Union you would select Last, Sunday, October. The time you type in the o'clock field depends on your time zone. In Germany for instance, you would type 2 because Germany's time zone is one hour ahead of GMT or UTC (GMT+1).</p>
Apply	Click this to save your changes.
Cancel	Click this to restore your previously saved settings.

20.1 Overview

This chapter contains information about configuring general log settings and viewing the P-793H v2's logs.

The web configurator allows you to choose which categories of events and/or alerts to have the P-793H v2 log and then display the logs or have the P-793H v2 send them to an administrator (as e-mail) or to a syslog server.

20.1.1 What You Can Do in the Log Screens

- Use the **View Log** screen ([Section 20.2 on page 270](#)) to see the logs for the categories that you selected in the **Log Settings** screen.
- Use The **Log Settings** screen ([Section 20.3 on page 271](#)) to configure the mail server, the syslog server, when to send logs and what logs to send.

20.1.2 What You Need To Know About Logs

Alerts

An alert is a message that is enabled as soon as the event occurs. They include system errors, attacks (access control) and attempted access to blocked web sites. Some categories such as **System Errors** consist of both logs and alerts. You may differentiate them by their color in the **View Log** screen. Alerts display in red and logs display in black.

Logs

A log is a message about an event that occurred on your P-793H v2. For example, when someone logs in to the P-793H v2, you can set a schedule for how often logs should be enabled, or sent to a syslog server.

20.2 The View Log Screen

Use the **View Log** screen to see the logs for the categories that you selected in the **Log Settings** screen (see [Section 20.3 on page 271](#)). Click **Maintenance > Logs** to open the **View Log** screen.

Entries in red indicate alerts. The log wraps around and deletes the old entries after it fills. Click a column heading to sort the entries by that column's criteria. Click the heading cell again to reverse the sort order. A triangle indicates ascending or descending sort order.

Figure 118 Maintenance > Logs > View Log

The screenshot shows the 'View Log' screen with a 'View Logs' section. It includes a 'Display:' dropdown menu set to 'All Logs', and buttons for 'Email Log Now', 'Refresh', and 'Clear Log'. Below these is a table with the following data:

#	Time ^	Message	Source	Destination	Notes
1	01/01/2000 00:33:40	WEB Login Successfully			User:admin
2	01/01/2000 00:31:32	none: UDP	192.168.1.1:53	192.168.1.34:1197	ACCESS PERMITTED
3	01/01/2000 00:31:32	none: UDP	192.168.1.1:53	192.168.1.34:1196	ACCESS PERMITTED
4	01/01/2000 00:31:32	none: UDP	192.168.1.1:53	192.168.1.34:1195	ACCESS PERMITTED
5	01/01/2000 00:30:23	WEB Login Successfully			User:user

The following table describes the fields in this screen.

Table 80 Maintenance > Logs > View Log

LABEL	DESCRIPTION
Display	The categories that you select in the Log Settings screen display in the drop-down list box. Select a category of logs to view; select All Logs to view logs from all of the log categories that you selected in the Log Settings page.
Email Log Now	Click this to send the log screen to the e-mail address specified in the Log Settings page (make sure that you have first filled in the E-mail Log Settings fields in Log Settings).
Refresh	Click this to renew the log screen.
Clear Log	Click this to delete all the logs.
#	This field is a sequential value and is not associated with a specific entry.
Time	This field displays the time the log was recorded.
Message	This field states the reason for the log.
Source	This field lists the source IP address and the port number of the incoming packet.

Table 80 Maintenance > Logs > View Log

LABEL	DESCRIPTION
Destination	This field lists the destination IP address and the port number of the incoming packet.
Notes	This field displays additional information about the log entry.

20.3 The Log Settings Screen

Use the **Log Settings** screen to configure the mail server, the syslog server, when to send logs and what logs to send.

To change your P-793H v2's log settings, click **Maintenance > Logs > Log Settings**. The screen appears as shown.

Alerts are e-mailed as soon as they happen. Logs may be e-mailed as soon as the log is full. Selecting many alert and/or log categories (especially **Access Control**) may result in many e-mails being sent.

Figure 119 Maintenance > Logs > Log Settings

The screenshot shows the 'Log Settings' configuration page. It is organized into three main sections:

- E-mail Log Settings:**
 - Mail Server: [Text Field] (Outgoing SMTP Server Name or IP Address)
 - Mail Subject: [Text Field]
 - Send Log to: [Text Field] (E-Mail Address)
 - Send Alerts to: [Text Field] (E-Mail Address)
 - Log Schedule: When Log is Full [Dropdown]
 - Day for Sending Log: Monday [Dropdown]
 - Time for Sending Log: 0 (hour) 0 (minute)
 - Clear log after sending mail
- Syslog Logging:**
 - Active
 - Syslog IP Address: 0.0.0.0 (Server Name or IP Address)
 - Log Facility: Local 1 [Dropdown]
- Active Log and Alert:**
 - Log:**
 - System Maintenance
 - System Errors
 - Access Control
 - UPnP
 - Forward Web Sites
 - Blocked Web Sites
 - Attacks
 - IPSec
 - IKE
 - Any IP
 - PKI
 - Send Immediate Alert:**
 - System Errors
 - Access Control
 - Blocked Web Sites
 - Attacks
 - IPSec
 - IKE
 - PKI

At the bottom of the page, there are 'Apply' and 'Cancel' buttons.

The following table describes the fields in this screen.

Table 81 Maintenance > Logs > Log Settings

LABEL	DESCRIPTION
E-mail Log Settings	
Mail Server	Enter the server name or the IP address of the mail server for the e-mail addresses specified below. If this field is left blank, logs and alert messages will not be sent via E-mail.
Mail Subject	Type a title that you want to be in the subject line of the log e-mail message that the P-793H v2 sends. Not all P-793H v2 models have this field.
Send Log to	The P-793H v2 sends logs to the e-mail address specified in this field. If this field is left blank, the P-793H v2 does not send logs via e-mail.
Send Alerts to	Alerts are real-time notifications that are sent as soon as an event, such as a DoS attack, system error, or forbidden web access attempt occurs. Enter the E-mail address where the alert messages will be sent. Alerts include system errors, attacks and attempted access to blocked web sites. If this field is left blank, alert messages will not be sent via E-mail.
Log Schedule	<p>This drop-down menu is used to configure the frequency of log messages being sent as E-mail:</p> <ul style="list-style-type: none"> • Daily • Weekly • Hourly • When Log is Full • None. <p>If you select Weekly or Daily, specify a time of day when the E-mail should be sent. If you select Weekly, then also specify which day of the week the E-mail should be sent. If you select When Log is Full, an alert is sent when the log fills up. If you select None, no log messages are sent.</p>
Day for Sending Log	Use the drop down list box to select which day of the week to send the logs.
Time for Sending Log	Enter the time of the day in 24-hour format (for example 23:00 equals 11:00 pm) to send the logs.
Clear log after sending mail	Select the checkbox to delete all the logs after the P-793H v2 sends an E-mail of the logs.
Syslog Logging	The P-793H v2 sends a log to an external syslog server.
Active	Click Active to enable syslog logging.
Syslog IP Address	Enter the server name or IP address of the syslog server that will log the selected categories of logs.
Log Facility	Select a location from the drop down list box. The log facility allows you to log the messages to different files in the syslog server. Refer to the syslog server manual for more information.
Active Log and Alert	
Log	Select the categories of logs that you want to record.

Table 81 Maintenance > Logs > Log Settings

LABEL	DESCRIPTION
Send Immediate Alert	Select log categories for which you want the P-793H v2 to send E-mail alerts immediately.
Apply	Click this to save your customized settings and exit this screen.
Cancel	Click this to restore your previously saved settings.

20.4 SMTP Error Messages

If there are difficulties in sending e-mail the following error message appears.

"SMTP action request failed. ret= ??". The "??"are described in the following table.

Table 82 SMTP Error Messages

-1 means P-793H v2 out of socket
-2 means tcp SYN fail
-3 means smtp server OK fail
-4 means HELO fail
-5 means MAIL FROM fail
-6 means RCPT TO fail
-7 means DATA fail
-8 means mail data send fail

20.4.1 Example E-mail Log

An "End of Log" message displays for each mail in which a complete log has been sent. The following is an example of a log sent by e-mail.

- You may edit the subject title.

- "End of Log" message shows that a complete log has been sent.

Figure 120 E-mail Log Example

```

Subject:
      Firewall Alert From
Date:
      Fri, 07 Apr 2000 10:05:42
From:
      user@zyxel.com
To:
      user@zyxel.com
1|Apr  7 00 |From:192.168.1.1      To:192.168.1.255  |default policy |forward
  | 09:54:03 |UDP      src port:00520 dest port:00520  |<1,00>         |
2|Apr  7 00 |From:192.168.1.131   To:192.168.1.255  |default policy |forward
  | 09:54:17 |UDP      src port:00520 dest port:00520  |<1,00>         |
3|Apr  7 00 |From:192.168.1.6     To:10.10.10.10    |match           |forward
  | 09:54:19 |UDP      src port:03516 dest port:00053  |<1,01>         |
.....{snip}.....
.....{snip}.....
126|Apr  7 00 |From:192.168.1.1     To:192.168.1.255  |match           |forward
   | 10:05:00 |UDP      src port:00520 dest port:00520  |<1,02>         |
127|Apr  7 00 |From:192.168.1.131   To:192.168.1.255  |match           |forward
   | 10:05:17 |UDP      src port:00520 dest port:00520  |<1,02>         |
128|Apr  7 00 |From:192.168.1.1     To:192.168.1.255  |match           |forward
   | 10:05:30 |UDP      src port:00520 dest port:00520  |<1,02>         |
End of Firewall Log

```

20.5 Log Descriptions

This section provides descriptions of example log messages.

Table 83 System Maintenance Logs

LOG MESSAGE	DESCRIPTION
Time calibration is successful	The router has adjusted its time based on information from the time server.
Time calibration failed	The router failed to get information from the time server.
WAN interface gets IP: %s	A WAN interface got a new IP address from the DHCP, PPPoE, or dial-up server.
DHCP client IP expired	A DHCP client's IP address has expired.
DHCP server assigns %s	The DHCP server assigned an IP address to a client.
Successful WEB login	Someone has logged on to the router's web configurator interface.
WEB login failed	Someone has failed to log on to the router's web configurator interface.
Successful TELNET login	Someone has logged on to the router via telnet.
TELNET login failed	Someone has failed to log on to the router via telnet.
Successful FTP login	Someone has logged on to the router via ftp.

Table 83 System Maintenance Logs (continued)

LOG MESSAGE	DESCRIPTION
FTP login failed	Someone has failed to log on to the router via ftp.
NAT Session Table is Full!	The maximum number of NAT session table entries has been exceeded and the table is full.
Starting Connectivity Monitor	Starting Connectivity Monitor.
Time initialized by Daytime Server	The router got the time and date from the Daytime server.
Time initialized by Time server	The router got the time and date from the time server.
Time initialized by NTP server	The router got the time and date from the NTP server.
Connect to Daytime server fail	The router was not able to connect to the Daytime server.
Connect to Time server fail	The router was not able to connect to the Time server.
Connect to NTP server fail	The router was not able to connect to the NTP server.
Too large ICMP packet has been dropped	The router dropped an ICMP packet that was too large.
Configuration Change: PC = 0x%x, Task ID = 0x%x	The router is saving configuration changes.
Successful SSH login	Someone has logged on to the router's SSH server.
SSH login failed	Someone has failed to log on to the router's SSH server.
Successful HTTPS login	Someone has logged on to the router's web configurator interface using HTTPS protocol.
HTTPS login failed	Someone has failed to log on to the router's web configurator interface using HTTPS protocol.

Table 84 System Error Logs

LOG MESSAGE	DESCRIPTION
%s exceeds the max. number of session per host!	This attempt to create a NAT session exceeds the maximum number of NAT session table entries allowed to be created per host.
setNetBIOSFilter: calloc error	The router failed to allocate memory for the NetBIOS filter settings.
readNetBIOSFilter: calloc error	The router failed to allocate memory for the NetBIOS filter settings.
WAN connection is down.	A WAN connection is down. You cannot access the network through this interface.

Table 85 Access Control Logs

LOG MESSAGE	DESCRIPTION
Firewall default policy: [TCP UDP IGMP ESP GRE OSPF] <Packet Direction>	Attempted TCP/UDP/IGMP/ESP/GRE/OSPF access matched the default policy and was blocked or forwarded according to the default policy's setting.
Firewall rule [NOT] match:[TCP UDP IGMP ESP GRE OSPF] <Packet Direction>, <rule:%d>	Attempted TCP/UDP/IGMP/ESP/GRE/OSPF access matched (or did not match) a configured firewall rule (denoted by its number) and was blocked or forwarded according to the rule.
Triangle route packet forwarded: [TCP UDP IGMP ESP GRE OSPF]	The firewall allowed a triangle route session to pass through.
Packet without a NAT table entry blocked: [TCP UDP IGMP ESP GRE OSPF]	The router blocked a packet that didn't have a corresponding NAT table entry.
Router sent blocked web site message: TCP	The router sent a message to notify a user that the router blocked access to a web site that the user requested.

Table 86 TCP Reset Logs

LOG MESSAGE	DESCRIPTION
Under SYN flood attack, sent TCP RST	The router sent a TCP reset packet when a host was under a SYN flood attack (the TCP incomplete count is per destination host.)
Exceed TCP MAX incomplete, sent TCP RST	The router sent a TCP reset packet when the number of TCP incomplete connections exceeded the user configured threshold. (the TCP incomplete count is per destination host.) Note: Refer to TCP Maximum Incomplete in the Firewall Attack Alerts screen.
Peer TCP state out of order, sent TCP RST	The router sent a TCP reset packet when a TCP connection state was out of order. Note: The firewall refers to RFC793 Figure 6 to check the TCP state.
Firewall session time out, sent TCP RST	The router sent a TCP reset packet when a dynamic firewall session timed out. Default timeout values: ICMP idle timeout (s): 60 UDP idle timeout (s): 60 TCP connection (three way handshaking) timeout (s): 30 TCP FIN-wait timeout (s): 60 TCP idle (established) timeout (s): 3600

Table 86 TCP Reset Logs (continued)

LOG MESSAGE	DESCRIPTION
Exceed MAX incomplete, sent TCP RST	The router sent a TCP reset packet when the number of incomplete connections (TCP and UDP) exceeded the user-configured threshold. (Incomplete count is for all TCP and UDP connections through the firewall.)Note: When the number of incomplete connections (TCP + UDP) > "Maximum Incomplete High", the router sends TCP RST packets for TCP connections and destroys TOS (firewall dynamic sessions) until incomplete connections < "Maximum Incomplete Low".
Access block, sent TCP RST	The router sends a TCP RST packet and generates this log if you turn on the firewall TCP reset mechanism (via CLI command: "sys firewall tcrst").

Table 87 Packet Filter Logs

LOG MESSAGE	DESCRIPTION
[TCP UDP ICMP IGMP Generic] packet filter matched (set: %d, rule: %d)	Attempted access matched a configured filter rule (denoted by its set and rule number) and was blocked or forwarded according to the rule.

For type and code details, see [Table 96 on page 280](#).

Table 88 ICMP Logs

LOG MESSAGE	DESCRIPTION
Firewall default policy: ICMP <Packet Direction>, <type:%d>, <code:%d>	ICMP access matched the default policy and was blocked or forwarded according to the user's setting.
Firewall rule [NOT] match: ICMP <Packet Direction>, <rule:%d>, <type:%d>, <code:%d>	ICMP access matched (or didn't match) a firewall rule (denoted by its number) and was blocked or forwarded according to the rule.
Triangle route packet forwarded: ICMP	The firewall allowed a triangle route session to pass through.
Packet without a NAT table entry blocked: ICMP	The router blocked a packet that didn't have a corresponding NAT table entry.
Unsupported/out-of-order ICMP: ICMP	The firewall does not support this kind of ICMP packets or the ICMP packets are out of order.
Router reply ICMP packet: ICMP	The router sent an ICMP reply packet to the sender.

Table 89 CDR Logs

LOG MESSAGE	DESCRIPTION
board %d line %d channel %d, call %d, %s C01 Outgoing Call dev=%x ch=%x %s	The router received the setup requirements for a call. "call" is the reference (count) number of the call. "dev" is the device type (3 is for dial-up, 6 is for PPPoE, 10 is for PPTP). "channel" or "ch" is the call channel ID. For example, "board 0 line 0 channel 0, call 3, C01 Outgoing Call dev=6 ch=0" Means the router has dialed to the PPPoE server 3 times.
board %d line %d channel %d, call %d, %s C02 OutCall Connected %d %s	The PPPoE, PPTP or dial-up call is connected.
board %d line %d channel %d, call %d, %s C02 Call Terminated	The PPPoE, PPTP or dial-up call was disconnected.

Table 90 PPP Logs

LOG MESSAGE	DESCRIPTION
ppp:LCP Starting	The PPP connection's Link Control Protocol stage has started.
ppp:LCP Opening	The PPP connection's Link Control Protocol stage is opening.
ppp:CHAP Opening	The PPP connection's Challenge Handshake Authentication Protocol stage is opening.
ppp:IPCP Starting	The PPP connection's Internet Protocol Control Protocol stage is starting.
ppp:IPCP Opening	The PPP connection's Internet Protocol Control Protocol stage is opening.
ppp:LCP Closing	The PPP connection's Link Control Protocol stage is closing.
ppp:IPCP Closing	The PPP connection's Internet Protocol Control Protocol stage is closing.

Table 91 UPnP Logs

LOG MESSAGE	DESCRIPTION
UPnP pass through Firewall	UPnP packets can pass through the firewall.

Table 92 Content Filtering Logs

LOG MESSAGE	DESCRIPTION
%s: block keyword	The content of a requested web page matched a user defined keyword.
%s	The system forwarded web content.

For type and code details, see [Table 96 on page 280](#).

Table 93 Attack Logs

LOG MESSAGE	DESCRIPTION
attack [TCP UDP IGMP ESP GRE OSPF]	The firewall detected a TCP/UDP/IGMP/ESP/GRE/OSPF attack.
attack ICMP (type:%d, code:%d)	The firewall detected an ICMP attack.
land [TCP UDP IGMP ESP GRE OSPF]	The firewall detected a TCP/UDP/IGMP/ESP/GRE/OSPF land attack.
land ICMP (type:%d, code:%d)	The firewall detected an ICMP land attack.
ip spoofing - WAN [TCP UDP IGMP ESP GRE OSPF]	The firewall detected an IP spoofing attack on the WAN port.
ip spoofing - WAN ICMP (type:%d, code:%d)	The firewall detected an ICMP IP spoofing attack on the WAN port.
icmp echo : ICMP (type:%d, code:%d)	The firewall detected an ICMP echo attack.
syn flood TCP	The firewall detected a TCP syn flood attack.
ports scan TCP	The firewall detected a TCP port scan attack.
teardrop TCP	The firewall detected a TCP teardrop attack.
teardrop UDP	The firewall detected an UDP teardrop attack.
teardrop ICMP (type:%d, code:%d)	The firewall detected an ICMP teardrop attack.
illegal command TCP	The firewall detected a TCP illegal command attack.
NetBIOS TCP	The firewall detected a TCP NetBIOS attack.
ip spoofing - no routing entry [TCP UDP IGMP ESP GRE OSPF]	The firewall classified a packet with no source routing entry as an IP spoofing attack.
ip spoofing - no routing entry ICMP (type:%d, code:%d)	The firewall classified an ICMP packet with no source routing entry as an IP spoofing attack.
vulnerability ICMP (type:%d, code:%d)	The firewall detected an ICMP vulnerability attack.
traceroute ICMP (type:%d, code:%d)	The firewall detected an ICMP traceroute attack.

Table 94 802.1X Logs

LOG MESSAGE	DESCRIPTION
RADIUS accepts user.	A user was authenticated by the RADIUS Server.
RADIUS rejects user. Pls check RADIUS Server.	A user was not authenticated by the RADIUS Server. Please check the RADIUS Server.
User logout because of session timeout expired.	The router logged out a user whose session expired.

Table 94 802.1X Logs (continued)

LOG MESSAGE	DESCRIPTION
User logout because of user deassociation.	The router logged out a user who ended the session.
User logout because of no authentication response from user.	The router logged out a user from which there was no authentication response.
User logout because of idle timeout expired.	The router logged out a user whose idle timeout period expired.
User logout because of user request.	A user logged out.
No response from RADIUS. Pls check RADIUS Server.	There is no response message from the RADIUS server, please check the RADIUS server.
Use RADIUS to authenticate user.	The RADIUS server is operating as the authentication server.
No Server to authenticate user.	There is no authentication server to authenticate a user.

Table 95 ACL Setting Notes

PACKET DIRECTION	DIRECTION	DESCRIPTION
(L to W)	LAN to WAN	ACL set for packets traveling from the LAN to the WAN.
(W to L)	WAN to LAN	ACL set for packets traveling from the WAN to the LAN.
(L to L/P-793H v2)	LAN to LAN/P-793H v2	ACL set for packets traveling from the LAN to the LAN or the P-793H v2.
(W to W/P-793H v2)	WAN to WAN/P-793H v2	ACL set for packets traveling from the WAN to the WAN or the P-793H v2.

Table 96 ICMP Notes

TYPE	CODE	DESCRIPTION
0		Echo Reply
	0	Echo reply message
3		Destination Unreachable
	0	Net unreachable
	1	Host unreachable
	2	Protocol unreachable
	3	Port unreachable
	4	A packet that needed fragmentation was dropped because it was set to Don't Fragment (DF)
	5	Source route failed

Table 96 ICMP Notes (continued)

TYPE	CODE	DESCRIPTION
4		Source Quench
	0	A gateway may discard internet datagrams if it does not have the buffer space needed to queue the datagrams for output to the next network on the route to the destination network.
5		Redirect
	0	Redirect datagrams for the Network
	1	Redirect datagrams for the Host
	2	Redirect datagrams for the Type of Service and Network
	3	Redirect datagrams for the Type of Service and Host
8		Echo
	0	Echo message
11		Time Exceeded
	0	Time to live exceeded in transit
	1	Fragment reassembly time exceeded
12		Parameter Problem
	0	Pointer indicates the error
13		Timestamp
	0	Timestamp request message
14		Timestamp Reply
	0	Timestamp reply message
15		Information Request
	0	Information request message
16		Information Reply
	0	Information reply message

Table 97 Syslog Logs

LOG MESSAGE	DESCRIPTION
<pre><Facility*8 + Severity>Mon dd hr:mm:ss hostname src="<srcIP:srcPort>" dst="<dstIP:dstPort>" msg="<msg>" note="<note>" devID="<mac address last three numbers>" cat="<category>"</pre>	<p>"This message is sent by the system ("RAS" displays as the system name if you haven't configured one) when the router generates a syslog. The facility is defined in the web MAIN MENU->LOGS->Log Settings page. The severity is the log's syslog class. The definition of messages and notes are defined in the various log charts throughout this appendix. The "devID" is the last three characters of the MAC address of the router's LAN port. The "cat" is the same as the category in the router's logs.</p>

The following table shows RFC-2408 ISAKMP payload types that the log displays. Please refer to RFC 2408 for detailed information on each type.

Table 98 RFC-2408 ISAKMP Payload Types

LOG DISPLAY	PAYLOAD TYPE
SA	Security Association
PROP	Proposal
TRANS	Transform
KE	Key Exchange
ID	Identification
CER	Certificate
CER_REQ	Certificate Request
HASH	Hash
SIG	Signature
NONCE	Nonce
NOTFY	Notification
DEL	Delete
VID	Vendor ID

21.1 Overview

This chapter explains how to upload new firmware, manage configuration files and restart your P-793H v2.

Use the instructions in this chapter to change the device's configuration file or upgrade its firmware. After you configure your device, you can backup the configuration file to a computer. That way if you later misconfigure the device, you can upload the backed up configuration file to return to your previous settings. You can alternately upload the factory default configuration file if you want to return the device to the original default settings. The firmware determines the device's available features and functionality. You can download new firmware releases from your nearest ZyXEL FTP site (or www.zyxel.com) to use to upgrade your device's performance.

Only use firmware for your device's specific model. Refer to the label on the bottom of your P-793H v2.

21.1.1 What You Can Do in the Tool Screens

- Use the **Firmware Upgrade** screen ([Section 21.2 on page 291](#)) to upload firmware to your device.
- Use the **Configuration** screen ([Section 21.3 on page 293](#)) to backup and restore device configurations. You can also reset your device settings back to the factory default.
- Use the **Restart** screen ([Section 21.4 on page 295](#)) to restart your ZyXEL device.

21.1.2 What You Need To Know About Tools

Filename Conventions

The configuration file (often called the romfile or rom-0) contains the factory default settings in the menus such as password, DHCP Setup, TCP/IP Setup, etc. It arrives from ZyXEL with a "rom" filename extension. Once you have customized the P-793H v2's settings, they can be saved back to your computer under a filename of your choosing.

ZyNOS (ZyXEL Network Operating System sometimes referred to as the "ras" file) is the system firmware and has a "bin" filename extension. Find this firmware at www.zyxel.com. With many FTP and TFTP clients, the filenames are similar to those seen next.

```
ftp> put firmware.bin ras
```

This is a sample FTP session showing the transfer of the computer file "firmware.bin" to the P-793H v2.

```
ftp> get rom-0 config.cfg
```

This is a sample FTP session saving the current configuration to the computer file "config.cfg".

If your (T)FTP client does not allow you to have a destination filename different than the source, you will need to rename them as the P-793H v2 only recognizes "rom-0" and "ras". Be sure you keep unaltered copies of both files for later use.

The following table is a summary. Please note that the internal filename refers to the filename on the P-793H v2 and the external filename refers to the filename not on the P-793H v2, that is, on your computer, local network or FTP site and so the name (but not the extension) may vary. After uploading new firmware, see the **Status** screen to confirm that you have uploaded the correct firmware version.

Table 99 Filename Conventions

FILE TYPE	INTERNAL NAME	EXTERNAL NAME	DESCRIPTION
Configuration File	Rom-0	This is the configuration filename on the P-793H v2. Uploading the rom-0 file replaces the entire ROM file system, including your P-793H v2 configurations, system-related data (including the default password), the error log and the trace log.	*.rom
Firmware	Ras	This is the generic name for the ZyNOS firmware on the P-793H v2.	*.bin

FTP Restrictions

FTP will not work when:

- 1 The firewall is active (turn the firewall off or create a firewall rule to allow access from the WAN).
- 2 You have disabled the FTP service in the **Remote Management** screen.
- 3 The IP you entered in the Secured Client IP field does not match the client IP. If it does not match, the device will disallow the FTP session.

21.1.3 Before You Begin

- Ensure you have either created a firewall rule to allow access from the WAN or turned the firewall off, otherwise the FTP will not function.
- Make sure the FTP service has not been disabled in the Remote Management screen.

21.1.4 Tool Examples

Using FTP or TFTP to Restore Configuration

This example shows you how to restore a previously saved configuration. Note that this function erases the current configuration before restoring a previous backup configuration; please do not attempt to restore unless you have a backup configuration file stored on disk.

FTP is the preferred method for restoring your current computer configuration to your device since FTP is faster. Please note that you must wait for the system to automatically restart after the file transfer is complete.

Do not interrupt the file transfer process as this may PERMANENTLY DAMAGE your device. When the Restore Configuration process is complete, the device automatically restarts.

Restore Using FTP Session Example

Figure 121 Restore Using FTP Session Example

```
ftp> put config.rom rom-0
200 Port command okay
150 Opening data connection for STOR rom-0
226 File received OK
221 Goodbye for writing flash
ftp: 16384 bytes sent in 0.06Seconds 273.07Kbytes/sec.
ftp>quit
```

Refer to [Section 21.1.2 on page 284](#) to read about configurations that disallow TFTP and FTP over WAN.

FTP and TFTP Firmware and Configuration File Uploads

These examples show you how to upload firmware and configuration files.

Do not interrupt the file transfer process as this may PERMANENTLY DAMAGE your device.

FTP is the preferred method for uploading the firmware and configuration. To use this feature, your computer must have an FTP client. The following sections give examples of how to upload the firmware and the configuration files.

FTP File Upload Command from the DOS Prompt Example

- 1 Launch the FTP client on your computer.
- 2 Enter "open", followed by a space and the IP address of your device.
- 3 Press [ENTER] when prompted for a username.
- 4 Enter your password as requested (the default is "1234").
- 5 Enter "bin" to set transfer mode to binary.
- 6 Use "put" to transfer files from the computer to the device, for example, "put firmware.bin ras" transfers the firmware on your computer (firmware.bin) to the device and renames it "ras". Similarly, "put config.rom rom-0" transfers the configuration file on your computer (config.rom) to the device and renames it "rom-0". Likewise "get rom-0 config.rom" transfers the configuration file on the device to your computer and renames it "config.rom." See earlier in this chapter for more information on filename conventions.
- 7 Enter "quit" to exit the ftp prompt.

FTP Session Example of Firmware File Upload

Figure 122 FTP Session Example of Firmware File Upload

```
331 Enter PASS command
Password:
230 Logged in
ftp> bin
200 Type I OK
ftp> put firmware.bin ras
200 Port command okay
150 Opening data connection for STOR ras
226 File received OK
ftp: 1103936 bytes sent in 1.10Seconds 297.89Kbytes/sec.
ftp> quit
```

More commands (found in GUI-based FTP clients) are listed in this chapter.

Refer to [Section 21.1.2 on page 284](#) to read about configurations that disallow TFTP and FTP over WAN.

TFTP File Upload

The device also supports the uploading of firmware files using TFTP (Trivial File Transfer Protocol) over LAN. Although TFTP should work over WAN as well, it is not recommended.

To use TFTP, your computer must have both telnet and TFTP clients. To transfer the firmware and the configuration file, follow the procedure shown next.

- 1 Use telnet from your computer to connect to the device and log in. Because TFTP does not have any security checks, the device records the IP address of the telnet client and accepts TFTP requests only from this address.
- 2 Enter the command “sys stdio 0” to disable the management idle timeout, so the TFTP transfer will not be interrupted. Enter “command sys stdio 5” to restore the five-minute management idle timeout (default) when the file transfer is complete.
- 3 Launch the TFTP client on your computer and connect to the device. Set the transfer mode to binary before starting data transfer.
- 4 Use the TFTP client (see the example below) to transfer files between the device and the computer. The file name for the firmware is “ras”.

Note that the telnet connection must be active and the device in CI mode before and during the TFTP transfer. For details on TFTP commands (see following example), please consult the documentation of your TFTP client program. For

UNIX, use “get” to transfer from the device to the computer, “put” the other way around, and “binary” to set binary transfer mode.

TFTP Upload Command Example

The following is an example TFTP command:

```
tftp [-i] host put firmware.bin ras
```

Where “i” specifies binary image transfer mode (use this mode when transferring binary files), “host” is the device’s IP address, “put” transfers the file source on the computer (firmware.bin – name of the firmware on the computer) to the file destination on the remote host (ras - name of the firmware on the device).

Commands that you may see in GUI-based TFTP clients are listed earlier in this chapter.

Using the FTP Commands to Back Up Configuration

- 1 Launch the FTP client on your computer.
- 2 Enter “open”, followed by a space and the IP address of your P-793H v2.
- 3 Press [ENTER] when prompted for a username.
- 4 Enter your password as requested (the default is “1234”).
- 5 Enter “bin” to set transfer mode to binary.
- 6 Use “get” to transfer files from the P-793H v2 to the computer, for example, “get rom-0 config.rom” transfers the configuration file on the P-793H v2 to your computer and renames it “config.rom”. See earlier in this chapter for more information on filename conventions.
- 7 Enter “quit” to exit the ftp prompt.

FTP Command Configuration Backup Example

This figure gives an example of using FTP commands from the DOS command prompt to save your device's configuration onto your computer.

Figure 123 FTP Session Example

```

331 Enter PASS command
Password:
230 Logged in
ftp> bin
200 Type I OK
ftp> get rom-0 zyxel.rom
200 Port command okay
150 Opening data connection for STOR ras
226 File received OK
ftp: 16384 bytes sent in 1.10Seconds 297.89Kbytes/sec.
ftp> quit

```

Configuration Backup Using GUI-based FTP Clients

The following table describes some of the commands that you may see in GUI-based FTP clients.

Table 100 General Commands for GUI-based FTP Clients

COMMAND	DESCRIPTION
Host Address	Enter the address of the host server.
Login Type	Anonymous. This is when a user I.D. and password is automatically supplied to the server for anonymous access. Anonymous logins will work only if your ISP or service administrator has enabled this option. Normal. The server requires a unique User ID and Password to login.
Transfer Type	Transfer files in either ASCII (plain text format) or in binary mode.
Initial Remote Directory	Specify the default remote directory (path).
Initial Local Directory	Specify the default local directory (path).

Backup Configuration Using TFTP

The P-793H v2 supports the up/downloading of the firmware and the configuration file using TFTP (Trivial File Transfer Protocol) over LAN. Although TFTP should work over WAN as well, it is not recommended.

To use TFTP, your computer must have both telnet and TFTP clients. To backup the configuration file, follow the procedure shown next.

- 1 Use telnet from your computer to connect to the P-793H v2 and log in. Because TFTP does not have any security checks, the P-793H v2 records the IP address of the telnet client and accepts TFTP requests only from this address.
- 2 Enter command `"sys stdio 0"` to disable the management idle timeout, so the TFTP transfer will not be interrupted. Enter command `"sys stdio 5"` to restore the five-minute management idle timeout (default) when the file transfer is complete.
- 3 Launch the TFTP client on your computer and connect to the P-793H v2. Set the transfer mode to binary before starting data transfer.
- 4 Use the TFTP client (see the example below) to transfer files between the P-793H v2 and the computer. The file name for the configuration file is `"rom-0"` (rom-zero, not capital o).

Note that the telnet connection must be active before and during the TFTP transfer. For details on TFTP commands (see following example), please consult the documentation of your TFTP client program. For UNIX, use `"get"` to transfer from the P-793H v2 to the computer and `"binary"` to set binary transfer mode.

TFTP Command Configuration Backup Example

The following is an example TFTP command:

```
tftp [-i] host get rom-0 config.rom
```

where `"i"` specifies binary image transfer mode (use this mode when transferring binary files), `"host"` is the P-793H v2 IP address, `"get"` transfers the file source on the P-793H v2 (`rom-0`, name of the configuration file on the P-793H v2) to the file destination on the computer and renames it `config.rom`.

Configuration Backup Using GUI-based TFTP Clients

The following table describes some of the fields that you may see in GUI-based TFTP clients.

Table 101 General Commands for GUI-based TFTP Clients

COMMAND	DESCRIPTION
Host	Enter the IP address of the P-793H v2. 192.168.1.1 is the P-793H v2's default IP address when shipped.
Send/ Fetch	Use "Send" to upload the file to the P-793H v2 and "Fetch" to back up the file on your computer.
Local File	Enter the path and name of the firmware file (*.bin extension) or configuration file (*.rom extension) on your computer.
Remote File	This is the filename on the P-793H v2. The filename for the firmware is "ras" and for the configuration file, is "rom-0".

Table 101 General Commands for GUI-based TFTP Clients (continued)

COMMAND	DESCRIPTION
Binary	Transfer the file in binary mode.
Abort	Stop transfer of the file.

Refer to [Section 21.1.2 on page 284](#) to read about configurations that disallow TFTP and FTP over WAN.

21.2 The Firmware Screen

Click **Maintenance > Tools** to open the **Firmware** screen. Follow the instructions in this screen to upload firmware to your P-793H v2. The upload process uses HTTP (Hypertext Transfer Protocol) and may take up to two minutes. After a successful upload, the system will reboot. See [Section 21.1.4 on page 285](#) for upgrading firmware using FTP/TFTP commands.

Do NOT turn off the P-793H v2 while firmware upload is in progress!

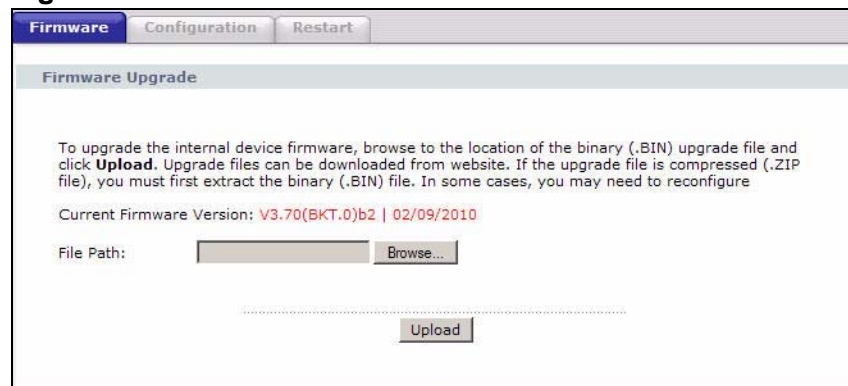
Figure 124 Maintenance > Tools > Firmware

The following table describes the labels in this screen.

Table 102 Maintenance > Tools > Firmware

LABEL	DESCRIPTION
Current Firmware Version	This is the present Firmware version and the date created.
File Path	Type in the location of the file you want to upload in this field or click Browse ... to find it.

Table 102 Maintenance > Tools > Firmware (continued)

LABEL	DESCRIPTION
Browse...	Click this to find the .bin file you want to upload. Remember that you must decompress compressed (.zip) files before you can upload them.
Upload	Click this to begin the upload process. This process may take up to two minutes.

After you see the **Firmware Upload in Progress** screen, wait two minutes before logging into the P-793H v2 again.

Figure 125 Firmware Upload In Progress

The P-793H v2 automatically restarts in this time causing a temporary network disconnect. In some operating systems, you may see the following icon on your desktop.

Figure 126 Network Temporarily Disconnected

After two minutes, log in again and check your new firmware version in the **Status** screen.

If the upload was not successful, the following screen will appear. Click **Return** to go back to the **Firmware** screen.

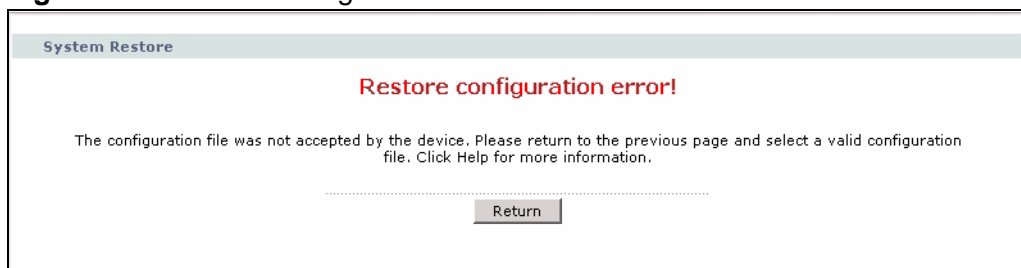
Figure 127 Error Message

21.3 The Configuration Screen

See [Section 21.1.4 on page 285](#) for transferring configuration files using FTP/TFTP commands.

Click **Maintenance > Tools > Configuration**. Information related to factory defaults, backup configuration, and restoring configuration appears in this screen, as shown next.

Figure 128 Maintenance > Tools > Configuration

The screenshot shows a web interface with three tabs: Firmware, Configuration (selected), and Restart. The main content area is divided into three sections:

- Backup Configuration:** Contains the text "Click **Backup** to save the current configuration to your computer." and a "Backup" button.
- Restore Configuration:** Contains the text "To restore a previously saved configuration file on your computer to the Prestige, please type a location for storing the configuration file or click **Browse** to look for one, and then click **Upload**." Below this is a "File Path:" label, a text input field, a "Browse..." button, and an "Upload" button.
- Reset to Factory Default Settings:** Contains the text "Click **Reset** to clear all user-entered configuration and return the Prestige to the factory default settings." Below this is the text "The following default settings would become effective after click **Reset**" followed by a list of settings: "Password :1234", "Lan IP : 192.168.1.1", and "DHCP : Server .". At the bottom is a "Reset" button.

Backup Configuration

Backup Configuration allows you to back up (save) the P-793H v2's current configuration to a file on your computer. Once your P-793H v2 is configured and functioning properly, it is highly recommended that you back up your configuration file before making configuration changes. The backup configuration file will be useful in case you need to return to your previous settings.

Click **Backup** to save the P-793H v2's current configuration to your computer.

Restore Configuration

Restore Configuration allows you to upload a new or previously saved configuration file from your computer to your P-793H v2.

Table 103 Restore Configuration

LABEL	DESCRIPTION
File Path	Type in the location of the file you want to upload in this field or click Browse ... to find it.
Browse...	Click this to find the file you want to upload. Remember that you must decompress compressed (.ZIP) files before you can upload them.
Upload	Click this to begin the upload process.

Do not turn off the P-793H v2 while configuration file upload is in progress.

After you see a “restore configuration successful” screen, you must then wait one minute before logging into the P-793H v2 again.

Figure 129 Configuration Upload Successful

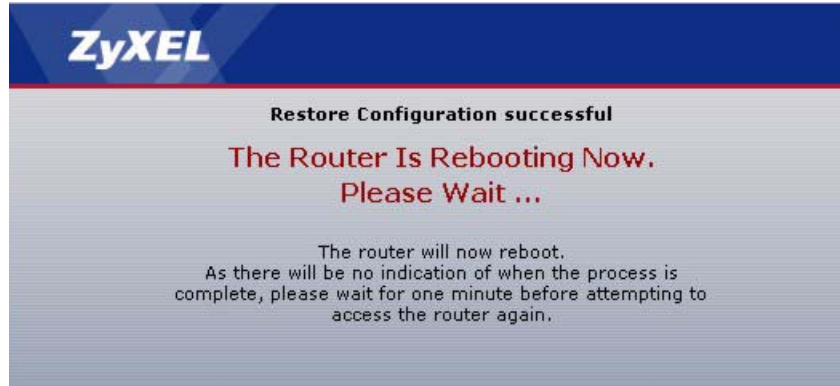

The P-793H v2 automatically restarts in this time causing a temporary network disconnect. In some operating systems, you may see the following icon on your desktop.

Figure 130 Network Temporarily Disconnected



If you uploaded the default configuration file you may need to change the IP address of your computer to be in the same subnet as that of the default device IP address (192.168.1.1). See [Appendix C on page 429](#) for details on how to set up your computer’s IP address.

If the upload was not successful, the following screen will appear. Click **Return** to go back to the **Configuration** screen.

Figure 131 Configuration Upload Error

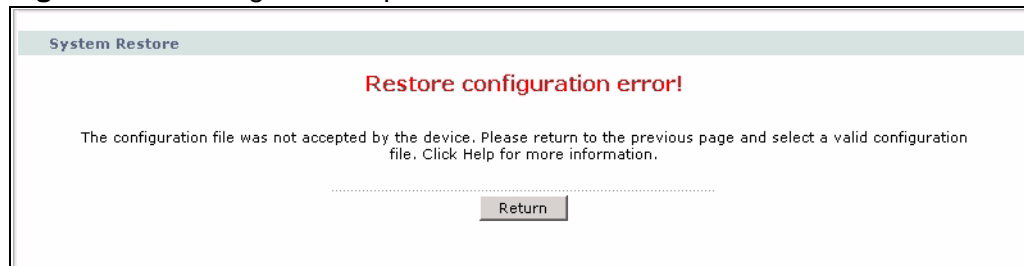

Reset to Factory Defaults

Click the **Reset** button to clear all user-entered configuration information and return the P-793H v2 to its factory defaults. The following warning screen appears.

Figure 132 Reset Warning Message



Figure 133 Reset In Process Message



You can also press the **RESET** button on the rear panel to reset the factory defaults of your P-793H v2. Refer to [Section 1.5 on page 41](#) for more information on the **RESET** button.

21.4 The Restart Screen

System restart allows you to reboot the P-793H v2 remotely without turning the power off. You may need to do this if the P-793H v2 hangs, for example.

Click **Maintenance > Tools > Restart**. Click **Restart** to have the P-793H v2 reboot. This does not affect the P-793H v2's configuration.

Figure 134 Maintenance > Tools > Restart



Diagnostic

22.1 Overview

These read-only screens display information to help you identify problems with the P-793H v2.

22.1.1 What You Can Do in the Diagnostic Screens

- Use the **General** screen ([Section 22.2 on page 297](#)) to ping an IP address.
- Use the **DSL Line** screen ([Section 22.3 on page 298](#)) to view the DSL line statistics and reset the ADSL line.

22.2 The General Diagnostic Screen

Use this screen to ping an IP address. Click **Maintenance > Diagnostic** to open the screen shown next.

Figure 135 Maintenance > Diagnostic > General

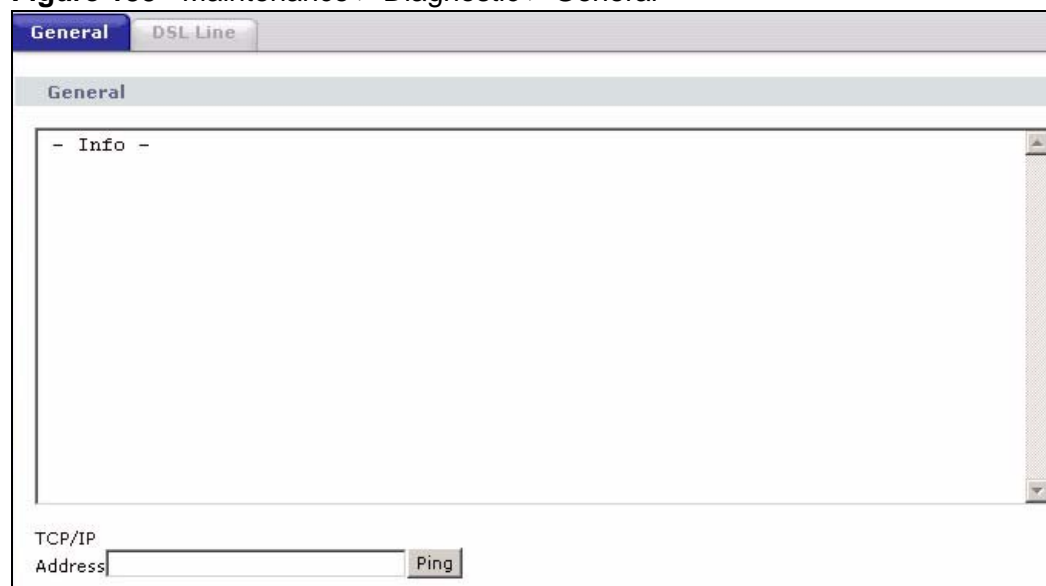

The following table describes the fields in this screen.

Table 104 Maintenance > Diagnostic > General

LABEL	DESCRIPTION
TCP/IP Address	Type the IP address of a computer that you want to ping in order to test a connection.
Ping	Click this to ping the IP address that you entered.

22.3 The DSL Line Diagnostic Screen

Use this screen to view the DSL line statistics and reset the ADSL line. Click **Maintenance > Diagnostic > DSL Line** to open the screen shown next.

Figure 136 Maintenance > Diagnostic > DSL Line

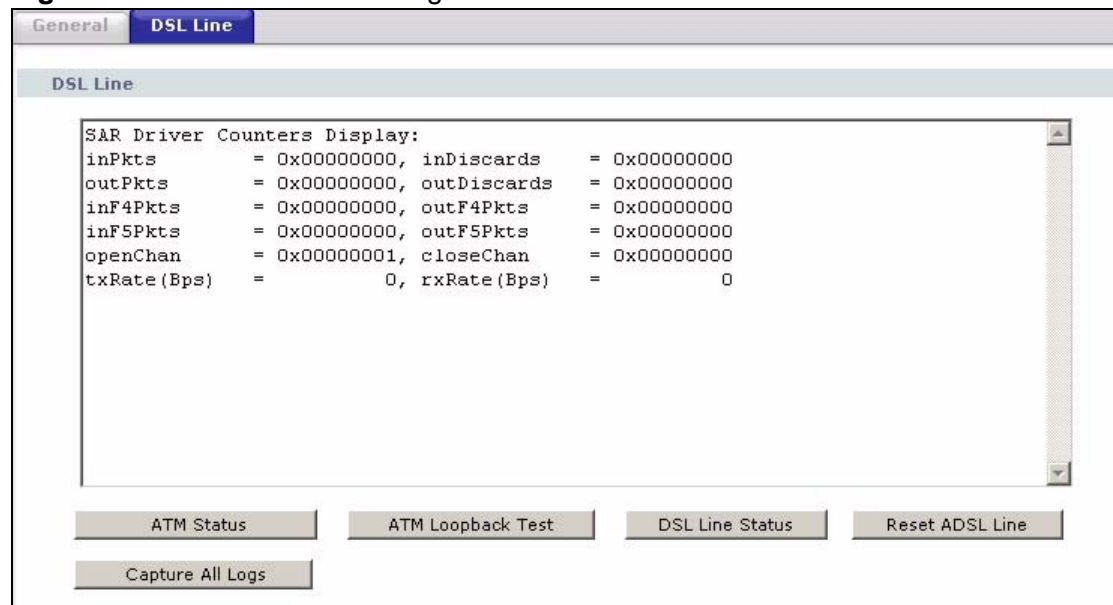

The following table describes the fields in this screen.

Table 105 Maintenance > Diagnostic > DSL Line

LABEL	DESCRIPTION
ATM Status	<p>Click this to view your DSL connection's Asynchronous Transfer Mode (ATM) statistics. ATM is a networking technology that provides high-speed data transfer. ATM uses fixed-size packets of information called cells. With ATM, a high QoS (Quality of Service) can be guaranteed.</p> <p>The (Segmentation and Reassembly) SAR driver translates packets into ATM cells. It also receives ATM cells and reassembles them into packets.</p> <p>These counters are set back to zero whenever the device starts up.</p> <p>inPkts is the number of good ATM cells that have been received.</p> <p>inDiscards is the number of received ATM cells that were rejected.</p> <p>outPkts is the number of ATM cells that have been sent.</p> <p>outDiscards is the number of ATM cells sent that were rejected.</p> <p>inF4Pkts is the number of ATM Operations, Administration, and Management (OAM) F4 cells that have been received. See ITU recommendation I.610 for more on OAM for ATM.</p> <p>outF4Pkts is the number of ATM OAM F4 cells that have been sent.</p> <p>inF5Pkts is the number of ATM OAM F5 cells that have been received.</p> <p>outF5Pkts is the number of ATM OAM F5 cells that have been sent.</p> <p>openChan is the number of times that the P-793H v2 has opened a logical DSL channel.</p> <p>closeChan is the number of times that the P-793H v2 has closed a logical DSL channel.</p> <p>txRate is the number of bytes transmitted per second.</p> <p>rxRate is the number of bytes received per second.</p>
ATM Loopback Test	<p>Click this to start the ATM loopback test. Make sure you have configured at least one PVC with proper VPis/VCIs before you begin this test. The P-793H v2 sends an OAM F5 packet to the DSLAM/ATM switch and then returns it (loops it back) to the P-793H v2. The ATM loopback test is useful for troubleshooting problems with the DSLAM and ATM network.</p>

Table 105 Maintenance > Diagnostic > DSL Line (continued)

LABEL	DESCRIPTION
DSL Line Status	<p>Click this to view statistics about the DSL connections.</p> <p>noise margin downstream is the signal to noise ratio for the downstream part of the connection (coming into the P-793H v2 from the ISP). It is measured in decibels. The higher the number the more signal and less noise there is.</p> <p>output power upstream is the amount of power (in decibels) that the P-793H v2 is using to transmit to the ISP.</p> <p>attenuation downstream is the reduction in amplitude (in decibels) of the DSL signal coming into the P-793H v2 from the ISP.</p> <p>Discrete Multi-Tone (DMT) modulation divides up a line's bandwidth into sub-carriers (sub-channels) of 4.3125 KHz each called tones. The rest of the display is the line's bit allocation. This is displayed as the number (in hexadecimal format) of bits transmitted for each tone. This can be used to determine the quality of the connection, whether a given sub-carrier loop has sufficient margins to support certain ADSL transmission rates, and possibly to determine whether particular specific types of interference or line attenuation exist. Refer to the ITU-T G.992.1 recommendation for more information on DMT.</p> <p>The better (or shorter) the line, the higher the number of bits transmitted for a DMT tone. The maximum number of bits that can be transmitted per DMT tone is 15. There will be some tones without any bits as there has to be space between the upstream and downstream channels.</p>
Reset ADSL Line	<p>Click this to reinitialize the ADSL line. The large text box above then displays the progress and results of this operation, for example:</p> <pre data-bbox="540 1119 967 1245">"Start to reset ADSL Loading ADSL modem F/W... Reset ADSL Line Successfully!"</pre>
Capture All Logs	<p>Click this to display information and statistics about your P-793H v2's ATM statistics, DSL connection statistics, DHCP settings, firmware version, WAN and gateway IP address, VPI/VCI and LAN IP address.</p>

Introducing the SMT

The System Management Terminal (SMT) provides a text-based, menu-driven console to manage the P-793H v2. This chapter describes how to access the SMT and then provides an overview of its menus.

23.1 Accessing the SMT

Use Telnet to access the SMT. Follow these steps.

- 1 In Windows, click **Start** > **Run**.
- 2 Type "telnet [w.x.y.z](#)", and click **OK**.
[w.x.y.z](#) is the IP address of the P-793H v2; the default address is 192.168.1.1.
The P-793H v2 prompts you for the password.

Figure 137 Login Screen

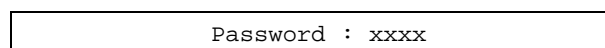

```
Password : xxxx
```

- 3 Enter the password. The default password is 1234. As you type the password, the screen displays an asterisk "*" for each character you type.
- 4 After you enter the password, the SMT main menu appears, as shown next.

Note: Use menu 23.1 to change the password.

Figure 138 SMT Main Menu

```

Copyright (c) 1994 - 2009 ZyXEL Communications Corp.

P-793H v2 Main Menu

Getting Started
  1. General Setup
  2. WAN Setup
  3. LAN Setup
  4. Internet Access Setup

Advanced Applications
  11. Remote Node Setup
  12. Static Routing Setup
  15. NAT Setup

Advanced Management
  21. Filter and Firewall Setup
  22. SNMP Configuration
  23. System Password
  24. System Maintenance
  26. Schedule Setup
  99. Exit

Enter Menu Selection Number:

```

Note: There is an inactivity timeout, and the default value is ten minutes. If there is no activity for longer than this, your P-793H v2 will automatically log you out. You will then have to telnet into the P-793H v2 again. You can use the web configurator or the CLI commands (menu 24.8) to change the inactivity timeout period.

23.2 SMT Menu Items

The following table provides an overview of each menu item.

Table 106 Main Menu Summary

MENU	FUNCTION
1 General Setup	Use this menu to set up device mode, dynamic DNS and administrative information.
2 WAN Setup	Use this menu to configure the DSL connection, and traffic redirect interface.
3 LAN Setup	Use this to apply LAN filters, configure LAN DHCP and TCP/IP settings, and to allow or block layer-2 traffic between each pair of ports.
4 Internet Access Setup	Use this menu to configure your Internet connection.

Table 106 Main Menu Summary

MENU	FUNCTION
11 Remote Node Setup	Use this menu to configure detailed remote node settings (for example, your ISP is a remote node) as well as apply filters.
12 Static Routing Setup	Use this menu to configure IP and bridge (MAC) static routes.
15 NAT Setup	Use this menu to configure Network Address Translation (NAT) on the P-793H v2.
21 Filter and Firewall Setup	Use this menu to configure filters and to activate or deactivate the firewall.
22 SNMP Configuration	Use this menu to configure SNMP.
23 System Password	Use this menu to change your password.
24 System Maintenance	Use this menu for comprehensive system maintenance, from looking at the system status to uploading firmware. You can also access the Command Interface (CI).
26 Schedule Setup	Use this menu to configure schedule sets.
99 Exit	Use this menu to exit the SMT.

The following table gives you an overview of the various SMT menus.

Table 107 SMT Menus Overview

MENUS	SUB MENUS		
1 General Setup	1.1 Configure Dynamic DNS		
2 WAN Setup	2.1 Traffic Redirect Setup		
3 LAN Setup	3.1 LAN Port Filter Setup		
	3.2 TCP/IP and DHCP Setup	3.2.1 IP Alias Setup	
4 Internet Access Setup			
11 Remote Node Setup	11.1 Remote Node Profile	11.1.3 Remote Node Network Layer Options	
		11.1.5 Remote Node Filter	
		11.1.6 Remote Node ATM Layer Options	
12 Static Route Setup	12.1 IP Static Route Setup	12.1.1 Edit IP Static Route	
	12.3 Bridge Static Route Setup	12.3.1 Edit Bridge Static Route	
15 NAT Setup	15.1 Address Mapping Sets	15.1.x Address Mapping Rules	15.1.x.x Address Mapping Rule
	15.2 NAT Server Sets	15.2.x NAT Server Setup	

Table 107 SMT Menus Overview (continued)

MENUS	SUB MENUS		
21 Filter and Firewall Setup	21.1 Filter Set Configuration	21.1.x Filter Rules Summary	21.1.x.x Generic Filter Rule
			21.1.x.x TCP/IP Filter Rule
	21.2 Firewall Setup		
22 SNMP Configuration			
23 System Password			
24 System Maintenance	24.1 System Maintenance - Status		
	24.2 System Information and Console Port Speed	24.2.1 System Maintenance - Information	
		24.2.2 System Maintenance - Change Console Port Speed	
	24.3 System Maintenance - Log and Trace	24.3.1 View Error Log	
		24.3.2 System Maintenance - UNIX Syslog	
	24.4 System Maintenance - Diagnostic		
	24.5 Backup Configuration		
	24.6 Restore Configuration		
	24.7 System Maintenance - Upload Firmware	24.7.1 System Maintenance - Upload System Firmware	
		24.7.2 System Maintenance - Upload System Configuration File	
	24.8 Command Interpreter Mode		
	24.9 System Maintenance - Call Control ²³	24.9.1 Budget Management	
	24.10 System Maintenance - Time and Date Setting		
24.11 Remote Management Control			
26 Schedule Setup	26.1 Schedule Set Setup		

23.3 Navigating the SMT Interface

You should be familiar with the following operations before you try to use the SMT to modify the configuration.

Table 108 Main Menu Commands

OPERATION	KEYSTROKE	DESCRIPTION
Move down to another menu	[ENTER]	To move forward to a submenu, type in the number of the desired submenu and press [ENTER].
Move up to a previous menu	[ESC]	Press [ESC] to move back to the previous menu.
Move to a "hidden" menu	Press [SPACE BAR] to change No to Yes then press [ENTER].	Fields beginning with "Edit" lead to hidden menus and have a default setting of No . Press [SPACE BAR] once to change No to Yes , then press [ENTER] to go to the "hidden" menu.
Move the cursor	[ENTER] or [UP]/[DOWN] arrow keys.	Within a menu, press [ENTER] to move to the next field. You can also use the [UP]/[DOWN] arrow keys to move to the previous and the next field, respectively.
Entering information	Type in or press [SPACE BAR], then press [ENTER].	You need to fill in two types of fields. The first requires you to type in the appropriate information. The second allows you to cycle through the available choices by pressing [SPACE BAR].
Required fields	<?> or ChangeMe	All fields with the symbol <?> must be filled in order to be able to save the new configuration. All fields with ChangeMe must not be left blank in order to be able to save the new configuration.
N/A fields	<N/A>	Some of the fields in the SMT will show a <N/A>. This symbol refers to an option that is Not Applicable.
Save your configuration	[ENTER]	Save your configuration by pressing [ENTER] at the message "Press ENTER to confirm or ESC to cancel". Saving the data on the screen will take you, in most cases to the previous menu.
Exit the SMT	Type 99, then press [ENTER].	Type 99 at the main menu prompt and press [ENTER] to exit the SMT interface.

General Setup

Use this menu to set up device mode, dynamic DNS and administrative information.

24.1 Configuring General Setup

- 1 Enter 1 in the main menu to open **Menu 1 - General Setup**.
- 2 The **Menu 1 - General Setup** screen appears, as shown next. Fill in the required fields.

Figure 139 Menu 1: General Setup

```

Menu 1 - General Setup

System Name= P-793H v2
Location=
Contact Person's Name=
Domain Name=
First DNS Server= 0.0.0.0
Secondary DNS Server= 0.0.0.0
Third DNS Server= 0.0.0.0
Edit Dynamic DNS= No

Route IP= Yes
Bridge= No

```

The following table describes the fields in this menu.

Table 109 Menu 1: General Setup

FIELD	DESCRIPTION
System Name	Choose a descriptive name for identification purposes. It is recommended you enter your computer's "Computer name" in this field. This name can be up to 30 alphanumeric characters long. Spaces are not allowed, but dashes "-" and underscores "_" are accepted.
Location	Enter a descriptive name for the place where the P-793H v2 is located. You can enter up to 31 characters, or you can leave this field blank.

Table 109 Menu 1: General Setup (continued)

FIELD	DESCRIPTION
Contact Person's Name	Enter the name of the person to contact for questions about the P-793H v2. You can enter up to 30 characters, or you can leave this field blank.
Domain Name	Enter the domain name (if you know it) here. If you leave this field blank, the ISP may assign a domain name via DHCP. You can go to menu 24.8 and type "sys domain name" to see the current domain name used by your router. The domain name entered by you is given priority over the ISP assigned domain name. If you want to clear this field just press [SPACE BAR] and then [ENTER].
Edit Dynamic DNS	Press [SPACE BAR] and then [ENTER] to select Yes or No (default). Select Yes to configure Menu 1.1: Configure Dynamic DNS discussed next.
Route IP	Select Yes to enable IP-based routing in the P-793H v2. This is not effective for a specific remote node unless you enable IP-based routing in the remote node too. See Menu 11.1: Remote Node Profile (nodes 1-7) in Section 28.3 on page 326 . You should enable Route IP , Bridge , or both in this screen. If you disable Route IP and Bridge , the device does not send traffic between the LAN ports and remote node.
Bridge345	If Route IP is Yes , select Yes in this field to enable bridging in the P-793H v2 for protocols that are not supported by IP-based routing (for example, SNA). If Route IP is No , select Yes in this field to enable bridging in the P-793H v2 for all protocols. In either case, this setting is not effective for a specific remote node unless you enable bridging in the remote node too. See Menu 11.1: Remote Node Profile (nodes 1-7) in Section 28.3 on page 326 . You should enable Route IP , Bridge , or both in this screen. If you disable Route IP and Bridge , the device does not send traffic between the LAN ports and remote node.
When you have completed this menu, press [ENTER] at the prompt "Press ENTER to Confirm..." to save your configuration, or press [ESC] at any time to cancel.	

24.1.1 Configuring Dynamic DNS

To configure Dynamic DNS, set the P-793H v2 to router mode in menu 1 or in the **MAINTENANCE Device Mode** screen and go to **Menu 1 - General Setup** and

press [SPACE BAR] to select **Yes** in the **Edit Dynamic DNS** field. Press [ENTER] to display **Menu 1.1 - Configure Dynamic DNS** (shown next).

Figure 140 Menu 1.1: Configure Dynamic DNS

```

Menu 1.1 - Configure Dynamic DNS

Service Provider= WWW.DynDNS.ORG
Active= No
DDNSType= DynamicDNS
Host 1=
Host 2=
Host 3=
Username=
Password= *****
Enable Wildcard Option= No
Enable Off Line Option= N/A
IP Address Update Policy:
  DDNS Server Auto Detect IP Address= No
  Use Specified IP Address= No
  Use IP Address= N/A

```

Follow the instructions in the next table to configure Dynamic DNS parameters.

Table 110 Menu 1.1: Configure Dynamic DNS

FIELD	DESCRIPTION
Service Provider	This is the name of your Dynamic DNS service provider.
Active	Press [SPACE BAR] to select Yes and then press [ENTER] to make dynamic DNS active.
DDNSType	Press [SPACE BAR] and then [ENTER] to select DynamicDNS if you have the Dynamic DNS service. Select StaticDNS if you have the Static DNS service. Select CustomDNS if you have the Custom DNS service.
Host 1-3	Enter up to three host names in these fields.
Username	Enter your user name.
Password	Enter the password assigned to you.
Enable Wildcard Option	Your P-793H v2 supports DYNDNS Wildcard. Press [SPACE BAR] and then [ENTER] to select Yes or No . This field is N/A when you choose DDNS client as your service provider.
Enable Off Line Option	This field is only available when CustomDNS is selected in the DDNS Type field. Press [SPACE BAR] and then [ENTER] to select Yes . When Yes is selected, http://www.dyndns.org/ traffic is redirected to a URL that you have previously specified (see www.dyndns.org for details).

Table 110 Menu 1.1: Configure Dynamic DNS

FIELD	DESCRIPTION
IP Address Update Policy:	<p>You can select Yes in either the DDNS Server Auto Detect IP Address field (recommended) or the Use Specified IP Address field, but not both.</p> <p>With the DDNS Server Auto Detect IP Address and Use Specified IP Address fields both set to No, the DDNS server automatically updates the IP address of the host name(s) with the P-793H v2's WAN IP address.</p> <p>DDNS does not work with a private IP address. When both fields are set to No, the P-793H v2 must have a public WAN IP address in order for DDNS to work.</p>
DDNS Server Auto Detect IP Address	<p>Only select this option when there are one or more NAT routers between the P-793H v2 and the DDNS server. Press [SPACE BAR] to select Yes and then press [ENTER] to have the DDNS server automatically detect and use the IP address of the NAT router that has a public IP address.</p> <p>Note: The DDNS server may not be able to detect the proper IP address if there is an HTTP proxy server between the P-793H v2 and the DDNS server.</p>
Use Specified IP Address	<p>Press [SPACE BAR] to select Yes and then press [ENTER] to update the IP address of the host name(s) to the IP address specified below.</p> <p>Only select Yes if the P-793H v2 uses or is behind a static public IP address.</p>
Use IP Address	<p>Enter the static public IP address if you select Yes in the Use Specified IP Address field.</p>
<p>When you have completed this menu, press [ENTER] at the prompt "Press ENTER to Confirm..." to save your configuration, or press [ESC] at any time to cancel.</p>	

WAN Setup

Use this menu to configure the DSL connection, and traffic redirect interface.

25.1 WAN Setup

From the main menu, enter 2 to open menu 2.

Figure 141 Menu 2: WAN Setup

```
Menu 2 - WAN Setup

Service Mode= 2wire                DSL Mode = ATM
Service Type= Server
Rate Adaption= Disable             Rate Adaption= N/A
Transfer Max Rate(Kbps)= 5696      Transfer Max Rate(Kbps)= N/A
Transfer Min Rate(Kbps)= 192       Transfer Min Rate(Kbps)= N/A
Standard Mode= ETSI(ANNEX_B)      Standard Mode= N/A
Wan Backup Setup:
Check Mechanism = ICMP
Check WAN IP Address1 = 0.0.0.0
Check WAN IP Address2 = 0.0.0.0
Check WAN IP Address3 = 0.0.0.0
  KeepAlive Fail Tolerance = 31
  Recovery Interval(sec) = 3
  ICMP Timeout(sec) = 9677
Traffic Redirect = No
```

The following table describes the fields in this screen.

Table 111 Menu 2: WAN Setup

FIELD	DESCRIPTION
Service Mode	Press [SPACE BAR] to indicate whether the P-793H v2 should use 2-wire or 4-wire mode for the DSL connection. This is related to the phone line you use and affects the maximum speed of the connection. In 2-wire mode, the maximum data rate is up to 5.69 Mbps, while in 4-wire mode, the maximum data rate us up to 11.38 Mbps. See Section 25.1.1 on page 313 for information on 2wire-2line service mode.
DSL Mode	Press [SPACE BAR] to select the transfer mode you want to use. PTM (Packet Transfer Mode): The P-793H v2 uses the SHDSL technology for data transmission over the DSL port. ATM (Asynchronous Transfer Mode): The P-793H v2 uses the ADSL technology for data transmission over the DSL port.
Service Type	Press [SPACE BAR] to indicate whether the P-793H v2 is the server or the client in the DSL connection. Select Server if this P-793H v2 is the server in a point-to-point application. (See Chapter 5 on page 67 .) Otherwise, select Client .
Rate Adaption	This field is configurable if Service Type is Server . Press [SPACE BAR] to let the P-793H v2 adjust the speed of its connection to that of the other device.
Transfer Max Rate(Kbps)	This field is enabled if Service Type is Server . Press [SPACE BAR] to set the maximum rate at which the P-793H v2 sends and receives information. If you enable Rate Adaption , the P-793H v2 adjusts to the speed of the other device and may exceed this rate.
Transfer Min Rate(Kbps)	This field is enabled if Service Type is Server . Press [SPACE BAR] to set the minimum rate at which the P-793H v2 sends and receives information. If you enable Rate Adaption , the P-793H v2 adjusts to the speed of the other device and may transfer information at less than this rate.
Standard Mode	This field is enabled if Service Type is Server . Press [SPACE BAR] to select the operational mode the P-793H v2 uses in the DSL connection.
Wan Backup Setup	
Check Mechanism	Select the method that the P-793H v2 uses to check the DSL connection. Select DSL Link to have the P-793H v2 check if the connection to the DSLAM is up. Select ICMP to have the P-793H v2 periodically ping the IP addresses configured in the Check WAN IP Address fields.
Check WAN IP Address1 Check WAN IP Address2 Check WAN IP Address3	Configure this field to test your P-793H v2's WAN accessibility. Type the IP address of up to three reliable, nearby computers (for example, your ISP's DNS server address). Note: If you activate either traffic redirect or dial backup, you must configure at least one IP address here. When using a WAN backup connection, the P-793H v2 periodically pings the addresses configured here and uses the other WAN backup connection (if configured) if there is no response.

Table 111 Menu 2: WAN Setup (continued)

FIELD	DESCRIPTION
KeepAlive Fail Tolerance	Type the number of times (2 recommended) that your P-793H v2 may ping the IP addresses configured in the Check WAN IP Address field without getting a response before switching to a WAN backup connection (or a different WAN backup connection).
Recovery Interval(sec)	When the P-793H v2 is using a lower priority connection (usually a WAN backup connection), it periodically checks to whether or not it can use a higher priority connection. Type the number of seconds (30 recommended) for the P-793H v2 to wait between checks. Allow more time if your destination IP address handles lots of traffic.
ICMP Timeout(sec)	Type the number of seconds (3 recommended) for your P-793H v2 to wait for a ping response from one of the IP addresses in the Check WAN IP Address field before timing out the request. The WAN connection is considered "down" after the P-793H v2 times out the number of times specified in the Fail Tolerance field. Use a higher value in this field if your network is busy or congested.
Traffic Redirect	Press [SPACE BAR] to select Yes and then press [ENTER] to activate traffic redirect and to edit its settings.
When you have completed this menu, press [ENTER] at the prompt "Press ENTER to Confirm..." to save your configuration, or press [ESC] at any time to cancel.	

25.1.1 2wire-2line Service Mode

From the main menu, enter 2 to open menu 2, then select **2wire-2line** in the **Service Mode** field to see the screen as shown below.

Figure 142 Menu 2: 2wire-2line Service Mode

Menu 2 - WAN Setup	
Service Mode= 2wire-2line	
Service Type= N/A	
Rate Adaption= Disable	Rate Adaption= Enable
Transfer Max Rate(Kbps)= 4480	Transfer Max Rate(Kbps)= 5696
Transfer Min Rate(Kbps)= 4480	Transfer Min Rate(Kbps)= 3200
Standard Mode= ANSI(ANNEX_A)	Standard Mode= ANSI(ANNEX_A)
Wan Backup Setup:	
Check Mechanism = DSL Link	
Check WAN IP Address1 = 0.0.0.0	
Check WAN IP Address2 = 0.0.0.0	
Check WAN IP Address3 = 0.0.0.0	
KeepAlive Fail Tolerance = 0	
Recovery Interval(sec) = 0	
ICMP Timeout(sec) = 0	
Traffic Redirect = No	

The following table describes the fields in this screen.

Table 112 Menu 2: 2wire-2line Service Mode

FIELD	DESCRIPTION
Service Mode	Press [SPACE BAR] to select 2wire-2line service mode. This means you are establishing a point-to-point connection. In 2wire-2line mode, the maximum data rate is up to 5.69 Mbps for each DSL connection.
Service Type	The P-793H v2 automatically acts as a server in 2wire-2line mode.
Rate Adaption	The field on the left refers to DSL 1 connection and the field on the right refers to DSL 2 connection. Press [SPACE BAR] to let the P-793H v2 adjust the speed of its connection to that of the other device.
Transfer Max Rate(Kbps)	The field on the left refers to DSL 1 connection and the field on the right refers to DSL 2 connection. Press [SPACE BAR] to set the maximum rate at which the P-793H v2 sends and receives information. If you enable Rate Adaption , the P-793H v2 adjusts to the speed of the other device and may exceed this rate.
Transfer Min Rate(Kbps)	The field on the left refers to DSL 1 connection and the field on the right refers to DSL 2 connection. Press [SPACE BAR] to set the minimum rate at which the P-793H v2 sends and receives information. If you enable Rate Adaption , the P-793H v2 adjusts to the speed of the other device and may transfer information at less than this rate.
Standard Mode	The field on the left refers to DSL 1 connection and the field on the right refers to DSL 2 connection. Press [SPACE BAR] to select the operational mode the P-793H v2 uses in the DSL connection.
Wan Backup Setup	
Check Mechanism	Select the method that the P-793H v2 uses to check the DSL connection. Select DSL Link to have the P-793H v2 check if the connection to the DSLAM is up. Select ICMP to have the P-793H v2 periodically ping the IP addresses configured in the Check WAN IP Address fields.
Check WAN IP Address1 Check WAN IP Address2 Check WAN IP Address3	Configure this field to test your P-793H v2's WAN accessibility. Type the IP address of up to three reliable, nearby computers (for example, your ISP's DNS server address). Note: If you activate either traffic redirect or dial backup, you must configure at least one IP address here. When using a WAN backup connection, the P-793H v2 periodically pings the addresses configured here and uses the other WAN backup connection (if configured) if there is no response.
KeepAlive Fail Tolerance	Type the number of times (2 recommended) that your P-793H v2 may ping the IP addresses configured in the Check WAN IP Address field without getting a response before switching to a WAN backup connection (or a different WAN backup connection).
Recovery Interval(sec)	When the P-793H v2 is using a lower priority connection (usually a WAN backup connection), it periodically checks to whether or not it can use a higher priority connection. Type the number of seconds (30 recommended) for the P-793H v2 to wait between checks. Allow more time if your destination IP address handles lots of traffic.

Table 112 Menu 2: 2wire-2line Service Mode (continued)

FIELD	DESCRIPTION
ICMP Timeout(sec)	Type the number of seconds (3 recommended) for your P-793H v2 to wait for a ping response from one of the IP addresses in the Check WAN IP Address field before timing out the request. The WAN connection is considered "down" after the P-793H v2 times out the number of times specified in the Fail Tolerance field. Use a higher value in this field if your network is busy or congested.
Traffic Redirect	This feature is disabled in 2wire-2line service mode.
When you have completed this menu, press [ENTER] at the prompt "Press ENTER to Confirm..." to save your configuration, or press [ESC] at any time to cancel.	

25.2 Configuring Traffic Redirect

From the main menu, in menu 2, select **Yes** in **Traffic Redirect**, and then press [ENTER].

Figure 143 Menu 2.1: Traffic Redirect Setup

<pre> Menu 2.1 - Traffic Redirect Setup Active= No Configuration: Backup Gateway IP Address= 0.0.0.0 Metric= 15 </pre>

The following table describes the fields in this menu.

Table 113 Menu 2.1: Traffic Redirect Setup

FIELD	DESCRIPTION
Active	Use this field to turn the traffic redirect feature on (Yes) or off (No).
Configuration	
Backup Gateway IP Address	Type the IP address of your backup gateway in dotted decimal notation. The P-793H v2 automatically forwards traffic to this IP address if the P-793H v2's Internet connection terminates.
Metric	This field sets this route's priority among the routes the P-793H v2 uses. The metric represents the "cost of transmission". A router determines the best route for transmission by choosing a path with the lowest "cost". RIP routing uses hop count as the measurement of cost, with a minimum of "1" for directly connected networks. The number must be between "1" and "15"; a number greater than "15" means the link is down. The smaller the number, the lower the "cost".
When you have completed this menu, press [ENTER] at the prompt "Press ENTER to Confirm..." to save your configuration, or press [ESC] at any time to cancel.	

LAN Setup

Use this to apply LAN filters, configure LAN DHCP and TCP/IP settings, and to activate or deactivate VLAN on each LAN port.

26.1 Accessing the LAN Menus

From the main menu, enter 3 to open **Menu 3 - LAN Setup**.

Figure 144 Menu 3: LAN Setup

```
Menu 3 - LAN Setup

1. LAN Port Filter Setup
2. TCP/IP and DHCP Setup
```

26.2 LAN Port Filter Setup

This menu allows you to specify the filter sets that you wish to apply to the LAN traffic. You seldom need to filter the LAN traffic, however, the filter sets may be useful to block certain packets, reduce traffic and prevent security breaches.

Figure 145 Menu 3.1: LAN Port Filter Setup

```
Menu 3.1 - LAN Port Filter Setup

Input Filter Sets:
  protocol filters=
  device filters=
Output Filter Sets:
  protocol filters=
  device filters=
```

26.3 TCP/IP and DHCP Setup Menu

From the main menu, enter 3 to open **Menu 3 - LAN Setup** to configure TCP/IP (RFC 1155) and DHCP setup. From menu 3, select the submenu option **TCP/IP and DHCP Setup** and press [ENTER]. The screen now displays **Menu 3.2 - TCP/IP and DHCP Ethernet Setup**, as shown next. Not all fields are available on all models.

Figure 146 Menu 3.2: TCP/IP and DHCP Ethernet Setup

```

Menu 3.2 - TCP/IP and DHCP Setup

DHCP= Server
Client IP Pool Starting Address= 192.168.1.33
Size of Client IP Pool= 32
First DNS Server= 0.0.0.0
Secondary DNS Server= 0.0.0.0
Third DNS Server= 0.0.0.0
DHCP Server Address= N/A
TCP/IP Setup:
  IP Address= 192.168.1.1
  IP Subnet Mask= 255.255.255.0
  RIP Direction= Both
    Version= RIP-2B
  Multicast= IGMP-v2
  IP Policies=
  Edit IP Alias= No

```

Follow the instructions in the next table to configure these fields.

Table 114 Menu 3.2: TCP/IP and DHCP Ethernet Setup

FIELD	DESCRIPTION
DHCP Setup	
DHCP	<p>This field enables/disables the DHCP server.</p> <p>If set to Server, your P-793H v2 will act as a DHCP server. You should configure the rest of the fields in this section except for Remote DHCP Server.</p> <p>If set to Relay, the P-793H v2 acts as a surrogate DHCP server and relays requests and responses between the remote server and the clients. The Remote DHCP Server needs to be set.</p> <p>If set to None, the DHCP server will be disabled.</p>
Client IP Pool Starting Address:	This field specifies the first of the contiguous addresses in the IP address pool.
Size of Client IP Pool	This field specifies the size, or count of the IP address pool.

Table 114 Menu 3.2: TCP/IP and DHCP Ethernet Setup (continued)

FIELD	DESCRIPTION
First DNS Server	The P-793H v2 passes a DNS (Domain Name System) server IP address (in the order you specify here) to the DHCP clients.
Secondary DNS Server	Select From ISP if your ISP dynamically assigns DNS server information (and the P-793H v2's WAN IP address). The IP Address field below displays the (read-only) DNS server IP address that the ISP assigns.
Third DNS Server	Select User-Defined if you have the IP address of a DNS server. Enter the DNS server's IP address in the IP Address field below. If you chose User-Defined , but leave the IP address set to 0.0.0.0, User-Defined changes to None after you save your changes. If you set a second choice to User-Defined , and enter the same IP address, the second User-Defined changes to None after you save your changes. Select DNS Relay to have the P-793H v2 act as a DNS proxy. The P-793H v2's LAN IP address displays in the IP Address field below (read-only). The P-793H v2 tells the DHCP clients on the LAN that the P-793H v2 itself is the DNS server. When a computer on the LAN sends a DNS query to the P-793H v2, the P-793H v2 forwards the query to the P-793H v2's system DNS server (configured in menu 1) and relays the response back to the computer. You can only select DNS Relay for one of the three servers; if you select DNS Relay for a second or third DNS server, that choice changes to None after you save your changes. Select None if you do not want to configure DNS servers. If you do not configure a DNS server, you must know the IP address of a machine in order to access it.
DHCP Server Address	If Relay is selected in the DHCP field above, then type the IP address of the actual remote DHCP server here.
TCP/IP Setup:	
IP Address	Enter the LAN IP address of your P-793H v2 in dotted decimal notation
IP Subnet Mask	Your P-793H v2 will automatically calculate the subnet mask based on the IP address that you assign. Unless you are implementing subnetting, use the subnet mask computed by the P-793H v2.
RIP Direction	Press [SPACE BAR] and then [ENTER] to select the RIP direction. Options are: Both , In Only , Out Only or None .
Version	Press [SPACE BAR] and then [ENTER] to select the RIP version. Options are: RIP-1 , RIP-2B or RIP-2M .
Multicast	IGMP (Internet Group Multicast Protocol) is a session-layer protocol used to establish membership in a Multicast group. The P-793H v2 supports both IGMP version 1 (IGMP-v1) and version 2 (IGMP-v2). Press [SPACE BAR] and then [ENTER] to enable IP Multicasting or select None (default) to disable it.
Edit IP Alias	The P-793H v2 supports three logical LAN interfaces via its single physical Ethernet interface with the P-793H v2 itself as the gateway for each LAN network. Press [SPACE BAR] to select Yes and then press [ENTER] to display menu 3.2.1.
When you have completed this menu, press [ENTER] at the prompt [Press ENTER to Confirm...] to save your configuration, or press [ESC] at any time to cancel.	

26.4 LAN IP Alias

Use menu 3.2 to configure the first network, and you use menu 3.2.1 to configure the other two networks. Move the cursor to the **Edit IP Alias** field, press [SPACE BAR] to choose **Yes** and press [ENTER] to configure the second and third network.

Figure 147 Menu 3.2.1: IP Alias Setup

```

Menu 3.2.1 - IP Alias Setup

IP Alias 1= No
IP Address= N/A
IP Subnet Mask= N/A
RIP Direction= N/A
Version= N/A
Incoming protocol filters= N/A
Outgoing protocol filters= N/A
IP Alias 2= No
IP Address= N/A
IP Subnet Mask= N/A
RIP Direction= N/A
Version= N/A
Incoming protocol filters= N/A
Outgoing protocol filters= N/A

```

Use the instructions in the following table to configure IP alias parameters.

Table 115 Menu 3.2.1: IP Alias Setup

FIELD	DESCRIPTION
IP Alias 1, 2	Choose Yes to configure the LAN network for the P-793H v2.
IP Address	Enter the IP address of your P-793H v2 in dotted decimal notation.
IP Subnet Mask	Your P-793H v2 will automatically calculate the subnet mask based on the IP address that you assign. Unless you are implementing subnetting, use the subnet mask computed by the P-793H v2.
RIP Direction	Press [SPACE BAR] and then [ENTER] to select the RIP direction. Options are Both, In Only, Out Only or None .
Version	Press [SPACE BAR] and then [ENTER] to select the RIP version. Options are RIP-1, RIP-2B or RIP-2M .
Incoming protocol filters	Enter the filter set(s) you wish to apply to the incoming traffic between this node and the P-793H v2.
Outgoing protocol filters	Enter the filter set(s) you wish to apply to the outgoing traffic between this node and the P-793H v2.
When you have completed this menu, press [ENTER] at the prompt [Press ENTER to Confirm...] to save your configuration, or press [ESC] at any time to cancel.	

Internet Access Setup

Use this menu to configure your Internet connection. Use information from your ISP along with the instructions in this chapter to set up your P-793H v2 to access the Internet. Contact your ISP to determine what encapsulation type you should use.

27.1 Internet Access Setup

Enter 4 in the main menu.

Figure 148 Menu 4: Internet Access Setup

```

Menu 4 - Internet Access Setup

ISP's Name= MyISP
Encapsulation= ENET ENCAP
Multiplexing= LLC-based
VPI #= 0
VCI #= 33
ATM QoS Type= UBR
  Peak Cell Rate (PCR)= 0
  Sustain Cell Rate (SCR)= 0
  Maximum Burst Size (MBS)= 0
My Login= N/A
My Password= N/A
ENET ENCAP Gateway= 0.0.0.0
IP Address Assignment= Static
  IP Address= 0.0.0.0
Network Address Translation= SUA Only
Address Mapping Set= N/A

```

The following table describes the fields in this menu.

Table 116 Menu 4: Internet Access Setup

FIELD	DESCRIPTION
ISP's Name	Enter a descriptive name for your ISP for identification purposes.
Encapsulation	Press [SPACE BAR] and then press [ENTER] to select the type of encapsulation your ISP uses.

Table 116 Menu 4: Internet Access Setup (continued)

FIELD	DESCRIPTION
Multiplexing	Press [SPACE BAR] to select the method of multiplexing used by your ISP. Choices are VC-based or LLC-based .
VPI	VPI (Virtual Path Identifier) and VCI (Virtual Channel Identifier) define a virtual circuit. The valid range for the VPI is 0 to 255. Enter the VPI assigned to you.
VCI	The valid range for the VCI is 32 to 65535 (0 to 31 is reserved for local management of ATM traffic). Enter the VCI assigned to you.
ATM QoS Type	Select CBR (Constant Bit Rate) to specify fixed (always-on) bandwidth for voice or data traffic. Select UBR (Unspecified Bit Rate) for applications that are non-time sensitive, such as e-mail. Select VBR (Variable Bit Rate) for bursty traffic and bandwidth sharing with other applications.
Peak Cell Rate (PCR)	Divide the DSL line rate (bps) by 424 (the size of an ATM cell) to find the Peak Cell Rate (PCR). This is the maximum rate at which the sender can send cells. Type the PCR here.
Sustain Cell Rate (SCR)	The Sustain Cell Rate (SCR) sets the average cell rate (long-term) that can be transmitted. Type the SCR, which must be less than the PCR. Note that system default is 0 cells/sec.
Maximum Burst Size (MBS)	Maximum Burst Size (MBS) refers to the maximum number of cells that can be sent at the peak rate. Type the MBS, which is less than 65535.
My Login	(PPPoE and PPPoA only) Enter the login name given to you by your ISP.
My Password	(PPPoE and PPPoA only) Type your password again for confirmation.
ENET ENCAP Gateway	(ENET ENCAP only) Enter the gateway IP address provided by your ISP.
Idle Timeout (sec)	(PPPoE and PPPoA only) Specify an idle time-out. The default setting is 0, which means the Internet session will not timeout.
IP Address Assignment	If your ISP did not assign you a fixed IP address, press [SPACE BAR] and then [ENTER] to select Dynamic , otherwise select Static and enter the IP address and subnet mask in the following fields.
IP Address	This field is enabled if the IP Address Assignment is Static . Enter the (fixed) IP address assigned to you by your ISP (static IP address assignment is selected in the previous field).

Table 116 Menu 4: Internet Access Setup (continued)

FIELD	DESCRIPTION
Network Address Translation	<p>Network Address Translation (NAT) allows the translation of an Internet protocol address used within one network (for example a private IP address used in a local network) to a different IP address known within another network (for example a public IP address used on the Internet).</p> <p>Choose None to disable NAT.</p> <p>Choose SUA Only if you have a single public IP address. SUA (Single User Account) is a subset of NAT that supports two types of mapping: Many-to-One and Server.</p> <p>Choose Full Feature if you have multiple public IP addresses. Full Feature mapping types include: One-to-One, Many-to-One (SUA/PAT), Many-to-Many Overload, Many- One-to-One and Server. When you select Full Feature you must configure at least one address mapping set.</p> <p>Please see Chapter 8 on page 117 for a more detailed discussion on the Network Address Translation feature.</p>
Address Mapping Set	<p>This field is enabled if the Network Address Translation is Full Feature.</p> <p>Enter the number of the address mapping set you want to use for your Internet connection.</p>
<p>When you have completed this menu, press [ENTER] at the prompt "Press ENTER to Confirm..." to save your configuration, or press [ESC] at any time to cancel.</p>	

Remote Node Setup

Use this menu to configure detailed remote node settings (for example, your ISP is a remote node) as well as apply filters.

28.1 Introduction to Remote Node Setup

A remote node is required for placing calls to a remote gateway. A remote node represents both the remote gateway and the network behind it across a WAN connection. Note that when you use menu 4 to set up Internet access, you are actually configuring a remote node.

28.2 Remote Node Setup

From the main menu, select menu option 11 to open **Menu 11 - Remote Node Setup** (shown below).

Figure 149 Menu 11: Remote Node Setup

```
Menu 11 - Remote Node Setup

1. MyISP (ISP, SUA)
2. _____
3. _____
4. _____
5. _____
6. _____
7. _____
8. ChangeMe (BACKUP_ISP, SUA)

Enter Node # to Edit:
```

Type the node number you want to configure and press [ENTER].

28.3 Remote Node Profile

The following explains how to configure remote nodes 1-7.

Figure 150 Menu 11.1: Remote Node Profile (nodes 1-7)

```

Menu 11.1 - Remote Node Profile

Rem Node Name= MyISP           Route= IP
Active= Yes                    Bridge= No

Encapsulation= PPPoE          Edit IP/Bridge= No
Multiplexing= LLC-based       Edit ATM Options= No
Service Name=                 Edit Advance Options= No
Incoming:                     Telco Option:
  Rem Login=                   Allocated Budget(min)= 0
  Rem Password= *****       Period(hr)= 0
Outgoing:                      Schedule Sets=
  My Login=                    Nailed-Up Connection= No
  My Password= *****         Session Options:
  Authen= CHAP/PAP             Edit Filter Sets= No
Line=1                          Idle Timeout(sec)= 0

```

The following table describes the labels in this menu.

Table 117 Menu 11.1: Remote Node Profile (nodes 1-7)

FIELD	DESCRIPTION
Rem Node Name	Enter the name of the ISP.
Active	Select whether or not you want to use this Internet connection.
Encapsulation	Select the type of encapsulation your ISP uses.
Multiplexing	Select the method of multiplexing used by your ISP from the drop-down list. Choices are VC or LLC .
Service Name	(PPPoE only) Enter the service name provided by your ISP. Leave this field blank if your ISP did not provide one.
Incoming	This section is only enabled for PPPoA or PPPoE connections.
Rem Login	Type the login name that this remote node will use to call your P-793H v2. The login name and the Rem Password will be used to authenticate this node.
Rem Password	Type the password used when this remote node calls your P-793H v2.
Outgoing	This section is only enabled for PPPoA or PPPoE connections.
My Login	Enter the user name provided by your ISP.
My Password	Enter the password provided by your ISP.
Retype to Confirm	Enter the password again.
Authen	This field appears if you select PPPoE in the Encapsulation field. Select what type of authentication your ISP uses. Select CHAP/PAP if you want the P-793H v2 to support both choices.

Table 117 Menu 11.1: Remote Node Profile (nodes 1-7) (continued)

FIELD	DESCRIPTION
Line	Select the DSL connection you want the ZyXEL Device to use for outgoing traffic.
Route	<p>Press [SPACE BAR] and then [ENTER] to select IP to enable IP-based routing to this remote node. This is not effective unless you enable IP-based routing in the P-793H v2 too. See Menu 1: General Setup in Section 24.1 on page 307.</p> <p>You should enable Route IP, Bridge, or both in this screen. If you disable Route IP and Bridge, the device does not send traffic between the LAN ports and remote node.</p>
Bridge	<p>If Route is IP, select Yes in this field to enable bridging to this remote node for protocols that are not supported by IP-based routing (for example, SNA).</p> <p>If Route is None, select Yes in this field to enable bridging to this remote node for all protocols.</p> <p>In either case, this setting is not effective unless you enable bridging in the P-793H v2 too. See Menu 1: General Setup in Section 24.1 on page 307.</p> <p>You should enable Route IP, Bridge, or both in this screen. If you disable Route IP and Bridge, the device does not send traffic between the LAN ports and remote node.</p>
Edit IP/Bridge	This field is enabled if Route is IP . If you want to set up the WAN IP address and advanced features for the WAN port, press [SPACE BAR] to select Yes and press [ENTER]. Menu 11.3 appears.
Edit ATM Options	This field is enabled if Route is IP . Press [SPACE BAR] to select Yes and press [ENTER] to edit the virtual channel and ATM QoS settings. Menu 11.6 appears.
Edit Advance Options	This field is displayed if you are editing remote node 1, and it is only enabled for PPPoE connections. If you want to set up advanced features for the Internet connection, press [SPACE BAR] to select Yes and press [ENTER]. Menu 11.8 appears.
Telco Option	This section is only enabled for PPPoA or PPPoE connections.
Allocated Budget(min)	Enter the maximum amount of time (in minutes) each call can last. Enter 0 if there is no limit. With Period , you can set a limit on the total outgoing call time of the P-793H v2 within a certain period of time. When the total outgoing call time exceeds the limit, the current call will be dropped and any future outgoing calls will be blocked.
Period(hr)	Enter how often (in hours) the Allocated Budget is reset. For example, if you can call for thirty minutes every hour, set the Allocated Budget to 30, and set this field to 1.
Schedule Sets	Enter the schedule sets that apply to this connection.
Nailed-Up Connection	Select this if you want the P-793H v2 to automatically connect to your ISP when it is turned on and to remain connected all the time. This is not recommended if you pay for your Internet connected based on the amount of time you are connected.
Session Options	

Table 117 Menu 11.1: Remote Node Profile (nodes 1-7) (continued)

FIELD	DESCRIPTION
Edit Filter Sets	If you want to specify input and output filter sets for the WAN port, press [SPACE BAR] to select Yes and press [ENTER]. Menu 11.5 appears.
Idle Timeout(sec)	Enter the number of seconds the P-793H v2 should wait while there is no Internet traffic before it automatically disconnects from the ISP. Enter a time interval between 10 and 9999 seconds.

28.4 Remote Node Network Layer Options

Move the cursor to the **Edit IP/Bridge** field in menu 11.1, then press [SPACE BAR] to select **Yes**. Press [ENTER] to open **Menu 11.3 - Remote Node Network Layer Options**.

Figure 151 Menu 11.3: Remote Node Network Layer Options

Menu 11.3 - Remote Node Network Layer Options	
IP Options:	Bridge Options:
IP Address Assignment = Static	Ethernet Addr Timeout(min)= N/A
Rem IP Addr = 0.0.0.0	
Rem Subnet Mask= 0.0.0.0	
My WAN Addr= 0.0.0.0	
NAT= SUA Only	
Address Mapping Set= N/A	
Metric= 2	
Private= No	
RIP Direction= Both	
Version= RIP-2B	
Multicast= None	
IP Policies=	

The following table describes the fields in this menu.

Table 118 Menu 11.3: Remote Node Network Layer Options

FIELD	DESCRIPTION
IP Address Assignment	Select Dynamic if your ISP did not give you a fixed (static) IP address. Select Static if your ISP gave you a fixed (static) IP address. The next three fields are not available if you select Dynamic .
Rem IP Addr	Enter the IP address of the remote (peer) computer to which the P-793H v2 connects.
Rem Subnet Mask	Enter the subnet mask of the remote (peer) computer to which the P-793H v2 connects.
My WAN Addr	Enter the fixed (static) IP address provided by your ISP.

Table 118 Menu 11.3: Remote Node Network Layer Options (continued)

FIELD	DESCRIPTION
NAT	<p>Select None if you do not want to use port forwarding, trigger ports, or NAT.</p> <p>Select SUA Only if you want to use one or more of these features and have only one WAN IP address for your P-793H v2.</p> <p>Select Full Feature if you want to use one or more of these features and have more than one public WAN IP address for your P-793H v2.</p>
Address Mapping Set	This field is enabled if NAT is Full Feature . Specify which address mapping set you want to use for this remote node.
Metric	<p>This field sets this route's priority among the routes the P-793H v2 uses.</p> <p>The metric represents the "cost of transmission". A router determines the best route for transmission by choosing a path with the lowest "cost". RIP routing uses hop count as the measurement of cost, with a minimum of "1" for directly connected networks. The number must be between "1" and "15"; a number greater than "15" means the link is down. The smaller the number, the lower the "cost".</p>
Private	This field is related to RIP. This field determines whether or not the P-793H v2 includes the route to this remote node in its RIP broadcasts. If you select Yes , this route is not included in RIP broadcast. If you select No , the route to this remote node is propagated to other hosts through RIP broadcasts. Usually, you should keep the default value.
RIP Direction	<p>Use this field to control how much routing information the P-793H v2 sends and receives through this connection.</p> <p>None - The P-793H v2 does not send or receive routing information through this connection.</p> <p>Both - The P-793H v2 sends and receives routing information through this connection.</p> <p>In Only - The P-793H v2 only receives routing information through this connection.</p> <p>Out Only - The P-793H v2 only sends routing information through this connection.</p>
Version	<p>Select which version of RIP the P-793H v2 uses when it sends or receives information on the subnet.</p> <p>RIP-1 - The P-793H v2 uses RIPv1 to exchange routing information.</p> <p>RIP-2B - The P-793H v2 broadcasts RIPv2 to exchange routing information.</p> <p>RIP-2M - The P-793H v2 multicasts RIPv2 to exchange routing information.</p>

Table 118 Menu 11.3: Remote Node Network Layer Options (continued)

FIELD	DESCRIPTION
Multicast	<p>You do not have to enable multicasting to use RIP-2M. (See RIP Version.)</p> <p>Select which version of IGMP the P-793H v2 uses to support multicasting on this port. Multicasting only sends packets to some computers and is an alternative to unicasting (sending packets to one computer) and broadcasting (sending packets to every computer).</p> <p>None - The P-793H v2 does not support multicasting.</p> <p>IGMP-v1 - The P-793H v2 supports IGMP version 1.</p> <p>IGMP-v2 - The P-793H v2 supports IGMP version 2.</p> <p>Multicasting can improve overall network performance. However, it requires extra processing and generates more network traffic. In addition, other computers have to support the same version of IGMP.</p>
IP Policies	<p>You can apply up to four policy routes for this remote node. Configure the policy routes in menu 25 first. See Chapter 37 on page 411 for information about policy routes.</p>
Bridge Options	
Ethernet Addr Timeout(min)	<p>This field is enabled if Bridge is Yes in SMT Menu 11.1: Remote Node Profile (nodes 1-7). Type the time (in minutes) for the P-793H v2 to retain the Ethernet address information in its internal tables while the line is down. If this information is retained, your P-793H v2 will not have to recompile the tables when the line comes back up.</p>
<p>Once you have completed filling in this menu, press [ENTER] at the message "Press ENTER to Confirm..." to save your configuration and return to menu 11.1, or press [ESC] at any time to cancel.</p>	

28.5 Remote Node Filter

Move the cursor to the field **Edit Filter Sets** in menu 11.1, and then press [SPACE BAR] to set the value to **Yes**. Press [ENTER] to open **Menu 11.1.5 - Remote Node Filter**.

Use this menu to specify the filter set(s) to apply to the incoming and outgoing traffic between this remote node and the P-793H v2 to prevent certain packets from triggering calls. You can specify up to 4 filter sets separated by commas, for example, 1, 5, 9, 12, in each filter field. Note that spaces are accepted in this field. For more information on defining the filters, please refer to [Chapter 32 on](#)

[page 357](#). For PPPoE or PPTP encapsulation, you have the additional option of specifying remote node call filter sets.

Figure 152 Menu 11.5: Remote Node Filter

```

Menu 11.5 - Remote Node Filter

Input Filter Sets:
  protocol filters=
  device filters=
Output Filter Sets:
  protocol filters=
  device filters=

```

The following table describes the labels in this menu.

Table 119 Menu 11.5: Remote Node Filter

FIELD	DESCRIPTION
Input Filter Sets	
protocol filters	Enter up to four filter sets. If you enter more than one, separate each one with a comma (,).
device filters	Enter up to four filter sets. If you enter more than one, separate each one with a comma (,).
Output Filter Sets	
protocol filters	Enter up to four filter sets. If you enter more than one, separate each one with a comma (,).
device filters	Enter up to four filter sets. If you enter more than one, separate each one with a comma (,).

28.6 Remote Node ATM Layer Options

Move the cursor to the **Edit ATM Options** field in menu 11.1, then press [SPACE BAR] to select **Yes**. Press [ENTER] to open this menu. This menu depends on the multiplexing and encapsulation you select in menu 11.1.

Figure 153 Menu 11.6: Remote Node ATM Layer Options

Menu 11.6 - Remote Node ATM Layer Options VPI/VCI (LLC-Multiplexing or PPP-Encapsulation)	
VPI #=	0
VCI #=	38
ATM QoS Type=	UBR
Peak Cell Rate (PCR)=	0
Sustain Cell Rate (SCR)=	0
Maximum Burst Size (MBS)=	0

The following table describes the fields in this menu.

Table 120 Menu 11.6: Remote Node ATM Layer Options

FIELD	DESCRIPTION
VPI	The valid range for the VPI is 0 to 255. Enter the VPI assigned to you.
VCI	The valid range for the VCI is 32 to 65535 (0 to 31 is reserved for local management of ATM traffic). Enter the VCI assigned to you.
ATM QoS Type	Select CBR (Constant Bit Rate) to specify fixed (always-on) bandwidth for voice or data traffic. Select UBR (Unspecified Bit Rate) for applications that are non-time sensitive, such as e-mail. Select VBR (Variable Bit Rate) for bursty traffic and bandwidth sharing with other applications.
Peak Cell Rate (PCR)	Divide the DSL line rate (bps) by 424 (the size of an ATM cell) to find the Peak Cell Rate (PCR). This is the maximum rate at which the sender can send cells. Type the PCR here.
Sustain Cell Rate (SCR)	The Sustain Cell Rate (SCR) sets the average cell rate (long-term) that can be transmitted. Type the SCR, which must be less than the PCR. Note that system default is 0 cells/sec.
Maximum Burst Size (MBS)	Maximum Burst Size (MBS) refers to the maximum number of cells that can be sent at the peak rate. Type the MBS, which is less than 65535.
Once you have completed filling in this menu, press [ENTER] at the message "Press ENTER to Confirm..." to save your configuration and return to menu 11.1, or press [ESC] at any time to cancel.	

28.7 Advance Setup Options

You can edit advanced setup options when the encapsulation is **PPPoE**. Move the cursor to the **Edit Advance Options** field in menu 11.1 (only for remote node 1), then press [SPACE BAR] to select **Yes**. Press [ENTER] to open **Menu 11.8 - Advanced Setup Options**.

Figure 154 Menu 11.8: Advance Setup Options

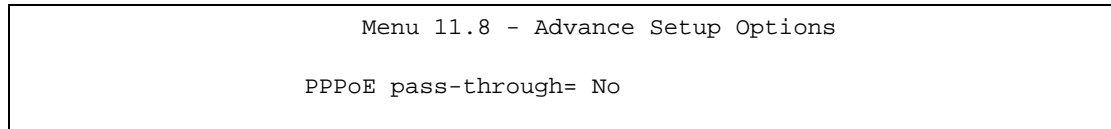

The following table describes the fields in this menu.

Table 121 Menu 11.8: Advance Setup Options

FIELD	DESCRIPTION
PPPoE pass-through	<p>In addition to the ZyXEL Device's built-in PPPoE client, you can enable PPPoE Passthrough to allow up to ten hosts on the LAN to use PPPoE client software on their computers to connect to the ISP via the ZyXEL Device. Each host can have a separate account and a public WAN IP address.</p> <p>PPPoE pass through is an alternative to NAT for applications where NAT is not appropriate.</p> <p>Disable PPPoE passthrough if you do not need to allow hosts on the LAN to use PPPoE client software on their computers to connect to the ISP.</p>
<p>Once you have completed filling in this menu, press [ENTER] at the message "Press ENTER to Confirm..." to save your configuration and return to menu 11.1, or press [ESC] at any time to cancel.</p>	

Static Route Setup

Use this menu to configure IP and bridge (MAC) static routes.

29.1 IP Static Route Setup

Enter 1 from the menu 12. Select one of the IP static routes as shown next to configure IP static routes in menu 12.1.

Figure 155 Menu 12.1: IP Static Route Setup

```
Menu 12.1 - IP Static Route Setup

1. _____
2. _____
3. _____
4. _____
5. _____
6. _____
7. _____
8. _____
9. _____
10. _____
11. _____
12. _____
13. _____
14. _____
15. _____
16. _____
```

Now, enter the index number of the static route that you want to configure.

Figure 156 Menu 12.1.1: Edit IP Static Route

```

Menu 12.1.1 - Edit IP Static Route

Route #: 1
Route Name= ?
Active= No
Destination IP Address= ?
IP Subnet Mask= ?
Gateway IP Address= ?
Metric= 2
Private= No

```

The following table describes the fields in this screen.

Table 122 Menu 12.1.1: Edit IP Static Route

FIELD	DESCRIPTION
Route #	This is the index number of the static route that you chose in menu 12.
Route Name	Enter a descriptive name for this route. This is for identification purposes only.
Active	This field allows you to activate/deactivate this static route.
Destination IP Address	This parameter specifies the IP network address of the final destination. Routing is always based on network number. If you need to specify a route to a single host, use a subnet mask of 255.255.255.255 in the subnet mask field to force the network number to be identical to the host ID.
IP Subnet Mask	Enter the IP subnet mask for this destination.
Gateway IP Address	Enter the IP address of the gateway. The gateway is an immediate neighbor of your P-793H v2 that will forward the packet to the destination. On the LAN, the gateway must be a router on the same segment as your P-793H v2; over the WAN, the gateway must be the IP address of one of the remote nodes.
Metric	Enter a number from 1 to 15 to set this route's priority among the P-793H v2's routes (see Section 6.6 on page 96). The smaller the number, the higher priority the route has.
Private	This parameter determines if the P-793H v2 will include the route to this remote node in its RIP broadcasts. If set to Yes , this route is kept private and not included in RIP broadcast. If No , the route to this remote node will be propagated to other hosts through RIP broadcasts.
Once you have completed filling in this menu, press [ENTER] at the message "Press ENTER to Confirm..." to save your configuration, or press [ESC] to cancel.	

29.2 Bridge Static Route Setup

Enter 3 from menu 12. Select one of the bridge static routes as shown next to configure IP static routes in menu 12.3.

Figure 157 Menu 12.3: Bridge Static Route Setup

```

Menu 12.3 - Bridge Static Route Setup

1. _____
2. _____
3. _____
4. _____

```

Now, enter the index number of the static route that you want to configure.

Figure 158 Menu 12.3.1: Edit Bridge Static Route

```

Menu 12.3.1 - Edit Bridge Static Route

Route #: 1
Route Name= ?
Active= No
Ether Address= ?
IP Address=
Gateway Node= 1

```

The following table describes the fields in this screen.

Table 123 Menu 12.3.1: Edit Bridge Static Route

FIELD	DESCRIPTION
Route #	This is the index number of the static route that you chose in menu 12.
Route Name	Enter a descriptive name for this route. This is for identification purposes only.
Active	This field allows you to activate/deactivate this static route.
Ether Address	This parameter specifies the MAC address of the final destination.
IP Address	Enter the IP address of the gateway. The gateway is an immediate neighbor of your P-793H v2 that will forward the packet to the destination. On the LAN, the gateway must be a router on the same segment as your P-793H v2; over the WAN, the gateway must be the IP address of one of the remote nodes.
Gateway Node	Press [SPACE BAR] and then [ENTER] to select the number of the remote node that is the gateway for this static route.
Once you have completed filling in this menu, press [ENTER] at the message "Press ENTER to Confirm..." to save your configuration, or press [ESC] to cancel.	

NAT Setup

Use this menu to configure Network Address Translation (NAT) on the P-793H v2.

30.1 Using NAT

Note: You must create a firewall rule in addition to setting up SUA/NAT, to allow traffic from the WAN to be forwarded through the P-793H v2.

30.1.1 SUA (Single User Account) Versus NAT

SUA (Single User Account) is a ZyNOS implementation of a subset of NAT that supports two types of mapping, **Many-to-One** and **Server**. See [Section 30.2.1 on page 342](#) for a detailed description of the NAT set for SUA. The P-793H v2 also supports **Full Feature** NAT to map multiple global IP addresses to multiple private LAN IP addresses of clients or servers using mapping types.

Choose **SUA Only** if you have just one public WAN IP address for your P-793H v2.

Note: Choose **Full Feature** if you have multiple public WAN IP addresses for your P-793H v2.

30.1.2 Applying NAT

You apply NAT via menus 4 or 11.3 as displayed next. The next figure shows you how to apply NAT for Internet access in menu 4. Enter 4 from the main menu to go to **Menu 4 - Internet Access Setup**.

Figure 159 Menu 4: Applying NAT for Internet Access

```
Menu 4 - Internet Access Setup

ISP's Name= MyISP
Encapsulation= ENET ENCAP
Multiplexing= LLC-based
VPI #= 0
VCI #= 33
ATM QoS Type= UBR
  Peak Cell Rate (PCR)= 0
  Sustain Cell Rate (SCR)= 0
  Maximum Burst Size (MBS)= 0
My Login= N/A
My Password= N/A
ENET ENCAP Gateway= 0.0.0.0
IP Address Assignment= Static
  IP Address= 0.0.0.0
Network Address Translation= SUA Only
  Address Mapping Set= N/A
```

The following figure shows how you apply NAT to the remote node in menu 11.3.

- 1 Enter 11 from the main menu.
- 2 Enter 1 to open **Menu 11.1 - Remote Node Profile**.

- 3 Move the cursor to the **Edit IP/Bridge** field, press [SPACE BAR] to select **Yes** and then press [ENTER] to bring up **Menu 11.3 - Remote Node Network Layer Options**.

Figure 160 Menu 11.3: Applying NAT to the Remote Node

```

Menu 11.3 - Remote Node Network Layer Options

IP Options:                               Bridge Options:
IP Address Assignment = Static             Ethernet Addr Timeout(min)= N/A
Rem IP Addr = 0.0.0.0
Rem Subnet Mask= 0.0.0.0
My WAN Addr= 0.0.0.0
NAT= SUA Only
Address Mapping Set= N/A
Metric= 2
Private= No
RIP Direction= Both
Version= RIP-2B
Multicast= None
IP Policies=

```

The following table describes the fields in this menu.

Table 124 Applying NAT in Menus 4 & 11.3

FIELD	DESCRIPTION	OPTIONS
Network Address Translation	When you select this option the SMT will use the specified address mapping set (menu 15.1 - see Section 30.2.1 on page 342 for further discussion). You can configure any of the mapping types described in Chapter 8 on page 117 . Choose Full Feature if you have multiple public WAN IP addresses for your P-793H v2.	Full Feature
	When you select Full Feature you must configure at least one address mapping set.	
	NAT is disabled when you select this option.	None
	When you select this option the SMT will use Address Mapping Set 255 (menu 15.1 - see Section 30.2.1 on page 342). Choose SUA Only if you have just one public WAN IP address for your P-793H v2.	SUA Only

30.2 NAT Setup

Use the address mapping sets menus and submenus to create the mapping table used to assign global addresses to computers on the LAN and the DMZ. **Set 255** is used for SUA. When you select **Full Feature** in menu 4 or menu 11.3, the SMT will use the address mapping set that you specify. When you select **SUA Only**, the SMT will use the pre-configured **Set 255** (read only).

A server set is a list of LAN servers mapped to external ports. To use this set, a server rule must be set up inside the NAT address mapping set. Please see the section on port forwarding in [Section 8.3 on page 120](#) for further information on these menus. To configure NAT, enter 15 from the main menu to bring up the following screen.

Figure 161 Menu 15: NAT Setup

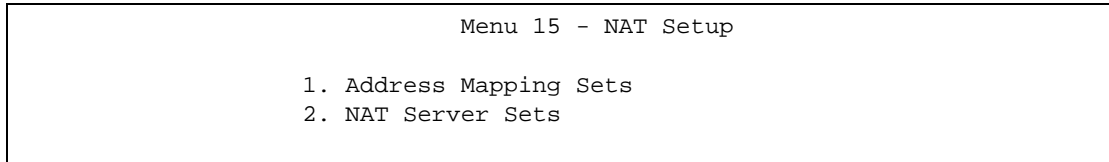

30.2.1 Address Mapping Sets

Enter 1 to bring up **Menu 15.1.1 - Address Mapping Sets**.

Figure 162 Menu 15.1: Address Mapping Sets

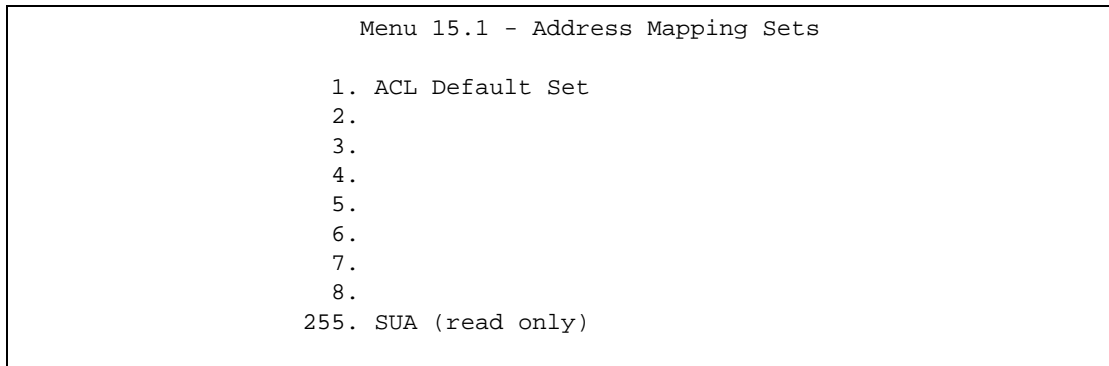

Select the address mapping set you want to modify. The fields in address 255 are used for SUA and are read-only.

30.2.1.1 User-Defined Address Mapping Sets

Note: The entire set will be deleted if you leave the **Set Name** field blank and press [ENTER] at the bottom of the screen.

Figure 163 Menu 15.1.1: Address Mapping Rules

```

Menu 15.1.1 - Address Mapping Rules

Set Name= ACL Default Set

Idx  Local Start IP  Local End IP  Global Start IP  Global End IP  Type
-----
1.
2.
3.
4.
5.
6.
7.
8.
9.
10.

Action= None          Select Rule= N/A

```

Note: The Type, Local and Global Start/End IPs are configured in menu 15.1.1.1 (described later) and the values are displayed here.

Table 125 Menu 15.1.1: Address Mapping Rules

FIELD	DESCRIPTION
Set Name	This is the name of the set you selected in menu 15.1 or enter the name of a new set you want to create.
Idx	This is the index or rule number.
Local Start IP	Local Start IP is the starting local IP address (ILA).
Local End IP	Local End IP is the ending local IP address (ILA). If the rule is for all local IPs, then the start IP is 0.0.0.0 and the end IP is 255.255.255.255.
Global Start IP	This is the starting global IP address (IGA). If you have a dynamic IP, enter 0.0.0.0 as the Global Start IP .
Global End IP	This is the ending global IP address (IGA).
Type	These are the mapping types discussed above. Server allows us to specify multiple servers of different types behind NAT to this machine. See later for some examples.
Once you have finished configuring a rule in this menu, press [ENTER] at the message "Press ENTER to Confirm..." to save your configuration, or press [ESC] to cancel.	

Ordering your rules is important because the P-793H v2 applies the rules in the order that you specify. When a rule matches the current packet, the P-793H v2 takes the corresponding action and the remaining rules are ignored. If there are any empty rules before your new configured rule, your configured rule will be pushed up by that number of empty rules. For example, if you have already configured rules 1 to 6 in your current set and now you configure rule number 9. In the set summary screen, the new rule will be rule 7, not 9.

Now if you delete rule 4, rules 5 to 7 will be pushed up by 1 rule, so as old rule 5 becomes rule 4, old rule 6 becomes rule 5 and old rule 7 becomes rule 6.

Note: You must press [ENTER] at the bottom of the screen to save the whole set. You must do this again if you make any changes to the set – including deleting a rule. No changes to the set take place until this action is taken.

Selecting **Edit** in the **Action** field and then selecting a rule brings up the following menu, **Menu 15.1.1.1 - Address Mapping Rule** in which you can edit an individual rule and configure the **Type**, **Local** and **Global Start/End IPs**.

Note: An IP End address must be numerically greater than its corresponding IP Start address.

Figure 164 Menu 15.1.1.1: Address Mapping Rule

```

Menu 15.1.1.1 Address Mapping Rule

Type= Server

Local IP:
  Start= N/A
  End  = N/A

Global IP:
  Start= 0.0.0.0
  End  = N/A

Server Mapping Set= 2

```

The following table describes the fields in this menu.

Table 126 Menu 15.1.1.1: Address Mapping Rule

FIELD	DESCRIPTION
Type	Press [SPACE BAR] and then [ENTER] to select from a total of five types. These are the mapping types discussed in Chapter 8 on page 117 . Server allows you to specify multiple servers of different types behind NAT to this computer. See Section 30.4.3 on page 348 for an example.
Local IP	These fields are enabled depending on the Type .
Start	Enter the starting local IP address (ILA).

Table 126 Menu 15.1.1.1: Address Mapping Rule (continued)

FIELD	DESCRIPTION
End	Enter the ending local IP address (ILA). If the rule is for all local IPs, then put the Start IP as 0.0.0.0 and the End IP as 255.255.255.255. This field is N/A for One-to-One and Server types.
Global IP	These fields are enabled depending on the Type .
Start	Enter the starting global IP address (IGA). If you have a dynamic IP, enter 0.0.0.0 as the Global IP Start . Note that Global IP Start can be set to 0.0.0.0 only if the types are Many-to-One or Server .
End	Enter the ending global IP address (IGA). This field is N/A for One-to-One , Many-to-One and Server types.
Server Mapping Set	This field is available only when you select Server in the Type field. Select which server mapping set to use for this rule.
Once you have finished configuring a rule in this menu, press [ENTER] at the message "Press ENTER to Confirm..." to save your configuration, or press [ESC] to cancel.	

30.3 Configuring a Server behind NAT

Note: If you do not assign a **Default Server** IP address, the P-793H v2 discards all packets received for ports that are not specified here or in the remote management setup.

Follow these steps to configure a server behind NAT:

- 1 Enter 15 in the main menu to go to **Menu 15 - NAT Setup**.
- 2 Enter 2 to open menu 15.2 (and configure the address mapping rules for the WAN port on a P-793H v2 with a single WAN port).

Figure 165 Menu 15.2: NAT Server Sets

Menu 15.2 - NAT Server Sets	
1.	Server Set 1 (Used for SUA Only)
2.	Server Set 2
3.	Server Set 3
4.	Server Set 4
5.	Server Set 5
6.	Server Set 6
7.	Server Set 7
8.	Server Set 8
9.	Server Set 9
10.	Server Set 10

- 3 Enter 1 to configure the server set used by SUA, or enter the number of the server set you want to modify for full-feature NAT. In **Menu 15.2 - NAT Server Setup**, configure the port forwarding rules.

Figure 166 Menu 15.2: NAT Server Setup

Menu 15.2 - NAT Server Setup			
Rule	Start Port No.	End Port No.	IP Address
1.	Default	Default	0.0.0.0
2.	80	80	192.168.1.10
3.	0	0	0.0.0.0
4.	0	0	0.0.0.0
5.	0	0	0.0.0.0
6.	0	0	0.0.0.0
7.	0	0	0.0.0.0
8.	0	0	0.0.0.0
9.	0	0	0.0.0.0
10.	0	0	0.0.0.0
11.	0	0	0.0.0.0
12.	0	0	0.0.0.0

The first entry is for the **Default Server**. The following table describes the labels in this menu.

Table 127 Menu 15.2: NAT Server Setup

FIELD	DESCRIPTION
Rule	This field is a sequential value, and it is not associated with a specific rule. The sequence is important, however. The P-793H v2 checks each active rule in order, and it only follows the first one that applies.
Start Port	This field displays the beginning of the range of port numbers forwarded by this rule.
End Port	This field displays the end of the range of port numbers forwarded by this rule. If it is the same as the Start Port , only one port number is forwarded.
IP Address	This field displays the IP address of the server to which packet for the selected port(s) are forwarded.

30.4 General NAT Examples

The following are some examples of NAT configuration.

30.4.1 Internet Access Only

In the following Internet access example, you only need one rule where all your ILAs (Inside Local addresses) map to one dynamic IGA (Inside Global Address) assigned by your ISP.

Figure 167 NAT Example 1

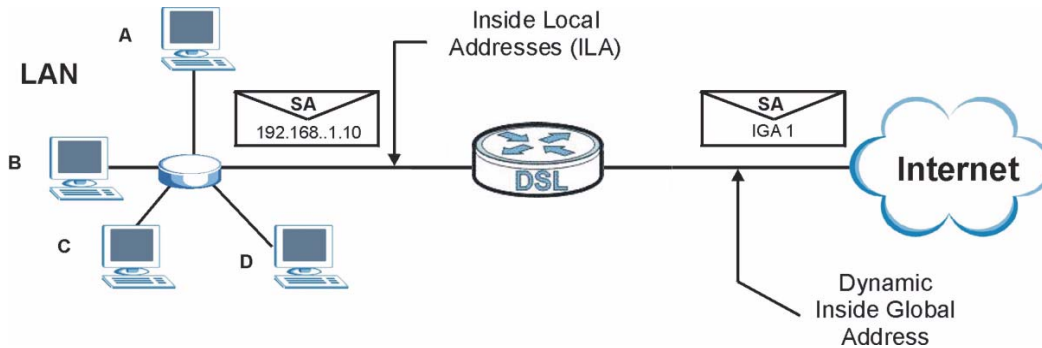

Figure 168 Menu 4: Internet Access & NAT Example

```

Menu 4 - Internet Access Setup

ISP's Name= MyISP
Encapsulation= ENET ENCAP
Multiplexing= LLC-based
VPI #- 0
VCI #- 33
ATM QoS Type= UBR
  Peak Cell Rate (PCR)= 0
  Sustain Cell Rate (SCR)= 0
  Maximum Burst Size (MBS)= 0
My Login= N/A
My Password= N/A
ENET ENCAP Gateway= 0.0.0.0
IP Address Assignment= Static
  IP Address= 0.0.0.0
Network Address Translation= SUA Only
  Address Mapping Set= N/A

```

From menu 4 shown above, simply choose the **SUA Only** option from the **Network Address Translation** field. This is the Many-to-One mapping discussed in [Section 30.4 on page 346](#). The **SUA Only** read-only option from the **Network Address Translation** field in menus 4 and 11.3 is specifically pre-configured to handle this case.

30.4.2 Example 2: Internet Access with a Default Server

Figure 169 NAT Example 2

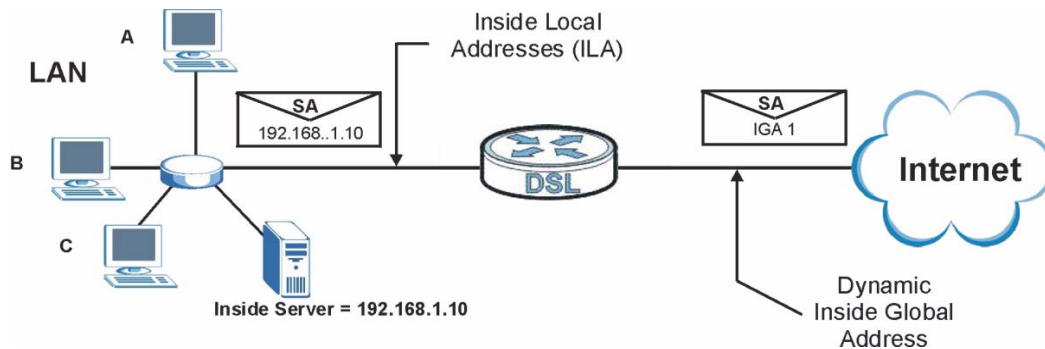

In this case, you do exactly as above (use the convenient pre-configured **SUA Only** set) and also go to menu 15.2.1 to specify the **Default Server** behind the NAT as shown in the next figure.

Figure 170 Menu 15.2: Specifying an Inside Server

Menu 15.2 - NAT Server Setup			
Rule	Start Port No.	End Port No.	IP Address
1.	Default	Default	192.168.1.10
2.	21	25	192.168.1.33
3.	0	0	0.0.0.0
4.	0	0	0.0.0.0
5.	0	0	0.0.0.0
6.	0	0	0.0.0.0
7.	0	0	0.0.0.0
8.	0	0	0.0.0.0
9.	0	0	0.0.0.0
10.	0	0	0.0.0.0
11.	0	0	0.0.0.0
12.	0	0	0.0.0.0

30.4.3 Example 3: Multiple Public IP Addresses With Inside Servers

In this example, there are 3 IGAs from our ISP. There are many departments but two have their own FTP server. All departments share the same router. The example will reserve one IGA for each department with an FTP server and all departments use the other IGA. Map the FTP servers to the first two IGAs and the other LAN traffic to the remaining IGA. Map the third IGA to an inside web server and mail server. Four rules need to be configured, two bi-directional and two uni-directional as follows.

- 1 Map the first IGA to the first inside FTP server for FTP traffic in both directions (1 : 1 mapping, giving both local and global IP addresses).
- 2 Map the second IGA to our second inside FTP server for FTP traffic in both directions (1 : 1 mapping, giving both local and global IP addresses).
- 3 Map the other outgoing LAN traffic to IGA3 (**Many** : 1 mapping).
- 4 You also map your third IGA to the web server and mail server on the LAN. Type **Server** allows you to specify multiple servers, of different types, to other computers behind NAT on the LAN.

The example situation looks somewhat like this:

Figure 171 NAT Example 3

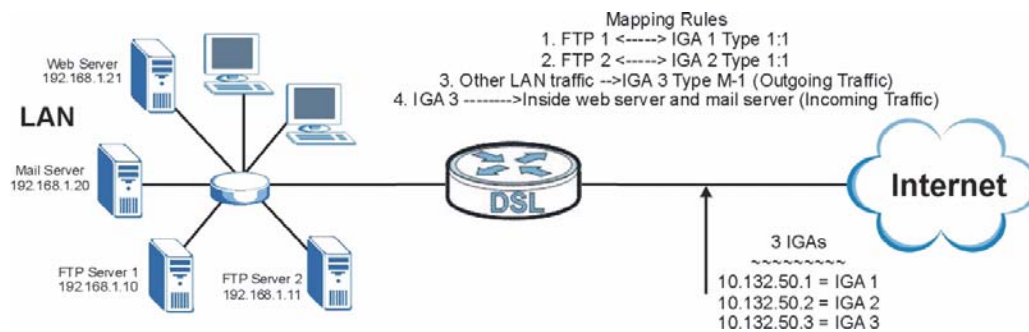

- 1 In this case you need to configure Address Mapping Set 1 from **Menu 15.1 - Address Mapping Sets**. Therefore you must choose the **Full Feature** option from the **Network Address Translation** field (in menu 4 or menu 11.3) in [Figure 172 on page 350](#).
- 2 Then enter 15 from the main menu.
- 3 Enter 1 to configure the Address Mapping Sets.
- 4 Enter 1 to begin configuring this new set. Enter a Set Name, choose the **Edit Action** and then enter 1 for the **Select Rule** field. Press [ENTER] to confirm.
- 5 Select **Type** as **One-to-One** (direct mapping for packets going both ways), and enter the local **Start IP** as 192.168.1.10 (the IP address of FTP Server 1), the global **Start IP** as 10.132.50.1 (our first IGA). (See [Figure 173 on page 351](#)).
- 6 Repeat the previous step for rules 2 to 4 as outlined above.

- 7 When finished, menu 15.1.1 should look like as shown in [Figure 174 on page 351](#).

Figure 172 Example 3: Menu 11.3

```
Menu 11.3 - Remote Node Network Layer Options

IP Options:                               Bridge Options:
IP Address Assignment = Dynamic           Ethernet Addr Timeout(min)= N/A
Rem IP Addr = 0.0.0.0
Rem Subnet Mask= 0.0.0.0
My WAN Addr= N/A
NAT= SUA Only
    Address Mapping Set= N/A
Metric= 2
Private= No
RIP Direction= None
    Version= RIP-1
Multicast= None
IP Policies=
```

The following figure shows how to configure the first rule.

Figure 173 Example 3: Menu 15.1.1.1

```

Menu 15.1.1.1 Address Mapping Rule

Type= One-to-One

Local IP:
  Start= 192.168.1.10
  End  = N/A

Global IP:
  Start= 10.132.50.1
  End  = N/A

Server Mapping Set= N/A

```

Figure 174 Example 3: Final Menu 15.1.1

```

Menu 15.1.1 - Address Mapping Rules

Set Name= Example3

Idx  Local Start IP  Local End IP  Global Start IP  Global End IP  Type
-----
1.   192.168.1.10           10.132.50.1      1-1
2.   192.168.1.11           10.132.50.2      1-1
3.   0.0.0.0             255.255.255.255  10.32.50.3       M-1
4.                                     10.132.50.3      Serve+
5.
6.
7.
8.
9.
10.

Action= None          Select Rule= N/A

```

Now configure the IGA3 to map to our web server and mail server on the LAN.

- 1 Enter 15 from the main menu.
- 2 Enter 2 to go to menu 15.2.

- 3 (Enter 1 or 2 from menu 15.2 on a P-793H v2 with multiple WAN ports) configure the menu as shown in [Figure 175 on page 352](#).

Figure 175 Example 3: Menu 15.2

Menu 15.2 - NAT Server Setup			
Rule	Start Port No.	End Port No.	IP Address
1.	Default	Default	0.0.0.0
2.	80	80	192.168.1.21
3.	25	25	192.168.1.20
4.	0	0	0.0.0.0
5.	0	0	0.0.0.0
6.	0	0	0.0.0.0
7.	0	0	0.0.0.0
8.	0	0	0.0.0.0
9.	0	0	0.0.0.0
10.	0	0	0.0.0.0
11.	0	0	0.0.0.0
12.	0	0	0.0.0.0

30.4.4 Example 4: NAT Unfriendly Application Programs

Some applications do not support NAT Mapping using TCP or UDP port address translation. In this case it is better to use **Many-One-to-One** mapping as port numbers do *not* change for **Many-One-to-One** (and **One-to-One**) NAT mapping types. The following figure illustrates this.

Figure 176 NAT Example 4

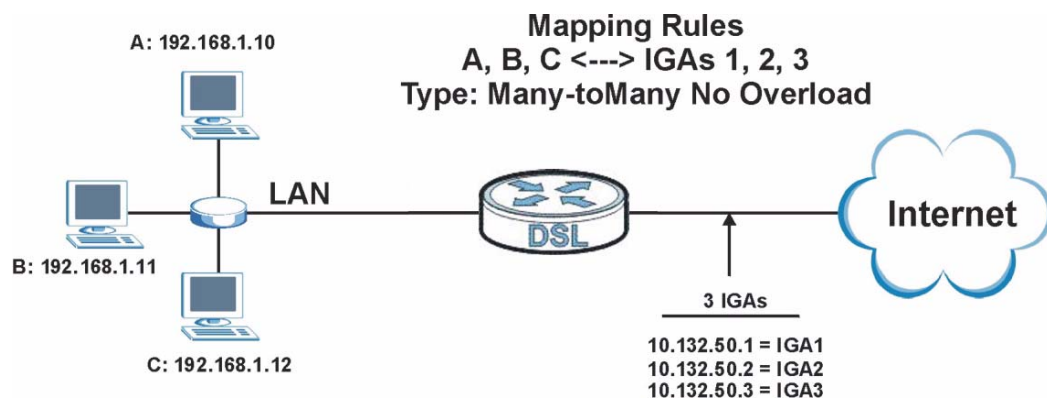

Note: Other applications such as some gaming programs are NAT unfriendly because they embed addressing information in the data stream. These applications won't work through NAT even when using **One-to-One** and **Many-One-to-One** mapping types.

Follow the steps outlined in example 3 above to configure these two menus as follows.

Figure 177 Example 4: Menu 15.1.1.1: Address Mapping Rule

```

Menu 15.1.1.1 Address Mapping Rule

Type= Many-to-Many No Overload

Local IP:
  Start= 192.168.1.10
  End  = 192.168.1.12

Global IP:
  Start= 10.132.50.1
  End  = 10.132.50.3

Server Mapping Set= N/A

```

After you've configured your rule, you should be able to check the settings in menu 15.1.1 as shown next. Example 4: Menu 15.1.1: Address Mapping Rules

```

Menu 15.1.1 - Address Mapping Rules

Set Name= Example4

Idx  Local Start IP   Local End IP   Global Start IP   Global End IP   Type
---  -
1.  192.168.1.10     192.168.1.12   10.132.50.1      10.132.50.3    M-M N+
2.
3.
4.
5.
6.
7.
8.
9.
10.

Action= None          Select Rule= N/A

```

Firewall Setup

Use this menu to activate or deactivate the firewall.

31.1 Using P-793H v2 SMT Menus

From the main menu enter 21 to go to **Menu 21 - Filter and Firewall Setup** to display the screen shown next.

Figure 178 Menu 21: Filter and Firewall Setup

```
Menu 21 - Filter and Firewall Setup

1. Filter Setup
2. Firewall Setup
```

31.1.1 Activating the Firewall

Enter option 2 in this menu to bring up the following screen. Press [SPACE BAR] and then [ENTER] to select **Yes** in the **Active** field to activate the firewall. The firewall must be active to protect against Denial of Service (DoS) attacks. Use the web configurator to configure firewall rules. Use the web configurator or SMT

menu 15 to configure the **LAN-to-WAN Set Name** and **WAN-to-LAN Set Name**.

Figure 179 Menu 21.2: Firewall Setup

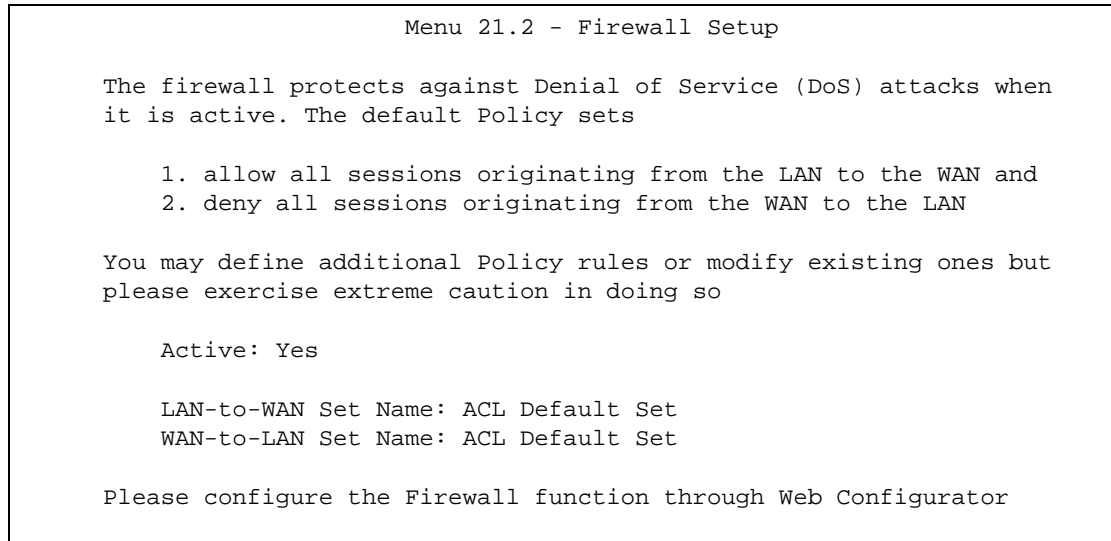

Note: It is recommended to configure the firewall rules using the web configurator.

Filter Configuration

This chapter shows you how to create and apply filters.

32.1 Introduction to Filters

Your P-793H v2 uses filters to decide whether to allow passage of a data packet and/or to make a call. There are two types of filter applications: data filtering and call filtering. Filters are subdivided into device and protocol filters, which are discussed later.

Data filtering screens the data to determine if the packet should be allowed to pass. Data filters are divided into incoming and outgoing filters, depending on the direction of the packet relative to a port. Data filtering can be applied on either the WAN side or the LAN side. Call filtering is used to determine if a packet should be allowed to trigger a call. Remote node call filtering is only applicable when using PPPoE encapsulation. Outgoing packets must undergo data filtering before they encounter call filtering as shown in the following figure.

Figure 180 Outgoing Packet Filtering Process

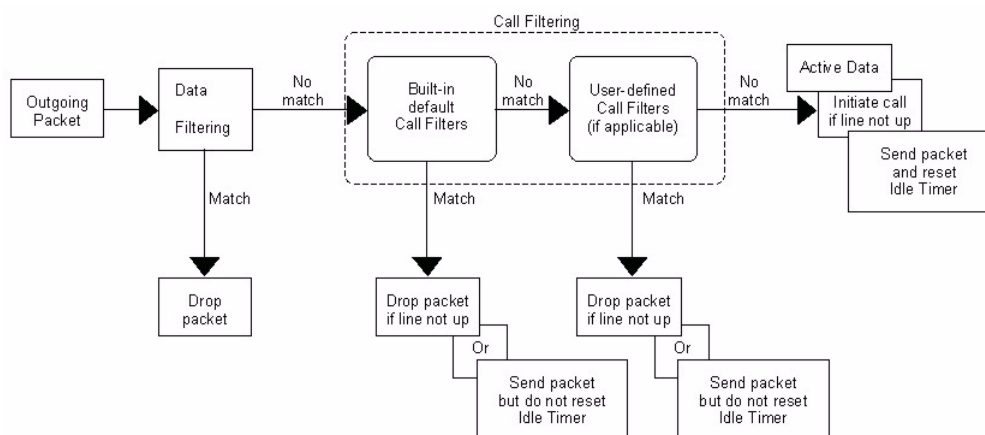

For incoming packets, your P-793H v2 applies data filters only. Packets are processed depending upon whether a match is found. The following sections describe how to configure filter sets.

32.1.1 The Filter Structure of the P-793H v2

A filter set consists of one or more filter rules. Usually, you would group related rules, for example all the rules for NetBIOS, into a single set and give it a descriptive name. The P-793H v2 allows you to configure up to twelve filter sets with six rules in each set, for a total of 72 filter rules in the system. You cannot mix device filter rules and protocol filter rules within the same set. You can apply up to four filter sets to a particular port to block multiple types of packets. With each filter set having up to six rules, you can have a maximum of 24 rules active for a single port.

Sets of factory default filter rules have been configured in menu 21 to prevent NetBIOS traffic from triggering calls and to prevent incoming telnet sessions. A summary of their filter rules is shown in the figures that follow.

The following figure illustrates the logic flow when executing a filter rule. See also [Figure 186 on page 365](#) for the logic flow when executing an IP filter.

Figure 181 Filter Rule Process

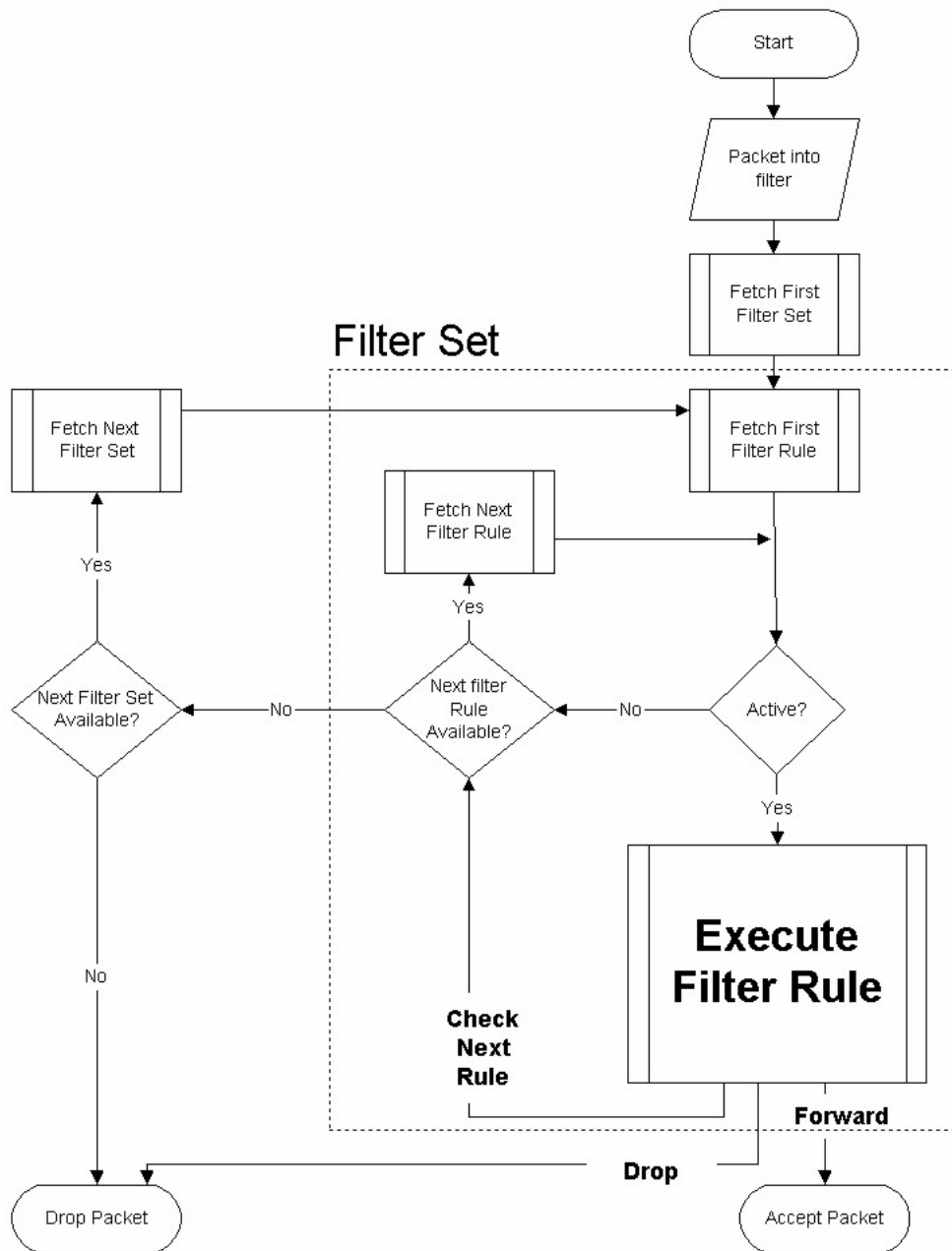

You can apply up to four filter sets to a particular port to block multiple types of packets. With each filter set having up to six rules, you can have a maximum of 24 rules active for a single port.

32.2 Configuring a Filter Set

The P-793H v2 includes filtering for NetBIOS over TCP/IP packets by default. To configure another filter set, follow the procedure below.

- 1 Enter 21 in the main menu to open menu 21.

Figure 182 Menu 21: Filter and Firewall Setup

```

Menu 21 - Filter and Firewall Setup

1. Filter Setup
2. Firewall Setup

```

- 2 Enter 1 to bring up the following menu.

Figure 183 Menu 21.1: Filter Set Configuration

```

Menu 21.1 - Filter Set Configuration

Filter                               Filter
Set #      Comments                    Set #      Comments
-----
1      NetBIOS_WAN                       7      _____
2      NetBIOS_LAN                       8      _____
3      TELNET_WAN                        9      _____
4      PPPoE                             10     _____
5      FTP_WAN                            11     _____
6      _____                          12     _____

Enter Filter Set Number to Configure= 0

Edit Comments= N/A

```

- 3 Select the filter set you wish to configure (1-12) and press [ENTER].
- 4 Enter a descriptive name or comment in the **Edit Comments** field and press [ENTER].
- 5 Press [ENTER] at the message [Press ENTER to confirm] to open **Menu 21.1.1 - Filter Rules Summary**.

This screen shows the summary of the existing rules in the filter set.

Figure 184 Menu 21.1.1: Filter Rules Summary

Menu 21.1.1 - Filter Rules Summary			
#	A	Type	Filter Rules
			M m n
1	N		
2	N		
3	N		
4	N		
5	N		
6	N		

The following table describes the labels in this screen.

Table 128 Abbreviations Used in the Filter Rules Summary Menu

FIELD	DESCRIPTION
#	This is an index number.
A	Active: "Y" means the rule is active. "N" means the rule is inactive.
Type	The type of filter rule: "GEN" for Generic, "IP" for TCP/IP.
Filter Rules	These parameters are displayed here.
M	More. "Y" means there are more rules to check which form a rule chain with the present rule. An action cannot be taken until the rule chain is complete. "N" means there are no more rules to check. You can specify an action to be taken, in other words forward the packet, drop the packet or check the next rule. For the latter, the next rule is independent of the rule just checked.
m	Action Matched. "F" means to forward the packet immediately and skip checking the remaining rules. "D" means to drop the packet. "N" means to check the next rule.
n	Action Not Matched. "F" means to forward the packet immediately and skip checking the remaining rules. "D" means to drop the packet. "N" means to check the next rule.

The following tables contain a brief description of the abbreviations used in the previous menus. The protocol dependent filter rules abbreviation are listed as follows:

Table 129 Rule Abbreviations Used

ABBREVIATION	DESCRIPTION
IP	
Pr	Protocol
SA	Source Address
SP	Source Port number
DA	Destination Address
DP	Destination Port number
GEN	
Off	Offset
Len	Length

Refer to the next section for information on configuring the filter rules.

32.2.1 Configuring a Filter Rule

To configure a filter rule, type its number in **Menu 21.1.1 - Filter Rules Summary** and press [ENTER] to open menu 21.1.1.1 for the rule.

To speed up filtering, all rules in a filter set must be of the same class, that is, protocol filters or generic filters. The class of a filter set is determined by the first rule that you create. When applying the filter sets to a port, separate menu fields are provided for protocol and device filter sets. If you include a protocol filter set in a device filter field or vice versa, the P-793H v2 will warn you and will not allow you to save.

32.2.2 Configuring a TCP/IP Filter Rule

This section shows you how to configure a TCP/IP filter rule. TCP/IP rules allow you to base the rule on the fields in the IP and the upper layer protocol, for example, UDP and TCP headers.

To configure TCP/IP rules, select **TCP/IP Filter Rule** from the **Filter Type** field and press [ENTER] to open **Menu 21.1.1.1 - TCP/IP Filter Rule**, as shown next.

Figure 185 Menu 21.1.1.1: TCP/IP Filter Rule

```

Menu 21.1.1.1 - TCP/IP Filter Rule

Filter #: 1,1
Filter Type= TCP/IP Filter Rule
Active= No
IP Protocol= 0      IP Source Route= No
Destination: IP Addr=
                IP Mask=
                Port #=
                Port # Comp= None
Source: IP Addr=
        IP Mask=
        Port #=
        Port # Comp= None
TCP Estab= N/A
More= No          Log= None
Action Matched= Check Next Rule
Action Not Matched= Check Next Rule

```

The following table describes how to configure your TCP/IP filter rule.

Table 130 Menu 21.1.1.1: TCP/IP Filter Rule

FIELD	DESCRIPTION
Active	Press [SPACE BAR] and then [ENTER] to select Yes to activate the filter rule or No to deactivate it.
IP Protocol	Protocol refers to the upper layer protocol, for example TCP is 6, UDP is 17 and ICMP is 1. Type a value between 0 and 255. A value of 0 matches ANY protocol.
IP Source Route	Press [SPACE BAR] and then [ENTER] to select Yes to apply the rule to packets with an IP source route option. Otherwise the packets must not have a source route option. The majority of IP packets do not have source route.
Destination	
IP Addr	Enter the destination IP Address of the packet you wish to filter. This field is ignored if it is 0.0.0.0.
IP Mask	Enter the IP mask to apply to the Destination: IP Addr .
Port #	Enter the destination port of the packets that you wish to filter. The range of this field is 0 to 65535. This field is ignored if it is 0.
Port # Comp	Press [SPACE BAR] and then [ENTER] to select the comparison to apply to the destination port in the packet against the value given in Destination: Port # . Options are None, Equal, Not Equal, Less and Greater .
Source	

Table 130 Menu 21.1.1.1: TCP/IP Filter Rule

FIELD	DESCRIPTION
IP Addr	Enter the source IP Address of the packet you wish to filter. This field is ignored if it is 0.0.0.0.
IP Mask	Enter the IP mask to apply to the Source: IP Addr .
Port #	Enter the source port of the packets that you wish to filter. The range of this field is 0 to 65535. This field is ignored if it is 0.
Port # Comp	Press [SPACE BAR] and then [ENTER] to select the comparison to apply to the source port in the packet against the value given in Source: Port # . Options are None, Equal, Not Equal, Less and Greater .
TCP Estab	This field is applicable only when the IP Protocol field is 6, TCP. Press [SPACE BAR] and then [ENTER] to select Yes , to have the rule match packets that want to establish a TCP connection (SYN=1 and ACK=0); if No , it is ignored.
More	Press [SPACE BAR] and then [ENTER] to select Yes or No . If Yes , a matching packet is passed to the next filter rule before an action is taken; if No , the packet is disposed of according to the action fields. If More is Yes , then Action Matched and Action Not Matched will be N/A .
Log	Press [SPACE BAR] and then [ENTER] to select a logging option from the following: None – No packets will be logged. Action Matched - Only packets that match the rule parameters will be logged. Action Not Matched - Only packets that do not match the rule parameters will be logged. Both – All packets will be logged.
Action Matched	Press [SPACE BAR] and then [ENTER] to select the action for a matching packet. Options are Check Next Rule, Forward and Drop .
Action Not Matched	Press [SPACE BAR] and then [ENTER] to select the action for a packet not matching the rule. Options are Check Next Rule, Forward and Drop .
When you have Menu 21.1.1.1 - TCP/IP Filter Rule configured, press [ENTER] at the message "Press ENTER to Confirm" to save your configuration, or press [ESC] to cancel. This data will now be displayed on Menu 21.1.1 - Filter Rules Summary .	

The following figure illustrates the logic flow of an IP filter.

Figure 186 Executing an IP Filter

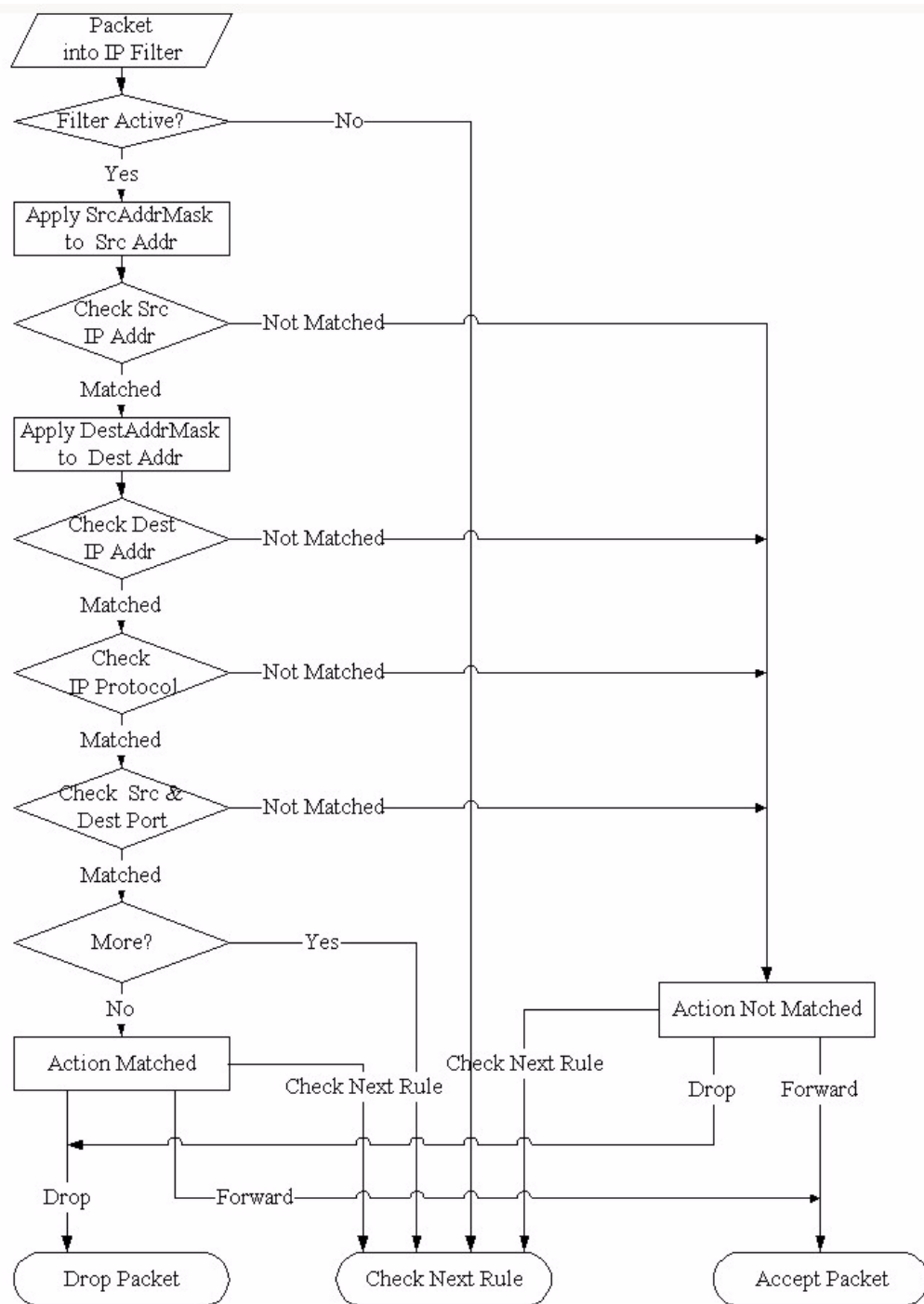

32.2.3 Configuring a Generic Filter Rule

This section shows you how to configure a generic filter rule. The purpose of generic rules is to allow you to filter non-IP packets. For IP, it is generally easier to use the IP rules directly.

For generic rules, the P-793H v2 treats a packet as a byte stream as opposed to an IP or IPX packet. You specify the portion of the packet to check with the **Offset** (from 0) and the **Length** fields, both in bytes. The P-793H v2 applies the Mask (bit-wise ANDing) to the data portion before comparing the result against the Value to determine a match. The **Mask** and **Value** are specified in hexadecimal numbers. Note that it takes two hexadecimal digits to represent a byte, so if the length is 4, the value in either field will take 8 digits, for example, FFFFFFFF.

To configure a generic rule, select **Generic Filter Rule** in the **Filter Type** field in menu 21.1.1.1 and press [ENTER] to open Generic Filter Rule, as shown below.

Figure 187 Menu 21.1.1.1: Generic Filter Rule

```

Menu 21.1.1.1 - Generic Filter Rule

Filter #: 1,1
Filter Type= Generic Filter Rule
Active= No
Offset= 0
Length= 0
Mask= N/A
Value= N/A
More= No           Log= None
Action Matched= Check Next Rule
Action Not Matched= Check Next Rule

```

The following table describes the fields in the **Generic Filter Rule** menu.

Table 131 Menu 21.1.1.1: Generic Filter Rule

FIELD	DESCRIPTION
Filter #	This is the filter set, filter rule co-ordinates, in other words 2,3 refers to the second filter set and the third rule of that set.
Filter Type	Use [SPACE BAR] and then [ENTER] to select a rule type. Parameters displayed below each type will be different. TCP/IP filter rules are used to filter IP packets while generic filter rules allow filtering of non-IP packets. Options are Generic Filter Rule and TCP/IP Filter Rule .
Active	Select Yes to turn on the filter rule or No to turn it off.
Offset	Enter the starting byte of the data portion in the packet that you wish to compare. The range for this field is from 0 to 255.
Length	Enter the byte count of the data portion in the packet that you wish to compare. The range for this field is 0 to 8.

Table 131 Menu 21.1.1.1: Generic Filter Rule (continued)

FIELD	DESCRIPTION
Mask	Enter the mask (in Hexadecimal notation) to apply to the data portion before comparison.
Value	Enter the value (in Hexadecimal notation) to compare with the data portion.
More	If Yes , a matching packet is passed to the next filter rule before an action is taken; else the packet is disposed of according to the action fields. If More is Yes , then Action Matched and Action Not Matched will be No .
Log	Select the logging option from the following: None - No packets will be logged. Action Matched - Only packets that match the rule parameters will be logged. Action Not Matched - Only packets that do not match the rule parameters will be logged. Both - All packets will be logged.
Action Matched	Select the action for a packet matching the rule. Options are Check Next Rule , Forward and Drop .
Action Not Matched	Select the action for a packet not matching the rule. Options are Check Next Rule , Forward and Drop .
Once you have completed filling in Menu 21.1.1.1 - Generic Filter Rule , press [ENTER] at the message "Press ENTER to Confirm" to save your configuration, or press [ESC] to cancel. This data will now be displayed on Menu 21.1.1 - Filter Rules Summary .	

32.3 Example Filter

Let's look at an example to block outside users from accessing the P-793H v2 via telnet. Please see our included disk for more example filters.

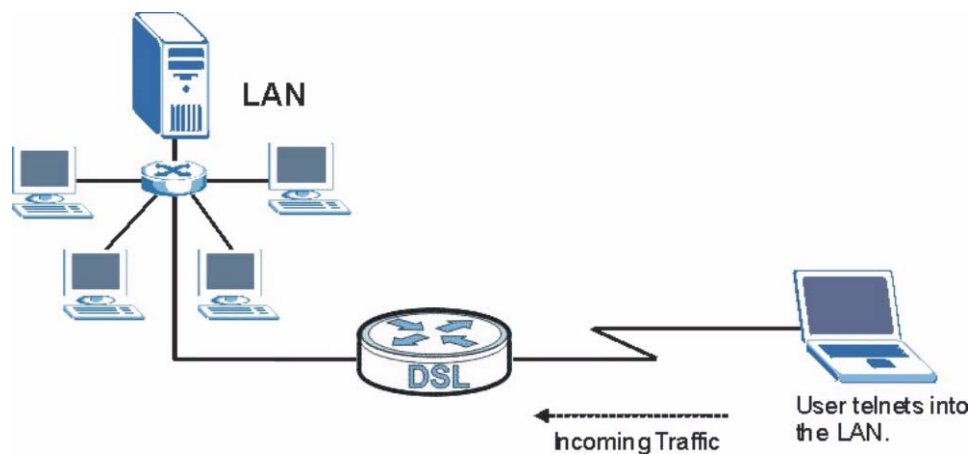
Figure 188 Telnet Filter Example

- 1 Enter 21 from the main menu to open **Menu 21 - Filter and Firewall Setup**.

- 2 Enter 1 to open Menu 21.1 - Filter Set Configuration.
- 3 Enter the index of the filter set you wish to configure (say 3) and press [ENTER].
- 4 Enter a descriptive name or comment in the **Edit Comments** field and press [ENTER].
- 5 Press [ENTER] at the message [Press ENTER to confirm] to open **Menu 21.1.3 - Filter Rules Summary**.
- 6 Enter 1 to configure the first filter rule (the only filter rule of this set). Make the entries in this menu as shown in the following figure.

Figure 189 Example Filter: Menu 21.1.3.1

```
Menu 21.1.3.1 - TCP/IP Filter Rule

Filter #: 3,1
Filter Type= TCP/IP Filter Rule
Active= Yes
IP Protocol= 6      IP Source Route= No
Destination: IP Addr=
               IP Mask=
               Port #= 23
               Port # Comp= Equal
Source: IP Addr=
         IP Mask=
         Port #=
         Port # Comp= None
TCP Estab= No
More= No          Log= None
Action Matched= Drop
Action Not Matched= Forward
```

The port number for the telnet service (TCP protocol) is **23**. See *RFC 1060* for port numbers of well-known services.

When you press [ENTER] to confirm, you will see the following screen. Note that there is only one filter rule in this set.

Figure 190 Example Filter Rules Summary: Menu 21.1.3

Menu 21.1.3 - Filter Rules Summary						
#	A	Type	Filter Rules	M	m	n
1	Y	IP	Pr=6, SA=0.0.0.0, DA=0.0.0.0, DP=23	N	D	F
2	N					
3	N					
4	N					
5	N					
6	N					

This shows you that you have configured and activated (**A = Y**) a TCP/IP filter rule (**Type = IP, Pr = 6**) for destination telnet ports (**DP = 23**).

M = N means an action can be taken immediately. The action is to drop the packet (**m = D**) if the action is matched and to forward the packet immediately (**n = F**) if the action is not matched no matter whether there are more rules to be checked (there aren't in this example).

After you've created the filter set, you must apply it.

- 1 Enter 11 from the main menu to go to menu 11.
- 2 Enter 1 or 2 to open **Menu 11.x - Remote Node Profile**.
- 3 Go to the **Edit Filter Sets** field, press [SPACE BAR] to select **Yes** and press [ENTER].
- 4 This brings you to menu 11.1.4. Apply a filter set (our example filter set 3) as shown in [Figure 152 on page 331](#).
- 5 Press [ENTER] to confirm after you enter the set numbers and to leave menu 11.1.4.

32.4 Filter Types and NAT

There are two classes of filter rules, **Generic Filter** (Device) rules and protocol filter (**TCP/IP**) rules. Generic filter rules act on the raw data from/to LAN and WAN. Protocol filter rules act on the IP packets. Generic and TCP/IP filter rules are discussed in more detail in the next section. When NAT (Network Address

Translation) is enabled, the inside IP address and port number are replaced on a connection-by-connection basis, which makes it impossible to know the exact address and port on the wire. Therefore, the P-793H v2 applies the protocol filters to the “native” IP address and port number before NAT for outgoing packets and after NAT for incoming packets. On the other hand, the generic, or device filters are applied to the raw packets that appear on the wire. They are applied at the point when the P-793H v2 is receiving and sending the packets; in other words the interface. The interface can be an Ethernet port or any other hardware port. The following diagram illustrates this.

Figure 191 Protocol and Device Filter Sets

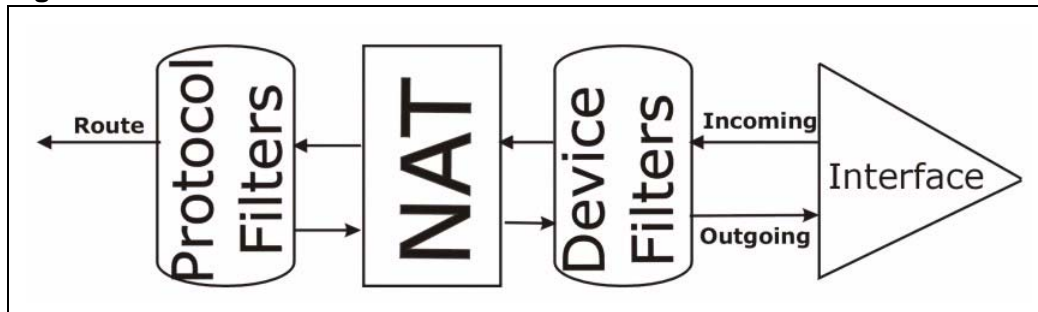

32.5 Firewall Versus Filters

Firewall configuration is discussed in [Chapter 10 on page 149](#). Further comparisons are also made between filtering, NAT and the firewall.

32.6 Applying a Filter

This section shows you where to apply the filter(s) after you design it (them). The P-793H v2 already has filters to prevent NetBIOS traffic from triggering calls, and block incoming telnet, FTP and HTTP connections.

Note: If you do not activate the firewall, it is advisable to apply filters.

32.6.1 Applying LAN Filters

LAN traffic filter sets may be useful to block certain packets, reduce traffic and prevent security breaches. Go to menu 3.1 (shown next) and enter the number(s) of the filter set(s) that you want to apply as appropriate. You can choose up to four filter sets (from twelve) by entering their numbers separated by commas, for

example 3, 4, 6, 11. Input filter sets filter incoming traffic to the P-793H v2 and output filter sets filter outgoing traffic from the P-793H v2.

Figure 192 Filtering LAN Traffic

```
Menu 3.1 - LAN Port Filter Setup

Input Filter Sets:
  protocol filters=
  device filters=
Output Filter Sets:
  protocol filters=
  device filters=
```

32.6.2 Applying Remote Node Filters

Go to menu 11.5 (shown below – note that call filter sets are only present for PPPoA or PPPoE encapsulation) and enter the number(s) of the filter set(s) as appropriate. You can cascade up to four filter sets by entering their numbers separated by commas. The P-793H v2 already has filters to prevent NetBIOS traffic from triggering calls, and block incoming telnet, FTP and HTTP connections.

Figure 193 Filtering Remote Node Traffic

```
Menu 11.5 - Remote Node Filter

Input Filter Sets:
  protocol filters=
  device filters=
Output Filter Sets:
  protocol filters=
  device filters=
Call Filter Sets:
  protocol filters=
  device filters=
```

System Password

Use this menu to change your password. This is the same password used to access the web configurator. To open this menu, enter 23 in the main menu.

Figure 194 Menu 23: System Password

Menu 23 - System Password Old Password= ? New Password= ? Retype to confirm= ?

The following table describes the labels in this menu.

Table 132 Menu 23: System Password

FIELD	DESCRIPTION
Old Password	Enter the current administrator password for the P-793H v2.
New Password	Enter the new administrator password for the P-793H v2.
Retype to confirm	Enter the new administrator password again.

System Information & Diagnosis

This chapter covers SMT menus 24.1 to 24.4.

34.1 Introduction to System Status

This chapter covers the diagnostic tools that help you to maintain your P-793H v2. These tools include updates on system status, port status and log and trace capabilities.

Select menu 24 in the main menu to open **Menu 24 - System Maintenance**, as shown below.

Figure 195 Menu 24: System Maintenance

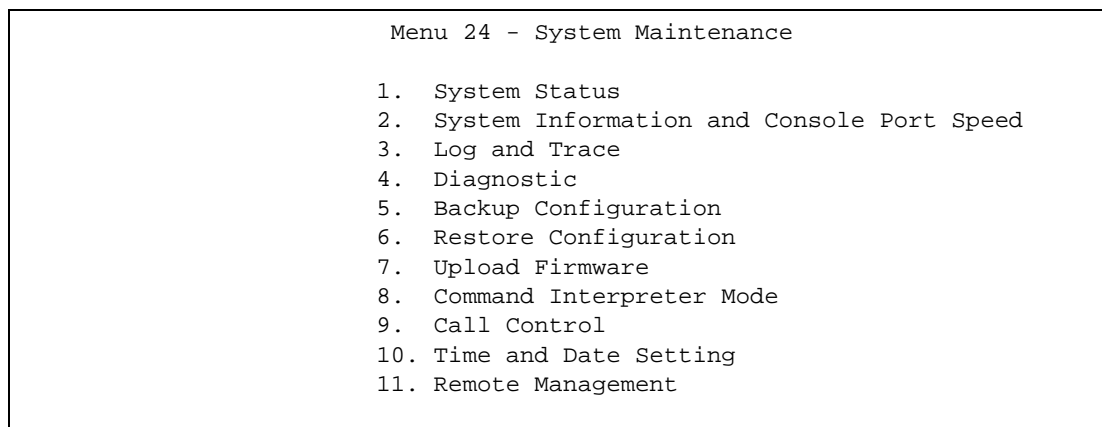

34.2 System Status

The first selection, System Status, gives you information on the version of your system firmware and the status and statistics of the ports, as shown in the next figure. System Status is a tool that can be used to monitor your P-793H v2. Specifically, it gives you information on your system firmware version, number of packets sent and number of packets received.

To get to the System Status:

- 1 Enter number 24 to go to Menu 24 - System Maintenance.
- 2 In this menu, enter 1 to open System Maintenance - Status.
- 3 There are three commands in **Menu 24.1 - System Maintenance - Status**. Entering 1 drops the WAN connection, 9 resets the counters and [ESC] takes you back to the previous screen.

Figure 196 Menu 24.1: System Maintenance - Status

```

Menu 24.1 - System Maintenance - Status                                06:28:45
                                                                    Sat. Jan. 01, 2000
Node-Lnk Status      TxPkts      RxPkts      Errors  Tx B/s  Rx B/s      Up Time
1-ENET  N/A          0           0         0        0        0      0:00:00
2       N/A          0           0         0        0        0      0:00:00
3       N/A          0           0         0        0        0      0:00:00
4       N/A          0           0         0        0        0      0:00:00
5       N/A          0           0         0        0        0      0:00:00
6       N/A          0           0         0        0        0      0:00:00
7       N/A          0           0         0        0        0      0:00:00
8       N/A          0           0         0        0        0      0:00:00

My WAN IP (from ISP): 0.0.0.0

Ethernet:                                                              WAN:
  Status: 100M/Full Duplex Tx Pkts: 4210      Line Status: Down
  Collisions: 0              Rx Pkts: 4466      Transfer Rate: 0 kbps
CPU Load = 1.27%

                                Press Command:
                                COMMANDS: 1-Reset Counters  ESC-Exit

```

The following table describes the fields present in **Menu 24.1 - System Maintenance - Status**. These fields are read-only and meant for diagnostic purposes. The upper right corner of the screen shows the time and date.

Table 133 Menu 24.1: System Maintenance - Status

FIELD	DESCRIPTION
Node-Lnk	This field is the remote node index number and link type (encapsulation).
Status	This field displays Down (line is down), Up (line is up or connected) if you're using Ethernet encapsulation and Down (line is down), Up (line is up or connected), Idle (line (ppp) idle), Dial (starting to trigger a call) and Drop (dropping a call) if you're using PPPoE encapsulation. It displays N/A if the port is not connected.
TxPkts	This is the number of packets transmitted from the P-793H v2 to the remote node.
RxPkts	This is the number of packets received by the P-793H v2 from the remote node.

Table 133 Menu 24.1: System Maintenance - Status (continued)

FIELD	DESCRIPTION
Errors	This is the number of error packets on this connection.
Tx B/s	This field shows the transmission rate in bytes per second on this port.
Rx B/s	This field shows the reception rate in bytes per second on this port.
Up Time	This is the total amount of time the this channel has been connected to the remote node.
My WAN IP (from ISP)	This is the IP address assigned by your ISP or the static IP address you set up in menu 4.
Ethernet:	This section displays information about the LAN ports.
Status	This field displays the speed and duplex settings of the LAN ports.
Collisions	This is the number of collisions on this port.
TxPkts	This is the number of transmitted packets on this port.
RxPkts	This is the number of received packets on this port.
WAN	This section displays information about the WAN port. Note: In a point-to-2points connection this field only displays line 1 status.
Line Status	This field displays the port speed and duplex setting if you're using Ethernet encapsulation and Down (line is down or not connected), Idle (line (ppp) idle), Dial (starting to trigger a call) or Drop (dropping a call) if you're using PPPoE encapsulation.
Transfer Rate	This field shows the transmission speed in kilobits per second on this port.
CPU Load	This field displays the percentage of CPU utilization.
You may enter 1 to reset the counters or [ESC] to return to menu 24.	

34.3 System Information and Console Port Speed

This section describes your system and allows you to choose different console port speeds. To get to the System Information and Console Port Speed:

- 1 Enter 24 to go to **Menu 24 - System Maintenance**.
- 2 Enter 2 to open **Menu 24.2 - System Information and Console Port Speed**.

- 3 From this menu you have two choices as shown in the next figure:

Figure 197 Menu 24.2: System Information and Console Port Speed

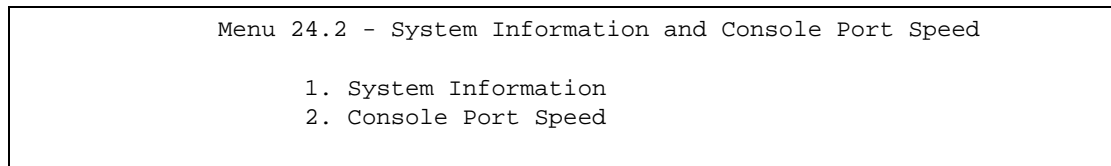

34.3.1 System Information

System Information gives you information about your system as shown below. More specifically, it gives you information on your routing protocol, Ethernet address, IP address, etc.

Figure 198 Menu 24.2.1: System Maintenance - Information

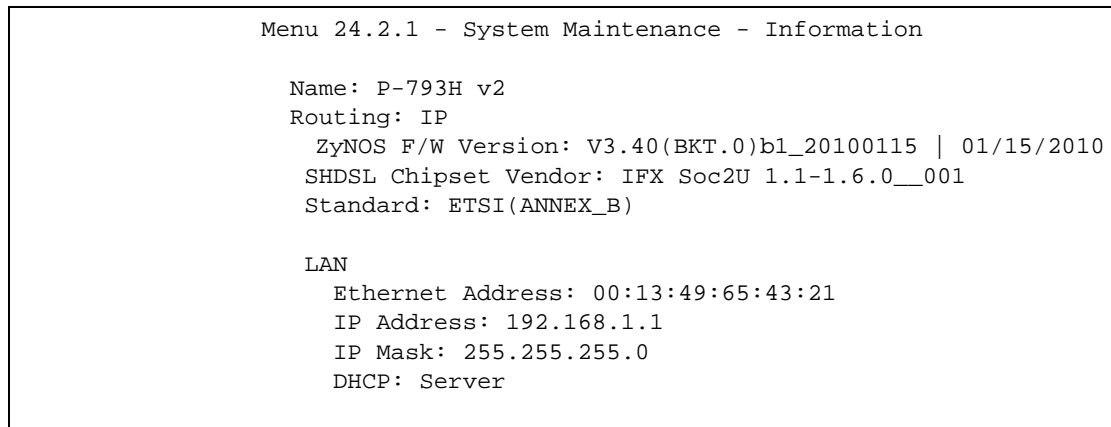

The following table describes the fields in this screen.

Table 134 Menu 24.2.1: System Maintenance - Information

FIELD	DESCRIPTION
Name	This is the P-793H v2's system name + domain name assigned in menu 1. For example, System Name= xxx; Domain Name= baboo.mickey.com Name= xxx.baboo.mickey.com
Routing	Refers to the routing protocol used.
ZyNOS F/W Version	Refers to the version of ZyXEL's Network Operating System software.
SHDSL Chipset Vendor	Refers to the SHDSL chipset inside the P-793H v2.
Standard	This refers to the operational protocol the P-793H v2 and DSLAM (Digital Subscriber Line Access Multiplexer) are using.
LAN	

Table 134 Menu 24.2.1: System Maintenance - Information (continued)

FIELD	DESCRIPTION
Ethernet Address	Refers to the Ethernet MAC (Media Access Control) address of your P-793H v2.
IP Address	This is the IP address of the P-793H v2 in dotted decimal notation.
IP Mask	This shows the IP mask of the P-793H v2.
DHCP	This field shows the DHCP setting of the P-793H v2.
When finished viewing, press [ESC] or [ENTER] to exit.	

34.3.2 Console Port Speed

You can change the speed of the console port through **Menu 24.2.2 – System Maintenance - Change Console Port Speed**. Your P-793H v2 supports 9600 (default), 19200, 38400, 57600, and 115200 bps for the console port. Press [SPACE BAR] and then [ENTER] to select the desired speed in menu 24.2.2, as shown next.

Figure 199 Menu 24.2.2: System Maintenance: Change Console Port Speed

Menu 24.2.2 - System Maintenance - Change Console Port Speed
Console Port Speed: 9600

34.4 Log and Trace

There are two logging facilities in the P-793H v2. The first is the error logs and trace records that are stored locally. The second is the UNIX syslog facility for message logging.

34.4.1 Viewing Error Log

The first place you should look for clues when something goes wrong is the error/trace log. Follow the procedure below to view the local error/trace log:

- 1 Select option 24 from the main menu to open **Menu 24 - System Maintenance**.
- 2 From menu 24, select option 3 to open **Menu 24.3 - System Maintenance - Log and Trace**.
- 3 Select the first option from **Menu 24.3 - System Maintenance - Log and Trace** to display the error log in the system.

After the P-793H v2 finishes displaying, you will have the option to clear the error log.

Figure 200 Menu 24.3: System Maintenance - Log and Trace

```

Menu 24.3 - System Maintenance - Log and Trace

1. View Error Log
2. UNIX Syslog

```

Examples of typical error and information messages are presented in the following figure.

Figure 201 Examples of Error and Information Messages

```

34 Sat Jan 1 00:00:02 2000 PP05 -WARN SNMP TRAP 3: link up
35 Sat Jan 1 00:00:04 2000 PP00 INFO Channel 0 ok
36 Sat Jan 1 00:00:06 2000 PP0c INFO LAN promiscuous mode <0>
37 Sat Jan 1 00:00:06 2000 PP00 -WARN SNMP TRAP 0: cold start
38 Sat Jan 1 00:00:06 2000 PP00 INFO main: init completed
39 Sat Jan 1 00:00:06 2000 PP00 INFO Starting Connectivity Monitor
40 Sat Jan 1 00:00:06 2000 PP18 INFO adjtime task pause 1 day
41 Sat Jan 1 00:00:06 2000 PP19 INFO monitoring WAN connectivity
42 Sat Jan 1 00:00:06 2000 PP06 WARN MPOA Link Down
43 Sat Jan 1 04:10:22 2000 PP0c WARN netMakeChannDial: err=-3001
44 Sat Jan 1 04:10:42 2000 PP10 WARN Last errorlog repeat 18 Times
45 Sat Jan 1 04:10:42 2000 PP10 INFO SMT Password pass
46 Sat Jan 1 04:10:42 2000 PP00 INFO SMT Session Begin
47 Sat Jan 1 04:10:44 2000 PP0c WARN netMakeChannDial: err=-3001
48 Sat Jan 1 04:46:08 2000 PP00 WARN Last errorlog repeat 216 Times
49 Sat Jan 1 04:46:08 2000 PP00 INFO SMT Session End
51 Sat Jan 1 04:46:59 2000 PP0c WARN netMakeChannDial: err=-3001
52 Sat Jan 1 04:58:00 2000 PP10 WARN Last errorlog repeat 65 Times
53 Sat Jan 1 04:58:00 2000 PP10 INFO SMT Password pass
Clear Error Log (y/n):

```

34.4.2 Syslog Logging

The P-793H v2 uses the syslog facility to log the CDR (Call Detail Record) and system messages to a syslog server. Syslog and accounting can be configured in **Menu 24.3.2 - System Maintenance - Syslog Logging**, as shown next.

Figure 202 Menu 24.3.2: System Maintenance - UNIX Syslog

```

Menu 24.3.2 - System Maintenance - UNIX Syslog

UNIX Syslog:
Active= No
Syslog IP Address= 0.0.0.0
Log Facility= Local 1

```

You need to configure the syslog parameters described in the following table to activate syslog then choose what you want to log.

Table 135 Menu 24.3.2: System Maintenance - UNIX Syslog

FIELD	DESCRIPTION
UNIX Syslog:	
Active	Press [SPACE BAR] and then [ENTER] to turn syslog on or off.
Syslog IP Address	Enter the server name or IP address of the syslog server that will log the selected categories of logs.
Log Facility	Press [SPACE BAR] and then [ENTER] to select a location. The log facility allows you to log the messages to different files in the syslog server. Refer to the documentation of your syslog program for more details.
When finished configuring this screen, press [ENTER] to confirm or [ESC] to cancel.	

Your P-793H v2 sends five types of syslog messages. Some examples (not all P-793H v2 specific) of these syslog messages with their message formats are shown next:

1 CDR

CDR Message Format

```
SdcmdSyslogSend( SYSLOG_CDR, SYSLOG_INFO, String );
String = board xx line xx channel xx, call xx, str
board = the hardware board ID
line = the WAN ID in a board
Channel = channel ID within the WAN
call = the call reference number which starts from 1 and increments by 1 for each
new call
str = C01 Outgoing Call dev xx ch xx (dev:device No. ch:channel No.)
    L02 Tunnel Connected(L2TP)
    C02 OutCall Connected xxxx (means connected speed) xxxxx (means Remote
Call Number)
    L02 Call Terminated
    C02 Call Terminated
Jul 19 11:19:27 192.168.102.2 ZyXEL: board 0 line 0 channel 0, call 1, C01 Outgoing
Call dev=2 ch=0 40002
Jul 19 11:19:32 192.168.102.2 ZyXEL: board 0 line 0 channel 0, call 1, C02 OutCall
Connected 64000 40002
Jul 19 11:20:06 192.168.102.2 ZyXEL: board 0 line 0 channel 0, call 1, C02 Call
Terminated
```

2 Packet triggered

Packet triggered Message Format

```
SdcmdSyslogSend( SYSLOG_PKTTRI, SYSLOG_NOTICE, String );
String = Packet trigger: Protocol=xx Data=xxxxxxxxx....x
Protocol: (1: IP 2: IPX 3: IPXHC 4: BPDU 5: ATALK 6: IPNG)
Data: We will send forty-eight Hex characters to the server
Jul 19 11:28:39 192.168.102.2 ZyXEL: Packet Trigger: Protocol=1,
Data=4500003c100100001f010004c0a86614ca849a7b08004a5c0200010061626364
65666768696a6b6c6d6e6f7071727374
Jul 19 11:28:56 192.168.102.2 ZyXEL: Packet Trigger: Protocol=1,
Data=4500002c1b0140001f06b50ec0a86614ca849a7b0427001700195b3e00000000
600220008cd40000020405b4
Jul 19 11:29:06 192.168.102.2 ZyXEL: Packet Trigger: Protocol=1,
Data=45000028240140001f06ac12c0a86614ca849a7b0427001700195b451d143013
5004000077600000
```

3 Filter log

<p>Filter log Message Format</p> <p>SdcmdSyslogSend(SYSLOG_FILLOG, SYSLOG_NOTICE, String);</p> <p>String = IP[Src=xx.xx.xx.xx Dst=xx.xx.xx.xx prot spo=xxxx dpo=xxxx] S04>R01mD</p> <p>IP[...] is the packet header and S04>R01mD means filter set 4 (S) and rule 1 (R), match (m) drop (D).</p> <p> Src: Source Address</p> <p> Dst: Destination Address</p> <p> prot: Protocol ("TCP", "UDP", "ICMP")</p> <p> spo: Source port</p> <p> dpo: Destination port</p> <p>Mar 03 10:39:43 202.132.155.97 ZyXEL: GEN[ffffffffnordff0080] }S05>R01mF</p> <p>Mar 03 10:41:29 202.132.155.97 ZyXEL: GEN[00a0c5f502fnord010080] }S05>R01mF</p> <p>Mar 03 10:41:34 202.132.155.97 ZyXEL: IP[Src=192.168.2.33 Dst=202.132.155.93 ICMP]}S04>R01mF</p> <p>Mar 03 11:59:20 202.132.155.97 ZyXEL: GEN[00a0c5f502fnord010080] }S05>R01mF</p> <p>Mar 03 12:00:52 202.132.155.97 ZyXEL: GEN[ffffffffff0080] }S05>R01mF</p> <p>Mar 03 12:00:57 202.132.155.97 ZyXEL: GEN[00a0c5f502010080] }S05>R01mF</p> <p>Mar 03 12:01:06 202.132.155.97 ZyXEL: IP[Src=192.168.2.33 Dst=202.132.155.93 TCP spo=01170 dpo=00021]}S04>R01mF</p>
--

4 PPP log

PPP Log Message Format
SdcmSyslogSend(SYSLOG_PPLOG, SYSLOG_NOTICE, String);
String = ppp:Proto Starting / ppp:Proto Opening / ppp:Proto Closing / ppp:Proto Shutdown
Proto = LCP / ATCP / BACP / BCP / CBCP / CCP / CHAP/ PAP / IPCP / IPXCP
Jul 19 11:42:44 192.168.102.2 ZyXEL: ppp:LCP Closing
Jul 19 11:42:49 192.168.102.2 ZyXEL: ppp:IPCP Closing
Jul 19 11:42:54 192.168.102.2 ZyXEL: ppp:CCP Closing

5 Firewall log

Firewall Log Message Format
SdcmSyslogSend(SYSLOG_FIREWALL, SYSLOG_NOTICE, buf);
buf = IP[Src=xx.xx.xx.xx : spo=xxxx Dst=xx.xx.xx.xx : dpo=xxxx prot rule action]
Src: Source Address
spo: Source port (empty means no source port information)
Dst: Destination Address
dpo: Destination port (empty means no destination port information)
prot: Protocol ("TCP", "UDP", "ICMP", "IGMP", "GRE", "ESP")
rule: <a,b> where a means "set" number; b means "rule" number.
Action: nothing(N) block (B) forward (F)
08-01-200011:48:41Local1.Notice192.168.10.10RAS: FW 172.21.1.80 :137 ->172.21.1.80 :137 UDP default permit:<2,0> B
08-01-200011:48:41Local1.Notice192.168.10.10RAS: FW 192.168.77.88 :520 ->192.168.77.88 :520 UDP default permit:<2,0> B
08-01-200011:48:39Local1.Notice192.168.10.10RAS: FW 172.21.1.50 ->172.21.1.50 IGMP<2> default permit:<2,0> B
08-01-200011:48:39Local1.Notice192.168.10.10RAS: FW 172.21.1.25 ->172.21.1.25 IGMP<2> default permit:<2,0> B

34.5 Diagnostic

The diagnostic facility allows you to test the different aspects of your P-793H v2 to determine if it is working properly. Menu 24.4 allows you to choose among various

types of diagnostic tests to evaluate your system, as shown next. Not all fields are available on all models.

Follow the procedure below to get to **Menu 24.4 - System Maintenance - Diagnostic**.

- 1 From the main menu, select option 24 to open **Menu 24 - System Maintenance**.
- 2 From this menu, select option 4. Diagnostic. This will open **Menu 24.4 - System Maintenance - Diagnostic**.

Figure 203 Menu 24.4: System Maintenance - Diagnostic

```

Menu 24.4 - System Maintenance - Diagnostic

xDSL                                     System
  1. Reset xDSL                          21. Reboot System
                                           22. Command Mode

TCP/IP
  12. Ping Host

Enter Menu Selection Number:

Host IP Address= N/A

```

The following table describes the labels in this screen.

Table 136 Menu 24.4: System Maintenance - Diagnostic

FIELD	DESCRIPTION
Reset xDSL	Enter 1 to reset the DSL connection on the WAN port.
Ping Host	Enter 12 to ping any machine (with an IP address) on your LAN or WAN. Enter its IP address in the Host IP Address field below.
Reboot System	Enter 11 to reboot the P-793H v2.
Command Mode	Enter 22 to go to the Command Interpreter (CI) for further diagnosis. You can also enter the CI using menu 24.8.
Host IP Address	If you entered 1 in the Enter Menu Selection Number field, then enter the IP address of the computer you want to ping in this field.
Enter the number of the selection you would like to perform or press [ESC] to cancel.	

Firmware and Configuration File Maintenance

This chapter tells you how to back up and restore your configuration file as well as upload new firmware and a new configuration file.

35.1 Introduction

Use the instructions in this chapter to change the P-793H v2's configuration file or upgrade its firmware. After you configure your P-793H v2, you can backup the configuration file to a computer. That way if you later misconfigure the P-793H v2, you can upload the backed up configuration file to return to your previous settings. You can alternately upload the factory default configuration file if you want to return the P-793H v2 to the original default settings. The firmware determines the P-793H v2's available features and functionality. You can download new firmware releases from your nearest ZyXEL FTP site to use to upgrade your P-793H v2's performance.

35.2 Filename Conventions

The configuration file (often called the romfile or rom-0) contains the factory default settings in the menus such as password, DHCP Setup, TCP/IP Setup, etc. It arrives from ZyXEL with a "rom" filename extension. Once you have customized the P-793H v2's settings, they can be saved back to your computer under a filename of your choosing.

ZyNOS (ZyXEL Network Operating System sometimes referred to as the "ras" file) is the system firmware and has a "bin" filename extension. With many FTP and TFTP clients, the filenames are similar to those seen next.

```
ftp> put firmware.bin ras
```

This is a sample FTP session showing the transfer of the computer file "firmware.bin" to the P-793H v2.

```
ftp> get rom-0 config.cfg
```

This is a sample FTP session saving the current configuration to the computer file "config.cfg".

If your (T)FTP client does not allow you to have a destination filename different than the source, you will need to rename them as the P-793H v2 only recognizes "rom-0" and "ras". Be sure you keep unaltered copies of both files for later use.

The following table is a summary. Please note that the internal filename refers to the filename on the P-793H v2 and the external filename refers to the filename not on the P-793H v2, that is, on your computer, local network or FTP site and so the name (but not the extension) may vary. After uploading new firmware, see the **ZyNOS F/W Version** field in **Menu 24.2.1 - System Maintenance - Information** to confirm that you have uploaded the correct firmware version. The AT command is the command you enter after you press "y" when prompted in the SMT menu to go into debug mode.

Table 137 Filename Conventions

FILE TYPE	INTERNAL NAME	EXTERNAL NAME	DESCRIPTION
Configuration File	Rom-0	This is the configuration filename on the P-793H v2. Uploading the rom-0 file replaces the entire ROM file system, including your P-793H v2 configurations, system-related data (including the default password), the error log and the trace log.	*.rom
Firmware	Ras	This is the generic name for the ZyNOS firmware on the P-793H v2.	*.bin

35.3 Backup Configuration

Note: The P-793H v2 displays different messages explaining different ways to backup, restore and upload files in menus 24.5, 24.6, 24.7.1 and 24.7.2 depending on whether you use the console port or Telnet.

Option 5 from **Menu 24 - System Maintenance** allows you to backup the current P-793H v2 configuration to your computer. Backup is highly recommended once your P-793H v2 is functioning properly. FTP is the preferred method for backing up your current configuration to your computer since it is faster. You can also perform backup and restore using menu 24 through the console port. Any serial communications program should work fine; however, you must use Xmodem protocol to perform the download/upload and you don't have to rename the files.

Please note that terms "download" and "upload" are relative to the computer. Download means to transfer from the P-793H v2 to the computer, while upload means from your computer to the P-793H v2.

35.3.1 Backup Configuration

Follow the instructions as shown in the next screen.

Figure 204 Menu 24.5: Backup Configuration

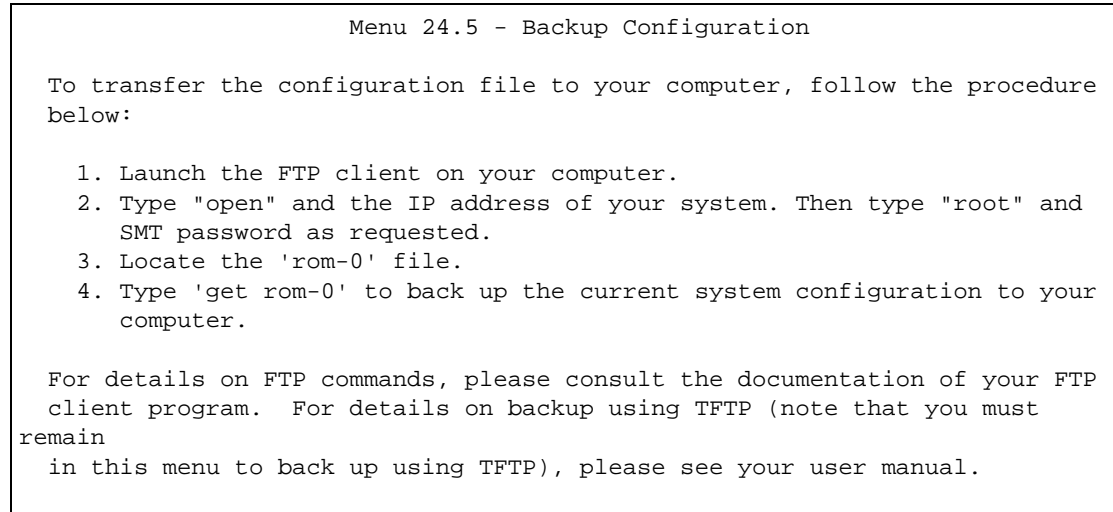

35.3.2 Using the FTP Command from the Command Line

- 1 Launch the FTP client on your computer.
- 2 Enter "open", followed by a space and the IP address of your P-793H v2.
- 3 Press [ENTER] when prompted for a username.
- 4 Enter your password as requested (the default is "1234").
- 5 Enter "bin" to set transfer mode to binary.
- 6 Use "get" to transfer files from the P-793H v2 to the computer, for example, "get rom-0 config.rom" transfers the configuration file on the P-793H v2 to your computer and renames it "config.rom". See earlier in this chapter for more information on filename conventions.
- 7 Enter "quit" to exit the ftp prompt.

35.3.3 Example of FTP Commands from the Command Line

Figure 205 FTP Session Example

```

331 Enter PASS command
Password:
230 Logged in
ftp> bin
200 Type I OK
ftp> get rom-0 zyxel.rom
200 Port command okay
150 Opening data connection for STOR ras
226 File received OK
ftp: 16384 bytes sent in 1.10Seconds 297.89Kbytes/sec.
ftp> quit

```

35.3.4 GUI-based FTP Clients

The following table describes some of the commands that you may see in GUI-based FTP clients.

Table 138 General Commands for GUI-based FTP Clients

COMMAND	DESCRIPTION
Host Address	Enter the address of the host server.
Login Type	Anonymous. This is when a user I.D. and password is automatically supplied to the server for anonymous access. Anonymous logins will work only if your ISP or service administrator has enabled this option. Normal. The server requires a unique User ID and Password to login.
Transfer Type	Transfer files in either ASCII (plain text format) or in binary mode. Configuration and firmware files should be transferred in binary mode
Initial Remote Directory	Specify the default remote directory (path).
Initial Local Directory	Specify the default local directory (path).

35.3.5 File Maintenance Over WAN

TFTP, FTP and Telnet over the WAN will not work when:

- 1 The firewall is active (turn the firewall off in menu 21.2 or create a firewall rule to allow access from the WAN).
- 2 You have disabled Telnet service in menu 24.11.

- 3 You have applied a filter in menu 3.1 (LAN) or in menu 11.5 (WAN) to block Telnet service.
- 4 The IP you entered in the **Secured Client IP** field in menu 24.11 does not match the client IP. If it does not match, the P-793H v2 will disconnect the Telnet session immediately.
- 5 You have an SMT console session running.

35.3.6 Backup Configuration Using TFTP

The P-793H v2 supports the up/downloading of the firmware and the configuration file using TFTP (Trivial File Transfer Protocol) over LAN. Although TFTP should work over WAN as well, it is not recommended.

To use TFTP, your computer must have both telnet and TFTP clients. To backup the configuration file, follow the procedure shown next.

- 1 Use telnet from your computer to connect to the P-793H v2 and log in. Because TFTP does not have any security checks, the P-793H v2 records the IP address of the telnet client and accepts TFTP requests only from this address.
- 2 Put the SMT in command interpreter (CI) mode by entering 8 in **Menu 24 – System Maintenance**.
- 3 Enter command “sys stdio 0” to disable the SMT timeout, so the TFTP transfer will not be interrupted. Enter command “sys stdio 5” to restore the five-minute SMT timeout (default) when the file transfer is complete.
- 4 Launch the TFTP client on your computer and connect to the P-793H v2. Set the transfer mode to binary before starting data transfer.
- 5 Use the TFTP client (see the example below) to transfer files between the P-793H v2 and the computer. The file name for the configuration file is “rom-0” (rom-zero, not capital o).

Note that the telnet connection must be active and the SMT in CI mode before and during the TFTP transfer. For details on TFTP commands (see following example), please consult the documentation of your TFTP client program. For UNIX, use “get” to transfer from the P-793H v2 to the computer and “binary” to set binary transfer mode.

35.3.7 TFTP Command Example

The following is an example TFTP command:

```
tftp [-i] host get rom-0 config.rom
```

Where “i” specifies binary image transfer mode (use this mode when transferring binary files), “host” is the P-793H v2 IP address, “get” transfers the file source on the P-793H v2 (rom-0, name of the configuration file on the P-793H v2) to the file destination on the computer and renames it config.rom.

35.3.8 GUI-based TFTP Clients

The following table describes some of the fields that you may see in GUI-based TFTP clients.

Table 139 General Commands for GUI-based TFTP Clients

COMMAND	DESCRIPTION
Host	Enter the IP address of the P-793H v2. 192.168.1.1 is the P-793H v2's default IP address when shipped.
Send/Fetch	Use “Send” to upload the file to the P-793H v2 and “Fetch” to back up the file on your computer.
Local File	Enter the path and name of the firmware file (*.bin extension) or configuration file (*.rom extension) on your computer.
Remote File	This is the filename on the P-793H v2. The filename for the firmware is “ras” and for the configuration file, is “rom-0”.
Binary	Transfer the file in binary mode.
Abort	Stop transfer of the file.

Refer to [Section 35.3.5 on page 390](#) to read about configurations that disallow TFTP and FTP over WAN.

35.3.9 Backup Via Console Port

Back up configuration via console port by following the HyperTerminal procedure shown next. Procedures using other serial communications programs should be similar.

- 1 Display menu 24.5 and enter “y” at the following screen.

Figure 206 System Maintenance: Backup Configuration

```
Ready to backup Configuration via Xmodem.
Do you want to continue (y/n):
```

- 2 The following screen indicates that the Xmodem download has started.

Figure 207 System Maintenance: Starting Xmodem Download Screen

```
You can enter ctrl-x to terminate operation any time.
Starting XMODEM download...
```

- 3 Run the HyperTerminal program by clicking **Transfer**, then **Receive File** as shown in the following screen.

Figure 208 Backup Configuration Example

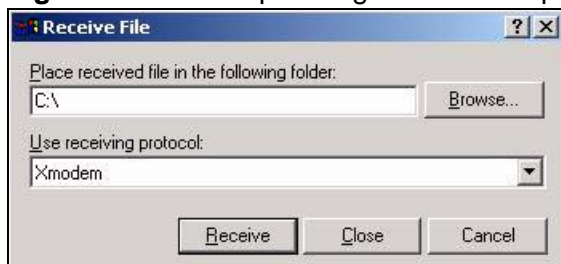

Type a location for storing the configuration file or click **Browse** to look for one.

Choose the **Xmodem** protocol.

Then click **Receive**.

- 4 After a successful backup you will see the following screen. Press any key to return to the SMT menu.

Figure 209 Successful Backup Confirmation Screen

```
** Backup Configuration completed. OK.
### Hit any key to continue.###
```

35.4 Restore Configuration

This section shows you how to restore a previously saved configuration. Note that this function erases the current configuration before restoring a previous back up configuration; please do not attempt to restore unless you have a backup configuration file stored on disk.

FTP is the preferred method for restoring your current computer configuration to your P-793H v2 since FTP is faster. Please note that you must wait for the system to automatically restart after the file transfer is complete.

Do not interrupt the file transfer process as this may PERMANENTLY DAMAGE YOUR P-793H v2. When the Restore Configuration process is complete, the P-793H v2 will automatically restart.

35.4.1 Restore Using FTP

For details about backup using (T)FTP please refer to earlier sections on FTP and TFTP file upload in this chapter.

Figure 210 Menu 24.6: Restore Configuration

Menu 24.6 - Restore Configuration

To transfer the firmware and the configuration file, follow the procedure below:

1. Launch the FTP client on your computer.
2. Type "open" and the IP address of your system. Then type "root" and SMT password as requested.
3. Type "put backupfilename rom-0" where backupfilename is the name of your backup configuration file on your computer and rom-0 is the remote file name on the system. This restores the configuration to your system.
4. The system reboots automatically after a successful file transfer.

For details on FTP commands, please consult the documentation of your FTP client program. For details on restoring using TFTP (note that you must remain on this menu to restore using TFTP), please see your user manual.

- 1 Launch the FTP client on your computer.
- 2 Enter "open", followed by a space and the IP address of your P-793H v2.
- 3 Press [ENTER] when prompted for a username.
- 4 Enter your password as requested (the default is "1234").
- 5 Enter "bin" to set transfer mode to binary.
- 6 Find the "rom" file (on your computer) that you want to restore to your P-793H v2.
- 7 Use "put" to transfer files from the P-793H v2 to the computer, for example, "put config.rom rom-0" transfers the configuration file "config.rom" on your computer to the P-793H v2. See earlier in this chapter for more information on filename conventions.

- 8 Enter "quit" to exit the ftp prompt. The P-793H v2 will automatically restart after a successful restore process.

35.4.2 Restore Using FTP Session Example

Figure 211 Restore Using FTP Session Example

```
ftp> put config.rom rom-0
200 Port command okay
150 Opening data connection for STOR rom-0
226 File received OK
221 Goodbye for writing flash
ftp: 16384 bytes sent in 0.06Seconds 273.07Kbytes/sec.
ftp>quit
```

Refer to [Section 35.3.5 on page 390](#) to read about configurations that disallow TFTP and FTP over WAN.

35.4.3 Restore Via Console Port

Restore configuration via console port by following the HyperTerminal procedure shown next. Procedures using other serial communications programs should be similar.

- 1 Display menu 24.6 and enter "y" at the following screen.

Figure 212 System Maintenance: Restore Configuration

```
Ready to restore Configuration via Xmodem.
Do you want to continue (y/n):
```

- 2 The following screen indicates that the Xmodem download has started.

Figure 213 System Maintenance: Starting Xmodem Download Screen

```
Starting XMODEM download (CRC mode) ...CCCCCCCC
```

- 3 Run the HyperTerminal program by clicking **Transfer**, then **Send File** as shown in the following screen.

Figure 214 Restore Configuration Example

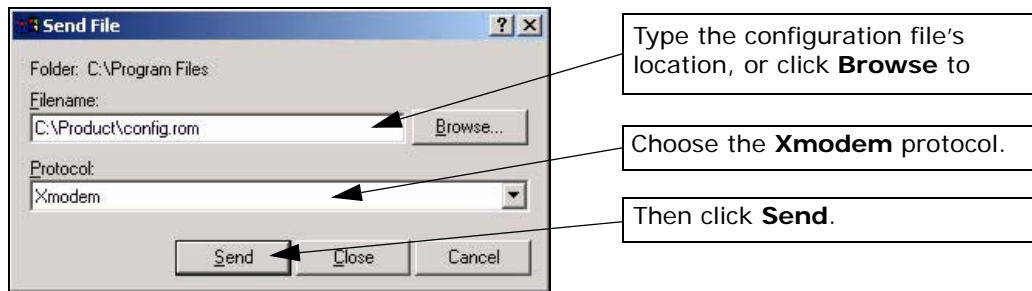

- 4 After a successful restoration you will see the following screen. Press any key to restart the P-793H v2 and return to the SMT menu.

Figure 215 Successful Restoration Confirmation Screen

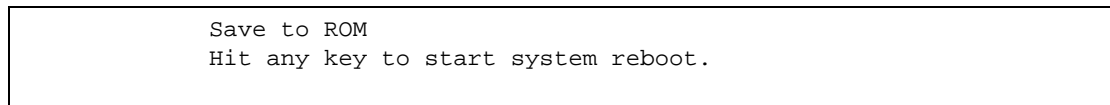

35.5 Uploading Firmware and Configuration Files

This section shows you how to upload firmware and configuration files. You can upload configuration files by following the procedure in [Section 35.4 on page 393](#) or by following the instructions in **Menu 24.7.2 - System Maintenance - Upload System Configuration File** (for console port).

Do not interrupt the file transfer process as this may PERMANENTLY DAMAGE YOUR P-793H v2.

35.5.1 Firmware File Upload

FTP is the preferred method for uploading the firmware and configuration. To use this feature, your computer must have an FTP client.

When you telnet into the P-793H v2, you will see the following screens for uploading firmware and the configuration file using FTP.

Figure 216 Menu 24.7.1: System Maintenance - Upload System Firmware

```
Menu 24.7.1 - System Maintenance - Upload System Firmware

To upload the system firmware, follow the procedure below:

1. Launch the FTP client on your workstation.
2. Type "open" and the IP address of your system. Then type "root" and
   SMT password as requested.
3. Type "put firmwarefilename ras" where "firmwarefilename" is the name
   of your firmware upgrade file on your workstation and "ras" is the
   remote file name on the system.
4. The system reboots automatically after a successful firmware upload.

For details on FTP commands, please consult the documentation of your FTP
client program. For details on uploading system firmware using TFTP (note
that you must remain on this menu to upload system firmware using TFTP),
please see your manual.
```

35.5.2 Configuration File Upload

You see the following screen when you telnet into menu 24.7.2.

Figure 217 Menu 24.7.2: System Maintenance - Upload System Configuration File

```
Menu 24.7.2 - System Maintenance - Upload System Configuration File

To upload the system configuration file, follow the procedure below:

1. Launch the FTP client on your workstation.
2. Type "open" and the IP address of your system. Then type "root" and
   SMT password as requested.
3. Type "put configurationfilename rom-0" where "configurationfilename"
   is the name of your system configuration file on your workstation,
   which will be transferred to the "rom-0" file on the system.
4. The system reboots automatically after the upload system
   configuration file process is complete.

For details on FTP commands, please consult the documentation of your FTP
client program. For details on uploading system firmware using TFTP (note
that you must remain on this menu to upload system firmware using TFTP),
please see your manual.
```

To upload the firmware and the configuration file, follow these examples

35.5.3 FTP File Upload Command from the DOS Prompt Example

- 1 Launch the FTP client on your computer.
- 2 Enter "open", followed by a space and the IP address of your P-793H v2.
- 3 Press [ENTER] when prompted for a username.
- 4 Enter your password as requested (the default is "1234").
- 5 Enter "bin" to set transfer mode to binary.
- 6 Use "put" to transfer files from the computer to the P-793H v2, for example, "put firmware.bin ras" transfers the firmware on your computer (firmware.bin) to the P-793H v2 and renames it "ras". Similarly, "put config.rom rom-0" transfers the configuration file on your computer (config.rom) to the P-793H v2 and renames it "rom-0". Likewise "get rom-0 config.rom" transfers the configuration file on the P-793H v2 to your computer and renames it "config.rom." See earlier in this chapter for more information on filename conventions.
- 7 Enter "quit" to exit the ftp prompt.

35.5.4 FTP Session Example of Firmware File Upload

Figure 218 FTP Session Example of Firmware File Upload

```
331 Enter PASS command
Password:
230 Logged in
ftp> bin
200 Type I OK
ftp> put firmware.bin ras
200 Port command okay
150 Opening data connection for STOR ras
226 File received OK
ftp: 1103936 bytes sent in 1.10Seconds 297.89Kbytes/sec.
ftp> quit
```

More commands (found in GUI-based FTP clients) are listed earlier in this chapter.

Refer to [Section 35.3.5 on page 390](#) to read about configurations that disallow TFTP and FTP over WAN.

35.5.5 TFTP File Upload

The P-793H v2 also supports the uploading of firmware files using TFTP (Trivial File Transfer Protocol) over LAN. Although TFTP should work over WAN as well, it is not recommended.

To use TFTP, your computer must have both telnet and TFTP clients. To transfer the firmware and the configuration file, follow the procedure shown next.

- 1 Use telnet from your computer to connect to the P-793H v2 and log in. Because TFTP does not have any security checks, the P-793H v2 records the IP address of the telnet client and accepts TFTP requests only from this address.
- 2 Put the SMT in command interpreter (CI) mode by entering 8 in **Menu 24 – System Maintenance**.
- 3 Enter the command “sys stdio 0” to disable the console timeout, so the TFTP transfer will not be interrupted. Enter “command sys stdio 5” to restore the five-minute console timeout (default) when the file transfer is complete.
- 4 Launch the TFTP client on your computer and connect to the P-793H v2. Set the transfer mode to binary before starting data transfer.
- 5 Use the TFTP client (see the example below) to transfer files between the P-793H v2 and the computer. The file name for the firmware is “ras”.

Note that the telnet connection must be active and the P-793H v2 in CI mode before and during the TFTP transfer. For details on TFTP commands (see following example), please consult the documentation of your TFTP client program. For UNIX, use “get” to transfer from the P-793H v2 to the computer, “put” the other way around, and “binary” to set binary transfer mode.

35.5.6 TFTP Upload Command Example

The following is an example TFTP command:

```
tftp [-i] host put firmware.bin ras
```

Where “i” specifies binary image transfer mode (use this mode when transferring binary files), “host” is the P-793H v2’s IP address, “put” transfers the file source on the computer (firmware.bin – name of the firmware on the computer) to the file destination on the remote host (ras - name of the firmware on the P-793H v2).

Commands that you may see in GUI-based TFTP clients are listed earlier in this chapter.

35.5.7 Uploading Via Console Port

FTP or TFTP are the preferred methods for uploading firmware to your P-793H v2. However, in the event of your network being down, uploading files is only possible with a direct connection to your P-793H v2 via the console port. Uploading files via the console port under normal conditions is not recommended since FTP or TFTP is faster. Any serial communications program should work fine; however, you must use the Xmodem protocol to perform the download/upload.

35.5.8 Uploading Firmware File Via Console Port

- 1 Select 1 from Menu 24.7 – System Maintenance – Upload Firmware to display Menu 24.7.1 - System Maintenance - Upload System Firmware, and then follow the instructions as shown in the following screen.

Figure 219 Menu 24.7.1 As Seen Using the Console Port

```
Menu 24.7.1 - System Maintenance - Upload System Firmware

To upload system firmware:
1. Enter "y" at the prompt below to go into debug mode.
2. Enter "atur" after "Enter Debug Mode" message.
3. Wait for "Starting XMODEM upload" message before activating
Xmodem upload on your terminal.
4. After successful firmware upload, enter "atgo" to restart the router.

Warning: Proceeding with the upload will erase the current system
firmware.

Do You Wish To Proceed:(Y/N)
```

- 2 After the "Starting Xmodem upload" message appears, activate the Xmodem protocol on your computer. Follow the procedure as shown previously for the HyperTerminal program. The procedure for other serial communications programs should be similar.

35.5.9 Example Xmodem Firmware Upload Using HyperTerminal

Click **Transfer**, then **Send File** to display the following screen.

Figure 220 Example Xmodem Upload

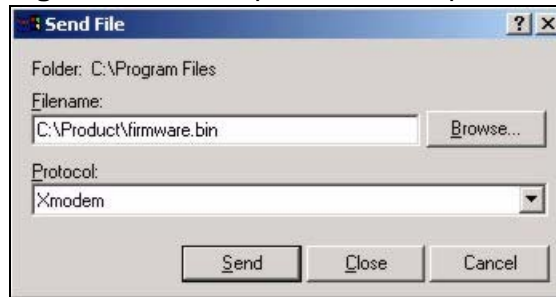

After the firmware upload process has completed, the P-793H v2 will automatically restart.

35.5.10 Uploading Configuration File Via Console Port

- 1 Select 2 from Menu 24.7 – System Maintenance – Upload Firmware to display Menu 24.7.2 - System Maintenance - Upload System Configuration File. Follow the instructions as shown in the next screen.

Figure 221 Menu 24.7.2 As Seen Using the Console Port

```

Menu 24.7.2 - System Maintenance - Upload System Configuration File

To upload system configuration file:
1. Enter "y" at the prompt below to go into debug mode.
2. Enter "atlc" after "Enter Debug Mode" message.
3. Wait for "Starting XMODEM upload" message before activating
   Xmodem upload on your terminal.
4. After successful firmware upload, enter "atgo" to restart
   the system.

Warning:
1. Proceeding with the upload will erase the current
   configuration file.
2. The system's console port speed (Menu 24.2.2) may change when it is
   restarted; please adjust your terminal's speed accordingly. The password
   may change (menu 23), also.
3. When uploading the DEFAULT configuration file, the console
   port speed will be reset to 9600 bps and the password to "1234".

Do You Wish To Proceed:(Y/N)

```

- 2 After the "Starting Xmodem upload" message appears, activate the Xmodem protocol on your computer. Follow the procedure as shown previously for the HyperTerminal program. The procedure for other serial communications programs should be similar.
- 3 Enter "atgo" to restart the P-793H v2.

35.5.11 Example Xmodem Configuration Upload Using HyperTerminal

Click **Transfer**, then **Send File** to display the following screen.

Figure 222 Example Xmodem Upload

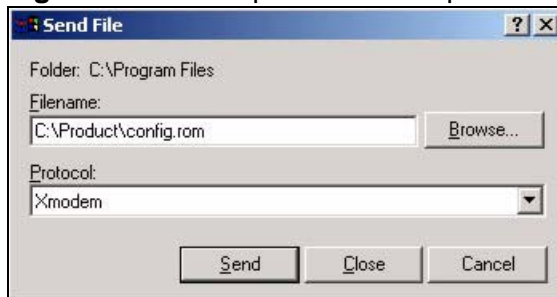

After the configuration upload process has completed, restart the P-793H v2 by entering "atgo".

Menus 24.8 to 24.11

This chapter leads you through SMT menus 24.8 to 24.11.

36.1 Command Interpreter Mode

The Command Interpreter (CI) is a part of the main router firmware. The CI provides much of the same functionality as the SMT, while adding some low-level setup and diagnostic functions. Enter the CI from the SMT by selecting menu 24.8. Access can be by Telnet or by a connection to the console port, although some commands are only available with a console connection. See the included disk or zyxel.com for more detailed information on CI commands. Enter 8 from **Menu 24 - System Maintenance**.

Use of undocumented commands or misconfiguration can damage the unit and possibly render it unusable.

Figure 223 Command Mode in Menu 24

```
Menu 24 - System Maintenance

1. System Status
2. System Information and Console Port Speed
3. Log and Trace
4. Diagnostic
5. Backup Configuration
6. Restore Configuration
7. Upload Firmware
8. Command Interpreter Mode
9. Call Control
10. Time and Date Setting
11. Remote Management
```

36.1.1 Command Syntax

The command keywords are in `courier new` font.

Enter the command keywords exactly as shown, do not abbreviate.

The required fields in a command are enclosed in angle brackets <>.

The optional fields in a command are enclosed in square brackets [].

The | symbol means “or”.

For example,

```
sys filter netbios config <type> <on|off>
```

means that you must specify the type of netbios filter and whether to turn it on or off.

36.1.2 Command Usage

A list of commands can be found by typing `help` or `?` at the command prompt. Always type the full command. Type `exit` to return to the SMT main menu when finished.

Figure 224 Valid Commands

```
Copyright (c) 1994 - 2006 ZyXEL Communications Corp.
P-793H> ?
Valid commands are:
sys          exit          device         ether
wan          poe           xdsl           aux
config       ip             ipsec          ppp
bridge       hdap          bm             lan
P-793H>
```

36.2 Call Control Support

The P-793H v2 provides a call control function for budget management. Please note that this menu is only applicable when **Encapsulation** is set to **PPPoE** or **PPPoA** in menu 4 or menu 11.1.

The budget management function allows you to set a limit on the total outgoing call time of the P-793H v2 within certain times. When the total outgoing call time exceeds the limit, the current call will be dropped and any future outgoing calls will be blocked.

Call history chronicles preceding incoming and outgoing calls.

To access the call control menu, select option 9 in menu 24 to go to **Menu 24.9 - System Maintenance - Call Control**, as shown in the next table.

Figure 225 Menu 24.9: System Maintenance - Call Control

Menu 24.9 - System Maintenance - Call Control
1. Budget Management

36.2.1 Budget Management

Menu 24.9.1 shows the budget management statistics for outgoing calls. Enter 1 from **Menu 24.9 - System Maintenance - Call Control** to bring up the following menu. Not all fields are available on all models.

Figure 226 Menu 24.9.1 - Budget Management

Menu 24.9.1 - Budget Management		
Remote Node	Connection Time/Total Budget	Elapsed Time/Total Period
1. MyISP	No Budget	No Budget
2. -----	---	---
3. -----	---	---
4. -----	---	---
5. -----	---	---
6. -----	---	---
7. -----	---	---
8. -----	---	---

The total budget is the time limit on the accumulated time for outgoing calls to a remote node. When this limit is reached, the call will be dropped and further outgoing calls to that remote node will be blocked. After each period, the total budget is reset. The default for the total budget is 0 minutes and the period is 0 hours, meaning no budget control. You can reset the accumulated connection time in this menu by entering the index of a remote node. Enter 0 to update the screen. The budget and the reset period can be configured in menu 11.1 for the remote node.

Table 140 Menu 24.9.1 - Budget Management

FIELD	DESCRIPTION	EXAMPLE
Remote Node	Enter the index number of the remote node you want to reset (just one in this case)	1
Connection Time/ Total Budget	This is the total connection time that has gone by (within the allocated budget that you set in menu 11.1).	5/10 means that 5 minutes out of a total allocation of 10 minutes have lapsed.

Table 140 Menu 24.9.1 - Budget Management (continued)

FIELD	DESCRIPTION	EXAMPLE
Elapsed Time/ Total Period	The period is the time cycle in hours that the allocation budget is reset (see menu 11.1.) The elapsed time is the time used up within this period.	0.5/1 means that 30 minutes out of the 1-hour time period has lapsed.
Enter "0" to update the screen or press [ESC] to return to the previous screen.		

36.3 Time and Date Setting

The P-793H v2's Real Time Chip (RTC) keeps track of the time and date. There is also a software mechanism to set the time manually or get the current time and date from an external server when you turn on your P-793H v2. Menu 24.10 allows you to update the time and date settings of your P-793H v2. The real time is then displayed in the P-793H v2 error logs and firewall logs.

Select menu 24 in the main menu to open **Menu 24 - System Maintenance**, as shown next.

Figure 227 Menu 24: System Maintenance

Menu 24 - System Maintenance
<ol style="list-style-type: none"> 1. System Status 2. System Information and Console Port Speed 3. Log and Trace 4. Diagnostic 5. Backup Configuration 6. Restore Configuration 7. Upload Firmware 8. Command Interpreter Mode 9. Call Control 10. Time and Date Setting 11. Remote Management

Enter 10 to go to **Menu 24.10 - System Maintenance - Time and Date Setting** to update the time and date settings of your P-793H v2 as shown in the following screen.

Figure 228 Menu 24.10: System Maintenance - Time and Date Setting

```

Menu 24.10 - System Maintenance - Time and Date Setting

Time Protocol= None
Time Server Address= N/A

Current Time:                06 : 43 : 17
New Time (hh:mm:ss):        06 : 43 : 00

Current Date:                2000 - 01 - 01
New Date (yyyy-mm-dd):      2000 - 01 - 01

Time Zone= (GMT+0100) Brussels, Copenhagen, Madrid, Paris

Daylight Saving= No
Start Date (mm-nth-week-hr):  Jan. - 1st - Sun.(02) - 00
End Date (mm-nth-week-hr):   Jan. - 1st - Sun.(02) - 00

```

The following table describes the fields in this screen.

Table 141 Menu 24.10: System Maintenance - Time and Date Setting

FIELD	DESCRIPTION
Time Protocol	Enter the time service protocol that your timeserver uses. Not all time servers support all protocols, so you may have to check with your ISP/network administrator or use trial and error to find a protocol that works. The main differences between them are the format. Daytime (RFC 867) format is day/month/year/time zone of the server. Time (RFC-868) format displays a 4-byte integer giving the total number of seconds since 1970/1/1 at 0:0:0. The default, NTP (RFC-1305) , is similar to Time (RFC-868) . Select None to enter the new time and new date manually.
Time Server Address	Enter the IP address or domain name of your timeserver. Check with your ISP/network administrator if you are unsure of this information. The default is tick.stdtime.gov.tw
Current Time	This field displays an updated time only when you reenter this menu.
New Time (hh:mm:ss)	Enter the new time in hour, minute and second format. This field is available when you select None in the Time Protocol field.
Current Date	This field displays an updated date only when you reenter this menu.
New Date (yyyy-mm-dd)	Enter the new date in year, month and day format. This field is available when you select None in the Time Protocol field.
Time Zone	Press [SPACE BAR] and then [ENTER] to set the time difference between your time zone and Greenwich Mean Time (GMT).

Table 141 Menu 24.10: System Maintenance - Time and Date Setting (continued)

FIELD	DESCRIPTION
Daylight Saving	Daylight Saving Time is a period from late spring to early fall when many countries set their clocks ahead of normal local time by one hour to give more daylight time in the evenings. If you use daylight savings time, then choose Yes .
Start Date (mm-nth-week-hr)	<p>Configure the day and time when Daylight Saving Time starts if you selected Yes in the Daylight Saving field. The hr field uses the 24 hour format. Here are a couple of examples:</p> <p>Daylight Saving Time starts in most parts of the United States on the first Sunday of April. Each time zone in the United States starts using Daylight Saving Time at 2 A.M. local time. So in the United States you would select Apr., 1st, Sun. and type 02 in the hr field.</p> <p>Daylight Saving Time starts in the European Union on the last Sunday of March. All of the time zones in the European Union start using Daylight Saving Time at the same moment (1 A.M. GMT or UTC). So in the European Union you would select Mar., Last, Sun. The time you type in the hr field depends on your time zone. In Germany for instance, you would type 02 because Germany's time zone is one hour ahead of GMT or UTC (GMT+1).</p>
End Date (mm-nth-week-hr)	<p>Configure the day and time when Daylight Saving Time ends if you selected Yes in the Daylight Saving field. The hr field uses the 24 hour format. Here are a couple of examples:</p> <p>Daylight Saving Time ends in the United States on the last Sunday of October. Each time zone in the United States stops using Daylight Saving Time at 2 A.M. local time. So in the United States you would select Oct., Last, Sun. and type 02 in the hr field.</p> <p>Daylight Saving Time ends in the European Union on the last Sunday of October. All of the time zones in the European Union stop using Daylight Saving Time at the same moment (1 A.M. GMT or UTC). So in the European Union you would select Oct., Last, Sun. The time you type in the hr field depends on your time zone. In Germany for instance, you would type 02 because Germany's time zone is one hour ahead of GMT or UTC (GMT+1).</p>
Once you have filled in this menu, press [ENTER] at the message "Press ENTER to Confirm or ESC to Cancel" to save your configuration, or press [ESC] to cancel.	

36.4 Remote Management

To disable remote management of a service, select **Disable** in the corresponding **Server Access** field. Enter 11 from menu 24 to bring up **Menu 24.11 - Remote Management Control**.

Figure 229 Menu 24.11 – Remote Management Control

Menu 24.11 - Remote Management Control	
TELNET Server:	
Server Port = 23	Server Access = ALL
Secured Client IP = 0.0.0.0	
FTP Server:	
Server Port = 21	Server Access = ALL
Secured Client IP = 0.0.0.0	
HTTP Server:	
Server Port = 80	Server Access = ALL
Secured Client IP = 0.0.0.0	

The following table describes the fields in this screen.

Table 142 Menu 24.11 – Remote Management Control

FIELD	DESCRIPTION
TELNET Server FTP Server HTTP Server	Each of these read-only labels denotes a service that you may use to remotely manage the P-793H v2.
Server Port	This field shows the port number for the service or protocol. You may change the port number if needed, but you must use the same port number to access the P-793H v2.
Server Access	Select the access interface (if any) by pressing [SPACE BAR], then [ENTER] to choose from: LAN only , WAN only , ALL or Disable .
Secured Client IP	The default 0.0.0.0 allows any client to use this service to remotely manage the P-793H v2. Enter an IP address to restrict access to a client with a matching IP address.
Once you have filled in this menu, press [ENTER] at the message "Press ENTER to Confirm or ESC to Cancel" to save your configuration, or press [ESC] to cancel.	

36.4.1 Remote Management Limitations

Remote management over LAN or WAN will not work when:

- 1 A filter in menu 3.1 (LAN) or in menu 11.5 (WAN) is applied to block a Telnet, FTP or Web service.

- 2 You have disabled that service in menu 24.11.
- 3 The IP address in the **Secure Client IP** field (menu 24.11) does not match the client IP address. If it does not match, the P-793H v2 will disconnect the session immediately.
- 4 There is an SMT console session running.
- 5 There is already another remote management session with an equal or higher priority running. You may only have one remote management session running at one time.
- 6 There is a firewall rule that blocks it.

Schedule Setup

Use this menu to look at and configure the schedule sets in the P-793H v2.

37.1 Schedule Set Overview

Call scheduling (applicable for PPPoE encapsulation only) allows the P-793H v2 to manage a remote node and dictate when a remote node should be called and for how long. This feature is similar to the scheduler that lets you specify a time period to record a television program in a VCR or TiVo.

37.2 Schedule Setup

This menu is only applicable if your Internet connection uses PPPoE encapsulation. Use this menu to look at the schedule sets in the P-793H v2. To open this menu, enter 26 in the main menu.

Figure 230 Menu 26: Schedule Setup

```

Menu 26 - Schedule Setup

Schedule          Schedule
Set #            Name          Set #            Name
-----          -
1                _____  7                _____
2                _____  8                _____
3                _____  9                _____
4                _____  10               _____
5                _____  11               _____
6                _____  12               _____

Enter Schedule Set Number to Configure= 0

Edit Name= N/A

```

The following table describes the labels in this menu.

Table 143 Menu 26: Schedule Setup

FIELD	DESCRIPTION
1-12	This field shows the beginning of the name of each schedule set. Lower numbered sets take precedence over higher numbered sets. This avoids scheduling conflicts. For example, if sets 1, 2, 3 and 4 in are applied in the remote node, then set 1 takes precedence over set 2, 3 and 4.
Enter Schedule Set Number to Configure	If you want to configure a schedule set, enter the number of the static route in this field, enter the name in the Edit Name field, and press [ENTER]. Menu 26.1 appears. If you want to delete a schedule set, enter the number of the static route in this field, leave the name blank in the Edit Name field, and press [ENTER].
Edit Name	Enter the name of the schedule set you want to configure, or leave this field blank to delete the specified schedule set.

37.3 Schedule Set Setup

This menu is only applicable if your Internet connection uses PPPoE encapsulation. Use this menu to configure the schedule sets in the P-793H v2. To open this menu, enter the number of the schedule set in the **Enter Schedule Set Number to Configure** field, enter the name of the schedule set in the **Edit Name** field, and press [ENTER] in menu 26.

Figure 231 Menu 26.1: Schedule Set Setup

Menu 26.1 Schedule Set Setup
<pre> Active= Yes Start Date(yyyy-mm-dd)= 2000 - 01 - 01 How Often= Once Once: Date(yyyy-mm-dd)= 2000 - 01 - 01 Weekdays: Sunday= N/A Monday= N/A Tuesday= N/A Wednesday= N/A Thursday= N/A Friday= N/A Saturday= N/A Start Time(hh:mm)= 00 : 00 Duration(hh:mm)= 00 : 00 Action= Forced On </pre>

The following table describes the labels in this menu.

Table 144 Menu 26.1: Schedule Set Setup

FIELD	DESCRIPTION
Active	Press [SPACE BAR] to select Yes or No . Choose Yes and press [ENTER] to activate the schedule set.
Start Date	Should this schedule set recur weekly or be used just once only? Press the [SPACE BAR] and then [ENTER] to select Once or Weekly . Both these options are mutually exclusive. If Once is selected, then all weekday settings are N/A . When Once is selected, the schedule rule deletes automatically after the scheduled time elapses.
How Often	Enter the start date when you wish the set to take effect in year - month-date format. Valid dates are from the present to 2036-February-5.
Once	
Date	If you selected Once in the How Often field above, then enter the date the set should activate here in year-month-date format.
Weekdays	If you selected Weekly in the How Often field above, then select the day(s) when the set should activate (and recur) by going to that day(s) and pressing [SPACE BAR] to select Yes , then press [ENTER].
Start Time	Enter the start time when you wish the schedule set to take effect in hour-minute format.
Duration	Enter the maximum length of time this connection is allowed in hour-minute format.
Action	<p>Forced On means that the connection is maintained whether or not there is a demand call on the line and will persist for the time period specified in the Duration field.</p> <p>Forced Down means that the connection is blocked whether or not there is a demand call on the line.</p> <p>Enable Dial-On-Demand means that this schedule permits a demand call on the line. Disable Dial-On-Demand means that this schedule prevents a demand call on the line.</p>

Troubleshooting

This chapter offers some suggestions to solve problems you might encounter. The potential problems are divided into the following categories.

- [Power, Hardware Connections, and LEDs](#)
- [P-793H v2 Access and Login](#)
- [Internet Access](#)
- [Network Connections](#)

38.1 Power, Hardware Connections, and LEDs

The P-793H v2 does not turn on. None of the LEDs turn on.

- 1 Make sure the P-793H v2 is turned on.
- 2 Make sure you are using the power adaptor or cord included with the P-793H v2.
- 3 Make sure the power adaptor or cord is connected to the P-793H v2 and plugged in to an appropriate power source. Make sure the power source is turned on.
- 4 Turn the P-793H v2 off and on.
- 5 If the problem continues, contact the vendor.

One of the LEDs does not behave as expected.

- 1 Make sure you understand the normal behavior of the LED. See [Section 1.4 on page 40](#).
- 2 Check the hardware connections.

- 3 Inspect your cables for damage. Contact the vendor to replace any damaged cables.
- 4 Turn the P-793H v2 off and on.
- 5 If the problem continues, contact the vendor.

38.2 P-793H v2 Access and Login

I forgot the IP address for the P-793H v2.

- 1 The default IP address is **192.168.1.1**.
- 2 If you changed the IP address and have forgotten it, you might get the IP address of the P-793H v2 by looking up the IP address of the default gateway for your computer. To do this in most Windows computers, click **Start > Run**, enter **cmd**, and then enter **ipconfig**. The IP address of the **Default Gateway** might be the IP address of the P-793H v2 (it depends on the network), so enter this IP address in your Internet browser.
- 3 If this does not work, you have to reset the device to its factory defaults. See [Section 1.5 on page 41](#).

I forgot the password.

- 1 The default admin password is **1234**, and the default user password is **user**.
- 2 If this does not work, you have to reset the device to its factory defaults. See [Section 1.5 on page 41](#).

I cannot see or access the **Login** screen in the web configurator.

- 1 Make sure you are using the correct IP address.
 - The default IP address is **192.168.1.1**.
 - If you changed the IP address ([Section 7.2 on page 103](#)), use the new IP address.

- If you changed the IP address and have forgotten it, see the troubleshooting suggestions for [I forgot the IP address for the P-793H v2](#).
- 2 Check the hardware connections, and make sure the LEDs are behaving as expected. See the Quick Start Guide.
 - 3 Make sure your Internet browser does not block pop-up windows and has JavaScripts and Java enabled. See [Appendix D on page 453](#).
 - If there is a DHCP server on your network, make sure your computer is using a dynamic IP address. See [Appendix C on page 429](#). Your P-793H v2 is a DHCP server by default.
 - If there is no DHCP server on your network, make sure your computer's IP address is in the same subnet as the P-793H v2. See [Appendix C on page 429](#).
 - 4 Reset the device to its factory defaults, and try to access the P-793H v2 with the default IP address. See [Section 1.5 on page 41](#).
 - 5 If the problem continues, contact the network administrator or vendor, or try one of the advanced suggestions.

Advanced Suggestions

- Try to access the P-793H v2 using another service, such as Telnet. If you can access the P-793H v2, check the remote management settings and firewall rules to find out why the P-793H v2 does not respond to HTTP.
- If your computer is connected to the **WAN** port, use a computer that is connected to a **ETHERNET** port.

I can see the **Login** screen, but I cannot log in to the P-793H v2.

- 1 Make sure you have entered the password correctly. The default admin password is **1234**, and the default user password is **user**. The field is case-sensitive, so make sure [Caps Lock] is not on.
- 2 You cannot log in to the web configurator while someone is using Telnet to access the P-793H v2. Log out of the P-793H v2 in the other session, or ask the person who is logged in to log out.
- 3 Turn the P-793H v2 off and on.
- 4 If this does not work, you have to reset the device to its factory defaults. See [Section 1.5 on page 41](#).

I cannot Telnet to the P-793H v2.

See the troubleshooting suggestions for [I cannot see or access the Login screen in the web configurator](#). Ignore the suggestions about your browser.

I cannot use FTP to upload / download the configuration file. / I cannot use FTP to upload new firmware.

See the troubleshooting suggestions for [I cannot see or access the Login screen in the web configurator](#). Ignore the suggestions about your browser.

38.3 Internet Access

I cannot access the Internet.

- 1 Check the hardware connections, and make sure the LEDs are behaving as expected. See the Quick Start Guide and [Section 1.4 on page 40](#).
- 2 Make sure you entered your ISP account information correctly in the wizard. These fields are case-sensitive, so make sure [Caps Lock] is not on.
- 3 Disconnect all the cables from your device, and follow the directions in the Quick Start Guide again.
- 4 If the problem continues, contact your ISP.

I cannot access the Internet anymore. I had access to the Internet (with the P-793H v2), but my Internet connection is not available anymore.

- 1 Check the hardware connections, and make sure the LEDs are behaving as expected. See the Quick Start Guide and [Section 1.4 on page 40](#).
- 2 Turn the P-793H v2 off and on.

- 3 If the problem continues, contact your ISP.

The Internet connection is slow or intermittent.

- 1 There might be a lot of traffic on the network. Look at the LEDs, and check [Section 1.4 on page 40](#). If the P-793H v2 is sending or receiving a lot of information, try closing some programs that use the Internet, especially peer-to-peer applications.
- 2 Turn the P-793H v2 off and on.
- 3 If the problem continues, contact the network administrator or vendor, or try one of the advanced suggestions.

Advanced Suggestions

- Check the settings for QoS. If it is disabled, you might consider activating it. If it is enabled, you might consider raising or lowering the priority for some applications.

38.4 Network Connections

My network cannot be connected. How can I check the Internet connection status?

- 1 Check the LEDs on the P-793H v2 for the following situations:
 - If the **DSL** LEDs are off, there is no DSL connection. Check if your cables are connected properly to the P-793H v2.
 - If the **DSL** LEDs are blinking fast, the P-793H v2 is initializing the DSL line. If they keeps blinking for a long time, please reboot the device.

Note: For Internet access setup or point-to-point connections, the DSL1 and DSL2 LEDs indicate the status of a single connection (act as one LED). For point-to-point connections, the DSL1 and DSL2 LEDs indicate the status of connection 1 and connection 2 respectively.

- If the **INTERNET** LED lights red, the P-793H v2 attempted to become IP connected but failed. The reason might be no DHCP response, no PPPoE response, PPPoE authentication failed, or no IP address from IPCP. Please check if you have entered the correct ISP account and password when setting up the Internet connection. If the status is the same, reboot the device. If the problem remains, please contact your vendor or customer support.
- 2** Excess errors may occur if the quality of your line is poor. If you hear noise on the line while making a telephone call, you should ask your local telecommunications office to check the lines in your house or apartment building and the line from your residence to your DSL service provider.

Product Specifications

Table 145 Device

Default IP Address	192.168.1.1
Default Subnet Mask	255.255.255.0 (24 bits)
Default Password	user: "user" administrator: "1234"
DHCP Pool	192.168.1.33 to 192.168.1.64
Dimensions (W x D x H)	178 x 125 x 31 mm
Power Specification	12V AC 1A
G.SHDSL Port	RJ-14 interface Data Rate: 192 Kbps - 5696 Kbps, 192-11392 kbps (4-wire mode) Line Code: TC-PAM modulation Line Impedance: 135 W Connection Loops: two pairs (4-wire)
Operation Temperature	0° C ~ 40° C
Storage Temperature	-20° ~ 60° C
Operation Humidity	20% ~ 90% RH
Storage Humidity	20% ~ 95% RH

Table 146 Firmware

Routing/Bridge Support	<p>IP (RFC 791) routing is supported.</p> <p>TCP, UDP, ICMP, IGMP v1 and v2, ARP, RIP v1, RIP v2</p> <p>Transparent bridging (IEEE 802.1D)</p> <p>PPP BCP (RFC 3185) support</p>
G.SHDSL	<p>Connection with symmetric speed up to 11.4 Mbps in either ATM mode and EFM mode</p> <p>Support ITU-T G991.2 / G.994.1 standards</p> <p>Support ITU-T G.998.3 (G.bond)</p> <p>Support IPOE</p> <p>TC-PAM line modulation</p> <p>Configurable as either server or client mode</p> <p>OAM IEEE 802.3 chapter 57 compliant</p> <p>IEEE 802.3 2BASE-TL (aka 802.3ah) compliant</p> <p>Rate negotiating / Manually rate adaptation configuration</p> <p>2-wire and 4-wire rate auto detect in either ATM mode and EFM mode.</p> <p>Data Rate Selections: From 192 kbps to 5700 kbps (2-wire mode)</p> <p>Data Rate Selections: From 192 kbps to 11400 kbps (4-wire mode)</p> <p>Support Bonding based on EFM and ATM</p>
ATM Support	<p>Multiple protocols over AAL5 (RFC1483)</p> <p>PPP over ATM (RFC 2364)</p> <p>ATM AAL5 supported</p> <p>Support 8 PVCs</p> <p>ATM Forum UNI3.0/4.0 PVC</p> <p>OAM F4/F5 Loopback, RDI, AIS</p> <p>UBR CBR, and nrt-VBR traffic shaping</p>
EFM Support	<p>EFM mode compliant to IEEE 802.3, G.998.3 bonding</p> <p>PPP over Ethernet (RFC2516)</p> <p>VLAN base QoS (802.1P/Q)</p>

Table 146 Firmware (continued)

Internet Access Sharing	NAT (includes multi-to-multi NAT) / SUA, 2048 NAT sessions Port restricted cone NAT SIP ALG pass-through NAT server (Port forwarding) Multi-NAT Dynamic DNS (www.dyndns.org) DHCP server/client/relay
Security	User Authentication (PAP, CHAP) with PPP (RFC 1334, RFC 1994) Microsoft CHAP Stateful packet inspection firewall Content filter Prevent Denial of service Access control of service Real-time attack alert and log
Network Management	Web-based Configuration Command-line interface Password-protected Telnet support SNMP MIB I /MIB II support TFTP & FTP firmware upgrade and configuration backup TR-069(HTTPS)
VPN	IPSec VPN support 10 VPN tunnels IKE/ Manual Key DES/3DES/AES Encryption (HW DES) MD5/ SHA1 Authentication FQDN NETBIOS pass-through for IPSec IPSec VPN keep-alive IPSec NAT Traversal

Table 146 Firmware (continued)

Diagnostics Capabilities (for the following circuitry)	FLASH memory SDSL circuitry RAM LAN port
Others	DNS Proxy UNIX syslog

Table 147 Firmware Features

FEATURE	DESCRIPTION
Firmware Upgrade	Download new firmware (when available) from the ZyXEL web site and use the web configurator, an FTP or a TFTP tool to put it on the P-793H v2. Note: Only upload firmware for your specific model!
Configuration Backup & Restoration	Make a copy of the P-793H v2's configuration. You can put it back on the P-793H v2 later if you decide to revert back to an earlier configuration.
Network Address Translation (NAT)	Each computer on your network must have its own unique IP address. Use NAT to convert your public IP address(es) to multiple private IP addresses for the computers on your network.
Port Forwarding	If you have a server (mail or web server for example) on your network, you can use this feature to let people access it from the Internet.
DHCP (Dynamic Host Configuration Protocol)	Use this feature to have the P-793H v2 assign IP addresses, an IP default gateway and DNS servers to computers on your network.
Dynamic DNS Support	With Dynamic DNS (Domain Name System) support, you can use a fixed URL, www.zyxel.com for example, with a dynamic IP address. You must register for this service with a Dynamic DNS service provider.
IP Multicast	IP multicast is used to send traffic to a specific group of computers. The P-793H v2 supports versions 1 and 2 of IGMP (Internet Group Management Protocol) used to join multicast groups (see RFC 2236).
IP Alias	IP alias allows you to subdivide a physical network into logical networks over the same Ethernet interface with the P-793H v2 itself as the gateway for each subnet.
Time and Date	Get the current time and date from an external server when you turn on your P-793H v2. You can also set the time manually. These dates and times are then used in logs.
Logging and Tracing	Use packet tracing and logs for troubleshooting. You can send logs from the P-793H v2 to an external syslog server.
PPPoE	PPPoE mimics a dial-up Internet access connection.
PPTP Encapsulation	Point-to-Point Tunneling Protocol (PPTP) enables secure transfer of data through a Virtual Private Network (VPN). The P-793H v2 supports one PPTP connection at a time.
Universal Plug and Play (UPnP)	A UPnP-enabled device can dynamically join a network, obtain an IP address and convey its capabilities to other devices on the network.
Firewall	You can configure firewall on the ZyXEL Device for secure Internet access. When the firewall is on, by default, all incoming traffic from the Internet to your network is blocked unless it is initiated from your network. This means that probes from the outside to your network are not allowed, but you can safely browse the Internet and download files for example.

Table 147 Firmware Features

FEATURE	DESCRIPTION
Content Filter	The P-793H v2 blocks or allows access to web sites that you specify and blocks access to web sites with URLs that contain keywords that you specify. You can define time periods and days during which content filtering is enabled. You can also include or exclude particular computers on your network from content filtering.
Bandwidth Management	You can efficiently manage traffic on your network by reserving bandwidth and giving priority to certain types of traffic and/or to particular computers.
Remote Management	This allows you to decide whether a service (HTTP or FTP traffic for example) from a computer on a network (LAN or WAN for example) can access the P-793H v2.

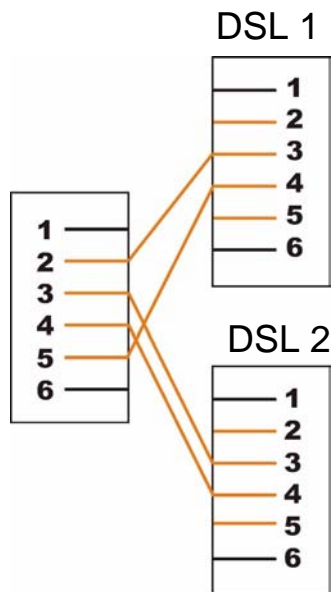
Figure 232 Y-Cable Configuration

Wall-mounting Instructions

Do the following to hang your P-793H v2 on a wall.

Note: See the product specifications appendix for the size of screws to use and how far apart to place them.

- 1 Locate a high position on a wall that is free of obstructions. Use a sturdy wall.
- 2 Drill two holes for the screws. Make sure the distance between the centers of the holes matches what is listed in the product specifications appendix.

Note: Be careful to avoid damaging pipes or cables located inside the wall when drilling holes for the screws.

- 3 Do not screw the screws all the way into the wall. Leave a small gap of about 0.5 cm between the heads of the screws and the wall.
- 4 Make sure the screws are snugly fastened to the wall. They need to hold the weight of the P-793H v2 with the connection cables.
- 5 Align the holes on the back of the P-793H v2 with the screws on the wall. Hang the P-793H v2 on the screws.

Figure 233 Wall-mounting Example

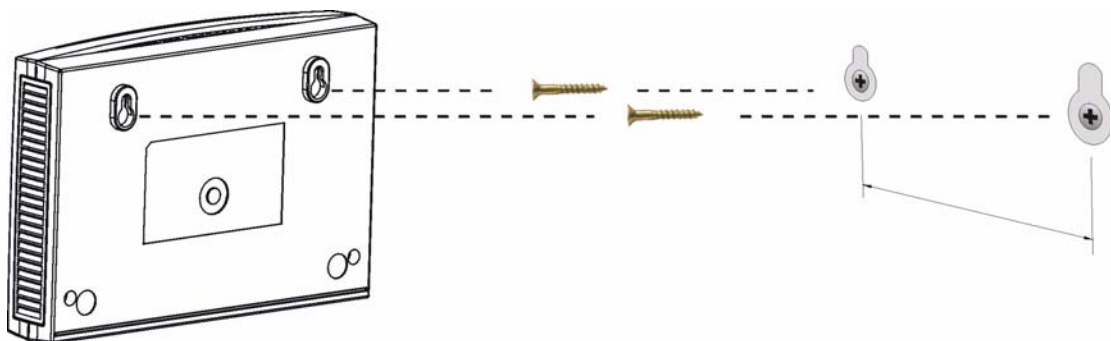

Setting up Your Computer's IP Address

All computers must have a 10M or 100M Ethernet adapter card and TCP/IP installed.

Windows 95/98/Me/NT/2000/XP/Vista, Macintosh OS 7 and later operating systems and all versions of UNIX/LINUX include the software components you need to install and use TCP/IP on your computer. Windows 3.1 requires the purchase of a third-party TCP/IP application package.

TCP/IP should already be installed on computers using Windows NT/2000/XP, Macintosh OS 7 and later operating systems.

After the appropriate TCP/IP components are installed, configure the TCP/IP settings in order to "communicate" with your network.

If you manually assign IP information instead of using dynamic assignment, make sure that your computers have IP addresses that place them in the same subnet as the P-793H v2's LAN port.

Windows 95/98/Me

Click **Start, Settings, Control Panel** and double-click the **Network** icon to open the **Network** window.

Figure 234 WIndows 95/98/Me: Network: Configuration

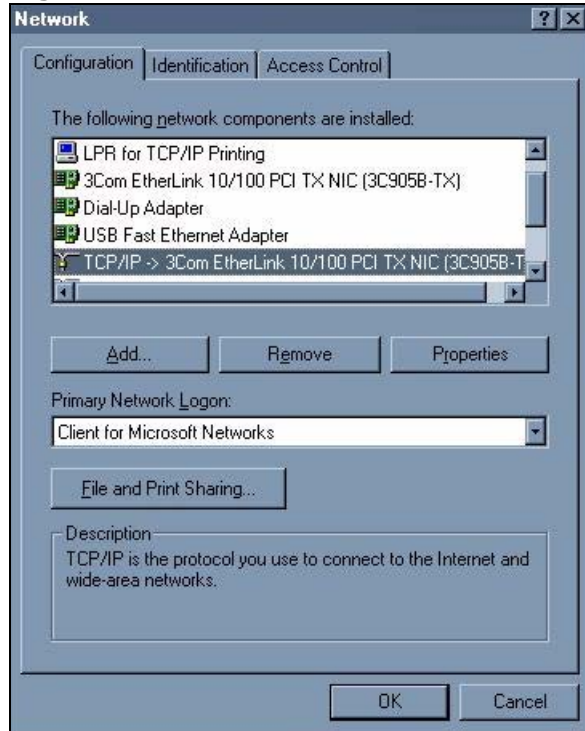

Installing Components

The **Network** window **Configuration** tab displays a list of installed components. You need a network adapter, the TCP/IP protocol and Client for Microsoft Networks.

If you need the adapter:

- 1 In the **Network** window, click **Add**.
- 2 Select **Adapter** and then click **Add**.
- 3 Select the manufacturer and model of your network adapter and then click **OK**.

If you need TCP/IP:

- 1 In the **Network** window, click **Add**.
- 2 Select **Protocol** and then click **Add**.

- 3 Select **Microsoft** from the list of **manufacturers**.
- 4 Select **TCP/IP** from the list of network protocols and then click **OK**.

If you need Client for Microsoft Networks:

- 1 Click **Add**.
- 2 Select **Client** and then click **Add**.
- 3 Select **Microsoft** from the list of manufacturers.
- 4 Select **Client for Microsoft Networks** from the list of network clients and then click **OK**.
- 5 Restart your computer so the changes you made take effect.

Configuring

- 1 In the **Network** window **Configuration** tab, select your network adapter's TCP/IP entry and click **Properties**
- 2 Click the **IP Address** tab.
 - If your IP address is dynamic, select **Obtain an IP address automatically**.
 - If you have a static IP address, select **Specify an IP address** and type your information into the **IP Address** and **Subnet Mask** fields.

Figure 235 Windows 95/98/Me: TCP/IP Properties: IP Address

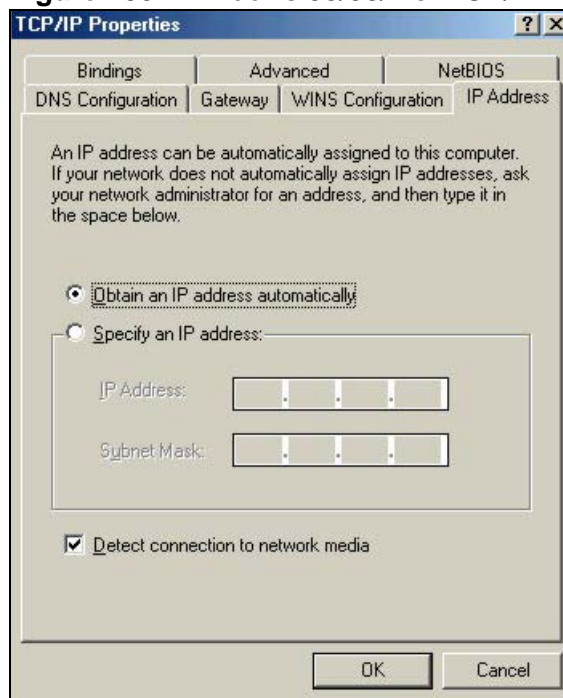

- 3 Click the **DNS** Configuration tab.
 - If you do not know your DNS information, select **Disable DNS**.
 - If you know your DNS information, select **Enable DNS** and type the information in the fields below (you may not need to fill them all in).

Figure 236 Windows 95/98/Me: TCP/IP Properties: DNS Configuration

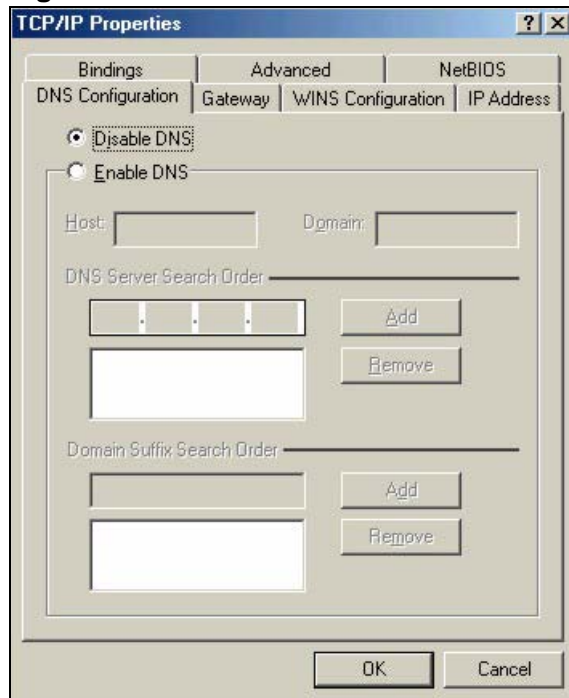

- 4 Click the **Gateway** tab.
 - If you do not know your gateway's IP address, remove previously installed gateways.
 - If you have a gateway IP address, type it in the **New gateway field** and click **Add**.
- 5 Click **OK** to save and close the **TCP/IP Properties** window.
- 6 Click **OK** to close the **Network** window. Insert the Windows CD if prompted.
- 7 Turn on your P-793H v2 and restart your computer when prompted.

Verifying Settings

- 1 Click **Start** and then **Run**.
- 2 In the **Run** window, type "winipcfg" and then click **OK** to open the **IP Configuration** window.
- 3 Select your network adapter. You should see your computer's IP address, subnet mask and default gateway.

Windows 2000/NT/XP

The following example figures use the default Windows XP GUI theme.

- 1 Click **start** (**Start** in Windows 2000/NT), **Settings**, **Control Panel**.

Figure 237 Windows XP: Start Menu

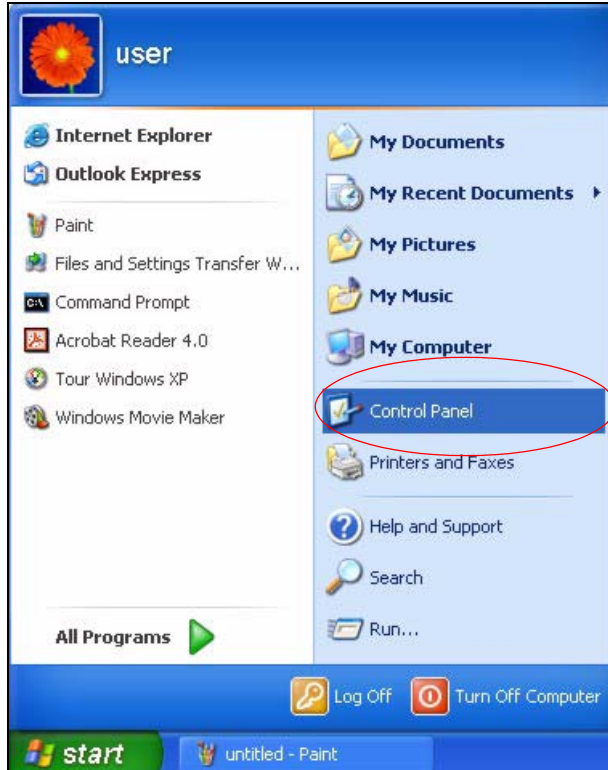

- 2 In the **Control Panel**, double-click **Network Connections** (**Network and Dial-up Connections** in Windows 2000/NT).

Figure 238 Windows XP: Control Panel



- 3 Right-click **Local Area Connection** and then click **Properties**.

Figure 239 Windows XP: Control Panel: Network Connections: Properties

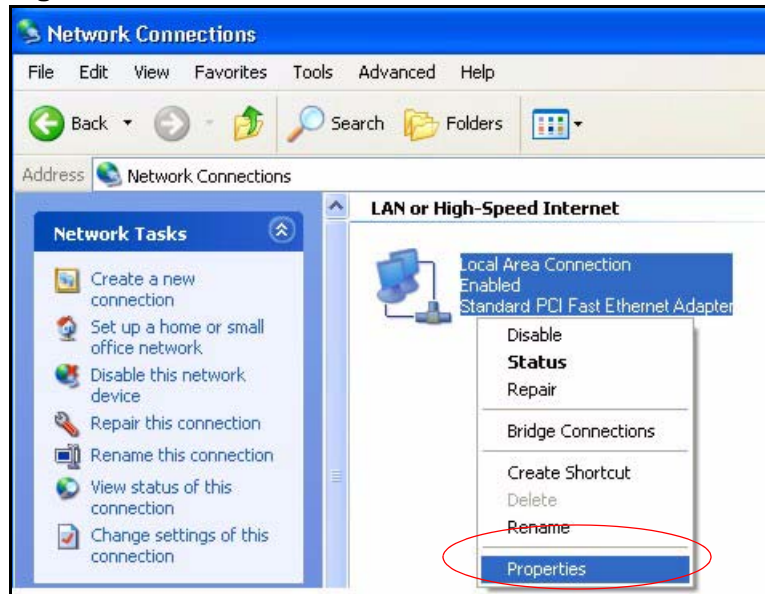

- 4 Select **Internet Protocol (TCP/IP)** (under the **General** tab in Win XP) and then click **Properties**.

Figure 240 Windows XP: Local Area Connection Properties

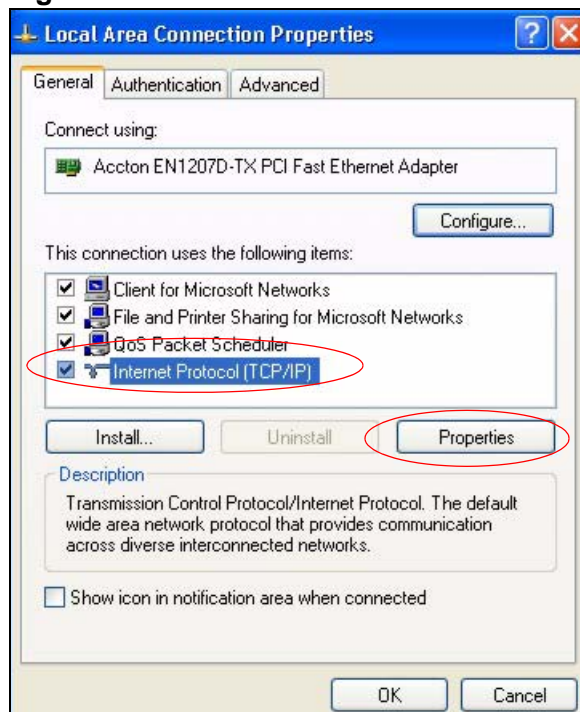

- 5 The **Internet Protocol TCP/IP Properties** window opens (the **General** tab in Windows XP).

- If you have a dynamic IP address click **Obtain an IP address automatically**.
- If you have a static IP address click **Use the following IP Address** and fill in the **IP address**, **Subnet mask**, and **Default gateway** fields.
- Click **Advanced**.

Figure 241 Windows XP: Internet Protocol (TCP/IP) Properties

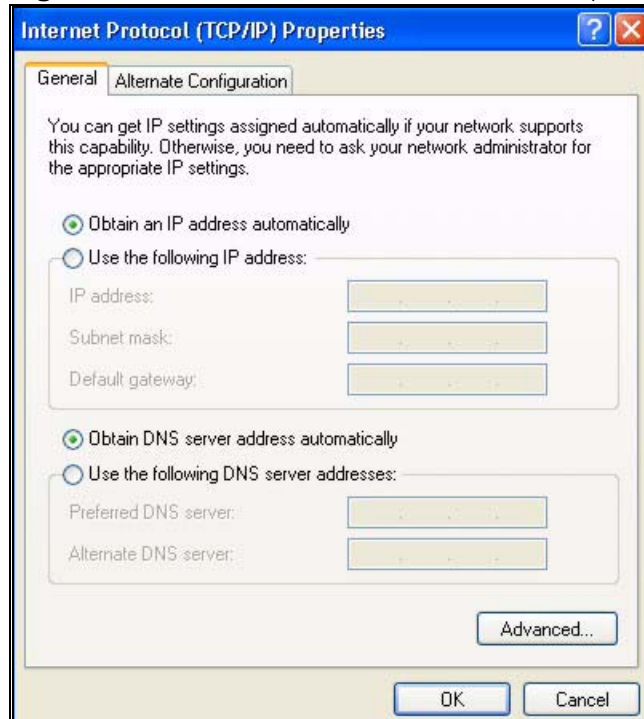

- 6 If you do not know your gateway's IP address, remove any previously installed gateways in the **IP Settings** tab and click **OK**.

Do one or more of the following if you want to configure additional IP addresses:

- In the **IP Settings** tab, in IP addresses, click **Add**.
- In **TCP/IP Address**, type an IP address in **IP address** and a subnet mask in **Subnet mask**, and then click **Add**.
- Repeat the above two steps for each IP address you want to add.
- Configure additional default gateways in the **IP Settings** tab by clicking **Add** in **Default gateways**.
- In **TCP/IP Gateway Address**, type the IP address of the default gateway in **Gateway**. To manually configure a default metric (the number of transmission hops), clear the **Automatic metric** check box and type a metric in **Metric**.
- Click **Add**.
- Repeat the previous three steps for each default gateway you want to add.

- Click **OK** when finished.

Figure 242 Windows XP: Advanced TCP/IP Properties

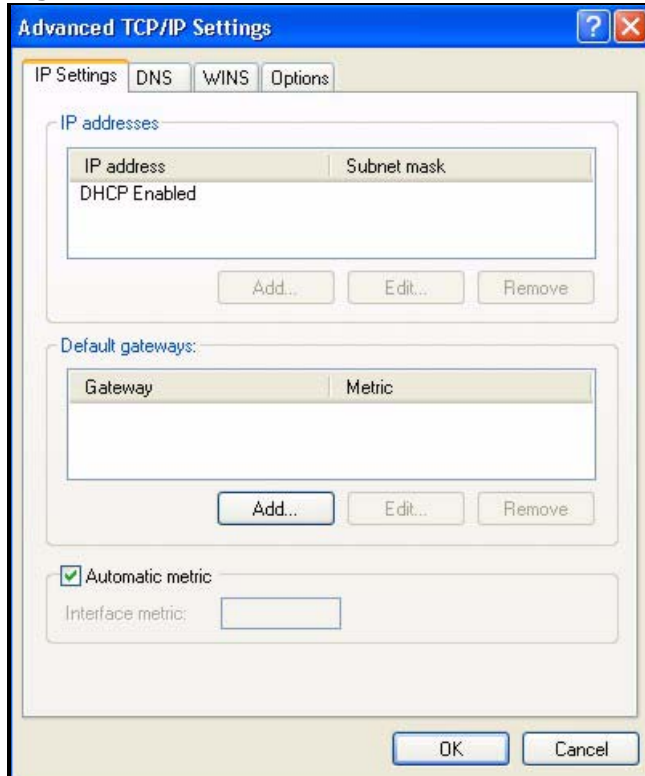

7 In the **Internet Protocol TCP/IP Properties** window (the **General** tab in Windows XP):

- Click **Obtain DNS server address automatically** if you do not know your DNS server IP address(es).
- If you know your DNS server IP address(es), click **Use the following DNS server addresses**, and type them in the **Preferred DNS server** and **Alternate DNS server** fields.

If you have previously configured DNS servers, click **Advanced** and then the **DNS** tab to order them.

Figure 243 Windows XP: Internet Protocol (TCP/IP) Properties

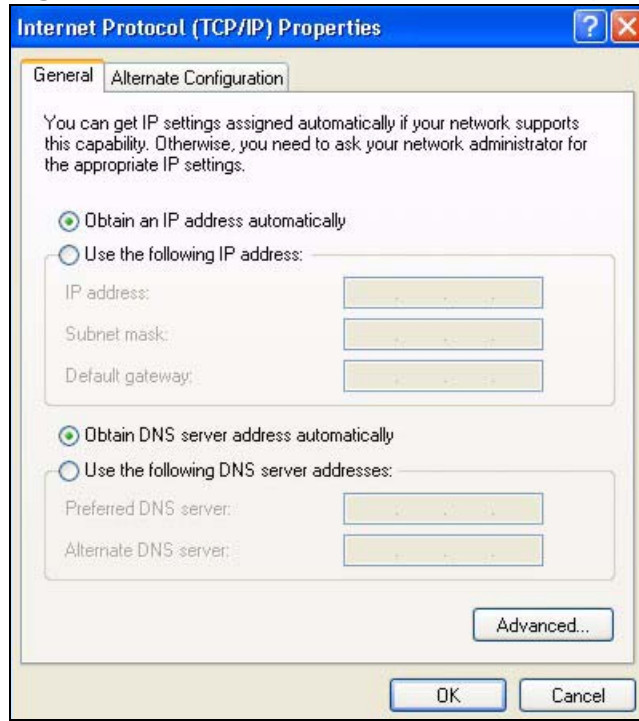

- 8 Click **OK** to close the **Internet Protocol (TCP/IP) Properties** window.
- 9 Click **Close** (**OK** in Windows 2000/NT) to close the **Local Area Connection Properties** window.
- 10 Close the **Network Connections** window (**Network and Dial-up Connections** in Windows 2000/NT).
- 11 Turn on your P-793H v2 and restart your computer (if prompted).

Verifying Settings

- 1 Click **Start**, **All Programs**, **Accessories** and then **Command Prompt**.
- 2 In the **Command Prompt** window, type "ipconfig" and then press [ENTER]. You can also open **Network Connections**, right-click a network connection, click **Status** and then click the **Support** tab.

Windows Vista

This section shows screens from Windows Vista Enterprise Version 6.0.

- 1 Click the **Start** icon, **Control Panel**.

Figure 244 Windows Vista: Start Menu



- 2 In the **Control Panel**, double-click **Network and Internet**.

Figure 245 Windows Vista: Control Panel

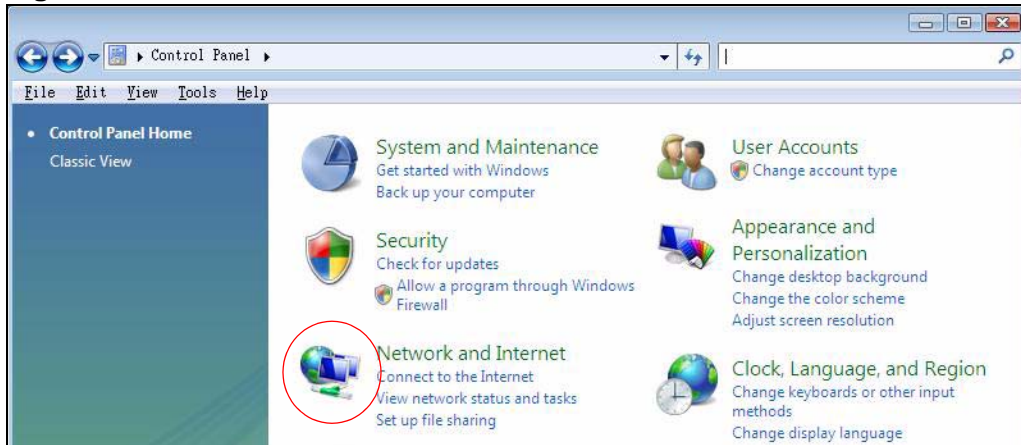

- 3 Click **Network and Sharing Center**.

Figure 246 Windows Vista: Network And Internet

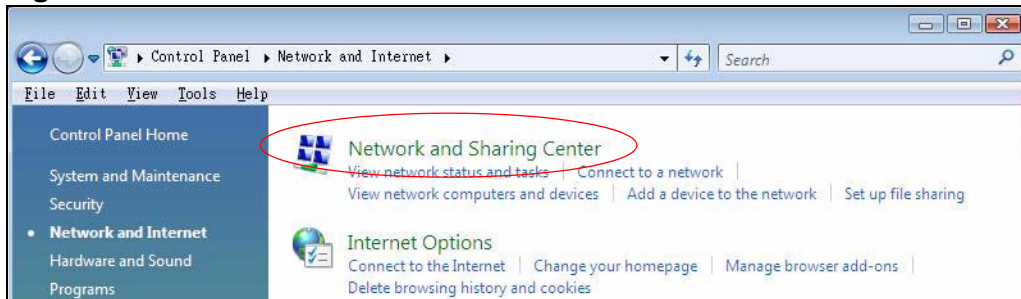

4 Click **Manage network connections**.

Figure 247 Windows Vista: Network and Sharing Center

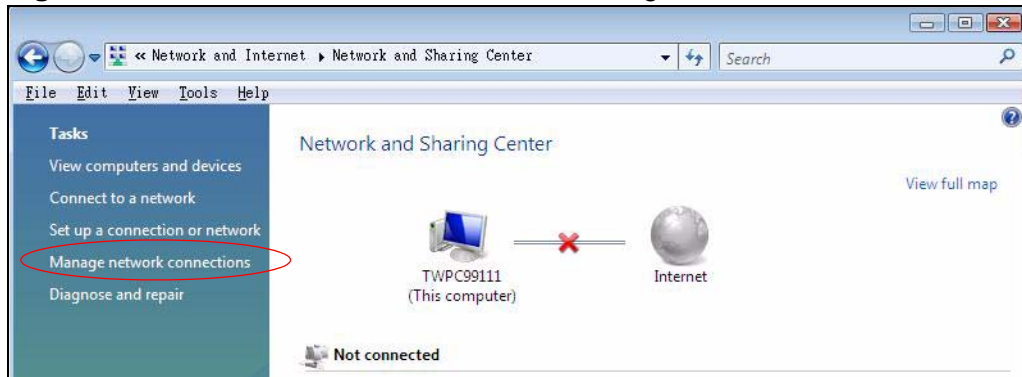

5 Right-click **Local Area Connection** and then click **Properties**.

Note: During this procedure, click **Continue** whenever Windows displays a screen saying that it needs your permission to continue.

Figure 248 Windows Vista: Network and Sharing Center

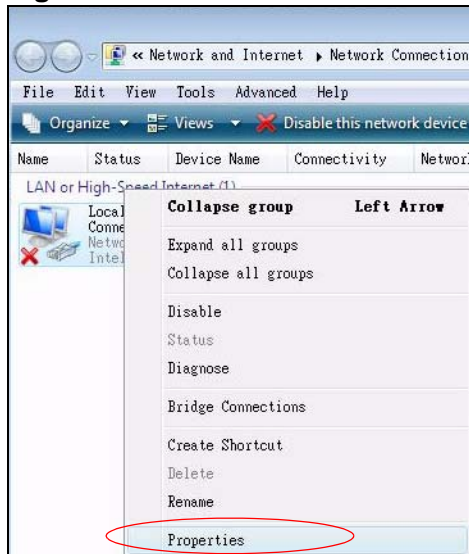

- 6 Select **Internet Protocol Version 4 (TCP/IPv4)** and click **Properties**.

Figure 249 Windows Vista: Local Area Connection Properties

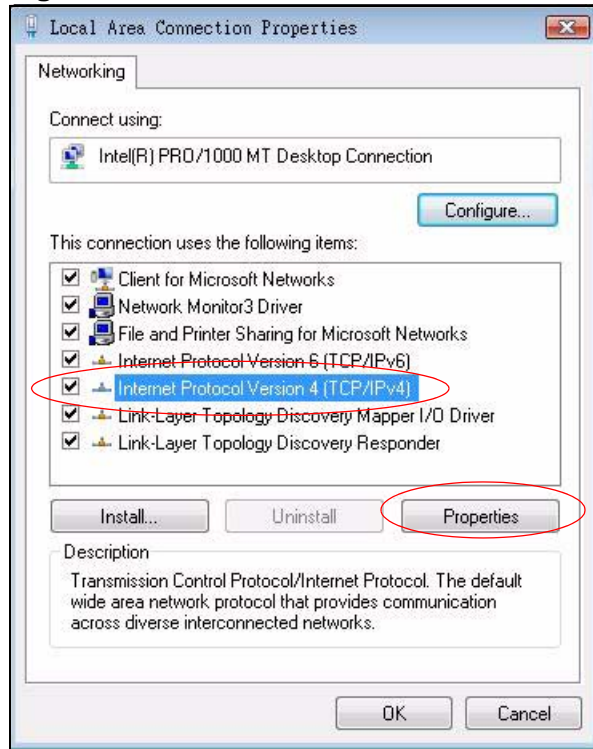

- 7 The **Internet Protocol Version 4 (TCP/IPv4) Properties** window opens (the **General** tab).

- If you have a dynamic IP address click **Obtain an IP address automatically**.
- If you have a static IP address click **Use the following IP address** and fill in the **IP address**, **Subnet mask**, and **Default gateway** fields.

- Click **Advanced**.

Figure 250 Windows Vista: Internet Protocol Version 4 (TCP/IPv4) Properties

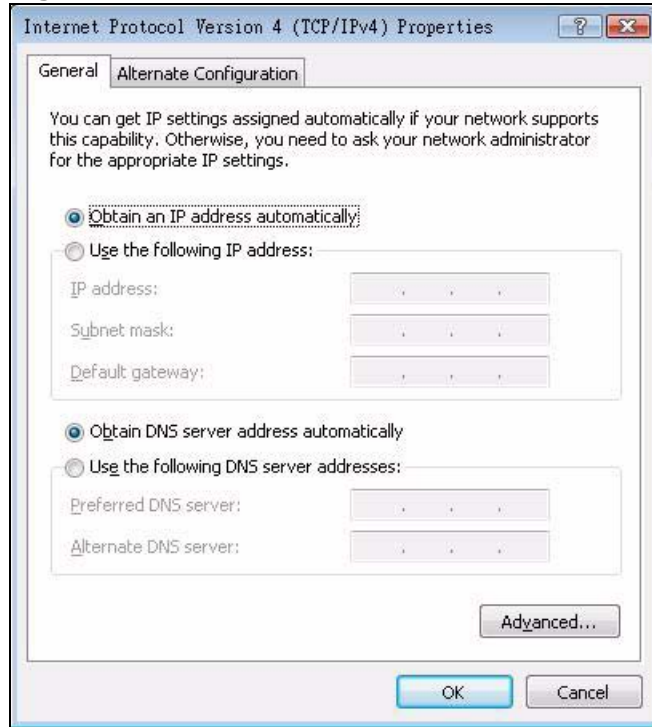

- 8 If you do not know your gateway's IP address, remove any previously installed gateways in the **IP Settings** tab and click **OK**.

Do one or more of the following if you want to configure additional IP addresses:

- In the **IP Settings** tab, in IP addresses, click **Add**.
- In **TCP/IP Address**, type an IP address in **IP address** and a subnet mask in **Subnet mask**, and then click **Add**.
- Repeat the above two steps for each IP address you want to add.
- Configure additional default gateways in the **IP Settings** tab by clicking **Add** in **Default gateways**.
- In **TCP/IP Gateway Address**, type the IP address of the default gateway in **Gateway**. To manually configure a default metric (the number of transmission hops), clear the **Automatic metric** check box and type a metric in **Metric**.
- Click **Add**.
- Repeat the previous three steps for each default gateway you want to add.

- Click **OK** when finished.

Figure 251 Windows Vista: Advanced TCP/IP Properties

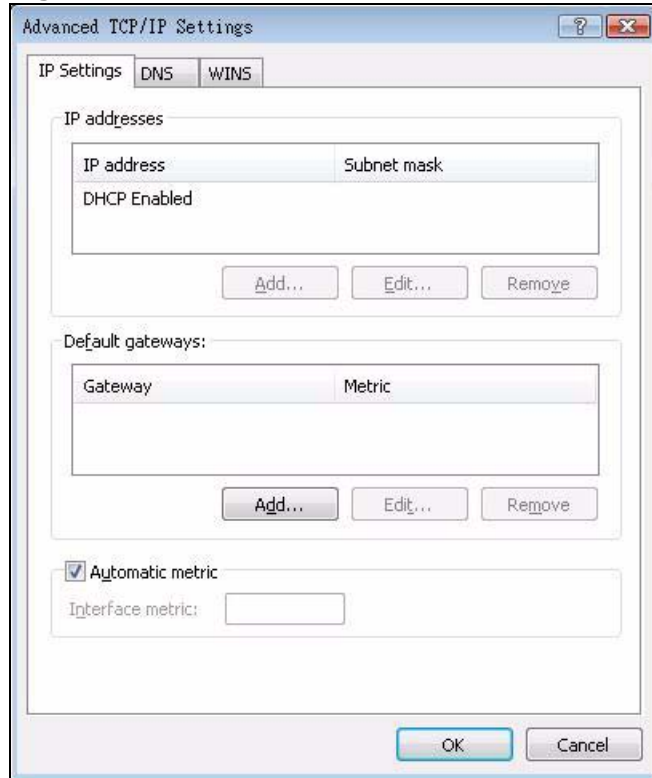

- 9 In the **Internet Protocol Version 4 (TCP/IPv4) Properties** window, (the **General** tab):
- Click **Obtain DNS server address automatically** if you do not know your DNS server IP address(es).
 - If you know your DNS server IP address(es), click **Use the following DNS server addresses**, and type them in the **Preferred DNS server** and **Alternate DNS server** fields.

If you have previously configured DNS servers, click **Advanced** and then the **DNS** tab to order them.

Figure 252 Windows Vista: Internet Protocol Version 4 (TCP/IPv4) Properties

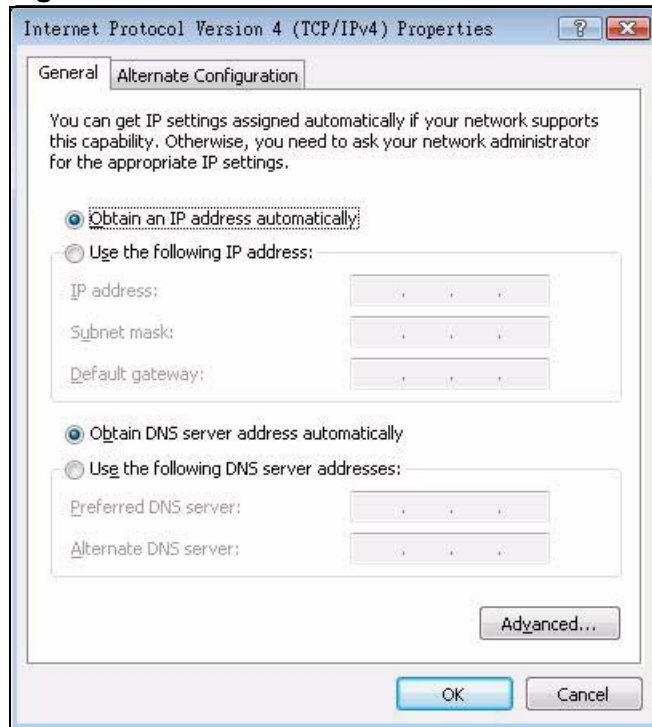

- 10 Click **OK** to close the **Internet Protocol Version 4 (TCP/IPv4) Properties** window.
- 11 Click **Close** to close the **Local Area Connection Properties** window.
- 12 Close the **Network Connections** window.
- 13 Turn on your P-793H v2 and restart your computer (if prompted).

Verifying Settings

- 1 Click **Start**, **All Programs**, **Accessories** and then **Command Prompt**.
- 2 In the **Command Prompt** window, type "ipconfig" and then press [ENTER]. You can also open **Network Connections**, right-click a network connection, click **Status** and then click the **Support** tab.

Macintosh OS 8/9

- 1 Click the **Apple** menu, **Control Panel** and double-click **TCP/IP** to open the **TCP/IP Control Panel**.

Figure 253 Macintosh OS 8/9: Apple Menu



- 2 Select **Ethernet built-in** from the **Connect via** list.

Figure 254 Macintosh OS 8/9: TCP/IP

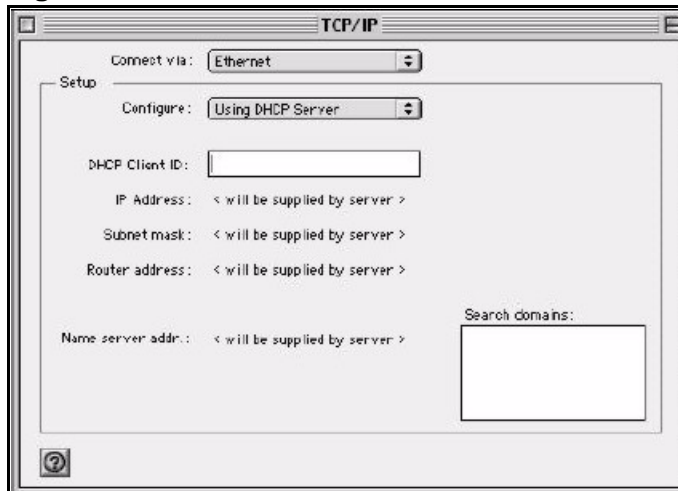

- 3 For dynamically assigned settings, select **Using DHCP Server** from the **Configure:** list.
- 4 For statically assigned settings, do the following:
 - From the **Configure** box, select **Manually**.
 - Type your IP address in the **IP Address** box.
 - Type your subnet mask in the **Subnet mask** box.
 - Type the IP address of your P-793H v2 in the **Router address** box.
- 5 Close the **TCP/IP Control Panel**.
- 6 Click **Save** if prompted, to save changes to your configuration.
- 7 Turn on your P-793H v2 and restart your computer (if prompted).

Verifying Settings

Check your TCP/IP properties in the **TCP/IP Control Panel** window.

Macintosh OS X

- 1 Click the **Apple** menu, and click **System Preferences** to open the **System Preferences** window.

Figure 255 Macintosh OS X: Apple Menu

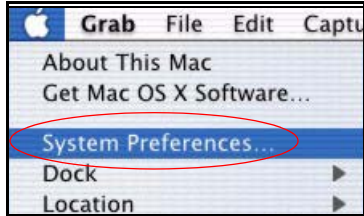

- 2 Click **Network** in the icon bar.
 - Select **Automatic** from the **Location** list.
 - Select **Built-in Ethernet** from the **Show** list.
 - Click the **TCP/IP** tab.
- 3 For dynamically assigned settings, select **Using DHCP** from the **Configure** list.

Figure 256 Macintosh OS X: Network

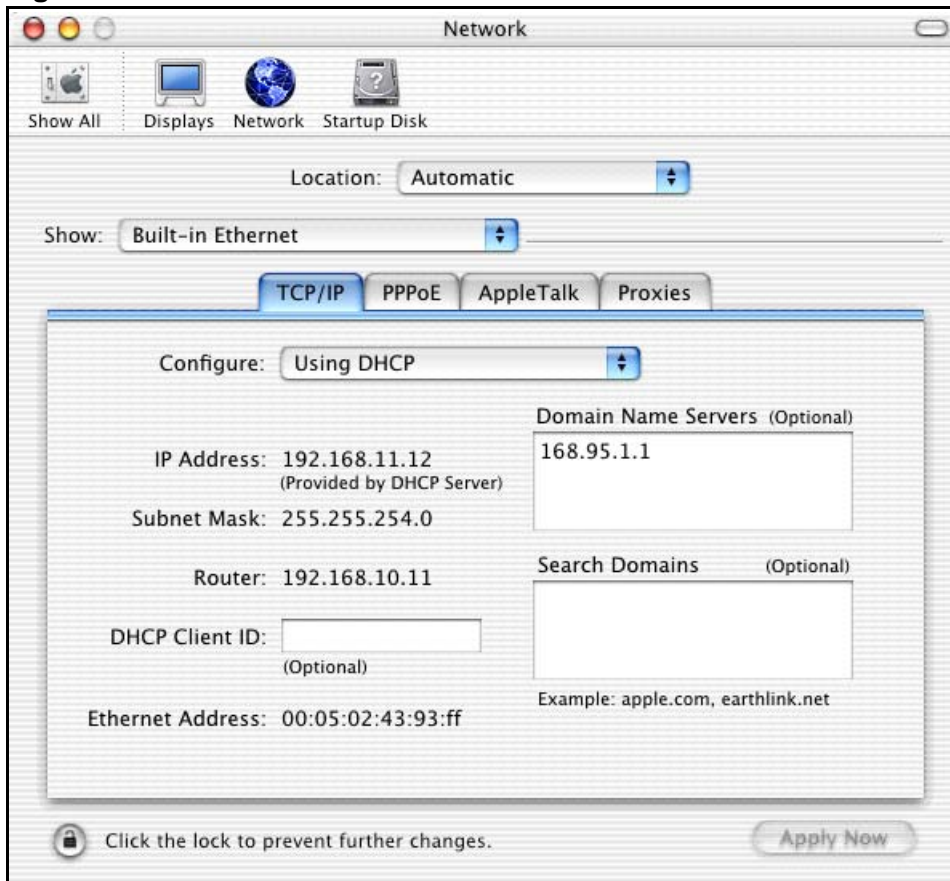

- 4 For statically assigned settings, do the following:

- From the **Configure** box, select **Manually**.
 - Type your IP address in the **IP Address** box.
 - Type your subnet mask in the **Subnet mask** box.
 - Type the IP address of your P-793H v2 in the **Router address** box.
- 5 Click **Apply Now** and close the window.
 - 6 Turn on your P-793H v2 and restart your computer (if prompted).

Verifying Settings

Check your TCP/IP properties in the **Network** window.

Linux

This section shows you how to configure your computer's TCP/IP settings in Red Hat Linux 9.0. Procedure, screens and file location may vary depending on your Linux distribution and release version.

Note: Make sure you are logged in as the root administrator.

Using the K Desktop Environment (KDE)

Follow the steps below to configure your computer IP address using the KDE.

- 1 Click the Red Hat button (located on the bottom left corner), select **System Setting** and click **Network**.

Figure 257 Red Hat 9.0: KDE: Network Configuration: Devices

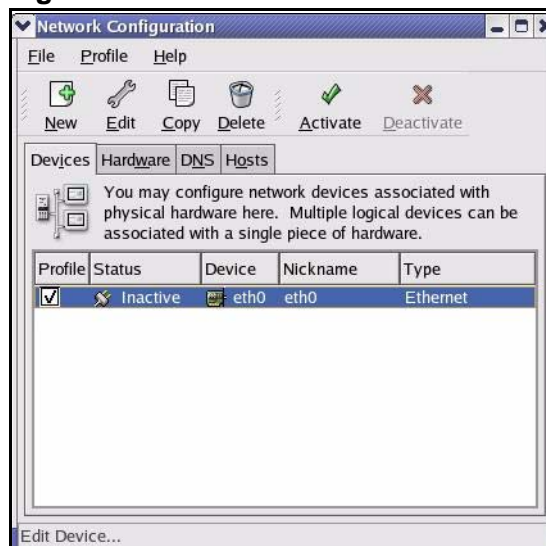

- 2 Double-click on the profile of the network card you wish to configure. The **Ethernet Device General** screen displays as shown.

Figure 258 Red Hat 9.0: KDE: Ethernet Device: General



- If you have a dynamic IP address, click **Automatically obtain IP address settings with** and select **dhcp** from the drop down list.
 - If you have a static IP address, click **Statically set IP Addresses** and fill in the **Address**, **Subnet mask**, and **Default Gateway Address** fields.
- 3 Click **OK** to save the changes and close the **Ethernet Device General** screen.
 - 4 If you know your DNS server IP address(es), click the **DNS** tab in the **Network Configuration** screen. Enter the DNS server information in the fields provided.

Figure 259 Red Hat 9.0: KDE: Network Configuration: DNS

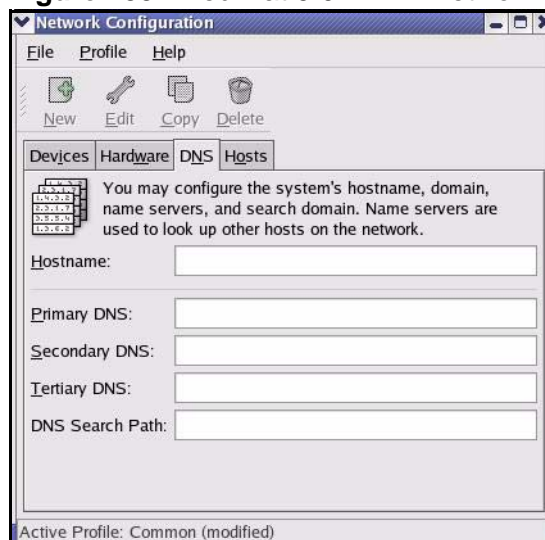

- 5 Click the **Devices** tab.

- Click the **Activate** button to apply the changes. The following screen displays. Click **Yes to save the changes in all screens**.

Figure 260 Red Hat 9.0: KDE: Network Configuration: Activate

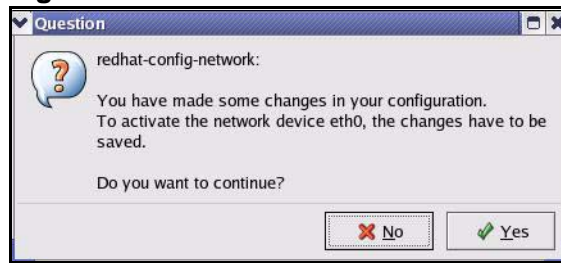

- After the network card restart process is complete, make sure the **Status** is **Active** in the **Network Configuration** screen.

Using Configuration Files

Follow the steps below to edit the network configuration files and set your computer IP address.

- Assuming that you have only one network card on the computer, locate the `ifconfig-eth0` configuration file (where `eth0` is the name of the Ethernet card). Open the configuration file with any plain text editor.
 - If you have a dynamic IP address, enter **dhcp** in the `BOOTPROTO=` field. The following figure shows an example.

Figure 261 Red Hat 9.0: Dynamic IP Address Setting in `ifconfig-eth0`

```
DEVICE=eth0
ONBOOT=yes
BOOTPROTO=dhcp
USERCTL=no
PEERDNS=yes
TYPE=Ethernet
```

- If you have a static IP address, enter **static** in the `BOOTPROTO=` field. Type `IPADDR=` followed by the IP address (in dotted decimal notation) and type `NETMASK=` followed by the subnet mask. The following example shows an example where the static IP address is 192.168.1.10 and the subnet mask is 255.255.255.0.

Figure 262 Red Hat 9.0: Static IP Address Setting in `ifconfig-eth0`

```
DEVICE=eth0
ONBOOT=yes
BOOTPROTO=static
IPADDR=192.168.1.10
NETMASK=255.255.255.0
USERCTL=no
PEERDNS=yes
TYPE=Ethernet
```

- 2 If you know your DNS server IP address(es), enter the DNS server information in the `resolv.conf` file in the `/etc` directory. The following figure shows an example where two DNS server IP addresses are specified.

Figure 263 Red Hat 9.0: DNS Settings in `resolv.conf`

```
nameserver 172.23.5.1
nameserver 172.23.5.2
```

- 3 After you edit and save the configuration files, you must restart the network card. Enter `./network restart` in the `/etc/rc.d/init.d` directory. The following figure shows an example.

Figure 264 Red Hat 9.0: Restart Ethernet Card

```
[root@localhost init.d]# network restart

Shutting down interface eth0:           [OK]
Shutting down loopback interface:       [OK]
Setting network parameters:            [OK]
Bringing up loopback interface:         [OK]
Bringing up interface eth0:            [OK]
```

Verifying Settings

Enter `ifconfig` in a terminal screen to check your TCP/IP properties.

Figure 265 Red Hat 9.0: Checking TCP/IP Properties

```
[root@localhost]# ifconfig
eth0      Link encap:Ethernet  HWaddr 00:50:BA:72:5B:44
          inet addr:172.23.19.129  Bcast:172.23.19.255  Mask:255.255.255.0
          UP BROADCAST RUNNING MULTICAST  MTU:1500  Metric:1
          RX packets:717 errors:0 dropped:0 overruns:0 frame:0
          TX packets:13 errors:0 dropped:0 overruns:0 carrier:0
          collisions:0 txqueuelen:100
          RX bytes:730412 (713.2 Kb)  TX bytes:1570 (1.5 Kb)
          Interrupt:10 Base address:0x1000
[root@localhost]#
```

Pop-up Windows, JavaScripts and Java Permissions

In order to use the web configurator you need to allow:

- Web browser pop-up windows from your device.
- JavaScripts (enabled by default).
- Java permissions (enabled by default).

Note: Internet Explorer 6 screens are used here. Screens for other Internet Explorer versions may vary.

Internet Explorer Pop-up Blockers

You may have to disable pop-up blocking to log into your device.

Either disable pop-up blocking (enabled by default in Windows XP SP (Service Pack) 2) or allow pop-up blocking and create an exception for your device's IP address.

Disable Pop-up Blockers

- 1 In Internet Explorer, select **Tools, Pop-up Blocker** and then select **Turn Off Pop-up Blocker**.

Figure 266 Pop-up Blocker

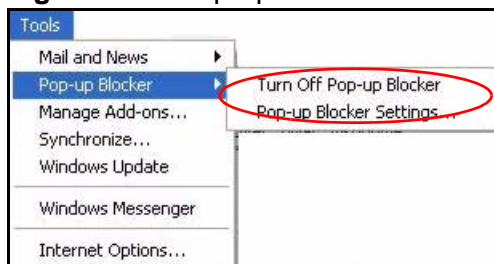

You can also check if pop-up blocking is disabled in the **Pop-up Blocker** section in the **Privacy** tab.

- 1 In Internet Explorer, select **Tools, Internet Options, Privacy**.
- 2 Clear the **Block pop-ups** check box in the **Pop-up Blocker** section of the screen. This disables any web pop-up blockers you may have enabled.

Figure 267 Internet Options: Privacy

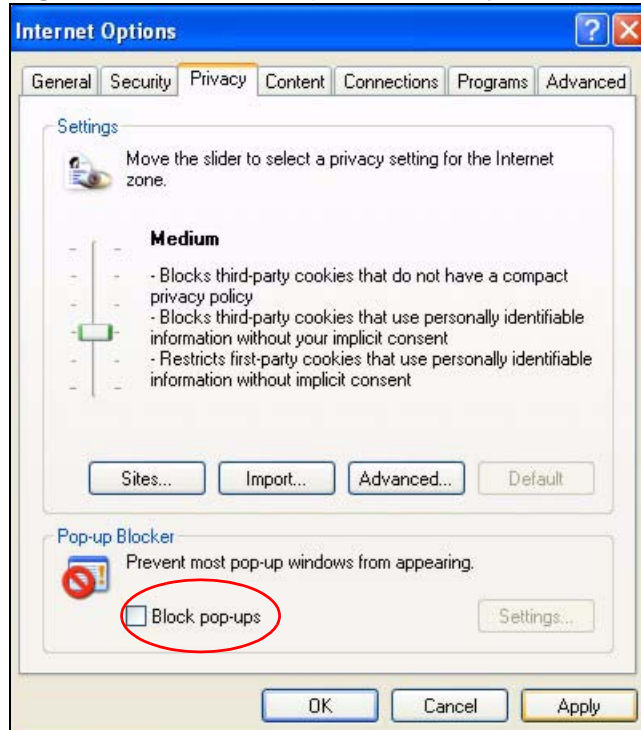

- 3 Click **Apply** to save this setting.

Enable Pop-up Blockers with Exceptions

Alternatively, if you only want to allow pop-up windows from your device, see the following steps.

- 1 In Internet Explorer, select **Tools, Internet Options** and then the **Privacy** tab.

- 2 Select **Settings...** to open the **Pop-up Blocker Settings** screen.

Figure 268 Internet Options: Privacy

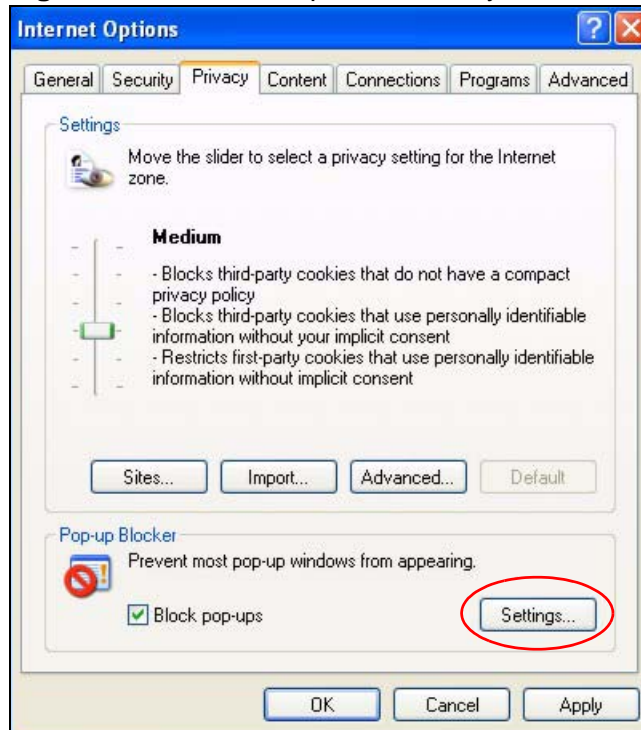

- 3 Type the IP address of your device (the web page that you do not want to have blocked) with the prefix "http://". For example, http://192.168.167.1.

- 4 Click **Add** to move the IP address to the list of **Allowed sites**.

Figure 269 Pop-up Blocker Settings

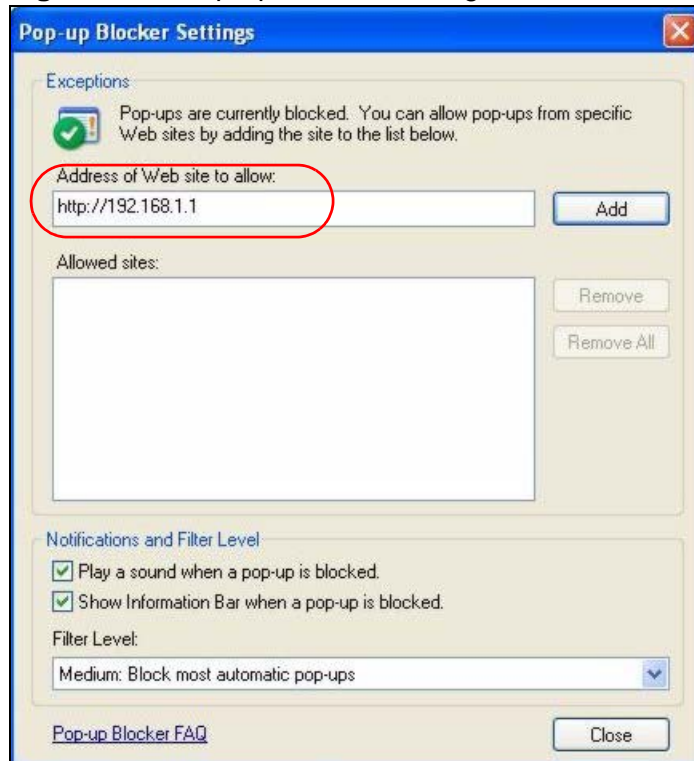

- 5 Click **Close** to return to the **Privacy** screen.
- 6 Click **Apply** to save this setting.

JavaScripts

If pages of the web configurator do not display properly in Internet Explorer, check that JavaScripts are allowed.

- 1 In Internet Explorer, click **Tools**, **Internet Options** and then the **Security** tab.

Figure 270 Internet Options: Security

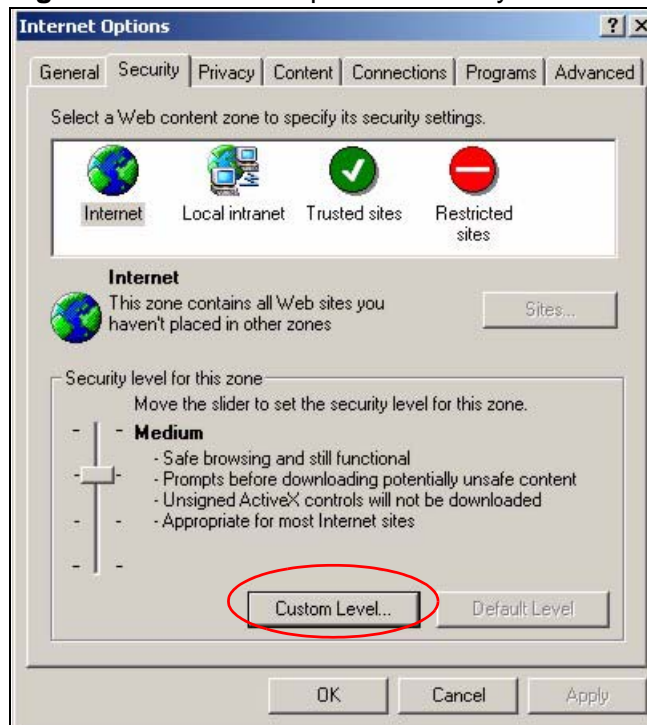

- 2 Click the **Custom Level...** button.
- 3 Scroll down to **Scripting**.
- 4 Under **Active scripting** make sure that **Enable** is selected (the default).
- 5 Under **Scripting of Java applets** make sure that **Enable** is selected (the default).

- 6 Click **OK** to close the window.

Figure 271 Security Settings - Java Scripting

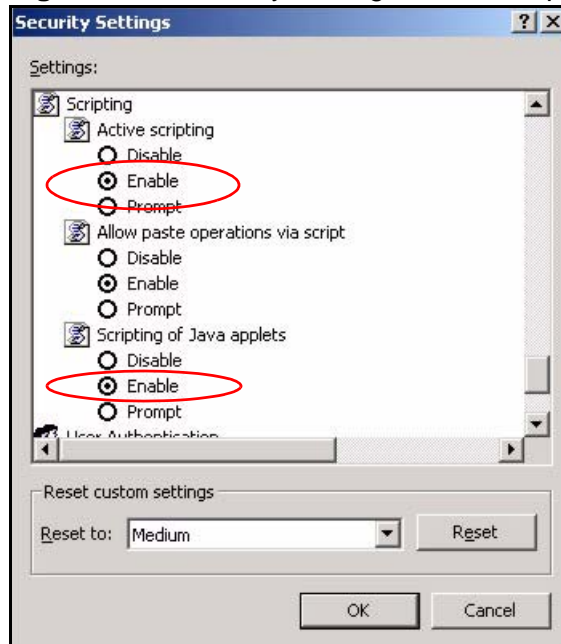

Java Permissions

- 1 From Internet Explorer, click **Tools, Internet Options** and then the **Security** tab.
- 2 Click the **Custom Level...** button.
- 3 Scroll down to **Microsoft VM**.
- 4 Under **Java permissions** make sure that a safety level is selected.

- 5 Click **OK** to close the window.

Figure 272 Security Settings - Java

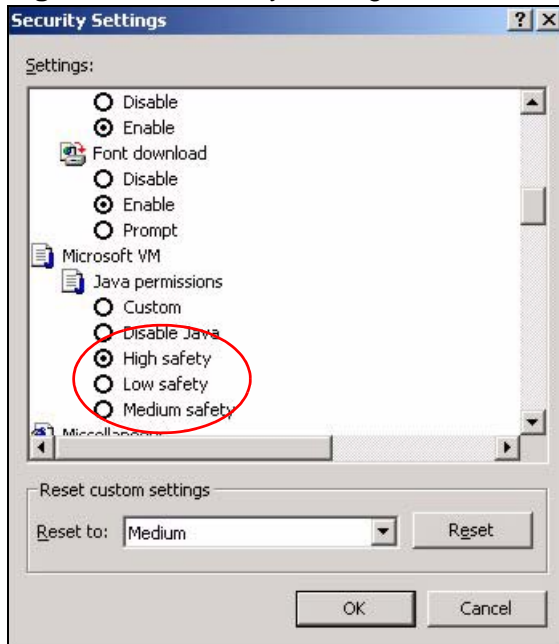

JAVA (Sun)

- 1 From Internet Explorer, click **Tools, Internet Options** and then the **Advanced** tab.
- 2 Make sure that **Use Java 2 for <applet>** under **Java (Sun)** is selected.

- 3 Click **OK** to close the window.

Figure 273 Java (Sun)

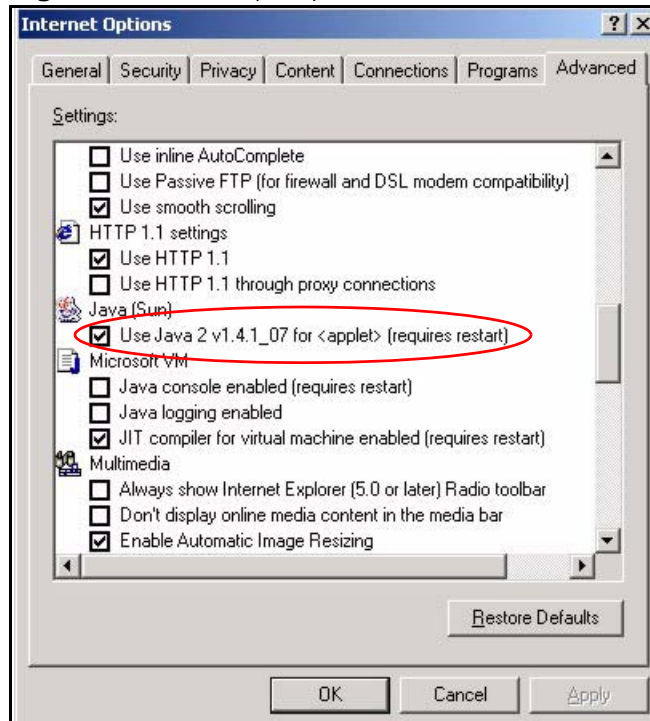

Mozilla Firefox

Mozilla Firefox 2.0 screens are used here. Screens for other versions may vary.

You can enable Java, Javascripts and pop-ups in one screen. Click **Tools**, then click **Options** in the screen that appears.

Figure 274 Mozilla Firefox: Tools > Options

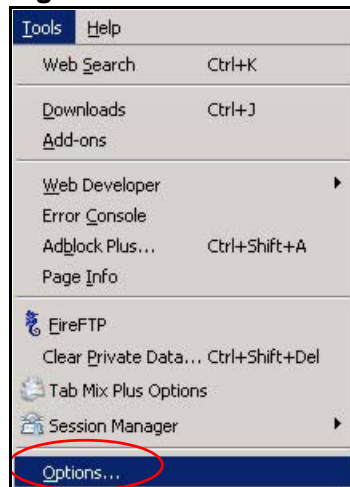

Click **Content** to show the screen below. Select the check boxes as shown in the following screen.

Figure 275 Mozilla Firefox Content Security

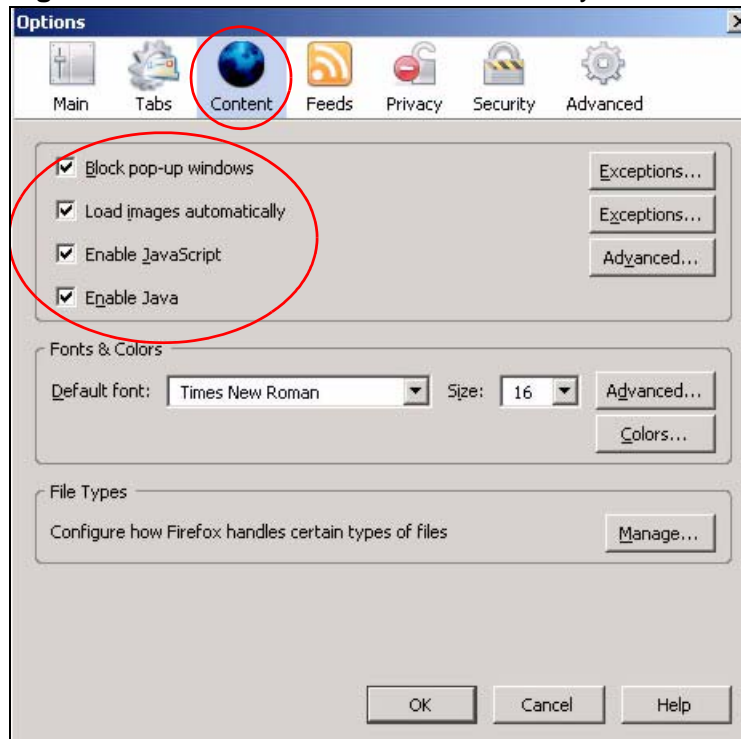

IP Addresses and Subnetting

This appendix introduces IP addresses and subnet masks.

IP addresses identify individual devices on a network. Every networking device (including computers, servers, routers, printers, etc.) needs an IP address to communicate across the network. These networking devices are also known as hosts.

Subnet masks determine the maximum number of possible hosts on a network. You can also use subnet masks to divide one network into multiple sub-networks.

Introduction to IP Addresses

One part of the IP address is the network number, and the other part is the host ID. In the same way that houses on a street share a common street name, the hosts on a network share a common network number. Similarly, as each house has its own house number, each host on the network has its own unique identifying number - the host ID. Routers use the network number to send packets to the correct network, while the host ID determines to which host on the network the packets are delivered.

Structure

An IP address is made up of four parts, written in dotted decimal notation (for example, 192.168.1.1). Each of these four parts is known as an octet. An octet is an eight-digit binary number (for example 11000000, which is 192 in decimal notation).

Therefore, each octet has a possible range of 00000000 to 11111111 in binary, or 0 to 255 in decimal.

The following figure shows an example IP address in which the first three octets (192.168.1) are the network number, and the fourth octet (16) is the host ID.

Figure 276 Network Number and Host ID

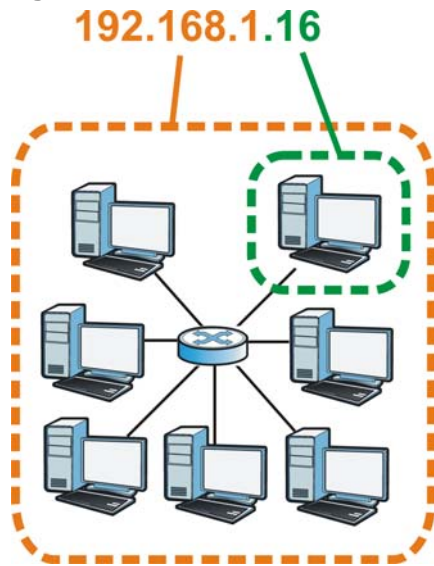

How much of the IP address is the network number and how much is the host ID varies according to the subnet mask.

Subnet Masks

A subnet mask is used to determine which bits are part of the network number, and which bits are part of the host ID (using a logical AND operation). The term “subnet” is short for “sub-network”.

A subnet mask has 32 bits. If a bit in the subnet mask is a “1” then the corresponding bit in the IP address is part of the network number. If a bit in the subnet mask is “0” then the corresponding bit in the IP address is part of the host ID.

The following example shows a subnet mask identifying the network number (in bold text) and host ID of an IP address (192.168.1.2 in decimal).

Table 148 Subnet Masks

	1ST OCTET: (192)	2ND OCTET: (168)	3RD OCTET: (1)	4TH OCTET (2)
IP Address (Binary)	11000000	10101000	00000001	00000010
Subnet Mask (Binary)	11111111	11111111	11111111	00000000
Network Number	11000000	10101000	00000001	
Host ID				00000010

By convention, subnet masks always consist of a continuous sequence of ones beginning from the leftmost bit of the mask, followed by a continuous sequence of zeros, for a total number of 32 bits.

Subnet masks can be referred to by the size of the network number part (the bits with a “1” value). For example, an “8-bit mask” means that the first 8 bits of the mask are ones and the remaining 24 bits are zeroes.

Subnet masks are expressed in dotted decimal notation just like IP addresses. The following examples show the binary and decimal notation for 8-bit, 16-bit, 24-bit and 29-bit subnet masks.

Table 149 Subnet Masks

	BINARY				DECIMAL
	1ST OCTET	2ND OCTET	3RD OCTET	4TH OCTET	
8-bit mask	11111111	00000000	00000000	00000000	255.0.0.0
16-bit mask	11111111	11111111	00000000	00000000	255.255.0.0
24-bit mask	11111111	11111111	11111111	00000000	255.255.255.0
29-bit mask	11111111	11111111	11111111	11111000	255.255.255.248

Network Size

The size of the network number determines the maximum number of possible hosts you can have on your network. The larger the number of network number bits, the smaller the number of remaining host ID bits.

An IP address with host IDs of all zeros is the IP address of the network (192.168.1.0 with a 24-bit subnet mask, for example). An IP address with host IDs of all ones is the broadcast address for that network (192.168.1.255 with a 24-bit subnet mask, for example).

As these two IP addresses cannot be used for individual hosts, calculate the maximum number of possible hosts in a network as follows:

Table 150 Maximum Host Numbers

SUBNET MASK		HOST ID SIZE		MAXIMUM NUMBER OF HOSTS
8 bits	255.0.0.0	24 bits	$2^{24} - 2$	16777214
16 bits	255.255.0.0	16 bits	$2^{16} - 2$	65534
24 bits	255.255.255.0	8 bits	$2^8 - 2$	254
29 bits	255.255.255.248	3 bits	$2^3 - 2$	6

Notation

Since the mask is always a continuous number of ones beginning from the left, followed by a continuous number of zeros for the remainder of the 32 bit mask, you can simply specify the number of ones instead of writing the value of each octet. This is usually specified by writing a "/" followed by the number of bits in the mask after the address.

For example, 192.1.1.0 /25 is equivalent to saying 192.1.1.0 with subnet mask 255.255.255.128.

The following table shows some possible subnet masks using both notations.

Table 151 Alternative Subnet Mask Notation

SUBNET MASK	ALTERNATIVE NOTATION	LAST OCTET (BINARY)	LAST OCTET (DECIMAL)
255.255.255.0	/24	0000 0000	0
255.255.255.128	/25	1000 0000	128
255.255.255.192	/26	1100 0000	192
255.255.255.224	/27	1110 0000	224
255.255.255.240	/28	1111 0000	240
255.255.255.248	/29	1111 1000	248
255.255.255.252	/30	1111 1100	252

Subnetting

You can use subnetting to divide one network into multiple sub-networks. In the following example a network administrator creates two sub-networks to isolate a group of servers from the rest of the company network for security reasons.

In this example, the company network address is 192.168.1.0. The first three octets of the address (192.168.1) are the network number, and the remaining octet is the host ID, allowing a maximum of $2^8 - 2$ or 254 possible hosts.

The following figure shows the company network before subnetting.

Figure 277 Subnetting Example: Before Subnetting

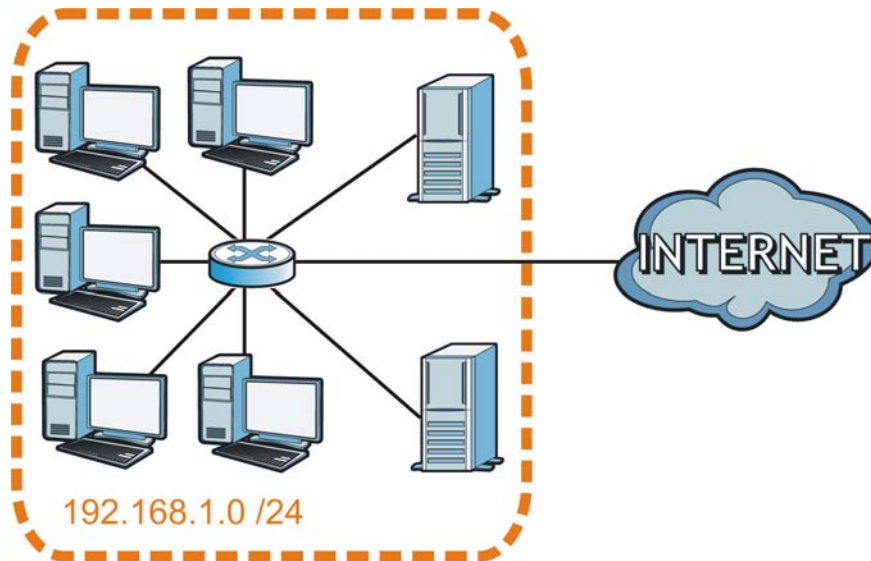

You can “borrow” one of the host ID bits to divide the network `192.168.1.0` into two separate sub-networks. The subnet mask is now 25 bits (`255.255.255.128` or `/25`).

The “borrowed” host ID bit can have a value of either 0 or 1, allowing two subnets; `192.168.1.0 /25` and `192.168.1.128 /25`.

The following figure shows the company network after subnetting. There are now two sub-networks, **A** and **B**.

Figure 278 Subnetting Example: After Subnetting

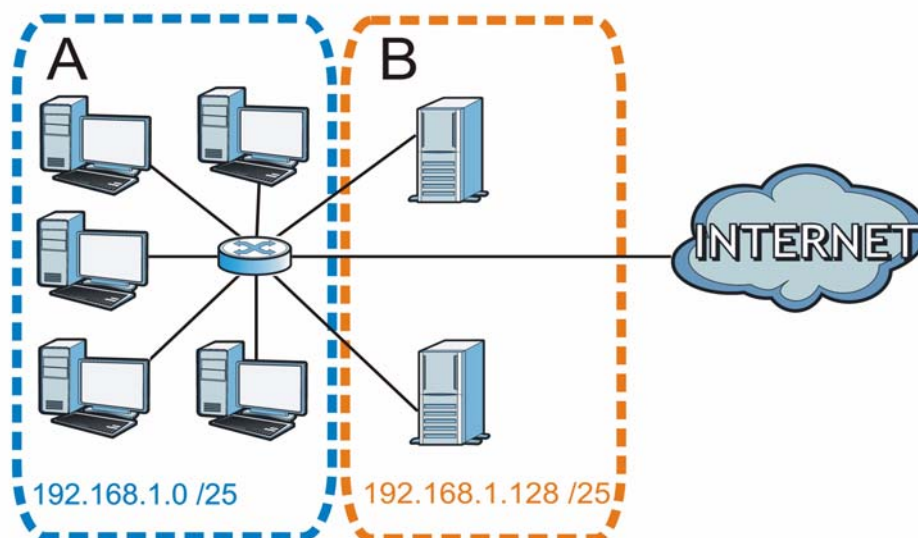

In a 25-bit subnet the host ID has 7 bits, so each sub-network has a maximum of $2^7 - 2$ or 126 possible hosts (a host ID of all zeroes is the subnet's address itself, all ones is the subnet's broadcast address).

192.168.1.0 with mask 255.255.255.128 is subnet **A** itself, and 192.168.1.127 with mask 255.255.255.128 is its broadcast address. Therefore, the lowest IP address that can be assigned to an actual host for subnet **A** is 192.168.1.1 and the highest is 192.168.1.126.

Similarly, the host ID range for subnet **B** is 192.168.1.129 to 192.168.1.254.

Example: Four Subnets

The previous example illustrated using a 25-bit subnet mask to divide a 24-bit address into two subnets. Similarly, to divide a 24-bit address into four subnets, you need to "borrow" two host ID bits to give four possible combinations (00, 01, 10 and 11). The subnet mask is 26 bits (11111111.11111111.11111111.11000000) or 255.255.255.192.

Each subnet contains 6 host ID bits, giving $2^6 - 2$ or 62 hosts for each subnet (a host ID of all zeroes is the subnet itself, all ones is the subnet's broadcast address).

Table 152 Subnet 1

IP/SUBNET MASK	NETWORK NUMBER	LAST OCTET BIT VALUE
IP Address (Decimal)	192.168.1.	0
IP Address (Binary)	11000000.10101000.00000001.	00000000
Subnet Mask (Binary)	11111111.11111111.11111111.	11000000
Subnet Address: 192.168.1.0	Lowest Host ID: 192.168.1.1	
Broadcast Address: 192.168.1.63	Highest Host ID: 192.168.1.62	

Table 153 Subnet 2

IP/SUBNET MASK	NETWORK NUMBER	LAST OCTET BIT VALUE
IP Address	192.168.1.	64
IP Address (Binary)	11000000.10101000.00000001.	01000000
Subnet Mask (Binary)	11111111.11111111.11111111.	11000000
Subnet Address: 192.168.1.64	Lowest Host ID: 192.168.1.65	
Broadcast Address: 192.168.1.127	Highest Host ID: 192.168.1.126	

Table 154 Subnet 3

IP/SUBNET MASK	NETWORK NUMBER	LAST OCTET BIT VALUE
IP Address	192.168.1.	128
IP Address (Binary)	11000000.10101000.00000001.	10000000
Subnet Mask (Binary)	11111111.11111111.11111111.	11000000
Subnet Address: 192.168.1.128	Lowest Host ID: 192.168.1.129	
Broadcast Address: 192.168.1.191	Highest Host ID: 192.168.1.190	

Table 155 Subnet 4

IP/SUBNET MASK	NETWORK NUMBER	LAST OCTET BIT VALUE
IP Address	192.168.1.	192
IP Address (Binary)	11000000.10101000.00000001.	11000000
Subnet Mask (Binary)	11111111.11111111.11111111.	11000000
Subnet Address: 192.168.1.192	Lowest Host ID: 192.168.1.193	
Broadcast Address: 192.168.1.255	Highest Host ID: 192.168.1.254	

Example: Eight Subnets

Similarly, use a 27-bit mask to create eight subnets (000, 001, 010, 011, 100, 101, 110 and 111).

The following table shows IP address last octet values for each subnet.

Table 156 Eight Subnets

SUBNET	SUBNET ADDRESS	FIRST ADDRESS	LAST ADDRESS	BROADCAST ADDRESS
1	0	1	30	31
2	32	33	62	63
3	64	65	94	95
4	96	97	126	127
5	128	129	158	159
6	160	161	190	191
7	192	193	222	223
8	224	225	254	255

Subnet Planning

The following table is a summary for subnet planning on a network with a 24-bit network number.

Table 157 24-bit Network Number Subnet Planning

NO. "BORROWED" HOST BITS	SUBNET MASK	NO. SUBNETS	NO. HOSTS PER SUBNET
1	255.255.255.128 (/25)	2	126
2	255.255.255.192 (/26)	4	62
3	255.255.255.224 (/27)	8	30
4	255.255.255.240 (/28)	16	14
5	255.255.255.248 (/29)	32	6
6	255.255.255.252 (/30)	64	2
7	255.255.255.254 (/31)	128	1

The following table is a summary for subnet planning on a network with a 16-bit network number.

Table 158 16-bit Network Number Subnet Planning

NO. "BORROWED" HOST BITS	SUBNET MASK	NO. SUBNETS	NO. HOSTS PER SUBNET
1	255.255.128.0 (/17)	2	32766
2	255.255.192.0 (/18)	4	16382
3	255.255.224.0 (/19)	8	8190
4	255.255.240.0 (/20)	16	4094
5	255.255.248.0 (/21)	32	2046
6	255.255.252.0 (/22)	64	1022
7	255.255.254.0 (/23)	128	510
8	255.255.255.0 (/24)	256	254
9	255.255.255.128 (/25)	512	126
10	255.255.255.192 (/26)	1024	62
11	255.255.255.224 (/27)	2048	30
12	255.255.255.240 (/28)	4096	14
13	255.255.255.248 (/29)	8192	6
14	255.255.255.252 (/30)	16384	2
15	255.255.255.254 (/31)	32768	1

Configuring IP Addresses

Where you obtain your network number depends on your particular situation. If the ISP or your network administrator assigns you a block of registered IP

addresses, follow their instructions in selecting the IP addresses and the subnet mask.

If the ISP did not explicitly give you an IP network number, then most likely you have a single user account and the ISP will assign you a dynamic IP address when the connection is established. If this is the case, it is recommended that you select a network number from 192.168.0.0 to 192.168.255.0. The Internet Assigned Number Authority (IANA) reserved this block of addresses specifically for private use; please do not use any other number unless you are told otherwise. You must also enable Network Address Translation (NAT) on the P-793H v2.

Once you have decided on the network number, pick an IP address for your P-793H v2 that is easy to remember (for instance, 192.168.1.1) but make sure that no other device on your network is using that IP address.

The subnet mask specifies the network number portion of an IP address. Your P-793H v2 will compute the subnet mask automatically based on the IP address that you entered. You don't need to change the subnet mask computed by the P-793H v2 unless you are instructed to do otherwise.

Private IP Addresses

Every machine on the Internet must have a unique address. If your networks are isolated from the Internet (running only between two branch offices, for example) you can assign any IP addresses to the hosts without problems. However, the Internet Assigned Numbers Authority (IANA) has reserved the following three blocks of IP addresses specifically for private networks:

- 10.0.0.0 — 10.255.255.255
- 172.16.0.0 — 172.31.255.255
- 192.168.0.0 — 192.168.255.255

You can obtain your IP address from the IANA, from an ISP, or it can be assigned from a private network. If you belong to a small organization and your Internet access is through an ISP, the ISP can provide you with the Internet addresses for your local networks. On the other hand, if you are part of a much larger organization, you should consult your network administrator for the appropriate IP addresses.

Regardless of your particular situation, do not create an arbitrary IP address; always follow the guidelines above. For more information on address assignment, please refer to RFC 1597, *Address Allocation for Private Internets* and RFC 1466, *Guidelines for Management of IP Address Space*.

Services

The following table lists some commonly-used services and their associated protocols and port numbers.

- **Name:** This is a short, descriptive name for the service. You can use this one or create a different one, if you like.
- **Protocol:** This is the type of IP protocol used by the service. If this is **TCP/UDP**, then the service uses the same port number with TCP and UDP. If this is **USER-DEFINED**, the **Port(s)** is the IP protocol number, not the port number.
- **Port(s):** This value depends on the **Protocol**.
 - If the **Protocol** is **TCP, UDP, or TCP/UDP**, this is the IP port number.
 - If the **Protocol** is **USER**, this is the IP protocol number.
- **Description:** This is a brief explanation of the applications that use this service or the situations in which this service is used.

Table 159 Examples of Services

NAME	PROTOCOL	PORT(S)	DESCRIPTION
AH (IPSEC_TUNNEL)	User-Defined	51	The IPSEC AH (Authentication Header) tunneling protocol uses this service.
AIM	TCP	5190	AOL's Internet Messenger service.
AUTH	TCP	113	Authentication protocol used by some servers.
BGP	TCP	179	Border Gateway Protocol.
BOOTP_CLIENT	UDP	68	DHCP Client.
BOOTP_SERVER	UDP	67	DHCP Server.
CU-SEEME	TCP/UDP TCP/UDP	7648 24032	A popular videoconferencing solution from White Pines Software.
DNS	TCP/UDP	53	Domain Name Server, a service that matches web names (for instance www.zyxel.com) to IP numbers.
ESP (IPSEC_TUNNEL)	User-Defined	50	The IPSEC ESP (Encapsulation Security Protocol) tunneling protocol uses this service.
FINGER	TCP	79	Finger is a UNIX or Internet related command that can be used to find out if a user is logged on.
FTP	TCP TCP	20 21	File Transfer Protocol, a program to enable fast transfer of files, including large files that may not be possible by e-mail.
H.323	TCP	1720	NetMeeting uses this protocol.
HTTP	TCP	80	Hyper Text Transfer Protocol - a client/server protocol for the world wide web.
HTTPS	TCP	443	HTTPS is a secured http session often used in e-commerce.
ICMP	User-Defined	1	Internet Control Message Protocol is often used for diagnostic purposes.
ICQ	UDP	4000	This is a popular Internet chat program.
IGMP (MULTICAST)	User-Defined	2	Internet Group Multicast Protocol is used when sending packets to a specific group of hosts.
IKE	UDP	500	The Internet Key Exchange algorithm is used for key distribution and management.
IMAP4	TCP	143	The Internet Message Access Protocol is used for e-mail.
IMAP4S	TCP	993	This is a more secure version of IMAP4 that runs over SSL.
IRC	TCP/UDP	6667	This is another popular Internet chat program.

Table 159 Examples of Services (continued)

NAME	PROTOCOL	PORT(S)	DESCRIPTION
MSN Messenger	TCP	1863	Microsoft Networks' messenger service uses this protocol.
NetBIOS	TCP/UDP	137	The Network Basic Input/Output System is used for communication between computers in a LAN.
	TCP/UDP	138	
	TCP/UDP	139	
	TCP/UDP	445	
NEW-ICQ	TCP	5190	An Internet chat program.
NEWS	TCP	144	A protocol for news groups.
NFS	UDP	2049	Network File System - NFS is a client/server distributed file service that provides transparent file sharing for network environments.
NNTP	TCP	119	Network News Transport Protocol is the delivery mechanism for the USENET newsgroup service.
PING	User-Defined	1	Packet INternet Groper is a protocol that sends out ICMP echo requests to test whether or not a remote host is reachable.
POP3	TCP	110	Post Office Protocol version 3 lets a client computer get e-mail from a POP3 server through a temporary connection (TCP/IP or other).
POP3S	TCP	995	This is a more secure version of POP3 that runs over SSL.
PPTP	TCP	1723	Point-to-Point Tunneling Protocol enables secure transfer of data over public networks. This is the control channel.
PPTP_TUNNEL (GRE)	User-Defined	47	PPTP (Point-to-Point Tunneling Protocol) enables secure transfer of data over public networks. This is the data channel.
RCMD	TCP	512	Remote Command Service.
REAL_AUDIO	TCP	7070	A streaming audio service that enables real time sound over the web.
REXEC	TCP	514	Remote Execution Daemon.
RLOGIN	TCP	513	Remote Login.
ROADRUNNER	TCP/UDP	1026	This is an ISP that provides services mainly for cable modems.
RTELNET	TCP	107	Remote Telnet.
RTSP	TCP/UDP	554	The Real Time Streaming (media control) Protocol (RTSP) is a remote control for multimedia on the Internet.

Table 159 Examples of Services (continued)

NAME	PROTOCOL	PORT(S)	DESCRIPTION
SFTP	TCP	115	The Simple File Transfer Protocol is an old way of transferring files between computers.
SMTP	TCP	25	Simple Mail Transfer Protocol is the message-exchange standard for the Internet. SMTP enables you to move messages from one e-mail server to another.
SMTPS	TCP	465	This is a more secure version of SMTP that runs over SSL.
SNMP	TCP/UDP	161	Simple Network Management Program.
SNMP-TRAPS	TCP/UDP	162	Traps for use with the SNMP (RFC: 1215).
SQL-NET	TCP	1521	Structured Query Language is an interface to access data on many different types of database systems, including mainframes, midrange systems, UNIX systems and network servers.
SSDP	UDP	1900	The Simple Service Discovery Protocol supports Universal Plug-and-Play (UPnP).
SSH	TCP/UDP	22	Secure Shell Remote Login Program.
STRM WORKS	UDP	1558	Stream Works Protocol.
SYSLOG	UDP	514	Syslog allows you to send system logs to a UNIX server.
TACACS	UDP	49	Login Host Protocol used for (Terminal Access Controller Access Control System).
TELNET	TCP	23	Telnet is the login and terminal emulation protocol common on the Internet and in UNIX environments. It operates over TCP/IP networks. Its primary function is to allow users to log into remote host systems.
TFTP	UDP	69	Trivial File Transfer Protocol is an Internet file transfer protocol similar to FTP, but uses the UDP (User Datagram Protocol) rather than TCP (Transmission Control Protocol).
VDOLIVE	TCP UDP	7000 user- defined	A videoconferencing solution. The UDP port number is specified in the application.

Legal Information

Copyright

Copyright © 2010 by ZyXEL Communications Corporation.

The contents of this publication may not be reproduced in any part or as a whole, transcribed, stored in a retrieval system, translated into any language, or transmitted in any form or by any means, electronic, mechanical, magnetic, optical, chemical, photocopying, manual, or otherwise, without the prior written permission of ZyXEL Communications Corporation.

Published by ZyXEL Communications Corporation. All rights reserved.

Disclaimer

ZyXEL does not assume any liability arising out of the application or use of any products, or software described herein. Neither does it convey any license under its patent rights nor the patent rights of others. ZyXEL further reserves the right to make changes in any products described herein without notice. This publication is subject to change without notice.

Trademarks

ZyNOS (ZyXEL Network Operating System) is a registered trademark of ZyXEL Communications, Inc. Other trademarks mentioned in this publication are used for identification purposes only and may be properties of their respective owners.

Certifications

Federal Communications Commission (FCC) Interference Statement

The device complies with Part 15 of FCC rules. Operation is subject to the following two conditions:

- This device may not cause harmful interference.

- This device must accept any interference received, including interference that may cause undesired operations.

This device has been tested and found to comply with the limits for a Class B digital device pursuant to Part 15 of the FCC Rules. These limits are designed to provide reasonable protection against harmful interference in a residential installation. This device generates, uses, and can radiate radio frequency energy, and if not installed and used in accordance with the instructions, may cause harmful interference to radio communications. However, there is no guarantee that interference will not occur in a particular installation.

If this device does cause harmful interference to radio/television reception, which can be determined by turning the device off and on, the user is encouraged to try to correct the interference by one or more of the following measures:

- 1 Reorient or relocate the receiving antenna.
- 2 Increase the separation between the equipment and the receiver.
- 3 Connect the equipment into an outlet on a circuit different from that to which the receiver is connected.
- 4 Consult the dealer or an experienced radio/TV technician for help.



FCC Radiation Exposure Statement

- This transmitter must not be co-located or operating in conjunction with any other antenna or transmitter.
- IEEE 802.11b or 802.11g operation of this product in the U.S.A. is firmware-limited to channels 1 through 11.
- To comply with FCC RF exposure compliance requirements, a separation distance of at least 20 cm must be maintained between the antenna of this device and all persons.

注意！

依據 低功率電波輻射性電機管理辦法

第十二條 經型式認證合格之低功率射頻電機，非經許可，公司、商號或使用者均不得擅自變更頻率、加大功率或變更原設計之特性及功能。

第十四條 低功率射頻電機之使用不得影響飛航安全及干擾合法通信；經發現有干擾現象時，應立即停用，並改善至無干擾時方得繼續使用。

前項合法通信，指依電信規定作業之無線電信。低功率射頻電機須忍受合法通信或工業、科學及醫療用電波輻射性電機設備之干擾。

本機限在不干擾合法電臺與不受被干擾保障條件下於室內使用。
減少電磁波影響，請妥適使用。

Notices

Changes or modifications not expressly approved by the party responsible for compliance could void the user's authority to operate the equipment.

This Class B digital apparatus complies with Canadian ICES-003.

Cet appareil numérique de la classe B est conforme à la norme NMB-003 du Canada.

Viewing Certifications

- 1 Go to <http://www.zyxel.com>.
- 2 Select your product on the ZyXEL home page to go to that product's page.
- 3 Select the certification you wish to view from this page.

ZyXEL Limited Warranty

ZyXEL warrants to the original end user (purchaser) that this product is free from any defects in materials or workmanship for a period of up to two years from the date of purchase. During the warranty period, and upon proof of purchase, should the product have indications of failure due to faulty workmanship and/or materials, ZyXEL will, at its discretion, repair or replace the defective products or components without charge for either parts or labor, and to whatever extent it shall deem necessary to restore the product or components to proper operating condition. Any replacement will consist of a new or re-manufactured functionally equivalent product of equal or higher value, and will be solely at the discretion of ZyXEL. This warranty shall not apply if the product has been modified, misused, tampered with, damaged by an act of God, or subjected to abnormal working conditions.

Note

Repair or replacement, as provided under this warranty, is the exclusive remedy of the purchaser. This warranty is in lieu of all other warranties, express or implied, including any implied warranty of merchantability or fitness for a particular use or purpose. ZyXEL shall in no event be held liable for indirect or consequential damages of any kind to the purchaser.

To obtain the services of this warranty, contact your vendor. You may also refer to the warranty policy for the region in which you bought the device at http://www.zyxel.com/web/support_warranty_info.php.

Registration

Register your product online to receive e-mail notices of firmware upgrades and information at www.zyxel.com.

Index

Numerics

- 802.1Q/1P [207](#)
 - activation [213](#)
 - example [209](#)
 - group settings [214](#)
 - management VLAN [213](#)
 - port settings [215](#)
 - priority [207](#), [216](#)
 - PVC [208](#)
 - PVID [216](#)
 - tagging frames [208](#), [215](#)

A

- activation
 - 802.1Q/1P [213](#)
 - classifiers [224](#)
 - content filtering [158](#)
 - dynamic DNS [236](#)
 - DYNDNS wildcard [236](#)
 - firewalls [139](#)
 - NAT [119](#)
 - port forwarding [123](#)
 - QoS [223](#)
 - SIP ALG [127](#)
 - static route [204](#)
 - UPnP [253](#)
- address mapping [123](#)
 - rules [125](#)
 - types [125](#), [126](#), [130](#)
- administrator password [265](#)
- AH [180](#)
- alerts [269](#)
 - firewalls [143](#)
- algorithm, certificates [199](#)
 - MD5 fingerprint [199](#)
 - SHA1 fingerprint [199](#)
- algorithms [180](#)
- alternative subnet mask notation [466](#)
- anti-probing [134](#)

- Any IP
 - status [54](#)
- applications
 - high-speed Internet access [37](#)
 - point-to-point connections [38](#)
- applications, NAT [130](#)
- asymmetrical routes [139](#)
- Asynchronous Transfer Mode, see ATM
- ATM [76](#), [299](#)
 - MBS [84](#), [91](#)
 - PCR [84](#), [91](#)
 - QoS [84](#), [90](#), [99](#)
 - SCR [84](#), [91](#)
 - status [299](#)

B

- backup
 - configuration [288](#), [289](#), [293](#)
- backup type [92](#)
- bandwidth management [223](#)
- broadcast [76](#)
- budget management [404](#)

C

- CA [193](#)
 - algorithm [199](#)
 - trusted [195](#), [198](#)
- call control [404](#)
- call history [404](#)
- CBR [84](#), [90](#), [99](#)
- certificates [193](#), [200](#)
 - advantages [200](#)
 - algorithm [199](#)
 - CA [193](#)
 - trusted [195](#), [198](#)
 - example [193](#)

- exporting [199](#)
 - factory-default [194](#)
 - formats [193](#)
 - PEM [199](#)
 - thumbprint algorithms [195](#)
 - thumbprints [195](#)
 - verifying fingerprints [194](#)
 - Certification Authority, see CA
 - certifications [477](#)
 - notices [479](#)
 - viewing [479](#)
 - Change Password screen [44](#)
 - Class of Service, see CoS
 - classifiers [224](#)
 - 802.1Q tags [228](#)
 - activation [224](#)
 - configuration [226](#)
 - creation [224](#)
 - DSCP [227](#), [229](#)
 - FTP [229](#)
 - priority [227](#)
 - remote node [229](#)
 - routing policy [227](#)
 - SIP [229](#)
 - client list [108](#)
 - command interface [39](#)
 - Command Interpreter (CI) [403](#)
 - command syntax [403](#)
 - command usage [404](#)
 - configuration [293](#)
 - backup [288](#), [289](#), [293](#)
 - classifiers [226](#)
 - DHCP [107](#)
 - file [284](#)
 - firewalls [138](#), [142](#), [147](#)
 - IP alias [110](#)
 - logs [271](#)
 - port forwarding [121](#)
 - reset [295](#)
 - restoring [285](#), [293](#)
 - SNMP [247](#)
 - static route [205](#)
 - WAN [78](#)
 - wizard [60](#)
 - configuration file [387](#)
 - back up [388](#)
 - back up using FTP [389](#)
 - backing up using console port [392](#)
 - backing up using TFTP [391](#)
 - restore [393](#)
 - restoring using console port [395](#)
 - restoring using FTP [394](#)
 - connection
 - nailed-up [89](#), [96](#)
 - on demand [89](#)
 - console port
 - for backing up configuration file [392](#)
 - for restoring configuration file [395](#)
 - for upgrading firmware [400](#)
 - content filtering [155](#)
 - activation [158](#)
 - example [156](#)
 - keywords [158](#)
 - schedules [159](#)
 - trusted IP addresses [160](#)
 - URL [155](#)
 - copyright [477](#)
 - CoS [218](#)
 - DiffServ [232](#)
 - creation
 - classifiers [224](#)
 - customized services [143](#), [144](#), [145](#)
- ## D
- data filter set. See filter set, data.
 - default password [44](#)
 - default server, NAT [120](#), [122](#)
 - default URL [43](#)
 - Denials of Service, see DoS
 - DH [188](#)
 - DHCP [102](#), [107](#), [112](#), [263](#)
 - diagnostic [297](#)
 - Differentiated Services, see DiffServ
 - Diffie-Hellman key groups [188](#)
 - DiffServ [232](#)
 - DiffServ Code Point, see DSCP
 - disclaimer [477](#)
 - DNS [80](#), [102](#), [107](#), [112](#), [248](#)
 - DNS Server
 - for VPN host [185](#)
 - Domain Name System, see DNS

- DoS [134](#)
 - three-way handshake [145](#)
 - thresholds [134](#), [145](#), [146](#), [147](#)
 - DSCP [227](#), [229](#), [232](#)
 - DSL connections, status [300](#)
 - DSL interface [76](#)
 - dynamic DNS [235](#)
 - activation [236](#)
 - wildcard [235](#)
 - activation [236](#)
 - Dynamic Host Configuration Protocol, see DHCP
 - dynamic secure gateway address [163](#)
 - DYNDNS wildcard [235](#)
 - activation [236](#)
- ## E
- e-mail logs [272](#)
 - encapsulation [76](#), [79](#), [88](#), [183](#)
 - ENET ENCAP [94](#)
 - PPPoA [94](#)
 - PPPoE [94](#)
 - RFC 1483 [94](#)
 - ENET ENCAP [79](#), [88](#), [94](#)
 - ESP [180](#)
 - exporting
 - trusted CA [199](#)
- ## F
- FCC interference statement [477](#)
 - filter set [357](#)
 - and firewall [370](#)
 - and NAT [369](#)
 - and remote node [330](#)
 - data [357](#)
 - generic filter rule [366](#)
 - structure [358](#)
 - TCP/IP filter rule [362](#)
 - filters
 - content [155](#)
 - activation [158](#)
 - example [156](#)
 - keywords [158](#)
 - schedules [159](#)
 - trusted IP addresses [160](#)
 - URL [155](#)
 - firewall
 - and filter set [370](#)
 - firewalls [133](#)
 - actions [143](#)
 - activation [139](#)
 - address types [143](#)
 - alerts [143](#)
 - anti-probing [134](#)
 - asymmetrical routes [139](#)
 - configuration [138](#), [142](#), [147](#)
 - customized services [143](#), [144](#), [145](#)
 - default action [139](#)
 - DoS [134](#)
 - thresholds [134](#), [145](#), [146](#), [147](#)
 - example [135](#)
 - half-open sessions [148](#)
 - ICMP [134](#)
 - logs [143](#)
 - maximum incomplete [148](#)
 - P2P [147](#)
 - packet direction [139](#)
 - rules [140](#), [149](#)
 - schedules [143](#)
 - security [150](#)
 - status [52](#)
 - three-way handshake [145](#)
 - triangle route [139](#), [151](#), [152](#)
 - solutions [152](#)
 - firmware [284](#), [291](#)
 - upgrading [286](#)
 - version [52](#)
 - firmware upgrade [387](#), [396](#), [400](#)
 - using FTP [398](#)
 - using TFTP [399](#)
 - forwarding ports [118](#), [120](#)
 - activation [123](#)
 - configuration [121](#)
 - example [121](#)
 - rules [122](#)
 - front panel [40](#)
 - FTP [39](#), [243](#)
 - backing up configuration [288](#)
 - for backing up configuration file [389](#)
 - for restoring configuration file [394](#)
 - for upgrading firmware [398](#)
 - limitations [285](#)

QoS [229](#)
restoring configuration [285, 286](#)
upgrading firmware [286, 287](#)

H

half-open sessions [148](#)
high-speed Internet access [37](#)
HTTPS
 authenticating clients [241](#)

I

IANA [471](#)
 Internet Assigned Numbers Authority
 see IANA
ICMP [134, 249](#)
ID type and content [186](#)
IGA [128](#)
IGMP [77, 102, 105, 115](#)
IKE phases [184](#)
ILA [128](#)
importing
 trusted CA [196](#)
Inside Global Address, see IGA
inside header [183](#)
Inside Local Address, see ILA
installation
 wall-mounting [427](#)
Internet Control Message Protocol, see ICMP
Internet Group Multicast Protocol, see IGMP
Internet Key Exchange [184](#)
Internet Protocol Security, see IPSec
IP address [76, 80, 88, 95, 102, 113](#)
 default server [120, 122](#)
 ping [297](#)
 private [113](#)
IP alias [109](#)
 and traffic redirect [97](#)
 configuration [110](#)
 NAT applications [130](#)
IP precedence [231](#)
IPSec [161](#)

algorithms [180](#)
architecture [180](#)
NAT [180](#)
see also VPN

K

keep alive [185](#)

L

LAN [101](#)
 client list [108](#)
 DHCP [102, 107, 112](#)
 DNS [102, 107, 112](#)
 IGMP [102, 115](#)
 IP address [102, 103, 113](#)
 IP alias [109](#)
 configuration [110](#)
 MAC address [108](#)
 multicast [102, 105, 114](#)
 NetBIOS [105](#)
 packet filter [105](#)
 RIP [102, 105, 110, 114](#)
 status [52](#)
 subnet mask [102, 103, 113](#)
LEDs [40](#)
limitations
 FTP [285](#)
Local Area Network, see LAN
login
 passwords [44](#)
Login screen [44](#)
logs [269](#)
 alerts [269](#)
 e-mail [272](#)
 error messages [273](#)
 example [273](#)
 firewalls [143](#)
 schedules [272](#)
 settings [271](#)

M

MAC address [108](#)

management VLAN [213](#)

managing the device

- good habits [40](#)
- using FTP. See FTP.
- using SMT. See SMT.
- using SNMP. See SNMP.
- using Telnet. See command interface.
- using the command interface. See command interface.
- using the web configurator. See web configurator.
- using TR-069. See TR-069.

mapping address [123](#)

- rules [125](#)
- types [125](#), [126](#), [130](#)

Maximum Burst Size, see MBS

maximum incomplete [148](#)

Maximum Transmission Unit, see MTU

MBS [84](#), [91](#), [98](#)

MD5 fingerprint [199](#)

metric [96](#)

- and policy route [97](#)
- and pre-defined priority [96](#)

monitor, QoS [230](#)

MTU [85](#), [91](#)

multicast [76](#), [84](#), [90](#), [102](#), [105](#), [114](#)

- IGMP Internet Group Multicast Protocol, see IGMP

multiplexing [79](#), [88](#), [95](#)

- LLC-based [95](#)
- VC-based [95](#)

my IP address [162](#)

N

nailed-up connection [80](#), [89](#), [96](#)

NAT [89](#), [117](#), [118](#), [127](#), [128](#), [471](#)

- activation [119](#)
- address mapping [123](#)
 - rules [125](#)
 - types [125](#), [126](#), [130](#)
- and filter set [369](#)
- applications [130](#)

- IP alias [130](#)
- default server IP address [120](#), [122](#)
- example [129](#)
- examples [346](#)
- global [128](#)
- IGA [128](#)
- ILA [128](#)
- inside [128](#)
- IPSec [180](#)
- local [128](#)
- outside [128](#)
- P2P [119](#)
- port forwarding [118](#), [120](#)
 - activation [123](#)
 - configuration [121](#)
 - example [121](#)
 - rules [122](#)
- remote management [241](#)
- SIP ALG [127](#)
 - activation [127](#)
- SUA [118](#), [119](#)
- traversal [181](#)

negotiation mode [185](#)

NetBIOS [105](#)

Network Address Translation

- see NAT

Network Address Translation, see NAT

Network Basic Input/Output System

O

outside header [183](#)

P

P2P [119](#), [147](#)

packet direction [139](#)

packet filter

- LAN [105](#)
- WAN [85](#), [91](#)

packet statistics [55](#)

Packet Transfer Mode [76](#)

passthrough, PPPoE [84](#)

passwords [44](#)

- administrator [265](#)
- users [265](#)
- PCR [84](#), [91](#), [98](#)
- Peak Cell Rate, see PCR
- PEM [199](#)
- point-to-point connections [38](#), [67](#), [70](#)
 - procedure [67](#), [70](#)
- policy route
 - and metric [97](#)
- port forwarding [118](#), [120](#)
 - activation [123](#)
 - configuration [121](#)
 - example [121](#)
 - rules [122](#)
- PPPoA [79](#), [88](#), [94](#)
- PPPoE [79](#), [88](#), [94](#)
 - passthrough [84](#)
- pre-shared key [188](#)
- private IP address [113](#)
- probing, firewalls [134](#)
- product registration [480](#)
- PTM [76](#)
- public-private key pairs [200](#)
- PVC [208](#)
- PVID [216](#)

Q

- QoS [217](#)
 - 802.1Q tags [228](#), [231](#)
 - activation [223](#)
 - bandwidth [223](#)
 - classifiers [224](#)
 - activation [224](#)
 - configuration [226](#)
 - creation [224](#)
 - priority [227](#)
 - CoS [218](#)
 - DiffServ [232](#)
 - DSCP [227](#), [229](#), [232](#)
 - example [219](#)
 - FTP [229](#)
 - IP precedence [231](#)
 - monitor [230](#)
 - priority queue [232](#)

- remote node [229](#)
- routing policy [227](#)
- SIP [229](#)
- Quality of Service, see QoS

R

- registration
 - product [480](#)
- related documentation [3](#)
- remote management [239](#)
 - DNS [248](#)
 - FTP [243](#)
 - ICMP [249](#)
 - limitations [240](#), [409](#)
 - NAT [241](#)
 - SNMP [244](#)
 - configuration [247](#)
 - Telnet [242](#)
 - WWW [241](#)
- remote node [229](#), [325](#)
 - and filter set [330](#)
- reset [295](#)
- restart [295](#)
- restoring configuration [285](#), [293](#)
- restrictions
 - FTP [285](#)
- RFC 1483 [79](#), [88](#), [94](#)
- RIP [83](#), [90](#), [102](#), [105](#), [110](#), [114](#)
- Routing Information Protocol, see RIP
- routing policy [227](#)
- rules, port forwarding [122](#)

S

- safety warnings [8](#)
- schedule set [411](#)
- schedules
 - content filtering [159](#)
 - firewalls [143](#)
 - logs [272](#)
- SCR [84](#), [91](#), [98](#)
- secure gateway address [162](#)

- security
 - network [150](#)
 - security associations, see VPN
 - Security Parameter Index [174](#)
 - Select Mode screen [45](#)
 - Session Initiation Protocol, see SIP
 - setup [293](#)
 - classifiers [226](#)
 - DHCP [107](#)
 - firewalls [138, 142, 147](#)
 - IP alias [110](#)
 - logs [271](#)
 - port forwarding [121](#)
 - SNMP [247](#)
 - static route [205](#)
 - WAN [78](#)
 - wizard [60](#)
 - SHA1 fingerprint [199](#)
 - shaping traffic [98, 99](#)
 - Simple Network Management Protocol, see SNMP
 - Single User Account, see SUA
 - SIP ALG [127, 229](#)
 - activation [127](#)
 - SMT [39, 301](#)
 - accessing [301](#)
 - menu items [302](#)
 - navigation [305](#)
 - SNMP [39, 244](#)
 - configuration [247](#)
 - specifications [421](#)
 - SPI [174](#)
 - static route [203](#)
 - activation [204](#)
 - configuration [205](#)
 - example [203](#)
 - status [46, 51, 53](#)
 - Any IP [54](#)
 - ATM [299](#)
 - DSL connections [300](#)
 - firewalls [52](#)
 - firmware version [52](#)
 - LAN [52](#)
 - packet statistics [55](#)
 - WAN [52](#)
 - SUA [118, 119](#)
 - subnet [463](#)
 - subnet mask [102, 113, 464](#)
 - subnetting [466](#)
 - Sustain Cell Rate, see SCR
 - syntax conventions [6](#)
 - system [264](#)
 - backing up configuration [289](#)
 - backup configuration [288](#)
 - firmware [284, 291](#)
 - upgrading [286](#)
 - version [52](#)
 - name [265](#)
 - passwords [44](#)
 - administrator [265](#)
 - users [265](#)
 - restoring configuration [285](#)
 - status [46, 51](#)
 - firewalls [52](#)
 - LAN [52](#)
 - WAN [52](#)
 - time [266](#)
 - System Management Terminal
 - see SMT
 - System Management Terminal. See SMT.
- ## T
- tagging frames [208, 215](#)
 - Telnet [242](#)
 - TFTP [289](#)
 - backing up configuration [289](#)
 - for backing up configuration file [391](#)
 - for upgrading firmware [399](#)
 - upgrading firmware [287](#)
 - three-way handshake [145](#)
 - thresholds
 - DoS [134, 145, 146, 147](#)
 - P2P [147](#)
 - time [266](#)
 - TR-069 [39](#)
 - trademarks [477](#)
 - traffic priority [207, 216](#)
 - traffic redirect [93, 97](#)
 - and IP alias [97](#)
 - and triangle route [97](#)
 - traffic shaping [98](#)

- example [99](#)
- transport mode [183](#)
- triangle route [139](#), [151](#), [152](#)
 - and traffic redirect [97](#)
 - solutions [152](#)
- trusted CA [195](#), [198](#)
 - algorithm [199](#)
 - exporting [199](#)
 - importing [196](#)
 - MD5 fingerprint [199](#)
 - PEM [199](#)
 - SHA1 fingerprint [199](#)
- tunnel mode [183](#)

U

- UBR [84](#), [90](#), [100](#)
- unicast [76](#)
- Universal Plug and Play, see UPnP
- upgrading firmware [286](#), [291](#)
- UPnP [251](#)
 - activation [253](#)
 - cautions [252](#)
 - example [253](#)
 - installation [253](#)
 - NAT traversal [251](#)
- URL [155](#)
- using console port [400](#)

V

- VBR [99](#)
- VBR-nRT [84](#), [90](#), [99](#)
- VBR-RT [84](#), [90](#), [99](#)
- VCI [79](#), [88](#), [95](#)
- Virtual Channel Identifier, see VCI
- Virtual Local Area Network, see VLAN
- Virtual Path Identifier, see VPI
- Virtual Private Network, see VPN
- VLAN [207](#)
 - 802.1P priority [207](#), [216](#)
 - activation [213](#)
 - example [209](#)

- group settings [214](#)
- management group [213](#)
- port settings [215](#)
- PVC [208](#)
- PVID [216](#)
- tagging frames [208](#), [215](#)
- VPI [79](#), [88](#), [95](#)
- VPN [161](#)
 - established in two phases [162](#)
 - IPSec [161](#)
 - security associations (SA) [162](#)
 - see also IKE SA, IPSec SA

W

- wall-mounting [427](#)
- WAN [75](#)
 - ATM QoS [84](#), [90](#), [99](#)
 - DNS [80](#)
 - encapsulation [76](#), [79](#), [88](#)
 - IGMP [77](#)
 - IP address [76](#), [80](#), [88](#), [95](#)
 - mode [79](#), [87](#)
 - modulation [81](#)
 - MTU [85](#), [91](#)
 - multicast [76](#), [84](#), [90](#)
 - multiplexing [79](#), [88](#), [95](#)
 - nailed-up connection [80](#), [89](#), [96](#)
 - NAT [89](#)
 - packet filter [85](#), [91](#)
 - RIP [83](#), [90](#)
 - setup [78](#)
 - status [52](#)
 - traffic shaping [98](#)
 - example [99](#)
 - VCI [79](#), [88](#), [95](#)
 - VPI [79](#), [88](#), [95](#)
- warranty [479](#)
 - note [479](#)
- web configurator [39](#), [43](#)
 - accessing [43](#)
 - minimum requirements [43](#)
 - passwords [44](#)
- Wide Area Network, see WAN
- wizard [57](#)
 - configuration [60](#)

