



YAMAHA

**TW200N
TW200NC**

**SUPPLEMENTARY
SERVICE MANUAL**

FOREWORD

This Supplementary Service Manual has been prepared to introduce new service and data for the TW200EN/TW200ENC. For complete service information procedures it is necessary to use this Supplementary Service Manual together with the following manual.

TW200T/TC '87 SERVICE MANUAL: LIT-11616-05-93 (2JX-28197-10)
TW200EU/EUC '88 SUPPLEMENTARY SERVICE MANUAL: LIT-11616-06-26 (2YG-28197-10)

**TW200N/TW200NC
SUPPLEMENTARY
SERVICE MANUAL**

© 2000 by Yamaha Motor Corporation, U.S.A.

First edition, November 2000

All rights reserved.

**Any reproduction or unauthorized use
without the written permission of
Yamaha Motor Corporation, U.S.A.
is expressly prohibited.**

Printed in U.S.A.

P/N LIT-11616-14-43

NOTICE

This manual was produced by the Yamaha Motor Company, Ltd. primarily for use by Yamaha dealers and their qualified mechanics. It is not possible to include all the knowledge of a mechanic in one manual. Therefore, anyone who uses this book to perform maintenance and repairs on Yamaha vehicles should have a basic understanding of mechanics and the techniques to repair these types of vehicles. Repair and maintenance work attempted by anyone without this knowledge is likely to render the vehicle unsafe and unfit for use.

This model has been designed and manufactured to perform within certain specifications in regard to performance and emissions. Proper service with the correct tools is necessary to ensure that the vehicle will operate as designed. If there is any question about a service procedure, it is imperative that you contact a Yamaha dealer for any service information changes that apply to this model. This policy is intended to provide the customer with the most satisfaction from his vehicle and to conform to federal environmental quality objectives.

Yamaha Motor Company, Ltd. is continually striving to improve all of its models. Modifications and significant changes in specifications or procedures will be forwarded to all authorized Yamaha dealers and will appear in future editions of this manual where applicable.

NOTE:

- This Service Manual contains information regarding periodic maintenance to the emission control system. Please read this material carefully.
 - Designs and specifications are subject to change without notice.
-

IMPORTANT MANUAL INFORMATION

Particularly important information is distinguished in this manual by the following.



The Safety Alert Symbol means ATTENTION! BECOME ALERT! YOUR SAFETY IS INVOLVED!

⚠ WARNING

Failure to follow WARNING instructions could result in severe injury or death to the motorcycle operator, a bystander or a person checking or repairing the motorcycle.

CAUTION:

A CAUTION indicates special precautions that must be taken to avoid damage to the motorcycle.

NOTE:

A NOTE provides key information to make procedures easier or clearer.

HOW TO USE THIS MANUAL

This manual is intended as a handy, easy-to-read reference book for the mechanic. Comprehensive explanations of all installation, removal, disassembly, assembly, repair and check procedures are laid out with the individual steps in sequential order.

- ① The manual is divided into chapters. An abbreviation and symbol in the upper right corner of each page indicate the current chapter. Refer to "SYMBOLS".
- ② Each chapter is divided into sections. The current section title is shown at the top of each page, except in chapter 3 ("PERIODIC CHECKS AND ADJUSTMENTS"), where the sub-section title(s) appears.
- ③ Sub-section titles appear in smaller print than the section title.
- ④ To help identify parts and clarify procedure steps, there are exploded diagrams at the start of each removal and disassembly section.
- ⑤ Numbers are given in the order of the jobs in the exploded diagram. A circled number indicates a disassembly step.
- ⑥ Symbols indicate parts to be lubricated or replaced. Refer to "SYMBOLS".
- ⑦ A job instruction chart accompanies the exploded diagram, providing the order of jobs, names of parts, notes in jobs, etc.
- ⑧ Jobs requiring more information (such as special tools and technical data) are described sequentially.

②

①

CYLINDER HEAD ENG

CYLINDER HEAD ENG

CYLINDER HEAD ENGINE

CHECKING THE TIMING CHAIN TENSIONER

1. Check:

- timing chain tensioner
- Cracks/damage/rough movement → Replace.

a. Lightly press the timing chain tensioner rod into the timing chain tensioner housing by hand.

NOTE:

While pressing the timing chain tensioner rod, wind it clockwise with a thin screwdriver ① until it stops.

b. Remove the screwdriver and slowly release the timing chain tensioner rod.

c. Make sure that the timing chain tensioner rod comes out of the timing chain tensioner housing smoothly. If there is rough movement, replace the timing chain tensioner.

INSTALLING THE TIMING CHAIN TENSIONER

TENSIONER

1. Install:

- timing chain tensioner

a. Lightly press the timing chain tensioner rod into the timing chain tensioner housing by hand.

b. While pressing the timing chain tensioner rod, wind it clockwise with a thin screwdriver ① until it stops.

c. With the screwdriver still inserted into the timing chain tensioner, install the timing chain tensioner ② and gasket onto the cylinder block. Then, tighten the timing chain tensioner bolts ③ to the specified torque.

WARNING

Always use a new gasket.

Timing chain tensioner bolt
10 Nm (1.0 m · kg, 7.2 ft · lb)

















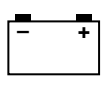

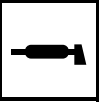

d. Remove the screwdriver, make sure that the timing chain tensioner rod releases, and tighten the cap bolt ②.

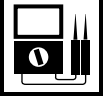
⑦

Order	Job/Part	Qty	Remarks
	Removing the cylinder head		
	Carburetor		Remove the parts in the order listed. Refer to "CARBURETOR".
	Fuel tank		
	Exhaust pipe		
1	Resonator hose	1	Disconnect.
2	Carburetor joint	1	
3	Timing chain tensioner cap bolt	1	
4	Timing chain tensioner	1	Refer to "INSTALLING THE TIMING CHAIN TENSIONER".
5	Gasket	1	
6	Camshaft sprocket cover/O-ring	1/1	
7	Camshaft sprocket	1	
8	Cylinder head	1	
9	Dowel pin	3	
10	Gasket	1	
			For installation, reverse the removal procedure.

- 28 -

- 29 -

① GEN INFO 	② SPEC 	
③ CHK ADJ 	④ ENG 	
⑤ CARB 	⑥ CHAS 	
⑦ ELEC 	⑧ TRBL SHTG ?	
⑨ 	⑩ 	
⑪ 	⑫ 	
⑬ 	⑭ 	
⑮ 	⑯ 	
⑰ 	⑱ 	⑲ 
⑳ 	㉑ 	㉒ 
㉓ 	㉔ New	

EAS00008

SYMBOLS

The following symbols are not relevant to every vehicle.

Symbols ① to ⑧ indicate the subject of each chapter.

- ① General information
- ② Specifications
- ③ Periodic checks and adjustments
- ④ Engine
- ⑤ Carburetion
- ⑥ Chassis
- ⑦ Electrical system
- ⑧ Troubleshooting

Symbols ⑨ to ⑯ indicate the following.

- ⑨ Serviceable with engine mounted
- ⑩ Filling fluid
- ⑪ Lubricant
- ⑫ Special tool
- ⑬ Tightening torque
- ⑭ Wear limit, clearance
- ⑮ Engine speed
- ⑯ Electrical data

Symbols ⑰ to ㉒ in the exploded diagrams indicate the types of lubricants and lubrication points.

- ⑰ Engine oil
- ⑱ Gear oil
- ⑲ Molybdenum disulfide oil
- ⑳ Wheel bearing grease
- ㉑ Lithium soap base grease
- ㉒ Molybdenum disulfide grease

Symbols ㉓ to ㉔ in the exploded diagrams indicate the following.

- ㉓ Apply locking agent (LOCTITE®)
- ㉔ Replace the part

CONTENTS

GENERAL INFORMATION	1
MOTORCYCLE IDENTIFICATION	1
VEHICLE IDENTIFICATION NUMBER	1
MODEL CODE	1
SPECIFICATIONS	2
GENERAL SPECIFICATIONS	2
MAINTENANCE SPECIFICATIONS	4
ENGINE	4
TIGHTENING TORQUESS	6
CHASSIS	7
TIGHTENING TORQUESS	8
ELECTRICAL	9
CABLE ROUTING	10
PERIODIC CHECKS AND ADJUSTMENTS	18
INTRODUCTION	18
PERIODIC MAINTENANCE CHART FOR EMISSION CONTROL SYSTEM	18
GENERAL MAINTENANCE AND LUBRICATION CHART	19
ENGINE	21
ADJUSTING THE THROTTLE CABLE FREE PLAY	21
CLEANING THE SPARK ARRESTER	22
CHASSIS	23
ADJUSTING THE FRONT BRAKE	23
CHECKING THE BRAKE FLUID LEVEL	24
CHECKING THE BRAKE PADS	25
CHECKING THE BRAKE HOSE	25
BLEEDING THE HYDRAULIC BRAKE SYSTEM	26
ENGINE	28
CYLINDER HEAD	28
CHECKING THE TIMING CHAIN TENSIONER	29
INSTALLING THE TIMING CHAIN TENSIONER	29
AC MAGNETO	30
STATOR COIL ASSEMBLY AND PICKUP COIL	30
AC MAGNETO	31
CARBURETION	32
CARBURETOR	32
DISASSEMBLING THE CARBURETOR	35
CHECKING THE CARBURETOR	35
ASSEMBLING THE CARBURETOR	37
INSTALLING THE CARBURETOR	38
MEASURING AND ADJUSTING THE FUEL LEVEL	39

CHASSIS	40
FRONT WHEEL AND BRAKE DISC	40
REMOVING THE FRONT WHEEL	42
CHECKING THE BRAKE DISC	42
INSTALLING THE FRONT WHEEL	44
FRONT BRAKE	46
FRONT BRAKE PADS	46
REPLACING THE FRONT BRAKE PADS	47
FRONT BRAKE MASTER CYLINDER	50
DISASSEMBLING THE FRONT BRAKE MASTER CYLINDER	52
CHECKING THE FRONT BRAKE MASTER CYLINDER	52
ASSEMBLING AND INSTALLING THE FRONT BRAKE MASTER CYLINDER	53
FRONT BRAKE CALIPER	55
DISASSEMBLING THE FRONT BRAKE CALIPER	57
CHECKING THE FRONT AND REAR BRAKE CALIPERS	58
ASSEMBLING AND INSTALLING THE FRONT BRAKE CALIPERS	59
FRONT FORK	62
STEERING HEAD	63
INSTALLING THE BEARING (RETAINER TYPE)	65
ELECTRICAL	66
ELECTRICAL COMPONENTS	66
SWITCHES	67
CHECKING SWITCH CONTINUITY	67
CHECKING THE SWITCHES	68
IGNITION SYSTEM	70
CIRCUIT DIAGRAM	70
TROUBLESHOOTING	71
ELECTRIC STARTING SYSTEM	75
CIRCUIT DIAGRAM	75
STARTING CIRCUIT CUT-OFF SYSTEM OPERATION	76
TROUBLESHOOTING	77
SIGNALING SYSTEM	81
CIRCUIT DIAGRAM	81
TROUBLESHOOTING	82
CHECKING THE SIGNALING SYSTEM	83

TW200EN/TW200ENC WIRING DIAGRAM

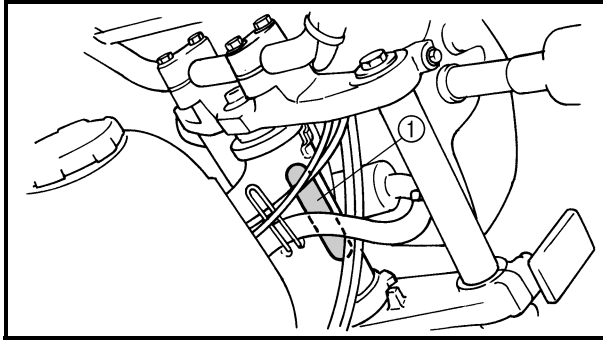

EAS00014

GENERAL INFORMATION MOTORCYCLE IDENTIFICATION

EAS00017

VEHICLE IDENTIFICATION NUMBER

The vehicle identification number ① is stamped into the right side of the steering head pipe.

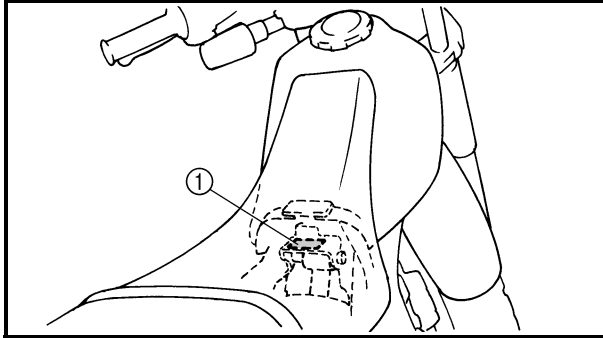

EAS00018

MODEL CODE

The model code label ① is affixed to the frame. This information will be needed to order spare parts.



SPECIFICATIONS

GENERAL SPECIFICATIONS

Model	TW200EN/TW200ENC
Model code number:	TW200EN: 5FY8 TW200ENC: 5FY9
Dimensions:	
Overall length	2,090 mm (82.3 in)
Overall width	820 mm (32.3 in)
Overall height	1,120 mm (44.1 in)
Seat height	790 mm (31.1 in)
Wheelbase	1,325 mm (52.2 in)
Minimum ground clearance	265 mm (10.4 in)
Engine:	
Engine type	Air cooled 4-stroke, SOHC
Cylinder arrangement	Forward inclined single cylinder
Displacement	196 cm ³ (11.96 cu.in)
Bore × stroke	67.0 × 55.7 mm (2.638 × 2.193 in)
Compression ratio	9.5 : 1
Compression pressure (standard)	900 kPa (9 kg/cm ² , 128 psi)
Starting system	Electric starter
Carburetor:	
Type/manufacturer	MV28/TEIKEI
Spark plug:	
Type/manufacturer	DR8EA (NGK), X24ESR-U (N.D.)
Gap	0.6 ~ 0.7 mm (0.024 ~ 0.028 in)
Chassis:	
Frame type	Diamond
Caster angle	25.8°
Trail	95 mm (3.74 in)
Tire:	
Type	With tube
Size (F)	130/80-18 66P TW31
Size (R)	180/80-14M/C 78P TW34
Wear Limit	<1.0 mm (0.04 in)>

GENERAL SPECIFICATIONS

SPEC



Model	TW200EN/TW200ENC	
Basic weight:	126 kg (278 lb)/(TW200EN), 127 kg (280 lb) (TW200ENC)	
With oil and full fuel tank	126 kg (278 lb)/(TW200EN), 127 kg (280 lb) (TW200ENC)	
Maximum load*	157 kg (346 lb)/(TW200EN), 156 kg (344 lb) (TW200ENC)	
Cold tire pressure:	Front	Rear
Up to 80 kg (176 lb) load*	125 kPa (1.25 kg/cm ² , 18 psi)	125 kPa (1.25 kg/cm ² , 18 psi)
80 kg (176 lb) ~ Maximum load*	150 kPa (1.5 kg/cm ² , 22 psi)	175 kPa (1.75 kg/cm ² , 25 psi)
Off-road riding	125 kPa (1.25 kg/cm ² , 18 psi)	125 kPa (1.25 kg/cm ² , 18 psi)
High speed riding	150 kPa (1.5 kg/cm ² , 22 psi)	175 kPa (1.75 kg/cm ² , 25 psi)
Brake:		
Front brake type	Single disc brake	
Operation	Right hand operation	
Rear brake type	Drum brake	
Operation	Right foot operation	
Shock absorber:		
Front shock absorber	Coil spring/oil damper	
Rear shock absorber	Gas and coil spring/oil damper	
Bulb wattage/quantity:		
Headlight	12 V, 60 W/55 W × 1	
Tail/brake light	12 V, 8 W/27 W × 2	
Front turn signal/position light	12 V, 27 W/8 W × 2	
Rear turn signal light	12 V, 27 W × 2	
Meter light	12 V, 3.4 W × 1	

* Load is the total weight of cargo, rider, passenger and accessories.



MAINTENANCE SPECIFICATIONS

ENGINE

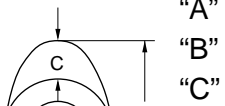
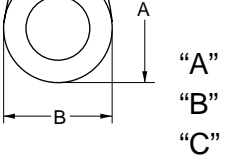
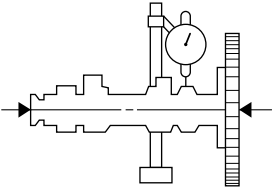
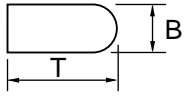
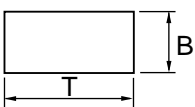
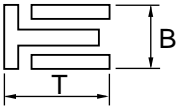
Model	TW200EN/TW200ENC
<p>Camshaft:</p> <p>Drive method</p> <p>Cam cap inside diameter</p> <p>Camshaft outside diameter</p> <p>Shaft-to-cap clearance</p> <p>Cam dimensions:</p> <p>Intake:</p>  <p>Exhaust:</p>  <p>Camshaft runout limit</p>  <p>Cam chain type/number of links</p> <p>Cam chain adjustment method</p>	<p>Chain drive (left)</p> <p>25.000 ~ 25.021 mm (0.984 ~ 0.985 in)</p> <p>24.96 ~ 24.98 mm (0.983 ~ 0.984 in)</p> <p>0.020 ~ 0.061 mm (0.0008 ~ 0.0024 in)</p> <p>36.538 ~ 36.638 mm (1.439 ~ 1.442 in)</p> <p>30.152 ~ 30.252 mm (1.187 ~ 1.191 in)</p> <p>6.588 mm (0.259 in)</p> <p>36.58 ~ 36.68 mm (1.440 ~ 1.444 in)</p> <p>30.266 ~ 30.366 mm (1.192 ~ 1.196 in)</p> <p>6.63 mm (0.261 in)</p> <p><0.03 mm (0.0012 in)></p> <p>DID 25SH/104 links</p> <p>Automatic</p>
<p>Piston ring:</p> <p>Sectional sketch:</p> <p>Top ring</p>  <p>2nd ring</p>  <p>Oil ring</p>  <p>End gap (Installed):</p> <p>Top ring</p> <p>2nd ring</p> <p>Oil ring</p> <p>Side clearance</p> <p>Top ring</p> <p>2nd ring</p>	<p>Barrel</p> <p>B = 1.2 mm (0.047 in)</p> <p>T = 2.7 mm (0.106 in)</p> <p>Taper</p> <p>B = 1.2 mm (0.047 in)</p> <p>T = 2.7 mm (0.106 in)</p> <p>Expander</p> <p>B = 2.5 mm (0.098 in)</p> <p>T = 2.8 mm (0.110 in)</p> <p>0.15 ~ 0.30 mm (0.006 ~ 0.012 in)</p> <p>0.15 ~ 0.35 mm (0.006 ~ 0.014 in)</p> <p>0.3 ~ 0.9 mm (0.012 ~ 0.035 in)</p> <p>0.03 ~ 0.07 mm (0.001 ~ 0.003 in)</p> <p>0.02 ~ 0.06 mm (0.001 ~ 0.002 in)</p>

MAINTENANCE SPECIFICATIONS

SPEC



Model	TW200EN/TW200ENC
Carburetor:	
ID mark	TW200EN: 5FY10 TW200ENC: 5FY00
Main jet (M.J.)	TW200EN: #126 TW200ENC: #128
Main air jet (M.A.J.)	1.2
Jet needle-clip/position (J.N.)	TW200EN: 5B21-1/1 TW200ENC: 5B21-1/3
Main nozzle (M.N.)	2.600
Pilot jet (P.J.)	#31
Pilot air jet (P.A.J.)	TW200EN: 0.95 TW200ENC: 1.0
Pilot outlet	0.8
Bypass	0.7
Valve seat (V.S.)	1.6
Starter jet (G.S1.)	0.6
(G.S2.)	0.8
Fuel level (above the line on the float chamber mating surface) (F.L.)	0.5 ~ 1.5 mm (0.02 ~ 0.06 in)
Float height	10 ~ 11 mm (0.39 ~ 0.43 in)
Engine idling speed	1,300 ~ 1,500 r/min
Vacuum pressure at idling speed	29.3 ~ 34.7 kPa (220 ~ 260 mmHg, 8.66 ~ 10.24 inHg) or more



TIGHTENING TORQUESS

Parts to be tightened	Part name	Thread size	Q'ty	Tightening torque			Remarks
				Nm	m·kg	ft·lb	
Cam sprocket cover	Bolt	M6	2	10	1.0	7.2	
Tappet cover	Bolt	M6	5	10	1.0	7.2	
Timing chain tensioner	Bolt	M6	2	10	1.0	7.2	
Oil filter cover	Bolt	M6	2	10	1.0	7.2	
Muffler protector	Screw	M6	4	7	0.7	5.1	
Crankcase	Bolt	M6	12	10	1.0	7.2	
Crankcase cover (left)	Bolt	M6	9	10	1.0	7.2	
Crankcase cover (right)	Bolt	M6	12	10	1.0	7.2	
Pickup coil lead holder	Bolt	M6	1	10	1.0	7.2	Apply LOCTITE®
Pickup coil	Bolt	M6	2	10	1.0	7.2	Apply LOCTITE®
Stator coil assembly	Bolt	M6	3	10	1.0	7.2	Apply LOCTITE®



CHASSIS

Model	TW200EN/TW200ENC
Steering system: Steering bearing type	Angular ball
Drive chain: Type/manufacturer Number of links Chain free play	428HG (I)/DAIDO 121 links + joint 35 ~ 60 mm (1.38 ~ 2.36 in)
Front brake: Brake type Disc outside diameter × thickness Max. deflection Brake pad lining thickness <Limit> Master cylinder inside diameter Caliper cylinder inside diameter Recommended fluid	Single-disc brake 220 × 3.5 mm (8.66 × 0.14 in) 0.15 mm (0.006 in) 5.3 mm (0.21 in) <0.8 mm (0.03 in)> 11 mm (0.43 in) 26.9 mm (1.06 in) + 22.2 mm (0.87 in) DOT4
Rear brake: Brake type Drum inside dia. <Limit> Lining thickness Front <Limit> Shoe spring free length	Drum brake (leading and trailing) 110 mm (4.33 in) <111 mm (4.37 in)> 4 mm (0.16 in) <2 mm (0.08 in)> 50.5 mm (1.99 in)
Brake lever and brake pedal: Brake lever free play (at lever end) Brake pedal free play (at pedal end) Brake pedal position	2 ~ 5 mm (0.08 ~ 0.20 in) 20 ~ 30 mm (0.8 ~ 1.2 in) 15 mm (0.6 in) (Vertical height below footrest top.)
Clutch lever free play (at lever end):	10 ~ 15 mm (0.39 ~ 0.59 in)

TIGHTENING TORQUESS

Parts to be tightened	Thread size	Tightening torque			Remarks
		Nm	m·kg	ft·lb	
Throttle cable and carburetor	M6 × 1.0	5	0.5	3.6	See NOTE.
Pivot shaft and frame	M12 × 1.25	83	8.3	60	
Rear shock absorber and frame	M10 × 1.25	56	5.6	41	
Drive chain case and swingarm	M5 × 0.8	5	0.5	3.6	
Handlebar holder upper and upper bracket	M8 × 1.25	20	2.0	14	
Steering shaft and ring nut	M25 × 1.0	18	1.8	13	
Front brake master cylinder and handlebar	M6 × 1.0	7	0.7	5.1	
Front wheel hub and brake disc	M6 × 1.0	13	1.3	9.4	
Front brake caliper bracket and outer tube	M10 × 1.25	30	3.0	22	
Front brake caliper and caliper bracket	M10 × 1.25	27	2.7	19	
Brake hose union bolt	M10 × 1.25	30	3.0	22	
Air bleeder screw	M7 × 1.0	6	0.6	4.3	
Passenger footrest and frame	M8 × 1.25	15	1.5	11	
Rear fender and cover	M6 × 1.0	5	0.5	3.6	

NOTE:

1. First, tighten the ring nut to approximately 38 Nm (3.8 m • kg, 27 ft • lb) with a torque wrench, then loosen the ring nut completely.
2. Retighten the ring nut to specification.



ELECTRICAL

Model	TW200EN/TW200ENC
C.D.I.: Magneto model/manufacture Pickup coil resistance (color) Source coil resistance (color) C.D.I. unit-model/manufacture	F5BT/YAMAHA 656 ~ 984 Ω at 20 °C (68 °F) (R-W) 624 ~ 936 Ω at 20 °C (68 °F) (Br-G) 5LB/YAMAHA
Ignition coil: Model/manufacture Minimum spark gap Primary winding resistance Secondary winding resistance	2JN/YAMAHA 6 mm (0.24 IN) or more at 500 r/min 0.18 ~ 0.28 Ω at 20 °C (68 °F) 6.3 ~ 9.5 kΩ at 20 °C (68 °F)
Charging system: Type Model/manufacture Charge coil resistance (color)	A.C. magneto generator 5FBT/YAMAHA 0.5 ~ 0.7 Ω at 20 °C (68 °F) (W-W)
Rectifier/regulator: Type Model/manufacture No load regulated voltage Capacity Withstand voltage	Semi conductor type SH629A-12/SHINDENGEN 14.1 ~ 14.9 V 10 A 200 V
Starter motor: Model/manufacture Output Armature coil resistance Brush overall length <Limit> Brush spring pressure <Limit> Commutator dia. <Limit> Mica undercut	5FY/YAMAHA 0.4 kW 0.017 ~ 0.021 Ω 10 mm (0.39 in) <3.5 mm (0.14 in)> 560 ~ 840 g (19.8 ~ 29.6 oz) <450 g (0.98 oz)> 22 mm (0.87 in) <21 mm (0.83 in)> 1.5 mm (0.06 in)
Flasher relay: Type Model/manufacture Self cancelling device Flasher frequency Wattage	Full transistor FE246BH/DENSO No. 75 ~ 95 cycle/min 27 W × 2 + 3.4 W
Circuit breaker: Type Amperage for individual circuit Main	Fuse 20 A



CABLE ROUTING

- ① Throttle cable
- ② Front brake light switch lead
- ③ Right handlebar switch lead
- ④ Clutch cable
- ⑤ Left handlebar switch lead
- ⑥ Clutch switch lead
- ⑦ Front turn signal/position light lead (left)
- ⑧ Main switch lead

- ⑨ Indicator lights lead
- ⑩ Speedometer cable
- ⑪ Meter light lead
- ⑫ Headlight coupler
- ⑬ Wire harness
- ⑭ Front turn signal/position light lead (right)
- ⑮ Brake hose

- Ⓐ Fasten the brake hose with a plastic locking tie to the brake hose grommet.
- Ⓑ Fasten the wire harness with a plastic locking tie.

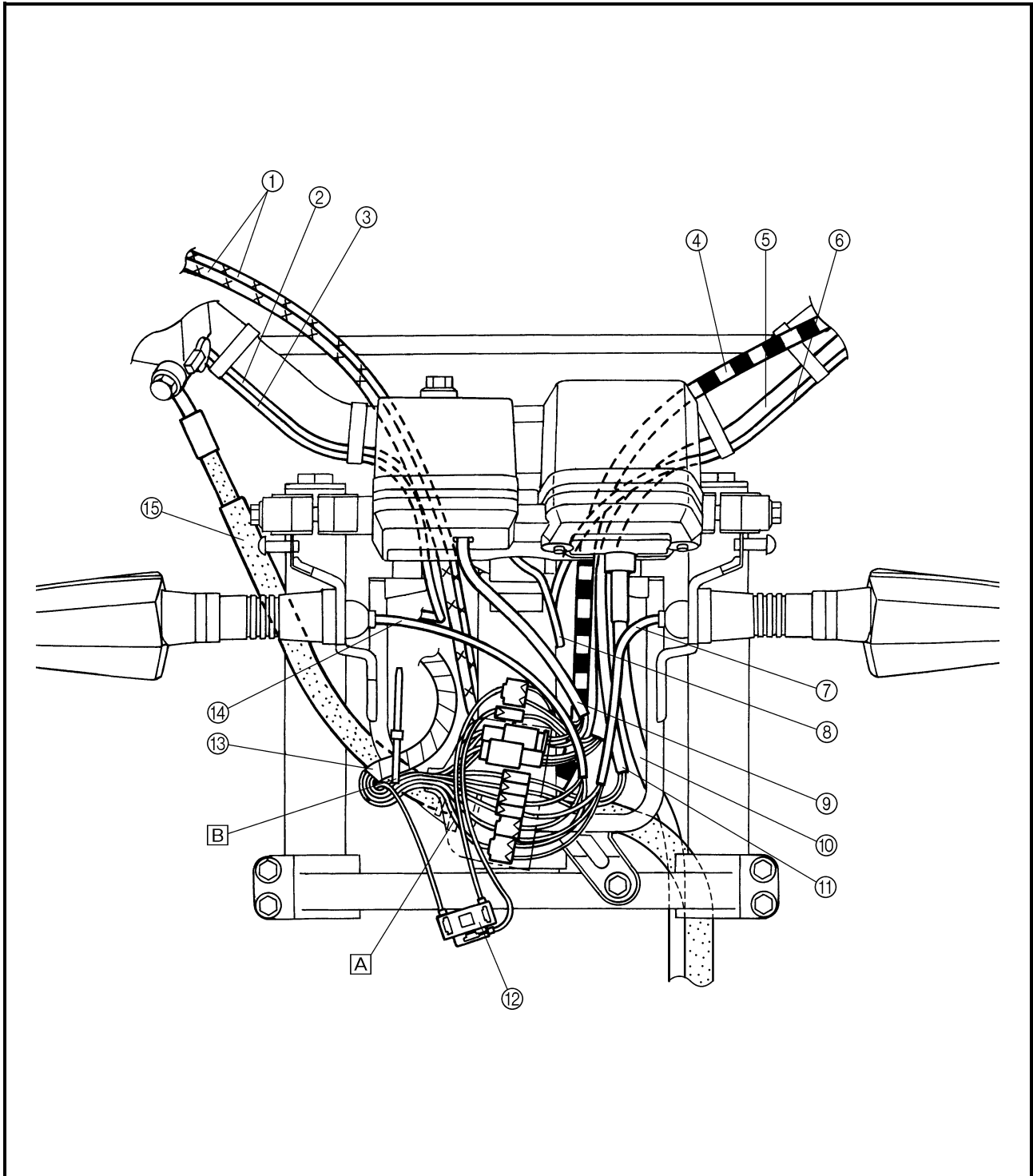



- ① Clutch cable
- ② Left handlebar switch lead
- ③ Clutch switch lead
- ④ Resonator hose
- ⑤ Main switch lead
- ⑥ Rectifier/regulator lead
- ⑦ Fuel hose
- ⑧ Brake hose
- ⑨ Speedometer cable
- ⑩ Horn lead

- A Fasten the resonator hose with a plastic band between the resonator hose protectors so that the fastener does not squeeze the hose.
- B Pass the canister hose through the guide of the frame. (for California)
- C Fasten the resonator hose with a plastic band in front of the resonator hose protector.
- D Fasten the rectifier/regulator lead and resonator hose with a plastic band between the resonator hose protectors so that the fastener does not squeeze the hose.
- E Fasten the brake hose with a plastic locking tie to the brake hose grommet.

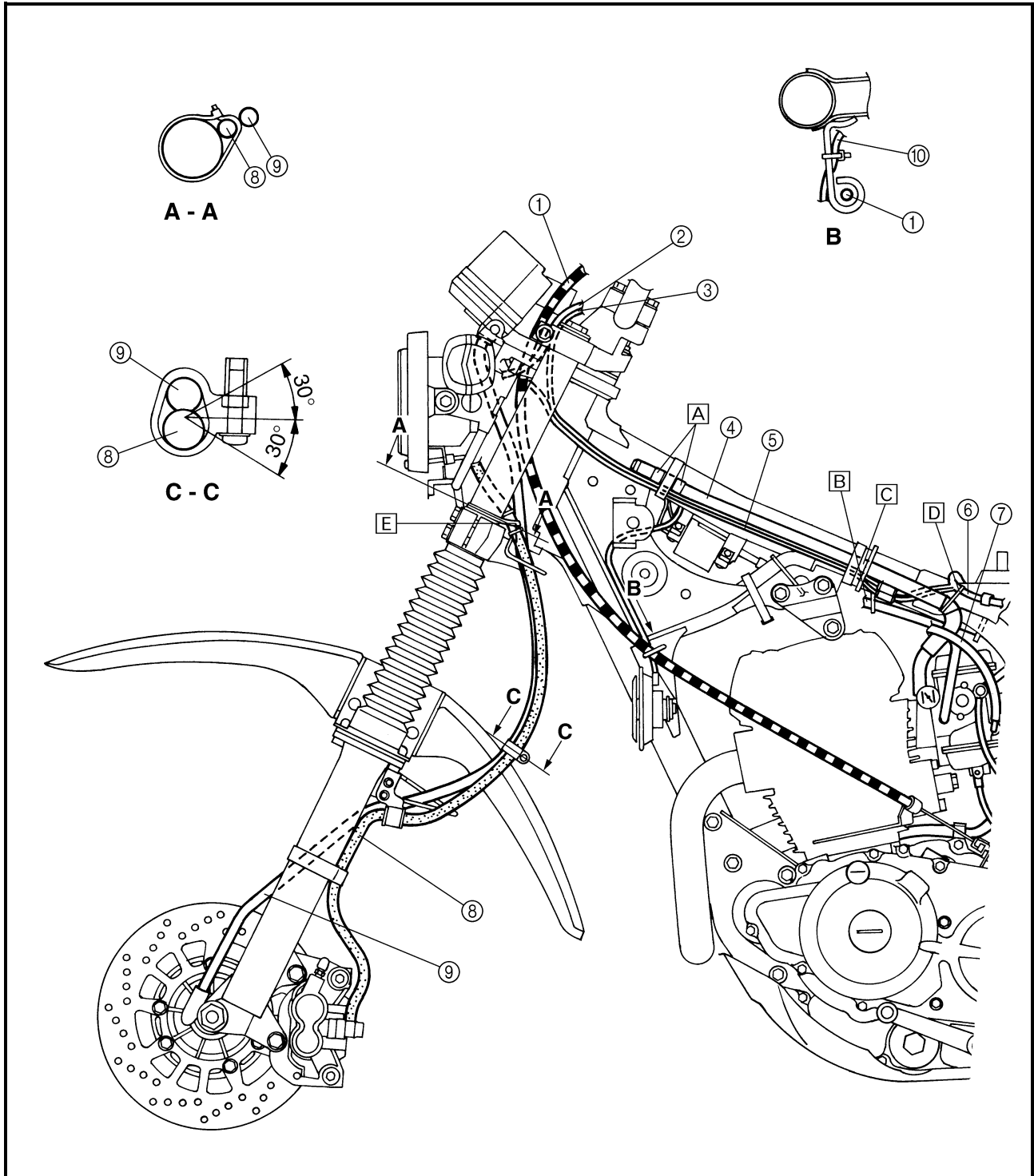



- ① Sidestand switch lead
- ② Crankcase breather hose
- ③ Battery negative terminal
- ④ Carburetor air vent hose
- ⑤ Carburetor overflow hose
- ⑥ AC magneto lead
- ⑦ Starter motor lead
- ⑧ Neutral switch lead

- Ⓐ Fasten the AC magneto leads with a plastic locking tie to the frame at the section where the frame starts to curve.
- Ⓑ Fasten the carburetor air vent hose, carburetor overflow hose, and neutral switch lead with a plastic clip.

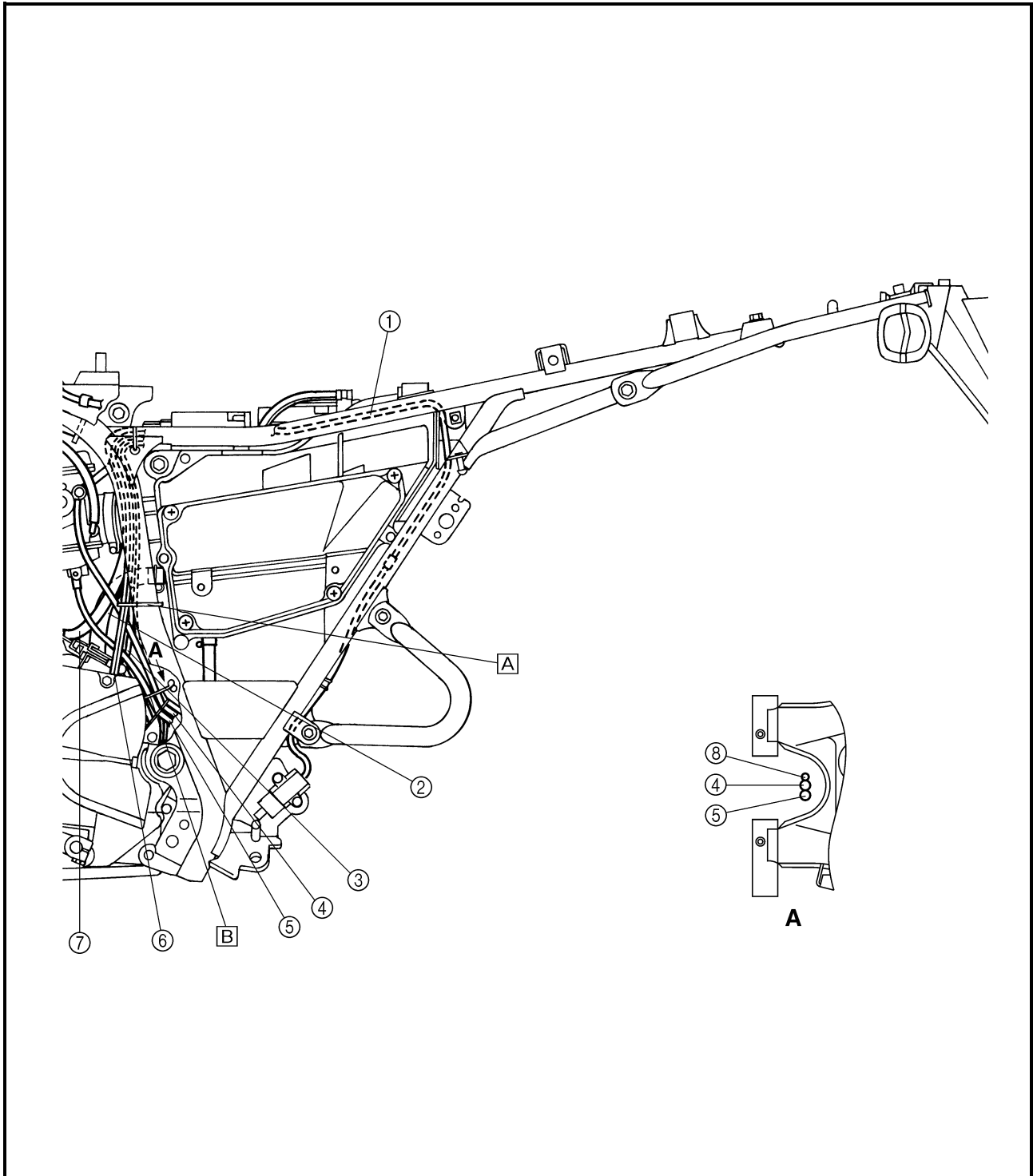



- ① Ignition coil
- ② Throttle cable
- ③ Horn lead
- ④ Canister hose (for California)
- ⑤ Canister (for California)
- ⑥ Spark plug
- ⑦ Starter motor lead

- A Fasten the wire harness, right handlebar switch lead, front brake light switch lead, clutch switch lead, main switch lead, and throttle cable with a plastic band.
- B Fasten the wire harness, right handlebar switch lead, front brake light switch lead, clutch switch lead, main switch lead, and resonator hose with a plastic band.
- C Fasten the throttle cable and canister hose with a plastic clip. Be sure to face the ends of the clip downward from the frame. (for California)
- D Fasten the throttle cable with a plastic locking tie through the hole in the frame bracket.

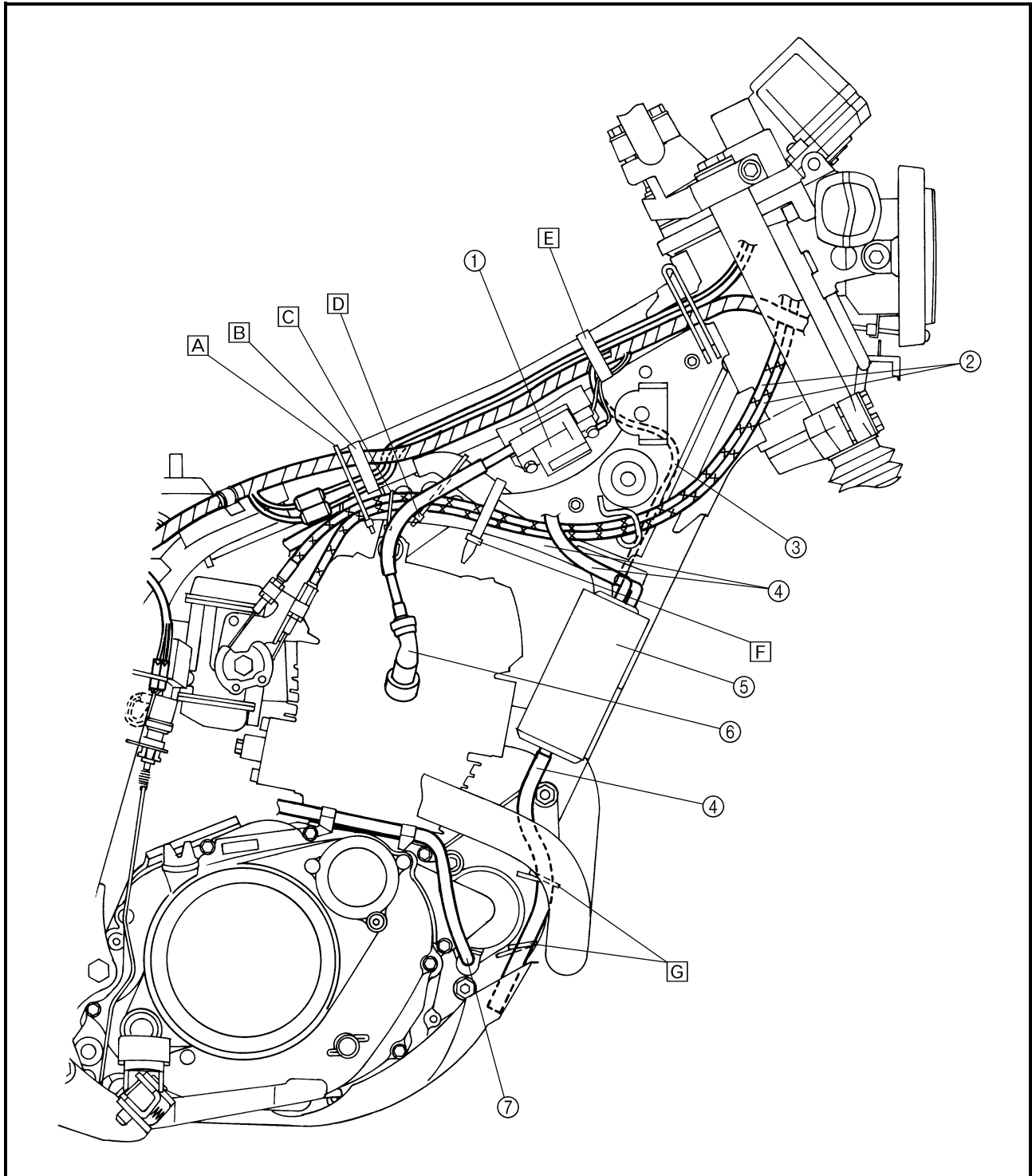



- E Fasten the wire harness, right handlebar switch lead, front brake light switch lead, clutch switch lead, main switch lead, resonator hose, ignition coil lead, ground lead, and horn lead with a plastic band.
- F Fasten the canister hose with a plastic band. (for California)
- G Pass the canister hose through the engine stay guide. (for California)

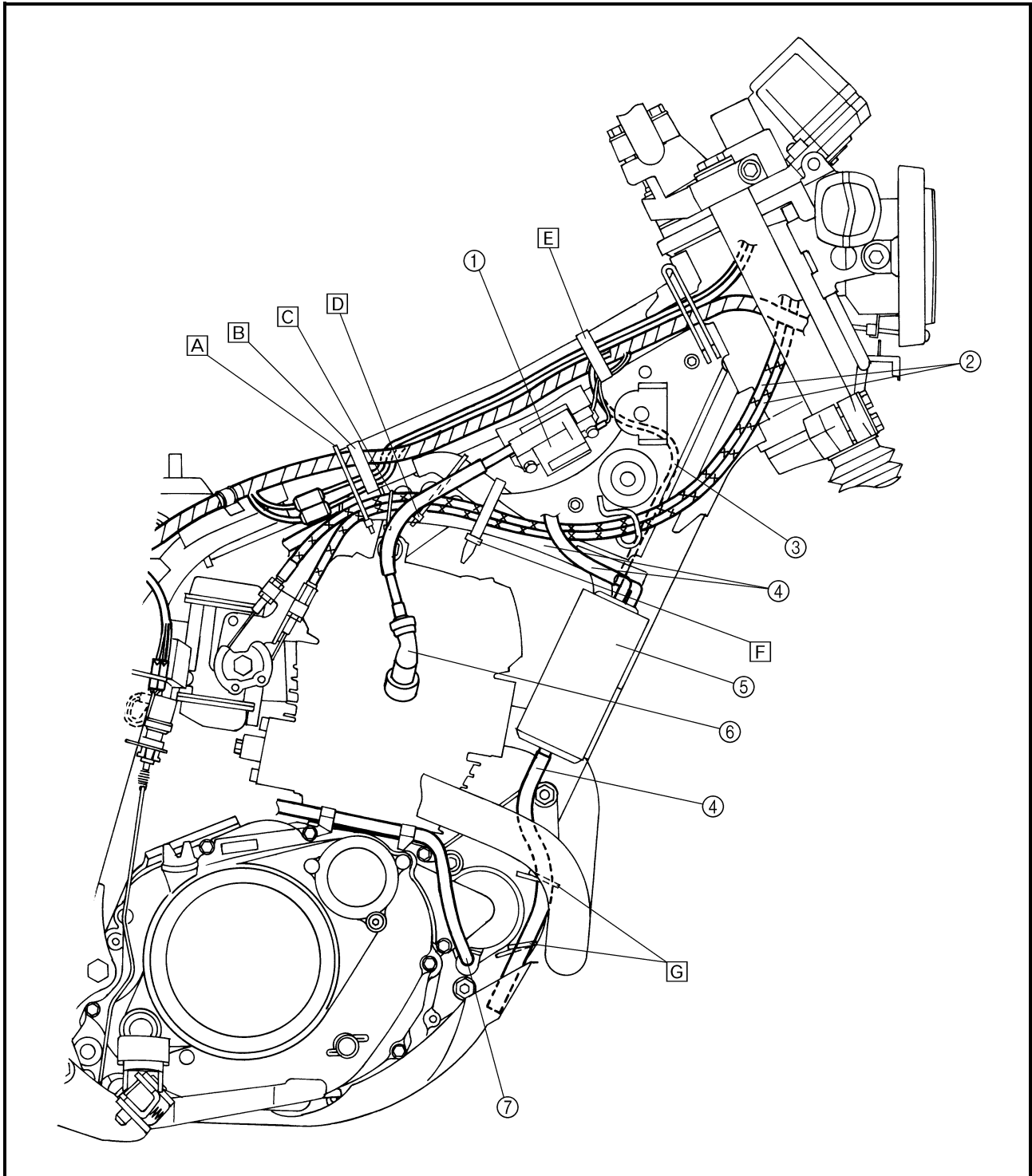



- ① Diode
- ② Battery positive lead
- ③ Starter relay
- ④ Starter motor lead
- ⑤ CDI unit
- ⑥ Wire harness
- ⑦ Turn signal relay

- [A] Fasten the wire harness with a plastic locking tie at the section just before the leads split.
- [B] Pass the battery breather hose inside the battery positive lead.
- [C] Pass the rear brake light switch lead in front of the frame so that it is not squeezed by the side cover and frame.
- [D] Fasten the rear brake light switch lead and turn signal relay lead with a plastic locking tie.
- [E] Face the rear brake light switch lead to the rear of the frame.
- [F] Pass the battery breather hose through the hose guide.
- [G] Pass the battery breather hose through the hole in the electrical components box.
- [H] Fasten the wire harness and diode with a plastic locking tie.

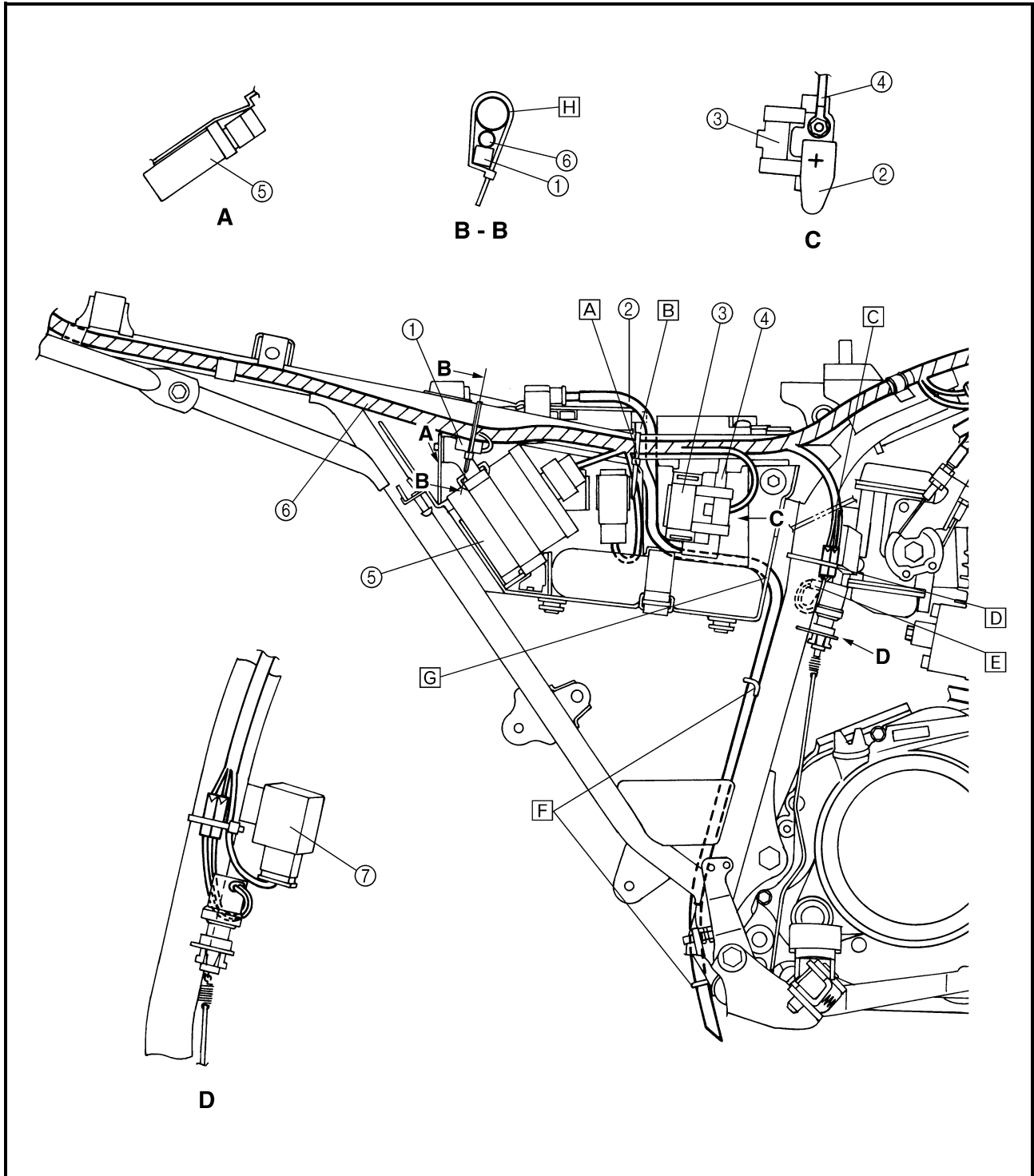



- ① Clutch switch lead
- ② Clutch cable
- ③ Brake hose
- ④ Throttle cable
- ⑤ Front brake light switch lead
- ⑥ Right handlebar switch lead
- ⑦ Starter motor lead
- ⑧ AC magneto lead
- ⑨ Rectifier/regulator
- ⑩ Battery negative lead
- ⑪ Neutral switch lead

- ⑫ Left handlebar switch lead

- [A] Fasten the right handlebar switch lead and front brake light switch lead with a plastic band.
- [B] Fasten the AC magneto leads, starter motor lead, neutral switch lead, and battery negative lead with a plastic locking tie by passing the tie through the hole in the frame bracket.

- [C] Fasten the left handlebar switch lead and clutch switch lead with a plastic band.

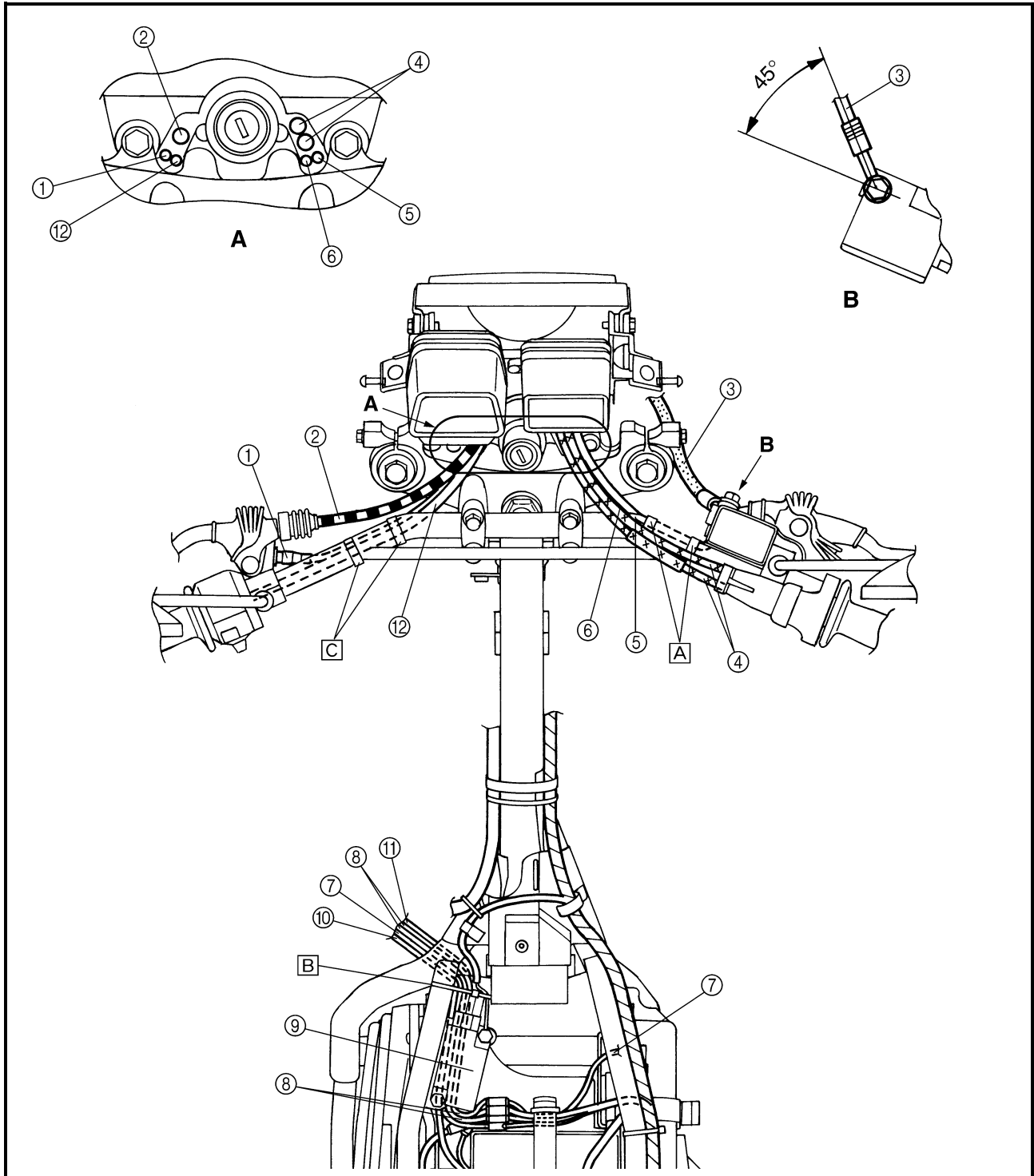



- ① Battery positive lead
- ② Rear turn signal light lead (right)
- ③ Tail/brake light lead
- ④ Rear turn signal light lead (left)
- ⑤ Sidestand switch lead
- ⑥ Battery negative lead
- ⑦ AC magneto lead
- ⑧ Neutral switch lead
- ⑨ Starter motor lead

- [A] Fasten the wire harness and rear turn signal light lead (right) with a plastic locking tie at the section behind the hook.
- [B] Fasten the rear turn signal light lead (left) with a plastic locking tie.

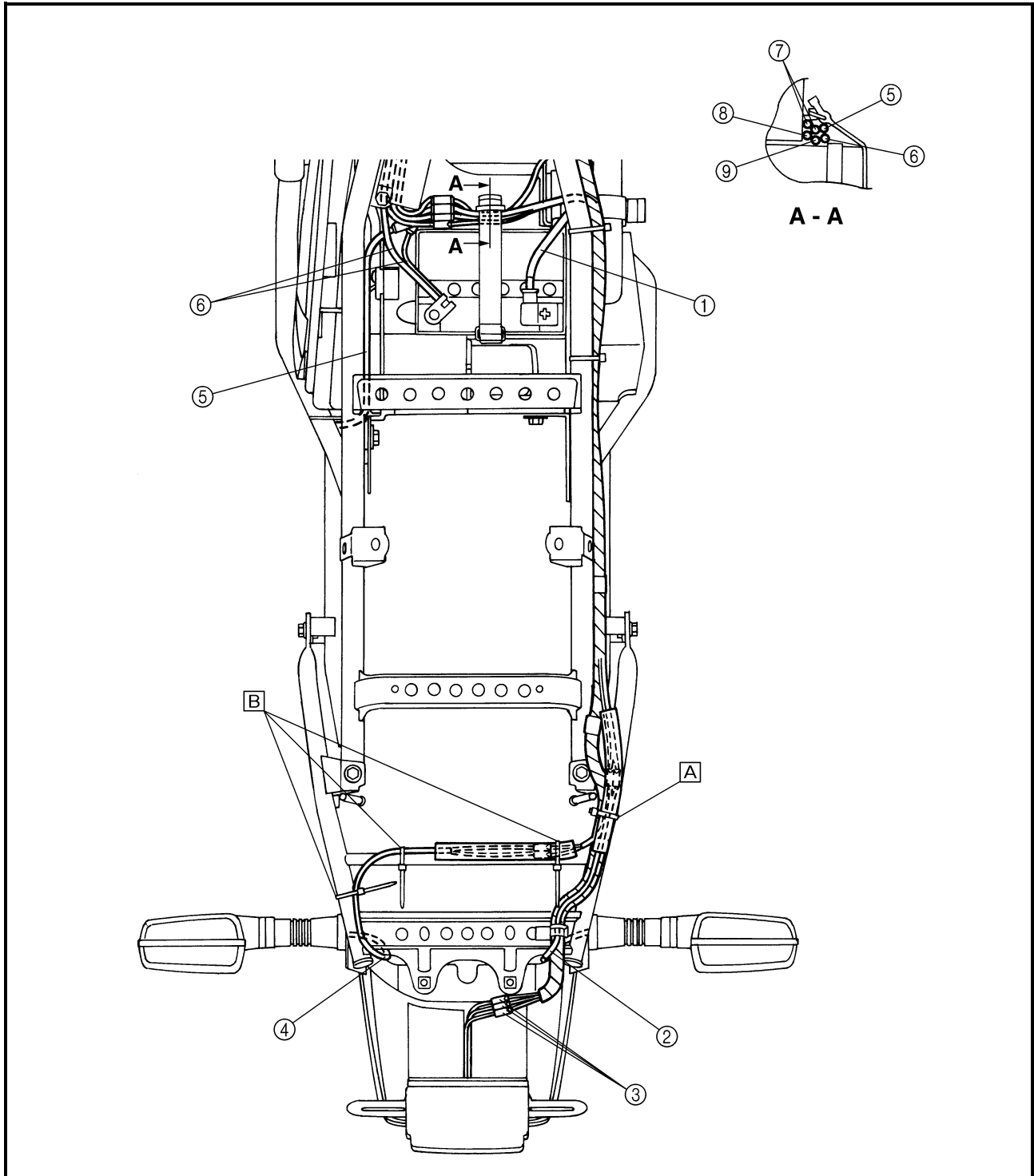

INTRODUCTION/PERIODIC MAINTENANCE CHART FOR EMISSION CONTROL SYSTEM



PERIODIC CHECKS AND ADJUSTMENTS

INTRODUCTION

This chapter includes all information necessary to perform recommended checks and adjustments. If followed, these preventive maintenance procedures will ensure more reliable vehicle operation, a longer service life and reduce the need for costly overhaul work. This information applies to vehicles already in service as well as to new vehicles that are being prepared for sale. All service technicians should be familiar with this entire chapter.

PERIODIC MAINTENANCE CHART FOR EMISSION CONTROL SYSTEM

No.	ITEM	ROUTINE	INITIAL	ODOMETER READINGS				
			600 mi (1,000 km) or 1 month	4,000 mi (6,000 km) or 6 month	7,000 mi (11,000 km) or 12 month	10,000 mi (16,000 km) or 18 month	13,000 mi (21,000 km) or 24 month	
1	* Valve clearance	<ul style="list-style-type: none"> Check and adjust valve clearance when engine is cold. 	√	√	√	√	√	
2	Spark plug	<ul style="list-style-type: none"> Check condition. Adjust gap and clean. Replace at 11,000 km (or 12 months) and thereafter every 10,000 km (or 12 months). 		√	Replace	√	Replace	
3	* Fuel line	<ul style="list-style-type: none"> Check fuel hose for crack or damage. Replace if necessary. 		√		√		
4	* Exhaust system	<ul style="list-style-type: none"> Check for leakage. Retighten if necessary. Replace gaskets if necessary. 		√	√	√	√	
5	Spark arrester	<ul style="list-style-type: none"> Clean. 		√	√	√	√	
6	* Idle speed	<ul style="list-style-type: none"> Check and adjust engine idle speed. Adjust cable free play. 		√	√	√	√	
7	* Evaporative emission control system**	<ul style="list-style-type: none"> Check control system for damage. Replace if necessary. 			√		√	

*: Since these items require special tools, data and technical skills, have a Yamaha dealer perform the service.

** : California type only.

NOTE:

From 16,000 mi (26,000 km) or 30 months, repeat the maintenance intervals starting from 4,000 mi (6,000 km) or 6 months.

GENERAL MAINTENANCE AND LUBRICATION CHART



GENERAL MAINTENANCE AND LUBRICATION CHART

No.	ITEM	ROUTINE	TYPE	INITIAL	ODOMETER READINGS				
				600 mi (1,000 km) or 1 month	4,000 mi (6,000 km) or 6 month	7,000 mi (11,000 km) or 12 month	10,000 mi (16,000 km) or 18 month	13,000 mi (21,000 km) or 24 month	
1	Engine oil	<ul style="list-style-type: none"> Warm-up engine before draining. 	1) Yamalube 4 (20 W 40) or SAE 20 W 40 type "SE/SF" motor oil. 2) Yamalube 4 (10 W 30) or SAE 10 W 30 type "SE/SF" motor oil.	√	√	√	√	√	
2	* Oil filter/strainer	<ul style="list-style-type: none"> Clean filter element and oil strainer. Replace oil filter and strainer if damaged. 	–	√		√		√	
3	* Air filter	<ul style="list-style-type: none"> Wet type filter must be washed and damped with oil. 	Yamaha foam air filter oil or other quality air filter oil.	√	√	√	√	√	
4	* Brake system	<ul style="list-style-type: none"> Adjust free play. Check fluid leakage. (Front) (see NOTE.) Correct if necessary. Replace pads if necessary. (Front) Replace shoes if necessary. (Rear) 	–	√	√	√	√	√	
5	* Clutch	<ul style="list-style-type: none"> Adjust free play. 	–	√	√	√	√	√	
6	Drive chain	<ul style="list-style-type: none"> Check chain condition. Adjust and lubricate chain thoroughly. 	Special O-ring chain lubricant	Every 300 mi (500 km)					
7	Control and meter cable	<ul style="list-style-type: none"> Apply chain lube thoroughly. 	Yamaha chain and cable lube or engine oil.	√	√	√	√	√	
8	* Rear arm pivot shaft	<ul style="list-style-type: none"> Apply until new grease shows. 	Lithium-soap-based grease. (all-purpose grease)		√	√	√	√	
9	Brake/clutch lever pivot shaft	<ul style="list-style-type: none"> Apply chain lube lightly. 	Lithium-soap-based grease. (all-purpose grease)		√	√	√	√	
10	Brake pedal and shift pedal shaft	<ul style="list-style-type: none"> Lubricate. Apply chain lube lightly 	Lithium-soap-based grease. (all-purpose grease)		√	√	√	√	
11	* Sidestand pivots	<ul style="list-style-type: none"> Check operation and lubricate. Apply chain lube lightly. 	Lithium-soap-based grease. (all-purpose grease)		√	√	√	√	
12	* Front fork	<ul style="list-style-type: none"> Check operation and leakage. 	–		√	√	√	√	
13	* Steering bearings	<ul style="list-style-type: none"> Check bearings assembly for looseness. Moderately repack every 10,000 mi (16,000 km) 	Medium weight wheel bearing grease.		√	√	Repack	√	
14	* Wheel bearings	<ul style="list-style-type: none"> Check bearings for smooth rotation. 	–		√	√	√	√	

GENERAL MAINTENANCE AND LUBRICATION CHART



No.	ITEM	ROUTINE	TYPE	INITIAL	ODOMETER READINGS				
				600 mi (1,000 km) or 1 month	4,000 mi (6,000 km) or 6 month	7,000 mi (11,000 km) or 12 month	10,000 mi (16,000 km) or 18 month	13,000 mi (21,000 km) or 24 month	
15	Battery	<ul style="list-style-type: none"> • Check specific gravity. • Check that the breather pipe is working properly. • Correct if necessary. 	–		√	√	√	√	
16	* Sidestand switch	<ul style="list-style-type: none"> • Check and clean or replace if necessary. 	–	√	√	√	√	√	

* Since these items require special tools, data and technical skills, have a Yamaha dealer perform the service.

NOTE:

1. The air filter element needs more frequent service if you are riding in unusually wet or dusty areas.
2. Hydraulic brake system
 - Replace the brake fluid after disassembling the master cylinder or caliper cylinder.
 - Check the brake fluid level and add fluid as required.
 - Replace the master cylinder and caliper cylinder oil seals every two years.
 - Replace the brake hoses every four years or if cracked or damaged.

ENGINE

ADJUSTING THE THROTTLE CABLE FREE PLAY

NOTE: _____
 Prior to adjusting the throttle cable free play, the engine idling speed should be adjusted properly.

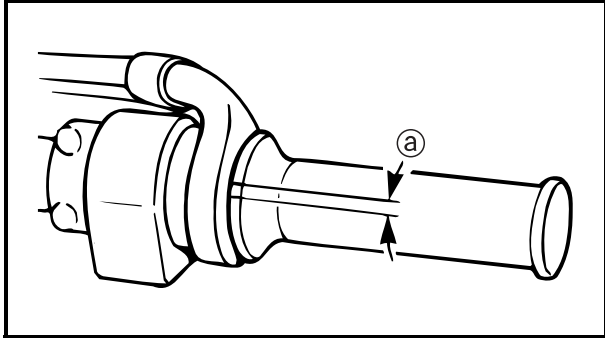

1. Measure:
 - throttle cable free play ①
 - Out of specification → Adjust.

**Throttle cable free play
 (at the flange of the throttle grip)
 3 ~ 5 mm (0.12 ~ 0.20 in)**

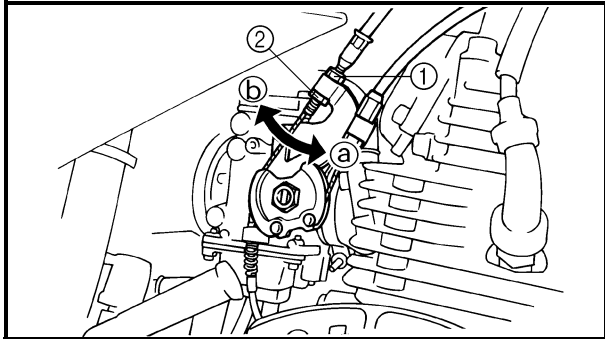

2. Adjust:
 - throttle cable free play



Carburetor side

- a. Loosen the locknut ①.
- b. Turn the adjusting nut ② in direction ③ or ④ until the specified throttle cable free play is obtained.

Direction ③	Throttle cable free play is increased.
Direction ④	Throttle cable free play is decreased.

- c. Tighten the locknut.

NOTE: _____
 If the specified throttle cable free play cannot be obtained on the carburetor side of the cable, use the adjusting nut on the handlebar side.

ADJUSTING THE THROTTLE CABLE FREE PLAY/ CLEANING THE SPARK ARRESTER

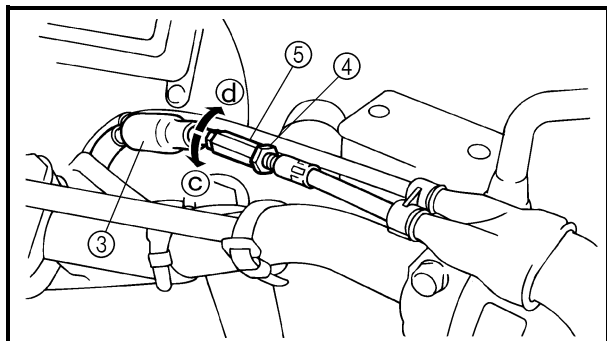

Handlebar side

- a. Slide back the rubber cover ③.
- b. Loosen the locknut ④.
- c. Turn the adjusting nut ⑤ in direction ㉞ or ㉟ until the specified throttle cable free play is obtained.

Direction ㉞	Throttle cable free play is increased.
Direction ㉟	Throttle cable free play is decreased.

- d. Tighten the locknut.

⚠ WARNING

After adjusting the throttle cable free play, start the engine and turn the handlebars to the right and to the left to ensure that this does not cause the engine idling speed to change.

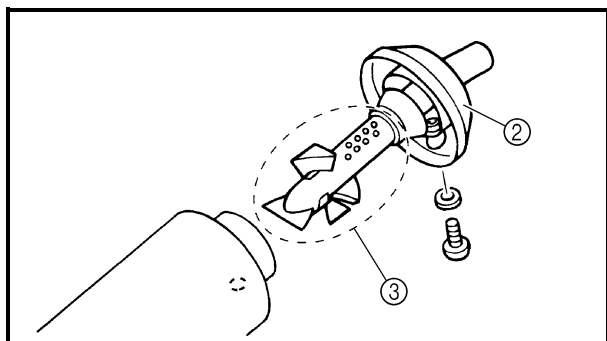
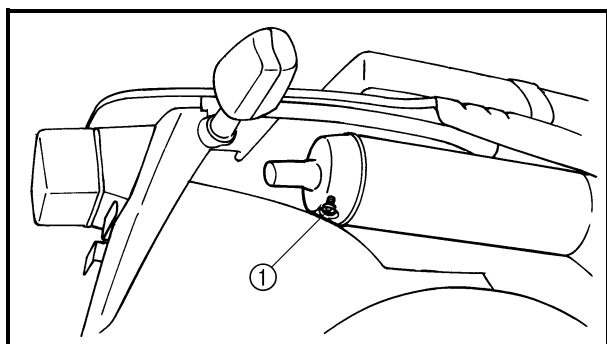

CLEANING THE SPARK ARRESTER

1. Clean:
 - Spark arrester



⚠ WARNING

- Do not start the engine when cleaning the exhaust system.
- Always let the exhaust system cool before performing this operation.

- a. Remove the screw ①.
- b. Remove the tail pipe ② by pulling it out of the muffler.
- c. Tap the tail pipe lightly, then use a wire brush to remove any carbon deposits from the spark arrester ③ portion of the tail pipe.
- d. Insert the tail pipe into the muffler and align the screw hole.
- e. Install the screw and tighten it.



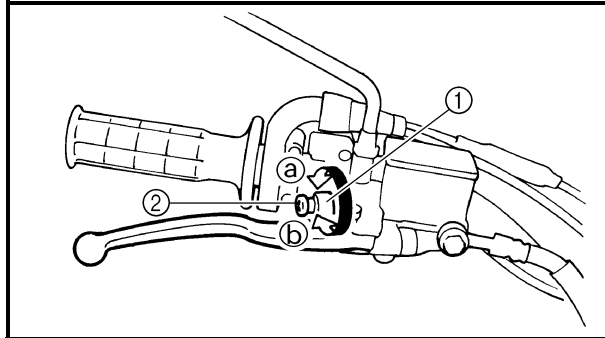
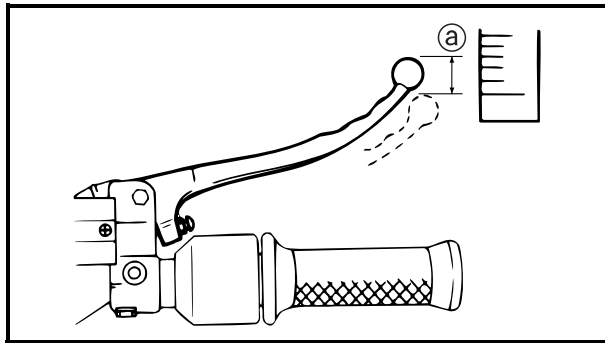

CHASSIS

ADJUSTING THE FRONT BRAKE

1. Check:
 - brake lever free play **a**
 Out of specification → Adjust.

	Brake lever free play (at the end of the brake lever) 2 ~ 5 mm (0.08 ~ 0.20 in)
---	--

2. Adjust:
 - brake lever free play



- a. Loosen the locknut **1**.
- b. Turn the adjusting bolt **2** in direction **a** or **b** until the specified brake lever free play is obtained.

Direction a	Brake lever free play is increased.
Direction b	Brake lever free play is decreased.

- c. Tighten the locknut.

⚠ WARNING

A soft or spongy feeling in the brake lever can indicate the presence of air in the brake system. Before the vehicle is operated, the air must be removed by bleeding the brake system. Air in the brake system will considerably reduce braking performance and could result in loss of control and possibly an accident. Therefore, check and, if necessary, bleed the brake system.

CAUTION:

After adjusting the brake lever free play, make sure there is no brake drag.



CHECKING THE BRAKE FLUID LEVEL

1. Stand the motorcycle on a level surface.

NOTE: _____

- Place the motorcycle on a suitable stand.
- Make sure that the motorcycle is upright.

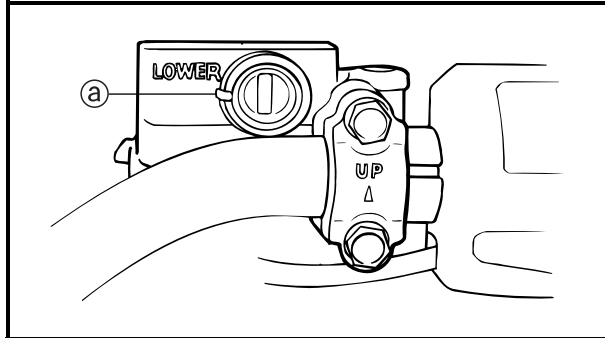

2. Check:

- brake fluid level

Below the minimum level mark (a) → Add the recommended brake fluid to the proper level.



⚠ WARNING _____

- Use only the designated brake fluid. Other brake fluids may cause the rubber seals to deteriorate, causing leakage and poor brake performance.
- Refill with the same type of brake fluid that is already in the system. Mixing brake fluids may result in a harmful chemical reaction, leading to poor brake performance.
- When refilling, be careful that water does not enter the brake fluid reservoir. Water will significantly lower the boiling point of the brake fluid and could cause vapor lock.

CAUTION: _____

Brake fluid may damage painted surfaces and plastic parts. Therefore, always clean up any spilt brake fluid immediately.

NOTE: _____

In order to ensure a correct reading of the brake fluid level, make sure that the top of the brake fluid reservoir is horizontal.

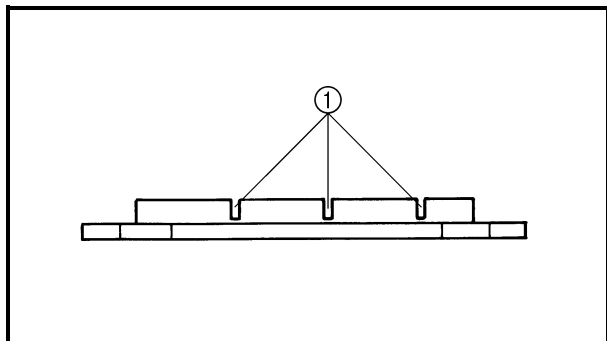

CHECKING THE BRAKE PADS

The following procedure applies to all of the brake pads.

1. Operate the brake.
2. Check:
 - front brake pad
Wear indicator groove ① almost disappeared → Replace the brake pads as a set. Refer to “REPLACING THE FRONT BRAKE PADS”.

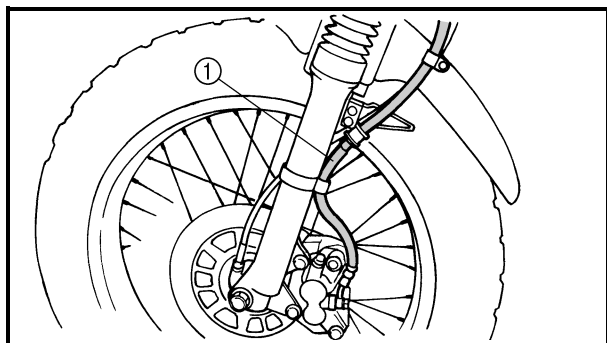

CHECKING THE BRAKE HOSE

The following procedure applies to all of the brake hose and brake hose clamps.

1. Check:
 - brake hose ①
Cracks/damage/wear → Replace.
2. Check:
 - brake hose clamp
Loose → Tighten the clamp bolt.
3. Hold the motorcycle upright and apply the brake several times.
4. Check:
 - brake hose
Brake fluid leakage → Replace the damaged hose.
Refer to “FRONT BRAKE”.

- h. Tighten the bleed screw and then release the brake lever.
- i. Repeat steps (e) to (h) until all of the air bubbles have disappeared from the brake fluid in the plastic hose.
- j. Tighten the bleed screw to specification.

	Bleed screw 6 Nm (0.6 m · kg, 4.3 ft · lb)
---	---

- k. Fill the brake fluid reservoir to the proper level with the recommended brake fluid. Refer to “CHECKING THE BRAKE FLUID LEVEL”.

⚠ WARNING

After bleeding the hydraulic brake system, check the brake operation.





CYLINDER HEAD



ENGINE

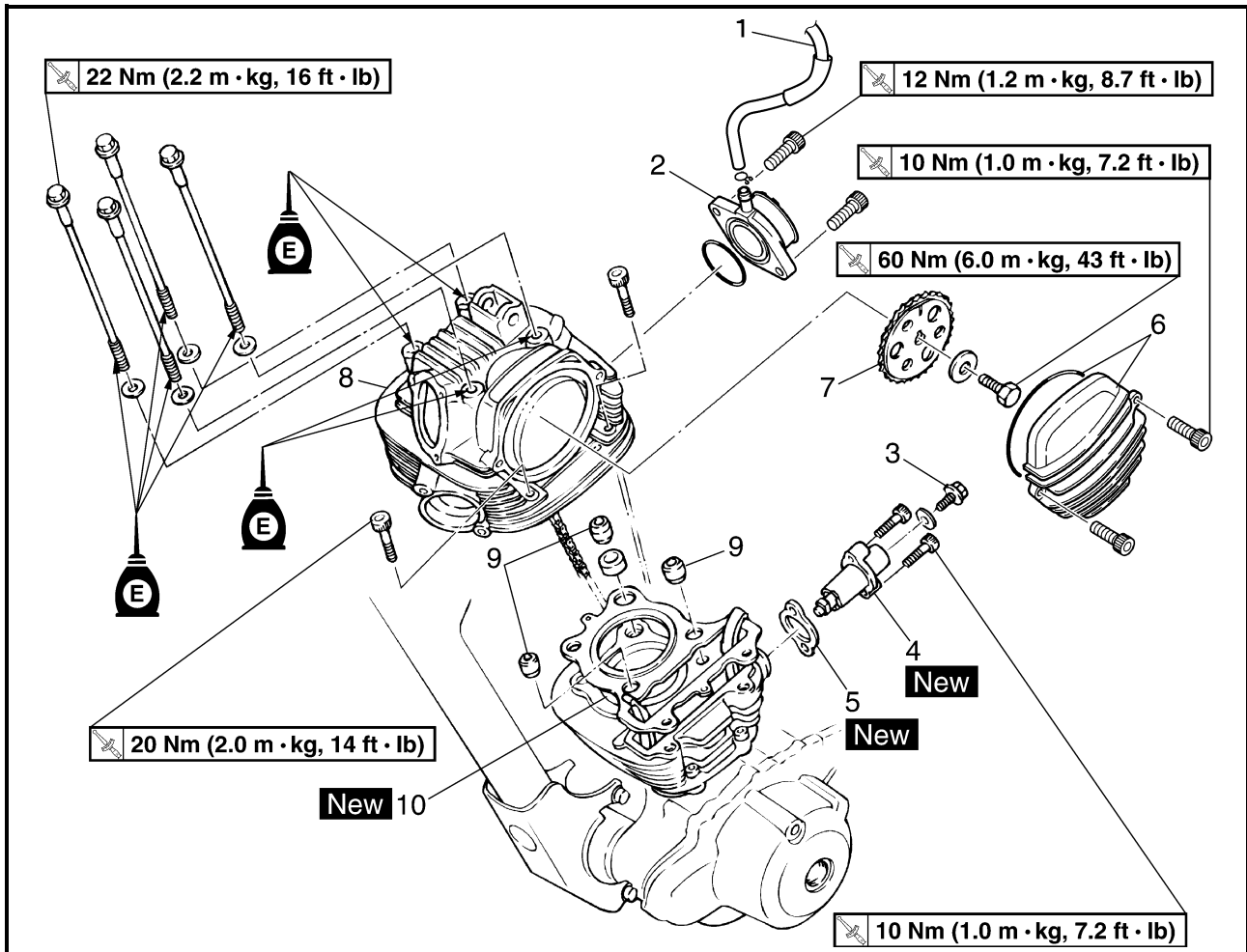

Order	Job/Part	Q'ty	Remarks
	Removing the cylinder head		Remove the parts in the order listed. Refer to "CARBURETOR".
	Carburetor		
	Fuel tank		
	Exhaust pipe		
1	Resonator hose	1	Disconnect.
2	Carburetor joint	1	
3	Timing chain tensioner cap bolt	1	Refer to "INSTALLING THE TIMING CHAIN TENSIONER".
4	Timing chain tensioner	1	
5	Gasket	1	
6	Camshaft sprocket cover/O-ring	1/1	
7	Camshaft sprocket	1	
8	Cylinder head	1	
9	Dowel pin	3	
10	Gasket	1	
			For installation, reverse the removal procedure.



AC MAGNETO

STATOR COIL ASSEMBLY AND PICKUP COIL

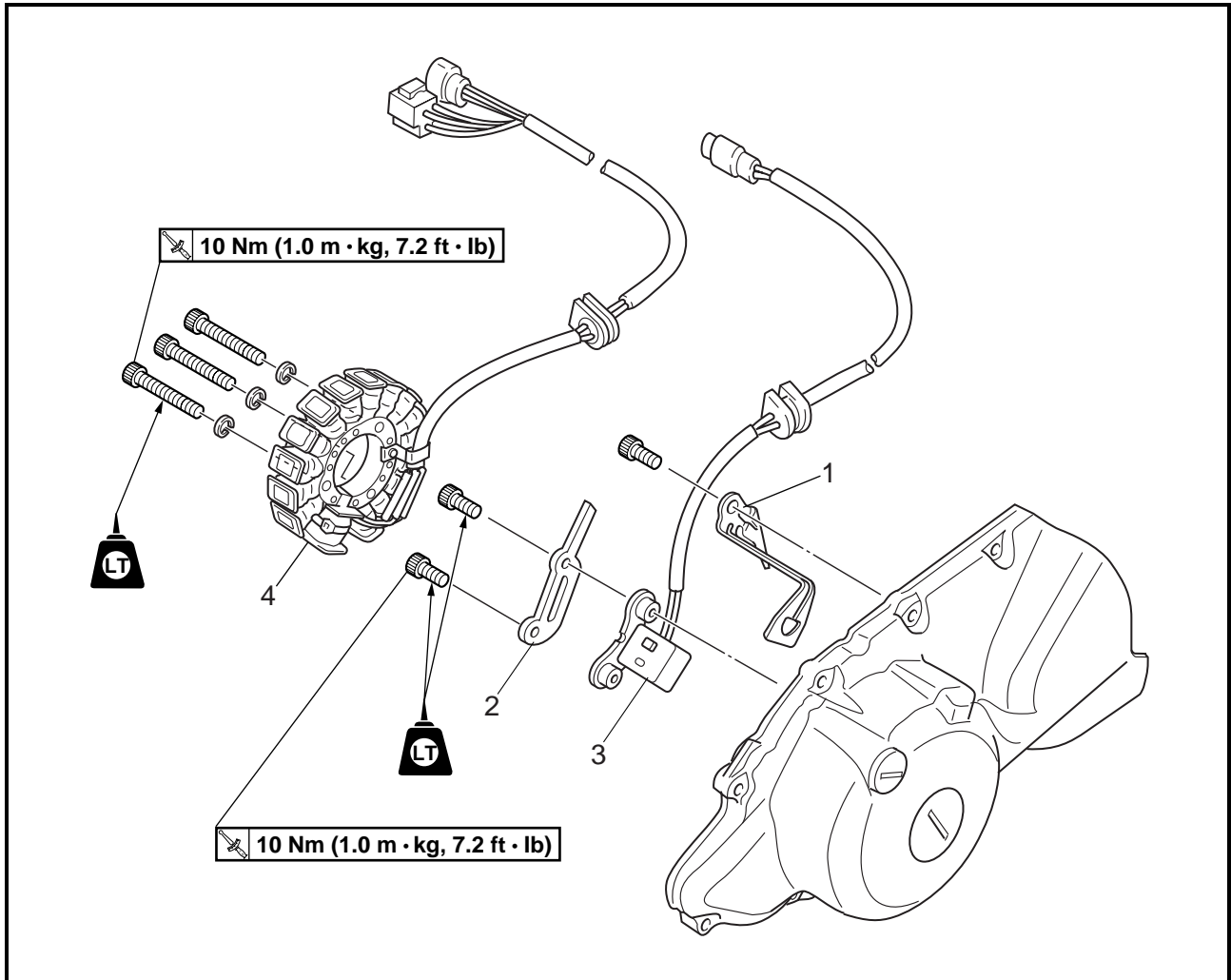

Order	Job/Part	Q'ty	Remarks
	Removing the stator coil assembly and pickup coil		Remove the parts in the order listed.
	Engine oil		Drain.
	Crankcase cover (left)		
1	Lead holder	1	
2	Pickup coil bracket	1	
3	Pickup coil	1	
4	Stator coil assembly	1	
			For installation, reverse the removal procedure.



AC MAGNETO

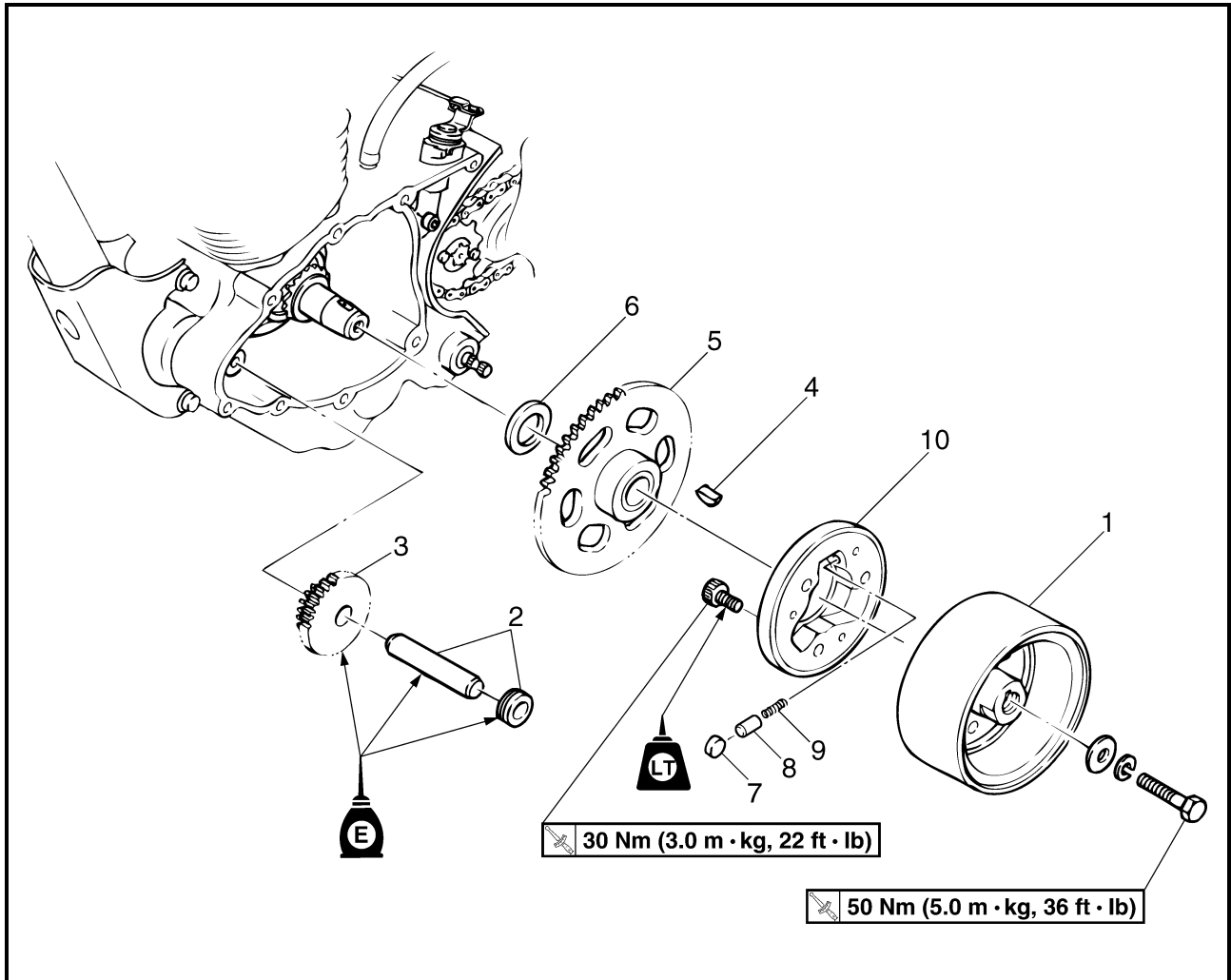

Order	Job/Part	Q'ty	Remarks
	Removing the AC magneto		Remove the parts in the order listed.
1	AC magneto	1	
2	Starter idle gear shaft/collar	1/1	
3	Starter idle gear	1	
4	Woodruff key	1	
5	Starter wheel gear	1	
6	Washer	1	
7	Roller	3	
8	Spring cap	3	
9	Spring	3	
10	Starter clutch	1	
			For installation, reverse the removal procedure.



CARBURETION

CARBURETOR

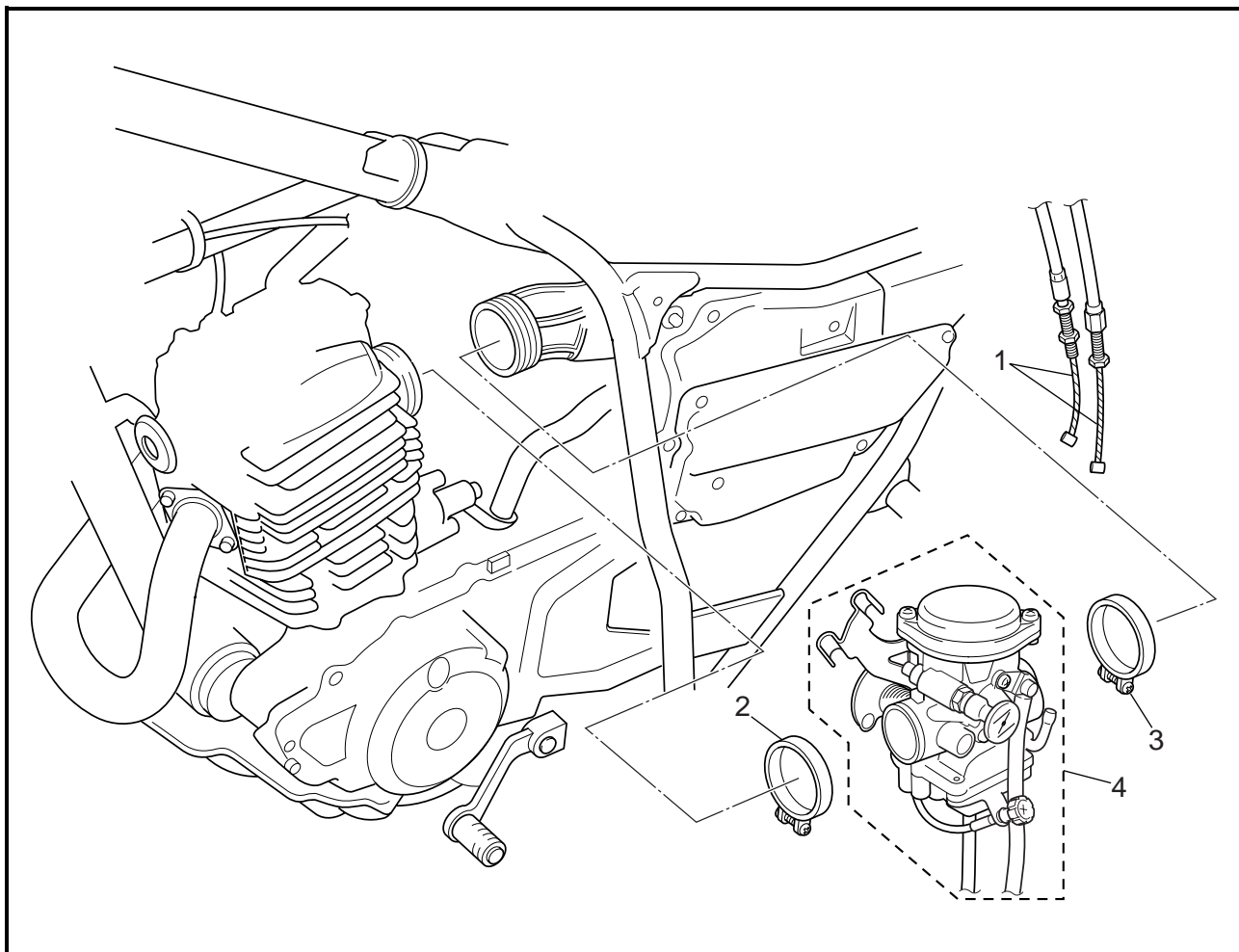

Order	Job/Part	Q'ty	Remarks
	Removing the carburetor		Remove the parts in the order listed.
	Seat		
	Side cover		
	Fuel tank		
1	Throttle cable	2	
2	Clamp (carburetor joint)	1	
3	Clamp (air filter joint)	1	
4	Carburetor assembly	1	
			For installation, reverse the removal procedure.

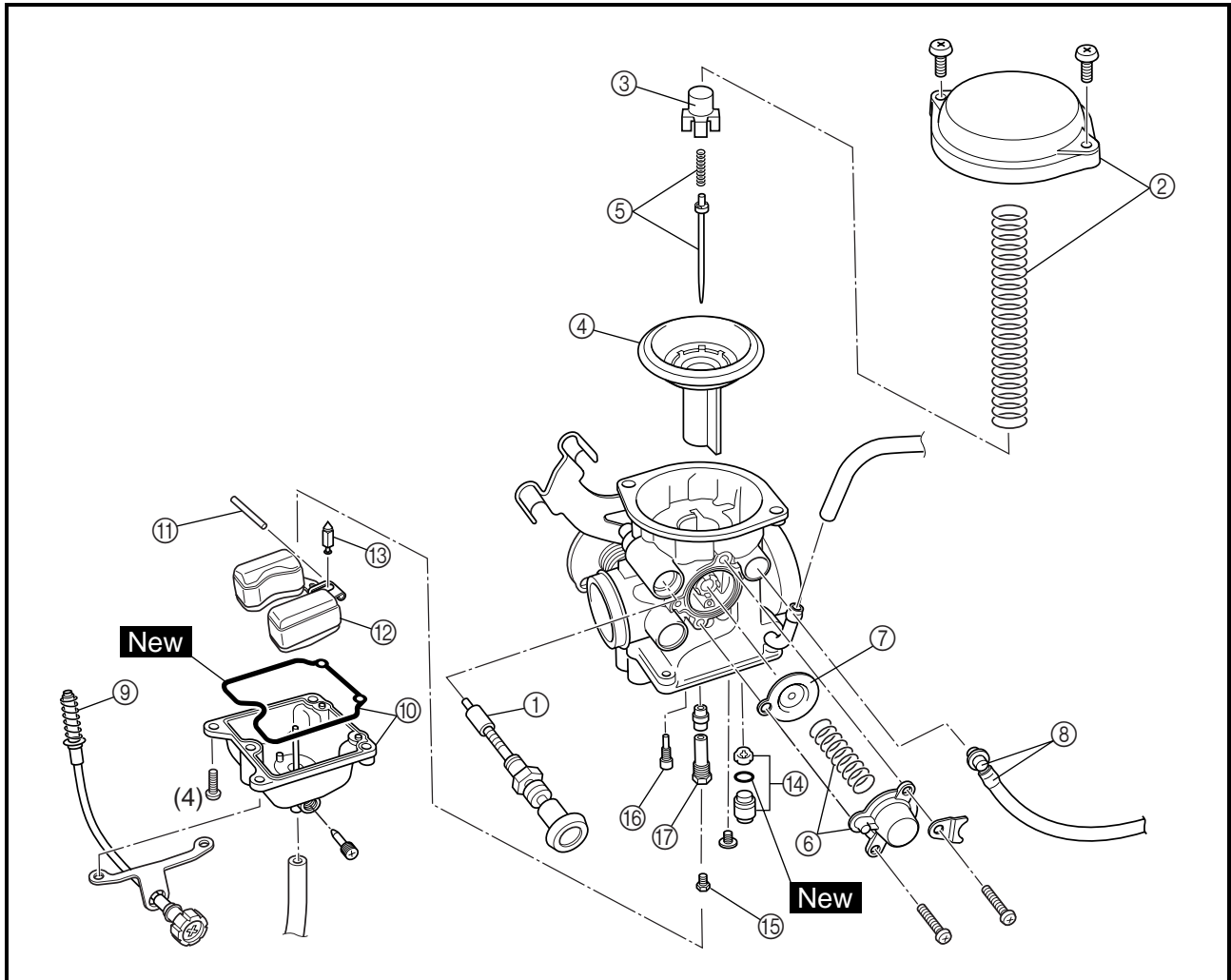

Order	Job/Part	Q'ty	Remarks
	Disassembling the carburetor		Remove the parts in the order listed.
			NOTE: _____ Before disassembling the carburetor, make sure to note the number of times the pilot screw is turned out from the seated position to its set position. _____
①	Starter plunger	1	
②	Vacuum chamber cover/spring	1/1	
③	Jet needle holder	1	
④	Piston valve	1	
⑤	Jet needle kit	1	
⑥	Coasting enricher cover/spring	1/1	
⑦	Coasting enricher	1	
⑧	Air vent hose/joint	1/1	
⑨	Throttle stop screw assembly	1	

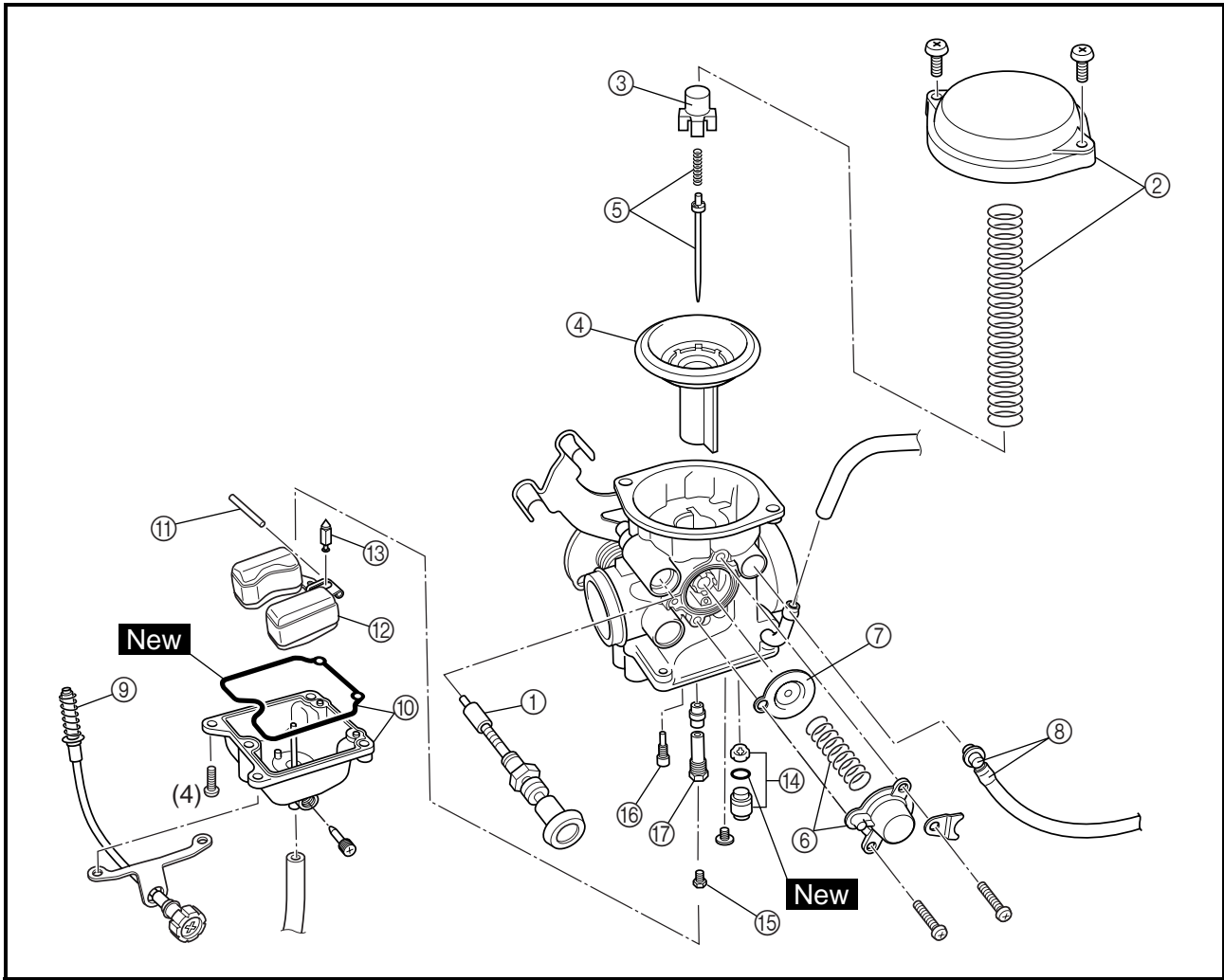

Order	Job/Part	Q'ty	Remarks
⑩	Float chamber/gasket	1/1	Refer to "ASSEMBLING THE CARBU-RETOR".
⑪	Float pin	1	
⑫	Float	1	
⑬	Needle valve	1	
⑭	Valve seat set	1	
⑮	Main jet	1	
⑯	Pilot jet	1	
⑰	Main jet nozzle	1	
			For assembly, reverse the disassembly procedure.

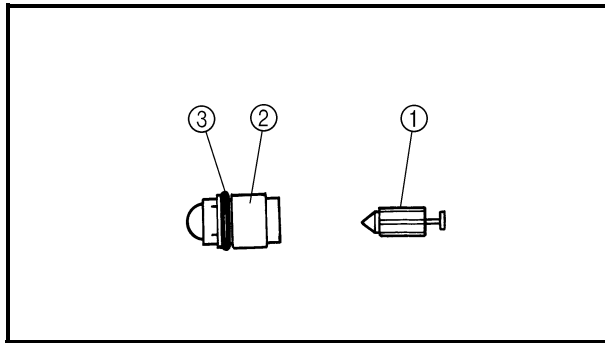

6. Check:

- needle valve ①
- needle valve seat ②

Damage/obstruction/wear → Replace the needle valve, needle valve seat and O-ring as a set.

7. Check:

- O-ring ③

Damage/wear → Replace the needle valve, needle valve seat and O-ring as a set.

8. Check:

- piston valve ①
 - piston valve diaphragm ②
- Damage/scratches/wear → Replace.
- Cracks/tears → Replace.

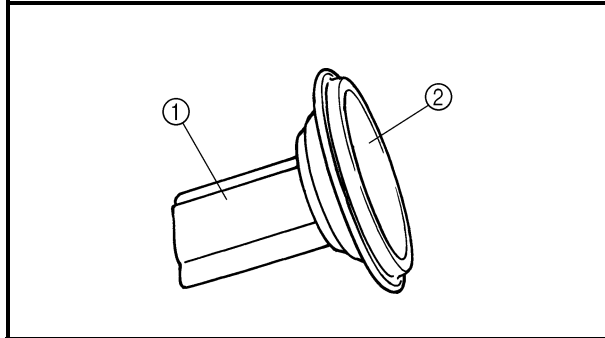

9. Check:

- vacuum chamber cover ①
 - piston valve spring ②
 - jet needle holder ③
 - jet needle spring ④
- Cracks/damage → Replace.

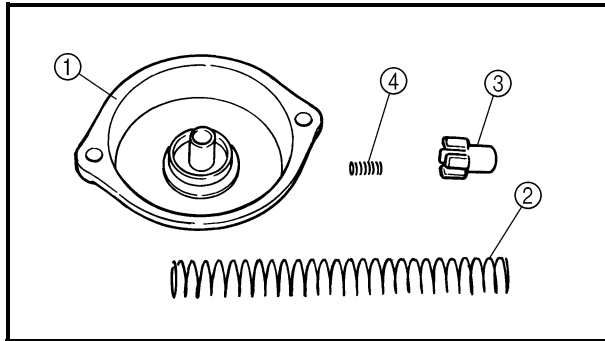

10. Check:

- jet needle kit ①
- main jet ②
- main jet holder ③
- pilot jet ④
- starter plunger ⑤

Bends/damage/wear → Replace.

Obstruction → Clean.

Blow out the jets with compressed air.

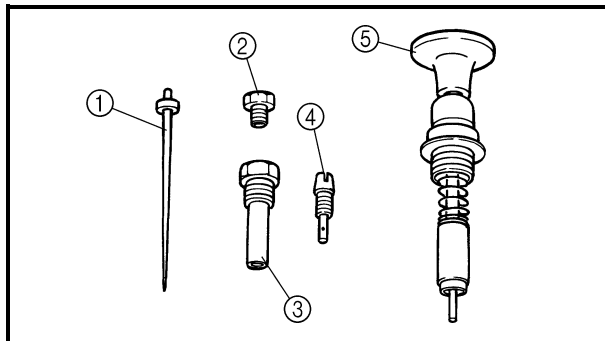

11. Check:

- piston valve movement
- Insert the piston valve into the carburetor body and move it up and down.
- Tightness → Replace the piston valve.

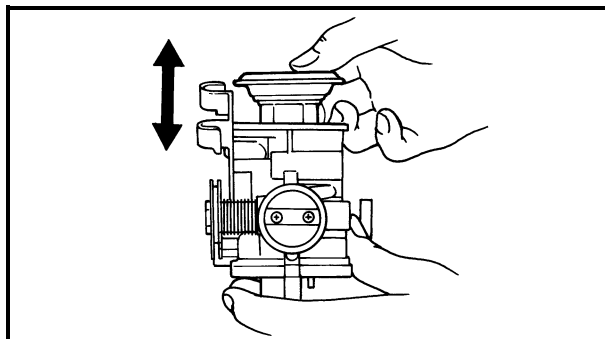

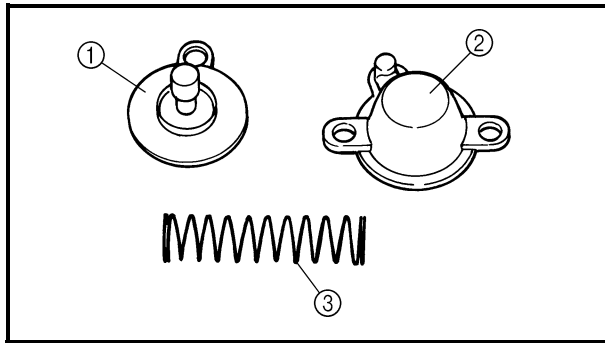

12. Check:

- casting enricher ①
Cracks/tears → Replace.
- casting enricher cover ②
- casting enricher spring ③
Cracks/damage → Replace.

13. Check:

- fuel hoses
Cracks/damage/wear → Replace.
Obstruction → Clean.
Blow out the hoses with compressed air.

14. Check:

- hose joint
Cracks/damage/wear → Replace.
Obstruction → clean.
Blow out to the joint with compressed air.

ASSEMBLING THE CARBURETOR

CAUTION: _____

- Before assembling the carburetors, wash all of the parts in a petroleum based solvent.
- Always use a new gasket.

NOTE: _____

Before assembling the carburetor, make sure to turn out the pilot screw the same number of times, as noted before disassembly, from the seated position to the set position.

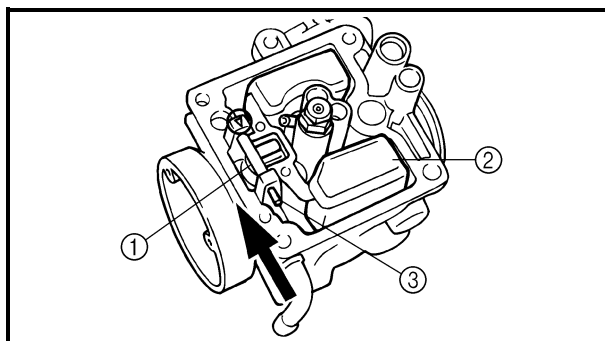

1. Install:

- needle valve ①
- float ②
- float pin ③

NOTE: _____

Install the float pin from the side opposite the arrow.

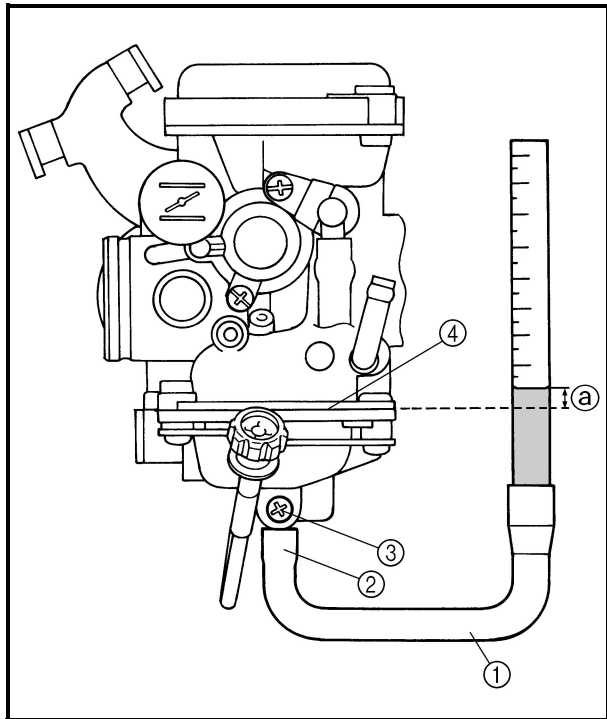

MEASURING AND ADJUSTING THE FUEL LEVEL

1. Measure:

- fuel level (a)

Out of specification → Adjust.



Fuel level (above the line on the float chamber mating surface)
0.5 ~ 1.5 mm (0.02 ~ 0.06 in)



- Stand the motorcycle on a level surface.
- Place the motorcycle on a suitable stand to ensure that the motorcycle is standing straight up.
- Install the fuel level gauge (1) onto the fuel drain pipe (2).



Fuel level gauge
YM-01312-A

- Loosen the fuel drain screw (3).
- Hold the fuel level gauge vertically next to the line (4) on the float chamber.
- Measure the fuel level (a).

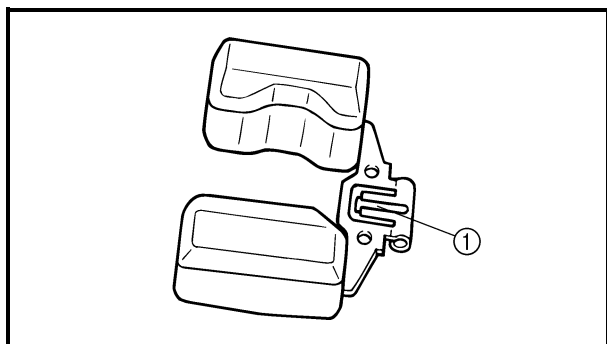

2. Adjust:

- fuel level



- Remove the carburetor assembly.
- Check the needle valve seat and needle valve.
- If either is worn, replace them as a set.
- If both are fine, adjust the float level by slightly bending the float tang (1).
- Install the carburetor assembly.
- Measure the fuel level again.
- Repeat steps (a) to (f) until the fuel level is within specification.



CHASSIS

FRONT WHEEL AND BRAKE DISC

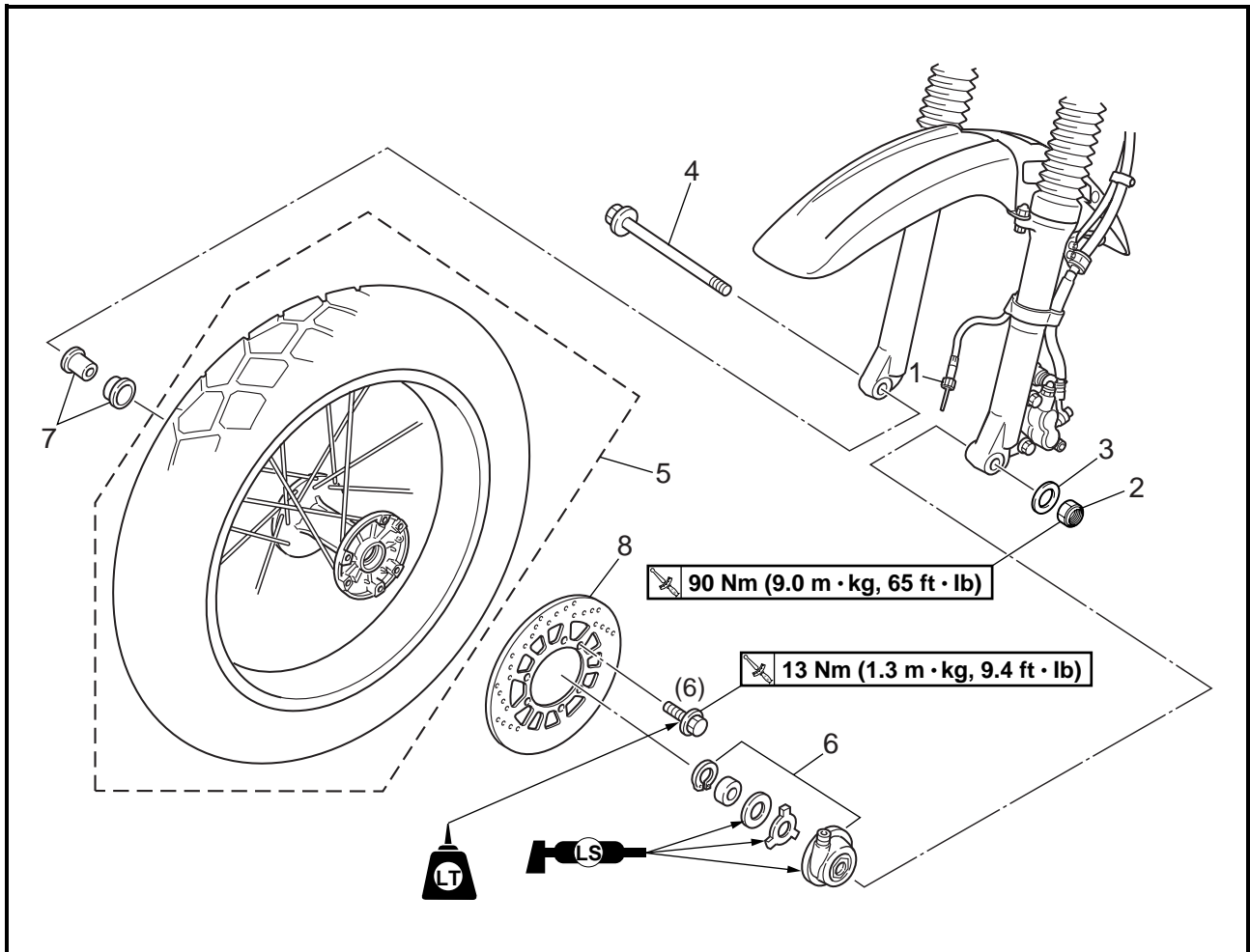

Order	Job/Part	Q'ty	Remarks
	Removing the front wheel and brake disc		Remove the parts in the order listed.
			NOTE: _____ Place the motorcycle on a suitable stand so that the front wheel is elevated.
1	Speedometer cable	1	Refer to "REMOVING AND INSTALLING THE FRONT WHEEL".
2	Axle nut	1	
3	Washer	1	
4	Front wheel axle	1	
5	Front wheel	1	
6	Speedometer gear unit	1	
7	Collar/dust seal	1/1	
8	Brake disc	1	
			Refer to "INSTALLING THE FRONT WHEEL". For installation, reverse the removal procedure.

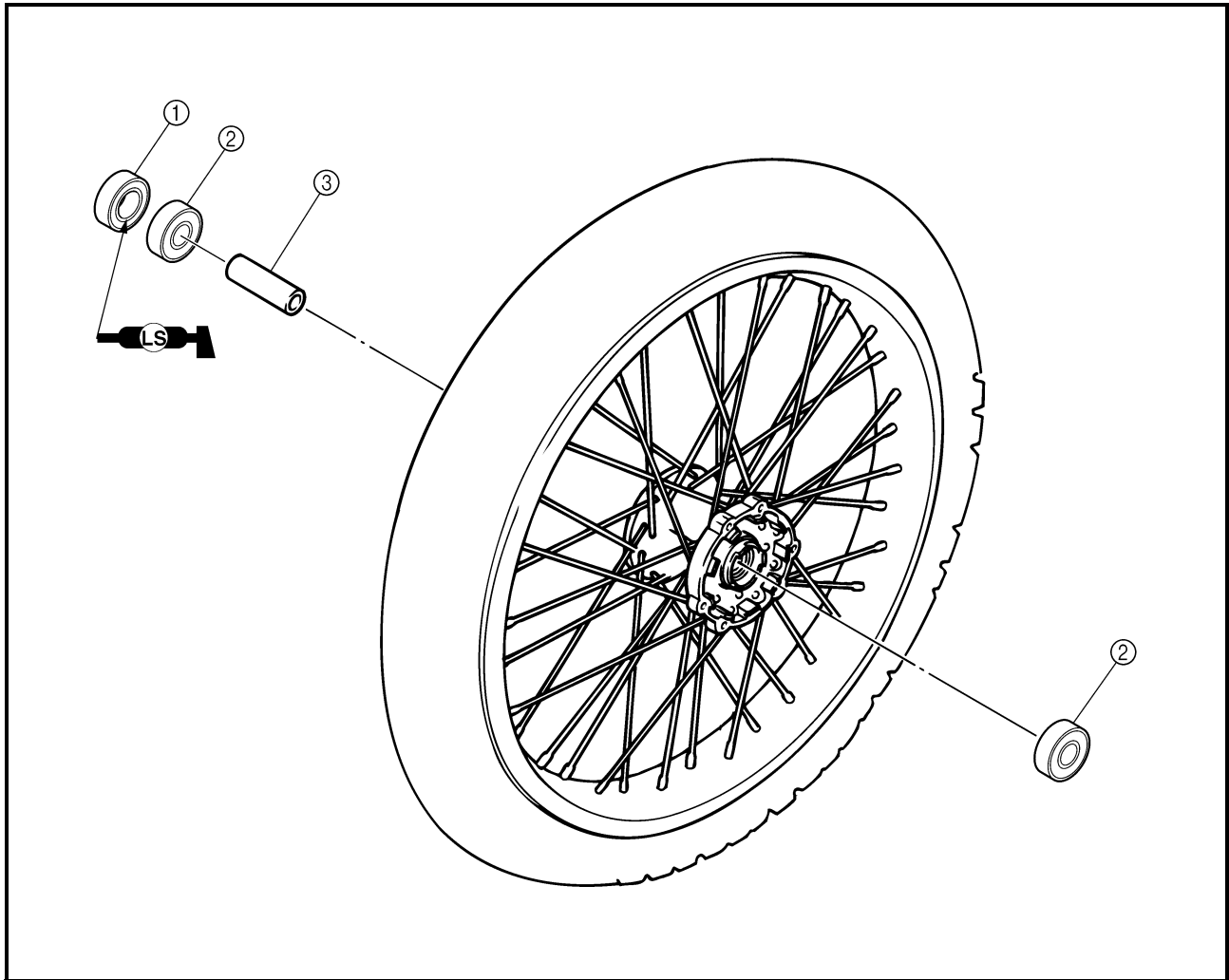

Order	Job/Part	Q'ty	Remarks
	Disassembling the front wheel		Remove the parts in the order listed.
①	Oil seal	1	
②	Wheel bearing (left and right)	2	
③	Spacer	1	
			For assembly, reverse the disassembly procedure.



REMOVING THE FRONT WHEEL

1. Stand the motorcycle on a level surface.

⚠ WARNING

Securely support the motorcycle so that there is no danger of it falling over.

NOTE:

Place the motorcycle on a suitable stand so that the front wheel is elevated.

2. Loosen:
 - axle nut:
3. Elevate:
 - front wheel

NOTE:

Place the motorcycle on a suitable stand so that the front wheel is elevated.

4. Remove:
 - axle nut
 - washer
 - front wheel axle
 - front wheel

NOTE:

Do not squeeze the brake lever when removing the front wheel.

CHECKING THE BRAKE DISC

1. Check:
 - brake disc
Damage/galling → Replace.



- d. Measure the brake disc deflection.
- e. If out of specification, repeat the adjustment steps until the brake disc deflection is within specification.
- f. If the brake disc deflection cannot be brought within specification, replace the brake disc.



INSTALLING THE FRONT WHEEL

1. Lubricate:
 - wheel axle
 - oil seal lips



Recommended lubricant
Lithium soap base grease

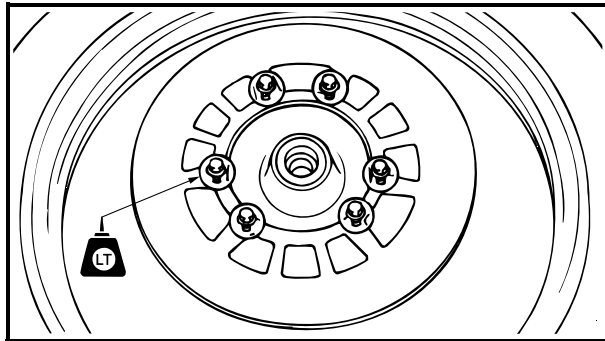

2. Install:

- brake discs **13 Nm (1.3 m · kg, 9.4 ft · lb)**

NOTE: _____

- Apply locking agent (LOCTITE®) to the threads of the brake disc bolts.
 - Tighten the brake disc bolts in stages and in a crisscross pattern.
- _____

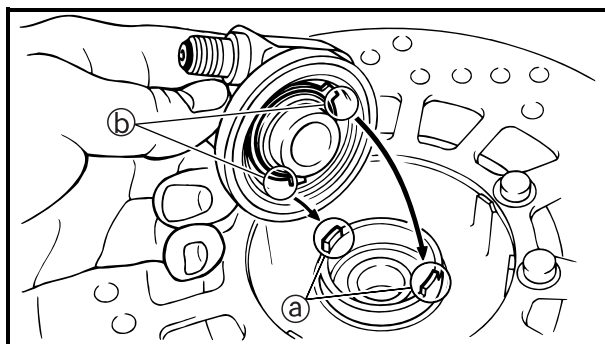

3. Install:

- speedometer gear unit

NOTE: _____

Make sure the projections (a) in the wheel hub are meshed with the slots (b) in the speedometer gear unit.

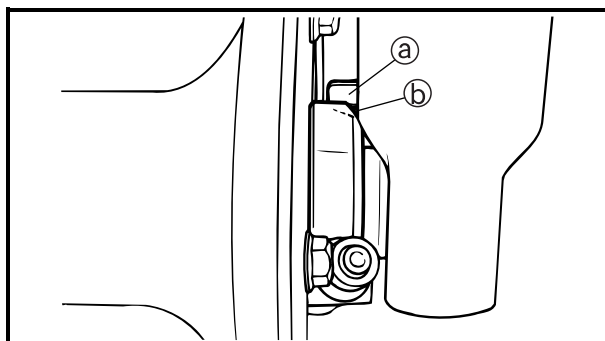

4. Install:

- front wheel

NOTE: _____

Make sure the projection (a) (torque stopper) in the front fork is placed (b) in the speedometer gear unit as shown.

FRONT WHEEL AND BRAKE DISC

CHAS

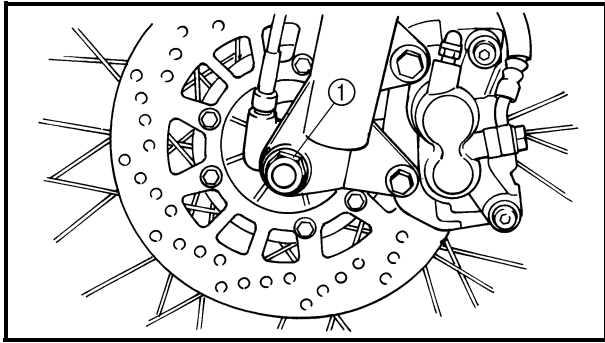

5. Tighten:

- wheel axle nut ①

 90 Nm (9.0 m · kg, 65 ft · lb)

CAUTION:

Before tightening the wheel axle nut, push down hard on the handlebars several times and check if the front fork rebounds smoothly.

FRONT BRAKE
FRONT BRAKE PADS

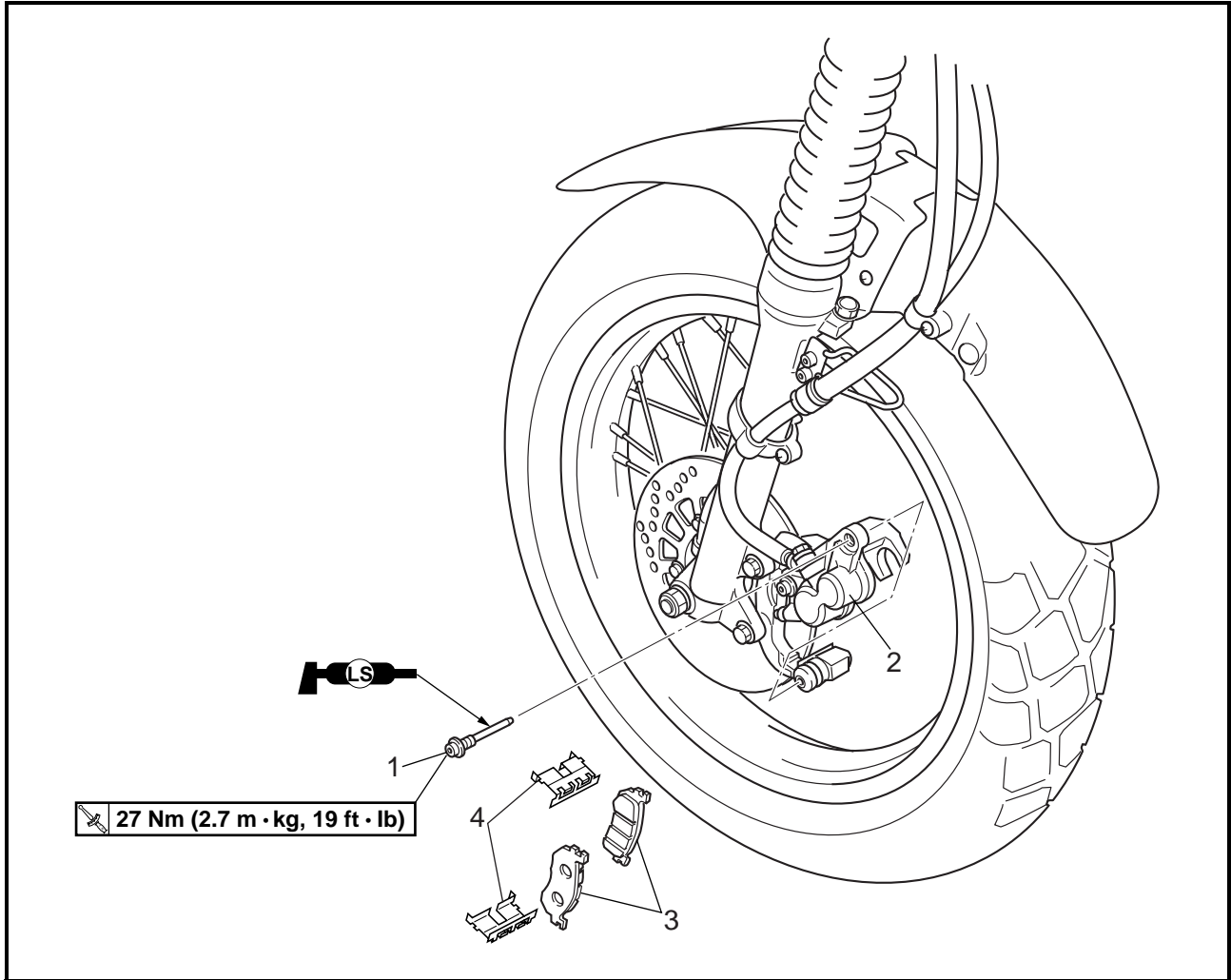

Order	Job/Part	Q'ty	Remarks
	Removing the front brake pads		Remove the parts in the order listed.
1	Retaining bolt (lower)	1	
2	Brake caliper	1	
3	Brake pad	2	
4	Brake pad spring	2	
			For installation, reverse the removal procedure.

**CAUTION:**

Disc brake components rarely require disassembly.

Therefore, always follow these preventive measures:

- Never disassemble brake components unless absolutely necessary.
- If any connection on the hydraulic brake system is disconnected, the entire brake system must be disassembled, drained, cleaned, properly filled, and bled after reassembly.
- Never use solvents on internal brake components.
- Use only clean or new brake fluid for cleaning brake components.
- Brake fluid may damage painted surfaces and plastic parts. Therefore, always clean up any spilt brake fluid immediately.
- Avoid brake fluid coming into contact with the eyes as it can cause serious injury.

First aid for brake fluid entering the eyes:

- Flush with water for 15 minutes and get immediate medical attention.

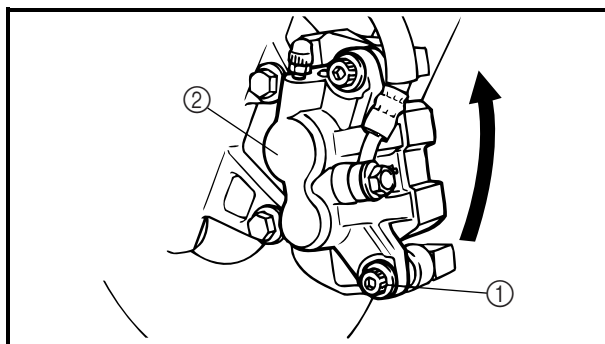
**REPLACING THE FRONT BRAKE PADS****NOTE:**

When replacing the brake pads, it is not necessary to disconnect the brake hose or disassemble the brake caliper.

1. Remove:
 - retaining bolt (lower) ①

NOTE:

Move the brake caliper ② upward.



5. Install:
 - retaining bolt (lower)

 27 Nm (2.7 m · kg, 19 ft · lb)

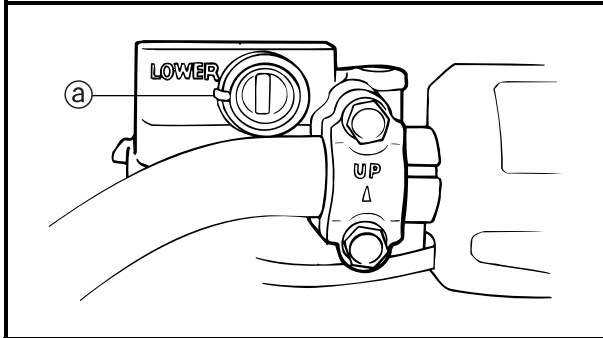

6. Check:
 - brake fluid level
Below the minimum level mark (a) → Add the recommended brake fluid to the proper level.
Refer to “CHECKING THE BRAKE FLUID LEVEL”.

7. Check:
 - brake lever operation
Soft or spongy feeling → Bleed the brake system.
Refer to “BLEEDING THE HYDRAULIC BRAKE SYSTEM”.

FRONT BRAKE MASTER CYLINDER

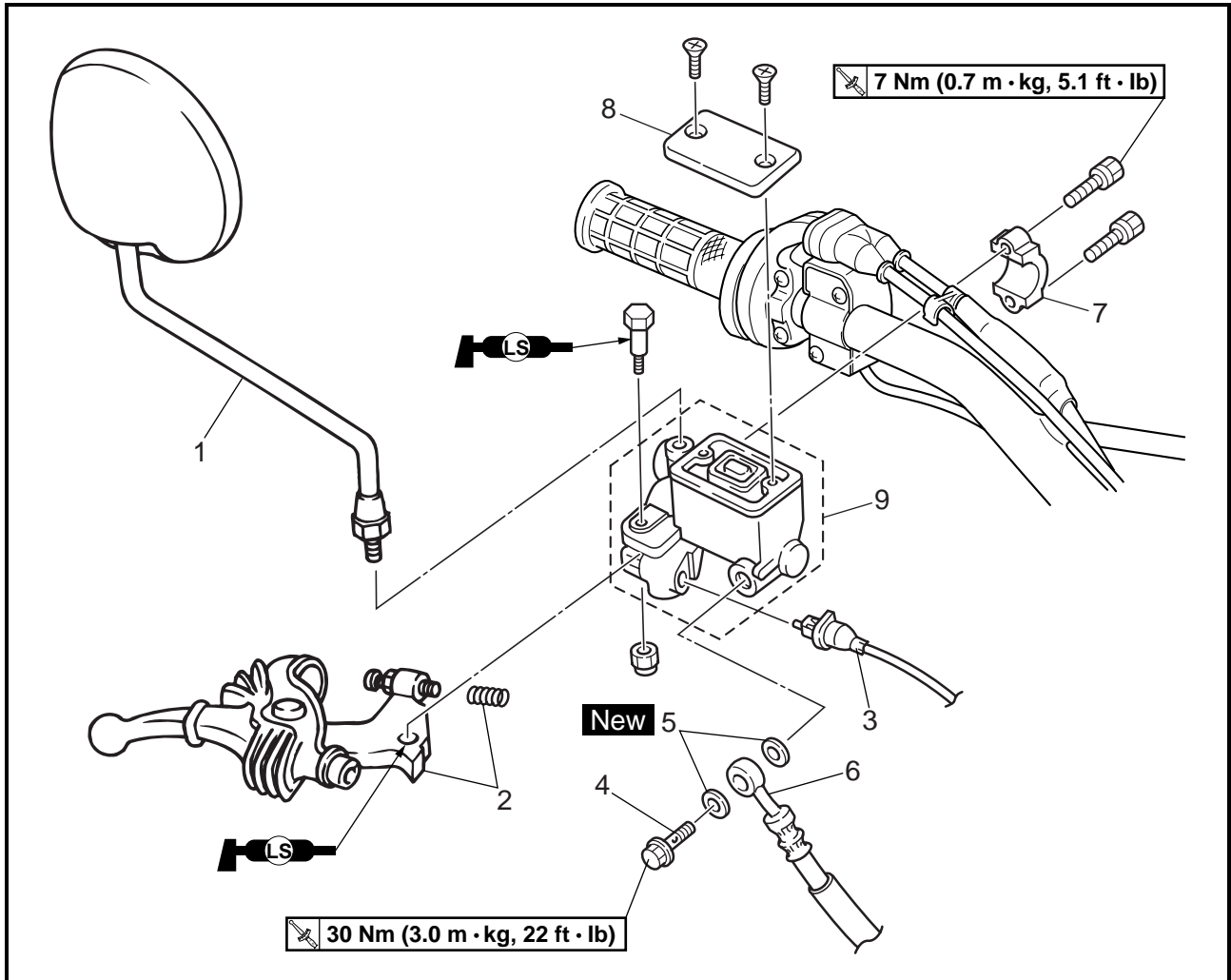

Order	Job/Part	Q'ty	Remarks
	Removing the front brake master cylinder		Remove the parts in the order listed.
	Brake fluid		Drain.
1	Rear view mirror (right)	1	
2	Brake lever/spring	1/1	
3	Front brake light switch	1	
4	Union bolt	1	
5	Copper washer	2	
6	Brake hose	1	
7	Brake master cylinder holder	1	
8	Brake master cylinder reservoir cap	1	
9	Brake master cylinder assembly	1	
			For installation, reverse the removal procedure.

DISASSEMBLING THE FRONT BRAKE MASTER CYLINDER

NOTE: _____

Before disassembling the front brake master cylinder, drain the brake fluid from the entire brake system.

1. Disconnect
 - front brake light switch
2. Remove:
 - union bolt ①
 - copper washers ②
 - brake hose ③

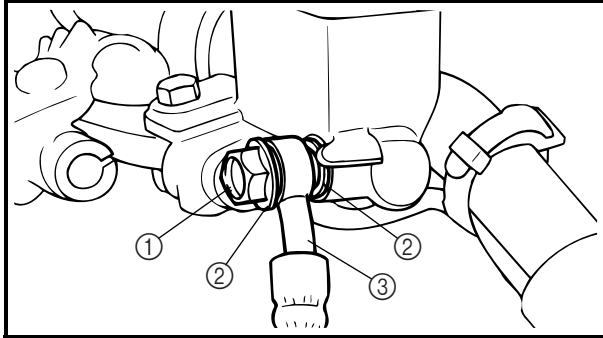

NOTE: _____

To collect any remaining brake fluid, place a container under the master cylinder and the end of the brake hose.

CHECKING THE FRONT BRAKE MASTER CYLINDER

1. Check:
 - brake master cylinder ①
Damage/scratches/wear → Replace.
 - brake fluid delivery passages (brake master cylinder body)
Obstruction → Blow out with compressed air.
2. Check:
 - brake master cylinder kit
Damage/scratches/wear → Replace.
3. Check:
 - brake master cylinder reservoir ①
Cracks/damage → Replace.
 - brake master cylinder reservoir diaphragm ②
Damage/were → Replace.

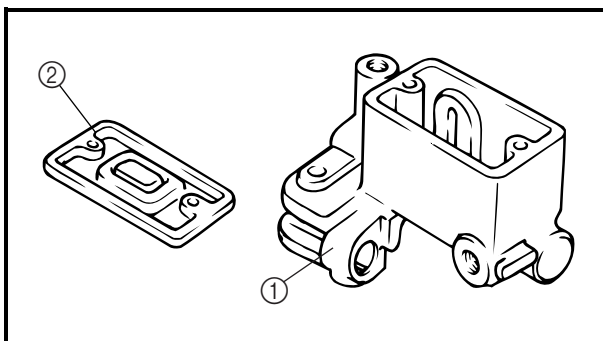
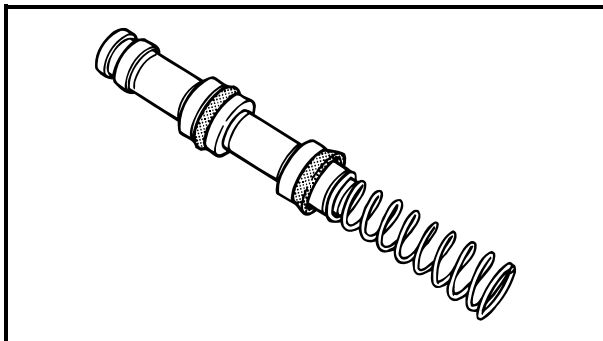
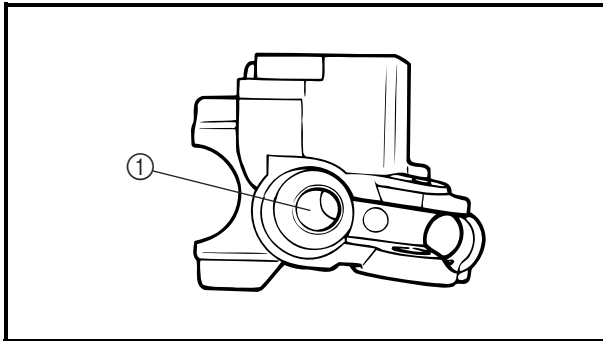



ASSEMBLING AND INSTALLING THE FRONT BRAKE MASTER CYLINDER

⚠ WARNING

- Before installation, all internal brake components should be cleaned and lubricated with clean or new brake fluid.
- Never use solvents on internal brake components.

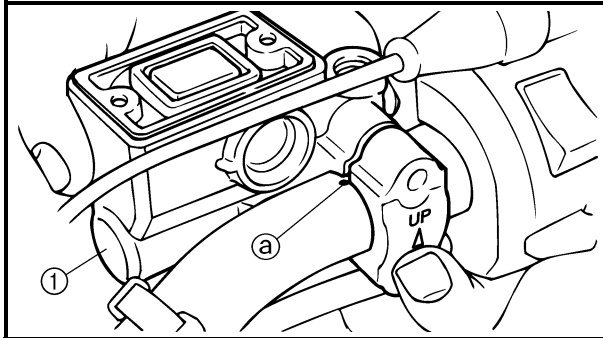

Recommended brake fluid
DOT 4

1. Install:
 - brake master cylinder ①

7 Nm (0.4 m · kg, 5.1 ft · lb)

NOTE:

- Install the brake master cylinder holder with the “UP” mark facing up.
- Align the end of the brake master cylinder holder with the punch mark ② in the right handlebar.
- First, tighten the upper bolt, then the lower bolt.

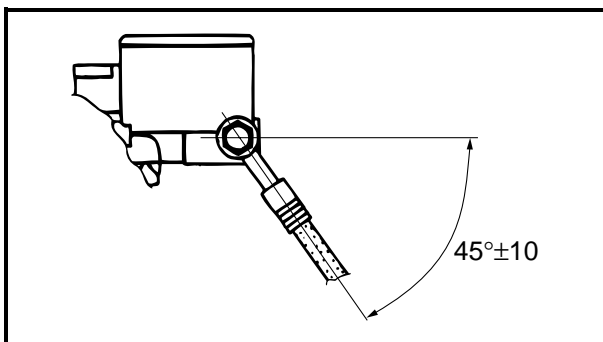

2. Install:

- copper washers **New**
- brake hose
- union bolt 30 Nm (3.0 m · kg, 22 ft · lb)

⚠ WARNING

Proper brake hose routing is essential to insure safe motorcycle operation. Refer to “CABLE ROUTING”.

NOTE:

- While holding the brake hose, tighten the union bolt as shown.
- Turn the handlebars to the left and to the right to make sure that the brake hose does not touch other parts (e.g., wire harness, cables, leads). Correct if necessary.



3. Fill:
 - brake fluid reservoir
(with the specified amount of the recommended brake fluid)



**Recommended brake fluid
DOT 4**

⚠ WARNING

- Use only the designated brake fluid. Other brake fluids may cause the rubber seals to deteriorate, causing leakage and poor brake performance.
- Refill with the same type of brake fluid that is already in the system. Mixing brake fluids may result in a harmful chemical reaction, leading to poor brake performance.
- When refilling, be careful that water does not enter the brake fluid reservoir. Water will significantly lower the boiling point of the brake fluid and could cause vapor lock.

CAUTION:

Brake fluid may damage painted surfaces and plastic parts. Therefore, always clean up any spilt brake fluid immediately.

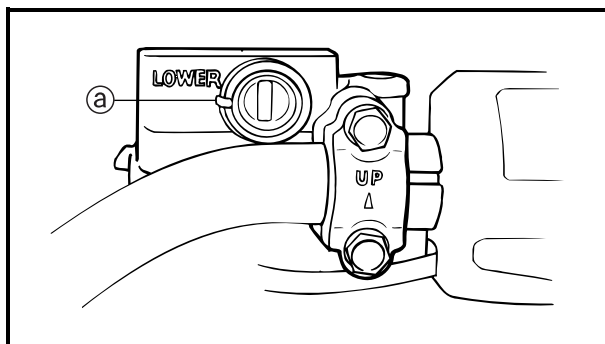

4. Bleed:
 - brake system
Refer to “BLEEDING THE HYDRAULIC BRAKE SYSTEM”.
5. Check:
 - brake fluid level
Below the minimum level mark (a) → Add the recommended brake fluid to the proper level.
Refer to “CHECKING THE BRAKE FLUID LEVEL”.
6. Check:
 - brake lever operation
Soft or spongy feeling → Bleed the brake system.
Refer to “BLEEDING THE HYDRAULIC BRAKE SYSTEM”.

FRONT BRAKE CALIPER

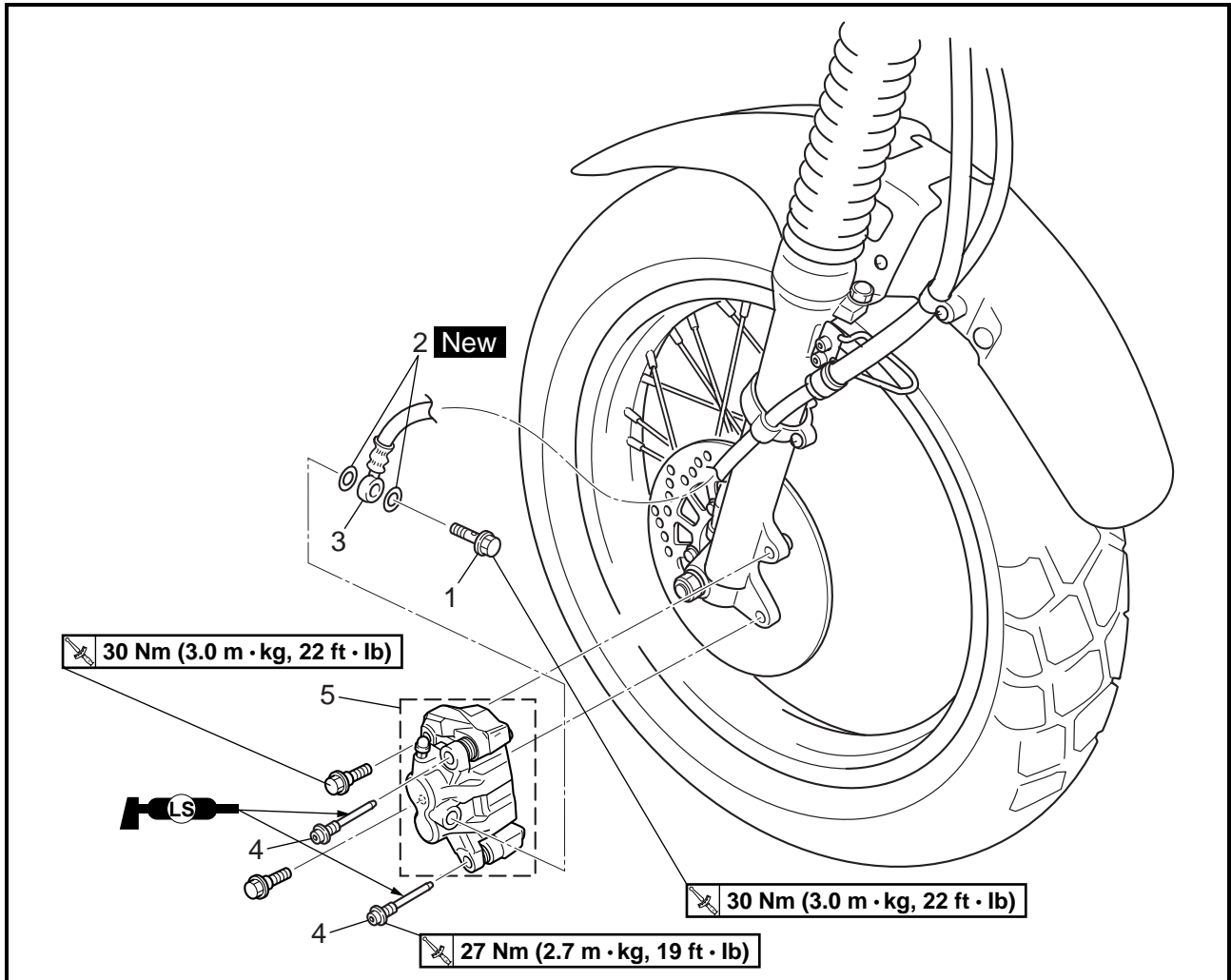

Order	Job/Part	Q'ty	Remarks
	Removing the front brake calipers		Remove the parts in the order listed.
	Brake fluid		Drain.
1	Union bolt	1	
2	Copper washer	2	
3	Brake hose	1	
4	Retaining bolt	2	Loosen.
5	Brake caliper	1	
			For installation, reverse the removal procedure.

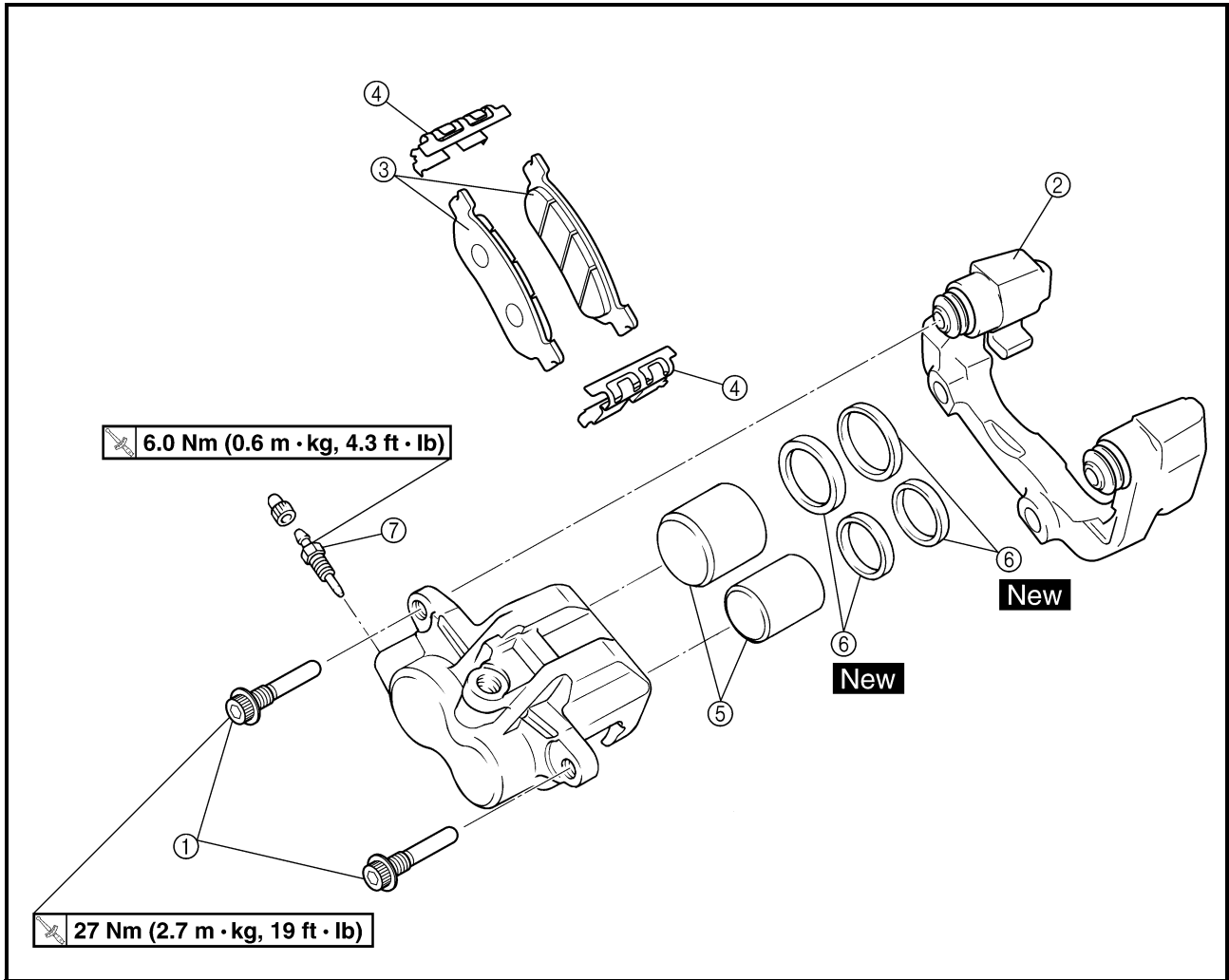

Order	Job/Part	Q'ty	Remarks
	Disassembling the front brake calipers		Remove the parts in the order listed.
①	Retaining bolt	2	
②	Brake caliper bracket	1	
③	Brake pad	2	
④	Brake pad spring	2	
⑤	Brake caliper piston	2	
⑥	Brake caliper piston seal	4	
⑦	Bleed screw	1	
			For assembly, reverse the disassembly procedure.



CHECKING THE FRONT AND REAR BRAKE CALIPERS

Recommended brake component replacement schedule	
Brake pads	If necessary
Piston seals	Every two years
Brake hoses	Every four years
Brake fluid	Every two years and whenever the brake is disassembled

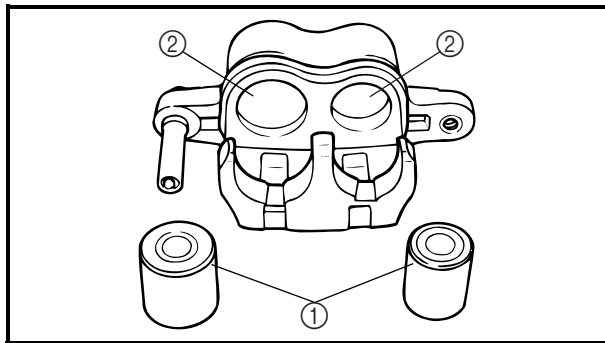

1. Check:

- brake caliper pistons ①
Rust/scratches/wear → Replace the brake caliper.
- brake caliper cylinders ②
Scratches/wear → Replace the brake caliper.
- brake calipers
Cracks/damage → Replace.
- brake fluid delivery passages (brake caliper body)
Obstruction → Blow out with compressed air.

⚠ WARNING

Whenever a brake caliper is disassembled, replace the brake caliper piston seals.

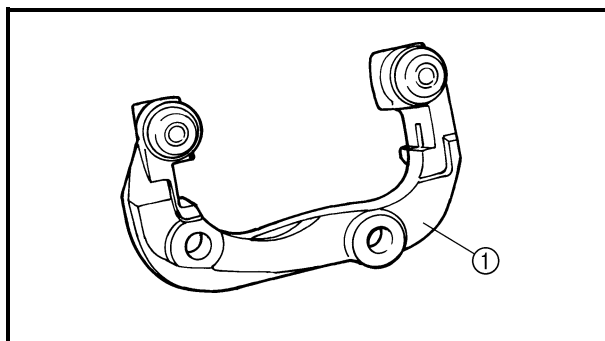

2. Check:

- brake caliper bracket ①
Cracks/damage → Replace.



ASSEMBLING AND INSTALLING THE FRONT BRAKE CALIPERS

⚠ WARNING

- Before installation, all internal brake components should be cleaned and lubricated with clean or new brake fluid.
- Never use solvents on internal brake components as they will cause the piston seals to swell and distort.
- Whenever a brake caliper is disassembled, replace the brake caliper piston seals.



Recommended brake fluid
DOT 4

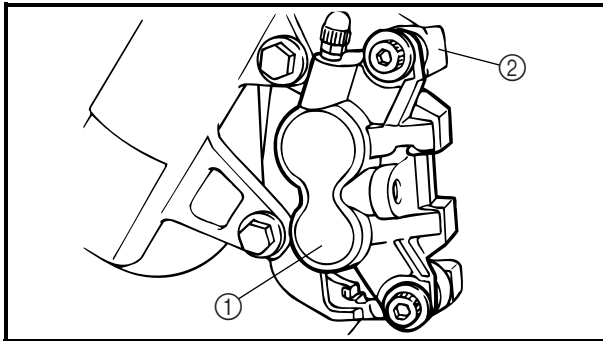

1. Install:

- brake caliper bracket ①

30 Nm (3.0 m · kg, 22 ft · lb)

- brake caliper ②

NOTE:

Temporarily tighten the retaining bolts.

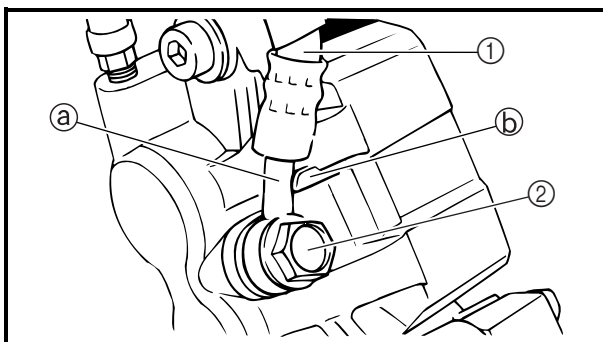

2. Install:

- copper washers **New**

- brake hose ①

- union bolt ②

30 Nm (3.0 m · kg, 22 ft · lb)

⚠ WARNING

Proper brake hose routing is essential to insure safe motorcycle operation. Refer to “CABLE ROUTING”.

CAUTION:

When installing the brake hose onto the brake caliper, make sure that the brake pipe ① touches the projection ② on the brake caliper.



3. Remove:
 - retaining bolt (lower)
4. Install:
 - brake pad springs
 - brake pads
 - brake caliper  27 Nm (2.7 m · kg, 19 ft · lb)

5. Fill:
 - Brake fluid reservoir
(with the specified amount of the recommended brake fluid)



**Recommended brake fluid
DOT4**

⚠ WARNING

- Use only the designated brake fluid. Other brake fluids may cause the rubber seals to deteriorate, causing leakage and poor brake performance.
- Refill with the same type of brake fluid that is already in the system. Mixing brake fluids may result in a harmful chemical reaction, leading to poor brake performance.
- When refilling, be careful that water does not enter the brake fluid reservoir. Water will significantly lower the boiling point of the brake fluid and could cause vapor lock.

CAUTION:

Brake fluid may damage painted surfaces and plastic parts. Therefore, always clean up any spilt brake fluid immediately.

6. Bleed:
 - brake system
Refer to “BLEEDING THE HYDRAULIC BRAKE SYSTEM”.

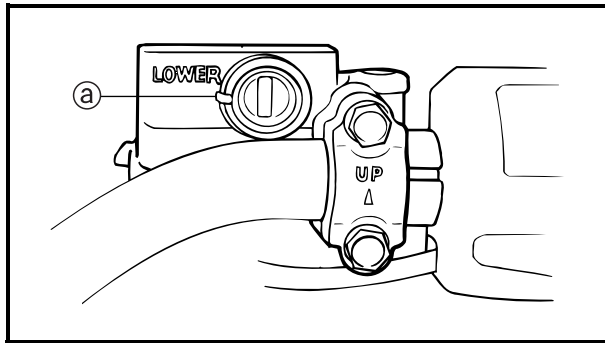

7. Check:

- brake fluid level
Below the minimum level mark @ → Add the recommended brake fluid to the proper level.
Refer to “CHECKING THE BRAKE FLUID LEVEL”.

8. Check:

- brake lever operation
Soft or spongy feeling → Bleed the brake system.
Refer to “BLEEDING THE HYDRAULIC BRAKE SYSTEM”.

FRONT FORK

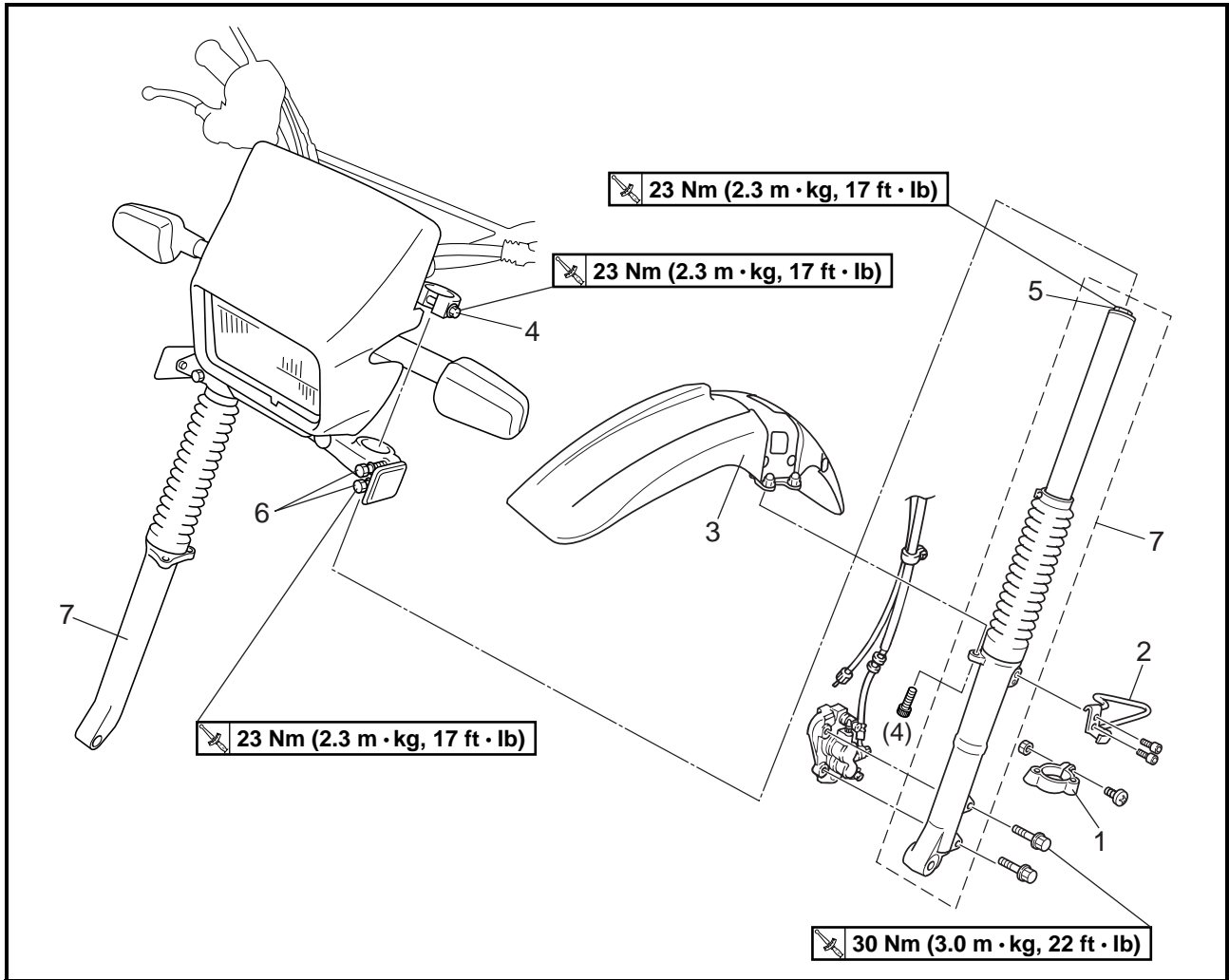

Order	Job/Part	Q'ty	Remarks
	Removing the front fork legs		Remove the parts in the order listed. The following procedure applies to both of the front fork legs. Refer to "FRONT WHEEL AND BRAKE DISCS".
	Front wheel		
1	Brake hose holder	1	
2	Cable guide	1	
3	Front fender	1	
4	Upper bracket pinch bolt	1	Loosen.
5	Cap bolt	1	Loosen.
6	Lower bracket pinch bolt	2	Loosen.
7	Front fork leg	1	
			For installation reverse the removal procedure.



STEERING HEAD

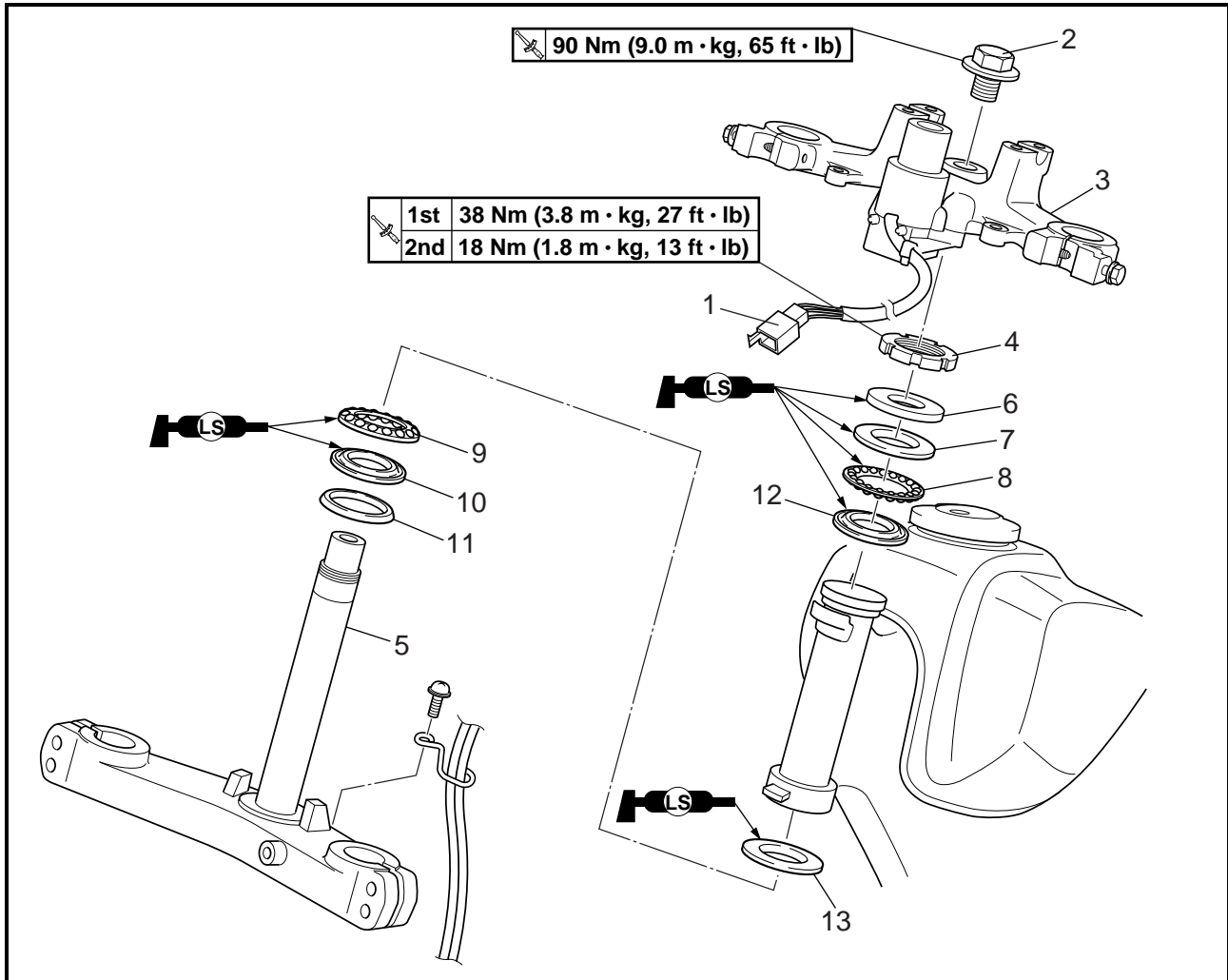

Order	Job/Part	Q'ty	Remarks
	Removing the lower bracket		Remove the parts in the order listed.
	Front fork legs		
	Headlight stay assembly/meter assembly		
1	Main switch coupler	1	Disconnect.
2	Steering stem bolt	1	
3	Upper bracket	1	
4	Ring nut	1	
5	Lower bracket	1	
6	Bearing cover	1	
7	Bearing inner race	1	
8	Upper bearing	1	
9	Lower bearing	1	
10	Bearing inner race	1	
11	Rubber washer	1	

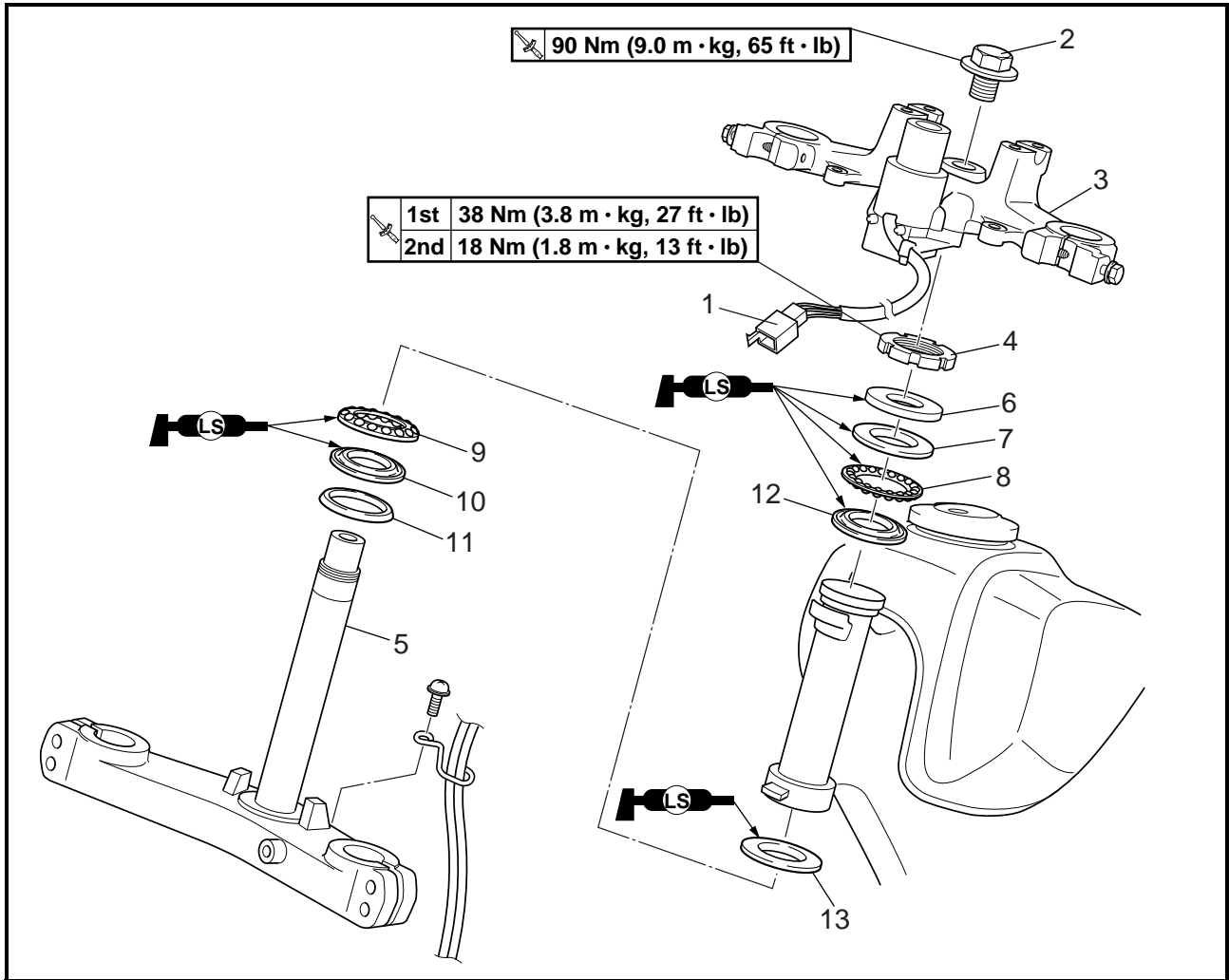

Order	Job/Part	Q'ty	Remarks
12	Bearing outer race	1	For installation reverse the removal procedure.
13	Bearing outer race	1	

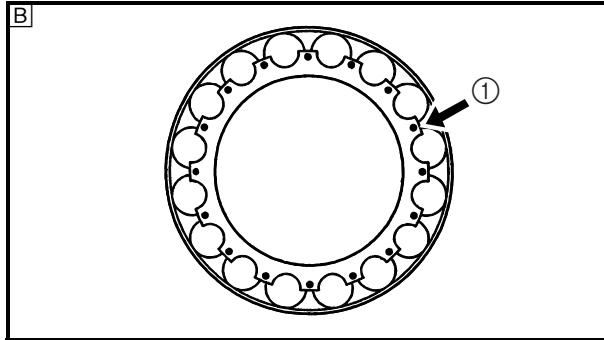
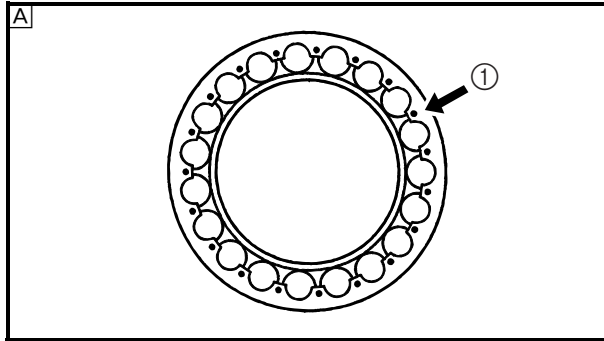

INSTALLING THE BEARING (RETAINER TYPE)

1. Install:
 - Bearing (retainer type)

NOTE: _____

- When install the bearing (retainer type) make sure that the projections ① on the surface of the bearing face upward.
- Since there are differences in both the upper and lower bearings, the bearings can be identified by the projection on the surface of the retainer.

Ⓐ Upper

Ⓑ Lower

ELECTRICAL

ELECTRICAL COMPONENTS

- | | |
|----------------------------|---------------------------|
| ① Wire harness | ⑪ Rectifier/regulator |
| ② Main switch | ⑫ Turn signal relay |
| ③ Front brake light switch | ⑬ Sidestand switch |
| ④ Main fuse | ⑭ Neutral switch |
| ⑤ Starter relay | ⑮ Pickup coil |
| ⑥ Neutral relay | ⑯ Stator coil assembly |
| ⑦ Diode | ⑰ Rear brake light switch |
| ⑧ CDI unit | ⑱ Horn |
| ⑨ Clutch switch | |
| ⑩ Battery | |

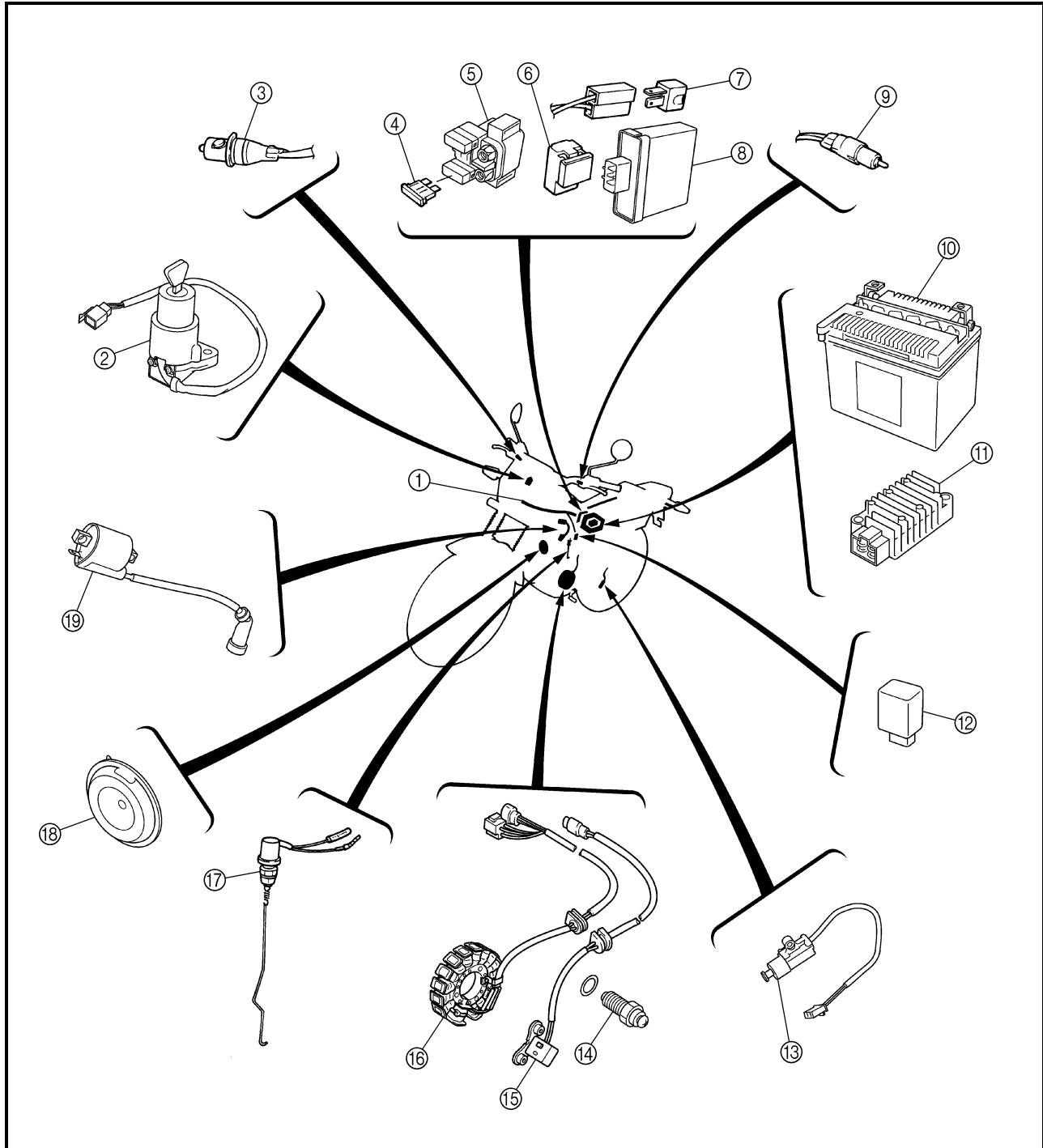

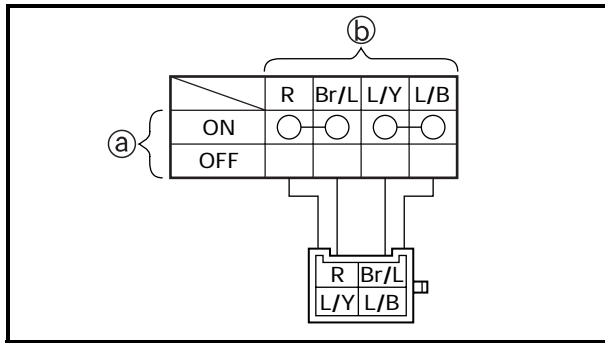
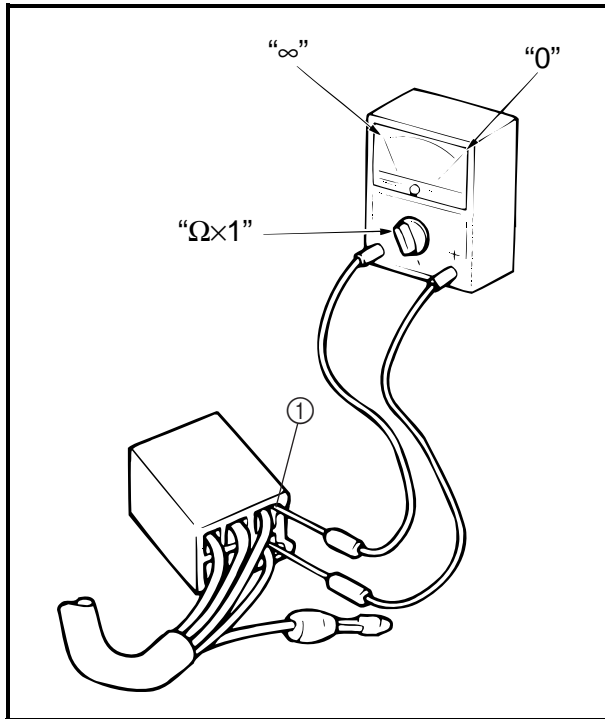
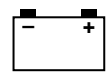

SWITCHES

CHECKING SWITCH CONTINUITY

Check each switch for continuity with the pocket tester. If the continuity reading is incorrect, check the wiring connections and if necessary, replace the switch.

CAUTION:

Never insert the tester probes into the coupler terminal slots ①. Always insert the probes from the opposite end of the coupler, taking care not to loosen or damage the leads.



**Pocket tester
YU-03112**

NOTE:

- Before checking for continuity, set the pocket tester to “0” and to the “Ω × 1” range.
- When checking for continuity, switch back and forth between the switch positions a few times.

The terminal connections for switches (e.g., main switch, engine stop switch) are shown in an illustration similar to the one on the left.

The switch positions ① are shown in the far left column and the switch lead colors ② are shown in the top row in the switch illustration.

NOTE:

“○—○” indicates a continuity of electricity between switch terminals (i.e., a closed circuit at the respective switch position).

The example illustration on the left shows that:

There is continuity between red and brown/blue, and between blue/yellow and blue/black when the switch is set to “ON”.

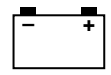

CHECKING THE SWITCHES

Check each switch for damage or wear, proper connections, and also for continuity between the terminals. Refer to “CHECKING SWITCH CONTINUITY”.

Damage/wear → Repair or replace the switch.

Improperly connected → Properly connect.

Incorrect continuity reading → Replace the switch.

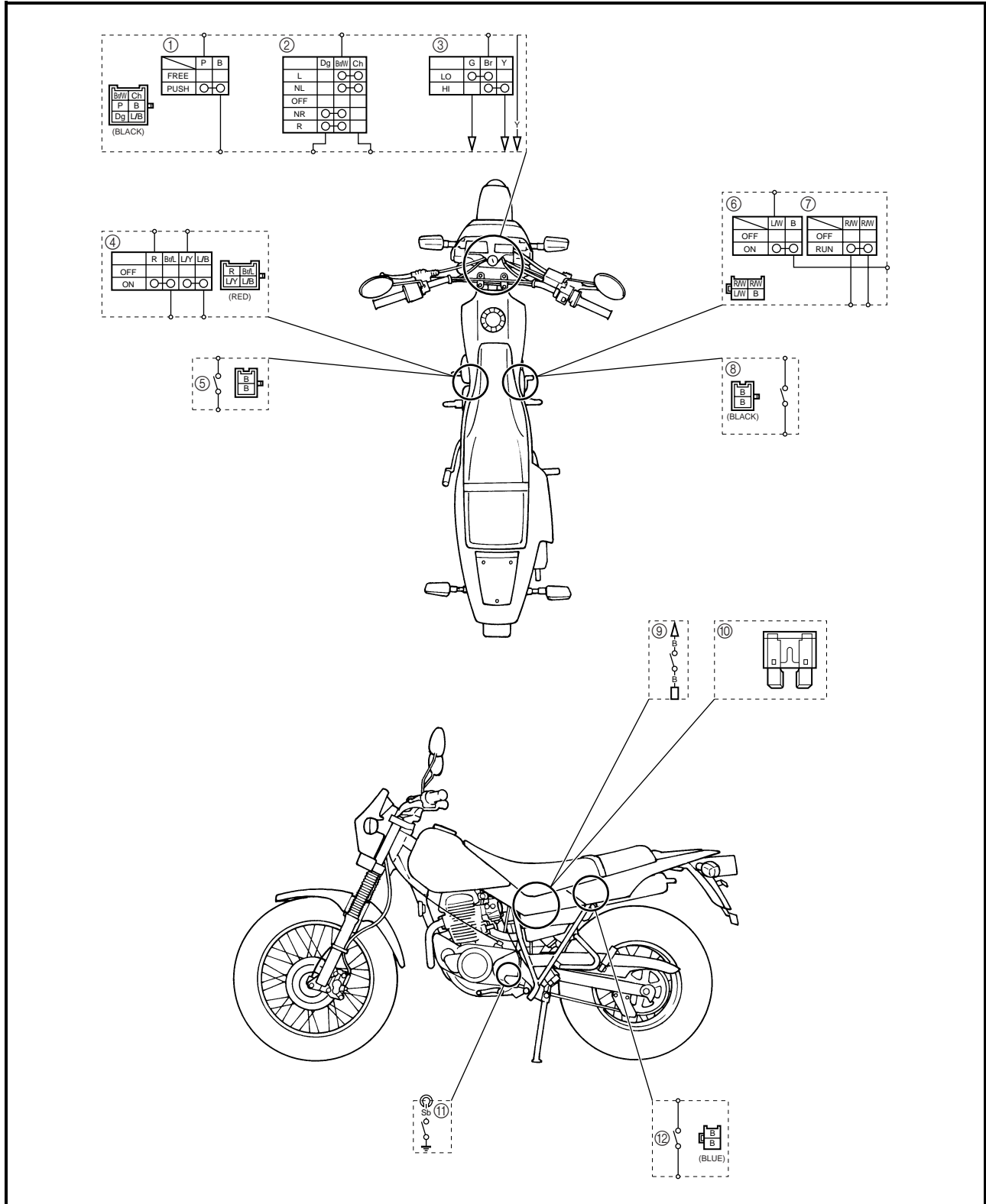

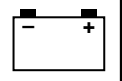

- ① Horn switch
- ② Turn signal switch
- ③ Dimmer switch
- ④ Main switch
- ⑤ Clutch switch
- ⑥ Start switch
- ⑦ Engine stop switch
- ⑧ Front brake light switch
- ⑨ Rear brake light switch
- ⑩ Fuse
- ⑪ Neutral switch
- ⑫ Sidestand switch

**IGNITION SYSTEM
CIRCUIT DIAGRAM**

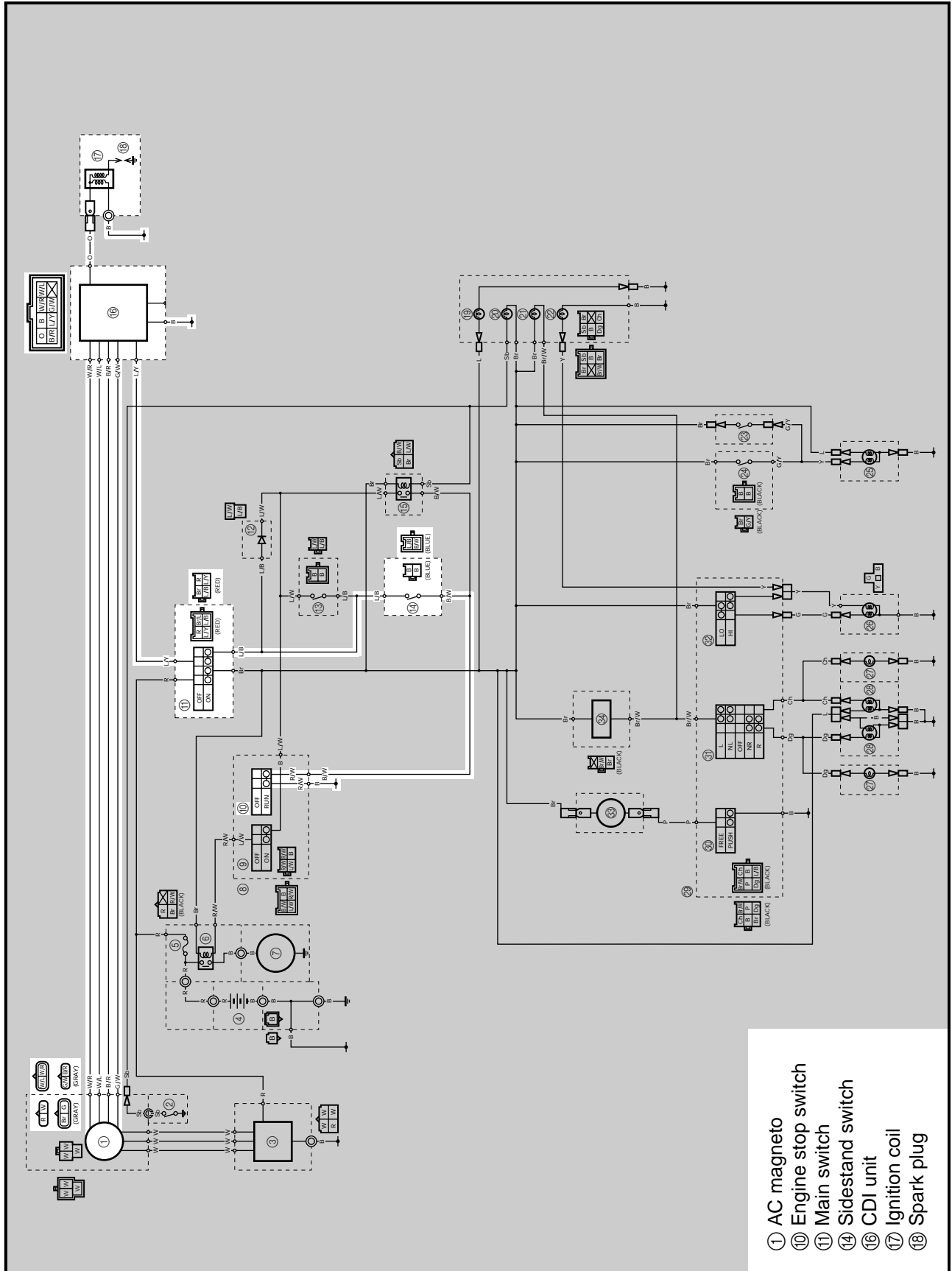

- ① AC magneto
- ⑩ Engine stop switch
- ⑪ Main switch
- ⑭ Side stand switch
- ⑮ CDI unit
- ⑰ Ignition coil
- ⑱ Spark plug

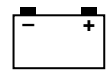

TROUBLESHOOTING

The ignition system fails to operate (no spark or intermittent spark).

Check:

1. spark plug
2. ignition spark gap
3. spark plug cap resistance
4. ignition coil resistance
5. pickup coil resistance
6. source coil resistance
7. main switch
8. engine stop switch
9. sidestand switch
10. wiring (of the entire ignition system)

NOTE:

- Before troubleshooting, remove the following part (-s):
 - 1) rider seat
 - 2) fuel tank
 - 3) side cover (left and right)
- Troubleshoot with the following special tool (-s).



**Dynamic spark tester
YM-34487
Pocket tester
YU-03112**

1. Spark plug

The following procedure applies to all of the spark plug.

- Check the condition of the spark plug.
- Check the spark plug type.
- Measure the spark plug gap.



**Standard spark plug
DR8EA (NGK)
X24ESR-U (DENSO)
Spark plug gap
0.6 ~ 0.7 mm (0.024 ~ 0.028 in)**

- Is the spark plug in good condition, is it of the correct type, and its gap within specification?



YES



NO

Re-gap or replace the spark plug.

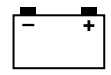

2. Ignition spark gap

The following procedure applies to all of the spark plug.

- Disconnect the spark plug cap from the spark plug.
- Connect the dynamic spark tester ① as shown.
- ② Spark plug cap
- Set the main switch to "ON".
- Measure the ignition spark gap ③.
- Crank the engine by pushing the start switch and gradually increase the spark gap until a misfire occurs.

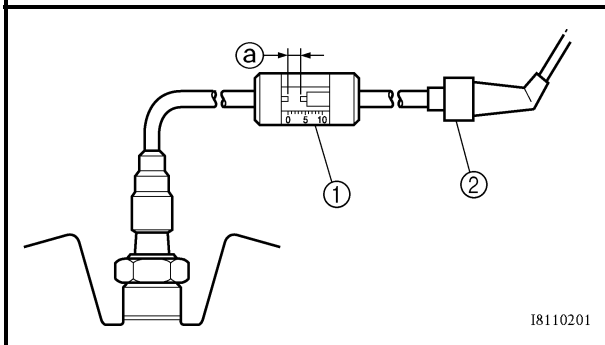

 **Min.ignition spark gap
6 mm (0.24 in)**

- Is there a spark and is the spark gap within specification?

NO

YES

The ignition system is OK.

3. Spark plug cap resistance

The following procedure applies to all of the spark plug cap.

- Disconnect the spark plug cap from the spark plug.
- Connect the pocket tester ($\Omega \times 1k$) to the spark plug cap as shown.
- Measure the spark plug cap resistance.

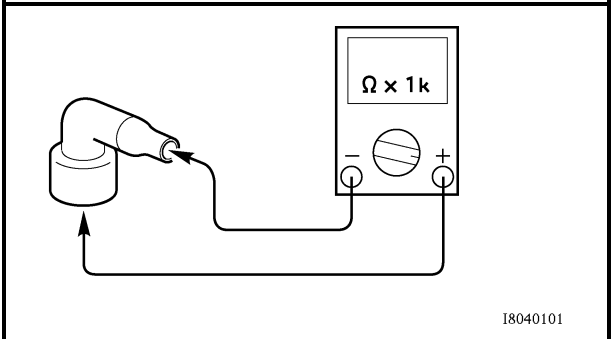

 **Spark plug cap resistance
10 k Ω at 20 °C (68 °F)**

- Is the spark plug cap OK?

YES

NO

Replace the spark plug cap.

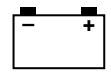

4. Ignition coil resistance

- Disconnect the ignition coil connector from the ignition coil terminal.
- Connect the pocket tester ($\Omega \times 1$) to the ignition coil as shown.

Tester Positive → orange

Tester negative → ignition coil base

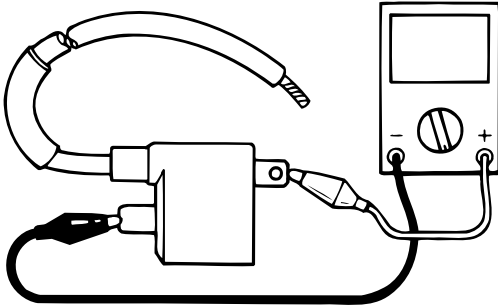

- Measure the primary coil resistance.



Primary coil resistance
0.18 ~ 0.28 Ω at 20 °C (68 °F)

- Connect the pocket tester ($\Omega \times 1k$) to the ignition coil as shown.
- Measure the secondary coil resistance.

Tester positive probe → orange

Tester positive probe → spark plug lead

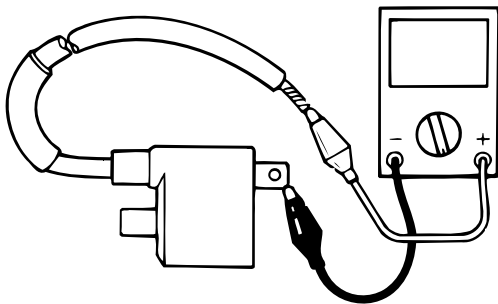

Secondary coil resistance
6.32 ~ 9.48 k Ω at 20 °C (68 °F)

- Is the ignition coil OK?

↓ YES

↓ NO

Replace the ignition coil.

5. Pickup coil resistance

- Disconnect the pickup coil coupler from the wire harness.
- Connect the pocket tester ($\Omega \times 100$) to the pickup coil terminal as shown.

Tester positive probe → white ①

Tester negative probe → red ②

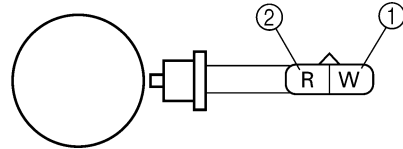

- Measure the pickup coil resistance.



Pickup coil resistance
656 ~ 984 Ω at 20 °C (68 °F)
(between white and red)

- Is the pickup coil OK?

↓ YES

↓ NO

Replace the pickup coil.

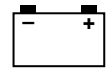

6. Source coil resistance

- Disconnect the source coil coupler from the wire harness.
- Connect the pocket tester ($\Omega \times 100$) to the source terminal as shown.

Tester positive probe → green ①

Tester negative probe → brown ②

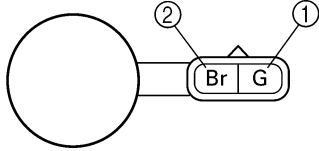

- Measure the source coil resistance.



Source coil resistance
 624 ~ 936 Ω at 20 °C (68 °F)
 (between green and brown)

- Is the source coil OK?



Replace the source coil assembly.

7. Main switch

- Check the main switch for continuity. Refer to “CHECKING THE SWITCHES”.
- Is the main switch OK?



Replace the main switch.

8. Engine stop switch

- Check the engine stop switch for continuity. Refer to “CHECKING THE SWITCHES”.
- Is the engine stop switch OK?

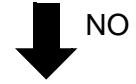
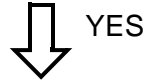

Replace the right handlebar switch.

9. Sidestand switch

- Check the sidestand switch for continuity. Refer to “CHECKING THE SWITCHES”.
- Is the sidestand switch OK?

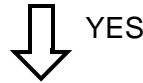

Replace the sidestand switch.

10. Wiring

- Check the entire ignition system’s wiring. Refer to “CIRCUIT DIAGRAM”.
- Is the ignition system’s wiring properly connected and without defects?



Properly connect or repair the ignition system’s wiring.

Replace the CDI unit.

**ELECTRIC STARTING SYSTEM
CIRCUIT DIAGRAM**

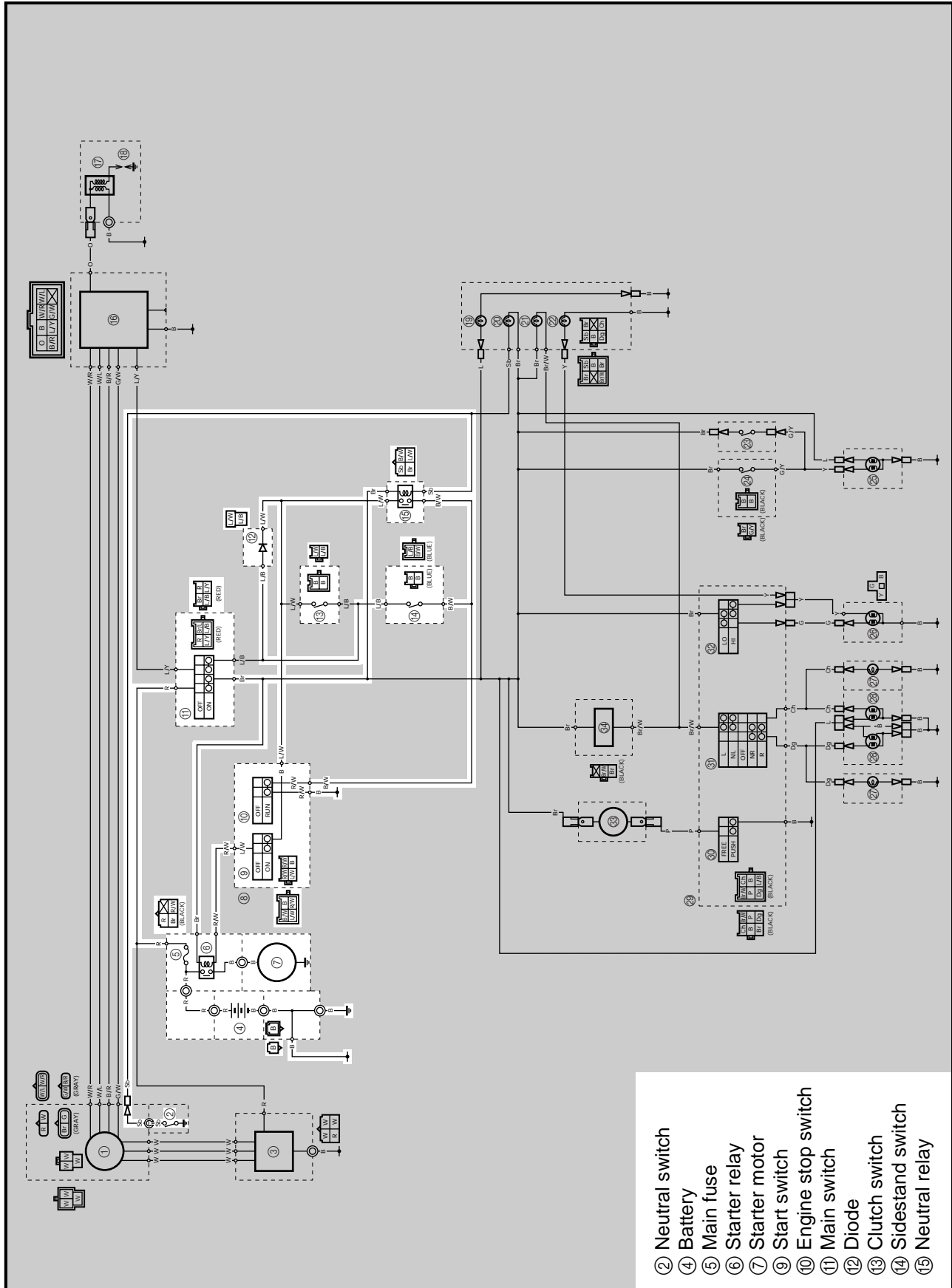

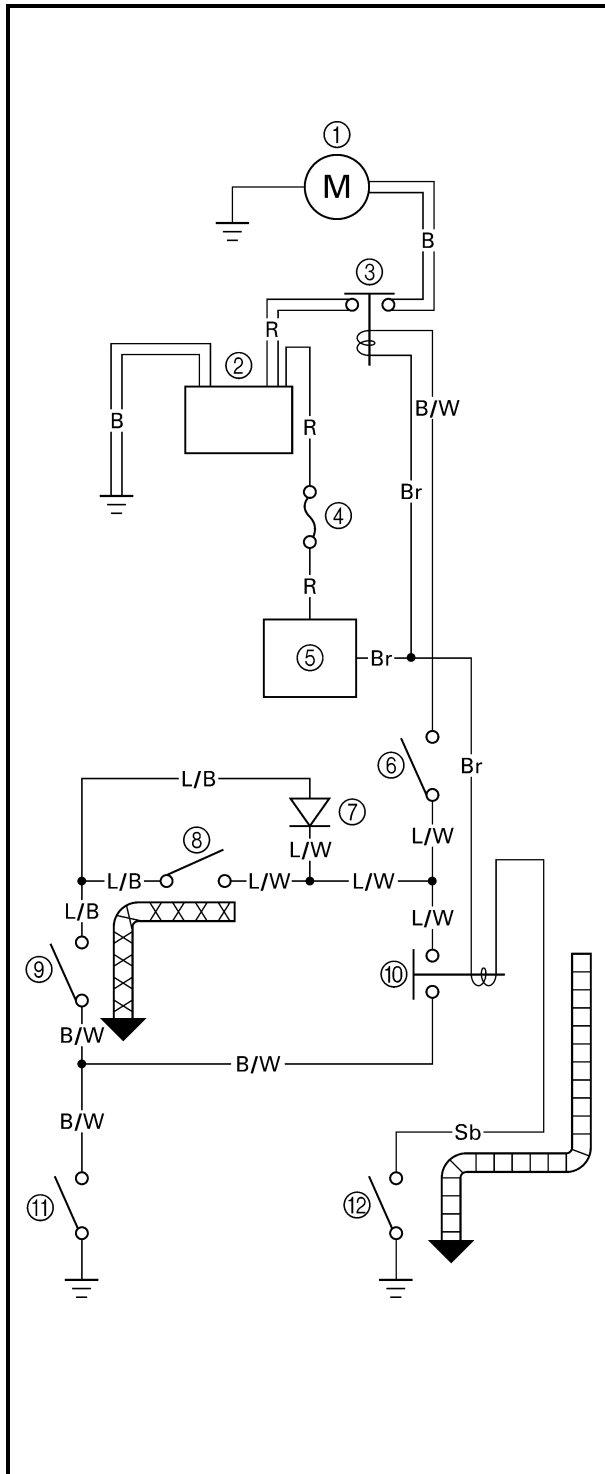

STARTING CIRCUIT CUT-OFF SYSTEM OPERATION

If the engine stop switch is set to “○” and the main switch is set to “ON” (both switches are closed), the starter motor can only operate if at least one of the following conditions is met:

- The transmission is in neutral (the neutral switch is closed).
- The clutch lever is pulled to the handlebar (the clutch switch is closed) and the sidestand is up (the sidestand switch is closed).

← WHEN THE TRANSMISSION IS IN NEUTRAL

← WHEN THE SIDESTAND IS UP AND THE CLUTCH LEVER IS PULLED TO THE HANDLEBAR

- ① Starter motor
- ② Battery
- ③ Starter relay
- ④ Main fuse
- ⑤ Main switch
- ⑥ Start switch
- ⑦ Diode
- ⑧ Clutch switch
- ⑨ Sidestand switch
- ⑩ Neutral relay
- ⑪ Engine stop switch
- ⑫ Neutral switch

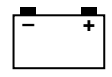

TROUBLESHOOTING

The starter motor fails to turn.

Check:

1. main fuse
2. battery
3. starter motor
4. neutral relay
5. diode
6. starter relay
7. main switch
8. engine stop switch
9. neutral switch
10. sidestand switch
11. clutch switch
12. start switch
13. wiring (of the entire starting system)

NOTE:

- Before troubleshooting, remove the following part(-s):
 - 1) rider seat
 - 2) fuel tank
 - 3) side cover (left and right)
- Troubleshoot with the following special tool(-s).



Pocket tester
YU-03112

1. Main fuse

- Check the main fuse for continuity.
- Are the main fuse OK?

↓ YES

↓ NO

Replace the fuse.

2. Battery

- Check the battery fluid level, battery terminal and specific gravity.



Specific gravity
1.280 at 20 °C (68 °F)

- Is the battery OK?

↓ YES

↓ NO

- Refill battery fluid.
- Clean the battery terminals.
- Recharge or replace the battery.

3. Starter motor

- Connect the battery positive terminal ① and starter motor lead ② with a jumper lead ③.

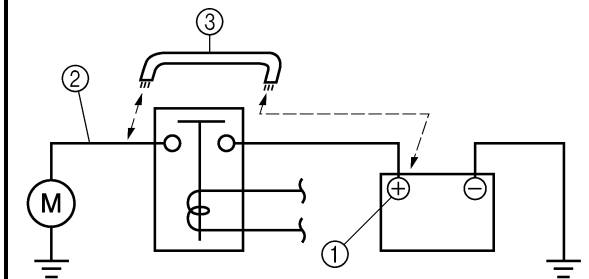

18210801

⚠ WARNING

- A wire that is used as a jumper lead must have at least the same capacity of the battery lead, otherwise the jumper lead may burn.
- This check is likely to produce sparks, therefore make sure that no flammable gas or fluid is in the vicinity.

- Does the starter motor turn?

↓ YES

↓ NO

Repair or replace the starter motor.

4. Neutral relay

- Remove the neutral relay from the wire harness.
- Connect the pocket tester ($\Omega \times 1$) and the battery (12 V) to the neutral relay terminals.
- Check the neutral relay for continuity.

Battery positive terminal → brown ①

Battery negative terminal → sky blue ②

Tester positive probe → blue/white ③

Tester negative probe → black/white ④

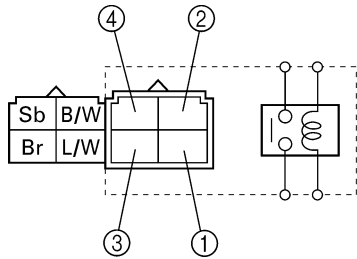

- Does the neutral relay have continuity between blue/white and black/white?

↓ YES

↓ NO

Replace the Neutral relay.

5. Diode

- Remove the diode from the wire harness.
- Connect the pocket tester ($\Omega \times 1$) to the diode terminals as shown.
- Check the diode for continuity.

Tester positive probe → blue/white ①	Continuity
Tester negative probe → blue/black ②	

Tester positive probe → blue/black ②	No continuity
Tester negative probe → blue/white ①	

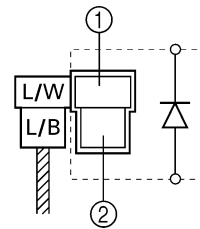

- Is the diode OK?

↓ YES

↓ NO

Replace the diode.

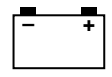

6. Starter relay

- Remove the starter relay from the wire harness.
- Connect the pocket tester ($\Omega \times 1$) and the battery (12 V) to the starter relay coupler as shown.
- Check the starter relay for continuity.

Battery positive terminal → brown ①

Battery negative terminal → red/white ②

Tester positive probe → red ③

Tester negative probe → black ④

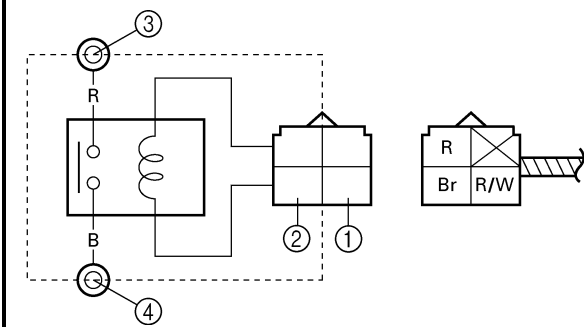

- Does the starter relay have continuity between red and black?

YES

NO

Replace the starter relay.

7. Main switch

- Check the main switch for continuity. Refer to "CHECKING THE SWITCHES".
- Is the main switch OK?

YES

NO

Replace the main switch.

8. Engine stop switch

- Check the engine stop switch for continuity. Refer to "CHECKING THE SWITCHES".
- Is the engine stop switch OK?

YES

NO

Replace the right handlebar switch.

9. Neutral switch

- Check the neutral switch for continuity. Refer to "CHECKING THE SWITCHES".
- Is the neutral switch OK?

YES

NO

Replace the neutral switch.

10. Sidestand switch

- Check the sidestand switch for continuity. Refer to "CHECKING THE SWITCHES".
- Is the sidestand switch OK?

YES

NO

Replace the side-stand switch.

11. Clutch switch

- Check the clutch switch for continuity. Refer to "CHECKING THE SWITCHES".
- Is the clutch switch OK?

YES

NO

Replace the clutch switch.

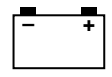

12. Start switch

- Check the start switch for continuity. Refer to "CHECKING THE SWITCHES".
- Is the start switch OK?

↓ YES

↓ NO

Replace the right handlebar switch.

13. Wiring

- Check the entire starting system's wiring. Refer to "CIRCUIT DIAGRAM".
- Is the starting system's wiring properly connected and without defects?

↓ NO

↓ YES

Properly connect or repair the starting system's wiring.

The starting system circuit is OK.

SIGNALING SYSTEM
CIRCUIT DIAGRAM

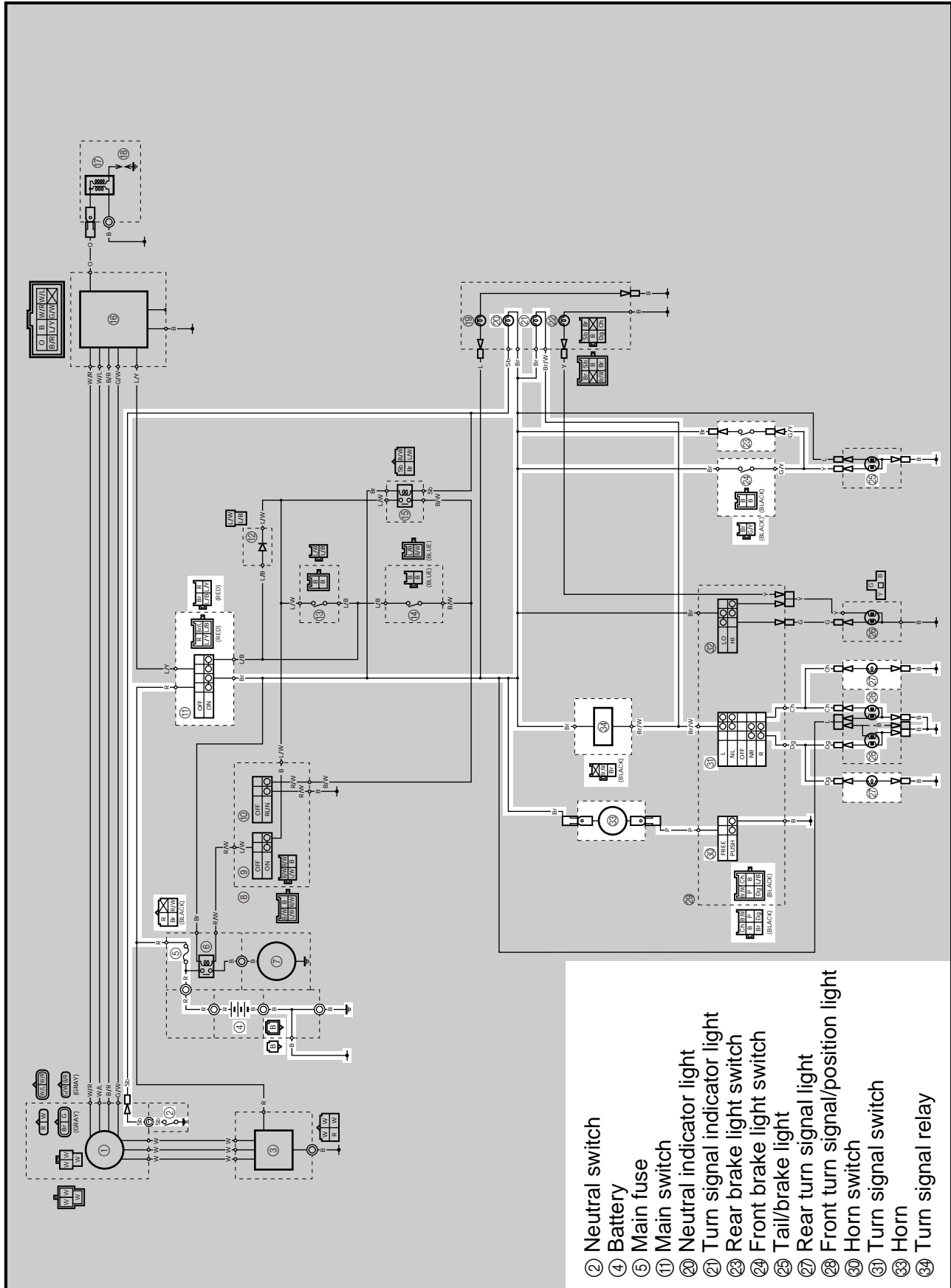

- ② Neutral switch
- ④ Battery
- ⑤ Main fuse
- ⑪ Main switch
- ⑫ Neutral indicator light
- ⑬ Turn signal indicator light
- ⑭ Rear brake light switch
- ⑮ Front brake light switch
- ⑯ Tail/brake light
- ⑰ Rear turn signal light
- ⑱ Front turn signal/position light
- ⑳ Horn switch
- ㉑ Turn signal switch
- ㉒ Horn
- ㉓ Turn signal relay

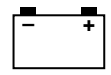

TROUBLESHOOTING

- Any of the following fail to light: turn signal light, brake light or an indicator light.
- The horn fails to sound.

Check:

1. main fuse
2. battery
3. main switch
4. wiring (of the entire signaling system)

NOTE:

- Before troubleshooting, remove the following part(-s):
 - 1) seats
 - 2) fuel tank
 - 3) side cover (left and right)
 - 4) headlight cover
 - 5) rear fender
- Troubleshoot with the following special tool (-s).

	Pocket tester YU-03112
---	-----------------------------------

1. Main fuse
 - Check the main fuse for continuity.
 - Are the main system fuse OK?



Replace the fuse.

2. Battery
 - Check the battery fluid level, battery terminal and specific gravity.



**Specific gravity
1.280 at 20 °C (68 °F)**

- Is the battery OK?



- Refill battery fluid.
- Clean the battery terminals.
- Recharge or replace the battery.

3. Main switch
 - Check the main switch for continuity. Refer to "CHECKING THE SWITCHES".
 - Is the main switch OK?



Replace the main switch.

4. Wiring
 - Check the entire signaling system's wiring. Refer to "CIRCUIT DIAGRAM".
 - Is the signaling system's wiring properly connected and without defects?



Check the condition of each of the signaling system's circuits. Refer to "CHECKING THE SIGNALING SYSTEM".

Properly connect or repair the signaling system's wiring.

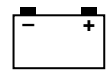

CHECKING THE SIGNALING SYSTEM

1. The horn fails to sound.

1. Horn switch

- Check the horn switch for continuity. Refer to “CHECKING THE SWITCHES”.
- Is the horn switch OK?



Replace the left handlebar switch.

2. Voltage

- Connect the pocket tester (DC 20 V) to the horn connector at the horn terminal as shown.

Tester positive probe → brown ①
 Tester negative probe → ground

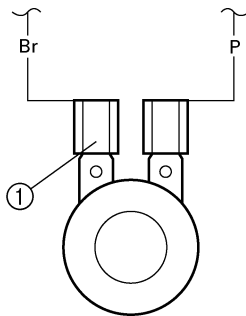

- Set the main switch to “ON”.
- Push the horn switch.
- Measure the voltage (12 V) of brown at the horn terminal.
- Is the voltage within specification?



The wiring circuit from the main switch to the horn connectors is faulty and must be repaired.

3. Horn

- Disconnect the pink connector at the horn terminal.
- Connect a jumper lead ① to the horn terminal and ground the jumper lead.
- Set the main switch to “ON”.
- Push the horn switch.
- Does the horn sound?

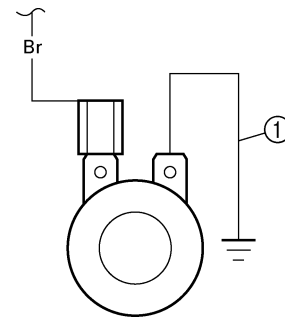

The horn is OK.

4. Voltage

- Connect the pocket tester (DC 20 V) to the horn connector at the pink terminal as shown.

Tester positive probe → pink ①
 Tester negative probe → ground

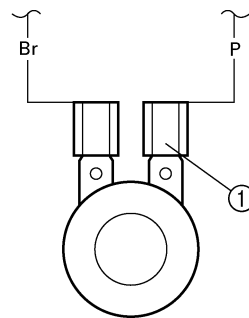

- Set the main switch to “ON”.
- Measure the voltage (12 V) of pink ① at the horn terminal.
- Is the voltage within specification?

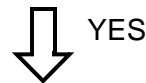

Repair or replace the horn.

Replace the horn.

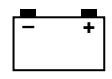

2. A tail/brake light fails to come on.

1. Tail/brake light bulb and socket

- Check the tail/brake light bulb and socket for continuity.
- Are the tail/brake light bulb and socket OK?

↓ YES

↓ NO

Replace the tail/brake light bulb, socket or both.

2. Brake light switches

- Check the brake light switches for continuity. Refer to "CHECKING THE SWITCHES".
- Is the brake light switch OK?

↓ YES

↓ NO

Replace the brake light switch.

3. Voltage

- Connect the pocket tester (DC 20 V) to the tail/brake light connectors (wire harness side) as shown.

Tester positive probe → yellow ①
Tester negative probe → black ②

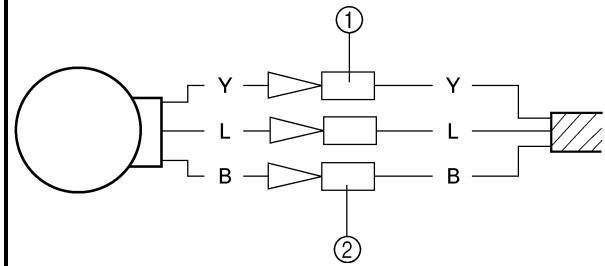

- Set the main switch to "ON".
- Pull in the brake lever or push down on the brake pedal.
- Measure the voltage (12 V) of yellow at the tail/brake light connector (wire harness side).
- Is the voltage within specification?

↓ YES

↓ NO

This circuit is OK.

The wiring circuit from the main switch to the tail/brake light connectors is faulty and must be repaired.

3. A turn signal light, turn signal indicator light or both fail to blink.

1. Turn signal light bulb and socket

- Check the turn signal light bulb and socket for continuity.
- Are the turn signal light bulb and socket OK?

↓ YES

↓ NO

Replace the turn signal light bulb, socket or both.

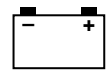

2. Turn signal indicator light bulb and socket

- Check the turn signal indicator light bulb and socket for continuity.
- Are the turn signal indicator light bulb and socket OK?

YES

NO

Replace the meter assembly.

3. Turn signal switch

- Check the turn signal switch for continuity. Refer to "CHECKING THE SWITCHES".
- Is the turn signal switch OK?

YES

NO

Replace the left handlebar switch.

4. Voltage

- Connect the pocket tester (DC 20 V) to the turn signal relay coupler (wire harness side) as shown.

Tester positive probe → brown ①
 Tester negative probe → ground

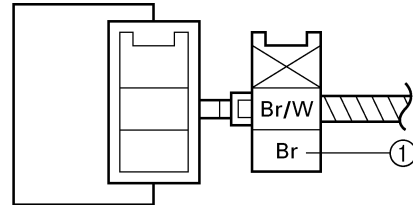

- Set the main switch to "ON".
- Measure the voltage (12 V) of brown ① at the turn signal relay coupler (wire harness side).
- Is the voltage within specification?

YES

NO

The wiring circuit from the main switch to the turn signal relay coupler (turn signal relay side) is faulty and must be repaired.

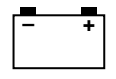

5. Voltage

- Connect the pocket tester (DC 20 V) to the turn signal relay coupler (wire harness side) as shown.

Tester positive probe → brown/white ①
 Tester negative probe → ground

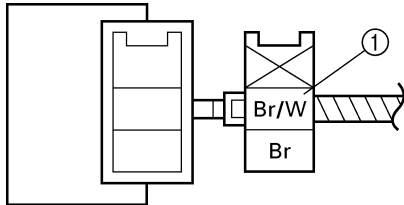

- Set the main switch to "ON".
- Set the turn signal switch to "←" or "→".
- Measure the voltage (12 V) of brown/white ① at the turn signal relay coupler (wire harness side).
- Is the voltage within specification?



The turn signal relay is faulty and must be replaced.

6. Voltage

- Connect the pocket tester (DC 20 V) to the turn signal light connectors or the meter assembly coupler (wire harness side) as shown.

- Ⓐ Turn signal light
- Ⓑ Turn signal indicator light

Left turn signal light

Tester positive probe → chocolate ①
 Tester negative probe → ground

Right turn signal light

Tester positive probe → dark green ②
 Tester negative probe → ground

Turn indicator light

Tester positive probe → brown ③
 Tester negative probe → ground

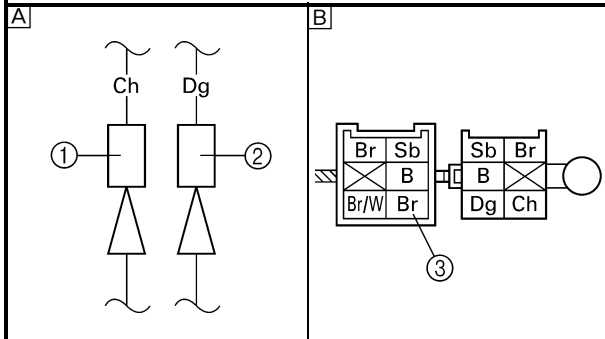

- Set the main switch to "ON".
- Set the turn signal switch to "←" or "→".
- Measure the voltage (12 V) of chocolate ① or dark green ② at the turn signal light connectors wire harness side).
- Is the voltage within specification?



This circuit is OK.

The wiring circuit from the turn signal switch to the turn signal light connectors is faulty and must be repaired.

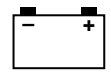

4. The neutral indicator light fails to come on.

1. Neutral indicator light bulb and socket

- Check the neutral indicator light bulb and socket for continuity.
- Are the neutral indicator light bulb and socket OK?

↓ YES

↓ NO

Replace the meter assembly.

2. Neutral switch

- Check the neutral switch for continuity. Refer to "CHECKING THE SWITCHES".
- Is the neutral switch OK?

↓ YES

↓ NO

Replace the neutral switch.

3. Voltage

- Connect the pocket tester (DC 20 V) to the meter assembly coupler (wire harness side) as shown.

Tester positive probe → brown ①

Tester negative probe → sky blue ②

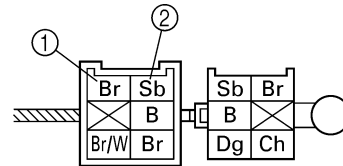

- Set the main switch to "ON".
- Measure the voltage (12 V) of brown ① and sky blue ② at the meter assembly coupler.
- Is the voltage within specification?

↓ YES

↓ NO

This circuit is OK.

The wiring circuit from the main switch to the meter light bulb coupler is faulty and must be repaired.



YAMAHA MOTOR CO., LTD.
2500 SHINGAI IWATA SHIZUOKA JAPAN

PRINTED IN U.S.A.

TW200EN/TW200ENC WIRING DIAGRAM

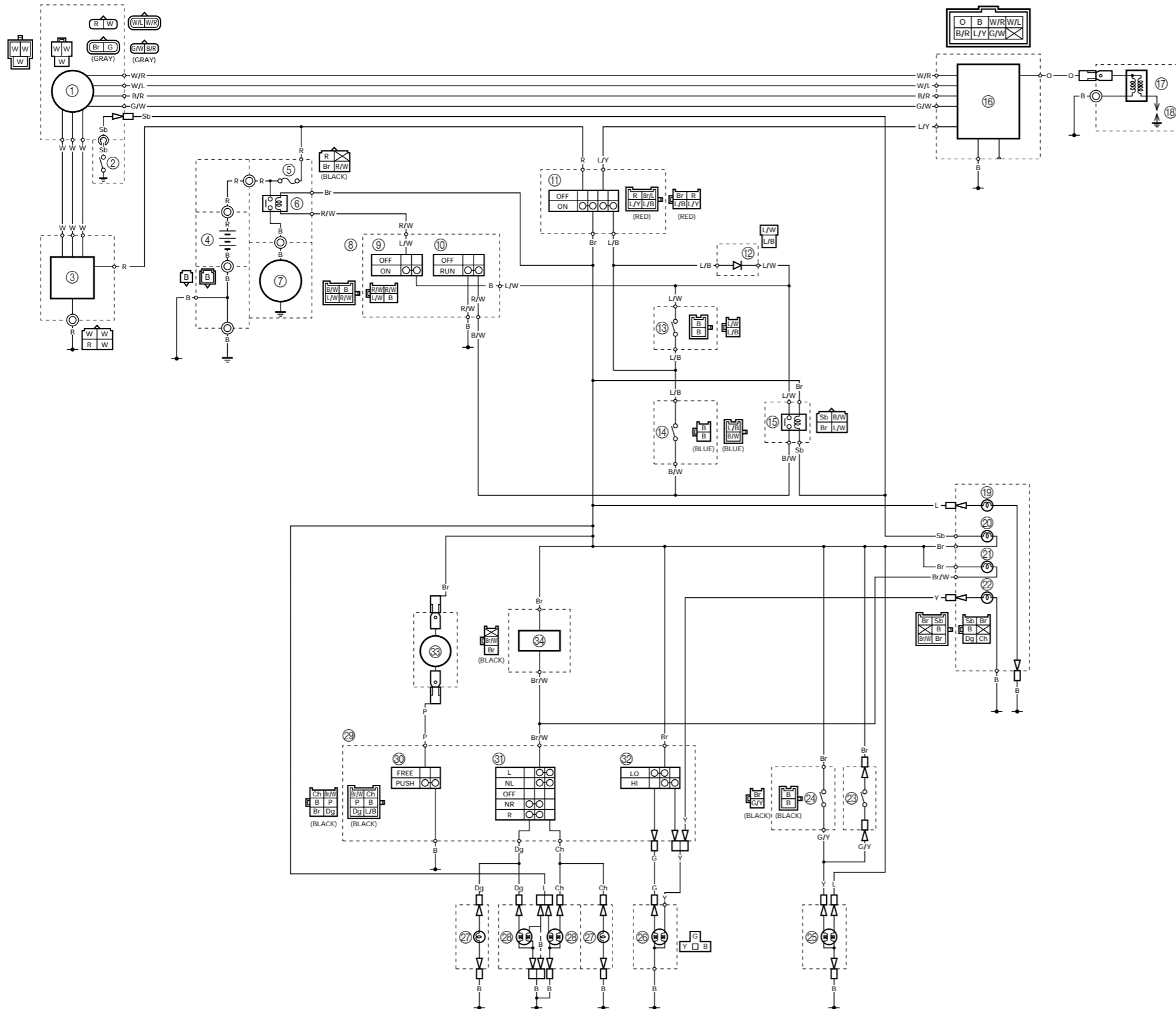

- ① AC magneto
- ② Neutral switch
- ③ Rectifier/regulator
- ④ Battery
- ⑤ Main fuse
- ⑥ Starter relay
- ⑦ Starter motor
- ⑧ Right handlebar switch
- ⑨ Start switch
- ⑩ Engine stop switch
- ⑪ Main switch
- ⑫ Diode
- ⑬ Clutch switch
- ⑭ Sidestand switch
- ⑮ Neutral relay
- ⑯ CDI unit
- ⑰ Ignition coil
- ⑱ Spark plug
- ⑲ Meter light
- ⑳ Neutral indicator light
- ㉑ Turn signal indicator light
- ㉒ High beam indicator light
- ㉓ Rear brake light switch
- ㉔ Front brake light switch
- ㉕ Tail/brake light
- ㉖ Headlight
- ㉗ Rear turn signal light
- ㉘ Front turn signal/position light
- ㉙ Left handlebar switch
- ㉚ Horn switch
- ㉛ Turn signal switch
- ㉜ Dimmer switch
- ㉝ Horn
- ㉞ Turn signal relay

COLOR CODE

Bblack	O orange	B/R.....black/red	L/W blue/white
Brbrown	P..... pink	B/W.....brake/white	L/Y blue/yellow
Chchocolate	R..... red	Br/W.....brown/white	R/L red/blue
Dgdark green	Sb..... sky blue	G/Wgreen/white	R/W red/white
G.....green	W..... white	G/Ygreen/yellow	W/L white/blue
L.....blue	Y..... yellow	L/Bblue/black	W/R white/red