

SONY®

3-081-837-14(1)

Digital Still Camera

Operating Instructions

Before operating the unit, please read this manual thoroughly, and retain it for future reference.

Owner's Record

The model and serial numbers are located on the bottom. Record the serial number in the space provided below. Refer to these numbers whenever you call upon your Sony dealer regarding this product.

Model No. MVC-CD500

Serial No. _____

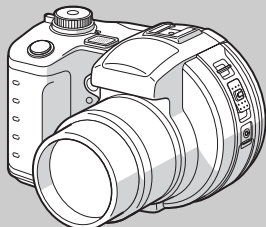

MVC-CD500

CDMavica



Getting started _____

Shooting still images _____

Viewing still images _____

Deleting still images _____

Before advanced operations _____

Advanced still image shooting _____

Advanced still image viewing _____

Still image editing _____

Enjoying movies _____

Enjoying images on your computer _____

Troubleshooting _____

Additional information _____

Index _____

WARNING

To prevent fire or shock hazard, do not expose the unit to rain or moisture.

CAUTION

The use of optical instruments with this product will increase eye hazard. Use of controls or adjustments or performance of procedures other than those specified herein may result in hazardous radiation exposure.

For the Customers in the U.S.A.

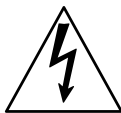
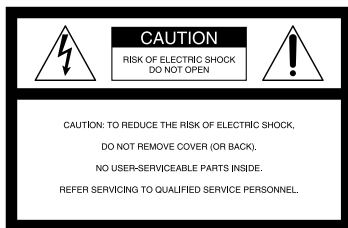

This symbol is intended to alert the user to the presence of uninsulated "dangerous voltage" within the product's enclosure that may be of sufficient magnitude to constitute a risk of electric shock to persons.



This symbol is intended to alert the user to the presence of important operating and maintenance (servicing) instructions in the literature accompanying the appliance.

If you have any questions about this product, you may call:

Sony Customer Information Center
1-800-222-SONY (7669)

The number below is for the FCC related matters only.

Regulatory Information

Declaration of Conformity

Trade Name: SONY
Model No.: MVC-CD500
Responsible Party: Sony Electronics Inc.
Address: 16450 W. Bernardo Dr,
San Diego, CA 92127
U.S.A.
Telephone No.: 858-942-2230

This device complies with Part 15 of the FCC Rules. Operation is subject to the following two conditions: (1) This device may not cause harmful interference, and (2) this device must accept any interference received, including interference that may cause undesired operation.

CAUTION

You are cautioned that any changes or modifications not expressly approved in this manual could void your authority to operate this equipment.

Notes:

- This equipment has been tested and found to comply with the limits for a Class B digital device, pursuant to Part 15 of the FCC Rules. These limits are designed to provide reasonable protection against harmful interference in a residential installation. This equipment generates, uses, and can radiate radio frequency energy and, if not installed and used in accordance with the instructions, may cause harmful interference to radio communications. However, there is no guarantee that interference will not occur in a particular installation. If this equipment does cause harmful interference to radio or television reception, which can be determined by turning the equipment off and on, the user is encouraged to try to correct the interference by one or more of the following measures:
 - Reorient or relocate the receiving antenna.
 - Increase the separation between the equipment and receiver.
 - Connect the equipment into an outlet on a circuit different from that to which the receiver is connected.
 - Consult the dealer or an experienced radio/TV technician for help.

The shielded interface cable recommended in this manual must be used with the equipment in order to comply with the limits for a digital device pursuant to Subpart B of Part 15 of FCC Rules.

- This product contains mercury. Disposal of this product may be regulated if sold in the United States. For disposal or recycling information, please contact your local authorities or the Electronics Industries Alliance (<http://www.eiae.org>).

For the Customers in the U.S.A. and Canada

RECYCLING LITHIUM-ION BATTERIES

Lithium-Ion batteries are recyclable.

You can help preserve our environment by returning your used rechargeable batteries to the collection and recycling location nearest you.



For more information regarding recycling of rechargeable batteries, call toll free 1-800-822-8837, or visit <http://www.rbrc.org/>



Caution: Do not handle damaged or leaking Lithium-Ion batteries.

CAUTION

TO PREVENT ELECTRIC SHOCK, DO NOT USE THIS POLARIZED AC PLUG WITH AN EXTENSION CORD, RECEPTACLE OR OTHER OUTLET UNLESS THE BLADES CAN BE FULLY INSERTED TO PREVENT BLADE EXPOSURE.

Notice on the supplied AC Adaptor for the customers in the United Kingdom

A moulded plug complying with BS 1363 is fitted to this equipment for your safety and convenience.

Should the fuse in the plug supplied need to be replaced, a 5 AMP fuse approved by ASTA or BSI to BS 1362, (i.e., marked with  or ) must be used.

If the plug supplied with this equipment has a detachable fuse cover, be sure to attach the fuse cover after you change the fuse. Never use the plug without the fuse cover. If you should lose the fuse cover, please contact your nearest Sony service station.

Attention for the Customers in Europe

This product has been tested and found compliant with the limits sets out in the EMC Directive for using connection cables shorter than 3 meters (9.8 feet).

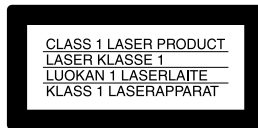

This statement is indicated under the lens.

Attention

The electromagnetic field at the specific frequencies may influence the picture and sound of this camera.

Notice

If static electricity or electromagnetism causes data transfer to discontinue midway (fail), restart the application or disconnect and connect the USB cable again.

Notice

Certain countries may regulate disposal of the battery used to power this product. Please consult with your local authority.

Before using your camera

This digital still camera uses 8 cm CD-Rs/CD-RWs as recording media. “CD-R” or “CD-RW” mentioned above is indicated as “disc” in this manual. When a distinction between CD-Rs and CD-RWs is necessary, “disc” is indicated as “CD-R” or “CD-RW.”

Refer to page 18 for discs that can be used with this camera, and page 120 for precautions on handling discs.

- We recommend that you use this camera with Mavica discs*.
- While the image is being read from or written to the disc, the ACCESS lamp flashes (red). When this lamp is lit, do not shake or strike the camera.

* The Mavica disc is an 8 cm CD-R/CD-RW with the Mavica logo.

Trial recording

Before you record one-time events, you may want to make a trial recording to make sure that the camera is working correctly.

No compensation for contents of the recording

Contents of the recording cannot be compensated for if recording or playback is not possible due to a malfunction of your camera or recording media, etc.

Back up recommendation

To avoid the potential risk of data loss, always copy (back up) data to a disk.

Notes on image data compatibility

- This camera conforms with the Design rule for Camera File system universal standard established by the JEITA (Japan Electronics and Information Technology Industries Association).
- Playback of images recorded with your camera on other equipment and playback of images recorded or edited with other equipment on your camera are not guaranteed.

Precaution on copyright

Television programs, films, video tapes, and other materials may be copyrighted. Unauthorized recording of such materials may be contrary to the provision of the copyright laws.

Do not shake or strike the camera

In addition to malfunctions and inability to record images, this may render the discs unusable or image data breakdown, damage or loss may occur.

LCD screen, LCD finder (only models with an LCD finder) and lens

- The LCD screen and the LCD finder are manufactured using extremely high-precision technology so over 99.99% of the pixels are operational for effective use. However, there may be some tiny black points and/or bright points (white, red, blue or green in color) that constantly appear on the LCD screen and the LCD finder. These points are normal in the manufacturing process and do not affect the recording in any way.
- Be careful when placing the camera near a window or outdoors. Exposing the LCD screen, the finder or the lens to direct sunlight for long periods may cause malfunctions.
- Do not press the LCD screen hardily. The screen may be uneven and that may cause a malfunction.
- Images may be trailed on the LCD screen in a cold location. This is not a malfunction.

Clean the flash surface before use

The heat of flash emission may cause dirt on the flash surface to become discolored or to stick to the flash surface, resulting in insufficient light emission.

Do not get the camera wet

When taking pictures outdoors in the rain or under similar conditions, be careful not to get the camera wet. If moisture condensation occurs, see page 120 and follow the instructions on how to remove it before using the camera.

Do not expose the camera to sand or dust

Using the camera in sandy or dusty locations may cause malfunction.

Do not aim the camera at the sun or other bright light

This may cause irrecoverable damage to your eyes. Or it may cause the malfunction of your camera.

Notes on the camera locations

- Do not use the camera near a location that generates strong radio wave or emits radiation. The camera may not be able to record or play back properly.
- Do not use the camera near a TV, radio, tuner. Noise may be caused on the camera.

The pictures used in this manual

The photographs used as examples of pictures in this manual are reproduced images, and are not actual images shot using this camera.

Handling of the movable lens

This camera uses a movable lens. Be careful not to strike or apply excessive force to the lens portion.

Trademarks

- “InfoLITHIUM” is a trademark of Sony Corporation.
- Microsoft and Windows are registered trademarks of the U.S. Microsoft Corporation in the United States and other countries.
- Macintosh and Mac OS are trademarks or registered trademarks of Apple Computer, Inc.
- Pentium is a trademark or a registered trademark of Intel Corporation.
- In addition, system and product names used in this manual are, in general, trademarks or registered trademarks of their respective developers or manufacturers. However, the TM or ® marks are not used in all cases in this manual.

About the Carl Zeiss lens

This camera is equipped with a Carl Zeiss lens which is capable of reproducing fine images. The lens for this camera uses the MTF* measurement system for cameras developed jointly by Carl Zeiss, in Germany, and Sony Corporation, and offers the same quality as other Carl Zeiss lenses.

* MTF is an abbreviation of Modulation Transfer Function, a numeric value indicating the amount of light from a specific part of the subject gathered at the corresponding position in the image.

Table of contents

Before using your camera	4
Introduction	8
Identifying the parts	9

Getting started

Charging the battery pack	11
Using an external power source	14
Using your camera abroad	14
Turning on/off your camera	15
How to use the control button	15
Setting the date and time	16

Shooting still images

Inserting and removing a disc	18
Initializing a disc	19
What is initialization?	19
Setting the still image size	20
Image size and quality	21
Basic still image shooting	
— Auto adjustment mode	22
Checking the last image you shot	
— Quick Review	24
Using the zoom feature	25
Shooting close-ups — Macro	26
Using the self-timer	27
Selecting a flash mode	27
Indicators on the screen during shooting	30
Inserting the date and time on a still image	31

Viewing still images

Viewing images on the LCD screen of your camera	32
Viewing images on a TV screen	34

Deleting still images

Deleting images	36
Formatting a CD-RW	39

Before advanced operations

How to setup and operate your camera ..	41
Changing the menu settings	41
Changing the items in the SET UP screen	41
How to use the jog dial	42
Deciding the still image quality	43
Creating or selecting a folder	43
Creating a new folder	44
Changing the recording folder	44

Advanced still image shooting

Shooting with Program Shift	
— Program Shift	45
Shooting with the manual adjustments ..	45
Shutter speed priority mode	46
Aperture priority mode	47
Manual exposure mode	47
Choosing an auto focus method	47

Choosing a focus range finder frame	
— AF range finder	48
Choosing a focus operation	
— AF Mode	49
Setting the distance to the subject	
— Focus preset	50
Adjusting the exposure	
— EV adjustment	51
Displaying a histogram	52
Selecting the metering mode	53
Shooting with the exposure fixed	
— AE LOCK	54
Shooting three images with the exposure shifted — Exposure Bracket	55
Adjusting color tones	
— White Balance	57
Adjusting the flash level	
— Flash Level	58
Shooting multiple frames	
— Clip Motion	59
Shooting in Multi Burst mode	
— Multi Burst	60
Shooting three images continuously	
— Burst 3	61
Shooting still images in TIFF mode	
— TIFF	62
Shooting still images for e-mail	
— E-Mail	62
Shooting still images with audio files	
— Voice	63

Shooting according to scene conditions	
— Scene Selection	64
Adding special effects	
— Picture Effect	65
Confirming whether to record images	
— Confirm before write	66
Using an external flash	67
Using the Sony HVL-F32X Flash	67
Using the Sony HVL-F1000 Flash	68
Using a commercially available external flash	68

Advanced still image viewing

Selecting the folder and playing back images — Folder	69
Enlarging a portion of a still image	70
Enlarging an image	
— Playback zoom	70
Recording an enlarged image	
— Trimming	71
Playing back successive images	
— Slide Show	71
Rotating still images	
— Rotate	72
Playing back images shot in Multi Burst mode	73
Playing back continuously	73
Playing back frame by frame	
— Jog playback	73

Still image editing

Protecting images — Protect	75
Changing image size — Resize	77
Choosing images to print	
— Print (DPOF) mark	77

Enjoying movies

Shooting movies	80
Viewing movies on the LCD screen	81
Deleting movies — Delete	82

Enjoying images on your computer

Viewing images on your computer	
— Introduction	84
Viewing images using CD-ROM drive ..	85
Finalizing a disc	85
What is finalization?	85
Canceling finalization (Unfinalize) (CD-RW only)	86
Using the supplied 8cm CD adapter ..	87
Viewing images through a CD-ROM drive	88
Image file storage destinations and image file names	89
Copying images into your computer	
through a USB connection	91
Installing the PTP Manager	91
Installing “ImageMixer”	92

Connecting the camera to your computer	93
Copying images	94
When the PTP Manager does not start up	95
Copying images using the Windows XP AutoPlay Wizard	96
Viewing images on your computer	96
Creating a Video CD	96
For Mac OS X users	
(v10.0/v10.1/v10.2)	97

Troubleshooting

Troubleshooting	98
Warnings and messages	107
Self-diagnosis display	109

Additional information

Number of images that can be saved or shooting time	110
Menu items	112
SET UP items	116
Precautions	119
On discs	120
On “InfoLITHIUM” battery pack	121
Specifications	123
The LCD screen	125

Index

Index	129
-------------	-----

Introduction

This digital still camera is capable of recording still images and movies onto 8 cm CD-R/CD-RW discs.

Capture images with your computer

You can easily copy images onto your computer through a CD-ROM drive or the USB cable, and view and modify images on your computer using application software. When using a CD-ROM drive to view images on your computer, finalization is required (page 85).

Flow chart for disc operations

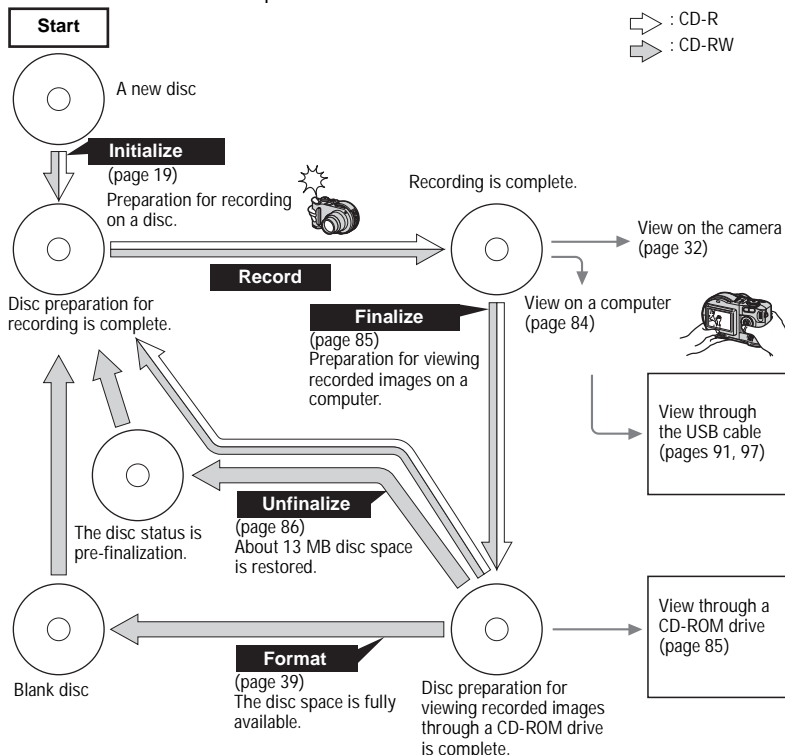

Identifying the parts

See the pages in parentheses for details of operation.

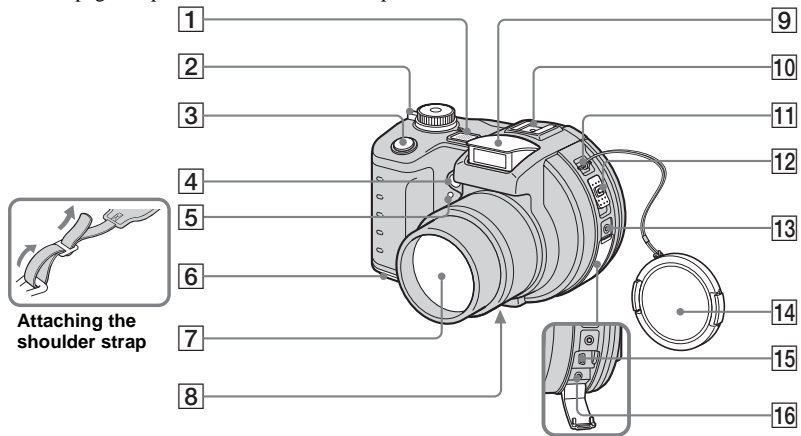

- 1** Microphone
- 2** **POWER ON/OFF (CHG)** switch (15)
- 3** **Shutter button** (22)
- 4** **Hologram AF emitter** (29, 116)
- 5** **Self-timer lamp** (27)
- 6** **Battery cover** (11)
- 7** **Lens**
- 8** **Tripod receptacle (bottom surface)**

- 9** **Flash emitter** (27)
- 10** **Advanced accessory shoe** (67)
- 11** **Hook for lens cap/shoulder strap**
- 12** **Disc cover OPEN lever** (18)
- 13** **ACC (Accessory) jack** (67)
- 14** **Lens cap**
- 15** **ψ (USB) jack** (93)
- 16** **A/V OUT (MONO) jack** (34)

- Use a tripod with a screw length of less than 5.5 mm (7/32 inch). You will be unable to firmly secure the camera to tripods having longer screws, and may damage the camera.
- Use ACC jack to connect an external flash or other equipment.
- Do not touch the microphone while recording.

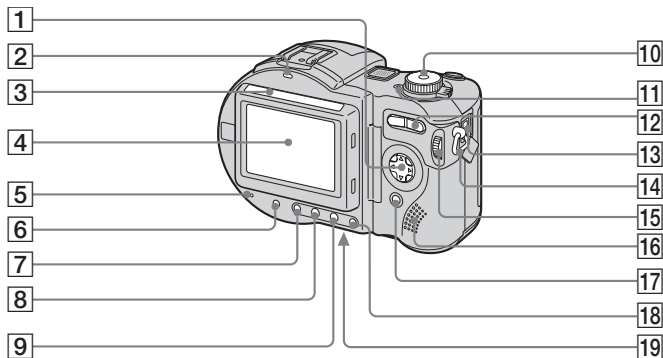

- 1 **Control button**
(Menu on) (▲/▼/◀/▶/●)
(Menu off) (⚡/☺/☹/☺) (27, 27, 24,
26)
- 2 **⚡/CHG (charge) lamp** (12)
- 3 **Photocell window for LCD
screen**
- 4 **LCD screen**
- 5 **ACCESS lamp** (18)
- 6 **DISPLAY/LCD BACK LIGHT ON/
OFF button** (30)
- 7 **AE LOCK button** (54)
- 8 **FOCUS button** (47, 50)
- 9 **☑ (Exposure) button** (51)

- 10 **Mode dial** (16)
 - 📷: To shoot still images in auto
adjustment mode
 - P: To shoot still images in
programmed mode
 - S: To shoot in the shutter speed
priority mode
 - A: To shoot in the aperture
priority mode
 - M: To shoot in the manual
exposure mode
 - SCN: To shoot in the Scene
Selection mode
 - SET UP: To set the SET UP items

🎬: To shoot movies, Clip
Motion images or Multi
Burst mode images

▶: To view or edit images

- 11 **POWER lamp** (15)
- 12 **Zoom button (for shooting)** (25)/
Index button (for viewing) (33)
- 13 **DC IN jack** (11, 14)
- 14 **Hook for shoulder strap**
- 15 **Jog dial** (42)
- 16 **Speaker**
- 17 **MENU button** (41, 112)
- 18 **📷/🗑 (Image Size/Delete)
button** (20, 36)
- 19 **RESET button (bottom surface)**
(98)

- The LCD screen automatically becomes
brighter when photocell window for LCD
screen is exposed to sunlight.

Charging the battery pack

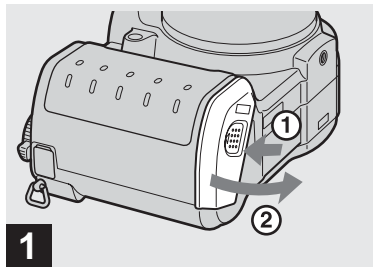

➔ Open the battery cover.

Slide the cover in the direction of the arrow.

- **Be sure to turn off your camera when charging the battery pack (page 15).**
- Your camera operates only with the “InfoLITHIUM” NP-FM50 battery pack (M series) (supplied) (page 121).

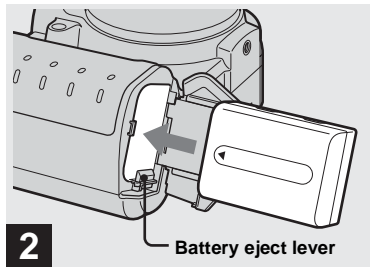

➔ Install the battery pack, then close the battery cover.

Insert the battery pack with the ◀ mark facing toward the battery compartment as illustrated.

Make sure the battery pack is firmly inserted all the way, then close the cover.

- The battery pack is easily inserted by pushing the battery eject lever at the front of the battery compartment up.

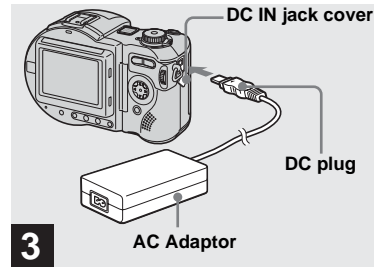

➔ Open the DC IN jack cover and connect the AC Adaptor (supplied) to the DC IN jack of your camera.

Connect the DC plug with the ▲ mark facing up.

- Do not short the DC plug of the AC Adaptor with a metallic object, as this may cause malfunction.
- Clean the DC plug of the AC Adaptor with a dry cotton bud. Do not use the dirty plug. Use of the dirty plug may not properly charge the battery pack.

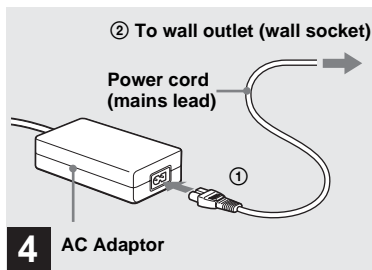

- 4 AC Adaptor**
- ➔ **Connect the power cord (mains lead) to the AC Adaptor and then to a wall outlet (wall socket).**

The ζ /CHG lamp (orange) lights up when charging begins, and goes off when charging is completed.

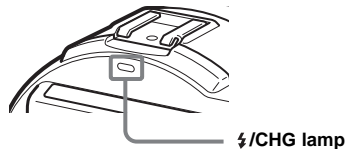

- After charging the battery pack, disconnect the AC Adaptor from the DC IN jack of your camera.

To remove the battery pack

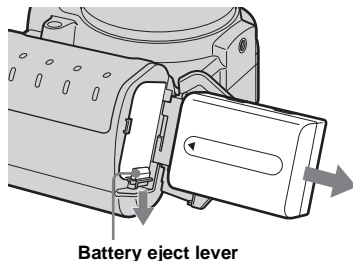

Open the battery cover. Slide the battery eject lever in the direction of the arrow, and remove the battery pack.

- Be careful not to drop the battery pack when removing it.

Battery remaining indicator

The battery remaining indicator on the LCD screen shows the remaining shooting or viewing time.

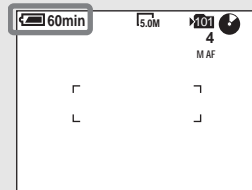

- The black portion of the battery remaining indicator in the illustration shows the actual remaining time.
- The displayed remaining time may not be correct under certain circumstances or conditions.

Charging time

Approximate time to charge a completely discharged battery pack using the AC Adaptor at a temperature of 25°C (77°F).

Battery pack	Charging time (min.)
NP-FM50 (supplied)	Approx. 150

Number of images and battery life that can be recorded/viewed

The tables show the approximate number of images and the battery life that can be recorded/viewed when you shoot images in normal mode with a fully charged battery pack at a temperature of 25°C (77°F). The numbers of images that can be recorded or viewed take into account changing the supplied disc as necessary. Note that the actual numbers may be less than indicated depending on the conditions of use.

Shooting still images Under the average conditions¹⁾

Image size	NP-FM50 (supplied)	
	No. of images	Battery life (min.)
5.0M	Approx. 220	Approx. 110
VGA	Approx. 250	Approx. 125

- ¹⁾ Shooting in the following situations:
- [P. Quality] is set to [Fine]
 - Shooting one time every 30 seconds
 - The zoom is switched alternately between the W and T ends
 - The flash strobes once every two times
 - The power turns on and off once every ten times
 - [AF Mode] is set to [Monitor] in the SET UP settings

Viewing still images²⁾

Image size	NP-FM50 (supplied)	
	No. of images	Battery life (min.)
5.0M	Approx. 1900	Approx. 160
VGA	Approx. 2000	Approx. 170

- ²⁾ Viewing single images in order at about five second intervals

Shooting movies³⁾

	NP-FM50 (supplied)
	Battery life (min.)
Continuous shooting	Approx. 130

- ³⁾ Shooting continuously at 160 (Mail) image size
- The number of images and the battery life that can be recorded/viewed are decreased under the following conditions:
 - The surrounding temperature is low
 - The flash is used
 - The camera has been turned on and off many times
 - The zoom is used frequently
 - [LCD Backlight] is set to [Bright] in the SET UP settings
 - The battery power is low. The battery capacity decreases as you use it more and more and as time passes (page 122).
 - [AF Mode] is set to [Cont] in the SET UP settings

Using an external power source

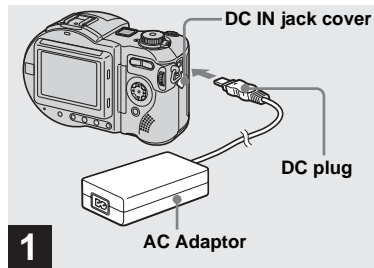

- ➔ **Open the DC IN jack cover and connect the AC Adaptor (supplied) to the DC IN jack of your camera.**

Connect the DC plug with the ▲ mark facing up.

- Connect the AC Adaptor to an easily accessible wall outlet (wall socket) close by. If any trouble occurs while using the adaptor, immediately shut off the power by disconnecting the plug from the wall outlet (wall socket).

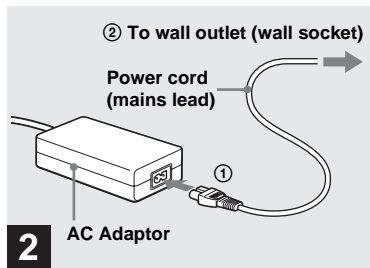

- ➔ **Connect the power cord (mains lead) to the AC Adaptor and then to a wall outlet (wall socket).**

- When you have finished using the AC Adaptor, disconnect it from the DC IN jack of the camera.
- The set is not disconnected from the AC power source (mains) as long as it is connected to the wall outlet (wall socket), even if the unit itself has been turned off.
- Do not use the AC Adaptor placed in a narrow space, such as between a wall and furniture.

Using your camera abroad

Power sources

You can use your camera in any country or region with the supplied AC Adaptor within 100 V to 240 V AC, 50/60 Hz. Use a commercially available AC plug adaptor [a], if necessary, depending on the design of the wall outlet (wall socket) [b].

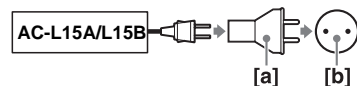

- Do not use an electronic transformer (travel converter), as this may cause a malfunction.

Turning on/off your camera

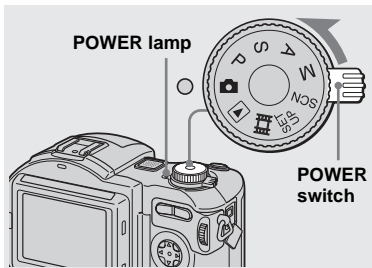

➔ Slide the **POWER switch** in the direction of the arrow.

The POWER lamp (green) lights up and the power is on. When you turn on your camera for the first time, the Clock Set screen appears (page 16).

Turning off the power

Slide the POWER switch in the direction of the arrow again. The POWER lamp goes out, and the camera turns off.

- Do not remove the battery pack or the AC Adaptor with the lens portion extended, as this may cause malfunction.
- If you turn on the power when the mode dial is set to , P, S, A, M, SCN or , the lens portion moves. Do not touch the lens portion while it is operating.

Auto power-off function

If you do not operate the camera for about three minutes during shooting or viewing or when performing SET UP, the camera turns off automatically to prevent wearing down the battery. The auto power-off function only operates when the camera is operating using a battery pack. The auto power-off function also will not operate in the following circumstances.

- When viewing movies
- When a connector is plugged into the (USB) jack or the A/V OUT (MONO) jack.

How to use the control button

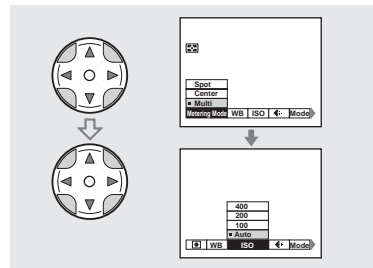



To change the current settings of the camera, bring up the menu or the SET UP screen (page 41), and use the control button to make the changes.

For each item, press /// to select the desired value, then press the center or /// to make the setting.

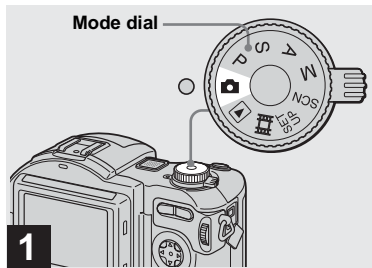
Setting the date and time



➔ Set the mode dial to .

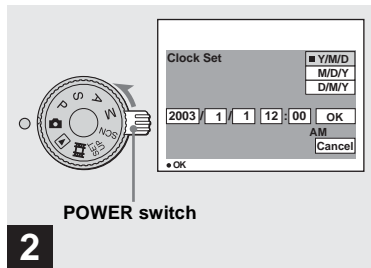

- You can also carry out this operation when the mode dial is set to P, S, A, M, SCN,  or .
- To change the date and time, set the mode dial to SET UP, select [Clock Set] in  (Setup 1) (page 118), and perform the procedure from step **3**.

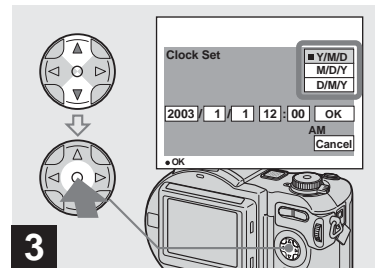

➔ Slide the POWER switch in the direction of the arrow to turn on the power.

The POWER lamp (green) lights up and the Clock Set screen appears on the LCD screen.



➔ Select the desired date display format with / on the control button, then press .

Select from [Y/M/D] (year/month/day), [M/D/Y] (month/day/year) or [D/M/Y] (day/month/year).

- If the rechargeable button battery, which provides the power for saving the time data, is ever fully discharged (page 120), the Clock Set screen will appear again. When this happens, reset the date and time, by starting from step **3** above.

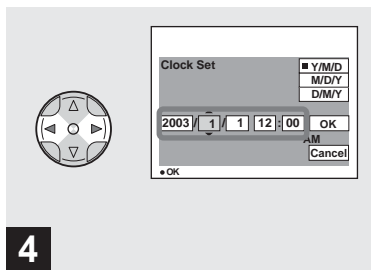

- 4**
- ➔ Select the year, month, day, hour or minute item you want to set with ◀/▶ on the control button.

The item to be set is indicated with ▲/▼.

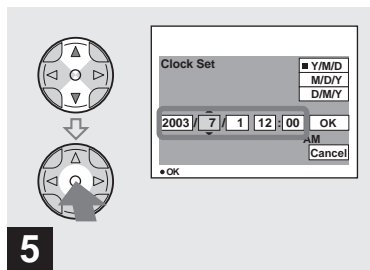

- 5**
- ➔ Set the numeric value with ▲/▼ on the control button, then press ● to enter it.

After entering the number, ▲/▼ moves to the next item. Repeat this step until all of the items are set.

- If you selected [D/M/Y] in step **3**, set the time on a 24-hour cycle.

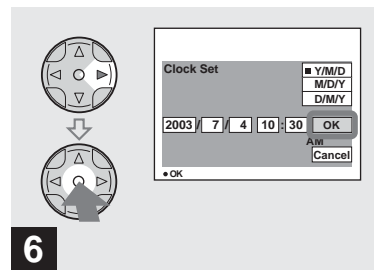

- 6**
- ➔ Select [OK] with ▶ on the control button, then press ●.

The date and time are entered and the clock starts to keep time.

- To cancel the date and time setting, select [Cancel] with ▲/▼/◀/▶ on the control button, then press ●.

Inserting and removing a disc

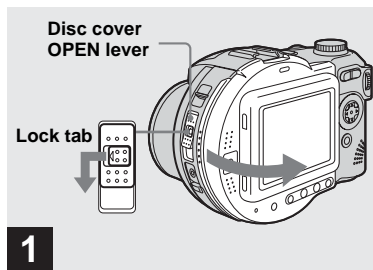

→ Open the disc cover.

While sliding the lock tab to the left, slide down the disc cover OPEN lever, and open the disc cover.

- You can use only 8 cm CD-R/CD-RW discs that have these marks.



- For details on disc, see page 120.

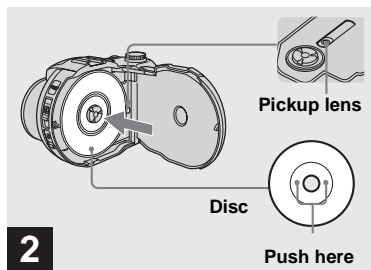

→ Place a disc in the disc tray.

Place the disc with the printed side up, and push down on the center of the disc until it clicks.

- Do not push with too force on the disc.
- Do not touch the pickup lens.

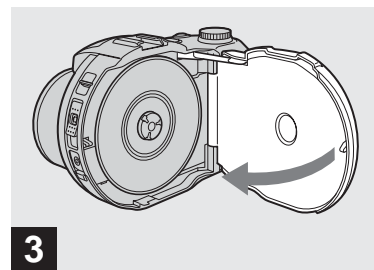

→ Close the disc cover.

Removing the disc

Open the disc cover. Check to make sure that the disc has completely stopped rotating, then remove the disc.

- **When the ACCESS lamp is flashing, it means that image data is being read or written. Never open the disc cover or turn off the power at this time, as the image data may be damaged or the disc may become unusable.**
- While the camera is writing data on a disc, the disc cover OPEN lever is locked.
- After you change the disc, “Repairing Data” may appear on the LCD screen and it may take about 10 minutes to prepare the disc for recording depending on the disc condition.

Initializing a disc

What is initialization?

Initialization is required to record images on a disc.

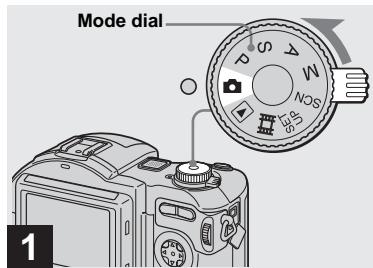

When you perform finalization (page 85) using your camera to view images through a CD-ROM drive, initialization is also automatically performed, and you can continue to record images. Images recorded before finalization remain on the disc.





➔ Insert a new disc and set the mode dial to , then turn on the power.



“Initialize Place on level surface” appears on the LCD screen.

To cancel initialization

Select [Cancel] with  on the control button, then press . After canceling the initialization, open and close the disc cover, then perform the procedure from step **1**.

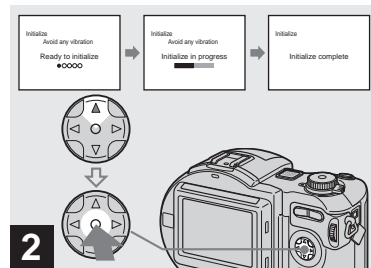
- You can also carry out this operation when the mode dial is set to P, S, A, M, SCN or .
- You can also perform initialization using  (Disc Tool 1) in the SET UP settings (page 117).



➔ Select [OK] with  on the control button, then press .

Initialization starts. Do not shake or strike the camera during initialization.

Setting the still image size

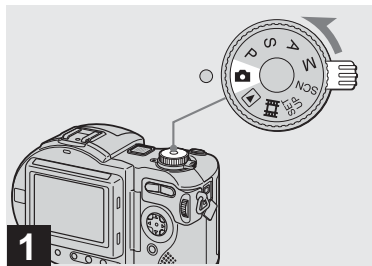

➔ Set the mode dial to  and turn on the power.

- You can also carry out this operation when the mode dial is set to P, S, A, M or SCN.

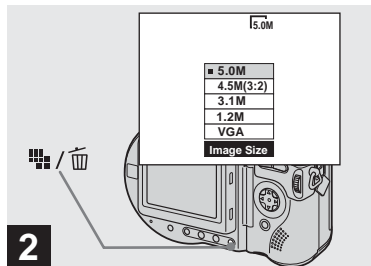

➔ Press  /  (Image Size).

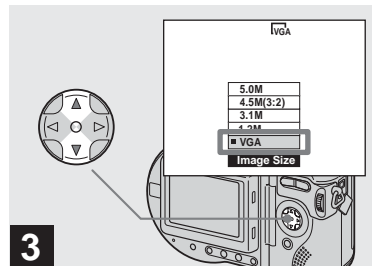

The Image Size setup appears.

- For details on the image size, see page 21.



➔ Select the desired image size with  on the control button.

The image size is set.

When the setting is complete, press  /  (Image Size) so that the Image Size setup disappears from the LCD screen.

- The image size selected here is maintained even when the power is turned off.

Image size and quality

You can choose image size (number of pixels) and image quality (compression ratio) based on the kind of images you want to shoot. The larger you make the image size and the higher you make the image quality, the better your image, but also the larger the amount of data needed to preserve your image. This means you can save fewer images in your disc.

Choose an image size and quality level appropriately for the kind of images you want to shoot.

You can resize the images later (Resize function, see page 77).

You can choose image size from among the five options in the following tables. The below image size is a minimum setting for examples. When you want to improve image quality, select the larger image size.

Image size		Examples
5.0M	2592×1944	Very fine prints
4.5M(3:2)	2592 (3:2)	3:2 prints ¹⁾
3.1M	2048×1536	Printing A4 size images
1.2M	1280×960	Printing postcard size images
VGA	640×480	Creating home pages

¹⁾ This option records images in a horizontal to vertical proportion of 3:2 to match the size of the print paper used.

The number of images that can be saved in a supplied CD-R²⁾

(Units: images)

Quality ³⁾ Image size	Fine	Standard
	5.0M	51
4.5M(3:2)	51	95
3.1M	81	145
1.2M	194	345
VGA	655	1285

²⁾ When [REC Mode] is set to [Normal]

For the number of images that can be saved in other modes, see page 110.

³⁾ For more information about the image quality mode, see page 43.

- When images recorded using earlier Sony models are played back on this camera, the display may differ from the actual image size.
- When the images are viewed on the LCD screen of the camera, they all look the same size.
- Number of shooting images can differ from these values according to shooting conditions.
- When the number of remaining shooting images is greater than 9999, the >9999 indicator appears on the LCD screen.

Basic still image shooting – Auto adjustment mode

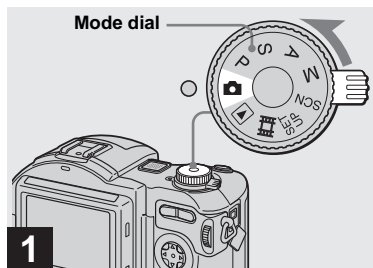

➔ **Set the mode dial to , and turn on the power.**

The name of the folder where the image will be recorded appears on the LCD screen for approximately five seconds.

- This camera can create new folders and select folders to be stored in the disc (page 43).

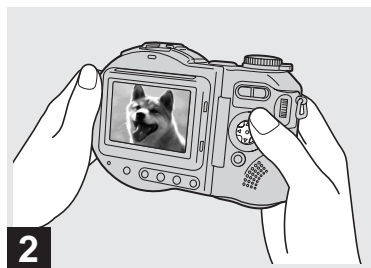

➔ **Hold the camera steadily with both hands and position the subject in the center of the focus frame.**

The lens portion moves when you turn on the power.

Do not cover the lens or flash with your fingers.

- The minimum focal distance to the subject is 50 cm (19 3/4 inches). To shoot even closer subjects, use macro recording mode (page 26).



➔ **Press and hold the shutter button halfway down.**

The beep sounds. When the AE/AF lock indicator changes from flashing to steadily lit, the camera is ready for shooting. (The LCD screen may be frozen for a split second depending on the subject.) The flash automatically pops up and strobes when the surroundings are dark.

- If you release the shutter button, the recording will be canceled.
- When the camera does not beep, the AF adjustment is not complete. You can continue to shoot, but the AF is not set properly (except in Continuous AF, see page 49).
- The frame appearing on the LCD screen shows the focus adjustment range. (For more details on the AF range finder frame, see page 47.)

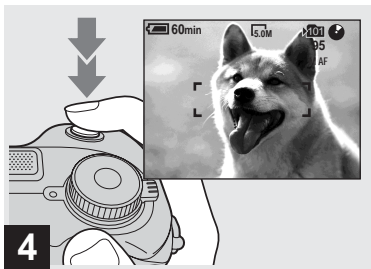

➔ Press the shutter button fully down.

The shutter sounds. The image will be recorded in the disc. When ACCESS lamp (page 10) goes out, you can shoot the next image.

- When operating the camera using a battery pack, if you do not operate the camera for about three minutes during recording, the camera turns off automatically to prevent wearing down the battery (page 15).
- While the image is being recorded on the disc, the ACCESS lamp flashes. Do not shake or strike the camera while this lamp is flashing. Also do not turn off the power, remove the battery pack, or open the disc cover at this time, as the data may be damaged or the disc may become unusable.

Mode dial for still image shooting

When shooting still images with your camera, you can choose from the following shooting methods.

(Auto adjustment mode)

The focus, exposure and white balance are automatically adjusted to allow easy shooting. The image quality is set to [Fine] (page 43).

P (Program auto shooting)

You can set the desired shooting functions using menus (pages 41 and 112). In addition, you can change the combination of the F value and the shutter speed (Program Shift, see page 45).

S (Shutter speed priority)

You can set the desired shooting functions using menus (pages 41 and 112). In addition, you can select the shutter speed (page 46).

A (Aperture priority)

You can set the desired shooting functions using menus (pages 41 and 112). In addition, you can select the aperture value (page 47).

M (Manual)

You can set the desired shooting functions using menus (pages 41 and 112). In addition, you can manually adjust the shutter speed and the aperture value (page 47).

SCN (Scene selection)

You can select from the following modes to shoot according to the scene conditions (page 64).

-  (Twilight mode)
-  (Twilight portrait mode)
-  (Landscape mode)
-  (Portrait mode)
-  (Snow mode)
-  (Beach mode)

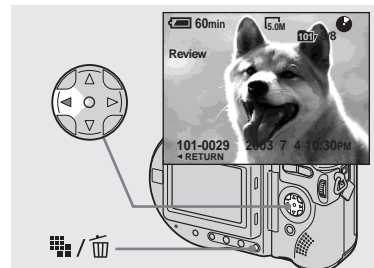

Checking the last image you shot — Quick Review



➔ Press ◀ (Ⓢ) on the control button.

To return to the normal shooting mode, press lightly on the shutter button or press ◀ (Ⓢ) again.

To delete the image displayed on the screen

- 1 Press  /  (Delete).
- 2 Select [Delete] with ▲ on the control button, then press ●. The image is deleted.

Auto Focus

When you try to shoot a subject that is difficult to focus on, the AE/AF lock indicator changes to flashing slowly. The Auto Focus function may have difficulty working under the following conditions. In such cases, release the shutter button, then recompose the shot and focus again.

- The subject is distant from the camera and dark.
- The contrast between the subject and its background is poor.
- The subject is seen through glass, such as a window.
- A fast-moving subject.
- The subject reflects or has a lustrous finish, such as a mirror or a luminous body.
- A flashing subject.
- A backlit subject.

There are two Auto Focus functions: “AF range finder frame” which sets the focus position according to the subject position and size, and “AF mode” which sets the focus operation according to the AF response and the battery consumption. See page 47 for details.

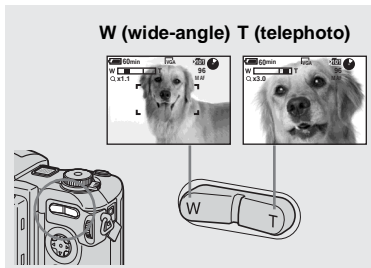

➔ **Press the zoom button to choose the desired zoom position for shooting.**

Minimum focal distance to the subject

Approx. 50 cm (19 3/4 inches) from the lens surface

- The lens portion moves during zoom operation. Do not touch the lens portion while it is operating.
- The zoom magnification cannot be changed while shooting movies (page 80).

Smart zoom

Digital processing lets you zoom in the image without deterioration.

When the zoom exceeds 3×, enlargement is carried out using the smart zoom. When the smart zoom is not needed, set [Smart Zoom] to [Off] in the SET UP settings (page 116). When you press the zoom button, the zoom scaling indicator appears on the LCD screen.

Zoom scaling indicator

The T side of this line shows the extent of smart zoom

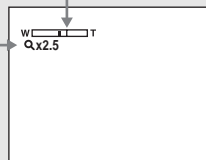

The maximum zoom scale depends on the image size.

[3.1M]: 3.8×

[1.2M]: 6.1×

[VGA]: 12×

When the image size is [5.0M] or [4.5M(3:2)], the smart zoom does not work.

- When using the smart zoom, the image on the LCD screen may look rough. However, this phenomenon has no effect on the recorded image.
- AF range finder frame is not shown when using the smart zoom. The AF range finder indicator flashes and the centrally-located subject has priority to focus on.



The macro recording mode is used when zooming up a small subject, such as flowers or insects. You can shoot close-ups of subjects up to the distances specified below.

When the zoom is set all the way to the W side:

Approx. 4 cm (1 5/8 inches) from the lens surface

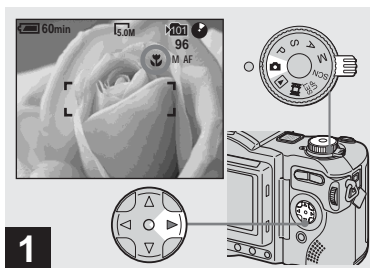

When the zoom is set all the way to the T side:

Approx. 20 cm (7 7/8 inches) from the lens surface





- 1** → Set the mode dial to , and press  on the control button.

The  (macro) indicator appears on the screen.

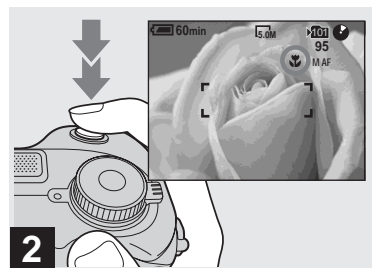
- If the menu is currently displayed, press MENU first so that the menu disappears.
- You can also carry out this operation when the mode dial is set to P, S, A, M, SCN (other than ) (Twilight mode) or ) (Landscape mode), see page 64) or .





- 2** → Center the subject in the frame, and press the shutter button fully down.

To return to normal recording mode
Press  on the control button again. The  indicator disappears.

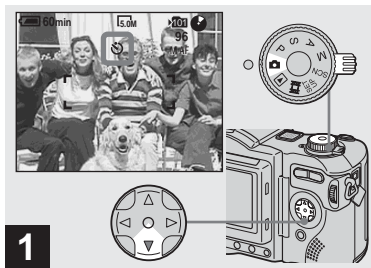
Using the self-timer



- ➔ Turn the mode dial to , and press  on the control button.

The  (self-timer) indicator appears on the LCD screen.

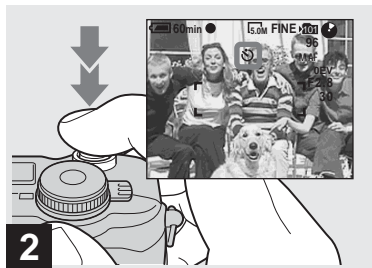

- If the menu is currently displayed, press MENU first so that the menu disappears.
- You can also carry out this operation when the mode dial is set to P, S, A, M, SCN or .



- ➔ Center the subject in the frame, and press the shutter button fully down.

The self-timer lamp (page 9) flashes and a beep sounds after you press the shutter button until the shutter operates (approximately 10 seconds).



To cancel the self-timer in the middle of the operation

Press  on the control button again. The  indicator disappears from the LCD screen.

- If you press the shutter button while standing in front of the camera, the focus and the exposure may not be correctly set.

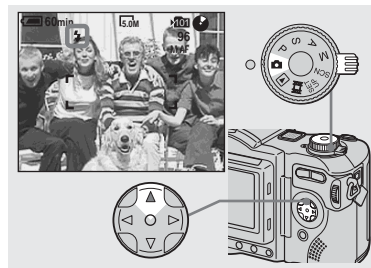
Selecting a flash mode



- ➔ Set the mode dial to , and press  on the control button repeatedly to select a flash mode.

Each time you press , the indicator changes as follows.

No indicator (Auto): The flash automatically pops up and strobos when the surroundings are dark.



⚡ (Forced flash): The flash strobos regardless of the surrounding brightness.



⚡SL (Slow synchro): The flash strobos regardless of the surrounding brightness. The shutter speed is slow in a dark place, so you can clearly shoot the background that is out of flash light.



⊘ (No flash): The flash does not strobe.

- If the menu is currently displayed, press MENU first so that the menu disappears.
- You can also carry out this operation when the mode dial is set to P, S, A, M, SCN (Portrait mode) or  (Clip Motion).
- The recommended shooting distance using the flash is approximately 0.5 m to 5.0 m (19 3/4 inches to 196 7/8 inches) (when [ISO] is set to [Auto]).

- You can change the brightness of the flash with [Flash Level] in the menu settings (page 113). (You cannot change the brightness of the flash while the mode dial is set to .)
- When using the ⚡SL (Slow synchro) or ⊘ (No flash) mode, the shutter speed becomes slower in dark places, so using a tripod is recommended.
- While charging the flash, the ⚡/CHG lamp flashes. After the charging is complete, the lamp goes out.
- When you press the shutter button halfway down while the flash is strobing, the ⚡/CHG lamp turns on.
- You can mount an external flash on this camera (page 67).
- Attaching a conversion lens (not supplied) may block the light from the built-in flash or cause the lens shadow to appear.
- This setting is maintained even when the power is turned off.

To reduce the red-eye phenomenon when shooting live subjects

Set [Red Eye Reduction] to [On] in the SET UP settings (page 116).  indicator appears on the LCD screen, and the flash pre-strobes before shooting to reduce the red-eye phenomenon.



- Red-eye reduction may not produce the desired effects depending on individual differences, the distance to the subject, if the subject does not see the pre-strobe, or other conditions.



Recording images with the hologram AF

The hologram AF is fill light to focus more easily on a subject in dark surroundings.

When not using this function, set [Hologram AF] to [Off] in the SET UP settings (page 116).

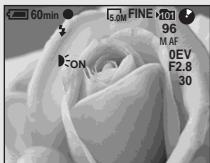
AF-ON appears on the screen and the hologram AF emits red light when the shutter button is pressed halfway until the focus is locked.



- If hologram AF light does not reach the subject sufficiently or the subject has weak contrast, focus will not be achieved. (An approximate distance of 0.5 m to 4.0 m (19 3/4 inches to 13 feet 1 3/8 inches) is recommended.)
- Focus is achieved as long as hologram AF light reaches the subject, even if the light is slightly off the center of the subject.
- When the focus preset distance is set (page 50), the hologram AF does not function.
- When [Conversion Lens] is set to [On] in the SET UP settings (page 117), the hologram AF does not function.
- If the hologram AF emitter is dirty, the hologram AF light may be dimmed and focus may not be achieved. In this case, wipe the hologram AF emitter with a dry cloth.
- The hologram AF emitter emits very bright light. Although there are no problems with safety, directly looking into the hologram AF emitter at close range is not recommended.
- Do not block the hologram AF emitter during recording.
- The AF range finder frame is not displayed. AF range finder frame indicator flashes and the centrally-located subject has priority to focus on.
- The hologram AF does not function when SCN is set to  (Twilight mode) or  (Landscape mode).

About Hologram AF

“Hologram AF (Auto-Focus)” is an AF fill light system that applies laser holograms to enable you to shoot still images in dark places. The Hologram AF system uses gentler radiation than conventional high-brightness LEDs or lamps, thus satisfying Laser Class 1* specifications and maintaining higher safety for human eyes.

* Hologram AF satisfies Class 1 (time base 30 000 seconds), specified in JIS (Japan), IEC (EU), and FDA (US) industry standards. Complying with these standards identifies the laser product as safe, under the condition that a human can look at the laser light either directly or focused through a lens for 30 000 seconds.

Indicators on the screen during shooting

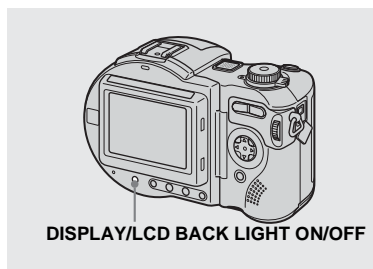

Each time you press DISPLAY/LCD BACK LIGHT ON/OFF, the display changes in the following order.

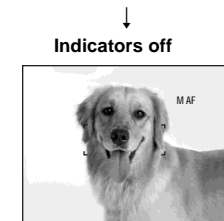
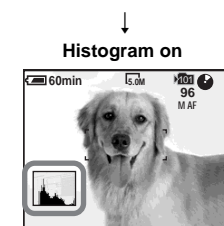

Backlight off

- For a detailed description of the indicators, see page 125.
- For a detailed description of the histogram, see page 52.
- The setting selected here is maintained even when the power is turned off.

Inserting the date and time on a still image

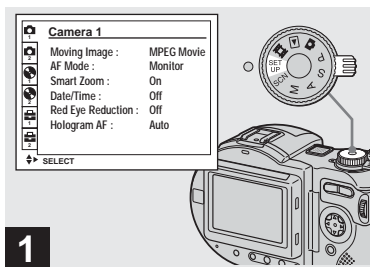

1

➔ Set the mode dial to SET UP.

The SET UP screen appears.

- When images are shot with the date and time superimposed, the date and time cannot be removed later.
- The date and time do not appear on the LCD screen during shooting, instead, “DATE” appears in the upper left corner of the LCD screen. The actual date and time appear in red during playback only.

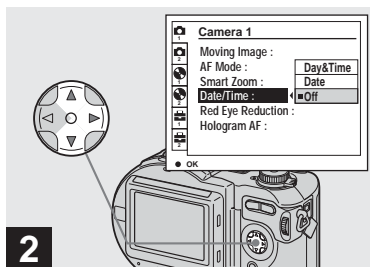

2

➔ Select (Camera 1) with ▲ on the control button, then press ►.

Select [Date/Time] with ▲/▼, then press ►.

- If you select [Date], the date is superimposed onto the image in the order selected in “Setting the date and time” (page 16).

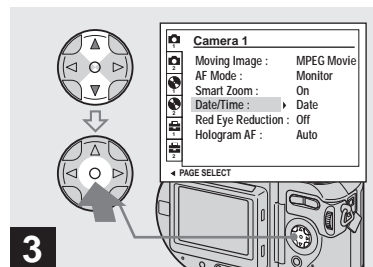

3

➔ Select the date and time setting with ▲/▼ on the control button, then press ●.

Day & Time: Superimposes the date, hour, and minute onto the image.

Date: Superimposes the year, month and day onto the image.

Off: Does not superimpose the date and time onto the image.

After the setting has been completed, set the mode dial to , and shoot the image.

- You can also superimpose the date and time with the mode dial set to P, S, A, M or SCN.
- This setting is maintained even when the power is turned off.

Viewing images on the LCD screen of your camera

Single (single-image) screen



Index (nine-image) screen



Index (triple-image) screen

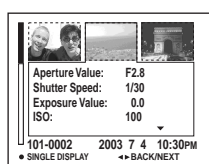

You can view images shot with your camera almost immediately on the LCD screen.

You can select the following three methods for viewing images.

Single (single-image) screen

You can view one image at a time, displayed over the entire screen.

Index (nine-image) screen

Nine images are displayed simultaneously in separate panels on the screen.

Index (triple-image) screen

Three images are displayed simultaneously in separate panels on the screen. Various image information items are also displayed.

- You can switch the displayed image to the previous image or the next image by rotating the jog dial (page 42).

Viewing single images

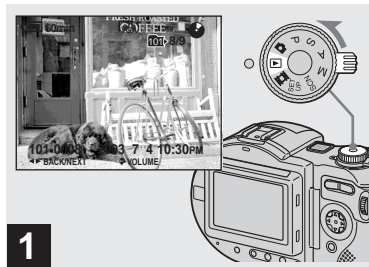

- ➔ **Set the mode dial to , and turn on the power.**

The last image in the selected recording folder (page 43) appears on the screen.

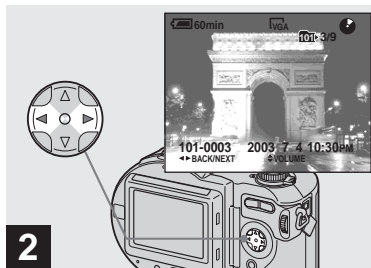

➔ Select the desired still image with ◀/▶ on the control button.

◀ : To display the preceding image
▶ : To display the next image

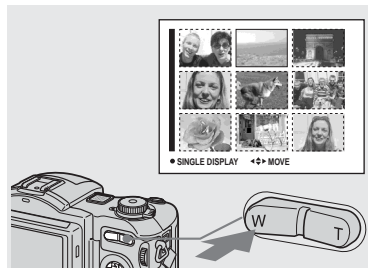

➔ Press the zoom W (index) button once.

The display switches to the **Index (nine-image) screen**.

To display the next (previous) index screen

Press ▲/▼/◀/▶ on the control button to move the yellow frame up/down/left/right.

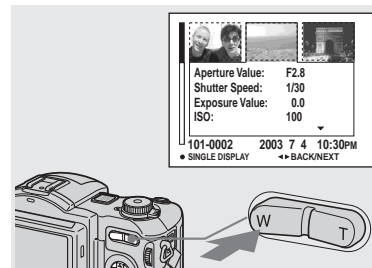

➔ Press the zoom W (index) button once more.

The display switches to the **Index (triple-image) screen**.

Press ▲/▼ on the control button to display the remaining image information.

To display the next (previous) index screen

Press ◀/▶ on the control button.

To return to the single-image screen

Press the zoom T repeatedly, or press ● on the control button.

Viewing images on a TV screen

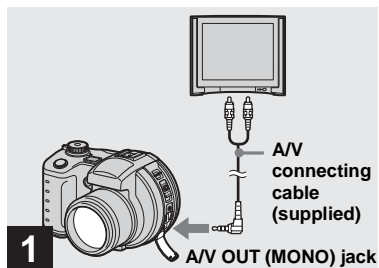

- ➔ **Connect the supplied A/V connecting cable to the A/V OUT (MONO) jack of the camera and the audio/video input jacks of the TV.**

If your TV has stereo input jacks, connect the audio plug (black) of the A/V connecting cable to the Lch jack.

- Turn off both your camera and the TV before connecting the camera and the TV with the A/V connecting cable.
- We recommend using the AC Adaptor (supplied) to prevent the power from turning off partway.

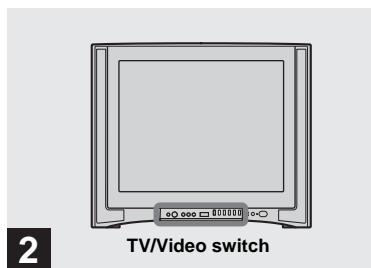

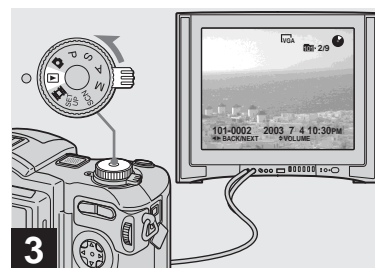

- ➔ **Turn on the TV and set the TV/Video switch to “Video”.**

- The name and location of this switch may differ depending on your TV. For details, see the operating instructions supplied with the TV.



- ➔ **Set the mode dial to , and turn on the camera.**

Press   on the control button to select the desired image.

- When using your camera abroad, it may be necessary to switch the video output signal to match that of your TV system (page 118).

Viewing images on a TV screen

If you want to view images on a TV screen, you need a TV with a video input jack and the A/V connecting cable (supplied).

The color system of the TV must match that of your digital still camera. Check the following lists:

NTSC system

Bahama Islands, Bolivia, Canada, Central America, Chile, Colombia, Ecuador, Jamaica, Japan, Korea, Mexico, Peru, Surinam, Taiwan, the Philippines, the U.S.A., Venezuela, etc.

PAL system

Australia, Austria, Belgium, China, Czech Republic, Denmark, Finland, Germany, Holland, Hong Kong, Italy, Kuwait, Malaysia, New Zealand, Norway, Portugal, Singapore, Slovak Republic, Spain, Sweden, Switzerland, Thailand, United Kingdom, etc.

PAL-M system

Brazil

PAL-N system



Argentina, Paraguay, Uruguay

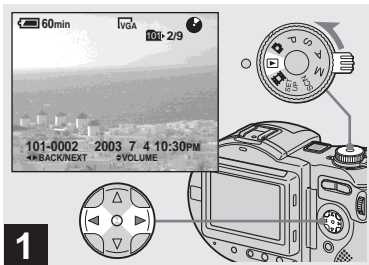

SECAM system

Bulgaria, France, Guiana, Hungary, Iran, Iraq, Monaco, Poland, Russia, Ukraine, etc.

Deleting images



- 1** → Set the mode dial to , and turn on the camera. Press  on the control button to select the image you want to delete.

- When using a CD-R, the disc remaining space does not increase even if you delete images.
- When using a CD-RW, the disc remaining space increases only if you delete the last image you shot while  is indicated on the LCD screen. If you modify an image, or open and close the disc cover,  disappears.
- If the disc remaining space is not sufficient, you may not be able to delete the image.
- It may take some time to delete the images.

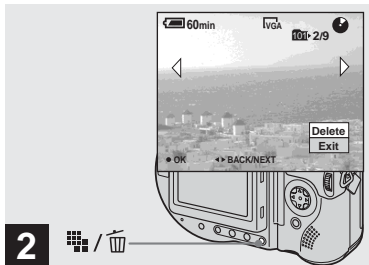



- 2** → Press  /  (Delete).

The image has not yet been deleted at this point.

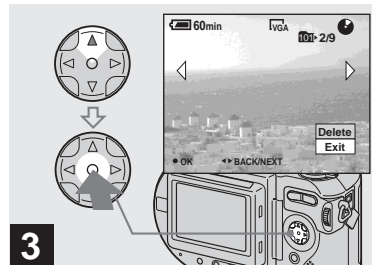



- You cannot delete the protected image (page 75).





- 3** → Select [Delete] with  on the control button, then press .

When the message “Disc access” disappears, the image has been deleted.

To continue and delete other images

Display the image to be deleted with   on the control button. Then, select [Delete] with  and press .

To cancel deleting

Select [Exit] with  on the control button, then press .

Deleting images in index (nine-image) mode

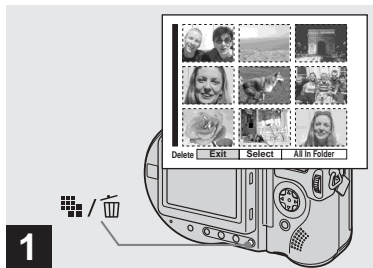

→ While an index (nine-image) screen (page 33) is displayed, press / (Delete).

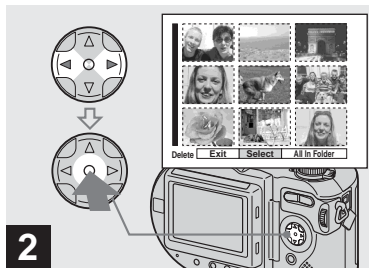

→ Select [Select] with / on the control button, then press .

To delete all the images in the folder Select [All In Folder] with on the control button, then press . Select [OK], then press . All of the unprotected images in the folder are deleted. To cancel deleting, select [Cancel], then press .

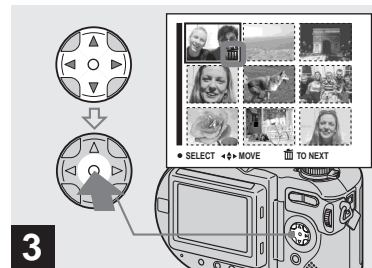





→ Select an image you want to delete with / / / on the control button, then press .

The green indicator appears on the selected image. At this point, the image has not yet been deleted. Repeat this step for all of the images you want to delete.

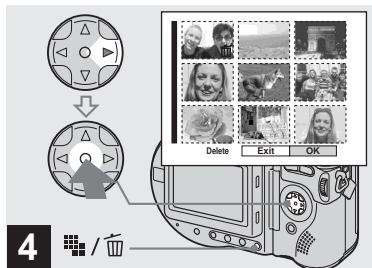
- To cancel a selection, press again so that the indicator disappears.



Deleting images in index (triple-image) mode





- Press  /  (Delete) and select [OK] with  on the control button, then press .

When the message “Disc access” disappears, the images have been deleted.

To cancel deleting

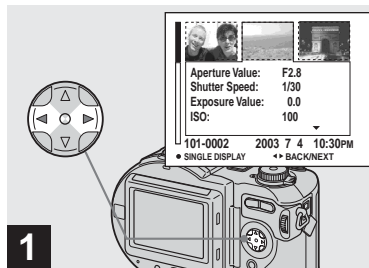
Select [Exit] with  on the control button, then press .



- While an index (triple-image) screen (page 33) is displayed, set the image you want to delete to the center with  /  on the control button.

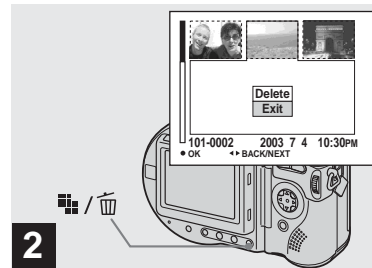

- Press  /  (Delete).

The image has not yet been deleted at this point.

Formatting a CD-RW

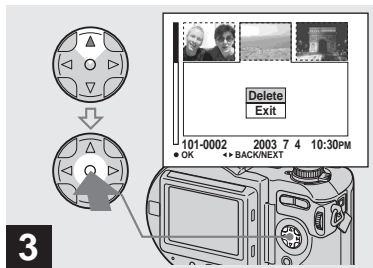

➔ Select [Delete] with ▲ on the control button, then press ●.

When the message “Disc access” disappears, the image has been deleted.

To cancel deleting

Select [Exit] with ▼ on the control button, then press ●.

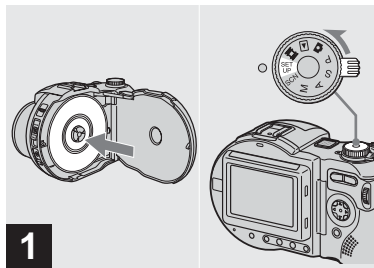

➔ Place the CD-RW you want to format in the disc tray.
Set the mode dial to SET UP, and turn on the camera.

- A CD-R cannot be formatted.
- Formatting is performed to delete all the images on the CD-RW or to use a CD-RW formatted with other equipment than this camera.
- **When you format a CD-RW, all data stored on the disc including protected images will be deleted. The CD-RW is also automatically initialized after formatting.**

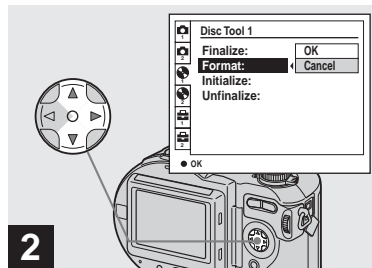

➔ Select  (Disc Tool 1) with ▲/▼ on the control button, then press ►. Select [Format] with ▲/▼, then press ►.

- We recommend using the AC Adaptor to prevent the power from turning off partway through the formatting.

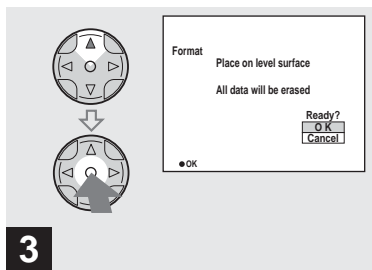

➔ **Select [OK] with ▲ on the control button, then press ●.**

“Format Place on level surface” appears on the LCD screen.

To cancel formatting

Select [Cancel] with ▼ on the control button, then press ●.

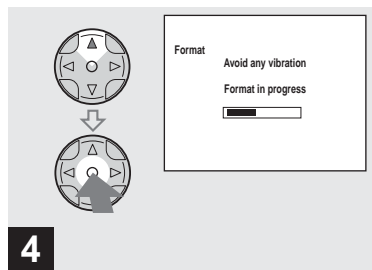

➔ **Select [OK] with ▲, then press ●.**

When the message “Format in progress” disappears, formatting has been completed.

- It may take some time to format a CD-RW.
- A CD-RW can be formatted about 300 times.
- A CD-RW formatted using other equipment than this camera cannot be used with this camera. Format the disc again with this camera.

How to setup and operate your camera

The usage of the menus and SET UP screen items that are most frequently used for “Advanced operations” is described below.

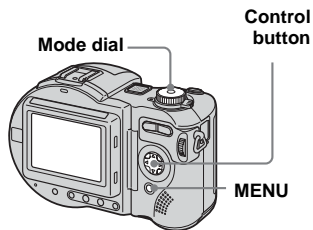

Changing the menu settings

1 Press MENU.

The menu appears.

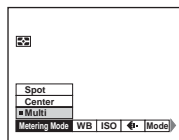

2 Press ◀/▶ on the control button to select the item you want to set.

The selected item turns yellow.

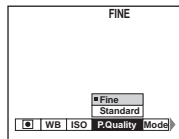

3 Press ▲/▼ on the control button to select the desired setting.

The frame of the selected setting turns yellow, and the setting is entered.

To turn off the menu display

Press MENU.

Changing the items in the SET UP screen

1 Set the mode dial to SET UP.

The SET UP screen appears.

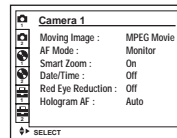

2 Press ▲/▼/◀/▶ on the control button to select the item you want to set.

The frame of the selected item turns yellow.

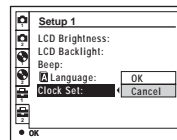

3 Press ● on the control button to enter the setting.

To turn off the SET UP screen display

Set the mode dial to anything other than SET UP.

How to use the jog dial

The jog dial is used to change the setting values when shooting with the manual adjustment modes (shutter speed priority mode, aperture priority mode, manual exposure mode), EV adjustment, focusing manually or choosing AF range finder frame.

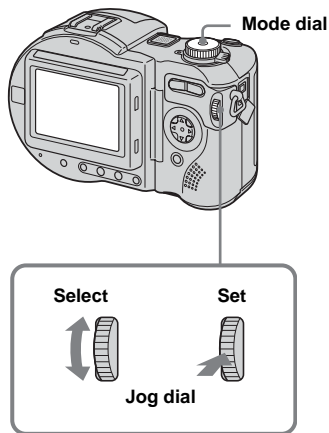

To select the item

1 Turn the jog dial to select the item you want to set.

Move the yellow indication ◀ to select the item.

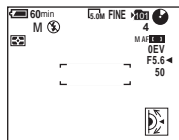

2 Press the jog dial.

The value turns yellow.

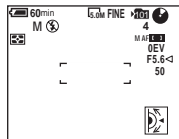

3 To set other items, press the jog dial and then perform the following operations.

- Items that cannot be selected are displayed as gray.

To select the value

You can select values that are displayed in yellow.

Turn the jog dial to select the value you want to set

The displayed value is set.

Deciding the still image quality

Mode dial: P/S/A/M/SCN

You can select the still image quality from [Fine] or [Standard].

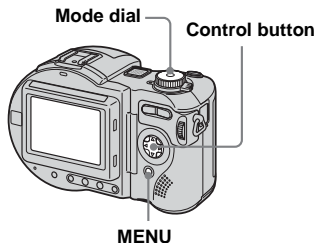



1 Set the mode dial to P, S, A, M or SCN.

2 Press MENU.

The menu appears.

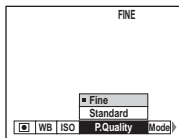
3 Select ◀▶ (P. Quality) with ◀/▶, then select the desired image quality with ▲/▼.



- This setting is maintained even when the power is turned off.
- You can also carry out this operation when the mode dial is set to  (Multi Burst) (page 60).

Creating or selecting a folder

Mode dial: SET UP

Your camera can create multiple folders within a disc. You can select the folder used to store images.

When not creating a new folder, "101MSDCF" folder is selected as the recording folder.

You can create folders up to "999MSDCF."

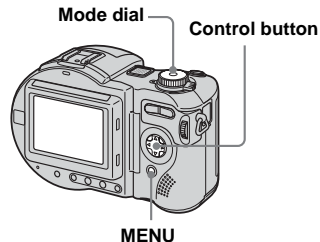

- Up to 4000 images can be stored in one folder. When the folder capacity is exceeded, a new folder is automatically created.

Creating a new folder

- 1 Set the mode dial to SET UP.
- 2 Select  (Disc Tool 2) with **▲/▼**, [Create REC. Folder] with **▶/▲/▼**, and [OK] with **▶/▲**, then press **●**.

The following screen appears.



- 3 Select [OK] with **▲**, then press **●**.

A new folder is created with a number one higher than the largest number in the disc, and the folder becomes the recording folder.

To cancel folder creation

Select [Cancel] in step **2** or **3**.

- Once you create a new folder, you cannot delete the new folder with the camera.
- Images are recorded in the newly created folder until a different folder is created or selected.

Changing the recording folder

- 1 Set the mode dial to SET UP.
- 2 Select  (Disc Tool 2) with **▲/▼**, [Change REC. Folder] with **▶/▲/▼**, and [OK] with **▶/▲**, then press **●**.

The recording folder selection screen appears.

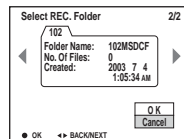

- 3 Select the desired folder with **◀/▶**, and [OK] with **▲**, then press **●**.

To cancel changing the recording folder

Select [Cancel] in step **2** or **3**.

- You cannot select the “100MSDCF” folder as a recording folder.
- The image is stored in the newly selected folder. You cannot move images to a different folder with this camera.

Shooting with Program Shift

— Program Shift

Mode dial: P

Program Shift lets you quickly change the F value (aperture value) and shutter speed combination while keeping the brightness fixed.

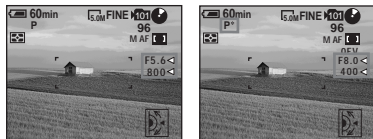
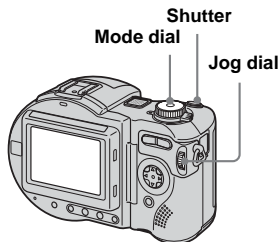

1 Set the mode dial to P.

2 Shift the F value and shutter speed combination.

Select the F value and shutter speed combination with the jog dial (page 42). p* is indicated.

- You cannot shift the F value and shutter speed combination when the shutter button is pressed halfway down.
- When the brightness changes, the F value and shutter speed also change.

Shooting with the manual adjustments

Mode dial: S/A/M

You can manually adjust the shutter speed and aperture values according to the purpose of shooting.

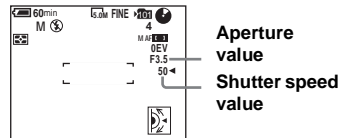

Mode dial	Description
S	Shutter speed priority mode. Other settings are automatically adjusted to attain correct exposure according to the brightness of the subject.
A	Aperture priority mode. Other settings are automatically adjusted to attain correct exposure according to the brightness of the subject.
M	Mode for manually adjusting both the shutter speed and aperture values to achieve the desired shooting condition.

- You cannot make manual adjustments when shooting movies.
- If the proper exposure is not obtained after making the settings, the setting value indicators on the screen may flash when the shutter button is pressed halfway down. You can shoot in this condition, but we recommend that you adjust the flashing values again.
- The auto flash function does not operate.
- You can adjust an exposure value when the mode dial is set to S or A (page 51).

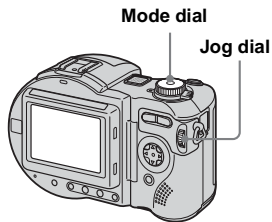

Shutter speed priority mode

This function lets you shoot a fast-moving subject with its motion frozen, or the flow motion of a moving subject.

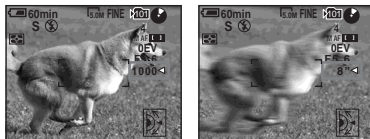

1/1000 s (shortest) 8 s (longest)

1 Set the mode dial to S.

2 Select a shutter speed value.

Select a shutter speed with the jog dial (page 42). The shutter speed can be selected from 1/1000 to 8 seconds. If you select a shutter speed of 1/6 second or slower, NR slow shutter function is automatically activated.

- Shutter speeds of one second or longer are indicated with ["] after the value, such as 1".

NR slow shutter

The NR slow shutter function removes noise from recorded images, providing clear images. When using a shutter speed of 1/6 second or slower, the NR slow shutter function activates automatically and "NR" appears before the shutter speed indication.



Press the shutter button fully down.

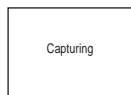

Then the screen turns black.

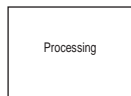

Finally, when "Processing" disappears, the image has been recorded.

- To eliminate the effects of vibration, use of a tripod is recommended.
- When a slow shutter speed is set, processing may take some time.

Aperture priority mode

This function lets you change the focus depth to bring both the subject and background into focus or to shoot a subject with a fuzzy background.



Aperture value F2
(minimum)



Aperture value F8
(maximum)

1 Set the mode dial to A.

2 Select an aperture value.

Select an aperture value with the jog dial (page 42). The aperture value can be selected from F2 to F8.

- The range of values that can be selected varies, depending on the zoom position.
- The shutter speed is automatically adjusted from 1/1000 to 8 seconds.

Manual exposure mode

You can manually adjust the shutter speed and aperture values to achieve the desired shooting condition according to your purpose.

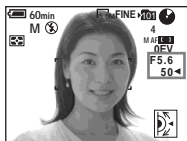

The difference between the set value and the appropriate exposure determined by the camera is displayed on the screen as the EV value (page 51). 0EV indicates that the most suitable value has been set by the camera.

1 Set the mode dial to M.

2 Select the shutter speed value.

Select the shutter speed value with the jog dial (page 42).

3 Select the aperture value.

Select the aperture value with the jog dial (page 42).

Choosing an auto focus method

You can set the AF range finder frame and the AF mode.

AF range finder frame

The AF range finder frame selects the focus position according to the subject position and size.

AF Mode

The AF mode sets the focus operation according to the AF response and the battery consumption.

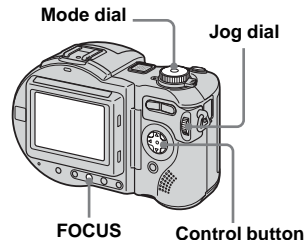

Choosing a focus range finder frame

— AF range finder

Mode dial: P/S/A/M/SCN/

Multipoint AF

The camera calculates the distance in three places to the left and right and in the center of the image, letting you shoot using the auto focus function without worrying about the image composition. This is useful when it is difficult to focus on the subject because it is not in the center of the frame. You can check the position where the focus was adjusted using the green frame. The Multipoint AF is the factory setting.

Selected frame priority AF

You can select from five different AF range finder frames (Center, Left, Right, Top or Bottom). This is useful when focusing on a subject near the selected frame. Use together with the AF lock function lets you shoot in the desired image composition.

Spot AF

This is useful when focusing on an extremely small subject or a narrow area. Use together with the AF lock function lets you shoot in the desired image composition. Take care to hold the camera steady so that the subject does not deviate from the range finder frame.

1 Set the mode dial to P, S, A, M, SCN or .

2 Press FOCUS to switch to AF range finder frame select.

Each time you press FOCUS, the setting changes in the following order.
AF range finder frame select



Focus preset

3 Select the desired AF range.

Select the AF range with the jog dial (page 42).

You can select the AF range from Multipoint AF, Center, Left, Right, Bottom, Top and Spot AF.

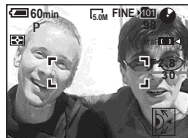

AF range finder frame

The focus is adjusted automatically. When you press and hold the shutter button halfway down and the focus is adjusted, the color of the AF range finder frame changes from white to green.

- When you are shooting movies (MPEG Movie) and you choose Multipoint AF, the distance to the center of the screen is estimated as an average, so the AF works even with a certain amount of vibration. Selected frame priority AF and Spot AF automatically focus only on selected frame, so these are convenient when you want to focus only on what you aim at.
- When you use the smart zoom or Hologram AF, priority AF movement is given to subjects in or near the center of the frame. In this case, AF range finder frame indicator flashes and the AF range finder frame is not displayed.

Choosing a focus operation

— AF Mode

Mode dial: SET UP

You can select from the following three focus modes for your camera.

Single AF (S AF)

This mode allows accurate focusing over a wide range from near to distant subjects, and is useful for shooting stationary subjects. The focus is not adjusted before the shutter button is pressed and held halfway down. When the shutter button is pressed and held halfway down and AF lock is complete, the focus is locked.

Monitoring AF (M AF)

This shortens the time needed for focusing. The camera adjusts the focus before the shutter button is pressed and held halfway down, letting you compose images with the focus already adjusted. When the shutter button is pressed and held halfway down and AF lock is complete, the focus is locked. The factory setting is Monitoring AF.

- Battery consumption may be faster than in Single AF mode.

Continuous AF (C AF)

The camera adjusts the focus before the shutter button is pressed and held halfway down, and then continues to adjust the focus even after AF lock is completed. This allows shooting of moving subjects with continued focus.

- The focus is not adjusted after the lock is completed in the following cases, and the C AF indicator flashes. The camera operates in Monitoring AF mode.
 - When shooting in the dark place
 - When shooting with a slow shutter speed
- The AF range finder frame is locked to the center.
- Focus adjustment may not be able to keep up when shooting fast moving subjects.
- There is no lock sound when the focus is adjusted.
- When recording with the self timer, the focus is locked when you press the shutter button all the way down.
- Battery consumption may be faster than in any other AF mode.

1 Set the mode dial to SET UP.

2 Select  (Camera 1) with ▲, [AF Mode] with ►/▲/▼.

3 Select the desired mode with ►/▲/▼, then press ●.

- When shooting in Macro mode, the AF speed drops in order to focus accurately on close subjects. For quicker shooting, using a different mode than Macro mode is recommended.

Shooting techniques

When shooting with the subject at the edge of the frame, the camera may focus on the center instead of on the subject at the edge of the frame. In a case like this, use AF lock to focus on the subject, and then recompose the picture and shoot (except in Continuous AF mode).

Compose the shot so that the subject is centered in the AF range finder, and press the shutter button halfway down.

When the AE/AF lock indicator stops flashing and remains on, return to the fully composed shot, and press the shutter button fully down.

AE/AF lock indicator



AF range
finder frame



- When you are using AF lock, you can capture an image with the correct focus even if the subject is at the edge of the frame.

- You can carry out the AF lock adjustment process before you press the shutter button fully down.

Setting the distance to the subject

— Focus preset

Mode dial: P/S/A/M/SCN/

When shooting an image using a previously set distance to the subject, or when shooting a subject through a net or through window glass, it is difficult to get the proper focus in auto focus mode. In these cases, use of the Focus preset is convenient.

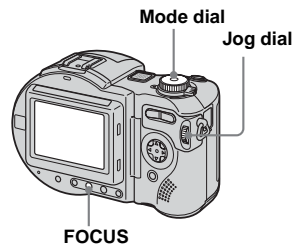

1 Set the mode dial to P, S, A, M, SCN, or .

2 Press FOCUS to switch to focus preset.

Each time you press FOCUS, the setting changes in the following order.

Focus preset



AF range finder frame select

The focus is fixed and the  (manual focus) indicator appears.

3 Turn the jog dial to select the desired focus setting.

You can select from the following

distance settings: (Units: m)

0.1, 0.2, 0.3, 0.5, 0.8, 1.0, 1.5, 2.0, 3.0, 5.0, 7.0, 10, 15, and ∞ (infinity)

To reactivate auto focusing

Press FOCUS again so that the focus setting information disappears.

- Focus setting information is approximate, and should be used as a reference.
- If you point the lens up or down, the error will increase.
- When you select 0.1 m (4 inches) with the zoom set to the T side, you may not get a clear focus. In such cases, the focus setting information flashes. Press the zoom W button until the indicator stops flashing.
- The focus preset does not work properly when attaching a conversion lens (not supplied).

Adjusting the exposure

— EV adjustment

Mode dial: P/S/A/SCN 

This lets you adjust the exposure value which is set by automatic adjustment. You can select values ranging from +2.0EV to -2.0EV in steps of 1/3EV.

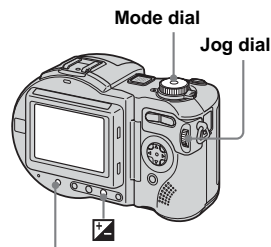

DISPLAY/LCD BACK LIGHT ON/OFF

1 Set the mode dial to P, S, A, SCN or .

2 Press  (Exposure).

3 Select the desired exposure value with the jog dial.

Adjust the exposure value while checking the brightness of the background.

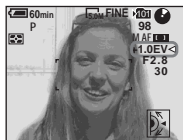

To reactivate auto exposure

Return the exposure adjustment value to 0EV.

- If a subject is being shot in extremely bright or dark conditions, or the flash is used, the exposure adjustment may not be effective.

Shooting techniques

Normally, the camera automatically adjusts the exposure. If the image is too dark or too bright as shown below, we recommend that you adjust the exposure manually. When shooting a back-lit subject or a subject against a white (e.g. snowy) background, adjust the exposure toward the + side. When shooting a black, subject that fills the screen, adjust the exposure toward the – side.



Underexposed
→ Adjust toward +



Appropriate exposure



Overexposed
→ Adjust toward –

Displaying a histogram

A histogram is a graph showing the brightness of an image. The horizontal axis shows the brightness, and the vertical axis shows the number of pixels. The graph display indicates a dark image when skewed to the left side, and a bright image when skewed to the right side. The histogram is a useful reference for checking the exposure during recording and playback without being affected by the brightness of the LCD screen.





- 1** Set the mode dial to P, S, A, M or SCN.
- 2** Press DISPLAY/LCD BACK LIGHT ON/OFF to display the histogram.
- 3** Adjust the exposure based on the histogram.

Adjusting the exposure to the + side shifts the histogram to the right side.



Adjusting the exposure to the – side shifts the histogram to the left side.



- The histogram also appears when the mode dial is set to , but you cannot adjust the exposure.
- The histogram also appears when you press DISPLAY/LCD BACK LIGHT ON/OFF while playing back a single image (page 32) or during Quick Review (page 24).
- The histogram does not appear in the following cases:
 - When the menu is displayed
 - During Quick Review of an image recorded in Exposure Bracket mode
 - When using playback zoom
 - When playing back an image recorded with the mode dial set to 

-  appears in the following cases:
 - When recording in the smart zoom range
 - When the image size is [4.5M (3:2)]
 - When rotating a still image
- The histogram before recording represents the histogram of the image displayed on the screen at that time. A difference occurs in the histogram before and after you press the shutter button. When this happens, check the histogram while playing back a single-image or during Quick Review.

In particular a large difference may appear in the following cases:

- When the flash strobes
 - When [P. Effect] is set to [Solarize]
 - When the shutter speed is slow or high
- The histogram may not appear for images recorded using other cameras.

Selecting the metering mode

Mode dial: P/S/A/M/SCN/

This function enables you to select the metering mode to suit the shooting conditions and purpose.

Multi-pattern metering ()

The image is divided into multiple regions and metering is performed for each region. The camera judges the subject position and background brightness, and determines a well-balanced exposure.

The camera is set to multi-pattern metering as the factory setting.

Center-weighted metering ()

Metering is performed with priority given to the center of the image. The camera determines the exposure based on the brightness of a subject near the center according to the shooting aim.

Spot metering (☐)

Light is measured only for the specific region where the subject is located. This lets you adjust the exposure to the subject even when the subject is backlit or there is strong contrast between the subject and the background.

Position the spot metering cross hair on one point of the subject you want to shoot.

- When using center weighted metering or spot metering, to focus on the same spot as used for metering, we recommend using the center weighted AF range finder frame (page 48).

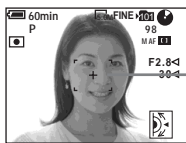

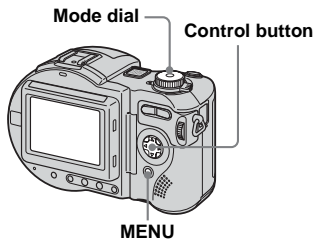

Spot metering cross hair



- 1** Set the mode dial to P, S, A, M, SCN or .

- 2** Press MENU.

The menu appears.

- 3** Select  (Metering Mode) with , then select [Multi], [Center] or [Spot] with .

Shooting with the exposure fixed

— AE LOCK

Mode dial: P/S/A/SCN/

Once you press AE LOCK, the exposure is fixed.

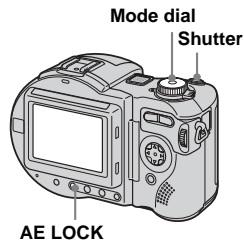

- 1** Set the mode dial to P, S, A, SCN or .

- 2** Focus on a portion of the image that has the desired exposure value, then press AE LOCK.

The exposure is fixed and the AE-L indicator appears.

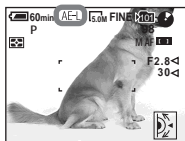

3 Target the subject you want to shoot and press and hold the shutter button halfway down.

The focus is automatically adjusted.

4 Press the shutter button fully down.

To release AE LOCK

Carry out one of the followings:

- Press AE LOCK again after step **2**.
- Release your finger from the shutter button after step **3**.
- Press down the shutter button in step **4**.

Shooting techniques

You can shoot with the exposure locked to a specific portion of the image.

Measure the exposure of the desired portion of the subject using the center weighted metering or spot metering function. Press AE LOCK to lock the exposure, and then recompose the picture and shoot.

Portion of the image used to determine the exposure



Shooting three images with the exposure shifted

— Exposure Bracket

Mode dial: /P/S/A/M/SCN

The camera records three images in succession, each with the exposure value shifted. The exposure compensation value can be set between $\pm 1.0\text{EV}$ from the appropriate exposure value in $1/3\text{EV}$ steps.

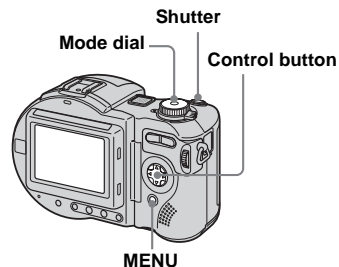



1 Set the mode dial to SET UP.

The SET UP screen appears.

2 Select  (Camera 2) with $\blacktriangle/\blacktriangledown$ and [Bracket Step] with $\blacktriangleright/\blacktriangleleft$, then press \blacktriangleright .

3 Select the desired bracket step value with $\blacktriangle/\blacktriangledown$, then press \bullet .

$\pm 1.0\text{EV}$: Shifts the exposure value by plus or minus 1.0EV.

$\pm 0.7\text{EV}$: Shifts the exposure value by plus or minus 0.7EV.

$\pm 0.3\text{EV}$: Shifts the exposure value by plus or minus 0.3EV.

4 Set the mode dial to , P, S, A, M or SCN.

5 Press MENU.

The menu appears.

6 Select [Mode] (REC Mode) with $\blacktriangleleft/\blacktriangleright$, then select [Exp Brktg] with $\blacktriangle/\blacktriangledown$.

7 Shoot the image.

To return to normal mode

Select [Normal] in step **6**.

- You cannot use the flash in this mode.
- During shooting in this mode, the images are not displayed on the screen. Compose the image before pressing the shutter button.
- The focus and white balance are adjusted for the first image, and these settings are also used for the other images.
- When the exposure is manually adjusted (page 51), the adjusted value is used for the center value.
- The recording interval is approximately 0.5 second.
- You cannot select a shutter speed of 1/6 second or slower.
- If the subject is too bright or too dark, you may be unable to shoot properly with the selected bracket step value.

Adjusting color tones

— White Balance

Mode dial: P/S/A/M/SCN/☰

When the white balance is set to Auto, the white balance is automatically set and the overall color balance is adjusted according to the shooting conditions. However, when you shoot under fixed conditions or special lighting conditions, you can manually adjust the white balance.

Auto (no display)

Adjusts the white balance automatically

☀ (Daylight)

Shooting outdoors, shooting night scenes, neon signs, fireworks or sunrises, or shooting just before and after sundown

☁ (Cloudy)

Shooting under a cloudy sky

☀ (Fluorescent)

Shooting under fluorescent lighting

☀ (Incandescent)

- Places where the lighting conditions change quickly
- Under bright lighting such as photography studios

WB (Flash)

Adjusts the white balance only to the flash conditions

☑ (One push)

For adjusting the white balance depending on the light source

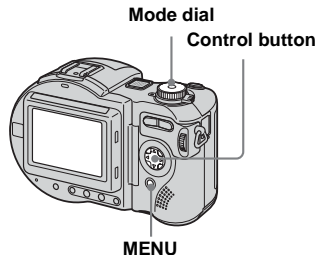

- 1 Set the mode dial to P, S, A, M, SCN or ☰.**
- 2 Press MENU.**
The menu appears.
- 3 Select [WB] (White Bal) with ◀/▶, then select the desired setting with ▲/▼.**

To reactivate auto adjustment

Select [Auto] in step 3.

- Under fluorescent lights that flicker, the white balance adjustment function may not work correctly even though you select ☰ (Fluorescent).
- When the flash strobes, the manual setting is canceled, and the image is recorded in [Auto] mode (except in WB (Flash) mode or ☑ (One push) mode).

To shoot in one-push white balance mode

- 1 Select [☑] (One push).**
The ☑ indicator appears.
 - 2 Frame a white object such as a piece of paper filling the screen under the same lighting conditions as you will shoot the subject.**
 - 3 Press ▲.**
The ☑ indicator flashes quickly.
When the white balance has been adjusted and stored in the memory, the indicator stops flashing.
- The ☑ indicator means:
Slow flashing: The white balance is not set or was not able to be set.
Quick flashing: The white balance is being adjusted (after you press ▲).
Lit steady: The white balance has been set.
 - Do not shake or strike the camera during quick flashing the ☑ indicator.
 - If the ☑ indicator keeps flashing even when you press ▲, record in automatic white balance mode.

- When you select the one-push white balance mode, the screen momentarily turns blue.
- When flash mode is set to ⚡ (Forced flash) or ⚡SL (Slow synchro), the white balance is adjusted to the condition with the flash emitting.

Shooting techniques

The subject coloring is affected by the lighting conditions. For example, the entire image appears blue under sunlight in the summer, and white items gain a reddish tint under incandescent light bulbs, etc. The human eye can resolve these problems, but digital still cameras cannot recognize the correct colors without adjustments. Normally, the camera makes these adjustments automatically, but if recorded image colors appear unnatural, we recommend that you adjust the white balance.

Adjusting the flash level

— Flash Level

Mode dial: P/S/A/M/SCN

You can adjust the amount of flash light.

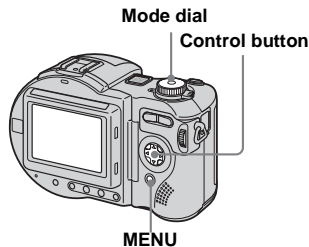

1 Set the mode dial to P, S, A, M or SCN.

2 Press MENU.

The menu appears.

3 Select [$\text{⚡}\pm$] (Flash Level) with $\blacktriangleleft/\blacktriangleright$, then select the desired setting with $\blacktriangle/\blacktriangledown$.

High: Makes the flash level higher than normal.

Normal: Normal setting.

Low: Makes the flash level lower than normal.

- You can carry out this operation even when the mode dial is set to Ⓜ (Clip Motion).

Shooting multiple frames

— Clip Motion

Mode dial:

You can shoot a number of consecutive still images (GIF animation). The GIF format has a small file size, making it convenient for creating home pages or attaching images to e-mail.

- Due to the limitations of the GIF format, the number of colors for Clip Motion images is reduced to 256 colors or less. Therefore, the image quality may deteriorate for some images.

Normal (160×120)

Clip Motion of up to 10 frames can be recorded. This is suitable for use on home pages, etc.

Mobile (120×108)





Clip Motion of up to two frames can be recorded. This is suitable for use with portable data terminals.

- The file size is reduced in Mobile mode, so the image quality deteriorates.

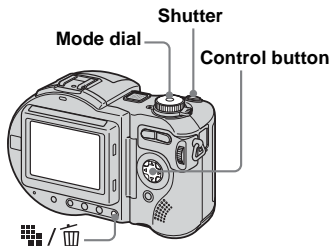
Before operation

Set [Moving Image] to [Clip Motion] in the SET UP settings (pages 41 and 116).



- 1 Set the mode dial to .**
- 2 Press  /  (Image Size).**
The Image Size setup appears.
- 3 Select the desired mode with  / .**

You can select from [Normal] or [Mobile].

- 4 Shoot the image for the first frame.**









- 5 Shoot the image for the next frame.**

Press the shutter button to shoot the next frame, then repeat this operation until you have shot the desired number of frames.

- 6 Press .**

All the frame images are recorded on the disc.

To delete some or all of the frame images while making a Clip Motion recording

- Press  () in step **4** or **5**.
The frame images you shot are played back in turn and stop at the last image.
- Press  /  (Delete), and select [Delete Last], or [Delete All] with  / , then press .

- 3 Select [Delete] with ▲, then press ●.
When [Delete Last] is selected in step 2, each time you repeat steps 1 through 3, the last frame you shot is deleted.

- Note that all images are not recorded on the disc until you carry out step 6.
- For the number of images that can be recorded in Clip Motion, see page 111.
- The date and time are not superimposed onto Clip Motion images.
- When viewing an image recorded in Clip Motion on the index screen, the image may appear different from the actual image.
- GIF files not created on this camera may not be displayed correctly.

Shooting in Multi Burst mode

— Multi Burst

Mode dial:



This mode records 16 frames in succession each time you press the shutter button. This is convenient for checking your form in sports, for example.

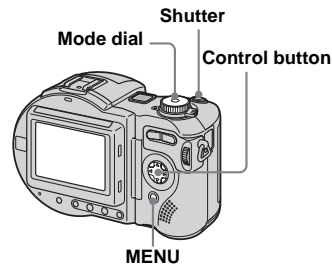

Before operation

Set [Moving Image] to [Multi Burst] in the SET UP settings (pages 41 and 116).



- 1 Set the mode dial to .
- 2 Press MENU.
The menu appears.
- 3 Select  (Interval) with ◀▶, then select the desired frame interval with ▲▼.

You can choose the frame interval from the menu settings (page 41).



4 Shoot the image.

The 16 frames are recorded as a single image (image size: 1.2M).

- See page 73 to play back images recorded in Multi Burst mode using this camera.
- For the number of images that can be recorded in Multi Burst mode, see page 111.
- You cannot use the flash in this mode.
- Date and time cannot be superimposed onto images.

Shooting three images continuously

— Burst 3

Mode dial: /P/S/A/M/SCN

This mode is used for continuous shooting. Each time you press the shutter button in this mode, the camera records three images in succession.

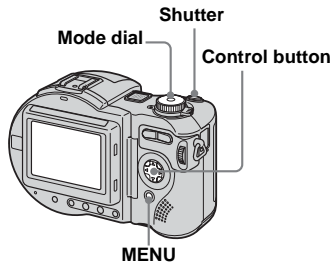

1 Set the mode dial to , P, S, A, M or SCN.

2 Press MENU.

The menu appears.

3 Select [Mode] (REC Mode) with / , then select [Burst 3] with / .



4 Shoot the image.

When the “Recording” indication disappears, you can shoot the next image.

To return to normal mode

Select [Normal] in step 3.

- You cannot use the flash in this mode.
- During shooting in this mode, the images are not displayed on the screen. Compose the image before pressing the shutter button.
- The recording interval is approximately 0.5 second.
- You cannot select a shutter speed of 1/6 second or slower.

Shooting still images in TIFF mode

— TIFF

Mode dial: /P/S/A/M/SCN

This mode records an image without compression, so the image quality does not deteriorate. Images recorded in this mode are suitable for editing on a computer, etc.

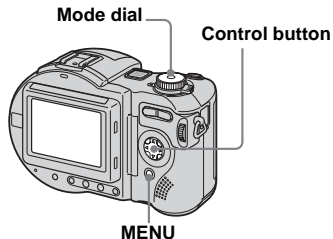

- 1** Set the mode dial to , P, S, A, M or SCN.
- 2** Press MENU.
The menu appears.
- 3** Select [Mode] (REC Mode) with / , then select [TIFF] with .
- 4** Shoot the image.

When the “Recording” indication disappears, you can shoot the next image.

To return to normal mode

Select [Normal] in step **3**.

- JPEG images are also recorded in the image size selected by the (Image Size) menu (page 20). Uncompressed (TIFF) images are recorded in [5.0M] size except when [4.5M (3:2)] is selected.
- Writing data takes more time than in normal recording mode.
- For the number of images you can record in TIFF mode, see page 110.

Shooting still images for e-mail

— E-Mail

Mode dial: /P/S/A/M/SCN

In E-mail mode, a small-size image (320×240) that is suitable for e-mail transmission is also recorded at the same time as recording a normal still image. (See page 20 for the normal still image sizes.)

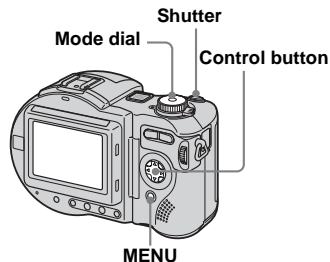

- 1** Set the mode dial to , P, S, A, M or SCN.
- 2** Press MENU.
The menu appears.

- 3 Select [Mode] (REC Mode) with ◀/▶, then select [E-Mail] with ▲/▼.

- 4 Shoot the image.

When the “Recording” indication disappears, you can shoot the next image.

To return to normal mode

Select [Normal] in step 3.

- For instructions on how to attach images to an e-mail message, consult the User’s Manual for your e-mail software.
- For the number of images you can record in E-mail mode, see page 110.

Shooting still images with audio files

— Voice

Mode dial: /P/S/A/M/SCN

In Voice mode, an audio track is also recorded at the same time as recording a normal still image.

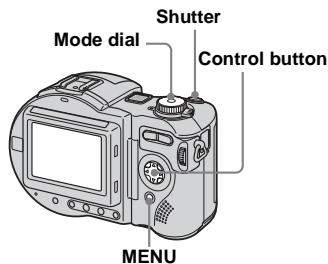

- 1 Set the mode dial to , P, S, A, M or SCN.

- 2 Press MENU.

The menu appears.

- 3 Select [Mode] (REC Mode) with ◀/▶, then select [Voice] with ▲/▼.

- 4 Shoot the image.

If you press and release the shutter button, sound is recorded for five seconds.

If you hold down the shutter button, sound is recorded until you release the shutter button for up to 40 seconds.

To return to normal mode

Select [Normal] in step 3.

- To view images recorded in Voice mode, carry out the same procedure described in “Viewing movies on the LCD screen” (page 81).
- For the number of images you can record in Voice mode, see page 110.

Shooting according to scene conditions

— Scene Selection

Mode dial: SCN

When shooting night scenes, shooting people at night, shooting landscapes, shooting portraits, shooting snowy scenes, or shooting at the shore, use the following modes to increase the quality of your images.

When the shutter speed is 1/6 second or slower, the NR slow shutter function activates automatically (page 46).

Twilight mode

Allows you to shoot night scenes at far distance without losing the dark atmosphere of the surroundings. The shutter speed becomes slower, so we recommend that you use a tripod to prevent shaking.



- You cannot shoot in macro mode.
- You cannot use the flash.

Twilight portrait mode

Suitable for shooting portraits in dark places. Allows you to shoot sharp images of people in dark places without losing the dark atmosphere of the surroundings. The shutter speed becomes slower, so we recommend that you use a tripod to prevent shaking.





- The flash strobos regardless of the surrounding brightness.

Landscape mode

Focuses on a distant subject to shoot landscapes, etc.



- You cannot shoot in macro mode.
- The flash is set to  (Forced flash) or  (No flash).

Portrait mode



Backgrounds blur away, and the subject is sharpened.



Snow mode

When shooting snowy scenes or other places where the whole screen appears white, use this mode to prevent sunken colors and record clear and sharp images.





- The flash is set to  (Forced flash) or  (No flash).

Beach mode

When shooting seaside or lakeside scenes, the blue of the water is clearly recorded.



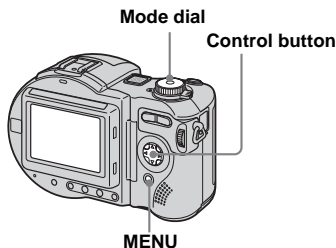

- The flash is set to  (Forced flash) or  (No flash).



1 Set the mode dial to SCN.

2 Press MENU.

The menu appears.

3 Select [SCN] with , then select the desired mode with .

To cancel Scene Selection

Set the mode dial to a different mode.

- When you record in Burst 3 mode or Bracket mode, the shutter speed becomes faster, so the image may not be recorded just as you intended.
- When the NR slow shutter function activates, shooting may take some time.
- The setting is maintained even when the power is turned off.

Adding special effects

— Picture Effect

Mode dial: P/S/A/M/SCN/

You can digitally process images to obtain special effects.

Solarize



The light contrast is clearer and the picture looks like an illustration.

Sepia







The picture is sepia-toned like an old photograph.

Neg.Art

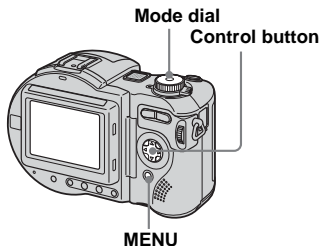

The color and brightness of the picture are reversed as in a negative.



- 1** Set the mode dial to P, S, A, M, SCN or .
- 2** Press MENU.
The menu appears.
- 3** Select [PFX] (P. Effect) with , then select the desired mode with .

To cancel Picture Effects

Select [Off] in step **3**.





Confirming whether to record images

— Confirm before write

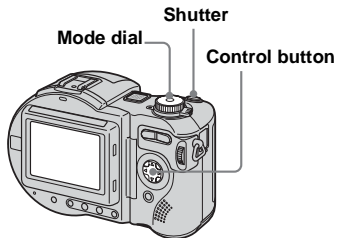
Mode dial:  / P / S / A / M / SCN

When this function is activated, recorded images are temporarily stored in the camera memory, letting you confirm whether or not to save the images you have recorded on a disc. If you delete an unwanted image before recording, the disc remaining space does not decrease.





- 1** Set the mode dial to SET UP.
- 2** Select  (Disc Tool 2) with , [Confirm B. Write] with , and [On] with , then press .

3 Set the mode dial to , P, S, A, M or SCN.

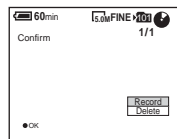
4 Record the image.





5 Select [Record] or [Delete] with , then press .

If you select [Record]

“Recording” appears on the screen, and the image will be recorded on the disc.

If you select [Delete]

Select [Delete], then press  to not record the image on the disc. Select [Cancel], then press  to return to the previous screen.

- You can carry out this operation even when the mode dial is set to  (Multi Burst).

To confirm recording of images shot in the Exposure Bracket or Burst 3 modes

You can confirm whether to record each of the images by pressing ◀▶ in step 5 and displaying the three images in order.

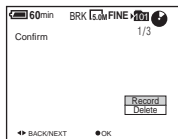

Using an external flash

Mode dial: / P / S / A / M / SCN

Using an external flash will allow you to shoot more vivid flash pictures than when using an internal flash.

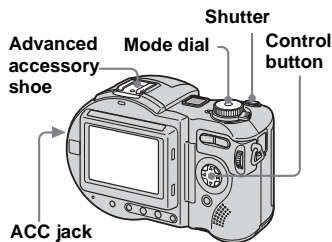

- The flash does not strobe when shooting in Burst 3, Exposure Bracket, (Twilight mode), MPEG Movie or Multi Burst mode.
- You cannot have an external flash and the built-in flash strobe at the same time.
- Note that when shooting with two or more external flashes, the camera functions may not operate normally, or the camera may malfunction.
- You can carry out this operation even when the mode dial is set to (Clip Motion).

Using the Sony HVL-F32X Flash

You can mount the Sony HVL-F32X flash on the advanced accessory shoe of your camera. The HVL-F32X is also equipped with automatic flash level adjustment and AF fill light shooting functions.

- 1** Mount the HVL-F32X external flash on the advanced accessory shoe.
- 2** Turn on the HVL-F32X.
- 3** Set the mode dial to , P, S, A, M or SCN.
- 4** Shoot the image.

- When using a Sony optional external flash, check that [Hot Shoe] is set to [Off] in the SET UP settings.

Using the Sony HVL-F1000 Flash

You can mount the Sony HVL-F1000 flash on the advanced accessory shoe of your camera.

1 Mount the HVL-F1000 external flash on the advanced accessory shoe.

2 Plug the flash into the ACC jack.

3 Turn on the HVL-F1000.

4 Set the mode dial to , P, S, A, M or SCN.

5 Shoot the image.

- When using a Sony optional external flash, check that [Hot Shoe] is set to [Off] in the SET UP settings.

Using a commercially available external flash

You can mount a commercially available external flash that supports advanced accessory shoe.

1 Mount the external flash to the advanced accessory shoe.



2 Set the mode dial to SET UP.

3 Select  (Camera 2) with , [Hot Shoe] with , [On] with , then press .

4 Turn on the external flash.

For details, please consult the operating instructions supplied with your flash.

5 Set the mode dial to M or A.

The flash also strobes when the mode dial is set to , P, S, SCN or  (Clip Motion), but we recommend recording with the mode dial set to M or A.

6 Shoot the image.

- Set the most appropriate aperture value according to the guide number of the flash used and the distance to the subject.
- The flash guide number varies according to the ISO sensitivity (page 112) of the camera, so be sure to check the ISO number.
- Note that the camera may not function properly or may malfunction when using a flash manufactured by another company for a specific camera (generally a flash with multiple contact points on the advanced accessory shoe), a high-voltage type flash, or a flash accessory.
- If you record with [Hot Shoe] set to [Off] in the SET UP settings, the built-in flash may rise up. If this happens, return the built-in flash to its original position and set [Hot Shoe] to [On].

Selecting the folder and playing back images

— Folder

Mode dial: ►

Select the folder that images you want to playback are stored.

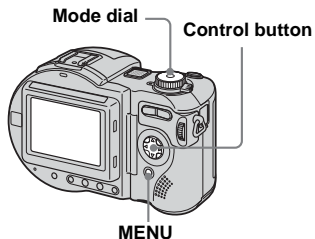

1 Set the mode dial to ►.

2 Press MENU.

The menu appears.

3 Select [Folder] with ◀, then press ●.

4 Select the desired folder with ◀▶.

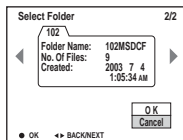

5 Select [OK] with ▲, then press ●.



To cancel the selection

In step **5**, select [Cancel].

When multiple folders are created in the disc

When the first or last image in the folder is displayed, the following indicators appear on the screen.



Moves to the previous folder.



Moves to the next folder.



Moves to both the previous and next folders.

Single screen



Index (nine-image) screen



Index (triple-image) screen

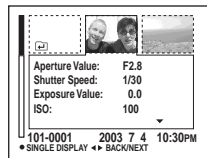

- When no images are stored in the folder, “No file in this folder” appears.
- You can playback images from a last-shot one without selecting the folder.



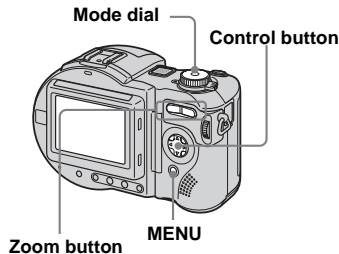

Enlarging a portion of a still image

Mode dial: 

You can enlarge a part of an image up to five times the original size. You can also record the magnified image as a new file.



Enlarging an image — Playback zoom

- 1 Set the mode dial to .
- 2 Display the image to be enlarged.
- 3 Press the zoom T button to zoom in on the image.
- 4 Select the desired portion of the image with ///.



- ▲: To view more of the top of the image
- ▼: To view more of the bottom of the image
- ◀: To view more of the left side of the image
- ▶: To view more of the right side of the image

- 5 Adjust the image size with the zoom W/T button.



To cancel playback zoom

Press .

- You cannot use playback zoom for movies (MPEG Movie), Clip Motion images and Multi Burst images.
- If you press the zoom W button while a non-enlarged image is displayed, the LCD screen switches to the index screen (page 33).
- You can enlarge the images displayed with the Quick Review function (page 24) by performing steps **3** to **5**.

Recording an enlarged image — *Trimming*

1 Press MENU after playback zoom.

The menu appears.

2 Select [Trimming] with \blacktriangleright , then press \bullet .

3 Select the image size with $\blacktriangle/\blacktriangledown$, then press \bullet .

The image is recorded, and the image on the screen returns to the normal size after recording.

- The trimmed image is recorded as the newest file in the selected recording folder, and the original image is retained.
- The quality of trimmed images may deteriorate.
- You cannot trim to an image size of 3:2.
- You cannot trim uncompressed (TIFF) images.
- You cannot trim images displayed with Quick Review.
- If you trim an image, the disc remaining space will decrease.
- If the disc remaining space is not sufficient, you may be unable to trim an image.

Playing back successive images

— Slide Show

Mode dial: \blacktriangleright

You can play back recorded images in order. This function is useful for checking your images or for presentations, etc.

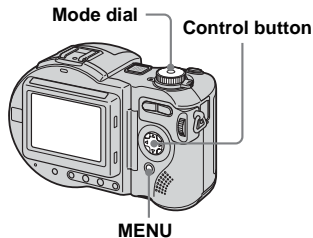

1 Set the mode dial to \blacktriangleright .

2 Press MENU.

The menu appears.

3 Select [Slide] with $\blacktriangle/\blacktriangleright$, then press \bullet .

Set the following items with $\blacktriangle/\blacktriangledown/\blacktriangle/\blacktriangleright$.

Interval

5 sec/10 sec/30 sec/1 min

Image

Folder: Plays back all images in the selected folder.

All: Plays back all images stored in the disc.

Repeat

On: Plays back images in a continuous loop (approx. 20 min.)*.

Off: After all the images have been played back, the slide show ends.

* The slide show does not end until all the images have been played back, even if the playback time exceeds 20 minutes.

4 Select [Start] with $\blacktriangledown/\blacktriangleright$, then press \bullet .

The slide show begins.

To cancel the Slide Show setting

Select [Cancel] in step **3**.

To stop slide show playback

Press ●, select [Exit] with ►, then press ● again.

To skip to the next/previous image during the slide show

Press ► (next) or ◀ (previous).

- The interval setting time is approximate, and may vary according to the playback image size.

Rotating still images

— Rotate

Mode dial: ►

You can rotate an image recorded in portrait orientation and display it in landscape orientation.

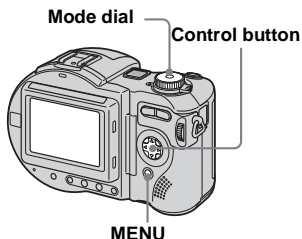

1 Set the mode dial to ►, and display the image to rotate.

2 Press MENU.

The menu appears.

3 Select [Rotate] with ►, then press ●.

4 Select ↶ ↷ with ▲, then rotate the image with ◀/►.

5 Select [OK] with ▲/▼, then press ●.

To cancel rotation

Select [Cancel] in step **4** or **5**, then press ●.

- You cannot rotate protected images and images recorded as movies (MPEG Movie), Clip Motion, Multi Burst and uncompressed (TIFF) images.
- You may not be able to rotate images shot with other cameras.
- When viewing images on a computer, the image rotation information may not be reflected depending on the application software.
- If you rotate an image, the disc remaining space will decrease.
- If the disc remaining space is not sufficient, you may not be able to rotate an image.

Playing back images shot in Multi Burst mode

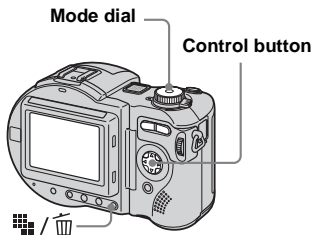

Mode dial:

You can play back Multi Burst images continuously or play them back frame by frame. This function is used for checking the image.



- When Multi Burst images are played back on a computer or on a camera without the Multi Burst function, the 16 frames you shot will be displayed at the same time as part of one image.



Playing back continuously

- 1** Set the mode dial to .
- 2** Select the Multi Burst image with  .

The selected Multi Burst image is played back continuously.







To pause playback

Press . To resume playback, press  again. The playback starts from the frame displayed on the LCD screen.







Playing back frame by frame

— Jog playback

- 1** Set the mode dial to .
- 2** Select the Multi Burst image with  .
- 3** Press  when the desired frame is displayed.

“Step” appears.





- 4** Advance the frame with  .
 - : A next frame is displayed. When you keep and press , the frame advances.
 - : A previous frame is displayed. When you keep and press , the frame advances in the reverse direction.

To return to the normal playback

Press ● in step 4. The playback starts from the frame displayed on the LCD screen.

To delete shot images

When using this mode, you cannot delete only certain frames. When you delete images, all 16 of the frames are deleted at the same time.

- 1 Display the desired Multi Burst image to delete.
- 2 Press  /  (Delete).
- 3 Select [Delete], then press ●.
All of the frames are deleted.

Protecting images

— Protect

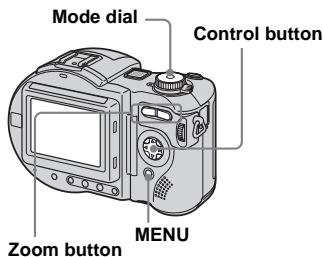

Mode dial: 

This function protects images against accidental erasure.







- If you protect an image, the disc remaining space will decrease. If you cancel the protection, the disc remaining space will also decrease.
- If the disc remaining space is not sufficient, you may not be able to protect an image.
- It may take some time to protect the images.

In single-image mode



- 1** Set the mode dial to .
- 2** Display the image you want to protect with / .
- 3** Press MENU.

The menu appears.

- 4** Select [Protect] with / , then press .

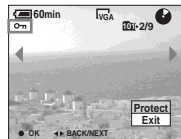
The displayed image is protected. The  (protect) indicator appears on the image.













- 5** To continue and protect other images, select the desired image with / , then press .

To cancel the protection

Press  again in step **4** or **5**. The  indicator disappears.

In index (nine-image) mode

- 1** Set the mode dial to , then press the zoom W (index) to display the index (nine-image) screen.
 - 2** Press MENU.
- The menu appears.
- 3** Select [Protect] with , then press .
 - 4** Select [Select] with , then press .
 - 5** Select the image you want to protect with / / , then press .

The green  indicator appears on the selected image.



- 6** Repeat step **5** to protect other images.

7 Press MENU.

8 Select [OK] with **▶**, then press **●**.

The **☞** indicator turns white. The selected images are protected.

To exit the Protect function

Select [Cancel] in step **4** or select [Exit] in step **8**, then press **●**.

To cancel individual protection

Select the image to be unprotected with **▲/▼/◀/▶**, then press **●** in step **5**. The **☞** indicator turns gray. Repeat this operation for all images that are to be unprotected. Press MENU, select [OK], and then press **●**.

To protect all images in the folder

Select [All In Folder] in step **4**, and press **●**. Select [On], then press **●**.

To cancel all protection of all images in the folder

Select [All In Folder] in step **4**, and press **●**. Select [Off], then press **●**.

In index (triple-image) mode

1 Set the mode dial to **▶**, then press the zoom W (index) twice to display the index (triple-image) screen.

2 Display the image you want to protect in the center position with **◀/▶**.

3 Press MENU.

The menu appears.

4 Select [Protect] with **▲/▼**, then press **●**.

The center image is protected. The **☞** indicator appears on the image.

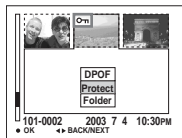

5 To protect other images, display the image you want to protect in the center position with **◀/▶**, and repeat step **4**.

To cancel previously set protection

Select the image to be unprotected, and press **●** in step **4**. To cancel protection of all images, repeat this process for each image.

Changing image size

— Resize

Mode dial: 

You can change the image size of a recorded image, and save it as a new file. You can resize to the following sizes. 5.0M, 3.1M, 1.2M, VGA
The original image is retained even after resizing.

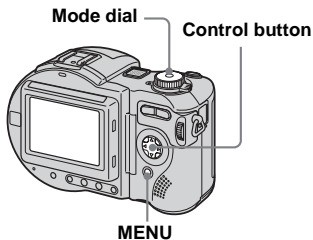

1 Set the mode dial to .

2 Display the image you want to resize with / .

3 Press **MENU**.

The menu appears.

4 Select **[Resize]** with / , then press .

5 Select the desired size with / , then press .

The resized image is recorded in the recording folder as the newest file.

To cancel resizing

Select **[Cancel]** in step **5**.

- You cannot change the size of movies (MPEG Movie), Clip Motion, Multi Burst or uncompressed (TIFF) images.
- When you change from a small size to a large size, the image quality deteriorates.
- You cannot resize to an image size of 3:2.
- When you resize a 3:2 image, the upper and lower black portions will be displayed on the image.
- If you resize an image, the disc remaining space will decrease.
- If the disc remaining space is not sufficient, you may not be able to resize an image.

Choosing images to print

— Print (DPOF) mark

Mode dial: 



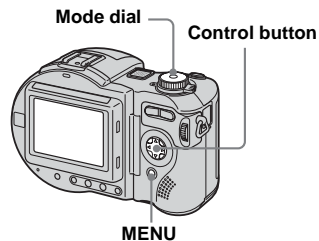



You can mark still images shot with your camera that you want to have printed. This function is convenient when you have images printed at a shop or using a printer that conforms with the DPOF (Digital Print Order Format) standard.



- You cannot mark movies (MPEG Movie) or Clip Motion images.
- In E-mail mode, a print (DPOF) mark is marked on the normal size image that is recorded at the same time.
- When you mark images shot in Multi Burst mode, all the images are printed on one image divided into 16 frames.



- If you mark an image shot in TIFF mode with a print (DPOF) mark, only the uncompressed (TIFF) image is printed, and the JPEG image recorded at the same time is not printed.
- If you mark an image with a print mark, the disc remaining space will decrease. If you unmark the print mark, the disc remaining space will also decrease.
- If the disc remaining space is not sufficient, you may not be able to mark an image with a print mark.
- Make sure to finalize the disc before having images printed at a shop that supports the DPOF standard (page 85).

In single-image mode

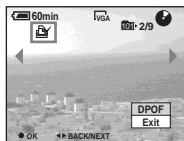

- 1** Set the mode dial to .
- 2** Display the image you want to mark with / .
- 3** Press MENU.
The menu appears.
- 4** Select [DPOF] with / , then press .

The  mark is marked on the displayed image.















- 5** To continue and mark other images, display the desired image with / , then press .

To unmark the mark

Press  again in step **4** or **5**. The  mark disappears.

In index (nine-image) mode

- 1** Set the mode dial to , then press the zoom W (index) to display the index (nine-image) screen.
- 2** Press MENU.
The menu appears.
- 3** Select [DPOF] with , then press .
- 4** Select [Select] with / , then press .
- 5** Select the image you want to mark with / / / , then press .

- When marking  marks, you cannot select [All In Folder].



The green  mark appears on the selected image.



- 6** Repeat step **5** to mark other images.

7 Press MENU.

8 Select [OK] with **▶**, then press **●**.

The  mark turns white. The  mark setting is completed.

To unmark marks

Select the images to be unmarked in step **5**, then press **●**.

To unmark all the marks in the folder

Select [All In Folder] in step **4**, then press **●**. Select [Off], then press **●**.

To exit the mark function

Select [Cancel] in step **4**, or select [Exit] in step **8**.

In index (triple-image) mode

1 Set the mode dial to **▶**, then press the zoom W (index) twice to display the index (triple-image) screen.

2 Display the image you want to mark in the center position with **◀/▶**.

3 Press MENU.

The menu appears.

4 Select [DPOF] with **▲**, then press **●**.

The  mark is marked on the center image.

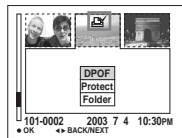

5 To continue and mark other images, display the image you want to print in the center position with **◀/▶**, and repeat step **4**.

To unmark the mark

Press **●** again in step **4**. The  mark disappears. Repeat this operation for all the images you want to unmark.

Shooting movies

Mode dial:

You can shoot movies with sound (MPEG movies) using your camera.

Before starting

Set [Moving Image] to [MPEG Movie] in the SET UP settings (pages 41 and 116).

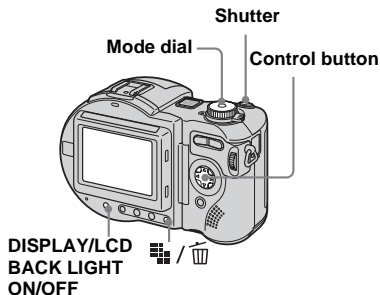

1 Set the mode dial to .

2 Press  /  (Image Size).

The Image Size setup appears.

3 Select the desired size with  / .

You can choose from 640 (VGA), 160 (Mail).

For details on the recording time for each image size, see page 111.

4 Press the shutter button fully down.

“REC” appears on the screen and the camera starts recording the image and sound.



• Recording stops when the disc is full.

5 Press the shutter button fully down again to stop recording.

Indicators during shooting

The screen indicators are not recorded.

Each time you press DISPLAY/LCD BACK LIGHT ON/OFF, the status of the LCD screen changes as follows: Indicators off → LCD backlight off → All indicators on.

A histogram is not displayed.

For a detailed description of the indicators, see page 126.

Shooting close-ups (Macro)

Set the mode dial to  and follow the procedure on page 26.

Using the self-timer

Set the mode dial to  and follow the procedure on page 27.

- Do not touch the microphone during shooting movies.
- You cannot use the flash.
- The date and time are not superimposed onto movies.
- The zoom magnification cannot be changed while shooting movies.

Viewing movies on the LCD screen

Mode dial: 

You can view movies on the LCD screen with sound from the speaker.

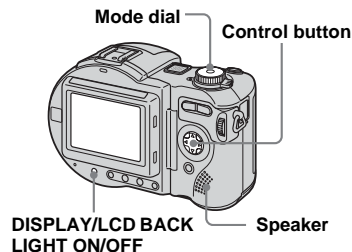

1 Set the mode dial to .

2 Select the desired movie with  .

Movies with the image size [160 (Mail)] are displayed a size smaller.

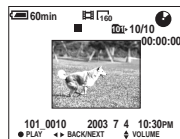

- Movies with the image size [640 (VGA)] are displayed on the full screen.

3 Press .

The movie and sound are played back. During playback,  (Playback) appears on the screen.

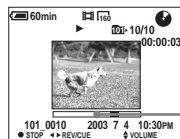

Playback bar



To stop playback

Press  again.

To adjust the volume

Press   to adjust the volume.

To advance or rewind the movie

Press   during playback.

To return to the normal playback, press .

Indicators during viewing movies

Each time you press DISPLAY/LCD BACK LIGHT ON/OFF, the status of the screen changes as follows: Indicators off → LCD backlight off → All indicators on. A histogram is not displayed.

For a detailed description of the indicators, see page 128.

- The procedure for viewing movies on a TV is the same as that for viewing still images (page 34).
- The movies recorded using earlier Sony models may be also displayed a size smaller.



Deleting movies

— Delete



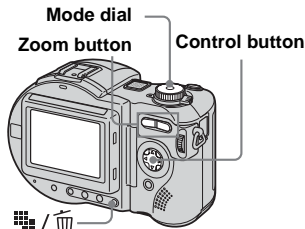





Mode dial: 

You can delete unwanted movies.



- When using a CD-R, the disc remaining space does not increase even if you delete images.
- When using a CD-RW, the disc remaining space only increases if you delete the last image you shot while  is indicated on the LCD screen. If you modify an image, or open and close the disc cover,  disappears.
- If the disc remaining space is not sufficient, you may not be able to delete an image.











In single-image mode

- 1** Set the mode dial to .
- 2** Display the movie you want to delete with / .
- 3** Press  /  (Delete).
The movie has not yet been deleted at this point.
- 4** Select [Delete] with , then press .
- When the message “Disc access” disappears, the movie has been deleted.
- 5** To continue and delete other movies, display the movie you want to delete with / , and repeat step **4**.

To cancel deletion

Select [Exit] in step **4** or **5**, then press .

In index (nine-image) mode

- 1** Set the mode dial to , then press the zoom W (index) to display an index (nine-image) screen.
- 2** Press  /  (Delete).
- 3** Select [Select] with / , then press .
- 4** Select the movie you want to delete with / / / , then press .

The green  (Delete) indicator appears on the selected movie.



The movie has not yet been deleted at this point.

- 5** Repeat step **4** to delete other movies.
- 6** Press  /  (Delete).

7 Select [OK] with ►, then press

●.
When the message “Disc access” disappears, the movies have been deleted.

To cancel deletion

Select [Exit] in step **3** or **7**.

To delete all movies in the folder

Select [All In Folder] in step **3**, then press

●. To cancel deletion, select [Cancel] with ◀, then press ●.

In index (triple-image) mode

1 Set the mode dial to ►, then press the zoom W (index) twice to display an index (triple-image) screen.

2 Display the movie you want to delete in the center position with ◀/▶.

3 Press  /  (Delete).

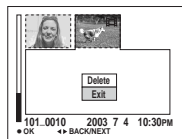

The movie has not yet been deleted at this point.

4 Select [Delete] with ▲, then press ●.

When the message “Disc access” disappears, the middle-positioned movie has been deleted.

To cancel deletion

Select [Exit] in step **4**, then press ●.

Viewing images on your computer

— Introduction

There are two methods for viewing images on a computer.

- Viewing images using a CD-ROM drive (page 85). (Windows only)
- Copying images into your computer through a USB connection (page 91, 97). (Windows and Mac OS X only)

Recommended computer environment

■ **Recommended Windows environment**

OS: Microsoft Windows 98, Windows 98SE, Windows 2000 Professional, Windows Millennium Edition, Windows XP Home Edition, or Windows XP Professional

The above OS must be installed at the factory. Operation is not assured in an environment upgraded to the operating systems described above or in a multi-boot environment.

CPU: MMX Pentium 200 MHz or faster

USB connector: Provided as standard

Display: 800 × 600 dots or more
High Color (16-bit color, 65,000 colors) or more

■ **Recommended Macintosh environment**

OS: Mac OS X (v10.0/v10.1/v10.2)

Only USB connection is possible.

You cannot view the contents of discs using the CD-ROM drive.

USB connector: Provided as standard

Display: 800 × 600 dots or more
32,000-color mode or more

- If you connect two or more USB equipment to a single computer at the same time, some equipment, including your camera, may not operate depending on the type of USB equipment.
- Operations are not guaranteed when using a USB hub.
- Operations are not guaranteed for all the recommended computer environments mentioned above.

Communication with your computer

When your computer resumes from the suspend or sleep mode, communication between your camera and your computer may not recover at the same time.

When a USB connector is not provided on your computer

You can copy images using a CD-ROM drive. Finalize the disc beforehand (Windows only).

Viewing images using CD-ROM drive

Finalizing a disc

You must execute finalization before viewing images recorded with your camera through a CD-ROM drive. Discs that have not been finalized cannot be read with a CD-ROM drive.

What is finalization?

- Finalization is required to view images recorded with your camera through a CD-ROM drive.
- You can record new images on a finalized disc by initializing it again. Initialization is automatically performed when a disc is finalized using the camera. You must execute finalization to view new images through a CD-ROM drive. However, each time you execute finalization, the disc remaining space will decrease by approximately 13 MB. Therefore, we recommend that you execute finalization for multiple images at a time.
- You can finalize a disc later, even if you remove it from the camera.
- The CD-ROM drive must support MultiRead in order to read discs that have been finalized.

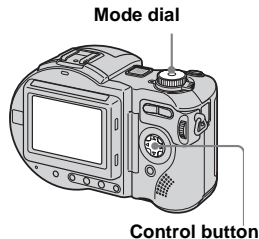

- 1** Set the mode dial to SET UP, and turn on the power.

The SET UP screen appears on the LCD screen.

- During finalization, we recommend using the AC Adaptor to prevent the power from turning off partway.

- 2** Select  (Disc Tool 1) with **▲** **▼** on the control button, then press **▶**.
Select [Finalize] with **▲**, then press **▶**.

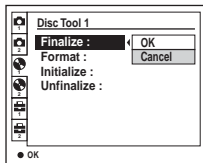

- 3** Select [OK] with **▲** on the control button, then press **●**.

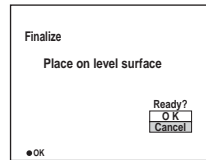



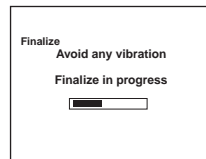

“Finalize Place on level surface” appears on the LCD screen.

- 4** Select [OK] again with **▲** on the control button, then press **●**.



When “Finalize in progress” disappears, finalization has been completed.

Finalization starts and the disc remaining indicator changes from  to , or from  to . Finalization may take some time. Place the camera on a stable surface, and do not shake or strike the camera during finalization.

To cancel finalization

Select [Cancel] with ▼ on the control button in step 3 or 4, then press ●. Once finalization starts, you cannot cancel it.

Canceling finalization (Unfinalize) (CD-RW only)

- 1 Place the CD-RW you want to unfinalize in the disc tray.
Set the mode dial to 📷.

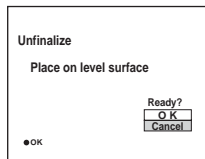

“Unfinalize Place on level surface” appears on the LCD screen.

- You can also carry out this operation when the mode dial is set to P, S, A, M, SCN or 📷.
- You can cancel the last-executed finalization (unfinalization). Once canceled, the disc space used for that finalization is recovered.

- 2 Select [OK] with ▲ on the control button, then press ●.

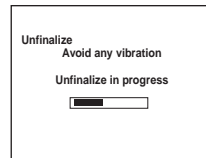

When “Unfinalize in progress” disappears, unfinalization has been completed.

Unfinalization starts and the disc remaining indicator changes from 📷 to 📷.

Unfinalization may take some time. Place the camera on a stable surface, and do not shake or strike the camera during unfinalization.

To cancel the unfinalization

Select [Cancel] with ▼ on the control button in step 1, then press ●.

To unfinalize again after canceling the unfinalization

Set the mode dial to SET UP, then select [Unfinalize] under 📷 (Disc Tool 1) in the SET UP settings (pages 41 and 117).

- You cannot execute unfinalization when you record a new image or edit an image on a CD-RW after executing finalization.

Using the supplied 8cm CD adaptor

- 1** Slide the disc into the inner groove and under two of the tabs on the inner circle of the adaptor in the order shown by the numbers.

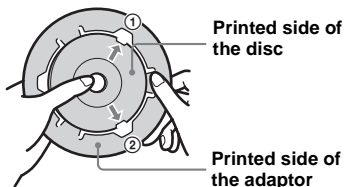

If your CD-ROM drive does not support 8 cm CD, use the supplied 8 cm CD adaptor.

- The supplied adaptor may not be compatible with your CD-ROM drive. For details, see the operating instructions for the CD-ROM drive.
- The reverse side of the disc is the recordable surface.
- “SONY” is printed on the reverse side of the adaptor and the surface is lustrous.

- 2** Pull the third tab to the outside and slip the disc into place. Release the third tab and the disc will be held firmly in place.

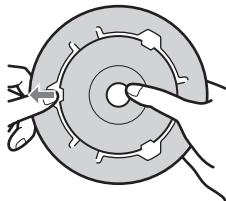

- Do not expose the adaptor to direct sunlight or heat sources.
- The adaptor can be used only with Mavica discs. It cannot be used with other 8 cm CD-R/CD-RW.

- 3** Check that the disc is set correctly in the grooves of the adaptor, all the tabs are even with the surface of the adaptor, and the disc does not protrude from the adaptor.

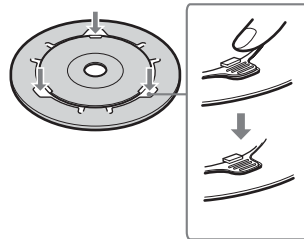

- If the tabs protrude, press them into place, as this may cause your CD-ROM drive to malfunction.

Viewing images through a CD-ROM drive

— Windows 98/98SE/2000/Me/XP

- 1 Start up your computer and insert a finalized disc into the CD-ROM drive of your computer.**

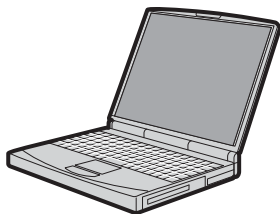

- To view images on a CD-RW using a CD-ROM drive, the drive must support MultiRead. Consult the drive manufacturer as to whether your drive supports MultiRead.
- This section describes how to view images through a CD-ROM drive using Windows Me as an example. The required operations may differ depending on your OS.
- You can use the “ImageMixer Ver. 1.5 for Sony” software to view images on your computer. For details, see page 92.

- 2 Open [My Computer] and double-click the drive you use for the disc (Example:[MV_20030101(E:)]).**

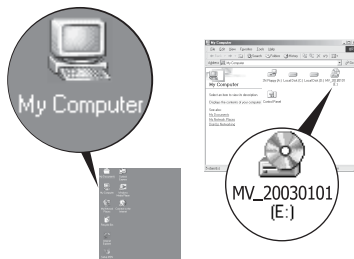

- 3 Double-click “DCIM,” then double-click the folder containing the image file you want to view.**

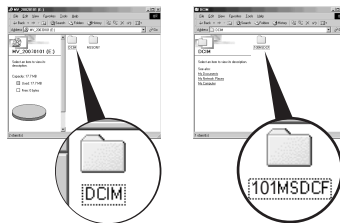

The folder contents are displayed.

- 4 Double-click the desired image file.**

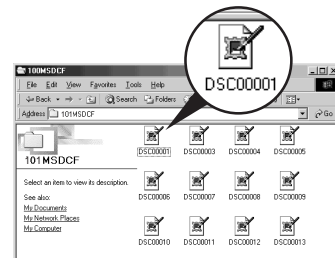

The file opens.

- Copying a file to the hard disk of your computer before viewing it is recommended. If you play back the file directly from the disc, the image and sound may break off.

Image file storage destinations and image file names

Image files recorded with your camera are grouped as folders in the disc.

Example: For Windows Me users

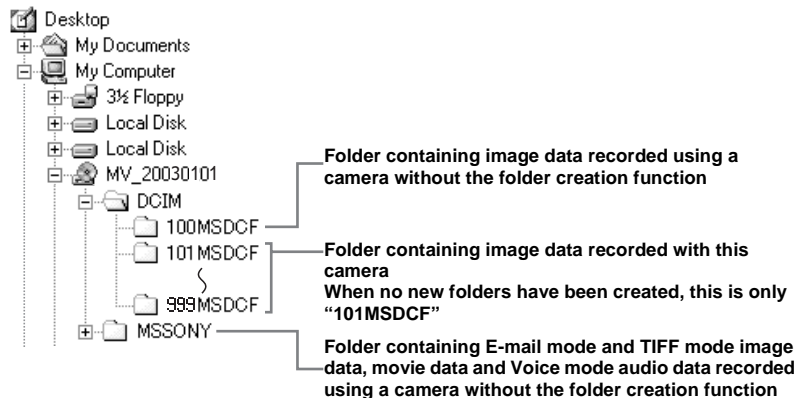

- Data in the "100MSDCF" or "MSSONY" folders is for playback only, and your camera cannot record images in these folders.
- For more information about the folder, see page 43.

Folder	File name	File meaning
101MSDCF up to 999MSDCF	DSC0□□□□.JPG	<ul style="list-style-type: none"> • Still image files shot in <ul style="list-style-type: none"> – Normal mode – Bracket mode (page 55) – Burst 3 mode (page 61) • Image files shot in Multi Burst mode (page 60) • Still image files recorded simultaneously in <ul style="list-style-type: none"> – E-Mail mode (page 62) – TIFF mode (page 62) – Voice mode (page 63)
	DSC0□□□□.JPE	• Small-size image files shot in E-Mail mode (page 62)
	DSC0□□□□.MPG	• Audio files shot in Voice mode (page 63)
	DSC0□□□□.TIF	• Uncompressed (TIFF) image file recorded in TIFF mode (page 62)
	CLP0□□□□.GIF	• Clip Motion files shot in Normal mode (page 59)
	CLP0□□□□.THM	• Index image files of Clip Motion files shot in Normal mode
	MBL0□□□□.GIF	• Clip Motion files shot in Mobile mode (page 59)
	MBL0□□□□.THM	• Index image files of Clip Motion files shot in Mobile mode
	MOV0□□□□.MPG	• Movie files shot in MPEG Movie mode (page 80)

- □□□□ stands for any number within the range from 0001 to 9999.
- The numerical portions of the following files are the same.
 - A small-size image file shot in E-Mail mode and its corresponding image file
 - An audio file shot in Voice mode and its corresponding image file
 - An uncompressed image file shot in TIFF mode and its corresponding image file
 - An image file shot with Clip Motion and its corresponding index image file

Copying images into your computer through a USB connection

- Close down all applications running on the computer before installing.
- When using Windows 2000 or XP, log on as administrator.



Installing the PTP Manager

— Windows 98/98SE/2000/Me

- When using Windows XP, you need not install the PTP Manager.
- Once the PTP Manager is installed, you need not install the PTP Manager again.

- 1 Start up your computer, and insert the supplied CD-ROM into the CD-ROM drive.**

Do not connect your camera to your computer at this time.

The model selection screen appears. If it does not appear, double-click  (My Computer) →  (ImageMixer) in that order.

- 2 Click [CD Mavica] on the model selection screen.**



The installing menu screen appears.

- 3 Click [PTP Manager USB Driver] on the installing menu screen.**



The “Choose Setup Language” screen appears.

- 4 Select the desired language then click [OK].**



“Welcome to the InstallShield Wizard for PTP Manager” screen appears.

- This section describes the English screen.

- 5 Click [Next].**

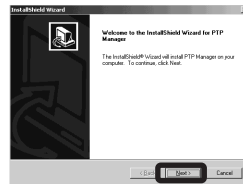

“Choose Destination Location” screen appears.

- 6 Select the destination folder, then click [Next].**



“Select Program Folder” screen appears.

- 7** Select [PTP Manager] as a program folder, then click [Next].

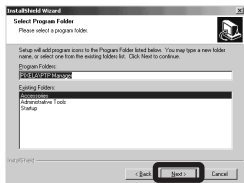

“Start Copying Files” screen appears.

- 8** Check the settings and click [Next].

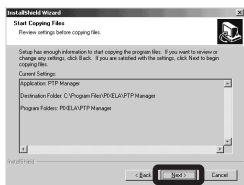

The PTP Manager installation starts. When installation finishes, “InstallShield Wizard Complete” screen appears.

- 9** Click [Finish].

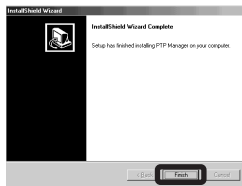

- 10** Select “Yes, I want to restart my computer now,” then click [Finish].

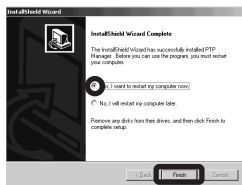

The computer turns off and then immediately on again (restart).

Installing “ImageMixer”

— Windows 98/98SE/2000/Me/XP

You can use the “ImageMixer Ver. 1.5 for Sony” software to copy, view and edit images. For details, see the software’s help files.

- 1** Click [ImageMixer] on the installing menu screen. Select the desired language, then click [OK].



The “Welcome to the InstallShield Wizard” screen appears.

- This section describes the English screen.

2 Follow instructions on each succeeding screen.

Install “ImageMixer” according to the screen.

- When you use Windows 2000 or Windows XP, install “WinASPI”.
- If DirectX8.0a or a later version is not installed in your computer, the “Information” screen appears. Follow the procedure on the screen to install.

3 Restart your computer according to the screen.

4 Remove the CD-ROM.

Connecting the camera to your computer

1 Insert the disc with the images you want to copy into the camera.

Connect the power cord (mains lead) to the AC Adaptor (supplied) and then to a wall outlet (wall socket).

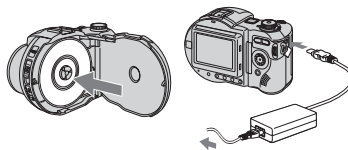

To a wall outlet (wall socket)

- For further details on the AC Adaptor, see page 14.
- For further details on the disc, see page 18.

2 Turn on your computer and the camera.

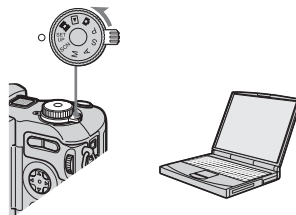

3 Open the jack cover, and connect the supplied USB cable to the ⚡ (USB) jack of the camera.

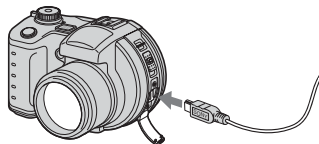

- 4** Connect the USB cable to your computer.

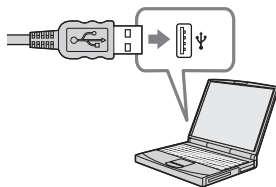

- When you use a desktop computer, we recommend that you connect the USB cable to the USB connector on the rear panel.
- When using Windows XP, the AutoPlay wizard automatically appears on the desktop. Proceed to page 96.

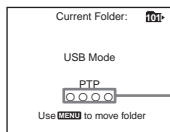

Access indicators*

“USB Mode PTP” appears on the LCD screen of the camera.

* During communication, the access indicators turn red.

It may take some time for your computer to recognize the disc.

- 1** Disconnecting the USB cable from your computer or removing the disc from your camera during USB connection

Windows 98/98SE/2000/Me Users

- 1 Click [Cancel] and close the window when using the PTP Manager.
- 2 Disconnect the USB cable from the jack on the computer, or remove the disc.

Copying images

- 1** Follow the steps on page 93 and make the USB connection, the PTP Manager starts. Click [Next].

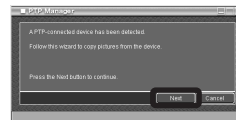

The images stored on the disc are displayed. It may take some time to load the images from the disc.

- 2** Select the images that you want to copy, then click [Next].



The “Copy Destination and Group Name Setup” screen appears.

The images in the selected recording folder appear.

To copy an image in a different folder, follow the procedure on page 43 and change the recording folder.

- 3 Specify the image group names to be copied and the copy destination, then click [Next].**



Image copying starts. When the copying is completed, the copying completed message appears.

- The images are copied into the “My Documents” folder as an example.

- 4 Click [Finish].**

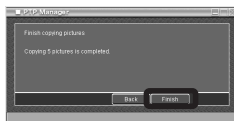

The Explorer starts up and the copy destination folder opens.

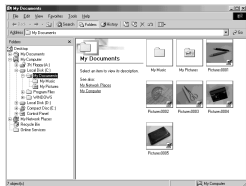

The images are copied to the copy destination folder.

When the PTP Manager does not start up

- 1 Right-click [My Computer], then click [Properties].
The “System Properties” screen appears.
 - When using Windows 2000, click [Hardware] tab on the “System Properties” screen.
- 2 Check whether the other device is already installed.
 - ① Click [Device Manager].
 - ② Check for a [📷 Sony PTP] with a 📷 mark.
- 3 If the device is installed, remove it.
 - ① Click [📷 Sony PTP].
(When using Windows 2000, right-click [📷 Sony PTP].)
 - ② Click [Remove] (or [Uninstall] in Windows 2000).
The “Confirm Device Removal” screen appears.
 - ③ Click [OK].
The device is deleted.

Try PTP Manager installation again using the supplied CD-ROM (page 91).

Copying images using the Windows XP AutoPlay Wizard

— Windows XP

1 Make a USB connection (page 93).

The “Scanner and Camera Wizard” screen appears.

2 Click [Next].

The images stored on the disc are displayed.

3 Click the checkbox of images that you do not want to copy to your computer and remove the checkmark, then click [Next].

The “Picture Name and Destination” screen appears.

4 Select a name and destination for your pictures, then click [Next].

Image copying starts. When the copying is completed, the “Other Options” screen appears.

5 Select [Nothing. I’m finished working with these pictures], then click [Next].

The “Completing the Scanner and Camera Wizard” screen appears.

6 Click [Finish].

The wizard closes.

Viewing images on your computer

1 Double-click [My Documents] on the desktop.

The “My Documents” folder contents are displayed.

2 Double-click the desired folder and image file.

The image is displayed.

- This section describes the procedure for viewing copied images in the “My Documents” folder.
- When using Windows XP, double-click [Start] → [My Documents] in that order.
- You can use the “ImageMixer Ver. 1.5 for Sony” software to view and edit images on your computer. For details, see the software’s help files.

Creating a Video CD

You can create Video CDs using commercially available 12 cm CD-R. For details, see the “ImageMixer” help files.

*For Mac OS X users (v10.0/
v10.1/v10.2)*

Mac OS X users can view images through a USB connection.

1 Connect your camera to your computer

For details, see page 93.

2 Connect the USB cable

For details, see page 94.

3 Copy the images using Image Capture

Image Capture starts up automatically. Follow the instructions appearing on the screen and copy the images.

- It may not be possible to copy movie files.

Troubleshooting

If you experience trouble with your camera, try the following solutions.

- 1 First check the items on the tables below.
If code displays “C:□□:□□” appear on the screen, the self-diagnosis display function is working (page 109).

- 2 Should your camera still not work properly, press the RESET button on the bottom of the camera using a fine-tipped object, then turn on the power again. (All the settings including date and time are cleared.)

RESET button

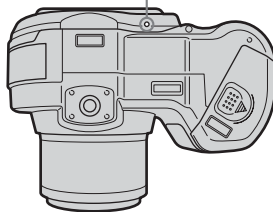







- 3 Should your camera still not work properly, consult your Sony dealer or local authorized Sony service facility.

















Battery pack and power



Symptom	Cause	Solution
You cannot charge the battery pack.	<ul style="list-style-type: none">• The camera is turned on.	→ Turn the camera off (page 15).
The battery pack cannot be installed.	<ul style="list-style-type: none">• The battery pack is not installed correctly.	→ Install the battery pack while pushing the battery eject lever up using the front edge of the battery pack (page 11).
The $\frac{1}{2}$ /CHG lamp flashes when charging a battery pack.	<ul style="list-style-type: none">• The battery pack is not installed correctly.• The battery pack has malfunctioned.	→ Install the battery pack correctly (page 11). → Consult your Sony dealer or local authorized Sony service facility.
The $\frac{1}{2}$ /CHG lamp does not light up when charging a battery pack.	<ul style="list-style-type: none">• The AC Adaptor is disconnected.• The battery pack is not installed correctly.• The battery pack is completely charged.	→ Properly connect the AC Adaptor (page 11). → Install the battery pack correctly (page 11). —

Symptom	Cause	Solution
The battery remaining indicator is incorrect, or sufficient battery remaining indicator is displayed but the power runs out soon.	<ul style="list-style-type: none"> You have used the camera for a long time in an extremely hot or an extremely cold location. The battery pack is dead (page 122). The battery pack is discharged. A deviation has occurred in the remaining battery time. 	<p>—</p> <ul style="list-style-type: none"> → Replace the battery pack with a new one. → Install a charged battery pack (page 11). → Fully charge the battery pack (page 12).
The battery pack runs down too quickly.	<ul style="list-style-type: none"> You are shooting/viewing images in an extremely cold location. The battery pack is not charged enough. The battery pack is dead (page 122). 	<p>—</p> <ul style="list-style-type: none"> → Charge the battery pack (page 11). → Replace the battery pack with a new one.
You cannot turn on the camera.	<ul style="list-style-type: none"> The battery pack is not installed correctly. The AC Adaptor is disconnected. The battery pack is discharged. The battery pack is dead (page 122). 	<ul style="list-style-type: none"> → Install the battery pack correctly (page 11). → Properly connect the AC Adaptor (page 14). → Install a charged battery pack (page 11). → Replace the battery pack with a new one.
The power turns off suddenly.	<ul style="list-style-type: none"> If you do not operate the camera for about three minutes when using a battery pack, the camera turns off automatically to prevent wearing down the battery (page 15). The battery pack is discharged. 	<ul style="list-style-type: none"> → Turn on the camera again (page 15) or use the AC Adapter (page 14). → Replace it with a charged battery pack (page 11).



Shooting still images/movies

Symptom	Cause	Solution
The LCD screen is not turned on even when the power is turned on.	<ul style="list-style-type: none"> The power was turned off with the LCD backlight turned off the last time you used the camera. 	→ Turn on the LCD backlight (page 30).
The subject is not visible on the screen.	<ul style="list-style-type: none"> The mode dial is not set to , P, S, A, M, SCN or . 	→ Set it to  , P, S, A, M, SCN or  (Clip Motion) (pages 22 and 80).
The image is out of focus.	<ul style="list-style-type: none"> The subject is too close. The  (Twilight mode) or  (Landscape mode) is selected for the Scene Selection function. The focus preset function is selected. [Conversion Lens] in the SET UP settings is set to [On]. 	→ Record in the macro recording mode. Make sure to position the lens farther away from the subject than the shortest shooting distance when shooting (page 26). → Set it to other modes (page 64). → Cancel the function (page 51). → Set it to [Off] (pages 41 and 117).
Zoom does not work.	<ul style="list-style-type: none"> [Conversion Lens] in the SET UP settings is set to [On]. The zoom magnification cannot be changed while shooting movies (MPEG Movie). 	→ Set it to [Off] (pages 41 and 117). —
Smart zoom does not function.	<ul style="list-style-type: none"> You cannot use smart zoom while shooting movies (MPEG Movie). [Smart Zoom] is set to [Off] in the SET UP settings. The image size is set to [5.0M] or [4.5M(3:2)]. 	— → Set [Smart Zoom] to [On] (pages 41 and 116). → Set image size to other settings except [5.0M] and [4.5M(3:2)].
The image is too dark.	<ul style="list-style-type: none"> You are shooting a subject with a light source behind the subject. The brightness of the LCD screen is too low. The LCD backlight is set to off. 	→ Adjust the exposure (page 51). → Adjust the brightness of the LCD screen (pages 41 and 118). → Turn the LCD backlight on (page 30).
The image is too bright.	<ul style="list-style-type: none"> You are shooting a spotlighted subject in a dark location such as on a stage. The brightness of the LCD screen is too bright. 	→ Adjust the exposure (page 51). → Adjust the brightness of the LCD screen (pages 41 and 118).

Symptom	Cause	Solution
Vertical streaks appear when you are shooting a very bright subject.	<ul style="list-style-type: none"> The smear phenomenon is occurring. 	→ This is not a malfunction.
Noise appears in the image when you view the LCD screen in a dark place.	<ul style="list-style-type: none"> The camera is functioning to increase the visibility of the LCD screen by temporarily brightening the image under conditions of low illumination. 	→ There is no effect on the recorded image.
Your camera cannot record images.	<ul style="list-style-type: none"> No disc has been inserted. The disc is full. The disc has not been initialized. You cannot record images while charging the flash. The mode dial is not set to , P, S, A, M or SCN when shooting a still image. The mode dial is not set to  when shooting a movie. 	→ Insert a disc (page 18). → Replace it with a new one. Format the disc when using a CD-RW. → Initialize the disc (page 19). — → Set it to  , P, S, A, M, or SCN (page 22). → Set it to  (page 80).
Recording takes a long time.	<ul style="list-style-type: none"> NR slow shutter function is activated. 	→ Set to a faster shutter speed than 1/6 second (page 46).
The built-in flash or the optional external flash (HVL-F32X/F1000) does not work.	<ul style="list-style-type: none"> The mode dial is not set to , P, S, A, M, SCN or  (Clip Motion). The flash is set to  (No flash). The  (Twilight mode) is selected for the Scene Selection function. The  (Landscape mode),  (Snow mode) or  (Beach mode) is selected for the Scene Selection function. [Moving Image] in the SET UP settings is set to [MPEG Movie] or [Multi Burst]. [Mode] (REC Mode) in the menu settings is set to [Burst 3] or [Exp Brktg]. [Hot Shoe] in the SET UP settings is set to [On]. 	→ Set it to  , P, S, A, M, SCN or  (Clip Motion) (pages 22 and 80). → Set the flash to auto (No indicator),  (Forced flash) or  (Slow synchro) (page 27). → Set it to other settings (page 64). → Set the flash to  (Forced flash) (page 27). → Set it to [Clip Motion]. → Set it to other settings. → Set it to [Off] (pages 41 and 117).

Symptom	Cause	Solution
The macro function does not work.	<ul style="list-style-type: none"> The  (Twilight mode) or  (Landscape mode) is selected for the Scene Selection function. 	→ Set it to other settings (page 64).
The eyes of the subject come out red.	—	→ Set [Red Eye Reduction] in the SET UP settings to [On] (pages 28 and 116).
The date and time are recorded incorrectly.	<ul style="list-style-type: none"> The date and time are not set correctly. 	→ Set the correct date and time (page 16).
The F value and shutter speed flash when you press and hold the shutter button halfway down.	<ul style="list-style-type: none"> The exposure is incorrect. 	→ Correct the exposure (page 51).

Viewing images

Symptom	Cause	Solution
Your camera cannot play back images.	<ul style="list-style-type: none"> The mode dial is not set to . Your camera cannot play back image files copied from the hard disk of your computer if the folder/file name has been changed or the image has been modified. The camera is in USB mode. 	<p>→ Set it to  (page 32).</p> <p>—</p> <p>→ Cancel USB communication (page 94).</p>
The image appears rough right after playback starts.	—	→ This is not a malfunction.
The image does not appear on the TV screen.	<ul style="list-style-type: none"> The video output signal setting of your camera in the SET UP settings is incorrect. The connection is not correct. 	<p>→ Change the setting (pages 41 and 118).</p> <p>→ Check the connection (page 34).</p>
The image cannot be played back on a computer.	—	→ See page 103.
Unknown beeps are heard from the camera while viewing a movie.	<ul style="list-style-type: none"> These beeps are heard when the auto focus is working. 	→ This is not a malfunction. Shoot the image using the focus preset (page 50).

Deleting/Editing Images

Symptom	Cause	Solution
Your camera cannot delete an image.	<ul style="list-style-type: none">• The image is protected.• The disc remaining space is not sufficient.	<p>→ Cancel the protection (page 75).</p> <p>→ This is not a malfunction.</p>
You have deleted an image by mistake.	<ul style="list-style-type: none">• Once you have deleted an image, you cannot restore it.	<p>→ Marking  (protect) will prevent you from deleting images by mistake (page 75).</p>
The resizing function does not work.	<ul style="list-style-type: none">• You cannot resize movies (MPEG Movie), Clip Motion, Multi Burst and uncompressed (TIFF) images.• The disc remaining space is not sufficient.	<p>—</p> <p>→ This is not a malfunction.</p>
You cannot display a print (DPOF) mark.	<ul style="list-style-type: none">• You cannot display print (DPOF) marks on movies and Clip Motion images.• The disc remaining space is not sufficient.	<p>—</p> <p>→ This is not a malfunction.</p>

Computers

Symptom	Cause	Solution
You do not know if the OS of your computer is compatible.	—	<p>→ Check “Recommended computer environment” (page 84).</p>
You cannot install PTP Manager.	—	<p>→ In Windows 2000, log on as Administrator (authorized Administrators) (page 91).</p>

Symptom	Cause	Solution
Your computer does not recognize your camera.	<ul style="list-style-type: none"> • The camera is turned off. • The battery level is low. • You are not using the supplied USB cable. • The USB cable is not connected firmly. • The camera was connected to a computer with the USB cable before installing PTP Manager, so the device was not recognized by the computer. • The USB connectors on your computer are connected to other equipment besides the keyboard, the mouse, and your camera. • PTP Manager is not installed. • The camera is not connected directly to your computer. 	<ul style="list-style-type: none"> → Turn on the camera (page 15). → Use the AC Adaptor (page 14). → Use the supplied USB cable (page 93). → Disconnect the USB cable, and connect it again firmly. Make sure that "USB Mode" is displayed on the screen (page 94). → Delete the device which is not recognized, then install PTP Manager (pages 95 and 91). → Disconnect the USB cables except for the ones connected to the keyboard, the mouse, and your camera. → Install PTP Manager (page 91). → Connect the camera directly to your computer without passing through a USB hub or other device.
You cannot copy images.	<ul style="list-style-type: none"> • The camera is not correctly connected to your computer. • You are not using the correct copy procedure for your OS. — 	<ul style="list-style-type: none"> → Connect the camera and your computer correctly using the USB cable (page 93). → Follow the designated copy procedure for your OS (pages 94, 96 and 97). → If you are using the "ImageMixer Ver. 1.5 for Sony" application software, click on HELP.
The image cannot be played back on a computer.	<ul style="list-style-type: none"> — — 	<ul style="list-style-type: none"> → If you are using the "ImageMixer Ver. 1.5 for Sony" application software, click on HELP. → Consult the computer or software manufacturer.
The image cannot be played back through the CD-ROM drive of your computer.	<ul style="list-style-type: none"> • The disc has not been finalized. • Vibration caused an error during recording. • The CD-ROM drive does not support the packet-write system. • The CD-ROM drive does not support the MultiRead. • The disc may be scratched or dirty. — 	<ul style="list-style-type: none"> → Finalize the disc (page 85). → You may be able to view the image if you connect the camera to your computer with the USB cable. → Consult the computer or the CD-ROM drive manufacturer. → Consult the computer or the CD-ROM drive manufacturer. → Clean the disc if the disc is dirty. When the disc is scratched replace the disc. → Causes not described above have occurred, consult the computer or software manufacturer.

Symptom	Cause	Solution
The image and sound are interrupted by noise when you view a movie on a computer.	<ul style="list-style-type: none"> You are playing back the file directly from the disc. 	→ Copy the file to the hard disk of your computer and then play back the file from the hard disk.
You cannot print an image.	— —	→ Check the printer settings. → Click on the HELP for the “ImageMixer Ver. 1.5 for Sony” application software.
An error message appears when you set the supplied CD-ROM in your computer.	<ul style="list-style-type: none"> The computer display is not set correctly. 	→ Set the computer display as follows: Windows: 800 × 600 dots or more High Color (16 bits, 65,000 colors) or more Macintosh: 800 × 600 dots or more 32,000-color or more

Disc

Symptom	Cause	Solution
You cannot record on a disc.	<ul style="list-style-type: none"> The disc is full. The disc is not initialized. The disc is not placed correctly. 	→ Replace it with a new one. Format the disc when using a CD-RW (page 39). → Initialize the disc (page 19). → Place the disc correctly in the disc tray (page 18).



Others

Symptom	Cause	Solution
Your camera does not work.	<ul style="list-style-type: none"> You are not using an “InfoLITHIUM” battery pack. The battery level is low. (The  indicator appears.) The AC Adaptor is not connected securely. 	<ul style="list-style-type: none"> → Use an “InfoLITHIUM” battery pack (page 121). → Charge the battery pack (page 11). → Connect it securely to the DC IN jack of your camera and to a wall outlet (page 14).
The power is on, but the camera does not work.	<ul style="list-style-type: none"> The built-in microcomputer is not working properly. 	<ul style="list-style-type: none"> → Disconnect, and then, after one minute, reconnect all power sources and turn on the camera. If this does not work, press the RESET button on the bottom of the camera with a pointed object, then turn the power on again. (This will clear the date and time settings, etc.)
You cannot identify an indicator on the screen.	—	<ul style="list-style-type: none"> → Check the indicator (page 125).
The lens gets fogged.	<ul style="list-style-type: none"> Moisture condensation has occurred. 	<ul style="list-style-type: none"> → Turn off the camera and leave for about an hour at room temperature for the moisture to evaporate before use (page 120).
The lens does not move when you turn off the camera.	<ul style="list-style-type: none"> The battery pack is discharged. 	<ul style="list-style-type: none"> → Replace it with a charged battery pack or use the AC Adaptor (pages 11 and 14).
A file error occurs when you play back a file.	<ul style="list-style-type: none"> The image file has an error. The image was not recorded correctly. The disc is dirty. The disc may be scratched. 	<ul style="list-style-type: none"> — — → Clean the disc (page 120). → Replace the disc.

Warnings and messages

The following messages may appear on the screen.

Message	Meaning/Corrective action
Lens cap attached	<ul style="list-style-type: none">• The lens cap is attached. Remove the lens cap.
Cover open	<ul style="list-style-type: none">• The disc cover is open. Close the disc cover (page 18).
No disc	<ul style="list-style-type: none">• No disc is inserted. Insert a disc (page 18).
Drive error	<ul style="list-style-type: none">• Trouble has occurred with the drive. Turn the power off and on again (page 15).
System error	<ul style="list-style-type: none">• Trouble has occurred with the drive or the camera. Turn the power off and on again (page 15).
Disc error	<ul style="list-style-type: none">• The inserted disc cannot be used with your camera, is damaged, is dirty, or cannot be read due to vibration.
Dew error	<ul style="list-style-type: none">• Moisture condensation has occurred inside the camera. Turn off the camera and wait for about an hour for the moisture to evaporate before use (page 120).
Disc protect	<ul style="list-style-type: none">• The disc was protected with a computer, and cannot be recorded.
No file in this folder	<ul style="list-style-type: none">• No images have been recorded in this folder.
Folder error	<ul style="list-style-type: none">• A folder with the same first three digits number already exists in the disc. (For example: 123MSDCF and 123ABCDE) Select other folders, or create a new folder.
Cannot create more folders	<ul style="list-style-type: none">• The folder whose first three digits of the name is “999” exists in the disc. You cannot create any folders.
Not enough disc space	<ul style="list-style-type: none">• The remaining disc space is insufficient for any operation other than finalization.
Not initialized	<ul style="list-style-type: none">• The disc has not been initialized, so images cannot be recorded by the camera. Initialize the disc (page 19).
Already initialized	<ul style="list-style-type: none">• The disc has already been initialized, so initialization is not necessary.
Already finalized	<ul style="list-style-type: none">• The disc has already been finalized, so finalization is not necessary.
Cannot record	<ul style="list-style-type: none">• The camera cannot record images in the selected folder. Select a different folder (page 44).
File error	<ul style="list-style-type: none">• An error occurred while playing back the image.
Image size over	<ul style="list-style-type: none">• You are playing back an image of a size larger than can be played back with your camera.
Invalid operation	<ul style="list-style-type: none">• You are playing back a file that was created on equipment other than your camera.
File protect	<ul style="list-style-type: none">• The image is protected against erasure. Release the protection (page 75).

Message	Meaning/Corrective action
For "InfoLITHIUM" battery only	<ul style="list-style-type: none"> The battery is not the "InfoLITHIUM" type.
Not enough battery	<ul style="list-style-type: none"> The battery level is too low to execute initialization or finalization.
	<ul style="list-style-type: none"> The battery level is low. Charge the battery pack (page 11). Depending on the conditions of use, the indicator may flash even though there is still 5 to 10 minutes of remaining battery time left.
Can not unfinalize	<ul style="list-style-type: none"> A CD-R or disc that has not been finalized is inserted.
Can not format	<ul style="list-style-type: none"> A CD-R is inserted.
Format error	<ul style="list-style-type: none"> A disc formatted with equipment other than your camera is inserted. Format again with your camera (page 39).
Turn the power off and on again	<ul style="list-style-type: none"> A problem with the lens caused an error.
	<ul style="list-style-type: none"> The amount of light is not sufficient, so you are not holding the camera steady enough. Use the flash, or mount the camera on a tripod or otherwise secure the camera in place.

Self-diagnosis display

– If a code starting with an alphabet letter appears

Your camera has a self-diagnosis display. This function displays the camera condition on the LCD screen with a combination of a letter and four numerical digits. If this occurs, check the following code chart and attempt the corresponding corrective actions. The last two digits (indicated by □□) will differ depending on the state of the camera.

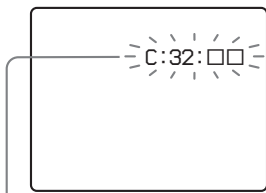

Self-diagnosis display

Code	Cause	Corrective action
C:32: □□	There is trouble with your camera's hardware.	• Turn the power off and on again (page 15).
C:13: □□	The camera cannot read or write data on the disc.	• Clean the disc when the disc is dirty (page 120).
	The inserted disc cannot be used with your camera, or the data is damaged.	• Insert a new disc (page 18).
E:61: □□ E:91: □□	A camera malfunction that you cannot reverse has occurred.	• Press the RESET button (page 98) located on the bottom of the camera, then turn on the power again.

If you are unable to solve the problem even after trying the corrective actions a few times, contact your Sony dealer or local authorized Sony service facility and inform them of the 5-digit code.

Number of images that can be saved or shooting time

In addition to setting the image size and image quality, you can also select various recording modes according to the purpose of shooting.

- The values for the number of images that can be saved and the shooting time may vary, depending on the shooting conditions.
- For normal shooting times and numbers of images that can be saved, see page 21.
- The numbers in the table indicate the number of images that can be recorded or the recordable time for the supplied CD-R disc.

Number of still images that can be saved

(Units: images)

Recording mode		Image size				
		5.0M	4.5M (3:2)	3.1M	1.2M	VGA
Normal	Standard	95	95	145	345	1285
	Fine	51	51	81	194	655
E-Mail	Standard	91	91	137	303	845
	Fine	50	50	79	180	518
TIFF	Standard	7	8	8	8	8
	Fine	7	8	7	8	8
Voice*	Standard	89	89	131	276	669
	Fine	49	49	77	170	446

* When recording sound for 5-second

Shooting time

(Units: images)

Recording mode	Image size				Image quality	
	640(VGA)	160 (Mail)	Mobile	Normal	Standard	Fine
MPEG Movie	5 min. 51 sec.	89 min. 11 sec.	–	–	–	–
Clip Motion*	–	–	1070	505*	–	–
Multi Burst**	–	–	–	–	345	194

* When recording 10 frames per Clip Motion file

** The image size is 1.2M.

Menu items

Menu items that can be modified differ depending on the position of the mode dial.





The screen shows only the items you can operate in each specific mode.

Factory settings are indicated with ■.

When the mode dial is set to

Item	Setting	Description
Mode (REC Mode)	TIFF Voice E-Mail Exp Brktg Burst 3 ■Normal	<ul style="list-style-type: none">– Records a uncompressed (TIFF) file in addition to the JPEG file (page 62).– Records an audio file (with a still image) in addition to the JPEG file (page 63).– Records a small-size (320×240) JPEG file in addition to the selected image size (page 62).– Records three images with the exposure value of each image slightly shifted (page 55).– Records three images in succession (page 61).– Records an image using the normal recording mode.

When the mode dial is set to P, S, A, M, or SCN







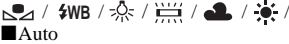

Item	Setting	Description
SCN		Sets the Scene Selection mode (page 64). (This setting can be made only in SCN mode.)
 (Metering Mode)	Spot / Center / ■Multi	Adjusts the exposure to the subject you are shooting (page 53).
WB (White Bal)	 / ■Auto	Sets the white balance (page 57).
ISO	400 / 200 / 100 / ■Auto	This selects the ISO sensitivity. Select a large number when shooting in dark locations or shooting a subject moving at high speed, or select a small number to obtain high image quality. (This setting cannot be made in SCN mode.)
 (P.Quality)	■Fine / Standard	Records images with fine/standard quality (page 43).

Item	Setting	Description
Mode (REC Mode)	TIFF Voice E-Mail Exp Brktg Burst 3 ■Normal	<ul style="list-style-type: none"> – Records a uncompressed (TIFF) file in addition to the JPEG file (page 62). – Records an audio file (with a still image) in addition to the JPEG file (page 63). – Records a small-size (320×240) JPEG file in addition to the selected image size (page 62). – Records three images with the exposure value of each image slightly shifted (page 55). – Records three images in succession (page 61). – Records an image using the normal recording mode.
± (Flash Level)	High / ■Normal / Low	Selects the amount of flash light (page 58).
PFX (P.Effect)	Solarize / Sepia / Neg. Art / ■Off	Sets the image special effects (page 65).
□ (Sharpness)	+ / ■Normal / –	Adjusts the sharpness of the image. The □ indicator appears (except when the setting is Normal.) (This setting cannot be made in SCN mode.)
⊕ (Saturation)	+ / ■Normal / –	Adjusts the saturation of the image. The ⊕ indicator appears (except when the setting is Normal.) (This setting cannot be made in SCN mode.)
● (Contrast)	+ / ■Normal / –	Adjusts the contrast of the image. The ● indicator appears (except when the setting is Normal.) (This setting cannot be made in SCN mode.)









When the mode dial is set to (when [Moving Image] is set to [MPEG Movie] in the SET UP settings)

Item	Setting	Description
▣ (Metering Mode)	Spot / Center / ■Multi	Adjusts the exposure to the subject you are shooting (page 53).
WB (White Bal)	 / ■Auto	Sets the white balance (page 57).
PFX (P.Effect)	Solarize / Sepia / Neg. Art / ■Off	Sets the image special effects (page 65).



When the mode dial is set to (when [Moving Image] is set to [Clip Motion] in the SET UP settings)

Item	Setting	Description
 (Metering Mode)	Spot / Center / <input checked="" type="checkbox"/> Multi	Adjusts the exposure to the subject you are shooting (page 53).
WB (White Bal)	 /  /  /  /  /  / <input checked="" type="checkbox"/> Auto	Sets the white balance (page 57).
 ± (Flash Level)	High / <input checked="" type="checkbox"/> Normal / Low	Selects the amount of flash light (page 58).
PFX (P.Effect)	Solarize / Sepia / Neg. Art / <input checked="" type="checkbox"/> Off	Sets the image special effects (page 65).

When the mode dial is set to (when [Moving Image] is set to [Multi Burst] in the SET UP settings)

Item	Setting	Description
 (Metering Mode)	Spot / Center / <input checked="" type="checkbox"/> Multi	Adjusts the exposure to the subject you are shooting (page 53).
WB (White Bal)	 /  /  /  /  /  / <input checked="" type="checkbox"/> Auto	Sets the white balance (page 57).
 (Interval)	1/7.5 / 1/15 / <input checked="" type="checkbox"/> 1/30 (NTSC) 1/6.3 / 1/12.5 / <input checked="" type="checkbox"/> 1/25 (PAL)	<ul style="list-style-type: none"> – Selects the Multi Burst shutter interval in NTSC mode. – Selects the Multi Burst shutter interval in PAL mode. • The shutter interval settings differ depending on the setting of the [Video Out] item in the SET UP settings (page 118).
 (P.Quality)	<input checked="" type="checkbox"/> Fine / Standard	Records images with fine/standard quality (page 43).
PFX (P.Effect)	Solarize / Sepia / Neg. Art / <input checked="" type="checkbox"/> Off	Sets the image special effects (page 65).

When the mode dial is set to

Item	Setting	Description
Folder	OK / Cancel	Selects the folder containing the image you want to play back (page 69).
Protect	—	Protects images against accidental erasure (page 75).
DPOF	—	Marks the print (DPOF) mark on still images you want to print (page 77).
Slide	Interval Image Repeat Start Cancel	<ul style="list-style-type: none"> – Sets the slide show interval (page 71). (Only in single-image mode.) <ul style="list-style-type: none"> ■ 5 sec / 10 sec / 30 sec / 1 min – Sets the range of the playback images. <ul style="list-style-type: none"> ■ Folder / All – Plays back images repeatedly. <ul style="list-style-type: none"> ■ On / Off – Starts the slide show. – Cancels the slide show.
Resize	5.0M / 3.1M / 1.2M / VGA / Cancel	Changes the recorded still image size (page 77). (Only in single-image mode.)
Rotate	 (counter clockwise) /  (clockwise) / OK / Cancel	Rotates the still image (page 72). (Only in single-image mode.)

SET UP items



Set the mode dial to SET UP. The SET UP screen appears.

Factory settings are indicated with ■.

(Camera 1)

Item	Setting	Description
Moving Image	■MPEG Movie / Clip Motion / Multi Burst	Selects the shooting mode for a movie (pages 80, 59 and 60).
AF Mode	Single / ■Monitor / Cont	Selects the focus operation mode (page 49).
Smart Zoom	■On / Off	Selects whether to use the smart zoom (page 25).
Date/Time	Day & Time / Date / ■Off	Selects whether to superimpose the date or time onto the image (page 31). The date and time are not inserted in movie (MPEG Movie), Clip Motion or Multi Burst mode. Also, the date and time appear only during playback, and do not appear during recording.
Red Eye Reduction	On / ■Off	Reduces the red-eye phenomenon when using a flash (page 28).
Hologram AF	■Auto / Off	Selects whether to emit hologram AF light. Used when it is difficult to focus on the subject in dark conditions (page 29).

(Camera 2)

Item	Setting	Description
Bracket Step	$\pm 1.0\text{EV}$ /  $\pm 0.7\text{EV}$ / $\pm 0.3\text{EV}$	Sets the exposure compensation value when recording three images with each exposure value shifted (page 55).
Conversion Lens	On /  Off	Set to [On] when using the VCL-MHG07 conversion lens (not supplied). At this time, the zoom or the focus preset function does not work. Also, note that the VAD-S70 adaptor ring needed to mount the conversion lens to your camera is not sold in some countries and regions.
Hot Shoe	On /  Off	Set to [On] when using a commercially available external flash (page 67).

When [Conversion Lens] is set to [On]:

- When the mode dial is set to A or M, you can only select aperture values of F4 or higher.
- The Zoom function is not available.
- The macro recording function activates automatically (the  indicator does not appear).

(Disc Tool 1)

Item	Setting	Description
Finalize	OK / Cancel	Finalizes a disc to allow viewing through a CD-ROM drive (page 85).
Format	OK / Cancel	Formats a CD-RW (page 39).
Initialize	OK / Cancel	Initializes a disc (page 19).
Unfinalize	OK / Cancel	Cancels the last executed finalization (page 86) (CD-RW only).

(Disc Tool 2)

Item	Setting	Description
File Number	■Series Reset	– Assigns numbers to files in sequence even if the disc is changed or the recording folder is changed. – Resets the file numbering and starts from 0001 each time the folder is changed. (When the recording folder contains a file, a number one higher than the largest number is assigned.)
Create REC. Folder	OK / Cancel	Creates a folder for recording images (page 44).
Change REC. Folder	OK / Cancel	Changes a folder for recording images (page 44).
Confirm B. Write	On / ■Off	Selects whether to confirm recording or deletion of the image before writing to the disc (page 66).

(Setup 1)

Item	Setting	Description
LCD Brightness	Bright / ■Normal / Dark	Selects the LCD brightness. This has no effect on the recorded images.
LCD Backlight	Bright / ■Normal	Selects the brightness of the LCD backlight. Selecting [Bright] makes the screen bright and easy to see when using the camera outdoors or in other bright locations, but also uses up the battery charge faster. Displayed only when using your camera with the battery pack.
Beep	Shutter ■On Off	– Turns on the shutter sound. (The shutter sound is heard when you press the shutter button.) – Turns on the beep/shutter sound when you press the control button/shutter button. – Turns off the beep/shutter sound.
Language	—	Displays the menu items, warnings and messages in selected language.
Clock Set	OK / Cancel	Sets the date and time (pages 16 and 41).

(Setup 2)

Item	Setting	Description
Video Out	NTSC PAL	– Sets the video output signal to NTSC mode (e.g., USA, Japan). – Sets the video output signal to PAL mode (e.g., Europe).

Precautions

On handling the camera

Do not carry the camera by the disc cover

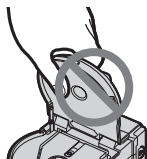

Do not touch the rotating disc

This may cause injury.

On cleaning the pickup lens

When the pickup lens becomes dirty and the camera cannot operate properly, clean the pickup lens using a commercially available blower.

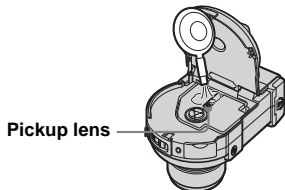

On pickup lens

Do not touch the pickup lens inside the disc cover. Also, do not open the disc cover except when inserting or removing a disc in order to keep dust out.

Do not leave the camera in the following places

- In extremely hot place, such as in a car parked in the sun. The camera body may become deformed or this may cause a malfunction.
- Under direct sunlight or near a heater. The camera body may become deformed or this may cause a malfunction.
- On rocking vibration
- Near strong magnetic place
- In sandy or dusty places, be careful not to let sand or dust get into the camera. This may cause the camera to malfunction, and in some cases this malfunction cannot be repaired.

On cleaning

Cleaning the LCD screen

Wipe the screen surface with an LCD cleaning kit (not supplied) to remove fingerprints, dust, etc.

Cleaning the DC plug

Clean the DC plug of the AC Adaptor with a dry cotton bud. Do not use the dirty plug. Use of the dirty plug may not properly charge the battery pack.

Cleaning the lens

Wipe the lens with a soft cloth to remove fingerprints, dust, etc.

Cleaning the camera surface

Clean the camera surface with a soft cloth slightly moistened with water, then wipe the surface with a dry cloth. Do not use the following as this may damage the finish or the casing.

- Thinner
- Benzine
- Alcohol
- Disposable cloth
- Volatile insecticide
- Contact with rubber or vinyl for a long time

Note on operating temperature

Your camera is designed for use between the temperatures of 0°C and 40°C (32° F and 104° F). Shooting in extremely cold or hot places that exceed this range is not recommended.

On moisture condensation

If the camera is brought directly from a cold to a warm location, or is placed in a very damp room, moisture may condense inside or outside the camera. This moisture condensation may cause a malfunction of the camera.

Moisture condensation occurs easily when:

- The camera is brought from a cold location such as a ski slope into a warmly heated room.
- The camera is taken from an air-conditioned room or car interior to the hot outdoors, etc.

How to prevent moisture condensation

When bringing the camera from a cold place to a warm place, seal the camera in a plastic bag and allow it to adapt to conditions at the new location over a period of time (about an hour).

If moisture condensation occurs

Turn off the camera and wait about an hour for the moisture to evaporate. Note that if you attempt to shoot with moisture remaining inside the lens, you will be unable to record clear images.

On internal rechargeable button battery

This camera has an internal rechargeable button battery for maintaining the date and time and other settings regardless of whether the power is on or off.

This rechargeable button battery is continually charged as long as you are using the camera. However, if you use the camera for only short periods it discharges gradually, and if you do not use the camera at all for about one month it becomes completely discharged. In this case, be sure to charge this rechargeable button battery before using the camera.

However, even if this rechargeable button battery is not charged, you can still use the camera as long as you do not record the date and time.

Charging method

Connect the camera to a wall outlet (mains) using the AC Adaptor, or install a charged battery pack, and leave the camera for 24 hours or more with the power off.

On discs

Cleaning the disc

- Do not clean a disc using a cleaner before shooting. Use a commercially available blower to remove dust.
- If fingerprints, dust, droplets of water, or oil make the recordable side (the reverse of the printed side) of a disc dirty, the camera may not properly record images on the disc. Be sure to handle discs with care.
- Do not scratch both sides of a disc.
- If a disc does become dirty, wipe it in a straight line from center to edge with a soft dry cloth or a soft cloth lightly moistened with ethyl alcohol or other mild detergent. You can also use a commercially available CD cleaner.

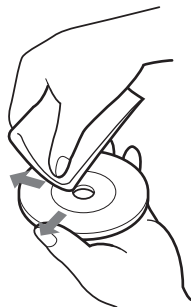

- Do not use any solvent (benzine, thinner, static protection product, record cleaner, etc.) to clean a disc.

Notes

- Do not remove the disc while reading or writing data.
- Data may be damaged if:
 - You remove the disc or shake the camera while reading or writing data.
 - You turn off your camera while reading or writing data.
 - You use the camera in a location subject to the effects of static electricity or noise.
- Do not attach any material on the surface of a disc. This causes a nonuniform rotating speed, which may cause the camera to malfunction.
- You can write only on the label surface of a disc. Write using only an oil-based felt-tip marker and do not touch the ink until dry. Do not heat the disc or use a sharp-pointed tool, such as a ballpoint pen.
- Hold the disc at the edges while supporting the center hole lightly. Do not touch the recordable side (the reverse of the printed side) of a disc.

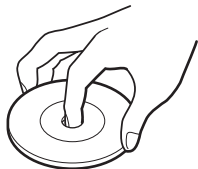

- When you carry or store a disc, put it in its case.
- Do not strike, bend, drop or rub the edge of a disc.

- Do not store a disc in the following locations:
 - In dusty or dirty places
 - Exposed to direct sunlight
 - Near heaters
 - In damp places
- If you attempt to play back a disc on which no images have been recorded using a CD-ROM drive, the CD-ROM drive may malfunction or the disc may be scratched.

On “InfoLITHIUM” battery pack



What is the “InfoLITHIUM” battery pack?

The “InfoLITHIUM” battery pack is a lithium-ion battery pack that has functions for communicating information related to operating conditions between your camera and the AC Adaptor.

The “InfoLITHIUM” battery pack calculates the power consumption according to the operating conditions of your camera, and displays the remaining battery time in minutes.

Charging the battery pack

We recommend charging the battery pack in an ambient temperature of between 10°C to 30°C (50°F to 86°F). You may not be able to efficiently charge the battery pack outside of this temperature range.

Effective use of the battery pack

- Battery performance decreases in low-temperature surroundings. So, the time that the battery pack can be used is shorter in cold places. We recommend the following to ensure longer battery pack use:
 - Put the battery pack in a pocket close to your body to warm it up, and insert it in your camera immediately before you start shooting.
- Frequently operating the zoom or flash wears out the battery charge faster.
- We recommend having spare battery packs handy for two or three times the expected shooting time, and making trial shots before taking the actual shots.
- Do not expose the battery pack to water. The battery pack is not water-resistant.

Remaining battery time indicator

The power may go off although the battery remaining indicator shows there is enough power to operate. Use the battery pack up and charge the battery pack fully again so that the indication on the battery remaining indicator is correct. Note, however, that the correct battery indication sometimes will not be restored if the camera is used in high temperatures for a long time or left in a fully charged state, or the battery pack is frequently used.

How to store the battery pack

- If the battery pack is not to be used for a long time, do the following procedure once per year to maintain proper function.
 - 1 Fully charge the battery.
 - 2 Discharge on your camera.
 - 3 Remove the battery from your camera and store it in a dry, cool place.

Battery life

- The battery life is limited. Battery capacity decreases little by little as you use it more and more, and as time passes. When the battery operating time is shortened considerably, a probable cause is that the battery pack has reached the end of its life. Buy a new battery pack.
- The battery life varies according to how it is stored and the operating conditions and environment for each battery pack.

Specifications

■ Camera

[System]

Image device

9.04 mm (1/1.8 type) color CCD
Primary color filter

Total pixels number of camera

Approx. 5 255 000 pixels

Effective pixels number of camera

Approx. 5 090 000 pixels

Lens

3× zoom lens
f = 7.0 – 21.0 mm (9/32 – 27/32 inches) (34 – 102 mm (1 3/8 – 4 1/8 inches) when converted to a 35 mm still camera)
F2.0 – 2.5

Exposure control

Automatic exposure, Shutter speed priority, Aperture priority, Manual exposure, Scene selection (6 modes)

White balance

Automatic, Daylight, Cloudy, Fluorescent, Incandescent, Flash, One-push

File format (DCF compliant)

Still images: Exif Ver. 2.2 JPEG compliant, GIF (for Clip Motion), TIFF, DPOF compatible
Audio with still image: MPEG1 compliant (Monaural)
Movies: MPEG1 compliant (Monaural)

Recording media

8 cm CD-R/CD-RW

Flash

Recommended distance (ISO set to Auto): 0.5 m to 5.0 m (19 3/4 inches to 196 7/8 inches)

[Drive]

Readout

Non-contact optical readout (using semiconductor laser)

Laser

Wavelength: 779 to 789 nm
Maximum output: 23 mW

[Input and Output connectors]

A/V OUT (MONO) (Monaural)

Minijack

Video: 1 V_{p-p}, 75 Ω unbalanced, sync negative

Audio: 327 mV (at a 47 kΩ load)
Output impedance 2.2 kΩ

ACC jack

Mini-minijack (ø 2.5 mm)

USB jack

mini-B

[LCD screen]

LCD panel

6.2 cm (2.5 type) TFT drive

Total number of dots

123 200 (560×220) dots

[General]

Used battery pack

NP-FM50

Power requirements

7.2 V

Power consumption (during shooting with LCD backlight on)

3.0 W

Operating temperature

0°C to 40°C (32°F to 104°F)

Storage temperature

-20°C to +60°C (4°F to +140°F)

Dimensions

138.5×95.7×103.1 mm
(5 1/2×3 7/8×4 1/8 inches)
(W/H/D, excluding maximum protrusions)

Mass

Approx. 606 g (1 lb 5 oz) (including battery pack NP-FM50, disc, and lens cap)

Built-in microphone

Electret condenser microphone

Built-in speaker

Dynamic speaker

Exif Print

Compatible

PRINT Image Matching II

Compatible

■ AC-L15A/L15B AC Adaptor

Power requirements

100 – 240 V AC, 50/60 Hz

Current consumption

0.35 – 0.18 A

Power consumption

18 W

Output rating

8.4 V DC*

*See the label on the AC Adaptor for other specifications.

Operating temperature

0°C to 40°C (32°F to 104°F)

Storage temperature

-20°C to +60°C (-4°F to +140°F)

Dimensions (approx.)

56×31×100 mm

(2 1/4×1 1/4×4 inches) (w/h/d)

excluding projecting parts

Mass (approx.)

190 g (6.7 oz) excluding power cord
(mains lead)

■ NP-FM50 battery pack

Used battery

Lithium-ion battery

Maximum voltage

DC 8.4 V

Nominal voltage

DC 7.2 V

Capacity

8.5 Wh (1 180 mAh)

■ Accessories

- AC Adaptor (1)
- Power cord (mains lead) (1)
- USB cable (1)
- NP-FM50 battery pack (1)
- A/V connecting cable (1)
- 8 cm CD adaptor (1)
- Mavica disc (2) (CD-R (1), CD-RW (1))
- Shoulder strap (1)
- Lens cap (1)
- Lens cap strap (1)
- CD-ROM (SPVD-010) (1)
- Operating instructions (1)

Design and specifications are subject to change without notice.

The LCD screen

When shooting still images

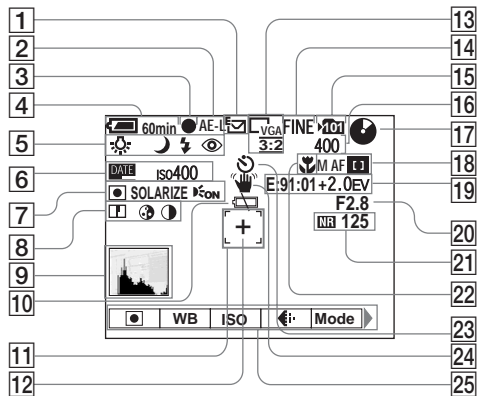

- 1 Recording mode indicator (59-63)
- 2 AE LOCK indicator (55)
- 3 AE/AF lock indicator (22)
- 4 Battery remaining indicator (12)
- 5 White balance indicator (57)/
Mode dial indicator/
Flash mode indicator (27)/
Red-eye reduction indicator (28)/
Conversion lens indicator (117)
- 6 Date/time indicator (31)/
ISO number indicator (112)

- 7 Metering modes indicator (53)/
Picture effect indicator (65)/
Hologram AF indicator (29)
- 8 Sharpness indicator (113)/
Saturation indicator (113)/
Contrast indicator (113)
- 9 Histogram indicator (52)
- 10 Low battery warning indicator
(108)
- 11 AF range finder frame (48)
- 12 Spot metering cross hair (54)
- 13 Image size indicator (20)
- 14 Image quality indicator (43)

- 15 Recording folder indicator (43)
- 16 Remaining number of recordable
images indicator (21)
- 17 Remaining disc capacity
indicator
- 18 AF mode (49)/AF range finder
frame indicator (48)/Focus
preset value (50)
- 19 Self-diagnosis display (109)/EV
level indicator (51)
- 20 Aperture value indicator (45)
- 21 NR slow shutter indicator (46)/
Shutter speed indicator (45)
- 22 Macro indicator (26)
- 23 Self-timer indicator (27)
- 24 Light amount warning indicator
- 25 Menu/Guide menu (41)

- Pressing MENU switches the menu on/off.

Page numbers in parentheses indicate the location of additional important information.

When shooting movies

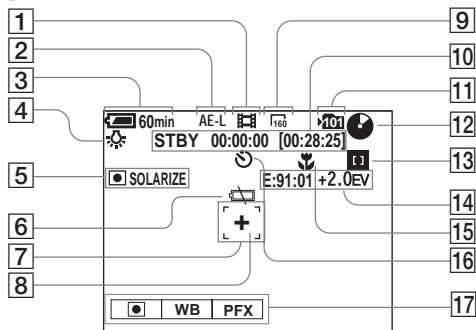

- | | |
|--|---|
| 1 Recording mode indicator (80) | 11 Recording folder indicator (43) |
| 2 AE LOCK indicator (55) | 12 Remaining disc capacity indicator |
| 3 Battery remaining indicator (12) | 13 AF range finder frame indicator (48)/Focus preset value (50) |
| 4 White balance indicator (57) | 14 Self-diagnosis display (109)/EV level indicator (51) |
| 5 Metering modes indicator (53)/ Picture effect indicator (65) | 15 Macro indicator (26) |
| 6 Low battery warning indicator (108) | 16 Self-timer indicator (27) |
| 7 AF range finder frame (48) | 17 Menu/Guide menu (41) |
| 8 Spot metering cross hair (54) | |
| 9 Image size indicator (80) | |
| 10 Recording time [maximum recordable time] indicator/ Conversion lens indicator (117) | |

- Pressing MENU switches the menu on/off.

When playing back still images

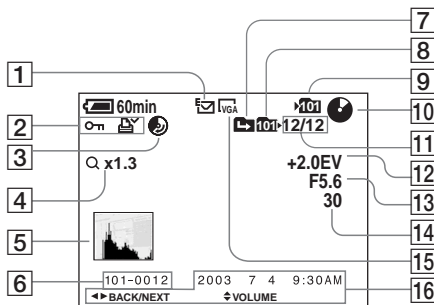

- | | |
|--|--|
| 1 Recording mode indicator (59-63) | 13 Aperture value indicator (45) |
| 2 Protect indicator (75)/
Print (DPOF) mark indicator (77)/
Volume indicator (63) | 14 Shutter speed indicator (45) |
| 3 Remaining space recovery
indicator (36) | 15 Image size indicator (20) |
| 4 Zoom scaling indicator (70)/
Jog playback indicator (73) | 16 Recording date of the playback
image (31)/Menu/Guide menu
(41) |
| 5 Histogram indicator (52) | |
| 6 Folder-file number | |
| 7 Change folder indicator | |
| 8 Playback folder indicator (69) | |
| 9 Recording folder indicator | |
| 10 Remaining disc capacity
indicator | |
| 11 Image number/Number of
images recorded in selected
folder | |
| 12 EV level indicator (51) | |

Page numbers in parentheses indicate the location of additional important information.

When playing back moving images

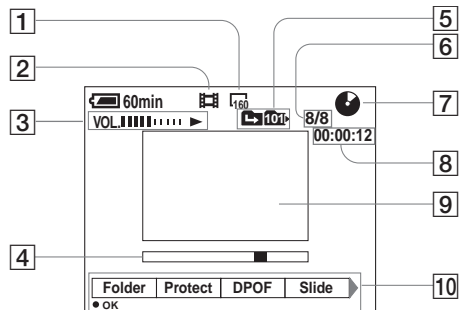

- 1** Image size indicator (81)
- 2** Recording mode indicator (81)
- 3** Volume indicator (81)/Playback indicator (81)/Remaining space recovery indicator (36)
- 4** Playback bar (81)
- 5** Change folder indicator/ Playback folder indicator (69)
- 6** Image number/Number of images recorded in selected folder
- 7** Remaining disc capacity indicator
- 8** Counter (81)
- 9** Playback image (81)
- 10** Menu/Guide menu (41)

Page numbers in parentheses indicate the location of additional important information.

Index

A

AC Adaptor	11, 14
Access lamp	18
Advanced accessory shoe	9, 67
AE/AF lock	50
AE/AF lock indicator	22
AF lock	50
AF Mode	49
AF range finder frame	48
Aperture priority mode	47
Auto adjustment mode	22
Auto Focus	24, 47
Auto power-off function	15
A/V connecting cable	34

B

Battery pack	
battery life	13, 122
charging	11, 121
charging time	12
remaining indicator	12, 122
Beep/shutter sound	118
Bracket	55
Brightness	
image	51, 55
LCD screen	118
Burst	61

C

Changing the recording folder	44
Charging	
battery pack	11, 121
charging time	12
Cleaning	119, 120
Clip Motion	59
Clock set	16
Computer	
copying images	94, 97
ImageMixer	92
PTP Manager	91
Confirm before write	66
Contrast	113
Control button	10, 15, 41
Conversion lens	117
Copying images	94, 97
Creating a new folder	44

D

DC plug	11, 14
Deleting images	36, 82
Disc	
cleaning	120
finalizing	85
formatting	39
initializing	19
inserting	18
number of images that can be saved or shooting time	110
unfinalizing	86
DPOF	77

E

Editing still images	
Print (DPOF) mark	77
Protect	75
Resize	77
E-mail	62
Enlarging an image	70
EV adjustment	51
Exposure bracket	55
External power source	14

F

File	
file names	90
image file storage destinations	89
Flash	
external flash	67
Flash Level	58
Red-eye reduction	28
selecting a flash mode	27
Focusing	
AF lock	50
auto focus method	47
Continuous AF	49
focus preset	50
Monitoring AF	49
Multipoint AF	48
Selected frame priority AF	48
shooting (using auto adjustment mode)	22
Single AF	49
Spot AF	48

Folder	
changing the recording folder	44
creating a new folder	44
playback folder	69
Recording folder	44
Formatting a CD-RW	39
G	
GIF	59, 90
H	
Histogram	52
Hologram AF	29
Hot shoe	117
I	
Image	
copying images to your computer	94, 97
file names	90
image file storage destinations	89
image quality	21
image size	20, 110
“InfoLITHIUM” battery pack	121
Installation	
ImageMixer	92
PTP Manager	91
ISO	112
J	
Jog dial	42
Jog playback	73
JPG	90

L	
LCD screen	
brightness	118
screen display	125, 126, 127, 128
M	
Manual exposure mode	47
Menu settings	41, 112
Metering mode	
center-weighted metering	53
multi-pattern metering	53
spot metering	54
Mode dial	16, 23
Moisture condensation	120
Movie	
deleting movies	82
number of images that can be saved or	
shooting time	13, 111
shooting movies	80
viewing images on your computer	84
viewing movies on the LCD screen	81
MPEG Movie	80
MPG	90
Multi Burst	60
N	
NR slow shutter	46
NTSC system	35, 118

P	
PAL system	35, 118
Picture effect	65
Power	
AC Adaptor	14
battery pack	11
on/off	15
Precautions	119
Print (DPOF) mark	77
Protect	75
Q	
Quick Review	24
R	
Red-eye reduction	28
RESET button	98
Resize	77
Rotate	72
S	
Saturation	113
Scene Selection	
Beach mode	65
Landscape mode	64
Portrait mode	64
Snow mode	64
Twilight mode	64
Twilight portrait mode	64
Self-diagnosis display	109
Self-timer	27

Setting	
date and time	16
image size	20, 110
menu items	41, 112
SET UP items	41, 116
Sharpness	113
Shooting mode	
auto adjustment mode	22
Bracket	55
Burst	61
Clip Motion	59
E-mail	62
movie	80
Multi Burst	60
TIFF	62
Voice	63
Shutter speed priority mode	46
Slide show	71
Smart zoom	25
Still image shooting	
auto adjustment mode	22
EV adjustment	51
image size	20, 110
metering mode	53
number of images that can be saved or shooting time	21, 110
picture effect	65
Scene Selection	64
shooting close-ups (Macro)	26
superimposing the date and time	31
using the flash	27
using the self-timer	27
using the zoom feature	25
White Balance	57

Still image viewing	
delete	36
index screen	33
playback zoom	70
rotate	72
single image screen	32
slide show	71
viewing images on a TV screen	34
viewing images on the LCD screen	32
viewing images on your computer	84
Superimposing the date and time	31

T

TIFF	62
Trimming	71
TV color system	35

U

Unfinalizing a disc	86
USB	91, 93, 97
Using your camera abroad	14

V

Video CD	96
Viewing images on the LCD screen	32, 81
Viewing images on your computer	84
Voice	63

W

Warnings and messages	107
White Balance	57

Z

Zoom	
playback zoom	70
smart zoom	25
using the zoom feature	25

308183714



Printed on 100% recycled paper
using VOC (Volatile Organic
Compound)-free vegetable oil
based ink.

<http://www.sony.net/>
Sony Corporation Printed in Japan

Additional information on this product and answers to frequently
asked questions can be found at our Customer Support Website.