

Pioneer *sound.vision.soul*

DIGITAL MEDIA PLAYER

DMP-555



Operating Instructions

WARNING: THE APPARATUS IS NOT WATERPROOFS, TO PREVENT FIRE OR SHOCK HAZARD, DO NOT EXPOSE THIS APPLIANCE TO RAIN OR MOISTURE AND DO NOT PUT ANY WATER SOURCE NEAR THIS APPARATUS, SUCH AS VASE, FLOWER POT, COSMETICS CONTAINER AND MEDICINE BOTTLE ETC.

H001AEn

IMPORTANT



The lightning flash with arrowhead symbol, within an equilateral triangle, is intended to alert the user to the presence of uninsulated "dangerous voltage" within the product's enclosure that may be of sufficient magnitude to constitute a risk of electric shock to persons.



CAUTION:
TO PREVENT THE RISK OF ELECTRIC SHOCK, DO NOT REMOVE COVER (OR BACK). NO USER-SERVICEABLE PARTS INSIDE. REFER SERVICING TO QUALIFIED SERVICE PERSONNEL.



The exclamation point within an equilateral triangle is intended to alert the user to the presence of important operating and maintenance (servicing) instructions in the literature accompanying the appliance.

NOTE: THE NO USER-SERVICEABLE PARTS COMPARTMENT WARNING IS LOCATED ON THE APPLIANCE BOTTOM.

IMPORTANT SAFETY INSTRUCTIONS

H003 En

READ INSTRUCTIONS — All the safety and operating instructions should be read before the product is operated.

RETAIN INSTRUCTIONS — The safety and operating instructions should be retained for future reference.

HEED WARNINGS — All warnings on the product and in the operating instructions should be adhered to.

FOLLOW INSTRUCTIONS — All operating and use instructions should be followed.

CLEANING — Unplug this product from the wall outlet before cleaning. The product should be cleaned only with a polishing cloth or a soft dry cloth. Never clean with furniture wax, benzene, insecticides or other volatile liquids since they may corrode the cabinet.

ATTACHMENTS — Do not use attachments not recommended by the product manufacturer as they may cause hazards.

WATER AND MOISTURE — Do not use this product near water — for example, near a bathtub, wash bowl, kitchen sink, or laundry tub; in a wet basement; or near a swimming pool; and the like.

ACCESSORIES — Do not place this product on an unstable cart, stand, tripod, bracket, or table. The product may fall, causing serious injury to a child or adult, and serious damage to the product. Use only with a cart, stand, tripod, bracket, or table recommended by the manufacturer, or sold with the product. Any mounting of the product should follow the manufacturer's instructions, and should use a mounting accessory recommended by the manufacturer.

CART — A product and cart combination should be moved with care. Quick stops, excessive force, and uneven surfaces may cause the product and cart combination to overturn.



VENTILATION — Slots and openings in the cabinet are provided for ventilation and to ensure reliable operation of the product and to protect it from overheating, and these openings must not be blocked or covered. The openings should never be blocked by placing the product on a bed, sofa, rug, or other similar surface. This product should not be placed in a built-in installation such as a bookcase or rack unless proper ventilation is provided or the manufacturer's instructions have been adhered to.

POWER SOURCES — This product should be operated only from the type of power source indicated on the marking label. If you are not sure of the type of power supply to your home, consult your product dealer or local power company.

LOCATION — The appliance should be installed in a stable location.

NONUSE PERIODS — The power cord of the appliance should be unplugged from the outlet when left unused for a long period of time.

GROUNDING OR POLARIZATION

- If this product is equipped with a polarized alternating current line plug (a plug having one blade wider than the other), it will fit into the outlet only one way. This is a safety feature. If you are unable to insert the plug fully into the outlet, try reversing the plug. If the plug should still fail to fit, contact your electrician to replace your obsolete outlet. Do not defeat the safety purpose of the polarized plug.

- If this product is equipped with a three-wire grounding type plug, a plug having a third (grounding) pin, it will only fit into a grounding type power outlet. This is a safety feature. If you are unable to insert the plug into the outlet, contact your electrician to replace your obsolete outlet. Do not defeat the safety purpose of the grounding type plug.

POWER-CORD PROTECTION — Power-supply cords should be routed so that they are not likely to be walked on or pinched by items placed upon or against them, paying particular attention to cords at plugs, convenience receptacles, and the point where they exit from the product.

OUTDOOR ANTENNA GROUNDING — If an outside antenna or cable system is connected to the product, be sure the antenna or cable system is grounded so as to provide some protection against voltage surges and built-up static charges. Article 810 of the National Electrical Code, ANSI/NFPA 70, provides information with regard to proper grounding of the mast and supporting structure, grounding of the lead-in wire to an antenna discharge unit, size of grounding conductors, location of antenna-discharge unit, connection to grounding electrodes, and requirements for the grounding electrode. See Figure A.

LIGHTNING — For added protection for this product during a lightning storm, or when it is left unattended and unused for long periods of time, unplug it from the wall outlet and disconnect the antenna or cable system. This will prevent damage to the product due to lightning and power-line surges.

POWER LINES — An outside antenna system should not be located in the vicinity of overhead power lines or other electric light or power circuits, or where it can fall into such power lines or circuits. When installing an outside antenna system, extreme care should be taken to keep from touching such power lines or circuits as contact with them might be fatal.

OVERLOADING — Do not overload wall outlets, extension cords, or integral convenience receptacles as this can result in a risk of fire or electric shock.

OBJECT AND LIQUID ENTRY — Never push objects of any kind into this product through openings as they may touch dangerous voltage points or short-out parts that could result in a fire or electric shock. Never spill liquid of any kind on the product.

SERVICING — Do not attempt to service this product yourself as opening or removing covers may expose you to dangerous voltage or other hazards. Refer all servicing to qualified service personnel.

DAMAGE REQUIRING SERVICE — Unplug this product from the wall outlet and refer servicing to qualified service personnel under the following conditions:

- When the power-supply cord or plug is damaged.
- If liquid has been spilled, or objects have fallen into the product.
- If the product has been exposed to rain or water.
- If the product does not operate normally by following the operating instructions. Adjust only those controls that are covered by the operating instructions as an improper adjustment of other controls may result in damage and will often require extensive work by a qualified technician to restore the product to its normal operation.
- If the product has been dropped or damaged in any way.
- When the product exhibits a distinct change in performance — this indicates a need for service.

REPLACEMENT PARTS — When replacement parts are required, be sure the service technician has used replacement parts specified by the manufacturer or have the same characteristics as the original part. Unauthorized substitutions may result in fire, electric shock, or other hazards.

SAFETY CHECK — Upon completion of any service or repairs to this product, ask the service technician to perform safety checks to determine that the product is in proper operating condition.

WALL OR CEILING MOUNTING — The product should not be mounted to a wall or ceiling.

HEAT — The product should be situated away from heat sources such as radiators, heat registers, stoves, or other products (including amplifiers) that produce heat.

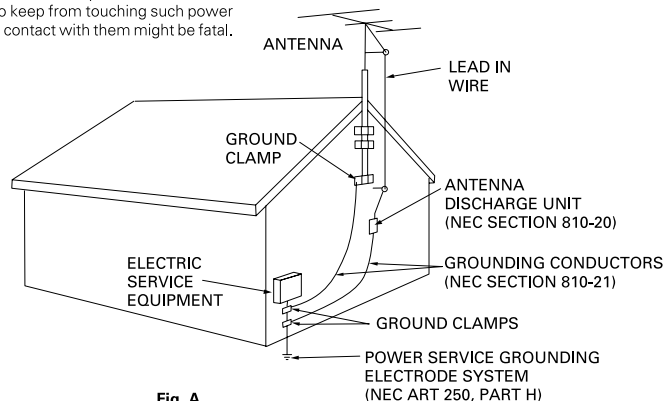

Fig. A

NEC — NATIONAL ELECTRICAL CODE

[For Canadian model]

This Class B digital apparatus complies with Canadian ICES-003.

[Pour le modèle Canadien]

Cet appareil numérique de la classe B est conforme à la norme NMB-003 du Canada.

H009 2L

[For U.S. model]**IMPORTANT NOTICE**

H006AEn

The serial number for this equipment is located in the rear panel. Please write this serial number on your enclosed warranty card and keep it in a secure area. This is for your security.

[For Canadian model]

CAUTION: TO PREVENT ELECTRIC SHOCK, DO NOT USE THIS (POLARIZED) PLUG WITH AN EXTENSION CORD, RECEPTACLE OR OTHER OUTLET UNLESS THE BLADES CAN BE FULLY INSERTED TO PREVENT BLADE EXPOSURE.

ATTENTION: POUR PREVENIR LES CHOCS ELECTRIQUES NE PAS UTILISER CETTE FICHE POLARISEE AVEC UN PROLONGATEUR UNE PRISE DE COURANT OU UNE AUTRE SORTIE DE COURANT, SAUF SI LES LAMES PEUVENT ETRE INSEREES A FOND SANS EN LAISSER AUCUNE PARTIE A DECOUVERT.

H007A2L

CAUTION:

This product satisfies FCC regulations when shielded cables (with Ferrite-cores attached) and connectors are used to connect the unit to other equipment. To prevent electromagnetic interference with electric appliances such as radios and televisions, use shielded cables (with Ferrite-cores attached) and connectors for connections.

H037 En

POWER-CORD CAUTION

S002 En

Handle the power cord by the plug. Do not pull out the plug by tugging the cord and never touch the power cord when your hands are wet as this could cause a short circuit or electric shock. Do not place the unit, a piece of furniture, etc., on the power cord, or pinch the cord. Never make a knot in the cord or tie it with other cords. The power cords should be routed such that they are not likely to be stepped on. A damaged power cord can cause a fire or give you an electrical shock. Check the power cord once in a while. When you find it damaged, ask your nearest PIONEER authorized service center or your dealer for a replacement.

NOTE: This equipment has been tested and found to comply with the limits for a Class B digital device, pursuant to Part 15 of the FCC Rules. These limits are designed to provide reasonable protection against harmful interference in a residential installation. This equipment generates, uses, and can radiate radio frequency energy and, if not installed and used in accordance with the instructions, may cause harmful interference to radio communications. However, there is no guarantee that interference will not occur in a particular installation. If this equipment does cause harmful interference to radio or television reception, which can be determined by turning the equipment off and on, the user is encouraged to try to correct the interference by one or more of the following measures:

- Reorient or relocate the receiving antenna.
- Increase the separation between the equipment and receiver.
- Connect the equipment into an outlet on a circuit different from that to which the receiver is connected.
- Consult the dealer or an experienced radio/TV technician for help.

H010 En

Information to User

H011 En

Alteration or modifications carried out without appropriate authorization may invalidate the user's right to operate the equipment.

CAUTION : USE OF CONTROLS OR ADJUSTMENTS OR PERFORMANCE OF PROCEDURES OTHER THAN THOSE SPECIFIED HEREIN MAY RESULT IN HAZARDOUS RADIATION EXPOSURE.

CAUTION : THE USE OF OPTICAL INSTRUMENTS WITH THIS PRODUCT WILL INCREASE EYE HAZARD.

H013 En

Thank you for buying this Pioneer product.

Please read through these operating instructions so you will know how to operate your model properly. After you have finished reading the instructions, put them away in a safe place for future reference.

In some countries or regions, the shape of the power plug and power outlet may sometimes differ from that shown in the explanatory drawings. However the method of connecting and operating the unit is the same.

K015 En

CONTENTS

CAUTIONS REGARDING HANDLING	4
FEATURES	6
CONNECTIONS	7
PANEL FACILITIES	10
DISC AND MEMORY CARD LOADING/UNLOADING	12
DJ PLAYER OPERATION	13
Auto Cueing	13
To Begin Playback	13
Stopping Playback	13
To Pause Play	13
Folder Search	13
To Skip To Other Tracks	14
Fast-Forward / Fast-Reverse	14
Setting a Cue Point	14
Changing Playback Speed	15
Applying Master Tempo	15
Jog Dial Function	15
ADVANCED OPERATIONS	16
Scratch Play	16
Loop Play	16
Isolator Function	17
Fader Start Playback	17
Relay Play Using Two Players	17
CARD MIXING (dual mode)	18
Card Mix Output Settings	18
Card Mix Playback	18
COMPUTER-LINKED OPERATIONS	20
TROUBLESHOOTING	21
Error Message Display	22
SPECIFICATIONS	23

BEFORE OPERATIONS

CAUTIONS REGARDING HANDLING

Location

Install the player in a well-ventilated location where it will not be exposed to high temperatures or humidity.

Do not install the player in a location which is exposed to direct sunlight, or near stoves or radiators. Excessive heat can adversely affect the cabinet and internal components. Installation of the player in a damp or dusty environment may also result in a malfunction and can be hazardous. Avoid installation near cookers etc., where the player may be exposed to oily smoke, steam or heat.

Installation Guidelines

- Placing and using the compact disc player for long periods on heat-generating sources such as amplifiers or near spotlights, etc. will affect product performance. Avoid placing the player on heat-generating sources.
- Install this compact disc player as far as possible away from tuners and TV sets. A compact disc player installed in close proximity to such equipment may cause noise or degradation of the picture.
- Noise may be noticeable when an indoor antenna is used. In such cases, make use of an outdoor antenna or turn off power to the compact disc player.
- When the unit is used in a loud-sound environment, e.g., near a speaker, sound skip may occur. Install the unit away from the speaker or reduce the listening volume.
- Place this unit on a level surface and a stable platform.
- Be sure the player, including its audio and power supply cords, does not touch vibrating materials. Any cause of vibration other than the insulators may cause the disc to skip. Take special care when using the player while it is installed in a carrying case.

- **Please be sure to leave a space to allow for heat radiation.**

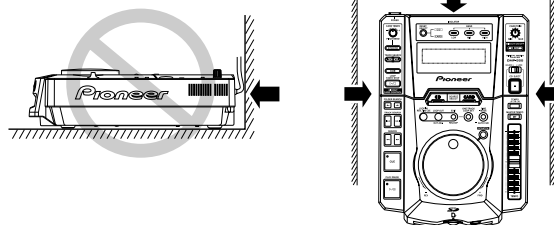

Do not place on or against vibrating materials!

Cleaning the Player

To clean the PLAYER wipe with a polishing or a soft, dry cloth. For stubborn dirt, moisten a soft cloth with a weak solution of neutral detergent (diluted in five to six parts water), wring the cloth well, and wipe away the dirt. Use a dry cloth to wipe the surface dry. Do not use volatile liquids such as benzene or thinner which will damage the unit.

Cleaning the Jog Dial

To clean the Jog dial wipe with a polishing or a soft, dry cloth. For stubborn dirt, moisten a soft cloth with a weak solution of neutral detergent (diluted in five to six parts water), wring the cloth well, and wipe away the dirt. Use a dry cloth to wipe the surface dry. Applying alcohol, paint thinner, benzene, insecticides, or other stringent substances to the Jog dial may cause the markings or finishing of the dial to peel or become discolored, and the use of any such substances should accordingly be avoided.

CD Lens Cleaner

The player's pickup lens should not become dirty in normal use. If for some reason, the lens becomes soiled and malfunctions, contact your nearest PIONEER authorized service center. Lens cleaners for CD players are commercially available, but special care should be exercised in their use as some may cause damage to the lens.

Storing Discs

- Discs are made of the same kinds of plastic used for conventional analog audio records. Be careful not to allow discs to warp. Always store discs in their cases vertically, avoiding locations with high heat, humidity, or extremely low temperatures. Avoid leaving discs in cars; the interior of a car in direct sunlight can become extremely hot.
- Always read and abide by the precautionary notes listed on disc labels.

Condensation

When this unit is brought into a warm room from previously cold surroundings or when the room temperature rises sharply, condensation may form inside the unit and impair its performance. In such cases, allow the unit to stand for about an hour or raise the room temperature gradually.

Cleaning and Handling Compact Discs

- The presence of fingerprints or smudges on the surface of the disc will not directly affect the recorded signals, but, depending on the degree of contamination, the brightness of the light reflected from the signal surfaces may be reduced causing degradation of sound quality. Always keep your discs clean by wiping them gently with a soft cloth from the inner edge toward the outer edge.



- If a disc becomes very dirty, dampen a soft cloth with water, (be sure to wring it out well) and wipe the away dirt gently. Remove any water drops with another soft, dry cloth.
- Do not use record cleaning sprays or anti-static agents on discs. Never clean discs with benzene, thinner, or other volatile solvents or damage to the disc surface may result.

- With this player, use only those discs which display the mark shown right (Optical audio digital discs).
- SACD hybrid discs cannot be played.



- When holding discs, do not touch their signal surfaces. Hold by the edges, or by one edge and the center hole.
- Do not affix gummed labels or tape to the disc surface. Also, do not scratch or damage the label.
- Discs rotate at high speeds inside the player. Do not use damaged, cracked or warped discs.



Do not play a CD with a special shape

Do not play a CD having other shape than a circular disc, such as heart shaped disc. Otherwise malfunction may occur.



FORCED DISC EJECTION

If the eject button does not function or the disc cannot be removed, pushing the pin provided into the forced ejection hole on the front panel will enable the disc to be removed.

When performing forced ejection, be sure to follow the precautions below.

- ① Be sure to turn OFF the power of the player, and check that the disc has stopped rotating. It takes about 60 seconds for the disc to stop rotating after the power has been turned OFF.

If forced ejection is performed while the disc is rotating;

- As the disc will be ejected outside the player rotating, it may hit your finger and cause injuries.
- As the disc will be rotating with the clamp unstable, it may be scratched.

For the above reasons, never attempt to eject the disc forcibly while it is rotating.

- ② Always use the pin provided (Do not use other objects). **The provided pin is found in a groove in the bottom surface of the player.**

When the provided forced eject pin is inserted fully into the forced eject hole on the front panel, the loaded disc is ejected about 5-10 mm from the loading slot, making it possible to remove it by hand.

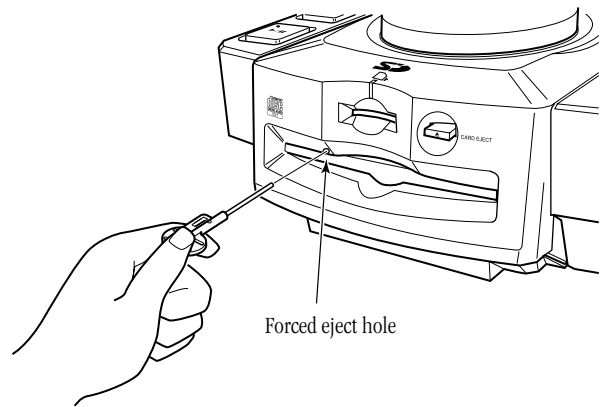

Forced eject hole

FEATURES

This component is a digital media player designed to play both compact discs and solid-state memory cards, and equipped with a “card mix” (dual mode) function, thus providing the features and operational convenience demanded by professional DJs in clubs and disco environments.

JOG DIAL

The large 100 mm diameter Jog dial enables better handling than an analog turntable.

● SCRATCH PLAY

When the jog dial is rotated in the SCRATCH mode, playback will occur in response to the direction and speed of jog-dial rotation.

● PITCH BEND

This function changes the playback tempo depending on direction of Jog dial rotation and speed of movement.

● FRAME SEARCH

Moves the disc from pause position in frame increments (1/75 sec) when the Jog dial is rotated in pause mode.

● SUPER FAST SEARCH

You can search the disc faster than normal search or track search by holding down a SEARCH button or TRACK SEARCH button as you turn the Jog dial.

TEMPO CONTROL

100 mm high-precision slider coupled with a 0.05% increment digital display (within a $\pm 6\%$ range) allows exact control of speed to make tempo adjustments easy and accurate.

● TEMPO CONTROL RANGE

The maximum variable range can be set to three variable ranges: $\pm 6\%$, $\pm 10\%$ and $\pm 16\%$ to facilitate adjustment.

● MASTER TEMPO

Changes playback tempo without changing pitch.

CUE

● BACK CUE

After storing the Cue point in memory, press the CUE button while playing to go back to the Cue point.

● AUTO CUE

Auto cue automatically locates the song's start point even if it differs from the track's frame, allowing the player to start instantly at a press of the PLAY/PAUSE (▶/||) button.

● CUE POINT SAMPLER

The sound from the memorized cue point can be reproduced by one touch, which can be used as the start point check and the sampler.

REAL TIME SEAMLESS LOOP

This function simplifies setting and releasing loops. This function lets you set a loop while you are playing a track. A loop can also be set at the end of the track so that the track does not stop. In addition, an ADJUST mode has been added to enable one-touch adjustment to the Loop-out point and facilitate loop operation.

RELOOP

Allows you to replay a loop any number of times.

Press the RELOOP button after releasing loop play to return to the loop start point. Clever use of on and off in combination with the rhythm make it possible to create new sound effects.

ONE TRACK LOOP

Automatically sets a loop from the beginning to the end of a track. Prepare the loop material first, and enjoy loop play by one touch.

CARD MIX

While playing a CD, you can mix sounds from a memory card (dual mode ⇄ P. 18).

● BPM SYNCHRO mixing

Automatically adjusts the playback speed of the memory card track to the tempo (BPM) of the currently playing CD.

● CARD TEMPO

Allows manual adjustment of the playback tempo of the memory card.

* During BPM synchro playback, this dial operates as the PITCH BEND function.

● PITCH BEND

By rotating CARD TEMPO dial, you can perform fine tuning of the playback speed of the memory card during BPM SYNCHRO (the speed changes in accordance with the direction the dial is turned). This feature thus allows the playback beat of the memory card to be matched to that of the CD.

ISOLATOR

This function allows the user to isolate and independently cut any of the three frequency bands (low, mid-range, high), thus allowing greater control over balance during dual-mode playback.

PLAYING ADDRESS

This bar graph provides a visual representation of track playback progress that enables you to see current playback position just like you can on an analog record by checking needle position. The length of the bar shows current position and a flashing bar provides advance notice of track end.

SLOT IN

Discs are loaded directly without opening doors or trays, making track selection that much faster.

FADER START

QUICK START and BACK CUE can be performed using the fader function on DJ mixers DJM-300, DJM-500, DJM-600 and DJM-3000 (all mixers are sold separately).

MULTI READ

CD-R, CD-RW discs can be replayed. (However, due to certain special characteristics of some discs, recorders as well as dirty or damaged discs, some discs may not replay properly.)

CD TEXT

Titles and artist names can be displayed during playback of discs supporting CD-TEXT.

CD-ROM

Supports playback of single-layer recorded MP3 audio data.

CONNECTIONS

- Before making or changing the connections, switch off the power and disconnect the power cord from the AC outlet.

1. Connecting to a DJ mixer (DJM-300, DJM-500, DJM-600, DJM-3000) (sound output and CONTROL terminal connection)

Use the supplied audio cables. Connect the white plug to the L (left) terminal and the red plug to the R (right) terminal.
Connect the supplied control cord to enable control of the unit from the mixer to allow fader start play and back cue.

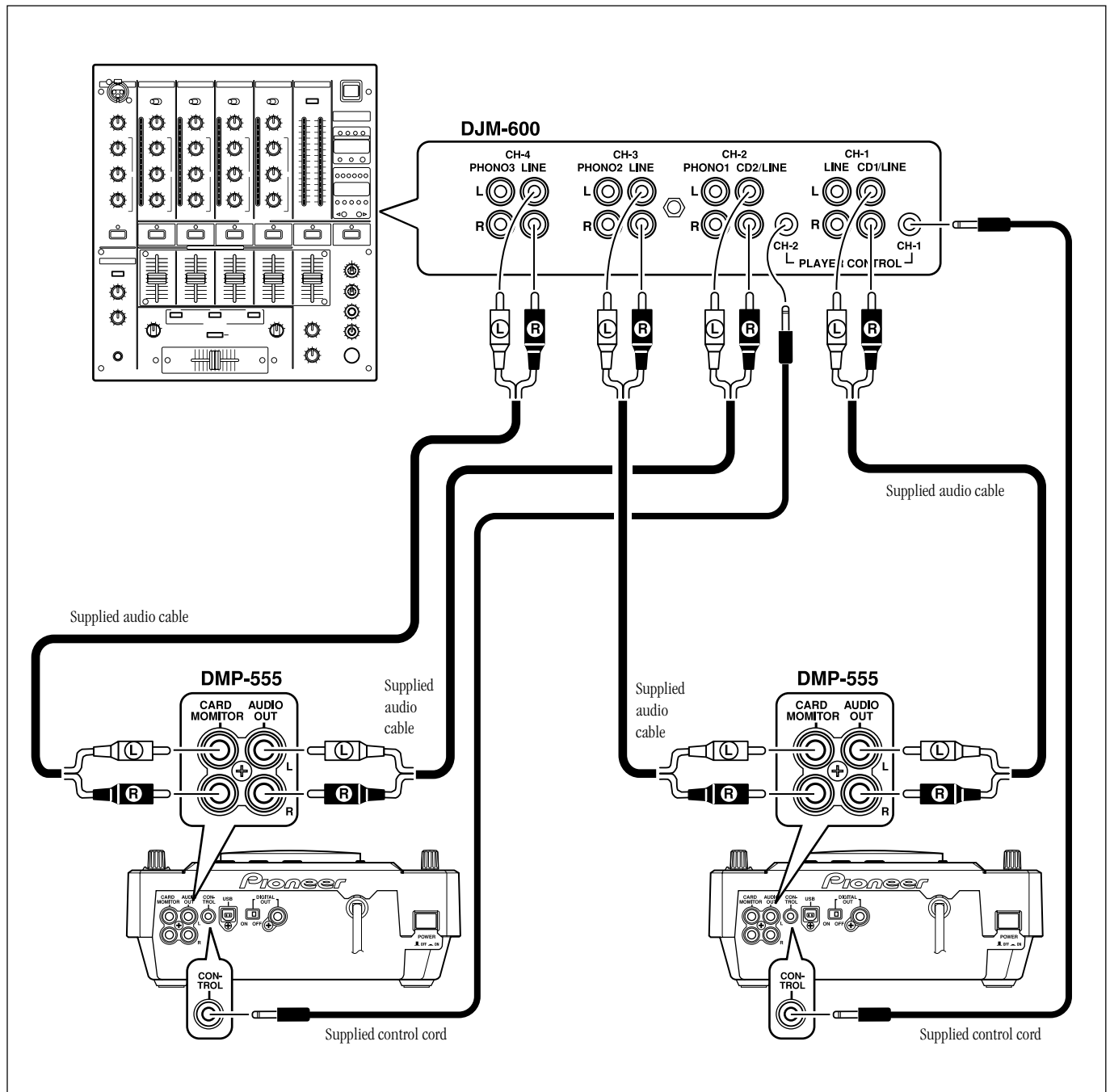

BEFORE OPERATIONS: CONNECTIONS

2. Connecting to a DJ mixer (DJM-300) and a CD player (CDJ-100S) (sound output and CONTROL terminal connection)

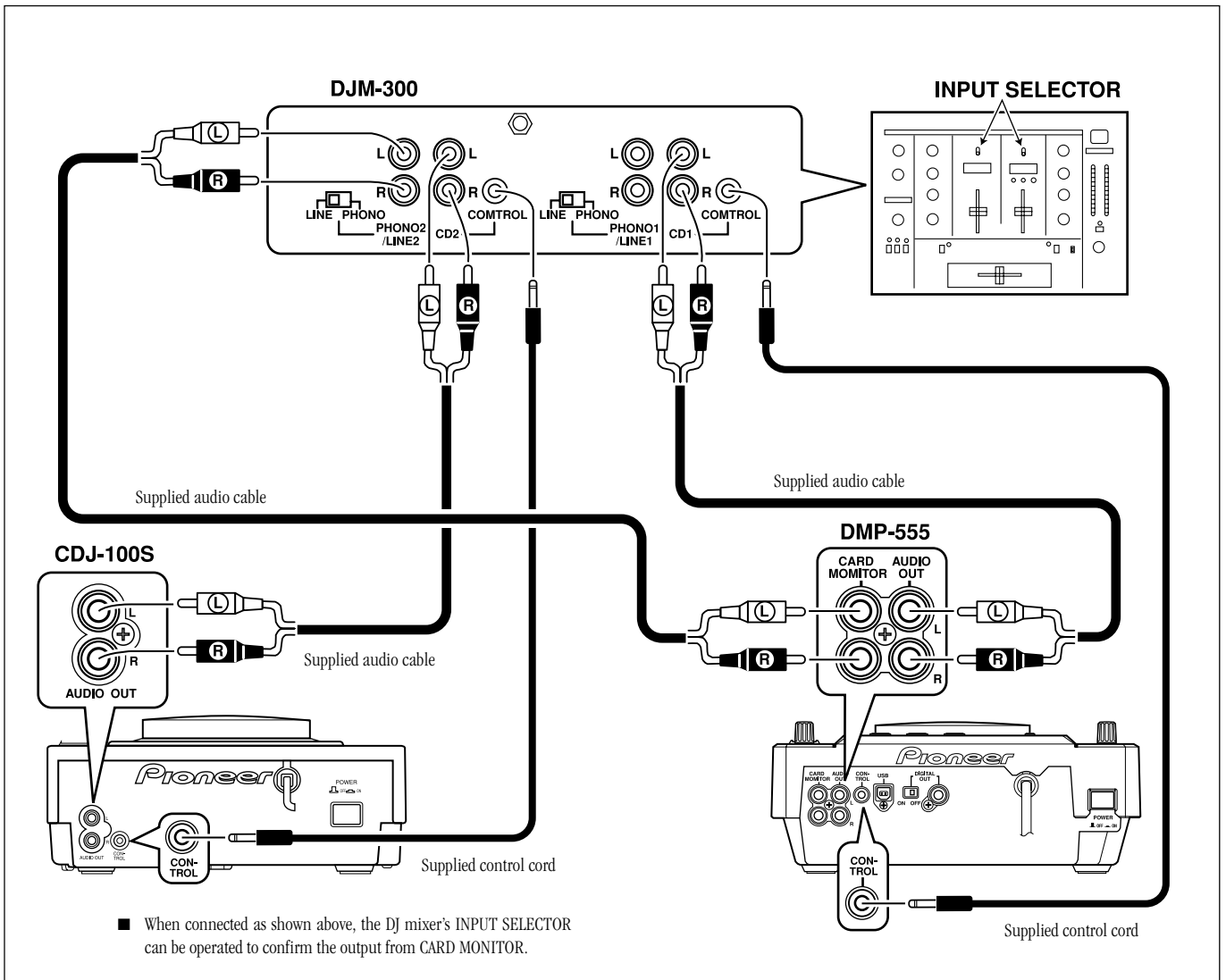

3. Connecting control cord to allow relay play

Alternate playback can be automatically performed when the CONTROL terminals of two units are connected with the supplied control cord. P.17

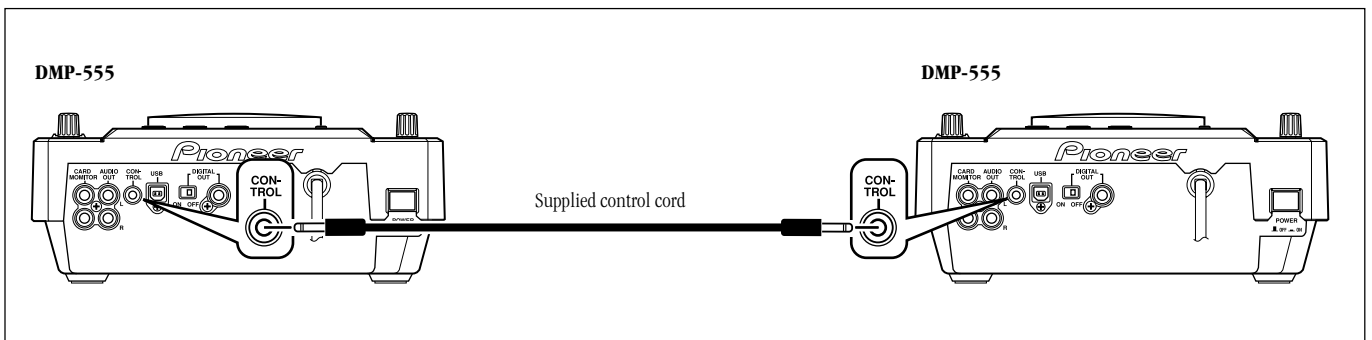

4. Connecting to other devices

A Connecting to other mixers

Connect the **AUDIO OUT** and **CARD MONITOR** terminals on the unit with the Line In terminals or AUX terminals on the mixer.
(Do not use the Phono terminals. Otherwise the sound will become distorted and prevent normal playback.)

B Connecting to a stereo amplifier (when not using a DJ mixer)

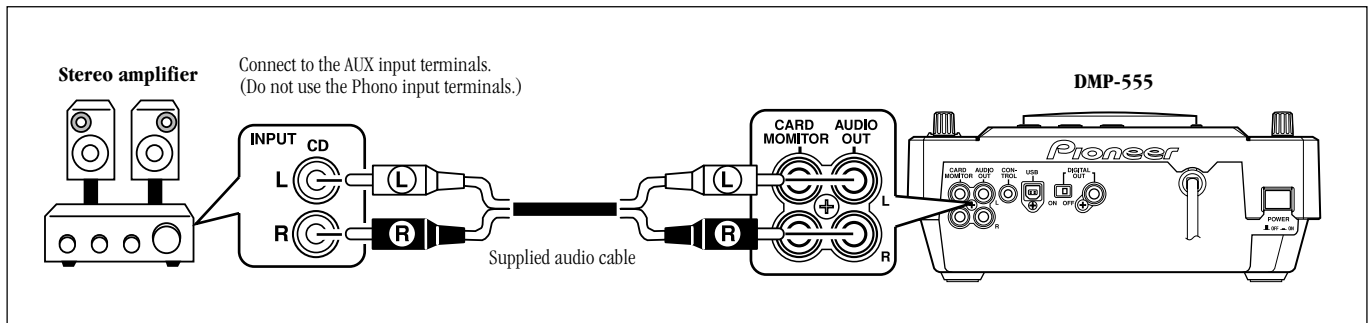

C Connecting to a component with a digital input terminal

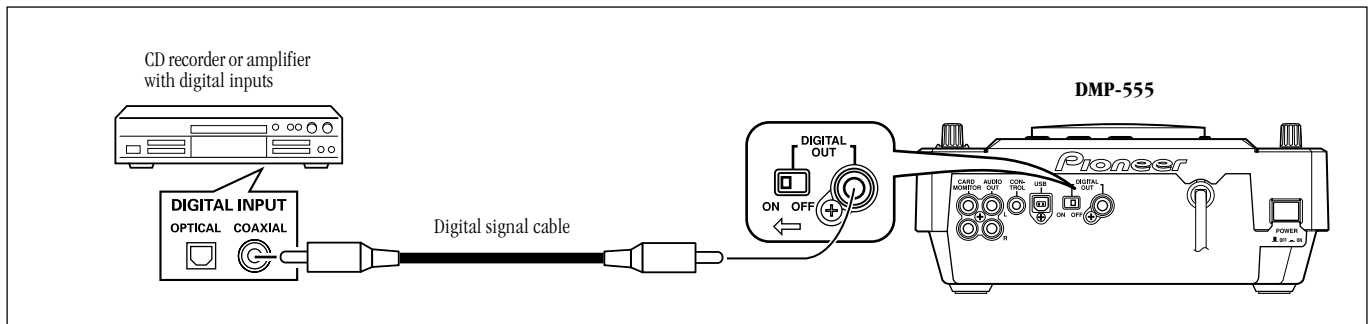

- Set the **Digital mode** switch (DIGITAL OUT) to ON when using the digital output terminal.

NOTE:

When the **Digital mode** switch (DIGITAL OUT) is set to ON, the DJ functions (cue, loop, reloop, tempo adjust, jog dial, Card mixing and Isolator) do not work. And the muted pause mode is used instead of the audible pause mode.

5. Connecting the power cord

When all connections have been made, connect the power plug to an AC wall outlet or to a power receptacle on the rear panel of the amplifier.

6. Computer connection

When the provided USB cable is used to connect the Digital media player's USB connector to a computer's USB connector, the Digital media player's jog dial and TEMPO control slider can be used to control the accessory software program "DJ Booth." The software (on CD-ROM) provided with the Digital media player must be installed on your computer in order for your computer to recognize the Digital media player. For details, consult the software installation manual.

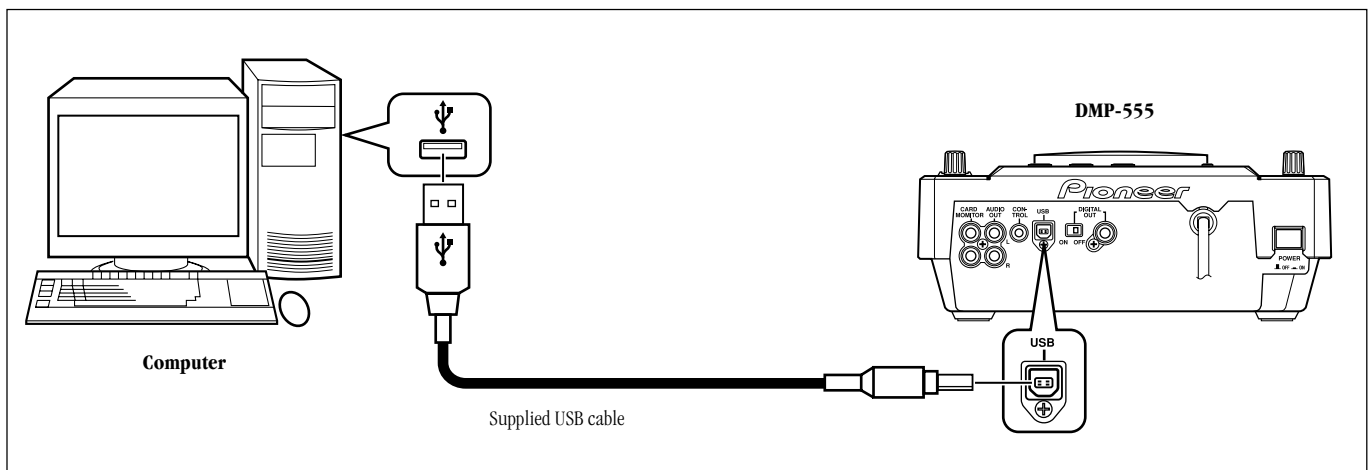

PANEL FACILITIES

Buttons indicated by * cannot be used in digital mode.

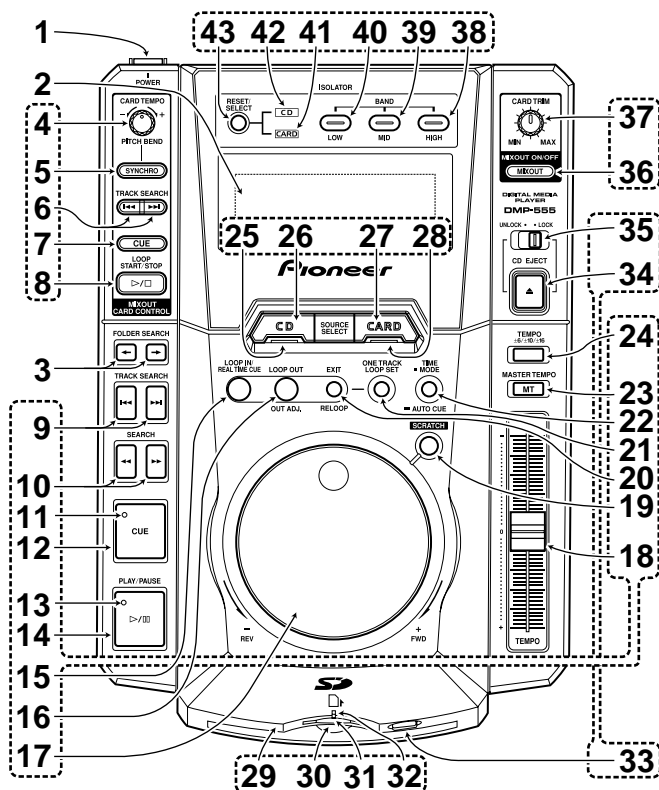

- 1 POWER switch (OFF / ON)**
Located on the unit's rear panel.
- 2 Display** ⇨ P. 51-76
- 3 FOLDER SEARCH buttons (←, →)** ⇨ P. 13
Use when performing track search of media with layered file structure (for example, CD-ROM or memory card).

[MIXOUT CARD CONTROL Block] (4~8)

- The buttons and other controls in this block are enabled only when source selector is set to CD.
- 4 CARD TEMPO dial (*)** ⇨ P. 19
Use to adjust the playback tempo of the track on the memory card being mixed with the currently playing CD (CD-DA track).
- 5 Card mix SYNCHRO button / indicator (*)** ⇨ P. 19
Use to turn the BPM synchro function ON/OFF. When ON, the playback tempo of the memory card track being mixed is automatically matched to the BPM rate of the currently playing CD (CD-DA track).
- 6 Card mix TRACK SEARCH buttons (|◀◀, ▶▶|)** ⇨ P. 18
- 7 Card mix CUE button / indicator (*)** ⇨ P. 18
When a memory card track is in cue pause mode, depressing this button plays back the cued track while the button is held depressed; when the button is released, the track returns to its cue point.
- 8 Card mix LOOP START/STOP button / indicator (▶/■) (*)** ⇨ P. 18
Use to perform seamless loop play/stop of the memory card track being mixed with the currently playing CD (CD-DA track).

[DJ Operation Block] (9~24)

- The buttons and other controls in this block operate with respect to the media designated by the source selector.
- 9 TRACK SEARCH buttons (|◀◀, ▶▶|)** ⇨ P. 14
- 10 SEARCH buttons (◀◀, ▶▶)** ⇨ P. 14

- 11 CUE indicator (*)** ⇨ P. 14
This indicator lights whenever a cue point has been set, except during searches. Flashes during pause mode.
 - 12 CUE button (*)**
[Setting a cue point] ⇨ P. 14
[Back cue] ⇨ P. 15
[Cue point sampler] ⇨ P. 15
 - 13 PLAY/PAUSE indicator (▶/■)**
Lights during play and flashes during pause.
 - 14 PLAY/PAUSE button (▶/■)** ⇨ P. 13
 - 15 LOOP IN/REAL TIME CUE button / indicator (*)**
Real time cue ⇨ P. 15
Loop-in point input ⇨ P. 16
 - 16 LOOP OUT/OUT ADJ. button / indicator (*)**
Loop-out point input ⇨ P. 16
Loop-out point adjust ⇨ P. 16
 - 17 Jog dial (*) (+FWD/-REV)** ⇨ P. 15
 - 18 TEMPO control slider (*)** ⇨ P. 15
Slide forward (+) to increase the playback tempo; move back (-) to reduce the playback tempo.
 - 19 SCRATCH button / indicator (*)** ⇨ P. 16
Use to switch jog dial function between scratch mode and CDJ mode.
• Defaults to CDJ mode each time power is turned ON.
 - 20 EXIT/RELOOP button (*)** ⇨ P. 16
Press for loop play of a single track.
 - 21 ONE TRACK LOOP SET button (*)** ⇨ P. 16
Press for loop play of a single track.
 - 22 TIME MODE/AUTO CUE button (*)**
TIME MODE: Pressing this button causes the time display to alternate between elapsed playing time and remaining playing time (REMAIN) of the currently playing track.
AUTO CUE mode: Hold button depressed for more than one second to switch AUTO CUE mode ON/OFF ⇨ P. 13.
 - 23 MASTER TEMPO button / indicator (*)** ⇨ P. 15
Pressing this button causes the master tempo function to alternate between ON and OFF.
 - 24 TEMPO control range button (*) (±6/±10/±16)**
Pressing this button causes the variable range of the TEMPO control slider to alternate between ±6%, ±10%, and ±16%.
- [SOURCE SELECT Block] (25~28)
- 25 CD indicator** ⇨ P. 13
Lights when CD is loaded. Flashes during CD eject.
 - 26 CD select button / indicator** ⇨ P. 13
When this button is pressed, the CD player is enabled as main source, enabling DJ play on CD-DA and CD-ROM.
 - 27 CARD select button / indicator (*)** ⇨ P. 13
When this button is pressed, the memory card is enabled as main source, enabling DJ play on SD card and MMC card.
 - 28 CARD indicator** ⇨ P. 13
Lights when a memory card is loaded and ready to play. The indicator flashes if the loaded card is not formatted correctly, or if it contains no track contents.
- [Slot Block] (29~32)
- 29 Forced eject hole** ⇨ P. 5
 - 30 Disc loading slot** ⇨ P. 12
 - 31 Memory card loading slot** ⇨ P. 12
 - 32 Slot indicator**
Lights when power is turned ON, and flashes while data is being written to the memory card.

[EJECT Block] (33~35)

33 CARD EJECT button (▲)

Do not press this button while the slot indicator is flashing.

34 CD EJECT button (▲)

When this button is pressed, the loaded disc stops rotating and the disc emerges from the disc loading slot. When the CD EJECT LOCK switch is set to LOCK, the disc will not be ejected unless the button is pressed from the pause mode.

35 CD EJECT LOCK switch**UNLOCK:** The loaded disc is ejected whenever the CD EJECT button is pressed, even from play mode.**LOCK:** The loaded disc is not ejected if the CD EJECT button is pressed from the play mode. To eject the disc, set the CD to pause first, then press the CD EJECT button.

[MIXOUT Block] (36~37)

36 MIXOUT button / indicator (*) *☞ P. 18*

When the source selector is set to CD, pressing this button to ON causes the memory card's track playback to be output to the AUDIO OUT connector.

37 CARD TRIM dial (*) *☞ P. 18*

Use to adjust the audio volume output to the CARD MONITOR connector when the source selector is set to CD.

[ISOLATOR Block] (38~43)

38 ISOLATOR BAND HIGH select button / indicator (*) *☞ P. 17*

Press to cut the high-range frequency band.

39 ISOLATOR BAND MID select button / indicator (*) *☞ P. 17*

Press to cut the mid-range frequency band.

40 ISOLATOR BAND LOW select button / indicator (*) *☞ P. 17*

Press to cut the low-range frequency band.

41 ISOLATOR CARD select indicator (*) *☞ P. 17***42 ISOLATOR CD select indicator (*)** *☞ P. 17***43 ISOLATOR RESET/SELECT button (*)** *☞ P. 17*

Use to select whether isolator function is applied to CD or memory card. Also press to reset the condition of isolator select buttons (HIGH, MID, LOW), and return to default OFF condition.

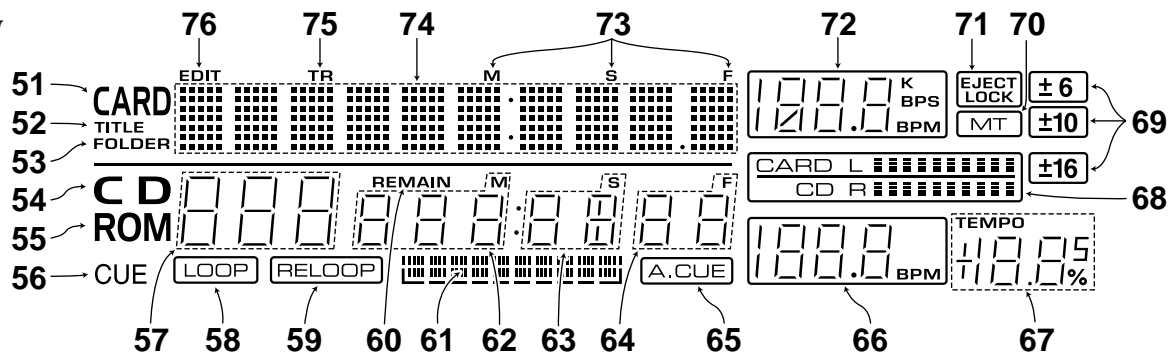
Display**51 CARD indicator**

Lights when the dot matrix displays information about the memory card.

52 TITLE indicator

Lights when the dot matrix displays track title information.

53 FOLDER indicator

Lights when the dot matrix displays folder name information.

54 CD indicator

Lights when CD player has been selected as main source.

55 CD-ROM indicator

Lights when a CD-ROM disc has been loaded in the CD player.

56 CUE indicator

Lights when a cue point has been set, and flashes to indicate that the player is in pause mode and a new cue point can be input.

57 Track number display.

Displays track numbers.

58 LOOP indicator

Lights during loop operation.

59 RELOOP indicator

Lights during reloop standby and loop operation.

60 REMAIN indicator

Lights to indicate that the track's remaining time is being shown.

61 Play status display

This bar graph scale provides a quick visual indication of the current point in playback. The full-scale bar graph indicates an entire track.

- During the elapsed time display, the graph lights from left to right.
- During the remaining time display, the graph goes out from left to right.
- When less than 30 seconds of playback time remain on a track, the display flashes slowly, then flashes quickly when less than 15 seconds of playback time remains.

62 Time (minutes) display (M)**63 Time (seconds) display (S)****64 Frame display (F)**

75 frames are equivalent to 1 second.

65 A.CUE indicator

Lights when Auto Cue is ON.

66 BPM counter display

Displays the beats-per-minute (BPM) of the currently playing track. Depending on content, the BPM counter may be unable to detect the BPM of some tracks.

67 TEMPO display

Displays how much change is being applied to playback speed by the TEMPO control slider.

68 Level meter (CARD, CD, L, R)**CARD:** Lights during memory card playback**CD:** Lights during CD playback**L, R:** Function as level meters for Left and Right channel during single playback.**69 Tempo control range indicators (±6, ±10, ±16)**

Indicates the variable adjustment range selected with the TEMPO control range button.

70 Master Tempo indicator (MT)

Lights when the master tempo function is ON.

71 EJECT LOCK indicator

Lights when the CD EJECT LOCK switch is set to the LOCK position.

72 Card playback bit rate / BPM display (K BPS, BPM)

During dual mode playback, displays the memory card playback bit rate or memory card BPM.

K BPS: Kilobits Per Second**73 Card time in Minutes/Seconds (M/S) / Frame (F) indicator**

Lights during dual-mode playback to indicate the dot matrix panel is displaying memory card time/frame information.

74 Dot matrix display panel

Displays alphanumeric data.

75 Card track indicator (TR)

Lights during dual-mode playback to indicate the dot matrix panel is displaying memory card track information.

76 EDIT indicator

Lights when unit is in edit mode.

DISC AND MEMORY CARD LOADING/UNLOADING

DISC LOADING

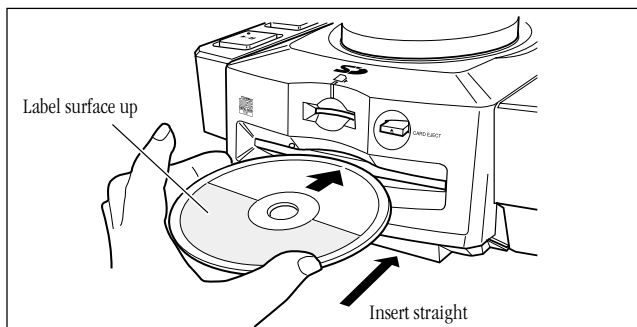

1. Set the rear-panel POWER switch to ON.

Do not force a disc into the unit when the POWER switch is set to OFF as this may damage the disc and the unit.

2. Insert a disc.

- Hold the disc with label surface upwards, and insert into the front panel disc loading slot.
- When playing 8cm discs, be sure to install an adaptor.

This unit spins at high speed to provide high performance. When playing 8cm discs with an adaptor, for safety reasons the rotation speed is reduced.

- Only one disc can be loaded at a time. Never attempt to load more than one disc at the same time, or attempt to load a second disc when one disc has already been loaded.
- When loading a disc, do not place any twisting force on the disc, or try to force the disc into the slot. Also, do not attempt to interrupt or defeat the motion of the disc when the player begins to draw a disc into the slot or to eject a disc, since damage to the disc or player could occur.

3. The disc can be ejected anytime using the CD EJECT button (▲) when the CD EJECT LOCK switch is set to UNLOCK. When the CD EJECT LOCK switch is set to LOCK, press the PLAY/PAUSE button (▶/⏸) during playback, or when a Cue point has been set, press the CUE button (back cue) before pressing the CD EJECT button (▲) to eject the disc.

- When the CD EJECT button is pressed, disc rotation stops and the disc is ejected from the loading slot.
- If the disc cannot be ejected with the CD EJECT button, insert a pin in the forced eject hole on the front panel of the player. ☞ P. 5

CAUTION:

Do not attempt to press a disc back into the slot when the [EJECT] display appears. Pressing a disc back into the slot while the [EJECT] display appears may cause the player to stop. In this case, press the CD EJECT button again and wait until the [EJECT] display goes out before reinserting the disc.

PRECAUTIONS ON PLAYING CD SINGLES (8 cm/3-inch Discs)

- ① When playing CD singles (8 cm/3-inch discs), always use the adapter for 8 cm/3-inch discs. Before loading the disc into the CD player, be sure to check that it is secured properly by the catches of the adapter. If discs have been inserted without the adapter by mistake, remove the disc immediately by pressing the eject button. If the disc does not come out with one press, press another time.
- ② Use 8 cm/3-inch disc adapters labeled with the  mark (recommended standard product). Do not use adapters which cause the disc to idle, nor adapters which are bent or curved.

LOADING A MEMORY CARD

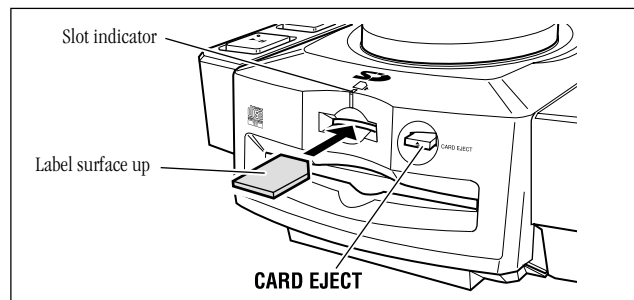

This unit supports use of SD memory cards. Hold the card flat with label surface facing up, and the cutaway corner forward. Press gently into the card loading slot until it is drawn.

● To remove card

Press the **CARD EJECT** button when the memory card is not being used for playback or write operations. The card will emerge slightly from the slot; remove it by gently pulling out in a straight line.

■ Precautions Regarding Handling and Storage of Memory Cards.

- Do not attempt to disassemble or modify memory cards.
- Do not expose memory cards to moisture, strong impact, bending, or dropping.
- Do not touch the card's metallic contacts with fingers or metal objects.
- Do not attempt to remove the label affixed to the surface.
- Do not leave memory cards inside automobiles in sunlight, or other locations exposed to high temperatures or direct sunlight.
- Do not leave memory cards in locations exposed to high humidity or dust concentrations.
- Do not leave memory cards in locations exposed to caustic gases.
- Do not use or store memory cards in environments exposed to the generation of static electricity or electrical noise.

■ Formatting SD Memory Cards

This unit cannot be used alone to format memory cards. To format a memory card, use the accessory USB cable to connect the Digital Media Player to a computer, then use the "DJ Booth" function on the accessory DJ application software. Note that malfunctions may result if other USB reader/writer software is used to format a memory cards.

To Protect Important Data

- Set the write protect switch to LOCK. If you subsequently wish to record new data, or to edit previously recorded data, reset the switch to the unlocked position.
- The slot indicator flashes during data write operations. Do not attempt to remove the memory card, turn off the power to this unit or to the computer, nor disconnect the USB cable while the indicator is flashing. Any of these actions may result in loss of data. Pioneer assumes no responsibility for loss of data or other direct or indirect damages that may occur.
- Note that SD memory cards created with SD AUDIO formatting are equipped with a powerful copyright protection function; as a result, even if "Explorer" or other applications are used to make backup copies of the contents of a SD card, the resulting file will not be playable. MP3 files downloaded from the Internet, and MP3 files ripped from CDs should be backed up to other media (CD-R, etc.). This digital media player also supports playback of MP3 files recorded on CD-ROM and multimedia cards (MMC).

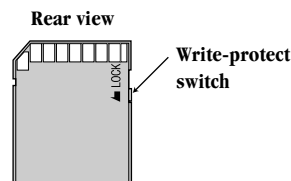

DJ PLAYER OPERATION

This player supports playback of both Compact Discs and memory cards. When using memory cards, it is necessary to record the tracks by connecting this unit to a computer via a USB cable. For details, consult your software operating instructions.

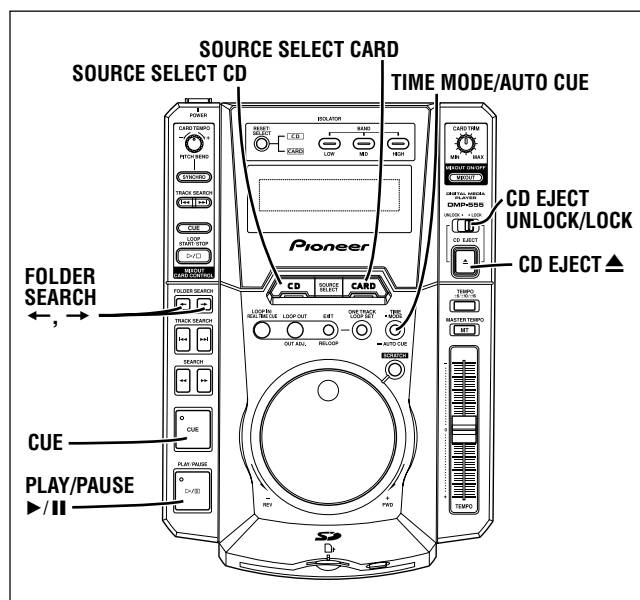

Auto Cueing (*)

Auto cueing is used to automatically specify the Cue point (☞ P. 14) to be used before sound actually begins to play when inserting a disc or when performing track searching.

● Turning auto cueing on and off

Pressing the **TIME MODE/AUTO CUE** button and holding it down for a second or more causes auto cueing to be alternately turned on and off.

When **AUTO CUE** is on, the **[A. CUE]** indicator will be lit up.

- The auto cue level is set at -60dB.

To Begin Playback

1. Load a disc in the player, or insert a memory card containing a recorded track.

- The CD indicator lights when a disc is loaded.
- The CARD indicator lights when a memory card is loaded.
- MMC cards created on devices equipped with security functions, or MMC cards formatted using proprietary formats are not supported (the CARD indicator will not light when the card is loaded).

2. Press the SOURCE SELECT button (CD or CARD) to select the source.

- The selected source button indicator (**[CD]** or **[CARD]**) will light.
- When the auto cue function is ON, the unit will enter cue pause at the beginning of the track.
- No sound will be heard if a select button is pressed when no media is loaded corresponding to the pressed button.
- If the **CD** select button is pressed during playback of a memory card, the card will enter silent pause at the beginning of the track that was playing.
- If the **CARD** select button is pressed during CD playback, the CD will enter silent pause at the beginning of the track that was playing.
- If the **CARD** select button is pressed during dual mode playback (☞ P. 18), the playback will return to the beginning of the card's currently playing track, and playback will begin again.
- The **CARD** select button does not operate when the Digital mode switch (DIGITAL OUT) is set to ON (when digital output connectors are being used).

Functions indicated by * cannot be used when the Digital mode switch (DIGITAL OUT) is set to ON (and the digital output terminal is used).

3. If auto cueing is on, press the PLAY/PAUSE button (►/||).

- Wait for the **CUE** button indicator to light up before pressing the button. The silent portion at the beginning of the displayed track will be skipped and playback will begin instantaneously from the first bars of the track.

Once the first track has been played, the player will automatically search for the beginning of the next track to be played. The **[CUE]** indicator will light up, the **PLAY/PAUSE** button indicator will flash, and the player will then wait for the **PLAY/PAUSE** button (►/||) to be pressed before beginning playback of the next track.

If auto cueing is off, playback will begin automatically from the first track.

- When auto cueing is off, playback will continue after the first track has been played, with all subsequent tracks being played in sequence.
- When playback of the final track is complete, playback will automatically come to an end.

Stopping Playback

Press the **CD EJECT** button (▲) when the **CD EJECT LOCK** switch is set to **UNLOCK**.

When the **CD EJECT LOCK** switch is set to **LOCK**, press the **PLAY/PAUSE** button (►/||) during playback, or when a Cue point has been set, press the **CUE** button (back cue) before pressing the **CD EJECT** button (▲) to eject the disc.

- Playback will stop and the disc will be ejected.
- Note that the DMP-555 does not come with a stop button.

To Pause Play

During playback, press the **PLAY/PAUSE** button (►/||).

- The **PLAY/PAUSE** button indicator and **[CUE]** indicator will flash, and play will be paused.
- When the **PLAY/PAUSE** button is pressed again, play will resume and the **PLAY/PAUSE** button indicator will light steadily.
- In the CDJ mode broken sound will still be audible during the pause mode; if you wish to stop all sound, lower the output sound volume on your audio mixer.
- When the unit has not been operated for 80 minutes or more in pause mode, the disc rotation stops automatically. In this instance, playback can be resumed by pressing the **PLAY/PAUSE** button.

Folder Search

When performing track search on media with layered file structures (CD-ROMs and memory cards), press the **FOLDER SEARCH** buttons (◀, ▶) to select a folder.

Press the **FOLDER SEARCH** button (◀, ▶) during playback

- When the button is pressed, the present folder number and name will be displayed. If no folder is present, the display will show "NO FOLDER." If other folders are present, the root will be indicated by "00"; folder numbers and names are displayed for five seconds, after which the display returns to show the original title.
- If the ◀ or ▶ button is pressed during display of folder numbers and names (example: **00 Root**), the search function will move in the selected direction and the next folder number and name will be displayed (example: **01 TECHNO**); the search will then look for first track in the newly selected folder. Folders containing no playable tracks (empty folders) are ignored, and the search function automatically moves to the next folder.
- The new folder number and name are displayed for two seconds, after which the title of the folder's first track is displayed.
- If the folder name is composed of more than 8 characters, the title will begin scrolling after one second; since the display will not return to the title display until the entire folder name has been displayed, it is advisable to use 7 or fewer characters when possible to designate folder names.

BASIC OPERATION: DJ PLAYER OPERATION

- If the button is held depressed, the search will continue to increment (or decrement) through subsequent folders at the rate of one folder per second. If the button is subsequently held depressed, the speed of search will be increased by a factor of ten.
- If the back button ← is pressed when “00” is displayed, the search will move to the last folder on the media; likewise, if the forward button → is pressed when the last folder number is displayed, the search will jump to “00” (root directory).
- Only one level of folders will be searched. If other folders exist within a folder, they are treated automatically as new folders.
- In the case of SD AUDIO formatting, individual play lists are treated as folders.

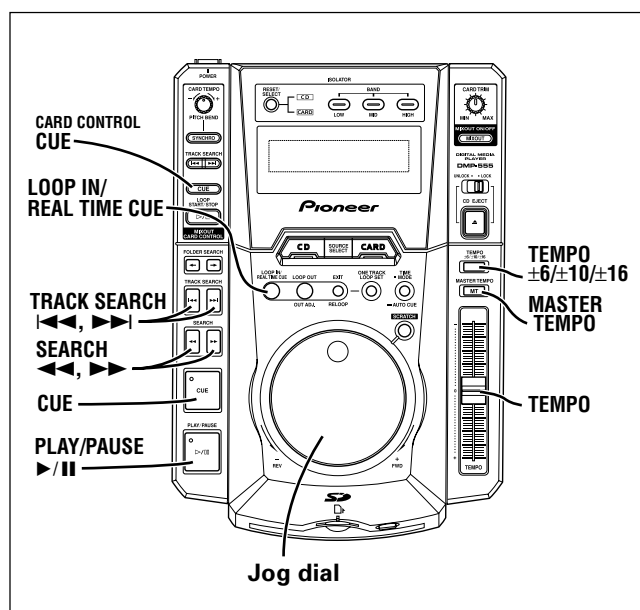

To Skip To Other Tracks

- **Using the TRACK SEARCH buttons (←, →)**
Press one of the TRACK SEARCH buttons (←, →).
 - Each time the button is pressed, the search function will skip to the beginning of the next track in the direction indicated (to skip to the beginning of the track preceding the current track, press the ← button twice). When auto cue is set to ON, the search function will stop at the beginning of the track and enter the cue pause mode.
 - If the button is held depressed, the search function will skip to other tracks continuously. If the button is held depressed for more than two seconds, the speed of skipping will increase.
 - If the back (←) button is pressed from the lowest numbered track, the search function will skip to the last (highest numbered) track.
 - If the forward (→) button is pressed from the highest numbered track, the search function will skip to the first (lowest numbered) track.
 - If you wish to search within a specific folder of a CD-ROM, use the **FOLDER SEARCH** button (←, →) first to designate the desired folder; in this way, the track search function will operate on the tracks in the selected folder. If no folder is designated, the search function will be performed only within the tracks located in the root directory.
 - If you wish to search within a specific play list of a memory card, use the **FOLDER SEARCH** button (←, →) first to designate the desired play list; in this way, the track search function will operate on the tracks in the selected play list. If no play list is designated, the search function will be performed within all tracks located in the memory card.

- **Super-Fast Track Search**
Rotate the Jog dial while pressing one of the TRACK SEARCH buttons (←, →).

- While holding either one of the buttons depressed, rotate the Jog dial in the direction corresponding to the direction you wish to skip; the unit will enter the high-speed skip mode.
- The direction of skip is in accordance with the direction in which the Jog dial is rotated. The direction of the **TRACK SEARCH** button is ignored.
- Release the **TRACK SEARCH** button to exit this mode.

Fast-Forward / Fast-Reverse

- **Operation using the SEARCH buttons (←, →)**
Press the SEARCH buttons (←, →) during playback.
 Press and hold the → button to fast forward the disc; press and hold the ← button to do fast reverse.

- **Super-Fast Search**
Rotate the Jog dial while pressing one of the SEARCH buttons (←, →)
 - Hold down the button while turning the Jog dial in the direction you wish to search to enter fast forward or fast reverse mode.
 - The direction of the search is determined by the direction the Jog dial is turned. The direction of the **SEARCH** button is ignored.
 - When you stop turning the Jog dial, the unit returns to playback mode.
 - Release the **SEARCH** button to exit this mode.

Setting a Cue Point (*)

By setting a cue point, you can press the **CUE** button any time during playback to have the unit quickly jump to the cue point and stop there in the cue pause mode. Independent cue points can be set for CD and memory card.

- **Manual Cue**
 1. **During playback, press the PLAY/PAUSE button (▶/II) to pause playback at the point you wish to begin playback.**
 2. **Search for the precise position of the Cue point.**
 - **Using frame numbers to specify Cue points.**
 Cue points may be specified in 1-frame units (where 75 frames are equivalent to 1 second).
 Use the Jog dial or the forward or reverse **SEARCH** button (←, →) to advance to the desired frame. Rotating the Jog dial once causes the player to advance or rewind 80 frames in the specified direction.
 - **Listen to the sound at the current frame to determine the Cue point.**
 Turn the Jog dial slowly and then return it to just before the point from which you wish to begin playback. (The cue point thus defined will consist of that point directly after the sound which can be heard during a cueing pause.)
 3. **Press the CUE button when you reach the desired frame number or hear the sound at the point from which you wish to begin cueing.**
 - When the sound is muted and the [CUE] indicator lights up, the Cue point will have been stored to memory.
 - Each time a new Cue point is stored to memory, the previous Cue point will be erased.

[Changing a Cue Point]

1. **During playback, press the CUE button.**
 - The unit will return to the previously set cue point.
2. **Press the SEARCH buttons (←, →) to set to audible pause mode.**
3. **Perform steps 2 and 3 of the section “Setting a Cue Point”.**

■ **Real-time cue**

During playback, press the LOOP IN/REALTIME CUE button at the desired Cue point.

- This point will then be recorded as the new Cue point.

■ **Checking cue points (Cue point sampler)**

After specifying a cueing point, press the CUE button.

- The sound at the specified Cue point will continue to play as long as the CUE button is pressed.

Cue points on a memory card can be copied to the CUE button on the MIXOUT CARD CONTROL block. After setting a cue point, press the MIXOUT CARD CONTROL block's CUE button. The [CUE] button indicator will flash for four seconds, then switch to steadily lighted, indicating the cue point has been copied. The MIXOUT CARD CONTROL block's CUE button will function as a cue point sampler during dual mode playback (☞ P.18).

■ **Returning to a Cue point (Back cue)**

1. **During playback, press the CUE button.**

- The player will return to the specified Cue point.

2. **Press the PLAY/PAUSE button (▶/⏸).**

- Playback will begin immediately from the specified Cue point.

Changing Playback Speed (*)

Move the TEMPO control slider towards you.

Move the slider towards you (+) to increase the tempo and move it away from you (-) to decrease it.

- The rate of change in playback speed (tempo) is shown in the display.
- The playback speed can be changed without changing the pitch (☞ "Applying Master Tempo").

■ **Selecting range of tempo adjustment**

Press the TEMPO control range button (±6/±10/±16).

Each time the button is pressed the variable range of the TEMPO control slider changes as follows: ±6%, ±10% and ±16%. You can adjust as follows: at ±6% : 0.05% units, at ±10% and at ±16% : 0.1% units.

- The set variable range value is indicated in the display.

Applying Master Tempo (*)

Press the MASTER TEMPO button during playback.

The MASTER TEMPO button and the [MT] indicator light. The speed (tempo) can now be changed using the TEMPO control slider but the pitch (key) does not change.

- The sound's tone color will change due to digital processing, but this is not a malfunction.

Jog Dial Function (*)

1. **Rotate during playback (pitch bend)**

This function operates when the SCRATCH button is set to OFF (SCRATCH button indicator is not lighted).

- Accelerates (FWD+) and decelerates (REV-) in proportion to the amount of dial rotation.
- When dial rotation is stopped, tempo returns to previous speed.

2. **Rotate during playback (scratch play)**

This function operates when the SCRATCH button is set to ON (SCRATCH button indicator is lighted). For details, see page 16, "Scratch Play."

3. **Rotate during pause (frame search)**

This function operates when the SCRATCH button is set to OFF (SCRATCH button indicator is not lighted). During playback press the PLAY/PAUSE button (▶/⏸) to pause playback while allowing intermittent audio (audible pause). Rotating the Jog dial in this condition causes the playback point to be changed (search) while listening to the output.

- Search is performed frame by frame.
- Each rotation of the Jog dial plays back 80 frames of audio.

4. **Rotate after pressing SEARCH button in cue pause mode (cue point search)**

This function operates when the SCRATCH button is set to OFF (SCRATCH button indicator is not lighted). From the cue pause mode, press one of the SEARCH buttons (◀◀, ▶▶) to enter audible pause. Rotating the Jog dial allows you to search for potential cue points. After searching, press the CUE button to set the new cue point.

5. **Rotate during playback while holding the SEARCH button depressed (super-fast search)**

While holding one of the SEARCH (◀◀, ▶▶) buttons depressed, rotate the Jog dial in the desired search direction to perform high-speed search. Playback resumes when the Jog dial is released.

6. **Rotate while holding TRACK SEARCH button depressed (super-fast track search).**

While holding one of the TRACK SEARCH (◀◀, ▶▶) buttons depressed, rotate the Jog dial in the desired search direction. High-speed track search will be performed in accordance with the direction and amount of Jog dial rotation. The search mode is canceled when you remove your finger from the TRACK SEARCH button.

ADVANCED OPERATIONS

Functions indicated by * cannot be used when the Digital mode switch (DIGITAL OUT) is set to ON (and the digital output terminal is used).

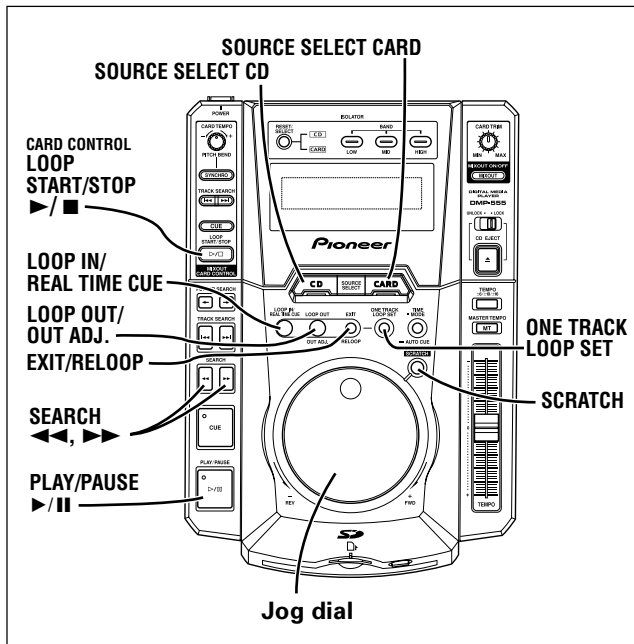

Scratch Play (*)

With the **SCRATCH** button set to ON (**SCRATCH** button indicator lights), rotate the Jog dial; scratch play is performed in accordance with the direction and speed of dial rotation.

1. **Press the SCRATCH button so that the SCRATCH button indicator is lighted.**
 - When the **SCRATCH** button is pressed the **SCRATCH** button indicator flashes as data is stored in memory. When data storing is completed, the flashing indicator lights steadily. If the Jog dial is moved erratically for scratch play while the indicator is flashing, sound may be distorted.
2. **Rotate the Jog dial in the direction and at the speed desired.**
 - CD playback will occur in response to the direction and speed of Jog dial rotation.
3. **When Jog dial rotation is stopped:**
 - CD playback returns to its original condition.

Loop Play (*)

■ **To create a loop:**

Independent loops can be created for CD and memory cards.

1. **Press the PLAY/PAUSE (▶/⏸) button to begin playback.**
2. **During either playback or audible pause mode, press the LOOP IN/REAL TIME CUE button at the desired loop-in point.**

- This step is not necessary if you wish to use a pre-selected cue point as the beginning point for the loop.

3. **As playback continues, press the LOOP OUT/OUT ADJ. button at the desired loop-out point.**

- Loop play will begin between the loop-in and loop-out points.

■ **To exit from a loop (cancel loop)**

During loop play, press the EXIT/RELOOP button.

- When the play reaches the end of the loop, the loop-out point will be ignored and normal playback will continue uninterrupted.

■ **To change the loop-out point**

1. **During loop play, press the LOOP OUT/OUT ADJ. button.**
 - The display will show the out point time, the **LOOP OUT/OUT ADJ.** button indicator will flash rapidly, and the **LOOP IN/REAL TIME CUE** button indicator will go out.
2. **Press the SEARCH button (◀◀, ▶▶), or rotate the Jog dial.**
 - The loop-out point will move in 1-frame increments.
 - The loop-out point cannot be moved to any position before the loop-in point.
 - To cancel the loop-out adjust mode, either press the **LOOP OUT/OUT ADJ.** button, or wait thirty seconds and the function will automatically return to loop play.

■ **To return to a loop (RE-LOOP)**

During playback, press the EXIT/RELOOP button.

- Playback will return to the previously set loop-in point, and loop play will recommence.

■ **To play a single track as a loop (one-track loop)**

During playback or audible pause mode, press the ONE TRACK LOOP SET button.

- A loop will be automatically created using the start of the currently playing track as the loop-in point, and the track end as the loop-out point; loop play will begin automatically.
- Note that if the start and end of the track includes silent (non-recorded) intervals, the loop will include those silent intervals.
- The loop-out point can be modified by following the procedures in the section "To change the loop-out point."

■ **To set a loop on the memory card during dual mode playback (For details, see P. 18)**

Ordinarily, when memory card playback is mixed with CD playback, the memory card is set for one-track loop. It is possible, however, to set a specific loop range if desired.

1. **Press the SOURCE SELECT CARD button ([CARD] button indicator lights), then play the track you wish to use for looping.**
2. **Set the loop-in and loop-out points.**
3. **Press the CUE button in the MIXOUT CARD CONTROL block.**
 - This completes setting of the loop on the memory card.
 - To start playback of the selected loop on the memory card, press the **SOURCE SELECT CD** button ([CD] button indicator lights), then press the **LOOP START / STOP** button (▶/■) in the **MIXOUT CARD CONTROL** block.
 - When the playback track on the memory card is changed, the previously set loop range is canceled.

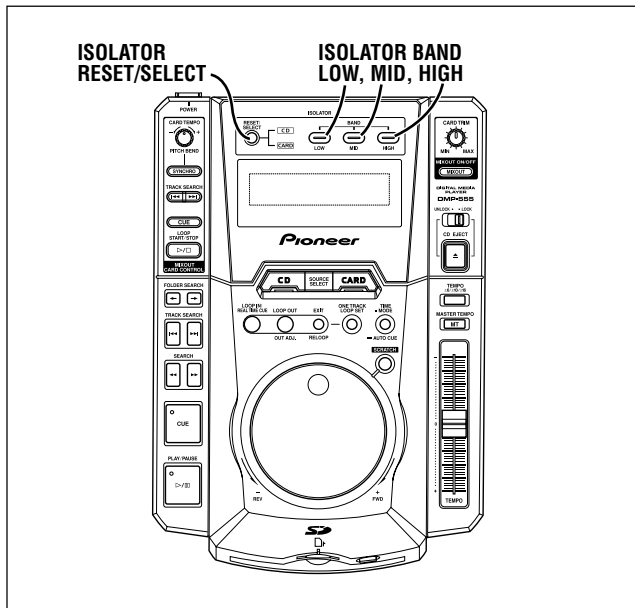

Isolator Function (*)

Using this function allows the user to isolate the audio spectrum into three frequency ranges (LOW, MID and HIGH), and freely cut or combine any of the ranges as desired.

1. Press the ISOLATOR RESET/SELECT button and select whether the isolator function is to be applied to CD or memory card (in dual mode P. 18).

- Even when in dual mode, the isolator function can be applied to only one of the two media sources (CARD or CD).
- When entering dual mode, the **ISOLATOR [CD]** indicator will light. The playback audio from the memory card is throughput on all frequencies, but the CD sound will continue to be modified by the isolator setting made previous to loading of the memory card.
- If you wish to apply isolator settings to the memory card playback in dual mode, press the **ISOLATOR RESET/SELECT** button. The **ISOLATOR [CARD]** indicator will light, and both CD and memory card will have throughput on all frequencies. The isolator function can be applied to memory card playback.
- In CD (single) mode and CARD (single) mode, the isolator function switches automatically to apply isolator effects on whichever media is being played; when this occurs, either the **ISOLATOR [CD]** or **ISOLATOR [CARD]** indicator will light to indicate to which media source the effect is applied.
- In single mode, the **ISOLATOR RESET/SELECT** button operates as a band reset function; the **LOW**, **MID**, and **HIGH** buttons will all light, indicating throughput on all frequencies.

2 Press the ISOLATOR BAND button (LOW, MID or HIGH) corresponding to the band you wish to cut.

- The pressed button indicator will go out and the corresponding frequency band will be cut.
- If all three buttons **LOW**, **MID**, **HIGH** are pressed, all bands will be cut, and no sound will be heard from the playing media; in this case, the **LOW**, **MID**, and **HIGH** buttons will all flash as a warning.
- Regardless of the current mode (dual or single), pressing the **ISOLATOR RESET/SELECT** button causes all frequency bands to be reset for full throughput (band reset). In dual mode, however, the media will also switch.

NOTE:

- When an **ISOLATOR BAND** button indicator is lighted, the corresponding frequency band is not cut (sound is audible). The button indicator goes out to indicate that a band has been cut (isolator effect is applied). Take care to note this difference and prevent mistaken use.
- This function is not supported in digital mode.
- If the media source (CD/CARD) is switched while the isolator is operating, the selected **ISOLATOR BAND** function will be applied to the newly selected media.

Fader Start Playback (*)

The supplied control cord may be used to connect the CONTROL terminal on the DMP-555 to a CONTROL terminal on a DJM-300, DJM-500, DJM-600, or DJM-3000 mixer, thus making it possible to exit from cueing standby mode and to start playback immediately by raising the DJ mixer channel fader. The cross fader may also be used to perform fading starts on the player as well. The fader may also be returned to its original position to return the player to the cueing point (i.e., to perform back cueing).

(See page. 7 for instructions on how to connect the player.)

Relay Play Using Two Players (*)

If you connect the CONTROL terminals of this player with another CDJ series (or CMX series) CD player using the supplied control cord then you will be able to relay play. P. 8.

- Set both player's auto cue function to ON (the **[A. CUE]** indicators will light in the displays).
- Set your audio mixer's fader control to its center position.

- 1. Begin playback on the first player.**
- 2. When the currently playing track ends, playback will begin automatically on the standby player.**
- 3. The first player will enter CUE pause mode at the beginning of the next track on its disc.**

- By repeating this operation, the two players can be used to perform continuous relay play.
- By loading new discs on the standby player, you can construct a continuous program of whatever tracks you wish.
- By setting a Cue point on the standby player, you can perform relay to any desired Cue point on the selected track (see page 14: Setting a Cue Point).

NOTE:

- Relay play may not operate properly if the audio out jacks on the two players are not connected to the same audio mixer.
- If the power to one player is turned off during its playback, the other player may begin playback.
- Fader start and relay play cannot be performed simultaneously, since different control cord connections are required.

CARD MIXING (dual mode)

Functions indicated by * cannot be used when the Digital mode switch (DIGITAL OUT) is set to ON (and the digital output terminal is used).

The card mix function allows you to mix playback from a memory card with playback of a CD-DA.

- Card mix is not supported for CD-ROM.

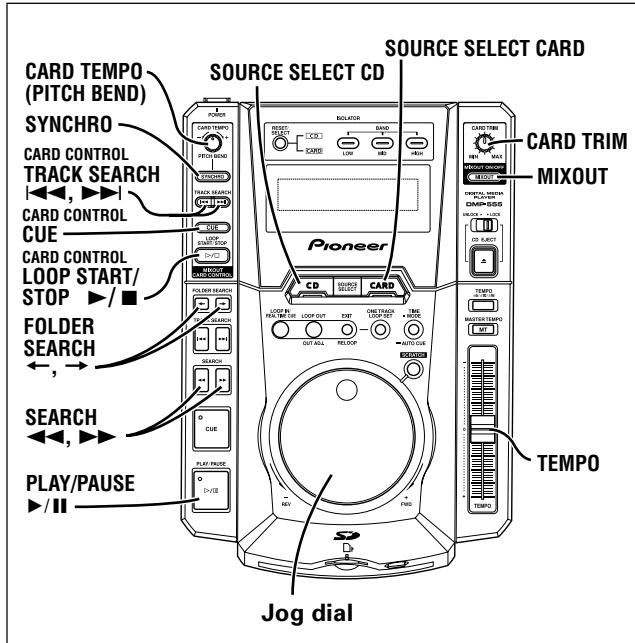

Card Mix Output Settings (*)

In dual mode, the CARD MONITOR connectors output the sound from the memory card. This output allows the user to perform track selection or check the contents of a memory card while simultaneously playing a CD.

- When source selector is set to CARD (SOURCE SELECT [CARD] button indicator is lighted), no sound will be output from the CARD MONITOR connectors.

AUDIO OUT connector settings

This setting determines whether sound from a memory card's track is output at the AUDIO OUT connectors when the source selector is set to CD (SOURCE SELECT [CD] button indicator is lighted).

- With the mix output set to OFF, perform track selection or check the contents of the memory card as desired; then set to cue pause mode, and set the MIXOUT button to ON.

Press the MIXOUT button.

- When the [MIXOUT] button indicator lights, the memory card's track sound is output at the AUDIO OUT connectors.
- Even if no CD is currently playing, when the [MIXOUT] button indicator lights, the memory card's sound is output at the AUDIO OUT connectors.

Adjusting card playback volume

When the source selector is set to CD (SOURCE SELECT [CD] button indicator is lighted), this adjusts the sound volume of the memory card playback heard at the CARD MONITOR and AUDIO OUT connectors.

Rotate the CARD TRIM dial.

- Adjustment range is $-\infty$ to $+12$ dB.
- When source selector is set to CARD (SOURCE SELECT [CARD] button indicator is lighted), no sound is output from the CARD MONITOR connectors; as a result, the CARD TRIM dial does not operate under this condition.

Card Mix Playback (*)

Loop playback of a single track on a memory card

Use this function for seamless loop mixing of a single track on the memory card with playback from a CD (CD-DA).

This operation is enabled when the source selector is set to CD (SOURCE SELECT [CD] button indicator is lighted).

1. Load a memory card with desired track into the player.

- The CARD indicator will light.
- MMC cards created on devices equipped with security functions, or MMC cards formatted using proprietary formats cannot be played (the CARD indicator will not light when the card is loaded).
- The player will search for the first track on the default playlist and enter cue pause mode at that point; the LOOP START/STOP button (right arrow and square) will simultaneously light.

2. Press the MIXOUT CARD CONTROL block's TRACK SEARCH button (left arrow, right arrow) to select the desired track onto the memory card.

- The track number will change up or down, corresponding to the direction indicated by the button pressed, and the track number and title of the first track discovered will be displayed; the player will enter cue pause mode at the beginning of the track.
- If the button is held depressed, the search will be performed continuously; if the button is held depressed for 2 seconds or more, the speed of search will increase.
- If reverse search (left arrow) is performed from the lowest numbered track, the search function will jump to the last (highest numbered) track.
- If forward search (right arrow) is performed from the highest numbered track, the search function will jump to the first (lowest numbered) track.
- To search within a specific play list of a memory card, use the FOLDER SEARCH button (left arrow, right arrow) first to designate the desired play list; in this way, the track search function will operate on the tracks in the selected play list. If no play list is designated, the search function will be performed within all tracks located in the memory card.
- During playback, to skip to the previous track, press the left arrow button twice in succession.

3. Press the LOOP START/STOP button (right arrow and square).

- When pressed from the cue pause mode, the button's [right arrow and square] indicator flashes and playback simultaneously begins.
- When the selected track ends, playback returns to the beginning of the track and begins again (seamless one-track loop).
- If the LOOP START/STOP button (right arrow and square) is pressed during playback, playback stops, the button's [right arrow and square] indicator lights and the unit enters the cue pause mode at the beginning of the track.
- By making cue and loop settings beforehand, you can change the range of the loop playback (see P.16).

Cue point sampler

When a memory card track has been set in the cue pause mode, this function plays the track only so long as the MIXOUT CARD CONTROL block's CUE button is held depressed.

This function operates when the source selector is set to CD (SOURCE SELECT [CD] button indicator is lighted). When card mix play is enabled, the MIXOUT CARD CONTROL block's [CUE] button indicator lights.

Press the CUE button in the MIXOUT CARD CONTROL block.

- Playback will continue as long as the button is held depressed; when the button is released, playback will stop and the player will return to the cue pause mode at the beginning of the track.
- By setting a cue point beforehand, you can make playback begin from the cue point when the CUE button is depressed; when the CUE button is released, playback will stop and the player will return to the cue pause mode at the selected cue point.

■ **CD and MEMORY CARD synchro playback**

Aligning the beats of two different tracks is a basic technique that DJs must master. To do this, the CARD TEMPO dial is rotated until the tempo of the memory card playback matches the beat of the currently playing CD; the DJ then presses the MIXOUT CARD CONTROL block's LOOP START/STOP button with the proper timing to align the two sources.

- While MIXOUT is turned OFF ([MIXOUT] button indicator is not lighted), no memory card sound is produced from the AUDIO OUT connectors. Leave the MIXOUT set to OFF while adjusting the memory card's tempo and practicing the start timing; when ready, set MIXOUT to ON and press the LOOP START/STOP button at the desired instant to overlay the memory card playback with the CD sound.
- If you fail to press LOOP START/STOP button with the correct timing, press the button again to stop memory card playback. The playback will enter cue pause mode at the beginning of the track (or at the CUE point if one has been set). When ready, press the LOOP START/STOP button to begin synchro card playback again.
- If the BPM of the two sources does not match perfectly, the tempo of the two will begin to deviate. To correct the deviation, either rotate the CARD TEMPO dial or move the TEMPO control slider. Use the displayed BPM value as a reference while relying on your own ears and sense of timing.
- This function does not automatically match the timing of different sources, so you can utilize advanced techniques such as deliberately playing back two sources out of synch.

■ **Measuring the BPM**

To assist when playing a track without a published BPM, the player automatically measures the BPM during playback. During measurement, the BPM indicator flashes, and when measurement is complete, the BPM indicator lights steadily. Measuring continues thereafter and the BPM value is automatically updated; if the unit is unable to measure the BPM value, the BPM indicator changes to a flashing display.

- BPM values are not written to CD-DA, so the BPM should be measured before beginning BPM synchro playback.
- When using the DJ software program "DJ Booth" to download tracks to an SD memory card, the BPM value measured with "DJ Booth" can be recorded beforehand on the CARD.
- In the event no BPM value is prerecorded on the SD memory card, it will be necessary to perform BPM measurement in the same way as for CD-DA.

■ **BPM Synchro Playback**

This function automatically matches the BPM of CD and memory card playback in accordance with the tempo rates of each source. BPM synchro can be used only when the BPM rates of each source are known and the difference between them is no more than $\pm 16\%$.

- This function automatically synchronizes the playback tempo of the memory card to that of the CD track. As a result, if the TEMPO control slider is used to change the playback speed of the CD, the memory card's playback speed will follow and change as well.
- Note, however, that the memory card's tempo can be adjusted within a maximum range of $\pm 16\%$. As a result, if the CD's TEMPO control slider is moved too much, the memory card's tempo may not be able to follow.
- In order to use BPM synchro playback, measurement of the BPM rates for the two sources must be completed. When playing a track whose BPM rate has been already written to the memory card, however, new BPM measurement is not required, so BPM synchro playback can be started merely by loading the card and selecting the desired track.
- By using the BPM synchro function, the DJ can devote his attention to adjusting the beat of the music.

The BPM synchro function defaults to OFF whenever the MIXOUT CARD CONTROL block's [SYNCHRO] button indicator is not lighted. When BPM synchro playback is enabled, the [SYNCHRO] button indicator flashes, but the memory card's playback speed remains as it was before (synchro function standby).

- If the SYNCHRO button is pressed while its indicator is flashing, the button indicator lights and BPM synchro playback begins (the memory card's playback speed changes to match that of the CD).
- During BPM synchro playback, press the SYNCHRO button to turn off the BPM synchro function (the button's indicator light also goes out). When this is done, the memory card's playback speed will stay the same, and will not return to its original state, thus allowing the CARD TEMPO dial to be rotated to change the speed as desired.
- During BPM synchro playback, the CARD TEMPO dial changes to operate as the PITCH BEND function. The tempo changes temporarily in accordance with the direction and amount the dial is rotated, but when the rotation is stopped, the playback speed returns to its previous value; this is a convenient function for adjusting slight deviations in beat.
- Even when BPM synchro function is set to OFF, if a different track is selected, the unit will enter the BPM synchro standby mode.

■ **BPM value input (BPM Edit function)**

The DJ program software "DJ Booth" has been designed to allow track BPM values to be recorded to an SD memory card. By using "DJ Booth" to play the tracks of a memory card and detect their BPM rates, those values can be recorded on the SD memory card at the same time as you copy the track to the card. However, the DMP-555's BPM synchro function will not operate properly if such copying is performed before the BPM rates have been detected, or if wrong BPM values have been recorded. In addition, the accuracy with which "DJ Booth" detects a track's BPM rate may not precisely match the DMP-555's detection accuracy, with the result that some fine tuning and adjustment may be necessary when using the BPM synchro function with CD playback.

To solve this problem, the DMP-555 has been provided with the ability to modify the individual track BPM values pre-recorded on SD memory cards, and record those new values on the card. This is the BPM Edit function.

- Since new data will be written to the memory card, the card's write-protect switch must be disabled before loading the card into the player.
- While the player is writing new data to the card, the slot indicator will flash above the card slot. **Never press the CARD EJECT button or disconnect power to the player while the indicator is flashing, since data may be destroyed or the card may become unusable.**

1. **Set the source selector to CARD (the SOURCE SELECT [CARD] button indicator lights), and begin playback of the track whose BPM you wish to modify.**

- When a BPM value has already been recorded for the track, the BPM value will be displayed immediately after playback begins.
- If no BPM value has been written to the card, or if the actually measured BPM value diverges greatly from the value previously recorded on the card, the characters on the BPM display will flash, indicating that the player is currently detecting the BPM value.
- To display the correct BPM value, move the TEMPO control slider to the center position so that the TEMPO display shows 0.0%.

2. **Hold the SYNCHRO button depressed for 2 seconds or more to enter the EDIT MODE.**

- The contents of the upper dot matrix display will change in the order [title] → EDIT MODE → BPM EDIT. The card playback bit rate / BPM display on the right side displays the BPM value recorded on the memory card, while lower BPM display displays the actually measured BPM.
- Playback may stop, but in that event, merely press the PLAY/PAUSE button to resume play. When no loop is specifically set in the EDIT MODE, playback automatically defaults to one-track loop playback. To modify the BPM value of another track, use the TRACK SEARCH buttons to select the new track.
- The BPM value of short tracks may not be measurable if the track has not been defined well. In this event, set LOOP IN and LOOP OUT points to produce correct loop playback audio (we recommend that the "DJ Booth" program's CREATE function be used to set up the track again).

ADVANCED OPERATIONS: CARD MIXING (dual mode)

3. Use the Jog dial or SEARCH button to change the BPM value appearing on the card playback bit rate/BPM display to the desired value.

- In the EDIT MODE, rotating the Jog dial will not change the playback speed.
- Each press of the **SEARCH** button is equivalent to incrementing or decrementing the tempo by 0.1 BPM. When the button is held depressed, the BPM value changes continuously.
- The possible range of BPM values is from a minimum of 10.0 to a maximum of 199.9. When playing a track to measure the BPM, use the values shown in the lower BPM display as a reference.

4. Press the SYNCHRO button to write the modified BPM data to the memory card.

- The new data is not written to the memory card until the **SYNCHRO** button is pressed. If the **SOURCE SELECT CD** button is pressed ([**CD**] button indicator lights), the player will cancel the EDIT mode and enter the CD mode. Even if the **SOURCE SELECT CARD** button is pressed, the unit will cancel the EDIT mode and return to the original CARD mode.

- While the player is writing new data to the card, the slot indicator will flash above the card slot. **Never press the CARD EJECT button or disconnect power to the player while the indicator is flashing, since data may be destroyed or the card may become unusable.**
- The upper dot-matrix display will show the flashing message “**REWRITING.**”

5. When the display’s REWRITING message changes to “COMPLETE,” the new data has been completely written to memory card, and the unit will return to the original CARD MODE.

COMPUTER-LINKED OPERATIONS

When a USB cable is used to link the Digital Media Player to a computer, the program software provided with the player can be installed to allow the player to be used for playback of music located on the computer, and the Digital Media Player can be used as a memory card writer.

For details, consult the operating instructions accompanying your software.

- This appliance cannot be used alone for writing to SD memory cards from a CD.

TROUBLESHOOTING

Incorrect operations can be mistaken as malfunctions. If you believe the unit is not operating correctly, consult the chart below. Sometimes incorrect operation may be due to a malfunction in another component. If the problem is not fixed, check the other components used with the player. If the problem still persists, contact your nearest Pioneer authorized service center or dealer for service.

Symptom	Cause	Remedy
Disc doesn't eject even when CD EJECT button (▲) is pressed.	<ul style="list-style-type: none"> Power plug is disconnected from outlet. The CD EJECT LOCK switch is set to the [LOCK] position. 	<ul style="list-style-type: none"> Connect plug to wall outlet. Go to pause mode or cue standby mode before pressing the CD EJECT button (▲). Set the CD EJECT LOCK switch to the [UNLOCK] position before pressing the CD EJECT button (▲).
Playback doesn't commence even when the disc is inserted.	<ul style="list-style-type: none"> The auto cue function is set to on. 	<ul style="list-style-type: none"> Hold down the TIME MODE/AUTO CUE button for 1 second or longer to turn off the A. CUE function.
Playback immediately stops when started. During playback, the player pauses or stops.	<ul style="list-style-type: none"> Disc is loaded upside down. Smudges on the disc, etc. 	<ul style="list-style-type: none"> Load the disc correctly with the label side UP. Clean the smudges from the disc and then play it again.
No sound is audible.	<ul style="list-style-type: none"> Output cables are connected incorrectly or are loose. Incorrect operation of audio mixer. Pin plugs and/or amplifier terminals are dirty. Player is in pause mode. 	<ul style="list-style-type: none"> Recheck connections. Refer to installation instructions. Check the settings of the audio mixer switches and sound volume controls. Clean away dirt. Press the PLAY/PAUSE button (▶/).
Sound is distorted, noise is output.	<ul style="list-style-type: none"> Incorrect connections. Pin plugs and/or amplifier terminals are dirty. Interference is being picked up from a TV set. 	<ul style="list-style-type: none"> Connect to audio mixer's LINE INPUT terminals. (Do not connect to MIC terminals.) Clean away dirt. Switch OFF TV set, move player away from TV set or plug the player into a separate outlet.
With certain discs, loud noise is produced or play stops.	<ul style="list-style-type: none"> Disc has a bad scratch or warp. Disc is extremely dirty. 	<ul style="list-style-type: none"> Replace disc. Clean disc.
When the auto cue function is set ON, track search is not finished.	<ul style="list-style-type: none"> If the sound muted portion between selections is long, searching time will be long. If the sound muted portion is recorded for about 10 seconds or more, playback will start without the auto cue function. 	<ul style="list-style-type: none"> Press TIME MODE/AUTO CUE button for more than 1 second to set the auto cue function OFF.
Back cue function cannot be carried out even though the CUE button is pressed in playback mode.	<ul style="list-style-type: none"> The Cue point is not set yet. The Digital Mode switch (DIGITAL OUT) is set to the [ON] position. 	<ul style="list-style-type: none"> Set the Cue point. (See page 14.) The Digital Mode switch (DIGITAL OUT) is set to the [OFF] position.
Pressing the LOOP OUT button does not start loop play.	<ul style="list-style-type: none"> No Cue points (start points) have been set. The Digital Mode switch (DIGITAL OUT) is set to the [ON] position. 	<ul style="list-style-type: none"> Set a Cue point. The Digital Mode switch (DIGITAL OUT) is set to the [OFF] position.
The Jog dial does not operate.	<ul style="list-style-type: none"> The Digital Mode switch (DIGITAL OUT) is set to the [ON] position. 	<ul style="list-style-type: none"> The Digital Mode switch (DIGITAL OUT) is set to the [OFF] position.
The Jog dial does not operate as desired.	<ul style="list-style-type: none"> Incorrect JOG MODE [CDJ/SCRATCH] is set. 	<ul style="list-style-type: none"> Press the SCRATCH button to set the desired JOG MODE [CDJ or SCRATCH].
DJ functions do not work.	<ul style="list-style-type: none"> The Digital Mode switch (DIGITAL OUT) is set to the [ON] position. 	<ul style="list-style-type: none"> The Digital Mode switch (DIGITAL OUT) is set to the [OFF] position.
The picture of the TV screen is fluctuated or FM broadcast is interfered with noise.	<ul style="list-style-type: none"> Interference is being picked up from the CD player. 	<ul style="list-style-type: none"> Turn off POWER switch of the player, or move the player away from the TV or tuner.
The disc is not rotating when power is ON.	<ul style="list-style-type: none"> The disc rotation stops automatically if no operation has been performed for 80 minutes or more in pause mode When the last track on the disc is over the disc stops rotating. 	<ul style="list-style-type: none"> Playback can be started by pressing the PLAY/PAUSE button (▶/). Press the CD EJECT button (▲) to eject the disc.

OTHERS: TROUBLESHOOTING

- Static electricity and other external effects may cause this unit to malfunction. In this case, set the **POWER** switch to OFF, then switch it on again after the disc has come to a complete stop.
- This unit cannot playback unfinalized (partial discs) CD-R or CD-RW discs.
- This component is designed to play 12cm discs and 8cm discs with a commercially available adaptor, eccentrically shaped discs cannot be played since damage or malfunction may result.
- The BPM value measured by the DMP-555 may differ from the BPM value recorded on a CD or from our DJ mixer, but this difference is a result of differences in the BPM value measurement method; not a result of a fault with the player.

Error Message Display

When the DMP-555 player is unable to operate properly, an error code is displayed on the display panel. Check the error code displayed against the following table and take the recommended action to correct the error. If an error code other than any of the error codes listed in the table below is displayed or if the same error code is displayed even after corrective action has been taken, contact your nearest Pioneer Service Station or contact the store from which you purchased your player for assistance.

CD PLAYER ERROR

Error code	Description	Possible cause and first aid
E-7201	TOC READ ERROR	Disc is dirty. Disc has a crack. Player cannot recognize that disc. → Please try on another disc. If player does well, a cause is in that disc.
E-8301	START UP ERROR	
E-8302	PLAYBACK ERROR	
E-9101	MECHANICAL TIME OUT	Disc loading/unloading mechanism is out of order. → If a disc is still in the inside of the player, please turn off a power first and carry out forcible ejection of the disc (See page 5).

CARD ERROR/CAUTION

Message	Description	Possible cause
ERROR	There is something wrong.	Card is broken.
FULL	This card is full of data.	This card has no or enough space to write/record.
NO CARD	There is no card available.	Card is not inserted correctly. Card detection switch is broken.
NO TITLE	There is no valid title information.	Title has not been written. Title is written in two-byte character format.
NO TRACK	There is no track available.	That card is new one and there has been no download operation done. Download operation failed. All of the downloaded tracks are unsupported format. Current Playlist is empty.
NOT SDCARD	This card is not an SD memory card.	MultiMediaCards are able to be played but not able to write/record. The card is another type of the SD memory card family. The card is broken.
PROTECTED	This card is protected from rewriting.	Write-protect switch of the card is locked. The card is a Read-only type memory card.
READ ERROR	It is impossible to continue to read.	Data in the card is broken.
TOO SHORT	This track is too short to loop-play.	The length of the track is shorter than the length of one beat. That track is made for CUE sampling stuff. Detected BPM value is too small by miscounting.
UNFORMAT	This card has not been formatted.	The card had been formatted uncorrectly.
UNKNOWN	Artist is unknown. Album title is unknown.	There is no valid artist name for the track. There is no valid album name for the track.

CD-ROM ERROR/CAUTION

Message	Description	Possible cause
ERROR	There is something wrong.	Disc is broken.
NO TITLE	There is no valid title information.	Title has not been written. Title is written in two-byte character format.
NO TOC	TOC read error or there is no TOC.	This disc is not finalized. There is something wrong in the TOC.
NO TRACK	There is no track available.	That CD-R/RW is new one and there has been no writing operation done. All of the written tracks are unsupported format. Current folder is empty.
NOT CD-DA	This CD is not CD-DA.	Only CD-DA is able to be played in Digital-Out mode.
NOT CLOSED	The session is not closed.	The session of this disc is not closed. This disc is not finalized.
READ ERROR	It is impossible to continue to read.	Data on the disc is broken.
UNKNOWN	Artist is unknown.	There is no valid artist name for the track.
UNTITLED	Album is untitled.	There is no valid album name for the track.

OTHER ERROR/CAUTION

Message	Description	Possible cause
D-OUT-ON	Digital-Out mode is ON	That operation is not allowed during the Digital-Out mode is ON.
CD LOCKED	CD is locked from ejecting.	Eject Lock switch is active and the disc is not able to eject during playing.
REWRITING	SD memory card is busy rewriting itself.	Data in the SD memory card is now being rewritten (in the BPM-EDIT mode).
WRITING	SD memory card is busy writing itself.	Files are being downloaded to the SD memory card (in the PC mode). SD memory card is being reformatted now (in the PC mode).

SPECIFICATIONS**■ CD Player**

Type Compact disc player audio system
 Frequency response 4 Hz - 20 kHz
 SN ratio 102 dB or more (EIAJ)
 Distortion 0.003 % (EIAJ)

■ SD Memory Card

Data format SD audio format
 Corresponding compression type MP3
 Corresponding Bit rate 64 Kbps - 320 Kbps
 Corresponding sampling rate 44.1 kHz, 48 kHz, 32 kHz
 Copyright protection CPRM (SDMI compliant)

■ External interface

Computer interface USB 1.1

■ Miscellaneous

Power AC 120 V, 60 Hz
 Power Consumption 30W
 Operating temperature +5°C - +35°C
 Operating humidity 5-85% RH (without condensation)
 Weight 3.1 kg
 Dimensions 250 (W) x 360 (D) x 103.5 (H) mm

■ Accessories

● Operating Instructions	1
● Audio cables	2
● Control cord	1
● USB cable	1
● Forced ejection pin (found on bottom surface of player)	1
● SD memory card	1
● DJ application software (CD-ROM)	1
● Warranty	1

NOTE:

Specifications and design are subject to possible modification without notice.



Dear Customer:

Selecting fine audio equipment such as the unit you've just purchased is only the start of your musical enjoyment. Now it's time to consider how you can maximize the fun and excitement your equipment offers. This manufacturer and the Electronic Industries Association's Consumer Electronics Group want you to get the most out of your equipment by playing it at a safe level. One that lets the sound come through loud and clear without annoying blaring or distortion-and, most importantly, without affecting your sensitive hearing.

Sound can be deceiving. Over time your hearing "comfort level" adapts to higher volumes of sound. So what sounds "normal" can actually be loud and harmful to your hearing. Guard against this by setting your equipment at a safe level BEFORE your hearing adapts.

To establish a safe level:

- Start your volume control at a low setting.
- Slowly increase the sound until you can hear it comfortably and clearly, and without distortion.

Once you have established a comfortable sound level:

- Set the dial and leave it there.

Taking a minute to do this now will help to prevent hearing damage or loss in the future. After all, we want you listening for a lifetime.

We Want You Listening For A Lifetime

Used wisely, your new sound equipment will provide a lifetime of fun and enjoyment. Since hearing damage from loud noise is often undetectable until it is too late, this manufacturer and the Electronic Industries Association's Consumer Electronics Group recommend you avoid prolonged exposure to excessive noise. This list of sound levels is included for your protection.

Decibel

Level	Example
30	Quiet library, soft whispers
40	Living room, refrigerator, bedroom away from traffic
50	Light traffic, normal conversation, quiet office
60	Air conditioner at 20 feet, sewing machine
70	Vacuum cleaner, hair dryer, noisy restaurant
80	Average city traffic, garbage disposals, alarm clock at two feet.

THE FOLLOWING NOISES CAN BE DANGEROUS UNDER CONSTANT EXPOSURE

90	Subway, motorcycle, truck traffic, lawn mower
100	Garbage truck, chain saw, pneumatic drill
120	Rock band concert in front of speakers, thunderclap
140	Gunshot blast, jet plane
180	Rocket launching pad

Information courtesy of the Deafness Research Foundation.



Should this product require service in the U.S.A. and you wish to locate the nearest Pioneer Authorized Independent Service Company, or if you wish to purchase replacement parts, operating instructions, service manuals, or accessories, please call the number shown below.

800 - 872 - 4159

Please do not ship your product to Pioneer without first calling the Customer Support Division at the above listed number for assistance.

**Pioneer Electronics (USA) Inc.
Customer Support Division
P.O. BOX 1760, Long Beach,
CA 90801-1760, U.S.A.**

For warranty information please see the Limited Warranty sheet included with your product.

Should this product require service in Canada, please contact a Pioneer Canadian Authorized Dealer to locate the nearest Pioneer Authorized Service Company in Canada. Alternatively, please contact the Customer Service Department at the following address:

**Pioneer Electronics of Canada, Inc.
Customer Satisfaction Department**

**300 Allstate Parkway
Markham, Ontario L3R OP2
(905) 479-4411
1 (877) 283-5901**

For warranty information please see the Limited Warranty sheet included with your product.

Supply of this product only conveys a license for private, non-commercial use and does not convey a license nor imply any right to use this product in any commercial (i.e. revenue-generating) real time broadcasting (terrestrial, satellite, cable and/or any other media), broadcasting/streaming via internet, intranets and/or other networks or in other electronic content distribution systems, such as pay-audio or audio-on-demand applications. An independent license for such use is required. For details, please visit <http://www.mp3licensing.com>.



Fraunhofer Institut
Integrierte Schaltungen

MPEG Layer-3 audio coding technology licensed from Fraunhofer IIS and Thomson multimedia

"Recording equipment and copyright: Recording equipment should be used only for lawful copying and you are advised to check carefully what is lawful copying in the country in which you are making a copy.

Copying of copyright material such as films or music is unlawful unless permitted by a legal exception or consented to by the rightowners."

- The SD logo is a trademark.
- Portions of this product are protected under copyright law and are provided under license by ARIS/SOLANA/4C.

Published by Pioneer Corporation.
Copyright © 2002 Pioneer Corporation.
All rights reserved.

PIONEER CORPORATION 4-1, Meguro 1-Chome, Meguro-ku, Tokyo 153-8654, Japan

PIONEER ELECTRONICS (USA) INC.

Multimedia and Mass Storage Division: 2265 East 220th Street, Long Beach, CA 90810, U.S.A. TEL: 800-444-OPTI (6784)

PIONEER ELECTRONICS OF CANADA, INC.

Industrial Products Department: 300 Allstate Parkway, Markham, Ontario L3R OP2, Canada TEL: 905-479-4411