

Husqvarna Outdoor Products Italia SpA
Via Como, 72
23868 Valmadrera LC
ITALIA
Phone +39 0341 203111 - Fax +39 0341 581671

PN 249955 REV. 00 (10/06)



GB	INSTRUCTION MANUAL IMPORTANT INFORMATION: Please read these instructions carefully and make sure you understand them before using this unit. Retain these instructions for future reference.	IT	LIBRETTO D'ISTRUZIONI INFORMAZIONI IMPORTANTI: Leggere le istruzioni attentamente e capirle bene prima di usare l'utensile. Conservare per ulteriore consultazione.
DE	BETRIEBSANWEISUNG WICHTIGE INFORMATION: Lesen Sie diese Hinweise zur Handhabung des Geräts aufmerksam durch. Verwenden Sie es erst, wenn Sie sicher sind, daß Sie alle Anweisungen verstanden haben und gut aufbewahren.	HU	HASZNÁLATI ÚTMUTATÓ Jótállást vállalni csak rendeltetésszerűen használatba vett gépekre tudunk. Kérj ú hogy a gép használatba vétele előtt gondosan olvassa el a kezelési utasításokat.
FR	MANUEL D'INSTRUCTIONS RENSEIGNEMENTS IMPORTANTS: Avant d'utiliser cet appareil, veuillez lire attentivement les instructions et assurez-vous de les avoir comprises. Conservez les instructions pour référence ultérieure.	GR	ΕΓΧΕΙΡΙΔΙΟ ΧΕΙΡΙΣΜΟΣ ΣΗΜΑΝΤΙΚΕΣ ΠΛΗΡΟΦΟΡΙΕΣ: Διαβάστε προσεκτικά αυτές τις οδηγίες και φροντίστε να τις κατανοήσετε αυτό το μηχάνημα και φυλάξτε το για να το συμβουλευέστε στο μέλλον.
NL	HANDLEIDING BELANGRIJKE IMPORTANTS: Lees deze handleiding aandachtig en zorg dat u alles begrijpt alvorens de kettingzaag te gebruiken en be-waar ze voor toekomstige raadpleging.	CZ	NÁVOD K POUŽÍVÁNÍ DŮLEŽITÁ INFORMACE! Než začnete stroj používat přečtěte si prosím velmi pozorně tyto instrukce a ujistěte se, že jste jim porozuměli. Uchovejte si tento návod pro použití i v budoucnu.
NO	BRUKERHÅNDBOK VIKTIG INFORMASJON: Les disse anvisningene nøye og forsikre deg om at du forstår dem før du bruker enheten og oppbevar dem for sen-ere bruk.	PL	INSTRUKCJA OBSŁUGI Gwarancja traci ważność w przypadku użycowania urządzenia do celów innych niż wymienione w instrukcji obsługi. Prosimy o uważne przeczytanie instrukcji oraz o stoowanie się do zaleceń i wskazówek w niej zawartych.
FI	OHJEKIRJA TÄRKEÄÄ TIETOA: Lue nämä ohjeet huolellisesti ja varmista, että olet ymmärtänyt ne, ennen kuin alat käyttää tätä laitetta ja säilytä myöhempää tarvetta varten.	SK	NÁVOD NA OBSLUHU Dôležitá informácia: Pred použitím stroja si starostlivo prečítajte tento návod na obsluhu a uistite sa že ste mu dôkladne porozumeli. Návod starostlivo uschovajte pre potrebu v budúcnosti.
SE	BRUKSANVISNING VIKTIG INFORMATION: Läs instruktionerna noggrant och försäkra dig om att du förstår dem innan du använder utrustningen och spara dem för framtida behov.	RU	ИНСТРУКЦИИ ВАЖНЫЕ СВЕДЕНИЯ: Внимательно прочитайте инструкции и хорошо их понять, перед тем как пользоваться блоком. Хранить инструкции для дальнейших консультаций.
DK	BRUGERHÅNDBOG VIGTIGE OPLYSNINGER: Læs instruktionerne omhyggeligt, før du bruger enheden og gemme til senere henvisning.	EE	KASUTUSJUHEND TÄHTIS INFORMATSIOON: Lugege kasutusjuhend enne seadme kasutamist kindlasti põhjalikult läbi ning veenduge, et olete kõigest täpselt aru saanud.
ES	MANUAL DE INSTRUCCIONES INFORMACIÓN IMPORTANTE: Lea atentamente las instrucciones y asegúrese de entenderlas antes de utilizar esta aparato. Conserve las instrucciones para la referencia en el futuro.	LV	ROKASGRĀMATA SVARĪGA INFORMĀCIJA: Pirms ierīces izmantošanas izmanīgi izlasiet rokasgrāmatu un pārliecinieties, ka jūs abi saprotat tās saturu. Saglabājiet rokasgrāmatu, lai nākotnē būtu iespējams atsvaidzināt jūsu zināšanas.
PT	MANUAL DO OPERADOR INFORMAÇÕES IMPORTANTES: Queira ler cuidadosamente estas instruções e tenha certeza de entendê las antes de usar a serra e guarde para consulta futura.	TR	KULLANMA KYLAVUZU ÖNEMLİ TALİMATLAR: Buradaki bilgileri dikkatlice okuyunuz ve aletii kullanmaya başlamadan önce tüm talimatların taratınızd anlaşılmış olduğundan emin olunuz. Gerektiği zaman başvurabilmemiz için saklayınız.

GB Due to a constant product improvement programme, the factory reserves the right to modify technical details mentioned in this manual without prior notice.

DE Im Sinne des Fortschritts behält sich der Hersteller das Recht vor, technische Änderungen ohne vorherigen Hinweis durchzuführen.

FR La Maison se réserve la possibilité de changer des caractéristiques et des données de ce manuel à n'importe quel moment et sans préavis.

NL Door konstante produkt ontwikkeling behoud de fabrikant zich het recht voor om technische specificaties zoals vermeld in deze handleiding te veranderen zonder hiervan vooraf bericht te geven.

NO Produsenten forbeholder seg all rett og mulighet til å forandre tekniske detaljer i denne manualen uten forhåndsvarsel.

FI Jatkuvan tuotteen parannusohjelman tähden valmistaja pidättää oikeuden vaihtaa ilman ennakkovaroitusta tässä ohjekirjassessa mainittuja teknisiä yksityiskohtia.

SE Tilverkaren reserverar sig rätten att ändra fakta och uppgifter ur handboken utan förvarning.

DK Producenten forbeholder sig ret til ændringer, hvad angår karakteristika og data i nærværende instruktion, når som helst og uden varsel.

ES La firma productora se reserva la posibilidad de cambiar las características y datos del presente manual en cualquier momento y sin previo aviso.

PT A casa productora se reserva a possibilidade de variar características e dados do presente manual em qualquer momento e sem aviso prévio.

IT La casa produttrice si riserva la possibilità di variare caratteristiche e dati del presente manuale in qualunque momento e senza preavviso.

HU A gyártó cég fenntartja a jogot arra, hogy a használati utasításban megadott adatokon és technikai tulajdonságokon bármikor és előzetes bejelentés nélkül változtasson.

GR Λόγω προγράμματος συνεχοῦς βελτίωσης προϊόντων, το εργοστάσιο επιφυλάσσεται του δικαιώματος να τροποποιεί τις τεχνικές λεπτομέρειες που αναφέρονται στο εγχειρίδιο αυτό χωρίς προηγούμενη ειδοποίηση.

CZ Vzhledem k pokračujícím inovacím si výrobce vyhrazuje právo měnit technické hodnoty uvedené v této příručce bez předchozího upozornění.

PL W związku z programem ciągłego ulepszania swoich wyrobów, producent zastrzega sobie prawo do wprowadzania zmian w szczegółach technicznych wymienionych w tej instrukcji bez uprzedniego zawiadomienia. Instrukcja jest częścią wyposażenia

SK Proizvavalec si pridržuje pravico, da spremeni značilnosti in podatke pričujočega priročnika v katerem koli trenutku in brez predhodnega obvestila.

RU Компания производитель сохраняет за собой право изменять характеристики и данные в настоящем руководстве, в любой момент и без предварительного извещения.







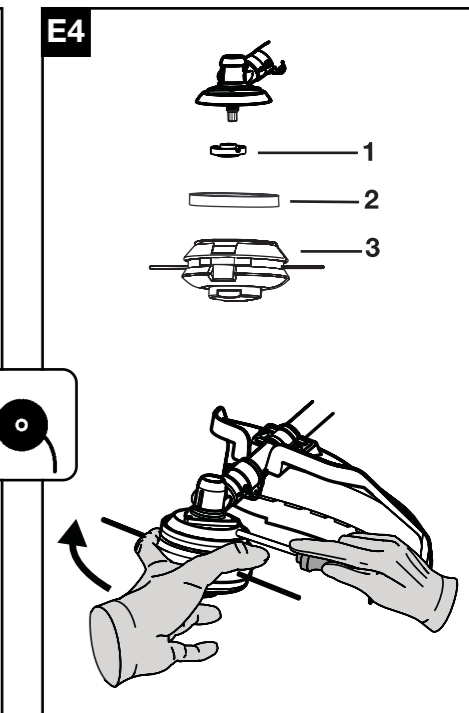
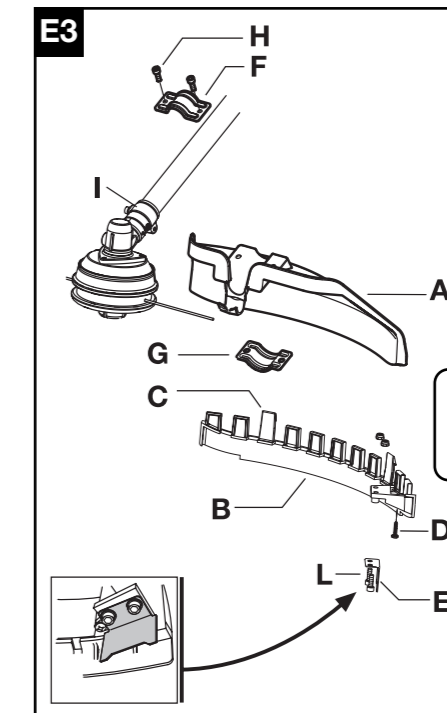
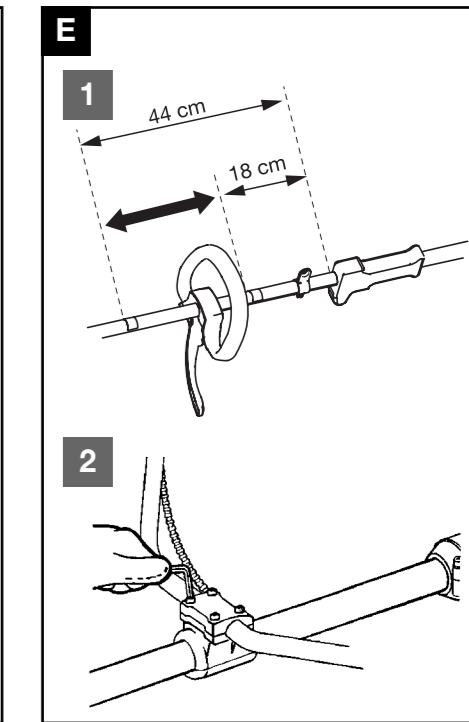
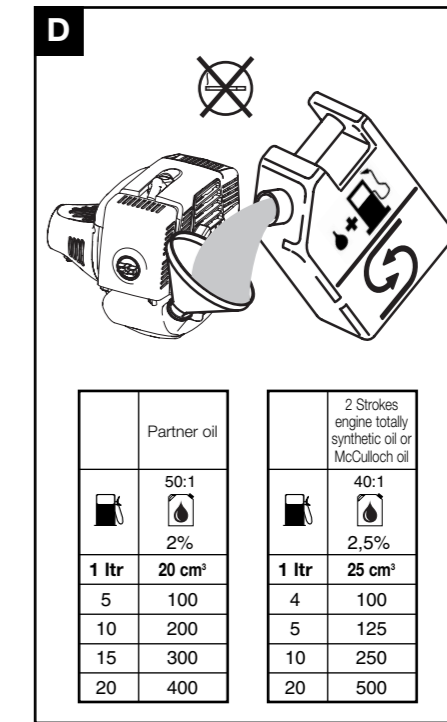
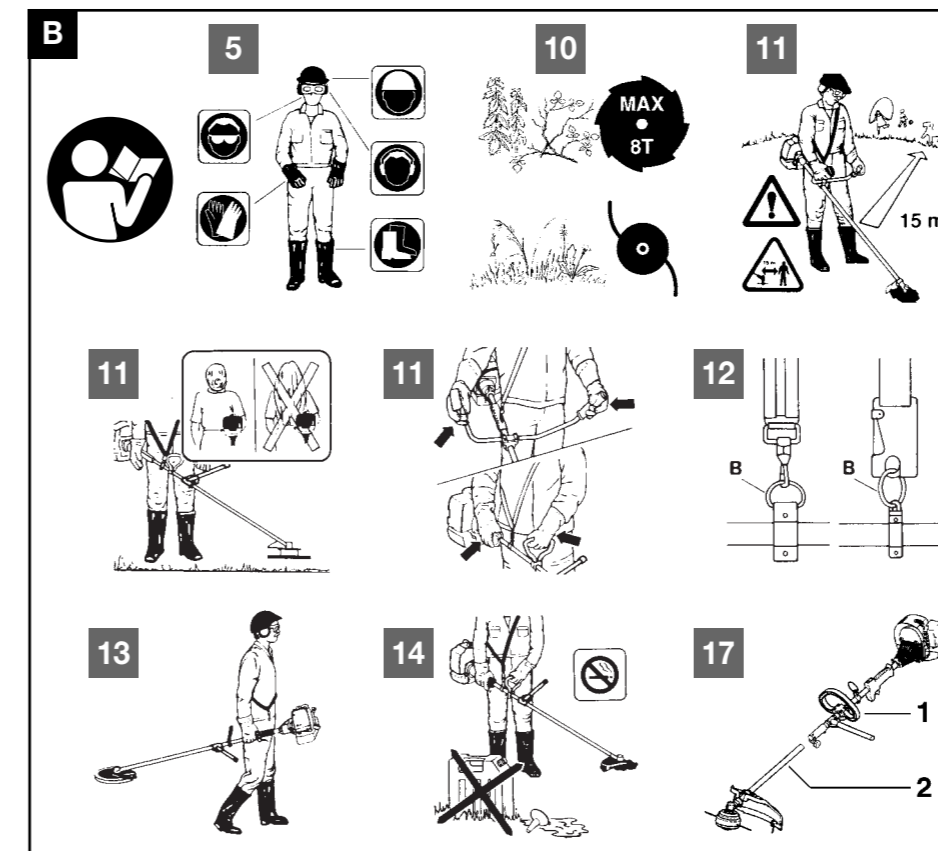
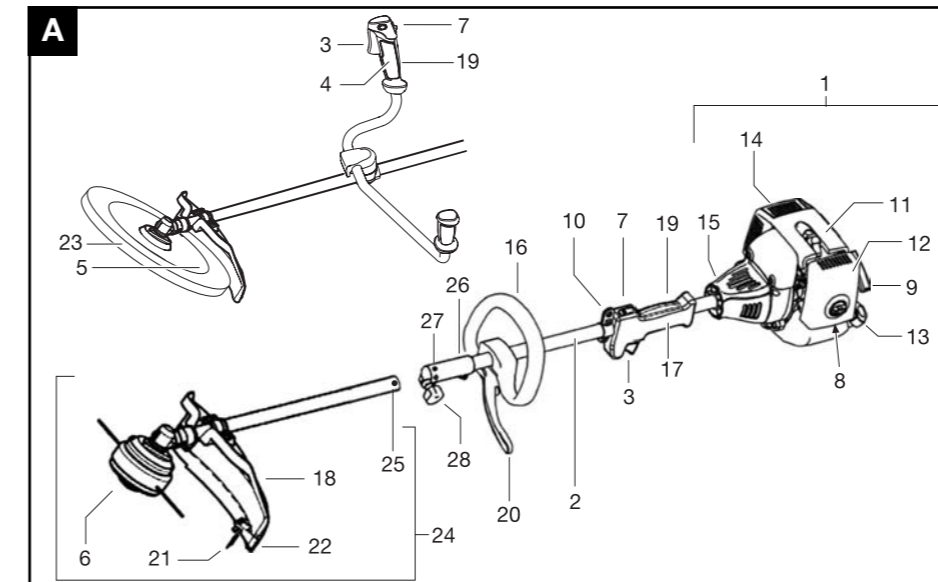

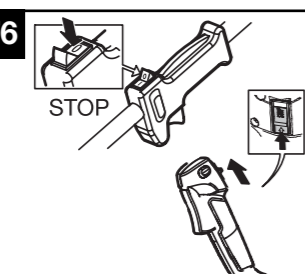
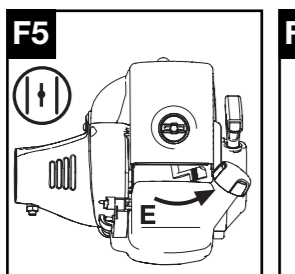
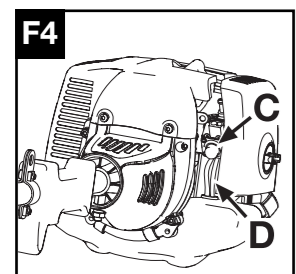
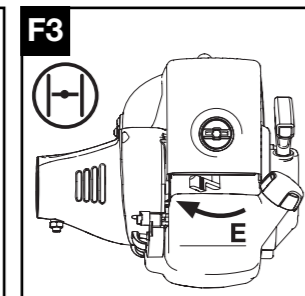
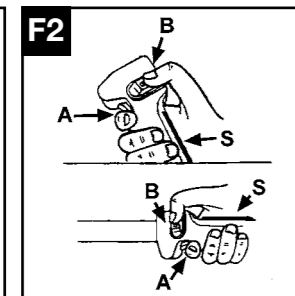
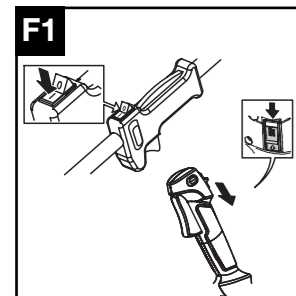
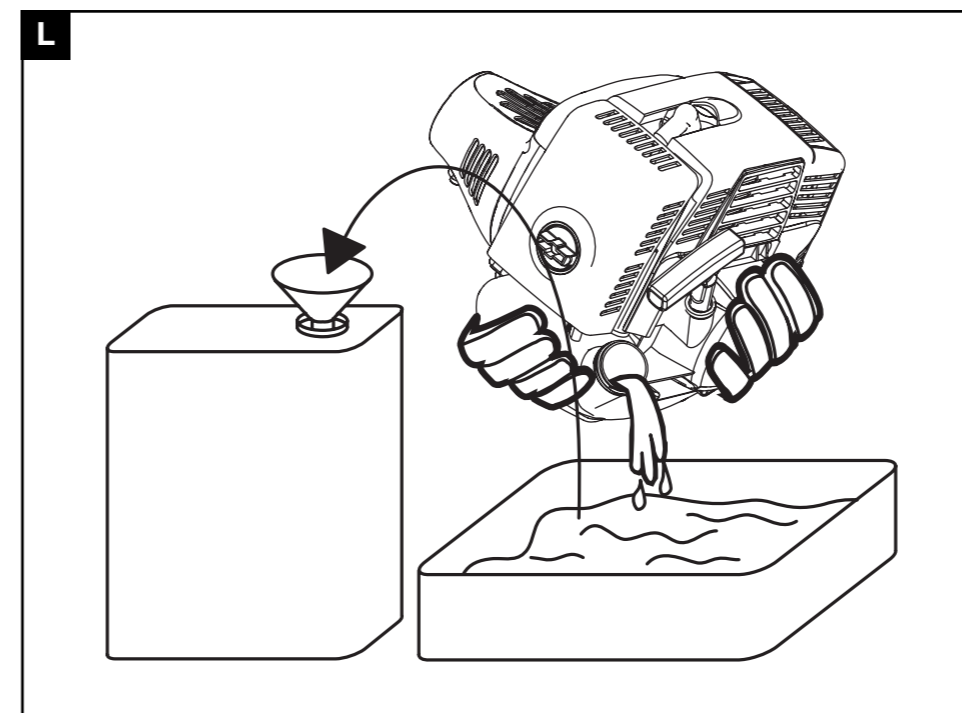
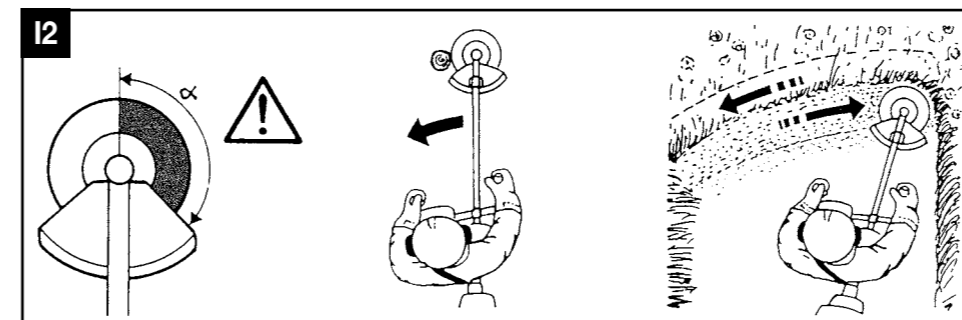
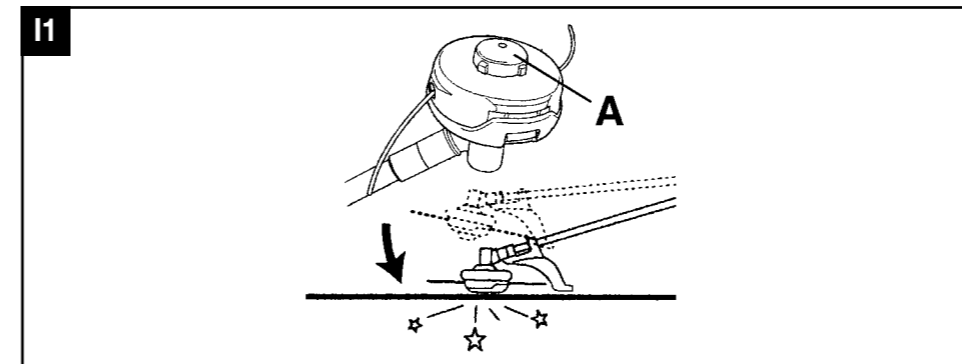
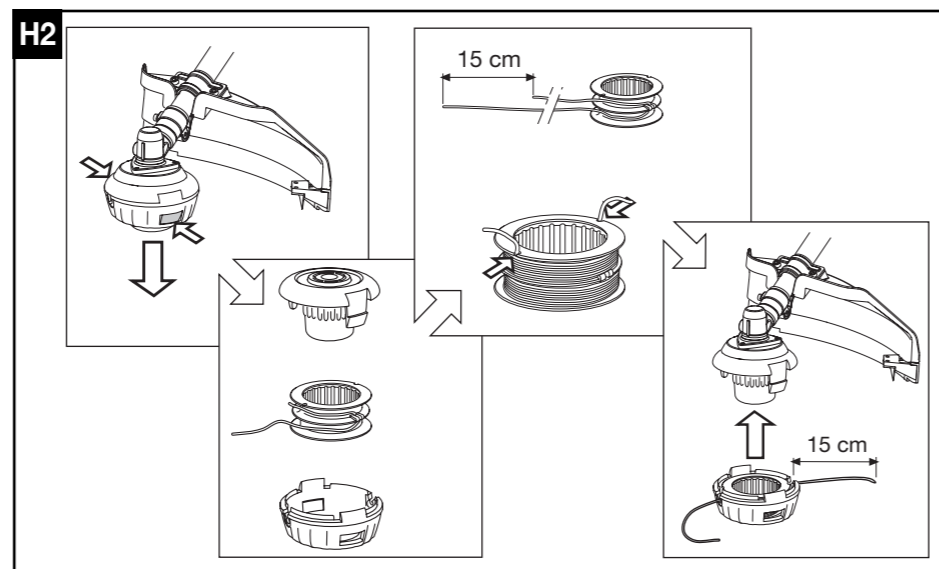
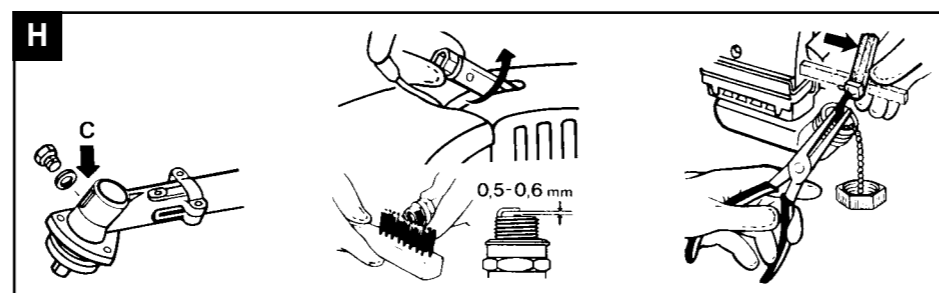
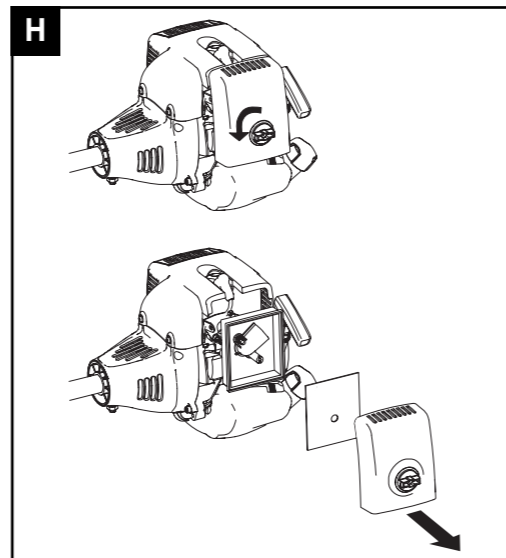
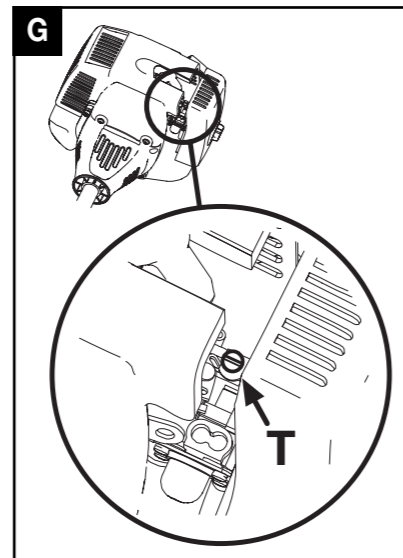
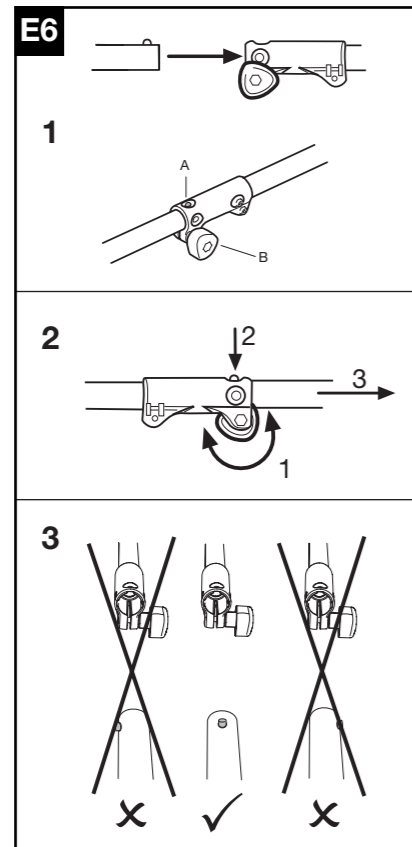
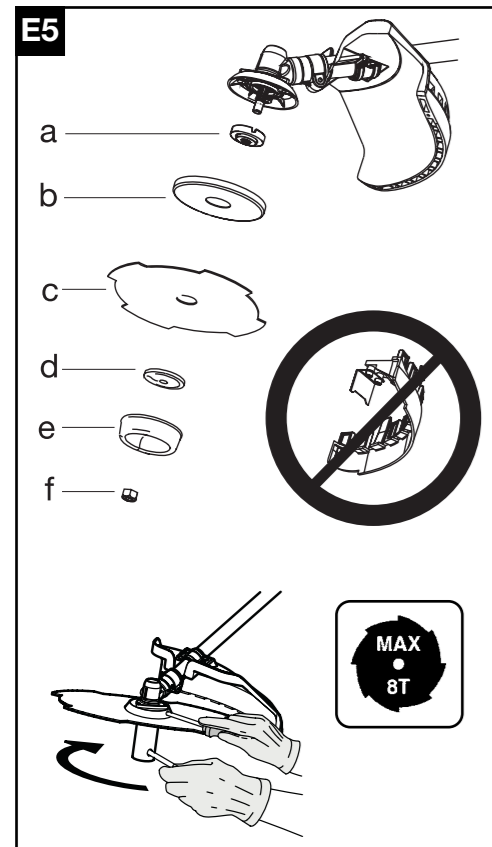

EE Tootja jätab endale õiguse muuta käesolevas kasutusjuhendis kirjeldatud omadusi ja andmeid suvalisel hetkel ja sellest eelnevalt ette teatamata.

LV Izgatavotājs saglabā tiesības jebkurā brīdī un bez brīdinājuma mainīt šajā rokasgrāmatā esošos datus un raksturlielnes.

TR Üretici firma bu kullanma kılavuzunda yer alan özellik ve verilerin istediği zamanda ve haber vermeksizin değiştirilme hakkını kendinde sahip tutar.





		34/40 cc	
0,095" 2.4mm		197" 5000mm	531025001
			538249155
4T		9" 230 mm	531024905
			538249155
4T		10" 255 mm	531024902
			538249155
8T		9" 230mm	531024906
			538249155
8T		10" 255mm	531024903
			538249155

- GB** SUMMARY CHART TO IDENTIFY THE CORRECT GUARD NEEDED, WITH DIFFERENT CUTTING ATTACHMENTS
- DE** ÜBERSICHTSTABELLE ZUR AUSWAHL DES RICHTIGEN SCHUTZBLECHES FÜR DIE EINZELNEN SCHNEIDWERKZEUGE
- FR** TABLEAU RECAPITULATIF POUR LE CORRECT ACCOUPLEMENT LAME OU TÊTE FIL NYLON / DEFENSE DE SECURITE
- NL** OVERZICHTSTABEL OM TE BEPALEN WELKE BESCHERMKAP GEBRUIKT MOET WORDEN BIJ DE DIVERSE MAAI-ONDERDELEN
- NO** TABELL FOR KORREKT MONTERING AV TRÅD-SPOLE/SAGBLAD OG SPRUTSKJÆRM/SIKKERHETSVÆRN
- FI** TAULOKKO LEIKKAAVAN PÄÄN/TURVASUOJUKSEN OIKEASTA YHDISTELMÄSTÄ
- SE** SAMMANFATTANDE TABELL ÖVER KORREKT KOMBINATION AV SKÄRHUVUD/SÄKERHETSSKYDD
- DK** OVERSIGTSTABEL VEDRØRENDE DEN KORREKTE SAMMENSÆTNING AF KNIV OG BESKYTTELSESSKÆRM
- ES** TABLA PARA EL CORRECTO ACOPLAMIENTO DE LA CABEZA CORTANTE Y PROTECTOR DE SEGURIDAD
- PT** TABELA DE RESUMO PARA A CORRETA APLICAÇÃO DA CABEÇA CORTANTE E DEFESA DE SEGURANÇA
- IT** TABELLA RIASSUNTIVA PER IL CORRETTO ABBINAMENTO TESTA TAGLIANTE / DIFESA DI SICUREZZA
- HU** ÖSSZEFOGLALÓ TÁBLÁZAT: A NYÍRÓFEJ ÖSSZEÁLLÍTÁSA / BALESETVÉDELEM
- GR** ΠΕΡΙΛΗΠΤΙΚΟΣ ΠΙΝΑΚΑΣ ΓΙΑ ΤΗΝ ΕΠΙΣΗΜΑΝΣΗ ΤΟΥ ΚΑΤΑΛΛΗΛΟΥ ΠΡΟΦΥΛΑΚΤΗΡΑ, ΜΕ ΔΙΑΦΟΡΑ ΚΟΠΤΙΚΑ ΕΞΑΡΤΗΜΑΤΑ
- CZ** SHRNUJÍCÍ TABULKA PRO SPRÁVNOU KOMBINACI REZNÁ HLAVA/BEZPEČNOSTNÍ OCHRANA
- PL** TABELA ZBIORCZA POPRAWNEGO ZESTAWIENIA GŁOWICY TNAŹEJ / OSŁONY ZABEZPIEZAJĄCEJ
- SK** TABELA - POVZETEK ZA PRAVILNO POVEZAVO GLAVA/ ZASČITA
- RU** ОБЗОРНАЯ ТАБЛИЦА ДЛЯ ПРАВИЛЬНОГО СОЧЕТАНИЯ РЕЖУЩЕЙ ГОЛОВКИ / ПРЕДОХРАНИТЕЛЬНОГО УСТРОЙСТВА
- EE** KOKKUVÕTLIK TABEL TRIMMIPEEA JA SELLE KAITSME KORREKTSEKS MONTEERIMISEKS
- LV** NOSLĒGUMA TABUĻA PAREIZAI GRIEŠANAS GALVIŅAS UN DROŠĪBAS AIZSARGA SAVIENOŠANAI
- TR** DOĞRU BİR GİYİM ŞEKLİ İÇİN ÖZETLEYİCİ TABELA KESİCİ KAFA / EMNİYET KORUNMASI

A. General description

- 1) ENGINE
- 2) SHAFT
- 3) THROTTLE TRIGGER
- 4) RIGHT CONTROL HANDLE
- 5) BLADE
- 6) NYLON STRING HEAD
- 7) STOP SWITCH
- 8) CHOKE
- 9) STARTER HANDLE
- 10) HARNESS RING
- 11) SPARK PLUG
- 12) AIR FILTER COVER
- 13) FUEL TANK CAP
- 14) MUFFLER SHIELD
- 15) ENGINE/SHAFT JOINT
- 16) DELTA HANDLE
- 17) REAR CONTROL GRIP
- 18) SAFETY GUARD
- 19) SAFETY LEVER
- 20) SAFETY POLE GUARD
- 21) STRING CUTTER BLADE
- 22) NYLON STRING HEAD GUARD EXTENSION
- 23) BLADE GUARD
- 24) ATTACHMENT
- 25) LOCKING PIN
- 26) SHAFT / ATTACHMENT JOINT
- 27) LOCKING PIN HOUSINGS
- 28) JOINT KNOB

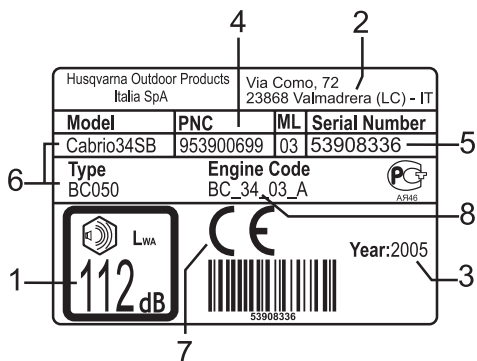

Example of identification label

LEGEND:

- 1) Guaranteed noise level according to directive 2000/14/EC
- 2) Manufacturer's name and address
- 3) Year of manufacture
- 4) Product code
- 5) Serial no.
- 6) Model/type
- 7) CE marking of conformity
- 8) Displacement

B. Safety precautions

Explanation of Symbols



Warning



Safety apparel: Approved boots.



Safety apparel: Approved protective goggles or visor, approved hard hat and hearing protection.



Do not smoke when refueling or using the machine.



Read the instructions for the user carefully and make sure you understand how all the controls work.



Choke



Safety apparel: Approved gloves.



Danger of flying debris.



Minimum safety distance 15m.



Emergency stop.



Maximum shaft speed.



Danger of kickback. The blade is capable of amputating arms and legs.



CAUTION! Danger of serious leg injuries. Take scrupulous care to follow the instructions in the manual.



CAUTION! The cutting parts and muffler may get very hot and cause burns. Wait a w minutes before touching them.

Use of the manual

- Anyone who uses the machine should have read the entire manual with extreme care.
- All users should be familiar with the operations for use of the machine under absolutely safe conditions as described in this manual, and should be instructed in the proper cutting techniques to use, possibly by practical demonstration.
- Do not allow children or persons who are not familiar with these instructions and are not sufficiently trained to use the brush cutter. Local regulations may specify an age limit for users.
- Keep this manual with the machine when selling or lending it, to enable the future users to familiarize themselves with the product and instructions for safe use.
- All parts of the manual are equally important for the purpose of preventing injury to the operator or damage to the machine. To facilitate your reading, section B is divided into parts that can be called up in the rest of the manual, marked with the "CAUTION" symbol followed by the number of the corresponding paragraph, to concentrate your attention on the main safety procedures related to a particular situation.

Prior to use

- Respect of the procedures described in this manual does not eliminate the risks of accidents but does reduce the probability of their occurring or the effect of the damage.
- If you have never used a brush cutter before, practice using it for a while before actually starting to work with it.
- The operator or user is responsible for any damages to third parties or their property, and for any dangers to which they may be subject.
- Do not use this machine for any other purpose than that for which it was designed, using the proper cutting devices as indicated in the instructions.
- Do not use the machine if you are tired, in poor health or under the effects of alcohol or medication that could affect your reactions.
- Make sure you know how to stop the engine and blade if necessary (see section entitled "Starting and stopping the engine").

Make sure the machine is correctly assembled, and all its parts are working properly. Make sure the screws are all in place and securely tightened. Check operation of the accelerator control block and make sure there is no leakage of fuel. Check that the cutting tool does not move with the motor running at idle speed. Make sure the transmission pipe is properly fastened to the motor joint and the line cutter head or blade are correctly fastened with the screw fastening the blade fully tightened.

2 Replace any accessories (blades, nylon string heads, guards) which show damage or cracks or appear excessively worn. Have your Authorized Service Center replace any damaged parts. For nylon string heads, use only strings made of flexible material recommended by the manufacturer. For example, you should never use metal wire because it could cause serious injuries to people, property and animals. An unsuitable string could break and turn into a very dangerous missile. In mounting the cutting utensils follow the instructions in the chapter entitled "Usable cutting tools and their installation on the machine". **ABSOLUTELY DO NOT USE THE BRUSH CUTTER IF THE SPECIFIC SAFETY GUARD FOR THE CUTTING DEVICE IN USE IS NOT SECURELY FASTENED** (see chapter "Assembly/disassembly"). Failure to follow this rule can expose you to serious danger such as:

- possible contact with rotating and cutting parts;
- possible contact with flying debris.

Never use a brush cutter without its safety pole guard correctly in place. Only use blades or nylon string heads clearly marked with a maximum speed of at least 10,500 min⁻¹.

3 Use only original or approved accessories and spare parts, which you can purchase from our official distributors. The use of other accessories and spare parts increases the danger of injury and in this case the manufacturer has no liability for damage to persons or property. Never attempt to use the machine if it is incomplete, defective or has been altered by anyone other than an Authorized Service Center. The risk of accidents increases considerably if maintenance is not carried out regularly in a professional way. In case of doubt contact an authorized service center.

- 1** Inspect the machine carefully before every use, in case of violent impact or signs of malfunction.

- 4** All operations of maintenance, assembly, disassembly and fueling should be done with the

machine on a flat, solid surface so that the motor cannot turn over, in a stable position with the motor off, the switch turned to O/STOP, the cutting tool stopped and wearing adequate protective gloves.

Apparel

5 Dress suitably for the job; wear approved personal protection gear:

- Closely fitting protective clothing (do not wear shorts or loose clothing). Do not wear jewelry that could get caught in moving parts of the machine.
- Safety boots with non-slip sole, crush-resistant toe cap and protection against cuts (do not wear sandals or work barefoot).
- Sturdy gloves resistant to cuts and vibrations.
- Safety visor or protective goggles. Remove the protective film if any.
- Hearing protection.
- Hard hat (if there is any risk of falling objects).

Health precautions

6 Avoid prolonged use. Noise and vibrations may be dangerous. Prolonged use of the machine or other equipment expose the operator to vibrations that can cause the White Finger Syndrome (*Syndrôme of Raynaud*). This could reduce the sensitivity of the hands in distinguishing different temperatures and cause a general numbness. The operator should therefore check the conditions of the hands and fingers if the machine is used continuously or regularly. If one of the symptoms should appear, consult a doctor immediately. Prolonged use of the machine or other equipment can cause discomfort, stress, fatigue, hearing damage. Wear suitable hearing protection when using the machine. Correct and scrupulous maintenance can also help to protect you further from the risk of noise and vibration.

7 Avoid contact of the eyes and skin with any oil or fuel. Do not inhale the gasoline fumes as they are toxic. Do not start or run the motor in closed or poorly ventilated places. The exhaust fumes are poisonous to breathe and can be asphyxiating and even fatal.

Work zone

8 Examine the work area and be careful of any hazards (such as roads, driveways, power lines, hanging tree limbs, etc.). Take special care when working on sloping terrain. Before use, remove any rubbish from the work area such as rocks, broken glass, ropes, metal parts, cans, bottles and any foreign body that could become entangled with rotating parts or be projected dangerously at a distance. Take account of possible hazards that may not be perceived because of the noise of the machine. Make sure there is someone in the vicinity within safe calling distance in case of accident.

During use

9 During use and for a few minutes after switching off the machine, the gearbox and zone near the shaft on which the cutting device is fastened are very hot. The muffler and its guard are very hot during use and after the engine has been switched off, even with the engine running at minimum speed. Contact can cause burns. Do not touch these parts if they are still hot.

10 Twigs or grass may jam between the safety guard and the blade or nylon string head. Never try to remove this material with the engine running and/or the blade rotating. Watch out for the rotating parts and hot surfaces of the machine. Contact between the blades and any extraneous objects could cause serious injury to the operator or other people or animals in the vicinity, and could also damage the machine. Cut only the material recommended for each accessory and take care not to let the blades come into contact with rocks, metal parts, etc. The blade is sharp, so be very careful when handling it even with the engine off.

11 Keep any other persons or animals away from the work zone (minimum distance 15 meters). Since there is a danger when you are working that the blade or nylon string head could throw out grass, dirt, rocks or foreign bodies, when someone approaches switch the engine off or stop the blade or rotating head (see section entitled "*Starting and stopping the engine*"). Fasten your hair above shoulder length. Start the machine in a flat place, in a stable position, making sure the cutting tool does not touch any obstacles. Use the machine holding it to the right of your body so that the exhaust fumes can escape freely without obstruction from your clothing. While working, grip the brush cutter firmly with both hands. Stand in a stable position on your feet. Keep the grips clean and dry. Do not use the brush cutter while standing on a ladder or other unstable support. You should always be able to control your balance. Never use the machine under extreme weather conditions or in bad weather (very low temperatures, very hot, humid climate, fog, rain, wind, etc.). Keep all parts of your body and clothing away from the blades during startup or when the engine is running. During use, keep the work zone in front of you. Never cut walking backwards as you cannot see possible hazards. Do not put the machine down with the engine running. Never leave the machine alone. Never raise the brush cutter above knee level during cutting.

12 Adjust the shaft fastening buckle so that the blade or line cutter head are parallel to the ground. The connection point should be held in the original position so as to avoid unbalancing the shaft.

Precautions for carrying the machine

13 Never carry the brush cutter, even for short distances, with the engine running. Switch off the engine and carry it with the blade or nylon string head facing backward. For your safety, during transport and storage, always protect the blade with the guard supplied with the machine (see "*Protection for transport*"). When you transport the brush cutter in a motor vehicle, place it in a stable fixed position so that no fuel leaks out. We recommend emptying the fuel tank whenever you transport the machine.

Fire prevention precautions

14 Never work with the brush cutter in the presence of fire or spilled gasoline. If you have spilt it on yourself, change your clothes at once. Keep the machine clean by removing any grass cuttings, leaves, excess oil to reduce the fire hazard. Engine exhaust fumes can get very

hot and may contain sparks. Do not use the machine near inflammable material. The muffler gets very hot during use and remains hot for some time after switching off the engine. This also applies at idle speed. Take every precaution to reduce the fire hazard, especially in the presence of inflammable materials or gas. Start the engine at a distance from the filling site and far away from any fuel tanks (at least 3 meters).

15 When filling the fuel tank, dry any spilled fuel. Never add fuel in the tank when the engine is running or hot to avoid the risk of fire (let the engine cool off before filling the tank). Fill the tank outdoor, far from flames or sparks. Do not take the cap off the tank with the engine running. Open the cap on the tank carefully to eliminate any excess pressure. After fueling, close the cap tightly. Take care not to spill any fuel. The fumes produced by the fuel can cause an explosion or fire. Gasoline is highly inflammable: before going near any type of fuel, put out your cigarette, pipe or cigar. Do not smoke or take sources of heat or sparks near the fuel. Never refuel near or over inflammable objects (dry leaves, etc.).

Kickback

16 Machines equipped with blades may produce a violent kickback on contact with solid bodies. The force of the kickback can cause the operator to lose control of the machine. The blade is capable of amputating arms and legs. Always work with a sharp blade. A blade

with worn teeth can create problems in cutting and can cause KICKBACK, that is, a violent thrust on the front of the machine caused by the impact of the blade against wood or solid foreign bodies. This kickback can cause loss of control of the machine. Never sharpen a damaged blade: replace with a new one. Kickback can also occur when cutting with any type of blade in the hazardous zone (see 13). Do not let the blade cut in the risk sector to prevent kickback.

Precautions for operating a split shaft machine

17 If your machine is a split shaft model, that is to say composed of a power unit (1) and an attachment (2), you must furthermore conform to the following rules: Never turn on the machine without an attachment correctly fitted. Before every start check the attachment/shaft joint and the attachment to be assembled correctly and in excellent conditions.

This manual is meant to be: the manual of the power unit; the manual of the string head/grass blade attachment and, moreover, if not explicitly stated otherwise, it refers to the two units as already assembled in their proper way (see chapter E6. attachments fitting/removal).

When using other attachments, carefully read their instruction manual and make sure you understand them before using. This machine allows the fitting of the following attachments only: UNIVERSAL OUTDOOR ACCESSORIES - Hedge Cutter Attachment.

C. Description of the safety devices on the machine



1 2 3 4

Safety lever



Never use the machine with its Safety lever pressed with adhesive tape, string or other.

This device serves to prevent accidentally pressing the throttle trigger (fig. A no. 3). In fact, the trigger (fig. A no. 3), can only be pressed if the safety lever is pressed at the same time (fig. A no. 19). By means of 2 separate springs, upon releasing the grip, the throttle trigger (fig. A no. 3) and safety lever (fig. A no. 19) return automatically to their original positions.

Engine stop device

Turn the stop button Stop (fig. A no. 7) to O / STOP to stop the engine. To make sure this button works properly, start the engine and check that it stops when the Stop button is turned to the Stop position.

Protection for transport



4 10 13



Never use a machine with the blade cover still on.

The guard covers the sharp extremities of the

blade when the machine is in the resting position for transport or storage.

Safety guard



1 2 3 4 10

This very important safety device (fig. A no.19) prevents any objects that come into contact with the cutting device, or the grass itself, from flying up and striking the operator.

Safety pole guard



1 2 3 4

This device, fastened to the machine, ensures a minimum distance between the operator and the cutting device during use, and prevents the machine from striking and injuring the operator if the blade hits a hard surface (fig. A no. 20).

Muffler



1 2 3 4 6 7 9 14

The muffler serves to reduce the noise level to a minimum and to route the exhaust fumes produced by the combustion engine away from the operator.

Harness

 **CAUTION! It is very important to familiarize yourself with the release mechanism. In case of emergency you need to be able to release the machine quickly.**

The harness is equipped with a fasten-release mechanism. The harness enables the operator to support the machine during use (see "Safety precautions", B7).

D. Fuel Mixture

Preparation of the mixture



 Do not use any other type of fuel than the type recommended in this manual. This machine is equipped with a two-stroke engine and should therefore be fueled with a mixture of unleaded gasoline (with a minimum octane rating = 90) and fully synthetic oil specific for two-speed engines that use unleaded gasoline in the proportions indicated in the table on the cover, fig. D.

 Control the specifications of the oil shown on the package; the use of oil lacking the specifications expressly indicated in this manual could cause serious damage to the engine!

To obtain the best mixture, pour the oil into an approved container first, followed by the gasoline, and shake the container well (every time you take fuel out of it).

The characteristics of the mixture tend to deteriorate in time, so you should only prepare as much mixture as you are going to need (the use of deteriorated fuel can seriously damage the engine).

Filling the tank



Clean the area around the fuel cap before removing it, to prevent any impurities from contaminating the fuel. Take the cap off the fuel container carefully. Unscrew the cap on the fuel tank and fill it with the necessary quantity, using a funnel. During use, to prevent problems in starting the engine again, we strongly recommend that you avoid letting the fuel run out in the tank.

Fuel storage



 Store the fuel in a cool, well-ventilated place, in an approved fuel storage container.

Never store the engine with fuel in the tank in a poorly ventilated place where the fumes produced by the gasoline could propagate and reach a fire, candle, burner or furnace pilot light, water heater, dryer, etc. Never store excessive quantities of fuel.

E. Assembly/disassembly

E1. Delta grip



For your safety, fasten the delta handle in front of the label placed on the shaft at a distance of at least 18 cm from the rear grip. The handle should be fastened in a comfortable working position. The safety pole guard should be mounted using the accessories supplied and in the configuration shown in the figure, in contact with the delta handle.

E2. Double Handle

Adjust and secure double hand clamp by tightening the screws.

E3. Assembly of safety guard

Fit the safety guard (A) against the gearbox (I) position the lower clamp (G) in the housing under the shield and the upper clamp (F) over the shaft. Insert and tighten the screws (H).

Safety guard extension (exclusively for use with nylon string head)

- The extension (B) should be installed only for use with the nylon string head, with the aid of the string cutter blade (L), that regulates the length of the string and thus the cutting diameter.
- For correct assembly see the illustration on the cover and perform the following sequence of steps:
- Insert the extension (B) on the safety guard (A) at the reference notches (C), and fasten with the screws (D), then apply the string cutter blade (L) with the cutting edge facing towards the outside of the shield, and fasten it with the screw (E) (Make sure the screws are tightened all the way (E) and are not loosened by the vibrations. If necessary, tighten them again).

 **CAUTION!** If you are using the grass cutting blade, remove the extension (B) on the guard (A).

E4. Assembly/disassembly of line cutter head



Apply the nylon string head as shown in the illustration: 1) Upper plate 2) Protection (not supplied with all models) 3) Nylon string head. Tighten by turning counterclockwise. As you tighten, hold the nylon string head and plate still and insert the wrench or screwdriver supplied in the holes in the plate and gearbox; first turn the plate until the two holes match.

E5. Assembly/disassembly of grass cutter blade



Apply the blade as shown in the illustration: a) Upper plate with blade centering b) Protection (not supplied with all models) c) Blade with word and direction arrow facing upward d) Lower plate e) Fixed cup f) Blade fastening nut.



CAUTION! Do not use the nylon string head guard extension with metal blades.

E6. Attachments fitting/removal (for split shaft models only)

- 1) Loosen the joint knob first, then insert attachment's shaft into the shaft/attachment joint and make sure that the locking pin (A) is secured in one of its housings, finally lock firmly the joint knob (B).
- 2) To remove the attachment from the power unit: loosen the joint knob(1), push the locking pin (2) and, keeping it pressed, remove attachment's shaft from the joint(3).
- 3) Every attachment manual explains through a picture in which ways each attachment can be assembled on the power unit: a configuration is forbidden if crossed, if marked with "NO" and/or the symbol **X**, or if it isn't shown at all. A configuration is allowed if marked with "OK" and/or the symbol **✓**.

The figure shows assembling configurations allowed for the string head/grass blade attachment (with the rules defined in the previous paragraph, it is forbidden to assemble the string head/grass blade attachment with the locking pin in both left and right housings, allowing its assembling in the upper housing only).

F. Starting and stopping the engine



CAUTION!

Start the brush cutter in a flat place. During startup stand in a stable position. Make sure the blade or nylon string head do not touch the ground or any obstacles.



CAUTION!

Grip the knob of the starter with one hand and hold the machine in a stable position with the other. (Take care not to wind the starter string around your hand) and pull slowly until you encounter some resistance, then pull the cord sharply and forcefully (to start the engine when Do not pull the starter cord all the way and do not release it abruptly against the machine as this could damage it.

COLD ENGINE STARTING

- 1) Move stop switch to the "ON" position.
- 2) Depress the safety lever (S), squeeze the accelerator trigger (A) and push the throttle advance forwards (B). Now release the accelerator trigger (A) and then the throttle advance (B).
WARNING: when the throttle advance is engaged, the head or blade rotates.
- 3) Move choke lever (E) to the closed position |•|.
- 4) Press the primer bulb (C) several times until

you see fuel going back to carburetor through pipe (D). Pull starter rope until engine fires once.

- 5) Move choke lever (E) to the open position |•| then pull starter rope until engine fires. Let engine run for a few seconds holding the trimmer. Now disengage throttle advance by pulling trigger completely. Engine will now keep on running at idle speed.

HOT ENGINE STARTING

STOP switch on START position I. Trigger on idle position (released). Choke towards (open position |•|).

Press the primer bulb (C) several times until you see fuel going back to carburetor through pipe (D). Pull starter rope.

WARNING: when the throttle (B) advance is engaged, the head or blade rotates.

6) ENGINE STOPPING

Press the stop switch moving it to STOP position 0.

WARNING: when the engine is switched off rotating parts, blade or nylon string head, will keep on rotating for a few seconds. Hold the machine until all parts come to a standstill.

N.B. In an emergency the above mentioned delay in stopping may be shortened by touching blade parallel on the ground.

G. Carburetor adjustment



8 9 10 11

Your machine can be equipped with a low emission carburetor. We recommend that you have any adjustment of the carburetor made exclusively by an authorized service center, which disposes of special equipment for ensuring the best performance with the lowest emissions. To adjust the speed to the minimum, turn the screw marked (T) as shown: With the engine running and well warmed up, turn the screw (T) gently clockwise, until the engine rotates at regular speed (stead noise), without the cutting devices in motion. If

the cutting devices are moving, turn the screw (T) gently counterclockwise until you obtain the proper adjustment. The correct minimum speed is shown in the instruction manual in the paragraph of technical data.



All the above adjustments should be made with the cutting devices correctly installed.

The warranty may be invalidated due to erroneous adjustments made by personnel not belonging to authorized service centers.

H. Routine maintenance



1 2 3 4 7 9 10 17

H1. After every use

In order to avoid overheating the motor, remove any dust and dirt from the slots on the cylinder cover and fins of the cylinder using a wooden scraper. Store the machine in a dry place.

After 25 hours of use

Remove the filter as shown in the figure and clean it using a gentle jet of compressed air. For more thorough cleansing, you can wash it with soapy water.

After 50 hours of use

Add some high speed gear grease in the gearbox through hole (C). Remove and clean the spark plug (set the space between the electrode at 0.5/0.6 mm). Replace if excessively encrusted. In case of excessive encrustation check the carburetor adjustment, the percentage of oil in the fuel mixture and make sure the oil is of excellent quality and suitable for two-stroke engines.

After 100 hours of use

Replace the spark plug.

Every three months

Contact your Service Center for a complete overhaul, replacement of the fuel filter and cleaning of the parts inside the machine. This will reduce the possibility of unexpected problems and will

ensure the good performance and long life of your machine.

Periods of prolonged disuse

See "Environmental information".



If you use the machine in an exceptionally dirty or dusty environment these operations should be carried out more often.

H2. Replacement of nylon string

To replace the reel of string, press both the release pawls indicated by the arrows, remove the empty reel, unroll any string left and rewind the new string. Open the original package of string and insert the ends of the two strings in the eyelets on the reel, then wind the strings completely on the reel in the same direction and fasten the end of each string in the 2 opposite grooves. Replace the reel in its housing and thread the ends of the strings in their bushings. Pull each string so that about 15 cm comes out on each side. Reassemble the nylon string head as shown. If the reel becomes excessively worn, replace it with a whole new reel.

H3. Attachments maintenance

Follow maintenance instructions on the attachment manual.

I. Techniques for use



1 4 5 6 7 8 9

10 11 12 13 14 16 17

Cutting techniques



During the cutting operations, keep the engine running at high speed. After every cutting stage, decelerate the engine to minimum

speed as running it at top speed without a load can damage the engine severely.



Wait until the engine is running at minimum speed before moving the machine from one section to another.

The machine is ideal to complete the work of the lawnmower. In fact, it can reach places where a

normal lawnmower is unable to go.

Cutting and trimming grass borders with the nylon string head

Cutting with the nylon string head is suitable for light jobs like trimming borders and cutting the grass around trees.

Mowing

To prevent damage to your lawn or the cutting mechanism, keep the string parallel to the ground but avoid contact with the terrain.

Trimming borders

Angle the nylon string head keeping it a short distance from the ground. Cut using the end of the string. Do not press the string against the material to be cut.

I1. Drawing out the string

During cutting, the nylon string wears naturally causing an increase in the speed of the engine and a reduced cutting capacity. When this happens, to bring out more string bump the head

against the ground: release the throttle trigger to reduce the engine speed to less than 8000 rpm. Tap gently on the ground with the button (A) as shown in the figure and the string will come out automatically. Accelerate again. If the string does not come out make sure there is still some left and try again.

I2. Thinning grass with the grass cutter blade



The grass is cut with swinging motions from side to side, maintaining the blade parallel to the ground. During the right to left swing the grass is cut, while the backswing must be made without using the blade.

KICKBACK can occur when cutting is done with the risk sector of the blade; we recommend cutting with the rest of the blade. Take care that the cup supporting the blade just grazes the ground. This will prevent the blade from touching the ground.

L. Environmental information

This section contains information useful for maintaining the characteristics of eco-compatibility included in the origin design of the machine, and as regards proper use and disposal of oil and fuel.

Design

In the design stage, care was taken to develop an engine with reduced consumption and low emissions of noise and pollutant exhaust fumes.

Use of machine

The operations of filling the tank with the fuel mix-

ture should be carried out in such a way as to avoid spilling fuel and contaminating the soil and environment.

Periods of prolonged disuse

Always empty the fuel tank with the same precautions used in filling it.

Disposal

Do not dispose inappropriately of the machine when it is no longer usable. Deliver it to an authorized organization for proper disposal in compliance with the regulations in force.

M. Troubleshooting table

	Engine will not start	Engine runs badly or loses power when cutting	The machine runs but does not cut well
Check STOP switch is in the position I.	●		
Control fuel level min. 25% tank capacity.	●	●	
Check air filter is clean.	●	●	
Remove spark plug, dry it, clean it and adjust it, and replace it, if necessary.	●	●	
Change fuel filter. Contact your dealer.		●	
Carefully follow the cutting accessory assembly instructions.			●
Check metal cutting accessory is sharp. Otherwise, contact your dealer.			●

The engine continues to have problems: contact your authorized supplier

N. Declaration of conformity

The undersigned, authorized by Husqvarna Outdoor Products Italy S.p.A., declares that the following products model /TYPE: **BC050, BC060** starting from the serial numbers produced from 2006 on, manufactured by Husqvarna Outdoor Products Italy S.p.A., Valmadrera, Italia, comply with European Directive: 98/37/EEC (Machine Directive), 93/68/EEC (EEC Marking Directive) & 89/336/EEC (Electromagnetic Compatibility Directive), directive 2000/14/EEC (Enclosure V).



Valmadrera, 15.10.06
Giuseppe Todero (Technical Manager)
Husqvarna Outdoor Products Italy S.p.A.
Via Como 72, 23868 Valmadrera (Lecco) ITALY

O. Technical data

Displacement (cm ³)	34	40
Bore (mm)	38	40
Stroke (mm)	30	32
Engine output (kW) (ISO 8893)	1,2	1,5
Maximum shaft rotation frequency (min ⁻¹)	7.700	7.700
Rotation speed (frequency of rotation) of engine at maximum rotation frequency recommended for shaft (min ⁻¹)	12.100	12.100
Engine speed at max power (min ⁻¹)	8.000	8.000
Minimum speed (min ⁻¹)	2.800	2.800
Maximum speed, no load (min ⁻¹)	10.000	10.000
Dry weight (kg)	7,1	7,3
Fuel tank capacity (cm ³)	1000	1000
Blade locking nut tightening torque (Nm)	17	17
Noise pressure (at operator ear) L _{pav} (dBA) (ISO 7917)	97	97
Measured sound power level L _{wav} (dBA) (ISO 10884)	113	113
Guaranteed noise level L _{wav} (dBA) (ISO 10884)	114	114
Vibrations level string head (ISO 7916) (m/s ²) max-min	8,2-1,6	8,2-1,7
Vibrations level blade (ISO 7916) (m/s ²) max-min	8,2-1,6	8,2-1,7