

OLYMPUS®

Modules described in this manual

SZ2-ST
WHSZ Series Eyepieces
Objectives
SZX-EPA
SZX-AS
SZX-STAD1
SZH-STAD1
SZ2-FO
SZH-SG
SZH-SC

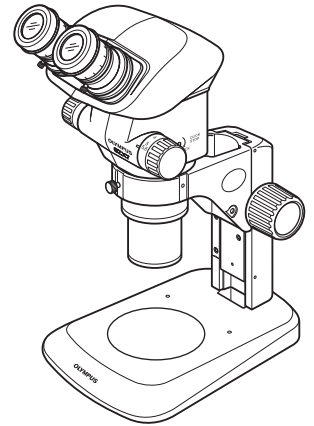

INSTRUCTIONS

SZX7

STEREOMICROSCOPE SYSTEM

This instruction manual is for the Olympus stereomicroscope system. To ensure the safety, obtain optimum performance and to familiarize yourself fully with the use of this microscope, we recommend that you study this manual thoroughly before operating the microscope. Retain this instruction manual in an easily accessible place near the work desk for future reference.



A X 6 6 3 1

CONTENTS

Correct assembly and adjustments are critical for the microscope to manifest its full performance. If you are going to assemble the microscope by yourself, please read Chapter 8, "ASSEMBLY" (pages 16 to 18). For the assemblies of the modules for which instruction manuals are available, refer to their instruction manuals.

IMPORTANT – Be sure to read this chapter for safe use of the equipment. – 1-2

1	NOMENCLATURE	3
2	CONTROLS	4
3	OBSERVATION PROCEDURE	5
4	OPERATION	6-12
4-1	Stand	6
	1 Using the Stage	
	2 Adjusting the Focus Adjustment Knob Tension	
4-2	Observation Tube	6-9
	1 Adjusting the Interpupillary Distance	
	2 Adjusting the Diopter (Zoom Confocality Adjustment)	
	3 Using the Eye Shades	
	4 Using an Eyepiece Micrometer Disk	
	5 Selecting the Light Path (SZX-TR30)	
	6 Adjusting the Tilt (SZX-TBI)	
4-3	Microscope Body	10-11
	1 Zoom Magnification Indication	
	2 Switching the Click Stop ON-OFF	
	3 Using Auxiliary Sleeve SZ2-ET	
4-4	TV Observation and Photomicrography	12
5	TROUBLESHOOTING GUIDE	13
6	SPECIFICATIONS	14
7	OPTICAL PERFORMANCE	15
8	ASSEMBLY	16-18
9	OPTIONAL MODULES	19-27

SZX-EPA, SZX-AS, SZX-STAD1, SZH-STAD1, SZ2-FO, SZH-SG, SZH-SC

IMPORTANT

The SZX7 stereomicroscope is provided with the ESD (Electro-Static Discharge) protection specifications. It is provided with electroconductive coating in the external finish to reduce the surface resistance and grounding lead wires in their standard stand or system to eliminate static electricity from them.

CAUTION To maintain the ESD protection performance, always use the microscope in combination with the modules described in this manual or options having the ESD protection specifications. Otherwise, the grounding will not work properly.

SAFETY PRECAUTIONS

1. After the equipment has been used in an observation of a specimen that is accompanied with a potential of infection, clean the parts coming in contact with the specimen to prevent infection.

- Moving this microscope is accompanied with the risk of dropping the specimen. Be sure to remove the specimen before moving this product.
- Hold the bottom of the stand with one hand while holding base column with the other hand to avoid tilting the microscope.
- In case the specimen is damaged by erroneous operation, promptly take the infection prevention measures.

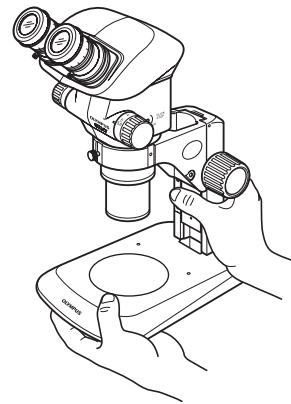

2. The desktop should be a level surface with an inclination of less than 3°, and the load to the microscope should be less than 7 kg (when the SZ2-ST standard stand is used).

The microscope may become unstable when certain intermediate attachment and/or photography unit are mounted on it. Be careful so that the microscope does not topple down.

3. When the microscope is to be disposed of, follow your local industrial waste disposal regulations. If you have any questions, please contact Olympus.

1 Getting Ready

1. A microscope is a precision instrument. Handle it with care and avoid subjecting it to sudden or severe impact.
2. Do not use the microscope where it is subjected to direct sunlight, high temperature and humidity, dust or vibrations. (For the operating conditions, see Chapter 6, "SPECIFICATIONS" on page 14.)
3. Do not turn the zoom adjustment knobs beyond the stopper positions. Otherwise, the internal mechanism may be damaged.

Do not turn the left and right zoom adjustment knobs in the opposite directions, as this will result in a failure.

4. Only one intermediate attachment having thickness up to 60 mm can be mounted on the microscope. If two intermediate attachments or an intermediate attachment thicker than 60 mm is mounted, the image may be cut a little.

However, the coaxial reflected light illuminator (SZX-ILLC) is not counted in the number of intermediate attachment.

©When using multiple modules, they should be stacked in order of the SZX-ILLC, SZX-AS, SZX-RFA (SZX-RFL), SZX-SDO, SZX-APT, SZX-BS, SZX-DA, SZX-FAD and SZX-EPA from the bottom to the top.

2 Maintenance and Storage

1. To clean the lenses and other glass components, simply blow dirty away using a commercially available blower and wipe gently using a piece of cleaning paper (or clean gauze).
If a lens is stained with fingerprints or oil smudges, wipe it gauze slightly moistened with commercially available absolute alcohol.
▲ Since the absolute alcohol is highly flammable, it must be handled carefully.
Be sure to keep it away from open flames or potential sources of electrical sparks — for example, electrical equipment that is being switched on or off.
Also remember to always use it only in a well-ventilated room.
2. Do not attempt to use organic solvents to clean the microscope components other than the glass components because they use plastic resin materials extensively. To clean them, use a lint-free, soft cloth slightly moistened with a diluted neutral detergent.
3. Do not disassemble any part of the microscope as this could result in malfunction or reduced performance.
4. When disposing of the microscope. Check the regulations and rules of your local government and be sure to observe them.

3 Caution

If the microscope is used in a manner not specified by this manual, the safety of the user may be imperiled. In addition, the equipment may also be damaged. Always use the equipment as outlined in this instruction manual.

The following symbols are used to set off text in this instruction manual.

- ▲ : Indicates that failure to follow the instructions in the warning could result in bodily harm to the user and/or damage to equipment (including objects in the vicinity of the equipment).
- ★ : Indicates that failure to follow the instructions could result in damage to equipment.
- ◎ : Indicates commentary (for ease of operation and maintenance).

4 Intended use

This instrument has been designed to be used to observe magnified images of specimens in routine and research applications.

Do not use this instrument for any purpose other than its intended use.



This device complies with the requirements of directive 98/79/EC concerning in vitro diagnostic medical devices. CE marking means the conformity to the directive.

NOTE: This equipment has been tested and found to comply with the limits for a Class A digital device, pursuant to Part 15 of the FCC Rules. These limits are designed to provide reasonable protection against harmful interference when the equipment is operated in a commercial environment. This equipment generates, uses, and can radiate radio frequency energy and, if not installed and used in accordance with the instruction manual, may cause harmful interference to radio communications. Operation of this equipment in a residential area is likely to cause harmful interference in which case the user will be required to correct the interference at his own expense.

FCC WARNING: Changes or modifications not expressly approved by the party responsible for compliance could void the user's authority to operate the equipment.

1 NOMENCLATURE

* Modules marked * are given the ESD specifications.

(Note) The modules shown in the following diagram are merely the typical examples. For the modules that are not shown below, please consult Olympus or the latest catalogues.

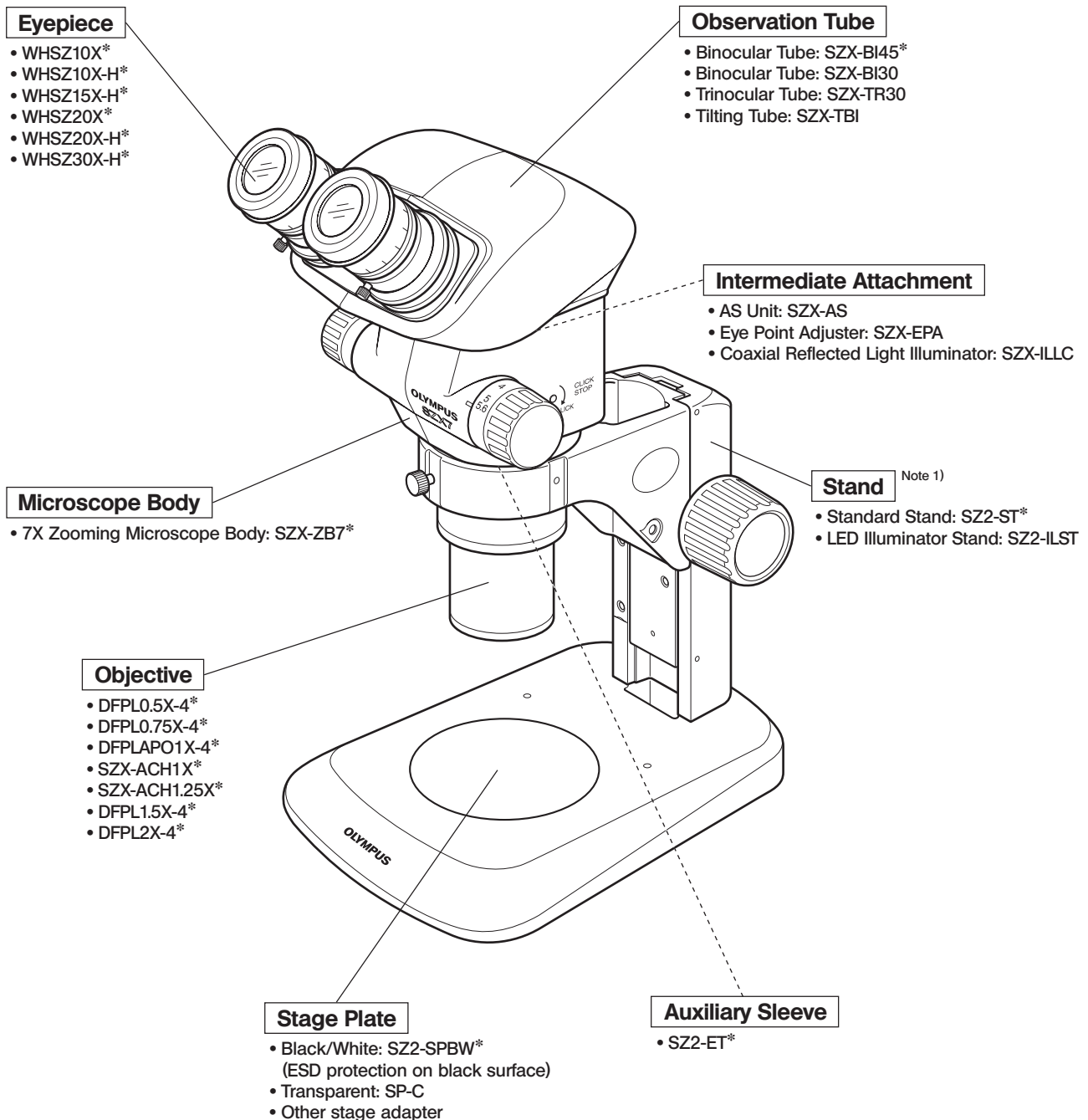

Note 1) The microscope can also be mounted on the SZ2-STU1/STU2/STU3 large stand as well as on the SZX-ST SZX standard stand by using the SZ2-STB1/SZ2-STS focusing arm.

2 CONTROLS

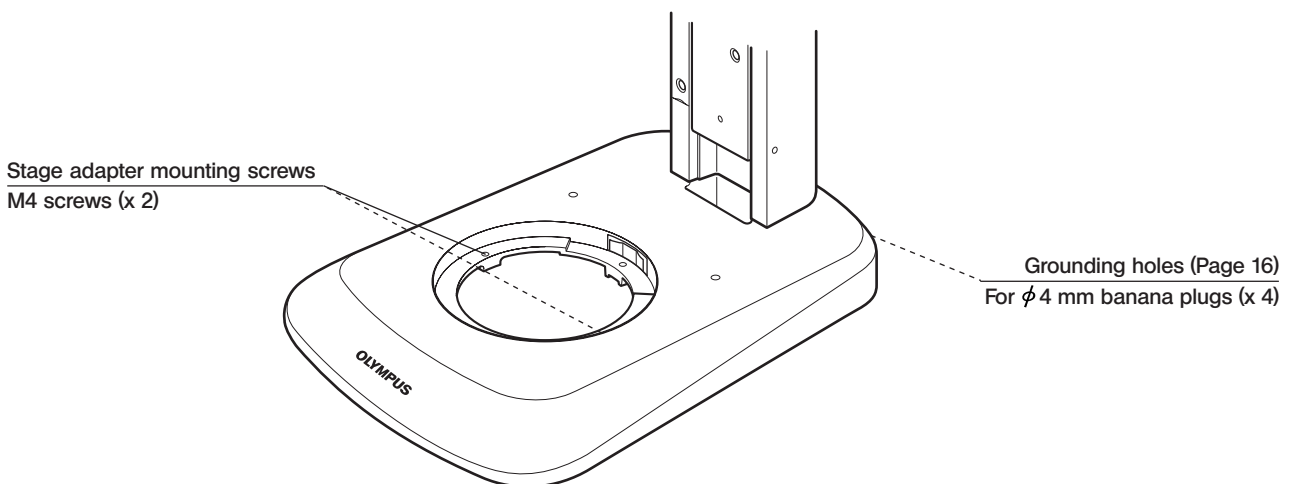
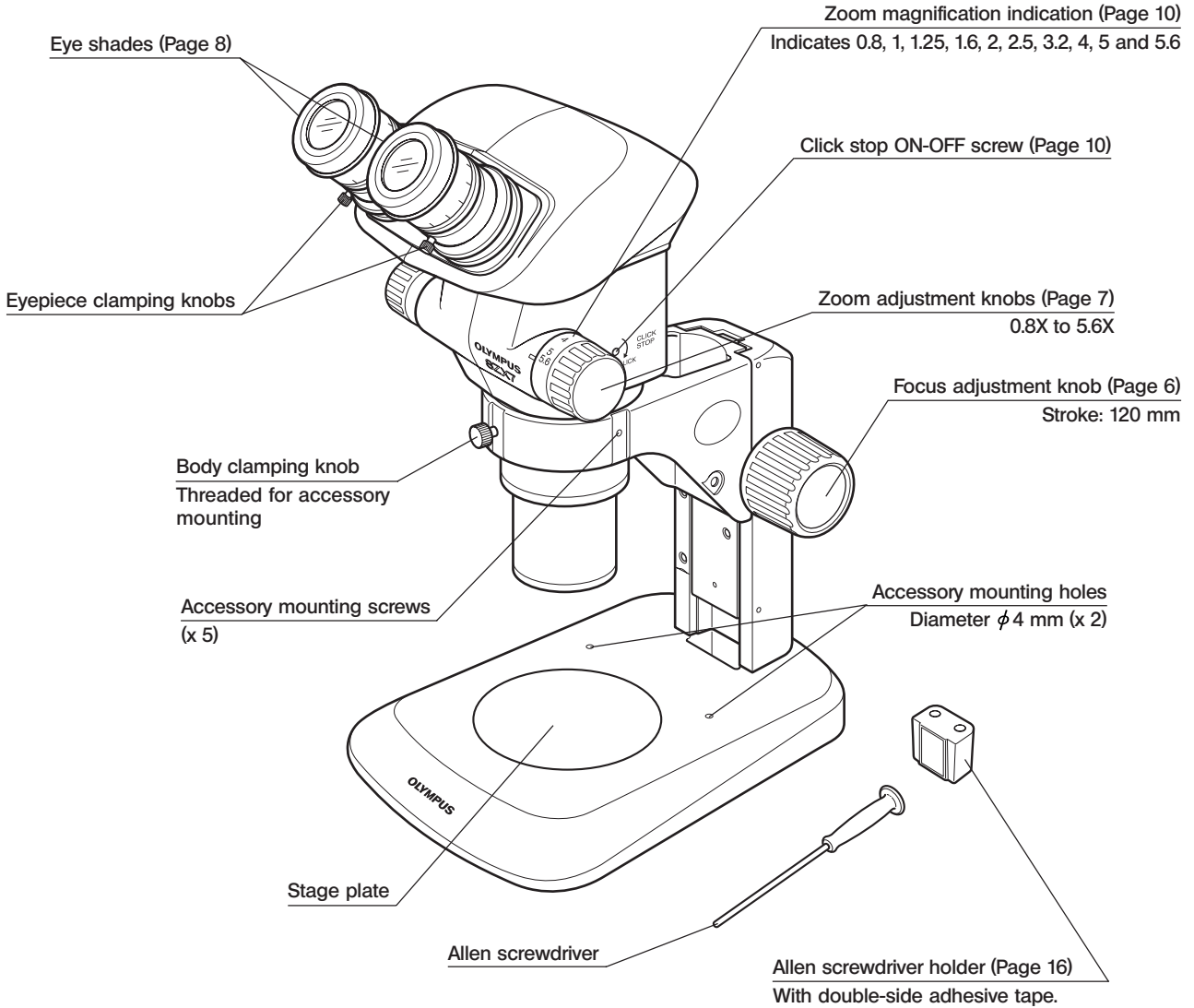

3 OBSERVATION PROCEDURE

©If you have not assembled the microscope yet, please read Chapter 8, "ASSEMBLY" (pages 16 to 18).

3-1 Preparation

- (Page)
1. Confirm the mounting, particularly that of the observation tube. (P. 16 - 18)
 2. Adjust the rotation tension of the focus adjustment knob. (P. 6)
 3. Prepare the light source as required.

3-2 Procedure

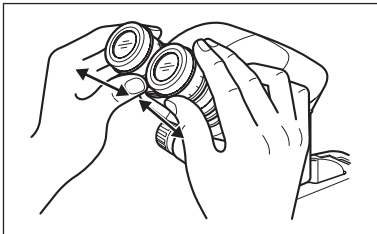

1. Place the specimen on the stage. (Page 6)
2. Adjust the interpupillary distance. (Page 6)
3. Adjust the eyepiece diopter. (Page 7)
 - The adjustment operation is variable whether the eyepieces use an eyepiece micrometer disk or not.

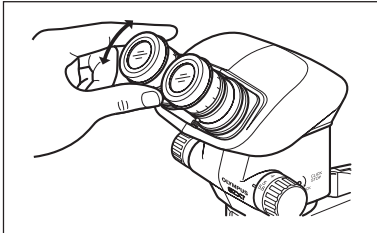

4. Set the zoom adjustment knob ① for the lowest magnification and rotate the focus adjustment knob ② to bring the specimen into approximate focus.
5. Rotate the zoom adjustment knob ① to the target magnification and rotate the focus adjustment knob ② to bring the specimen into accurate focus.

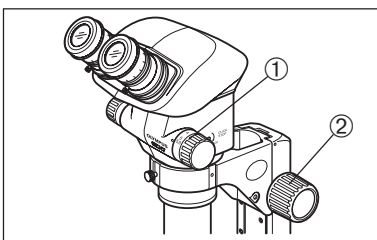

©When the optional AS unit (SZX-AS) is used, the contrast of image and the focal depth of specimen can be adjusted with the aperture iris diaphragm lever.

4 OPERATION

4-1 Stand

1 Using the Stage

1. When reflected light illumination is used, the stage plate can be placed either the white or black surface facing up depending on the specimen. However, when the ESD performance is required, always use the black surface of the stage plate.
2. When transmitted light illumination is used, use the transparent glass stage plate (SP-C).

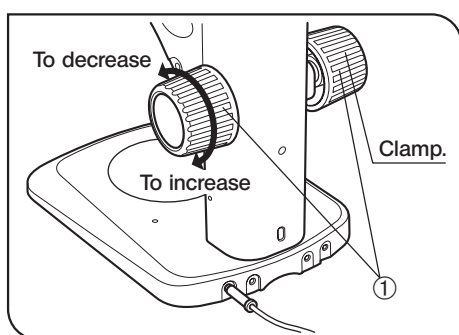

Fig. 1

2 Adjusting the Focus Adjustment Knob Tension (Fig. 1)

⊙ This operation is intended to facilitate the rotation of the knobs while preventing spontaneous drop of the microscope body. It is recommended to set the knob tension to a slightly higher level than the point where spontaneous drop occurs.

1. Hold the left and right focus adjustment knobs ① with both hands, fix the left knob and rotate the right knob. The rotation tension of the knobs increases or decreases according to the direction in which the right knob is rotated.
2. If the rotation tension is increased too much, accurate focusing is not possible and the mechanism may be damaged.

4-2 Observation Tube

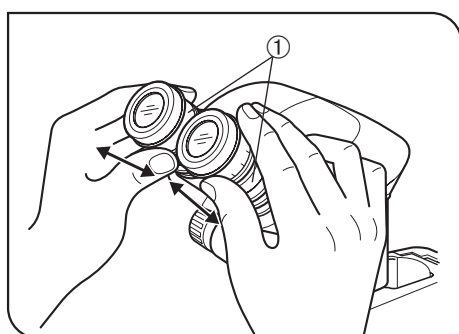

Fig. 2

1 Adjusting the Interpupillary Distance (Fig. 2)

★ Always hold the eyepiece sleeves ① with both hands when adjusting the interpupillary distance.

While holding the left and right eyepiece sleeves ① with both hands, look through the eyepieces and adjust for binocular vision until the left and right fields of view coincide completely.

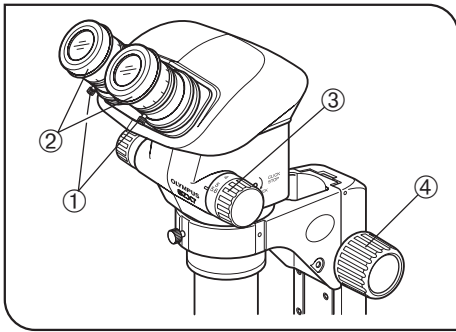

Fig. 3

2 Adjusting the Diopter (Zoom Confocality Adjustment) (Fig. 3)

★ Confirm that the eyepiece clamping knobs ① are tightened firmly before proceeding to the adjustment.

Eyepieces without eyepiece micrometer disk

1. Turn the diopter adjustment rings ② of the left and right eyepieces to positions "0". (This adjustment is not possible with eyepieces without helicoids)
 2. Place an easy-to-observe specimen on the stage plate.
 3. Set the zoom adjustment knob ③ for the lowest magnification and rotate the focus adjustment knob ④ to bring the specimen into focus.
 4. Set the zoom adjustment knob ③ for the highest magnification and rotate the focus adjustment knob ④ to bring the specimen into focus.
 5. Set the zoom adjustment knob ③ for the lowest magnification and rotate the diopter adjustment rings ② of the left and right eyepieces, instead of the focus adjustment knob, to bring the specimen into focus.
- ☉ Set the zoom adjustment knob ③ for the highest magnification again and check the image focusing. The diopter adjustment is complete if the image is in accurate focus. If not, repeat steps 3 to 5 above.

Eyepieces with eyepiece micrometer disk

1. Look through the eyepiece with eyepiece micrometer disk and rotate its diopter adjustment ring ② to bring the micrometer scale into focus.
 2. Place an easy-to-observe specimen on the stage plate.
 3. Set the zoom adjustment knob ③ for low magnification, look through the eyepiece with eyepiece micrometer disk and rotate the focus adjustment knob ④ to bring the specimen into focus.
 4. Set the zoom adjustment knob ③ for the highest magnification, look through the eyepiece with micrometer disk and rotate the focus adjustment knob ④ to bring the specimen into focus.
 5. Set the zoom adjustment knob ③ for the lowest magnification and rotate the diopter adjustment ring of the eyepiece without eyepiece micrometer disk, instead of the focus adjustment knob, to bring the specimen into focus.
- ☉ Set the zoom adjustment knob ③ for the highest magnification again and check the image focusing. The diopter adjustment is complete if the image is in accurate focus. If not, repeat steps 3 to 5 above.
- ☉ Note the left and right diopter scale values so that it can be quickly duplicated in future observations.

Diopter scale of the 10X eyepieces

- ☉ The valid range of the diopter scale is between -8 and +5 but a slight margin is added to it. Therefore, the diopter value may exceed +5 or -8 when it is adjusted to the maximum. In this case, whether the diopter value is over +8 or under -5 can be identified by the length of the eyepiece.

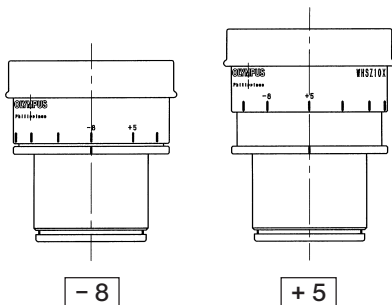

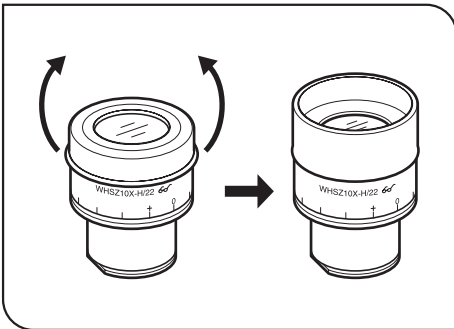

Fig. 4

3 Using the Eye Shades (Fig. 4)

★ The eye shades are not provided with ESD protection performance. When ESD protection is required, do not use the eye shades.

When Wearing Eyeglasses

Use with the eye shades in the normal, folded-down position. This will prevent the eyeglasses from being scratched.

When Not Wearing Eyeglasses

Extend the folded eye shades in the direction of the arrow to prevent extraneous light from entering between the eyepieces and eyes.

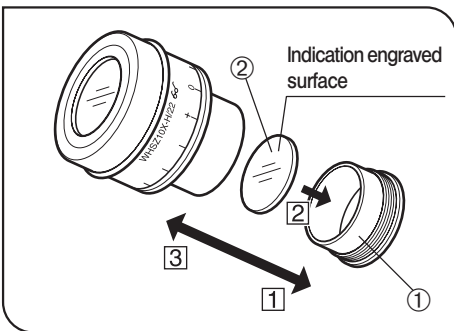

Fig. 5

4 Using an Eyepiece Micrometer Disk (Fig. 5)

WHSZ10X-H/15X-H/20X-H (Fig. 5)

1. Rotate the disk-mounting ring ① of the eyepiece counterclockwise to remove.
2. Prepare an eyepiece micrometer disk ② (24 mm dia. x 1.5 mm thick), remove dust and dirt from its surface, and fit it into the disk-mounting ring ① so that the engraving on the micrometer disk faces downward.
3. Gently screw in the disk-mounting ring ① incorporating the eyepiece micrometer disk into the eyepiece. Turn the ring clockwise to attach it firmly.

WHSZ30X-H (Fig. 6)

1. Rotate the disk-mounting ring ③ of the eyepiece counterclockwise to remove.
2. Rotate the push ring ④ of the eyepiece micrometer disk counterclockwise to remove.
3. Prepare an eyepiece micrometer disk ⑤ (24 mm dia. x 1.5 mm thick), remove dust and dirt from its surface, place it on the disk-mounting ring ③ with the engraving facing downward, and fix it with the push ring ④.
4. Gently screw in the disk-mounting ring ③ incorporating the eyepiece micrometer disk into the eyepiece. Turn the ring clockwise to attach it firmly.

★ Due to their structures the WHSZ20X-H/30X-H eyepieces apply a magnification on the focused plane of the eyepiece micrometer disk. These magnifications are 1.3X with the WHSZ20X-H and 2X with the WHSZ30X-H. Be sure to compensate for these magnifications when using the eyepiece micrometer disk in measurements.

Also, insertion of the eyepiece micrometer disk extends the light path length and deviates the position of the diopter scale. Correct this deviation by turning the diopter adjustment ring of the eyepiece toward “+”.

©When the eyepiece micrometer disk is not used, store it by wrapping in a clean, soft cloth.

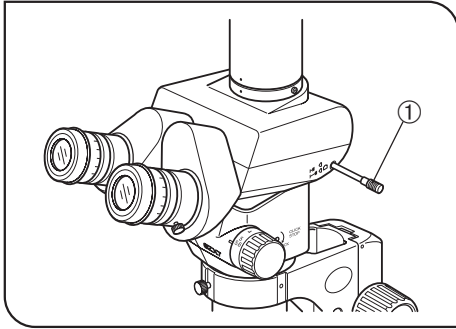



Fig. 7

5 Selecting the Light Path (SZX-TR30) (Fig. 7)

Slide the light path selector knob ① to select the desired light path.

Light Path Selector Knob	Indication	Light Path Ratio
Pushed-in position		Binocular 100%
Pulled-out position		Binocular 20% TV & Photo 80%

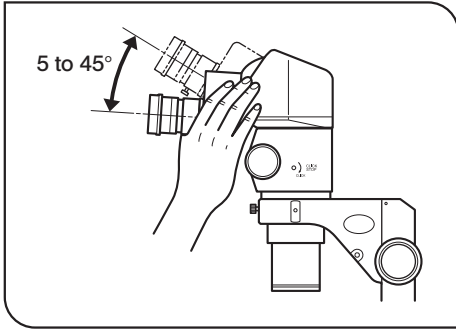

Fig. 8

6 Adjusting the Tilt (SZX-TBI) (Fig. 8)

Ⓒ Adjust the height and tilt of the observation tube to obtain the most comfortable viewing position.

Holding the binocular section with both hands, raise or lower it to the desired position.

★ **Never attempt to force the binocular section past the upper or lower stop position. Applying excessive force could destroy the limiting mechanism.**

4-3 Microscope Body

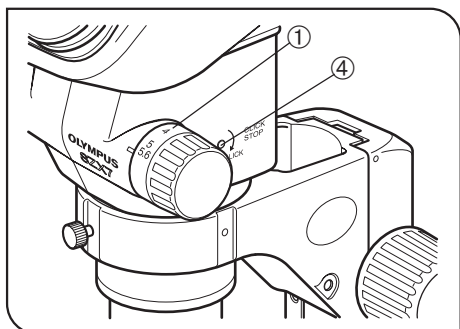

Fig. 9

1 Zoom Magnification Indication (Figs. 9 & 10)

The body zoom magnification is indicated on zoom adjustment knob (right) ①.

The total magnification can be calculated with the following formula.

$$\text{Total magnification} = \text{Objective magnification} \times \text{Body zoom magnification} \times \text{Eyepiece magnification}$$

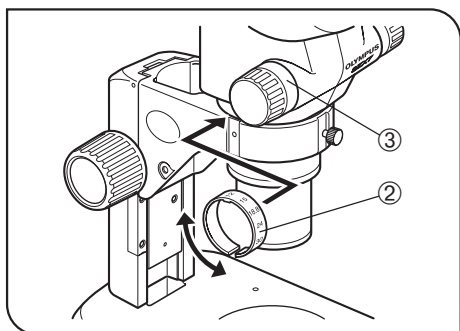

Fig. 10

Total magnification indication ring (Fig. 10)

Ⓞ An objective other than the 1X model is provided with two total magnification indication rings*. Use the ring having indication "SZX7" with the SZX7 microscope.

*: The indicated figures are the total magnification when the 10X eyepiece is used.

1. Widen the magnification indication ring ② and fit into the deep part of the left zoom adjustment knob ③ so that the indicated figures can be read from the front of the microscope.
2. Gently turn the magnification indication until it clicks into the predetermined position.

★ The magnification indication ring can also be attached on the right zoom adjustment knob, but the microscope zoom magnification indication is hidden in this case.

2 Switching the Click Stop ON-OFF (Fig. 9)

Ⓞ The click stop function provides a click stop for each zoom magnification value indicated on the zoom adjustment knob. When the click stop function is switched OFF, the zoom magnification can be adjusted finely around each zoom magnification value.

1. To switch the click stop function ON, turn the click stop screw ④ clockwise (in the direction of the arrow) all the way until it is stopped using the Allen screwdriver.

A click stop is provided for each zoom magnification value indicated on the zoom magnification indication ①.

2. To switch the click stop function OFF, turn the click stop screw ④ counterclockwise (in the opposite direction to the arrow) by about 2 turns using the Allen screwdriver.

★ To prevent damaging the microscope cover and internal mechanism, do not turn the screw excessively.

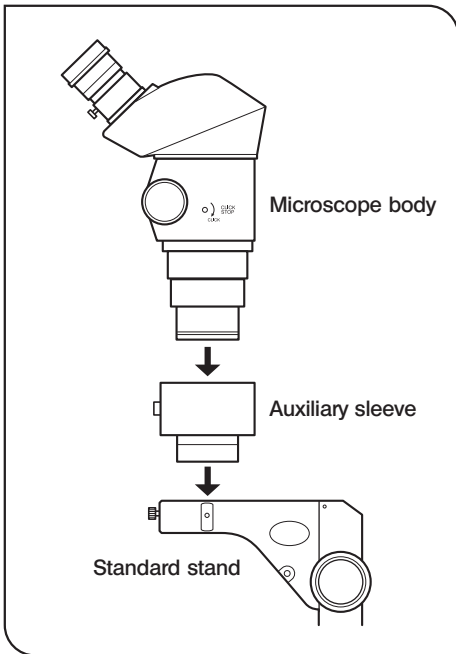

Fig. 11

3 Using Auxiliary Sleeve SZ2-ET

(Fig. 11)

As the 0.5X objective has a long working distance, it cannot be used in combination with the standard stand unless the auxiliary sleeve is used.

★ When the auxiliary sleeve is used, the microscope becomes tall and unstable. Care is therefore needed against toppling it down.

4-4 TV Observation and Photomicrography

©When TV observation or photomicrography is required, use the SZX-TR30 trinocular tube.

A TV camera and/or digital camera unit can be mounted on the SZX-TR30 trinocular tube by means of the TV adapter and/or camera mount adapter*.

* The camera mount adapter is not necessary if a TV adapter equipped with a camera mount is used.

For details, please also read the instruction manuals for the TV adapter and digital camera.

1 Selecting the TV Adapter Magnification

Set the magnification of the TV adapter according to the size of the CCD in the TV camera or digital camera.

The following figures show the TV observation areas when the WHSZ10X eyepieces with FN 22 are used.

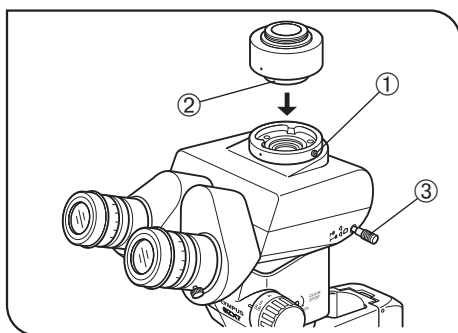
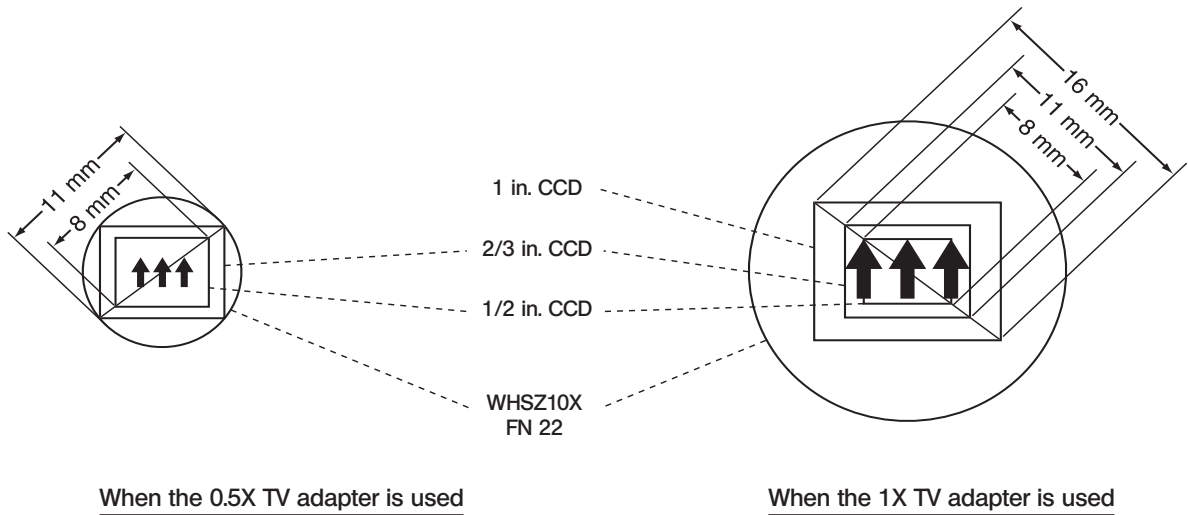

Fig. 12

2 Mounting the TV Adapter

(Fig. 12)

1. Using the Allen screwdriver, fully loosen the straight tube clamping screw ① of the straight tube mount on the top of the trinocular tube.
2. Fit the round dovetail ② of the TV adapter into the straight tube mount of the trinocular tube, and tighten the clamping screw ①.
3. Mount the TV camera on the TV adapter. A camera mount adapter may be required with certain TV adapters.

3 Selecting the TV Camera Light Path

(Fig. 12)

Pull out the light path selector knob ③ to select the Binocular 20%/TV & Photo 80% light path setting.

5 TROUBLESHOOTING GUIDE

Under certain conditions, performance of the microscope may be adversely affected by factors other than defects. If problems occur, please review the following list and take remedial action as needed. If you cannot solve the problem after checking the entire list, please contact Olympus.

Problem	Cause	Remedy	Page
1. The left and right fields of view do not coincide.	Interpupillary distance is adjusted improperly.	Adjust it correctly.	6
	The parallax is not corrected.	Adjust it correctly.	7
	The left and right eyepieces are different.	Use eyepieces with the same magnifications for the left and right by replacing one of them.	3
2. The edge of the field of view is obscured or not evenly illuminated.	The aperture iris diaphragm is stopped down (when the SZX-AS is used).	Open the aperture iris diaphragm.	20
	The binocular tube and/or intermediate attachment are installed improperly.	Install them properly.	17
	The light path selector knob is in an intermediate position. (SZX-TR30)	Set it properly.	9
3. Dirt or dust is visible in the field of view.	Dirt/dust on specimen.	Clean thoroughly.	2
	Dirt/dust on eyepieces		
4. Details of observed image are solid.	The aperture iris diaphragm is stopped down (when the SZX-AS is used).	Open the aperture iris diaphragm.	20
5. Visibility of observed image is poor. • Image is not sharp. • Contrast is poor.	The objective is tilted.	Screw it in correctly until it stops.	17
	The objective is dirty.	Clean thoroughly.	2
	The top and/or bottom lenses of the microscope body are dirty.		
	The bottom lens of the observation tube is dirty.		
6. Zooming causes defocusing of the observed image.	The eyepiece diopter is adjusted improperly.	Adjust it correctly.	7
	The focus adjustment is inaccurate.	Adjust the focus accurately.	7
7. The focus adjustment knob does not rotate smoothly.	The rotation tension of the knob is set too high.	Decrease the rotation tension to an optimum level.	6
8. The microscope body drops spontaneously, causing the focusing to be deviated during observation.	The rotation tension of the knob is set too low.	Increase the rotation tension to an optimum level.	6

6 SPECIFICATIONS

Item	Specifications		
1. Zoom microscope body. • SZX-ZB7	Zoom magnification variation: Left/right optical axis parallel method. Zoom drive: Horizontal knob system. Click stop for each zoom magnification: ON-OFF switching possible. <hr/> Zoom ratio values: 7 values (0.8X to 5.6X) Zoom magnification indication: 0.8, 1, 1.25, 1.6, 2, 2.5, 3.2, 4, 5, 5.6 <hr/> Objective mounting: Screw mounting into thread. <hr/> Aperture iris diaphragm control: Possible using the AS unit (SZX-AS).		
2. Observation tube • SZX-BI45 • SZX-TBI • SZX-TR30	SZX-BI45	SZX-TBI	SZX-TR30
	Binocular tube	Tilting binocular tube	Trinocular tube
	Tilting angle: 45°	Tilting angle: 5° to 45°	Tilting angle: 30°
	—		Light path selection: 2 steps (Binocular 100%, TV & Photo 80%/Binocular) 20%
	Interpupillary distance adjustment range: 50 to 76 mm		
	Eyepiece clamping knobs provided. Eyepieces: WHSZ series eyepieces.		
3. Standard stand • SZ2-ST	Rack-and-pinion using ball guide. Knob rotation tension adjustable. Focusing stroke 120 mm. Stage plate: Diameter 100 mm. Oblique illumination system (LSGA) mountable. Transmitted light illumination stand (SZ2-ILA) mountable.		
4. Objectives * The SZ2-ET auxiliary sleeve is required when the SZ2-ST is used.	Model		Working Distance
	DFPL0.5X-4		171 mm*
	DFPL0.75X-4		116 mm
	DFPLAPO1X-4		81 mm
	SZX-ACH1X		90 mm
	SZX-ACH1.25X		68 mm
	DFPL1.5X-4		45.5 mm
	DFPL2X-4		33.5 mm
5. Eyepieces * An eyepiece micrometer disk with a diameter of 24 mm and thickness of 1.5 mm can be inserted. (The disk area outside the field number is invisible.)	WHSZ10X FN 22 * WHSZ10X-H FN 22, with diopter adjustment ring * WHSZ15X-H FN 16, with diopter adjustment ring WHSZ20X FN 12.5 * WHSZ20X-H FN 12.5, with diopter adjustment ring * WHSZ30X-H FN 7, with diopter adjustment ring		
6. Operating environment	<ul style="list-style-type: none"> • Indoor use • Altitude: Max. 2000 m • Ambient temperature: 5° to 40°C (41° to 104°F) • Maximum relative humidity: 80% for temperatures up to 31°C (88°F), decreasing linearly through 70% at 34°C (93°F), 60% at 37°C (99°F), to 50% relative humidity at 40°C (104°F) 		

7 OPTICAL PERFORMANCE

Objective	Eyepieces							
	WHSZ10X/10X-H		WHSZ15X-H		WHSZ20X/20X-H		WHSZ30X-H	
	Total Magnification	Actual Field (mm)	Total Magnification	Actual Field (mm)	Total Magnification	Actual Field (mm)	Total Magnification	Actual Field (mm)
DFPL 0.5X-4	4X - 28X	55 - 7.8	6X - 42X	40 - 5.7	8X - 56X	31.3 - 4.5	12X - 84X	17.5 - 2.5
DFPL 0.75X-4	6X - 42X	36.7 - 5.2	9X - 63X	26.7 - 3.8	12X - 84X	20.8 - 3.0	18X - 126X	11.7 - 1.7
DFPLAPO 1X-4	8X - 56X	27.5 - 3.9	12X - 84X	20 - 2.9	16X - 112X	15.6 - 2.2	24X - 168X	8.8 - 1.3
SZX-ACH 1X	8X - 56X	27.5 - 3.9	12X - 84X	20 - 2.9	16X - 112X	15.6 - 2.2	24X - 168X	8.8 - 1.3
SZX-ACH 1.25X	10X - 70X	22 - 3.1	15X - 105X	16 - 2.3	20X - 140X	12.5 - 1.8	30X - 210X	7.0 - 1.0
DFPL 1.5X-4	12X - 84X	18.3 - 2.6	18X - 126X	13.3 - 1.9	24X - 168X	10.4 - 1.5	36X - 252X	5.8 - 0.83
DFPL 2X-4	16X - 112X	13.8 - 1.9	24X - 168X	10-1.4	32X - 224X	7.8 - 1.1	48X - 336X	4.4 - 0.63

8 ASSEMBLY

8-1 Assembly Diagram

The diagram below shows the sequence of assembly of the various modules. The numbers indicate the order of assembly.

Assembly steps enclosed in **■** will be detailed on the subsequent pages.

★ When assembling the microscope, make sure that all parts are free of dust and dirt, and avoid scratching any parts or touching glass surfaces.

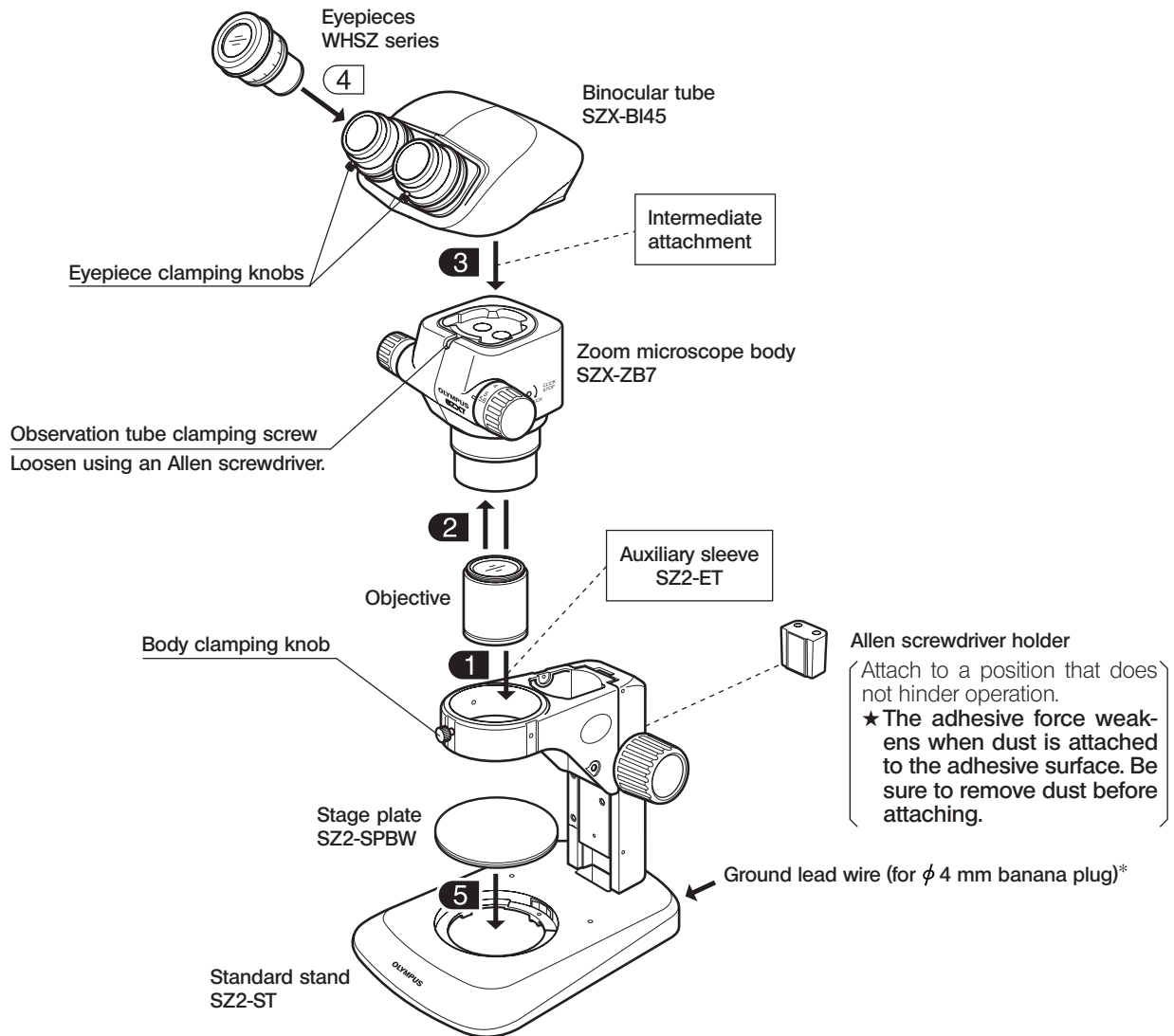

Tools Required

Allen screwdriver
(Provided with the zoom microscope body)



* To utilize the ESD protection performance, be sure to ground the equipment using a grounding lead wire having a 4 mm banana plug.

8-2 Detailed Assembly Procedures

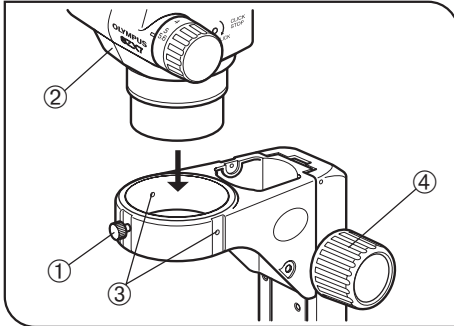

Fig. 13

1 Installing the Microscope Body (Fig. 13)

1. Loosen the body clamping knob ① and insert the microscope body ② gently into the mounting hole of the standard stand.
Ⓞ The body clamping knob ① can be attached to any of the accessory mounting screw holes ③ around the mounting hole. It may be necessary to change the knob position when a module such as an illumination system is mounted.
2. Position the microscope body so that it faces forward and tighten the body clamping knob ①.
Ⓞ If it is required to position the zoom adjustment knob near the focus adjustment knob ④, position the microscope body in the opposite orientation.

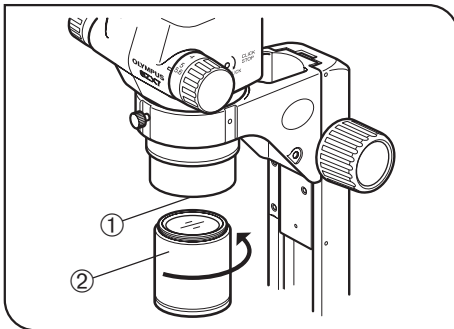

Fig. 14

2 Mounting the Objective (Fig. 14)

- Attach the objective ② to the objective mount thread ① by turning the objective in the direction of the arrow.
- Ⓞ The SZ2-ET auxiliary sleeve is required when the 0.5X objective is used.

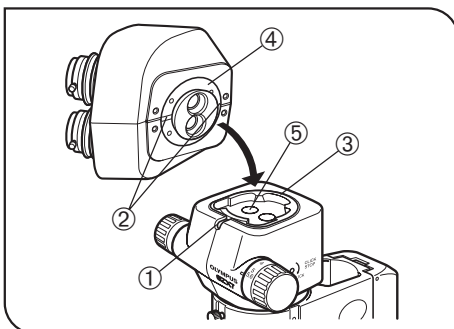

Fig. 15

3 Mounting the Observation Tube (Fig. 15)

1. Using the Allen screwdriver, fully loosen the observation tube clamping screw ①.
 2. Aligning the positioning groove ② of the observation tube with the positioning pin ③ of the microscope body, fit the dovetail ④ at the bottom of the observation tube into the dovetail mount ⑤ of the microscope body.
 3. Tighten the observation tube clamping screw ① firmly using the Allen screwdriver.
- ★ If you always perform observation from the side of the focus adjustment knobs, the microscope body can be installed in the opposite orientation to that shown in the figure (at the 180° rotated position).

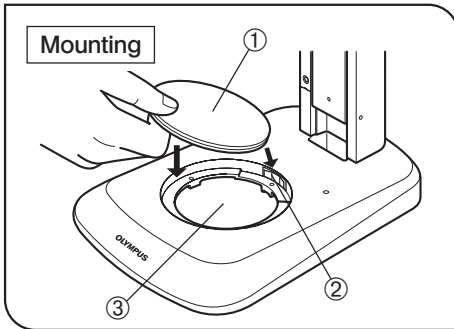

Fig. 16

5 Mounting the Stage Plate

(Figs. 16 & 17)

1. While applying the stage plate ① to the stage plate holder spring ②, fit the stage plate into the stage plate mounting hole ③.
- Ⓞ The stage plate has the milky white and black surfaces. Select the side facing up according to the specimen.
2. To dismount the stage plate, push the stage plate edge near the holder spring ②. As this moves up the opposite edge of the stage plate, dismount it by holding that edge.

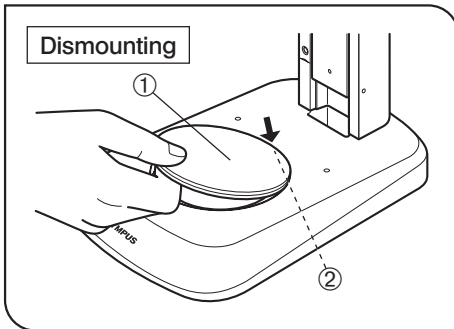
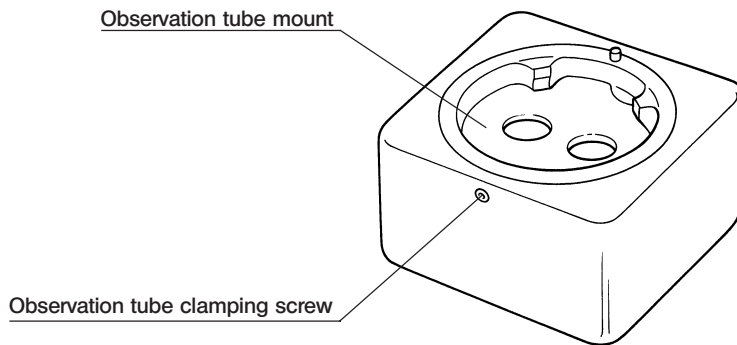

Fig. 17

9 OPTIONAL MODULES

9-1 Eye Point Adjuster SZX-EPA

1 External View and Nomenclature



2 Installation

(Fig. 18)

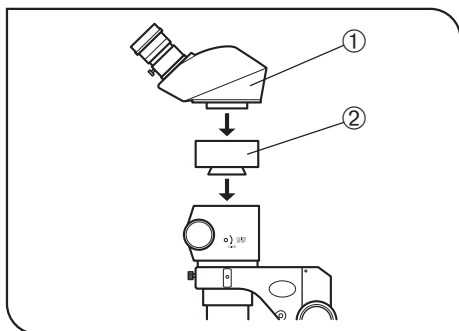
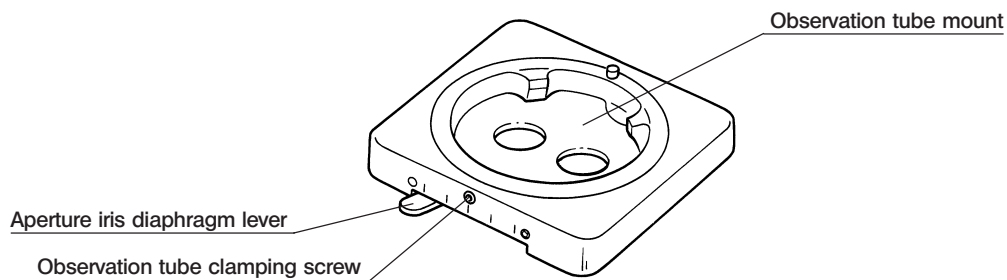

Fig. 18

1. Remove the observation tube ① using the Allen screwdriver provided with the SZX microscope body.
 2. Attach the eye point adjuster ② to the position where the observation tube has been attached.
 3. Attach the observation tube above the eye point adjuster. This raises the eye point by 40 mm.
- Up to two eye point adjusters can be stacked provided that no other intermediate attachment is used.

9-2 AS Unit SZX-AS (For the SZX-ZB7/ZB9)

1 External View and Nomenclature



2 Installation

©The AS unit can be attached in the same way as the SZX-EPA eye point adjuster.

3 Using the Aperture Iris Diaphragm

⊙ Adjusting the aperture iris diaphragm makes it possible to improve the contrast of the observation image and increase the focal depth.

However, the resolution is degraded when the aperture iris diaphragm is stopped down.

- Slide the aperture iris diaphragm lever.

Slide toward the left ○ to open the aperture iris diaphragm and toward the right ⊗ to close it. Adjust while observing the image to confirm the effects on the contrast and focal depth.

★ **Stopping down the aperture iris diaphragm too much may degrade resolution or cause an insufficiency in the peripheral brightness. This insufficiency tends to occur particularly at high zoom magnifications.**

★ **When the SZX-ILLC coaxial illuminator is used, stopping down the aperture iris diaphragm to the minimum may cut off part of image. In this case, open the aperture iris diaphragm to an intermediate position.**

9-3 BX Stage Adapter Type 1 SZX-STAD1

1 Introduction

The SZX-STAD1 is an adapter for use in mounting the U-SRG or U-SRP rotary stage on the SZ2-ST standard stand, SZX-ST standard stand, large stand or SZX illumination stand. The U-SRP is used in combination with the U-FMP mechanical stage to enable movement in the X- and Y-directions, which is convenient for framing in photomicrography or TV observation. To compensate for the height of the stage adapter, it is recommended to use also the SZ2-ET auxiliary slave when the SZ2-ST is used or the SZH-P400 auxiliary column (and the SZX-R drop prevention ring also) when the SZX-ST or SZX illumination stand is used.

2 Applicable Stands and Restrictions

Stands	Applicable Objectives	Restrictions
<ul style="list-style-type: none"> • Standard stand SZ2-ST SZX-ST • Large stand SZ-STL SZX-STL 	0.5X to 2X	None
<ul style="list-style-type: none"> • Transmitted illumination stand SZ2-ILA 	Peripheral part of image is cut off at low magnifications.	The SZ2-ST is also required.
<ul style="list-style-type: none"> • Transmitted illumination stand SZX-ILLK • High-class transmitted illumination stand SZX-ILLB2 • Transmitted brightfield/darkfield illumination stand SZX-ILLD2 	<p>The restrictions are identical whether or not the stage adapter is used. (Refer to the instruction manual for the SZX illumination stand.)</p> <p>The transmitted light illumination field may be limited depending on the diameter of the hole on the stage center plate in use.</p> <p>★ Darkfield observation is not available with the SZX-ILLD2.</p> <p>★ The brightness drops when a frost filter is used.</p>	

3 Installation

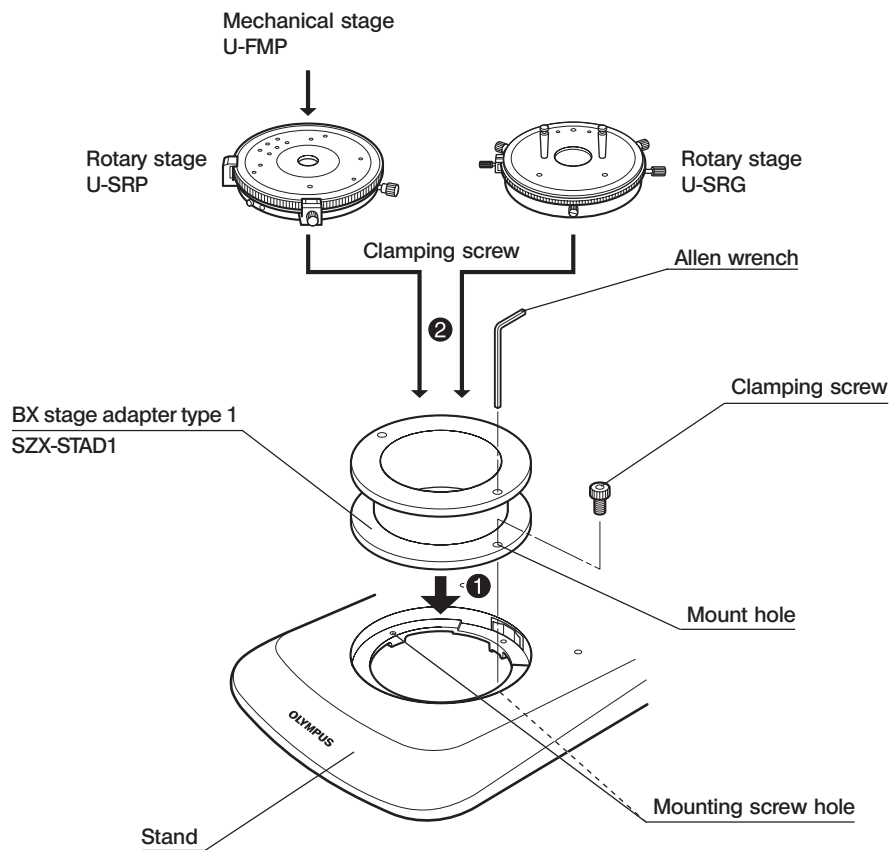

Mounting the polarizer (SZX-PO or SZ-POL-2)

When simplified transmitted light polarized observation is required, mount the polarizer on the BX stage adapter type 1 (SZX-STAD1).

Drop the polarizer body into the polarizer mount at the top of the SZX-STAD1.

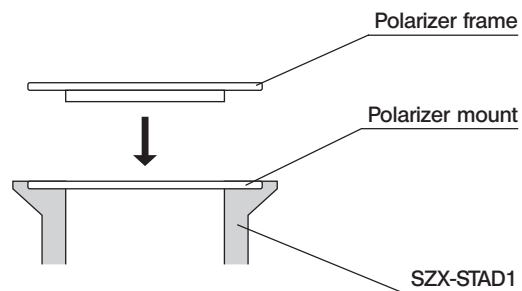

9-4 Stage Adapter Type 1 SZH-STAD1

The SZH-STAD1 is an adapter providing the similar function to the BX stage adapter type 1 (SZX-STAD1). The difference is that the stage usable for the SZH-STAD1 is the BH2-SH horizontal knob stage.

The installation and polarizer (SZX-PO or SZ-POL-2) mounting methods are identical to those for the SZX-STAD1. Please read the previous section (page 21).

9-5 Up/Down Moving Stage SZ2-FO

1 Associated Module System Chart

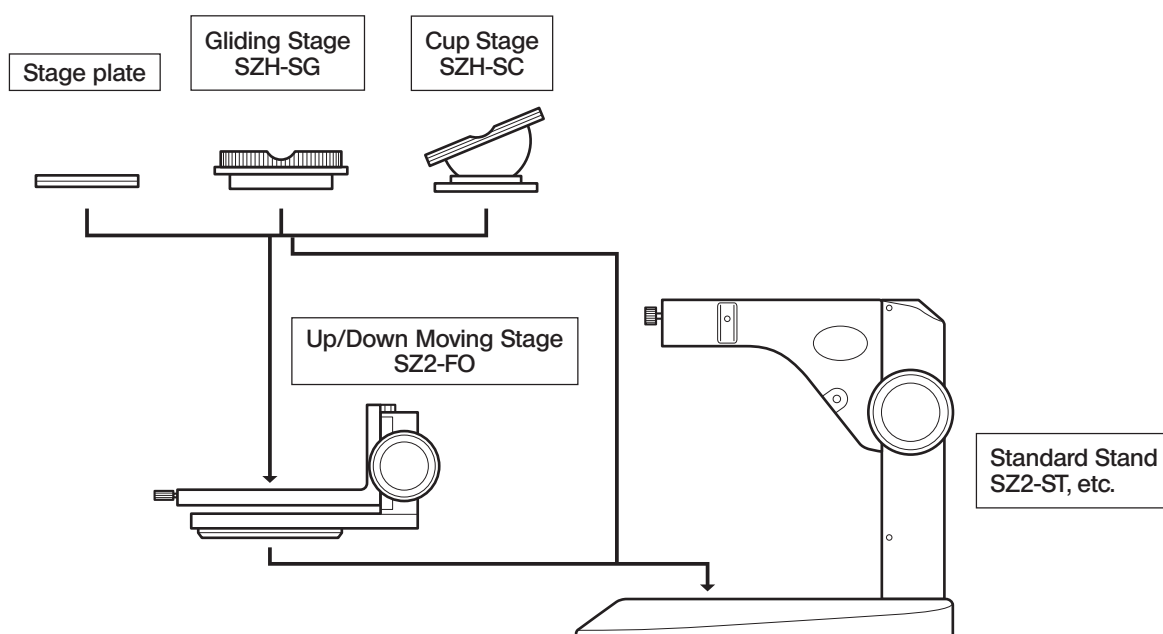

◎ When using a filter or simplified polarized light system in combination with the transmitted illumination stand, mount the filter holder or polarizer on the stand before installing the up/down moving stage.

◎ The up/down moving stage can also be mounted so that the focus adjustment knob comes on the side of the observer (180° opposite to the orientation shown in the above figure).

Modules Mountable on the SZ2-FO

- Stage plate : SZ2-SPBW, SP-C
- Stand : SZ2-ST, SZX-ST, SZ-STL, SZX-STL, SZX illumination stand series
- Stage : SZH-SC, SZH-SG*

* The front/rear movement is possible only on the front side of the center because the focus adjustment knobs of the SZ2-FO come in the way.

2 External View and Nomenclature

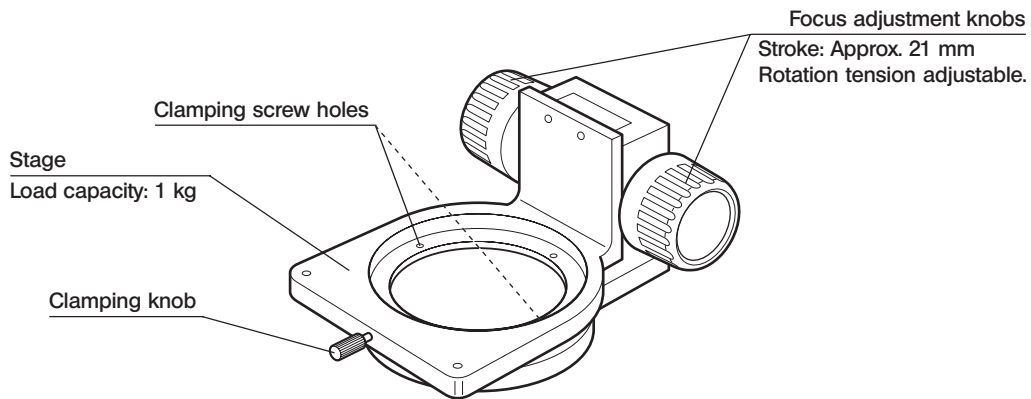

3 Installation

- Using the provided screw and Allen wrench, attach the SZ2-FO up/down moving stage into the screw hole on the stage plate mount hole of an applicable stand or that on the stage plate (SZ-STL).
The SZ2-FO can also be installed so that the focus adjustment knobs are located on the near side of the operator. This orientation is obligatory when the IHE holder for the LSGA oblique illumination system is used.
- Loosen the clamping knob on the stage, attach the stage plate, SZH-SG or SZH-SC, and tighten the clamping knob again.

4 Operation

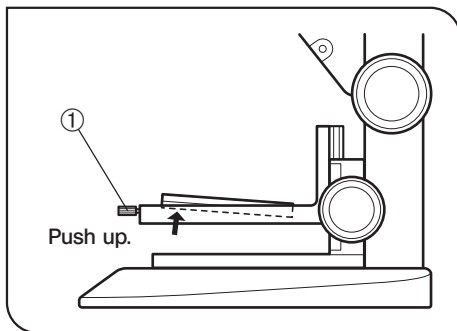

Fig. 19

Removing the stage plate (Fig. 19)

To remove the stage plate, loosen the clamping knob ① and push up the stage plate from below it.

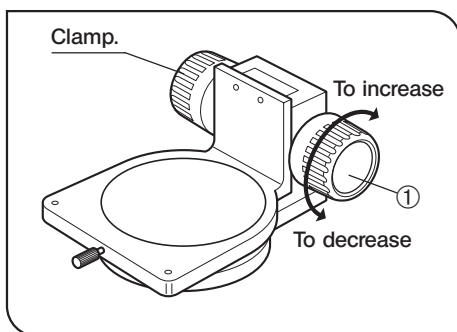

Fig. 20

Adjusting the focus adjustment knob tension (Fig. 20)

Ⓞ This operation is intended to facilitate the rotation of the knobs while preventing spontaneous drop of the up/down moving stage. It is recommended to set the knob tension to a slightly higher level than the point where spontaneous drop occurs.

- Hold the left and right focus adjustment knobs ① with both hands, fix the left knob and rotate the right knob. The rotation tension of the knobs increases or decreases according to the direction in which the right knob is rotated.
- If the rotation tension is increased too much, accurate focusing is not possible and the mechanism may be damaged.

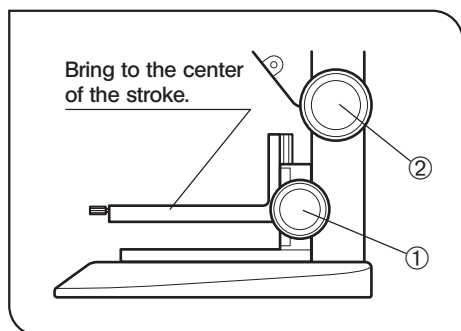

Fig. 21

Adjusting the focus (Fig. 21)

1. Rotate the focus adjustment knob ① of the SZ2-FO up/down moving stage to bring the stage at the center of the focusing stroke.
2. Place a specimen on the stage and rotate the focus adjustment knob ② on the side of the stand in use to bring the specimen into approximate focus. And then adjust the accurate focus using the focus adjustment knob ① of the up/down moving stage.

5 Applicable Stands and Restrictions

Stands	Applicable Objectives	Restrictions
<ul style="list-style-type: none"> • Standard stand SZ2-ST SZX-ST • Large stand SZ-STL SZX-STL 	0.5X to 1.5X	None
<ul style="list-style-type: none"> • Transmitted illumination stand SZ2-ILA 	Peripheral part of image is cut off at low magnifications.	The SZ2-ST is also required.
<ul style="list-style-type: none"> • Transmitted illumination stand SZX-ILLK • High-class transmitted illumination stand SZX-ILLB2 • Transmitted brightfield/darkfield illumination stand SZX-ILLD2 	The restrictions are identical whether or not the stage adapter is used. (Refer to the instruction manual for the SZX illumination stand.) The transmitted light illumination field may be limited depending on the diameter of the hole on the stage center plate in use. ★ Darkfield observation is not available with the SZX-ILLD2. ★ The brightness drops when a frost filter is used.	

9-6 Gliding Stage SZH-SG

1 External View and Nomenclature

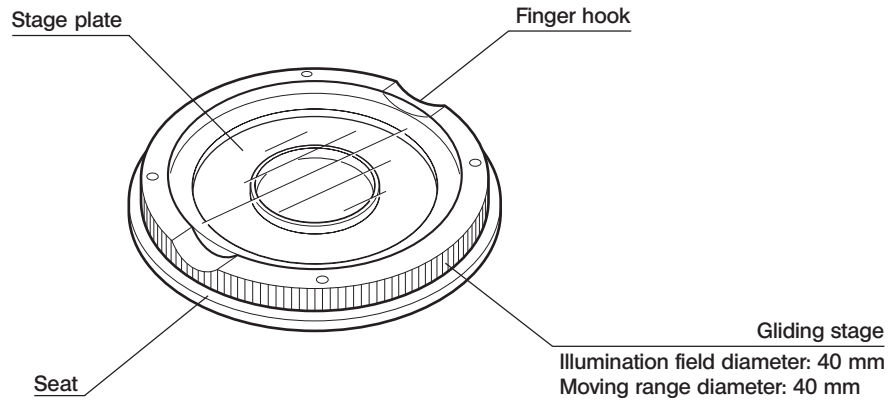

2 Installation

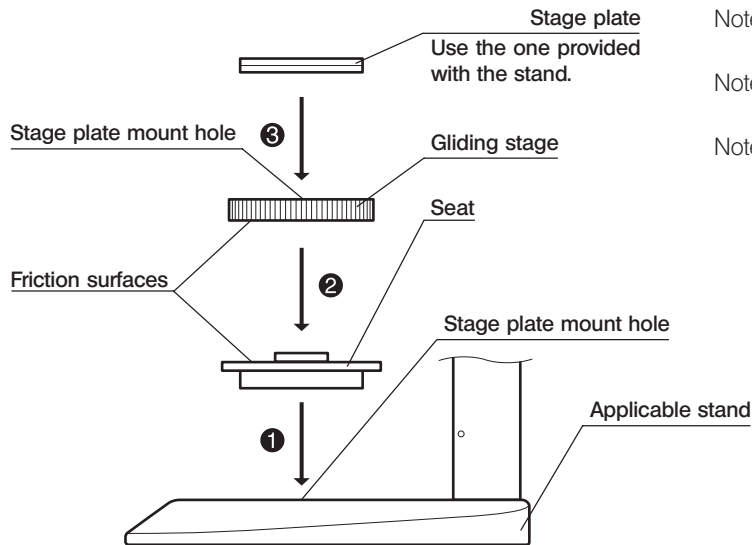

- Note 1) Be sure to clean the friction surfaces if dirt or metallic power is attached on them.
- Note 2) Do not place the gliding stage on the friction surface directly on the desktop.
- Note 3) Clean the friction surfaces periodically.

3 Operation

Hold the gliding stage by the edge and move it horizontally.

9-7 Cup Stage SZH-SC

1 External View and Nomenclature

★The SZH-SC can be used only with reflected light illumination. It cannot be used with transmitted light illumination.

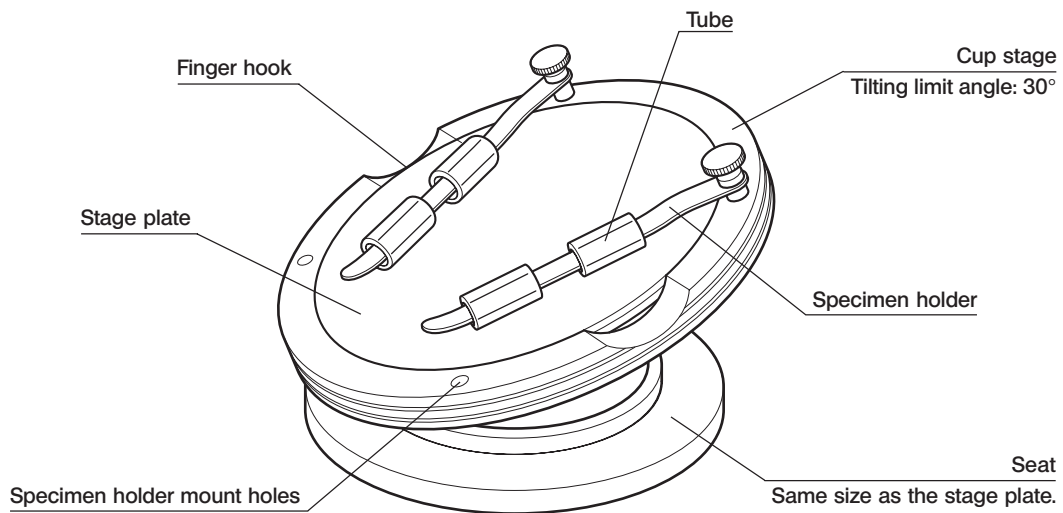

2 Installation

★ Before mounting, remove dirt and dust from the mount surfaces and handle carefully so as not to damage them.

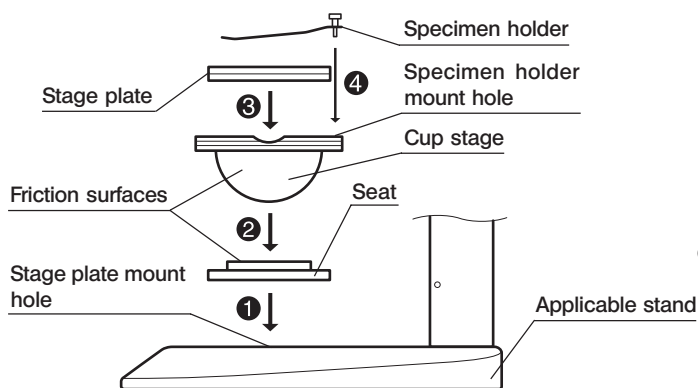

- ① Fit the cup stage seat into the stage plate mount hole of an applicable stand.
 - ② Place the cup stage on the seat. Before placing, wipe the friction surfaces on the cup stage and seat with a clean cloth.
 - ③ Mount the stage plate.
 - ④ Mount the specimen holder.
- Ⓢ Clean the friction surfaces periodically.

3 Operation

(Figs. 22 & 23)

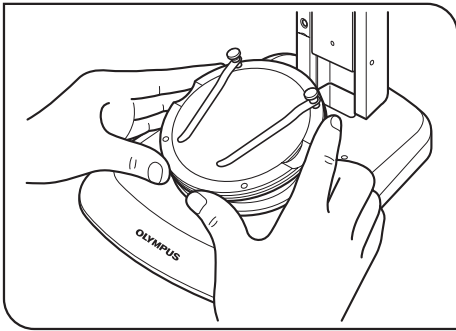

Fig. 22

Place a specimen on the stage plate, hold the cup stage by the edge, and tilt the cup stage slowly. (Fig. 22)

Ⓢ If the specimen slips on the stage plate, hold the specimen with the provided specimen holder.

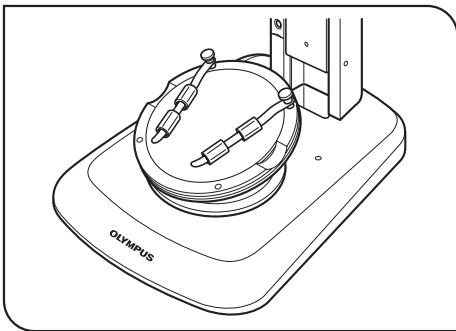

Fig. 23

Ⓢ To fix a container such as a petri dish, insert the provided tube into the specimen holder to fix the container by pinching. (Fig. 23)

CAUTION

1. Do not touch the friction surfaces on the cup stage and seat with a hand. If the friction surfaces are contaminated with oil, etc., wash with a neutral detergent before use.
2. If an eccentric load of more than 20 grams is applied to the edge of the cup stage, it may move spontaneously.
3. When a tall specimen is placed and the cup stage is tilted, the specimen may go out of focus. In this case, adjust the focus again.

OLYMPUS®



OLYMPUS CORPORATION

Shinjuku Monolith, 3-1, Nishi Shinjuku 2-chome, Shinjuku-ku, Tokyo, Japan



OLYMPUS EUROPA HOLDING GMBH

Wendenstraße 14-18, 20097 Hamburg, Germany

OLYMPUS AMERICA INC.

3500 Corporate Parkway, P.O. Box 610, Center Valley, PA 18034-0610, U.S.A.

OLYMPUS SURGICAL & INDUSTRIAL AMERICA INC.

One Corporate Drive, Orangeburg, NY 10962, U.S.A.

OLYMPUS SINGAPORE PTE LTD.

491B River Valley Road, #12-01/04 Valley Point Office Tower, Singapore 248373

OLYMPUS AUSTRALIA PTY. LTD.

31 Gilby Road, Mount Waverley, VIC., 3149, Australia

OLYMPUS LATIN AMERICA, INC.

5301 Blue Lagoon Drive, Suite 290 Miami, FL 33126, U.S.A.

