

# Electronic Keyboard

# INSTRUCTION MANUAL

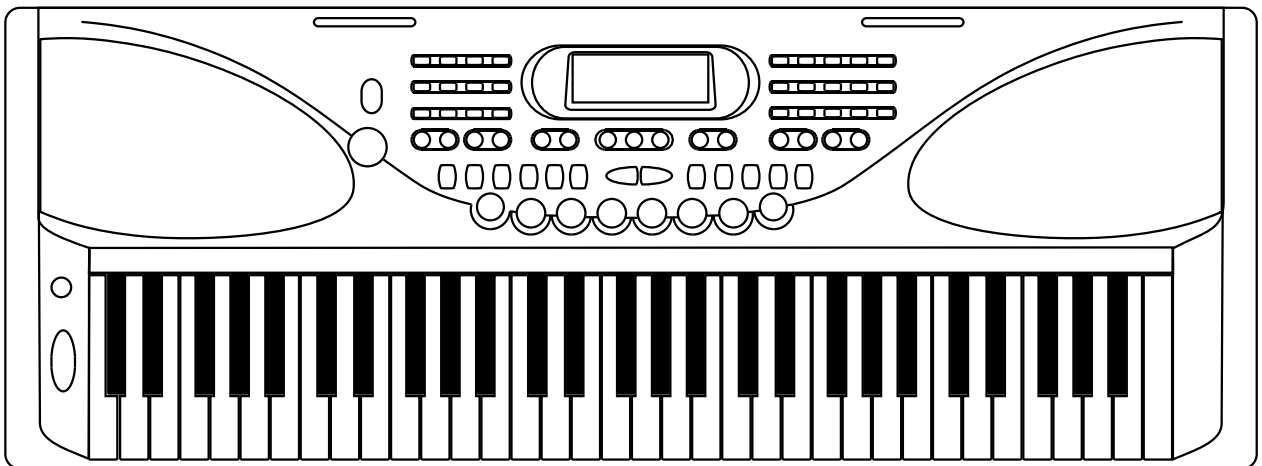

# Congratulations

Congratulations on your purchase of this professional electronic keyboard.

The keyboard is an easy-to-use keyboard with advanced functions especially designed for in self-learning players and beginners, users can learn playing songs in 3 different ways. The LCD display makes it easier for users to learn how to play songs in a more directive way.

You are recommended to study this manual carefully before using the unit.

## Inside This Package

Please make sure the package completely contains the following:

- **The Instrument**

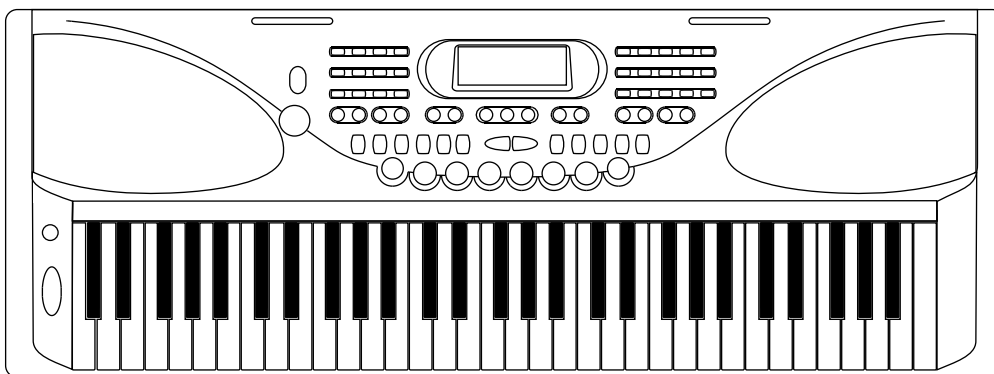

- **Music Stand**

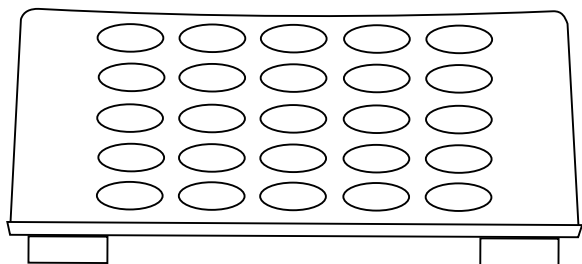

- **Instruction Manual**

- **12V Adaptor**



## Important Notes

Your keyboard will give you years of playing pleasure if you follow the simple rules given below:

### Location

---

- Do not expose the unit to the following conditions to avoid deformation, discoloration, or more serious damage.
  - ( Direct sunlight.
  - ( High temperature (near a heat source, ( or in a car during the day time).
  - ( Excessive humidity.
  - ( Excessive dust.

### Power Supply

---

- Make sure to use the suitable AC adaptor, and also make sure the AC outlet voltage at your country matches the input voltage specified on the AC adaptor's label.
- Turn the power switch OFF when the instrument is not in use.
- An AC adaptor should be unplugged from the AC outlet if the instrument will not be used for an extended period of time.
- Unplug the AC adaptor during electric storms.
- Avoid plugging the AC adaptor into the same AC outlets as appliances with high power consumption, such as electric heaters or ovens. Also avoid using multi-plug adaptors since this could reduce sound's quality, causes operation errors and damages.

### Turn Power OFF When Making Connections

---

- To avoid damaging the instrument and other devices to which it is connected, turn the power switches of all related devices OFF prior to connecting or disconnecting cables.

### Cleaning

---

- Clean the unit with a soft dry cloth.
- A slightly dampened cloth may remove stubborn grime and dirt.
- Never use cleaners such as alcohol or thinner.
- Avoid placing vinyl object on top of the unit (vinyl might discolor and stick to the surface).

### Handling and Transporting

---

- Never apply excessive force to the controls, connectors or other parts of the instrument.
- Always unplug cables by gripping the plug firmly, but not pulling the cables.
- Disconnect all cables before moving the instrument.
- Physical shocks caused by dropping, bumping, or placing heavy objects on the instrument could result in scratches or even severe damages.

### Electrical Interference

---

- This instrument contains digital circuitry and may cause interference if it is placed too close to radio or television receivers. If this occurs, move the instrument further away from the receivers.

# Main Features

- **KEYBOARD**

61-key touch keyboard

- **OPERATION**

Use the Direct Select Button to select "Voices" and "Styles" more conveniently.

- **VOICE**

138 voices in total, including 128 GM Voices, 8 Chinese Voices and 2 Percussion Voices.

- **STYLE**

100 styles in total.

- **SONG**

50 songs in total. Each song has its learning mode.

- **CHORD MODE**

Both Single finger chords and Fingers chords.

- **CHORD DICTIONARY**

Provide chord information for users.

- **MEMORY FEATURE**

Contains 6 memory registers.

- **STYLE CONTROL**

Sync ㊦ Start/Stop ㊦ Fill In A/Normal ㊦ Fill In B/Variation ㊦ Intro/Ending

- **OTHER FEATURES**

Dual, Sustain, O.T.S., Record, Demo, Transpose, Octave, Pitchbend wheel, DSP, USB and etc.

**NOTE:**

Press and hold ▽+▼ and ▽-▼ together and to turn the power on simultaneously; the default setting will be loaded into the keyboard, and the memory will be lost.

# Contents

<b>General Guide</b> .....	<b>5-6</b>	<b>Memory</b> .....	<b>22</b>
△ Front Panel.....	5-6	△ Memory Bank.....	22
△ Rear Panel.....	6	△ Memory Data.....	22
△ LCD Display.....	6		
<b>Preparation</b> .....	<b>7-8</b>	<b>One Touch Setting</b> .....	<b>23</b>
△ Power Supply.....	7		
△ Setting the Music Stand.....	8	<b>Record</b> .....	<b>24</b>
		△ Start Record.....	24
<b>Connections</b> .....	<b>8-9</b>	△ Stop Record.....	24
△ Headphone Jack.....	8	△ Playback Record.....	24
△ AUX.OUT Jack.....	8-9		
△ Sustain Jack.....	9	<b>Song</b> .....	<b>25</b>
△ USB Jack.....	9	△ LESSON.....	25-27
<b>Basic Operation</b> .....	<b>10</b>		
△ Power Switch & Volume.....	10	<b>Chord Dictionary</b> .....	<b>28-29</b>
△ Demo.....	10		
<b>Voices and Effects</b> .....	<b>11-14</b>	<b>MIDI Function</b>	<b>30-32</b>
△ Select a Voice.....	11	△ What is MIDI.....	30
△ Dual Voice.....	11-12	△ USB Connection.....	30
△ Sustain.....	12	△ MIDI Application.....	31-32
△ DSP Effect.....	12		
△ Pitch Bend.....	13	<b>Specifications</b> .....	<b>33</b>
△ Modulation.....	13		
△ Touch.....	13	<b>Trouble Shooting</b> .....	<b>33</b>
△ Transpose.....	14		
△ Octave.....	14	<b>Appendix</b> .....	<b>34-38</b>
<b>Style Control</b> .....	<b>15-21</b>	△ Appendix 1 - Voice List.....	34
△ Select a Style.....	15	△ Appendix 2 - Style List.....	35
△ Start a Style.....	15	△ Appendix 3 - Song List.....	36
△ Stop a Style.....	16	△ Appendix 4 - Chord List.....	37
△ Intro/Ending.....	17	△ Appendix 5 - MIDI List.....	38
△ Fill A/B.....	17		
△ Tempo.....	18		
△ Accomp Volume.....	19		
△ Chord Recognize.....	20-21		

# General Guide

## Front Panel

### 50 SONGS

- 01-37 CLASSICAL
- 38-50 PIANIST

### 100 STYLES

- 01-15 8/16 BEAT
- 16-22 BALLAD
- 23-29 ROCK
- 30-34 DANCE
- 35-42 SWING & JAZZ
- 43-46 RHYTHM & BLUES

- 47-52 COUNTRY
- 53-64 LATIN
- 65-73 BALL ROOM
- 74-85 TRADITIONAL
- 86-89 PIANIST
- 90-99,00 ORIENTAL

### 3 STYLES

01 8 BEAT 1	16 SLOW BALLAD	23 HARD ROCK	30 DISCO 1
11 16 BEAT FLNK	22 BLUES BALLAD	29 4/4 BLUES	34 TECHNO
35 BIG BAND ROOGIE	43 R & B 1	47 COUNTRY POP	53 JAZZ SAMBA
42 JAZZ TRIO	46 SOUL SHUFFLE	52 BLUE GRASS	63 REGGAE
65 TANGO	74 MARCH	86 PIANIST	90 DANGDUT
72 QUICK STEP	80 WALTZ 1	88 SLOW ROCK 2	94 YUN NAN

**POWER** 1

ON

OFF

**VOLUME** 2

**ACC.VOL** 4      **TEMPO** 5

**CHORD DICTIONARY** 12      **LESSON** 13

**VOICE** 14      **STYLE** 15      **SONG** 16

**M1** 19      **ONE TOUCH** M2      **SETTING** M3      **M4**      **M5**      **M6**

**STORE** 18      **START/STOP** 6      **SYNC** 7      **INTRO/ENDING** 8      **FILL-IN A** 9

**VOICE** 17

### 20 VOICES

01 GRAND PNO	08 CLAVI	20 CHURCH ORG	23 HARMONICA	33 ACOUSTIC BASS
06 E. PIANO 2	12 VIBRAPHONE	22 ACCORDION	25 NYLON GTR	41 VIOLIN
43 CELLO	49 STRING 1	53 CHOIR AAHS	57 TRUMPET	62 BRASS ENSEMBLE
47 HARP	50 STRING 2	56 ORCH HIT	61 HORN	66 ALTO SAX
67 TENOR SAX	72 CLARINET	129 PI PA	132 ER HU	137 STD DRUM
69 OBOE	74 FLUTE	130 GU ZHENG	135 QU DI	138 C.PERCUS

### 138 VOICES

- 01-08 PIANO
- 09-16 MALLET
- 17-24 ORGAN
- 25-32 GUITAR
- 33-40 BASS
- 41-48 STRINGS
- 49-56 ENSEMBLE
- 57-64 BRASS
- 65-72 REED
- 73-80 PIPE
- 81-88 LEAD
- 89-96 PAD
- 97-104 EFFECTS
- 105-112 ETHNIC
- 113-120 PERCUSSIVE
- 121-128 SOUND EFFECTS
- 129-136 CHINESE INSTRUMENT
- 137-138 DRUM SET

**RECORD**      **PLAY/STOP**

**DUAL**      **TOUCH**      **SUSTAIN**      **BSP**      **DEMO**

**FILL-IN B**      **A.B.C.**      **O.T.S.**

**GENERAL midi**      **TOUCH RESPONSE**

- 1 POWER ON/OFF
- 2 MASTER VOLUME
- 3 STYLES DIRECT SELECTED
- 4 ACCOMPANIMENT VOLUME -/+
- 5 TEMPO -/+
- 6 START/STOP
- 7 SYNC
- 8 INTRO/ENDING
- 9 FILL-IN A
- 10 FILL-IN B
- 11 AUTO BASS CHORD
- 12 CHORD DICTIONARY
- 13 LESSON
- 14 VOICE
- 15 STYLE
- 16 SONG
- 17 -/+ BUTTON
- 18 STORE
- 19 ONE TOUCH SETTING
- 20 PANEL MEMORY M1-M6
- 21 DUAL
- 22 TOUCH
- 23 SUSTAIN
- 24 DSP
- 25 DEMO
- 26 TRANPOSE -/+
- 27 OCTAVE -/+
- 28 RECORD
- 29 PLAY/STOP
- 30 MODULATION
- 31 PITCHBEND

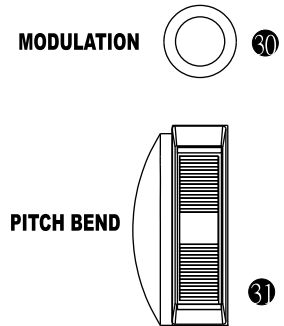

## Rear Panel

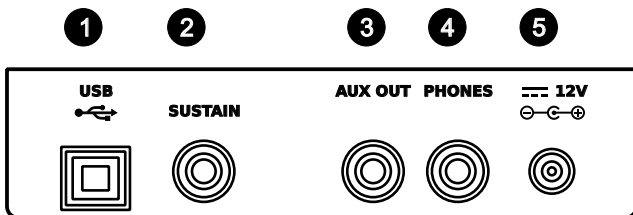

- 1 USB JACK
- 2 SUSTAIN JACK
- 3 AUX OUT JACK
- 4 PHONES JACK
- 5 12V JACK

## LCD Display

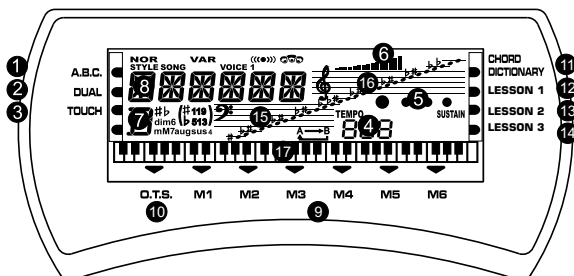

- 1 AUTO BASS CHORD
- 2 DUAL
- 3 TOUCH
- 4 TEMPO
- 5 BEAT
- 6 VOLUEM
- 7 CHORD
- 8 STYLE/SONG/VOICE
- 9 STORE M1-M6
- 10 ONE TOUCH SETTING
- 11 CHORD DICTIONARY
- 12 LESSON 1
- 13 LESSON 2
- 14 LESSON 3
- 15 BASS CLEF
- 16 TREBLE CLEF
- 17 61 KEYBOARD

# Preparation

## Power Supply

This electronic keyboard can be powered by the current of a standard household wall outlet (using the specified AC adaptor) or by batteries.

### 1. Using The AC Adaptor

Make sure that only the AC adaptor specified for this electronic keyboard is used. The adaptor shall be 12V DC output, and center positive type. Be sure to turn off the electronic keyboard before you connect the adaptor into the AC wall outlet and the cord into the unit.

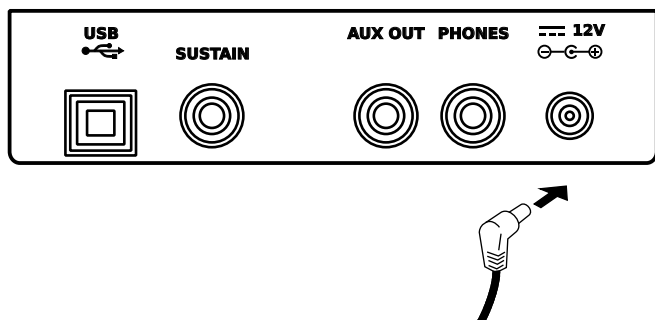

#### CAUTIONS!

- Use only the specified AC adaptor. Using other types of adaptor creates the risk of fire and electrical shock.
- For safety sake, be sure to unplug the AC adaptor from the wall outlet whenever leaving the electronic keyboard unattended for a long time.

### 2. Using Batteries

Always make sure to turn the keyboard off before inserting new batteries or replacing old ones.

#### ● To insert batteries

Open the battery compartment on the bottom of the keyboard.

Insert 6 D-size (SUM-1, R-20) batteries into the battery compartment and follow the correct polarity.

Replace the compartment cover and make sure that it locks firmly in place.

#### ● Low battery indications

Any of the following symptoms indicate low battery power. Replace the batteries as soon as possible whenever any of the following occurs.

A dim and difficult-to-read LCD display.

Abnormally low speaker/headphone volume.

Distortion of the sound output.

Sudden power failure when playing at high volume.

Abnormal rhythms or demo songs are played.

Dimming of the display when playing at high volume.

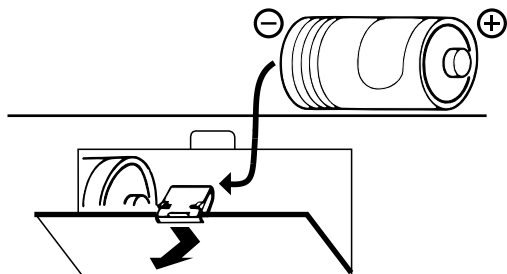

#### CAUTIONS!

- When inserting batteries, make sure to follow the polarity marking.
- Never use batteries of different types.
- Never mix old batteries with new ones.
- Replace the batteries as soon as possible after any sign of discharge.
- Always remove the batteries from the battery compartment when the keyboard is not expected to be used for a long period of time.

## Setting Music Stand

Please set up the music stand as the instruction below:

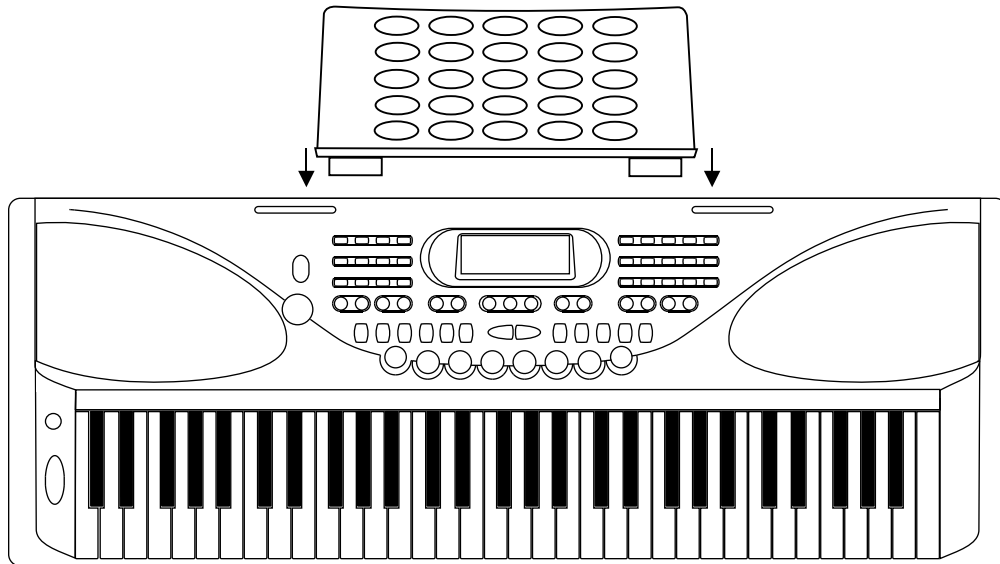

## Connections

### Headphone Jack

1. If you prefer to play with headphone for high quality personal monitoring, plug a set of stereo headphone into the rear panel PHONES jack.
2. Plug a set of headphone into the PHONES jack and the speakers will be shut automatically.

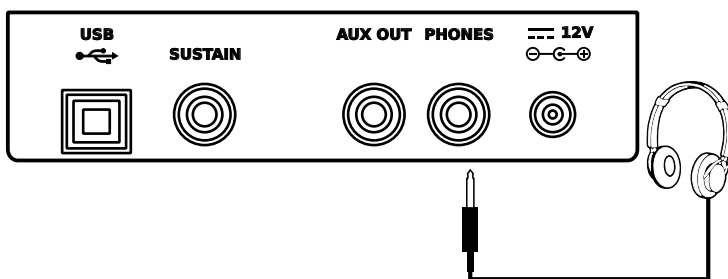

**NOTE:**

Never use headphones in high volume, as it may hurt your ears.

### AUX.OUT Jack

1. The AUX. OUT jack delivers the output signal of the keyboard to an external amplifier.
2. Use an audio cord to plug into the AUX. OUT jack located on the rear panel; then plug the other end of the cord into LINE IN or AUX. IN of the amplifier.

## Connections

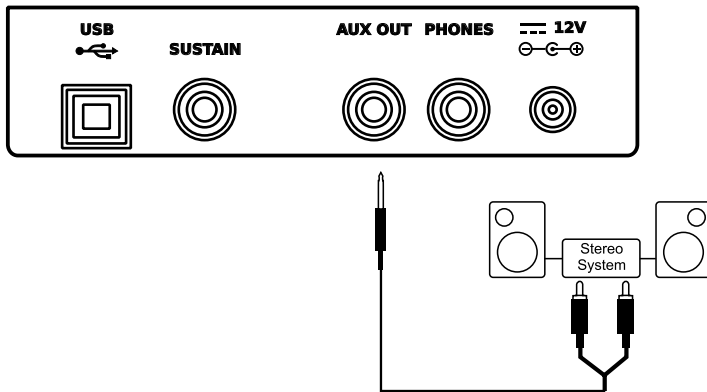

### NOTE:

To avoid damaging of the speakers, please ensure that the volume has set to the minimum level before connecting the power and other devices.

## Sustain Jack

1. An optional footswitch can be plugged into the SUSTAIN jack for sustain control.
2. The footswitch functions like the damper pedal of a piano. Press for sustain, release for normal sound.

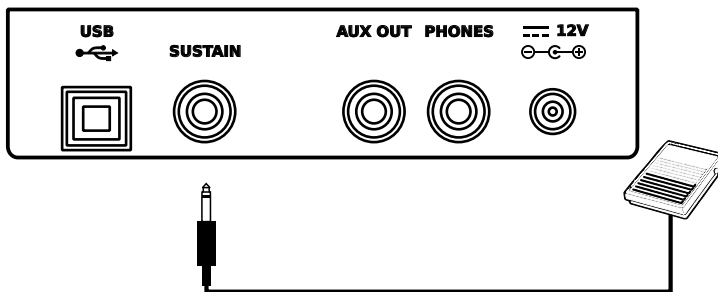

## USB Jack

1. Connect PC or other USB host devices that support USB Audio.
2. For devices with USB cable, after the driver is installed and initialization is finished, you can choose USB Audio Device in the device menu of the software to transfer midi data.

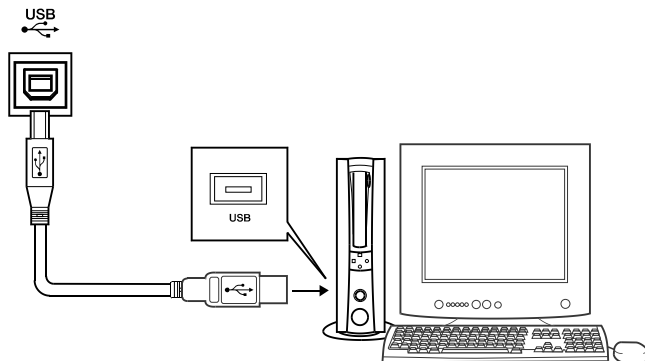

### ⚠ WARNING

To avoid damages, turn the power switches of this keyboard and all related devices OFF if you want to plug in or unplug between this instrument with all related devices.

# Basic Operation

## Power Switch & Volume

1. Turn the  $\nabla$ POWER $\blacktriangledown$  switch on. The LCD display lights up.

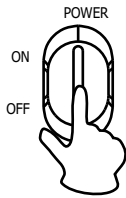

2. Use the  $\nabla$ VOLUME $\blacktriangledown$  control switch to adjust the volume to your desired level.

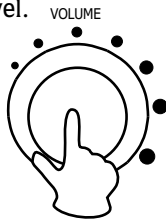

### NOTE:

- If the LCD display does not light up after you turned on the keyboard, please check the power supply.
- If the keyboard is silent, that means the volume has adjusted to its minimum level.

## Demo

There are total 50 demos. (See appendix)

1. Press  $\nabla$ DEMO $\blacktriangledown$  button to play demo songs.

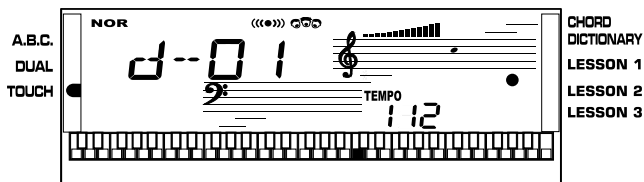

2. You can select a demo song with  $\nabla$  -  $\blacktriangledown$  /  $\nabla$  +  $\blacktriangledown$  button. The name of demo will appear on the LCD.

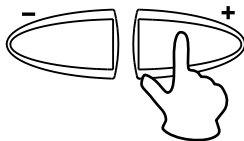

3. Press the  $\nabla$ DEMO $\blacktriangledown$  or  $\nabla$ START/STOP $\blacktriangledown$  button to exit from the demo mode.

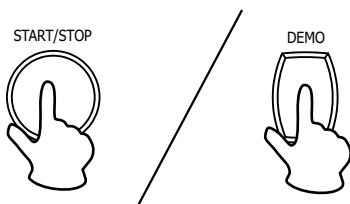

### NOTE:

In the demo mode, all function keys except DEMO, START/STOP, TEMPO, +/-, VOLUME, POWER ON/OFF will be voided.

# Voices and Effects

There are 138 voices in total (See appendix), including 128 GM voices, 8 Chinese voices, and 2 percussion voices.

## Select a Voice

1. Press  $\nabla$ VOICE $\blacktriangledown$  button to enter "voice mode". The default VOICE R1 is No:01; LCD displays "VOICE 1" and the voice number.

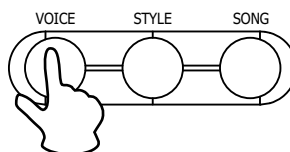
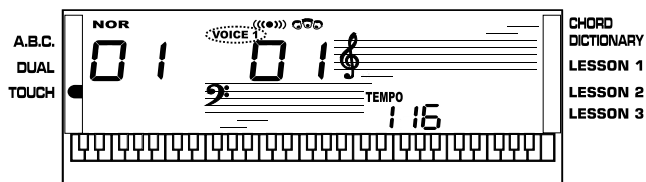

2. Press  $\nabla$ + $\blacktriangledown$ / $\nabla$ - $\blacktriangledown$  button or use the Direct Select Button to select the voice you want.

- Direct Select Button

Use the Direct Select Button to select a voice (among 30 voices), 2 direct voices for each button (upper & nether key)

3. After selecting a voice, you can now play the keyboard.



**NOTE:**

While changing a voice, pay attention to the rules:

If you press the same button, the voice will be changed between the upper and nether key.

When the upper/nether voice is on, and then you press another direct button, the corresponding upper/nether voice will be selected.

## Dual Voice

This keyboard has a "dual voice" function. This function is capable to enhance the delicacy of your music by playing two voices of musical instruments simultaneously; new combinations of voices and music could be created then. When the dual function is off, the voice indicated is VOICE 1, when the dual function is on, the voice indicated is VOICE 2.

1. During the VOICE 1 status, press [DUAL] button to enter the dual voice function. "VOICE R2" and "DUAL" signal would be lightened simultaneously. The number of the dual voice will be displayed on the LCD. Two selected voices will be overlapped at the same time.

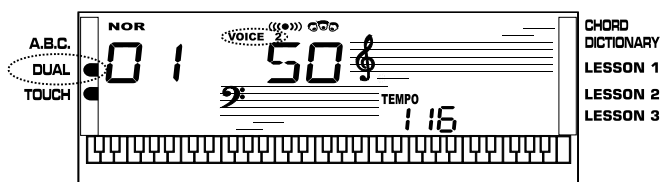

- To select your desired 'voice 2', press  $\nabla + \blacktriangledown / \blacktriangledown - \blacktriangledown$  button, or to select by the Direct Select Button.
- To experience the dual voice effect, play any note on the keyboard.

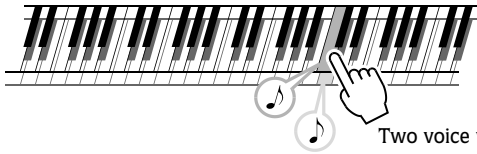

Two voice will sound at the same time.

**NOTE:**

In DUAL VOICE status, only the right section of keyboard has dual voice.

- Press  $\nabla$ DUAL $\blacktriangledown$  button again to turn off the dual voice function.

## Sustain

This function helps you to get a voice with a sustained effect, while playing the keyboard.

- Press  $\nabla$ SUSTAIN $\blacktriangledown$  button to activate the sustain effect. The "SUSTAIN flag" show up on the display.

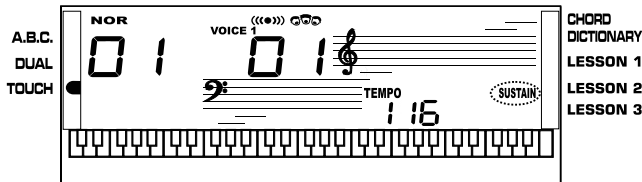

SUSTAIN



- Press  $\nabla$ SUSTAIN $\blacktriangledown$  button again to eliminate the sustain effect. The "SUSTAIN flag" will disappear.

**NOTE:**

When you step on the 'sustain pedal', its sustain effect is stronger than the effect by pressing the  $\nabla$ SUSTAIN $\blacktriangledown$  button.

## DSP Effect

This function allows you to perform the overall sound in a more realistic style.

- The DSP effect is set to ON when keyboard power on.

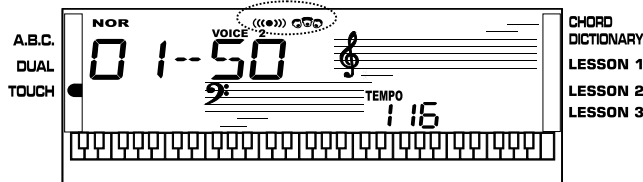

DSP



- Press  $\nabla$ DSP $\blacktriangledown$  button to turn off the DSP effect.

## Voices and Effects

### Pitch Bend

The pitch bend wheel can be used to bend the note upwards or downwards, range between +/- 2 cent. When the wheel is released, the note will return back to the normal status.

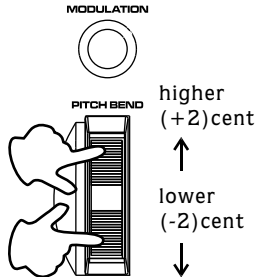

### Modulation

Press and hold  $\nabla$ MODULATION $\blacktriangledown$  button. You can hear the modulation effect while playing the keyboard. Release the button to exit the modulation effect.

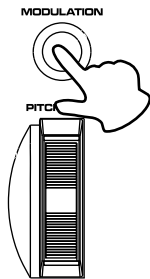

**NOTE:**

In MODULATION status, only the right section of the keyboard has the modulation effect.

### Touch

This function allows you to turn on the dynamic level while playing the keyboard.

1. The LCD will display the "touch value". If the "touch function" is disabled, there will be no touch response.

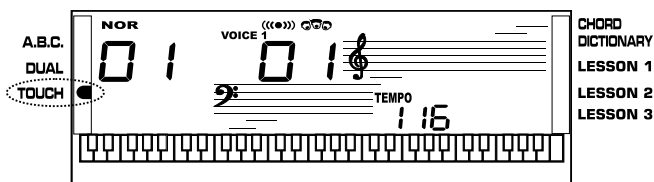

2. To experience the effect, play any note on the keyboard after you turn it on.

## Transpose

You can change the key of the entire keyboard with the **TRANPOSE** function by adjusting the pitch in semitone steps..

1. Press  $\nabla$ TRANPOSE + $\blacktriangledown$  or  $\nabla$ TRANPOSE - $\blacktriangledown$  button to the Transpose setting mode.  
The LCD will display the current transpose value. The default octave value is 00.  
Use  $\nabla$ TRANPOSE + $\blacktriangledown$ / $\nabla$ TRANPOSE - $\blacktriangledown$  to adjust the value from 12 to +12 semitones.

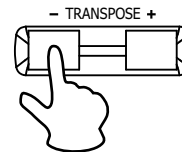
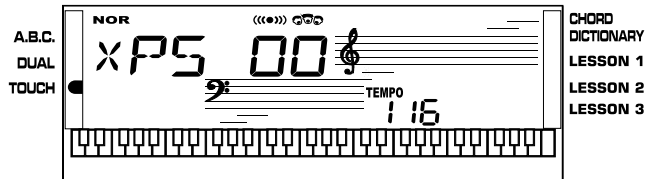

2. Press  $\nabla$ TRANPOSE + $\blacktriangledown$  and  $\nabla$ TRANPOSE - $\blacktriangledown$  simultaneously to set the default value: 00.

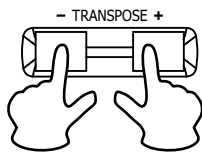

**NOTE:**

If you don't press any button for 5 seconds after entering the Transpose setting mode, it will quit this menu automatically.

## Octave

1. Press  $\nabla$ OCTAVE + $\blacktriangledown$  or  $\nabla$ OCTAVE - $\blacktriangledown$  button to set the Octave mode.  
The LCD will display the current octave value. Use  $\nabla$ OCTAVE + $\blacktriangledown$ / $\nabla$ OCTAVE - $\blacktriangledown$  to change the octave value.  
This function can change the key to 1 octave up or down.

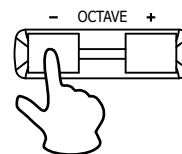
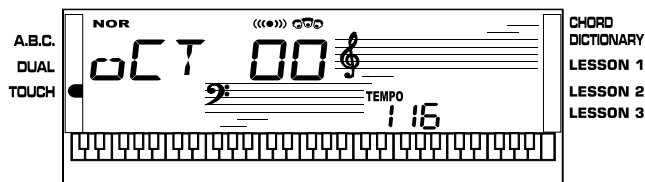

2. Press  $\nabla$ OCTAVE + $\blacktriangledown$  and  $\nabla$ OCTAVE - $\blacktriangledown$  simultaneously to set the tune value back to its default.

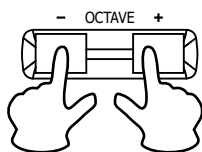

**NOTE:**

If you don't press any button for 5 seconds after entering the Octave setting mode, it will quit this menu automatically.

3. The default octave value is 00.

# Style Control

The keyboard has a total of 100 styles, from 1 to 100. The default style is 01.

## Select a Style

1. Press  $\nabla$ STYLE $\blacktriangledown$  button to set the keyboard to the "style mode". The "STYLE flag" and the style number will show up on the display.

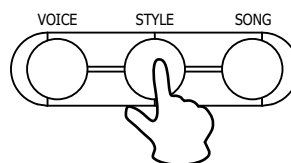
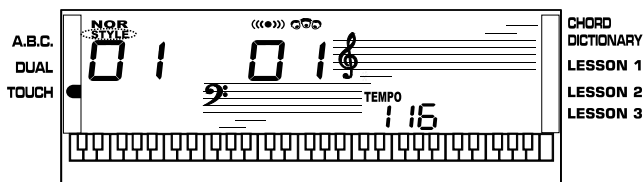

2. Press  $\nabla$ + $\blacktriangledown$ / $\nabla$ - $\blacktriangledown$  button or use the Direct Select Button to select the voice you want.

- Direct Select Button

Use the Direct Select Button to select your desired style (among 24 styles), 2 direct styles for each button (upper & nether).

3. After a style is selected, you can then play the keyboard.

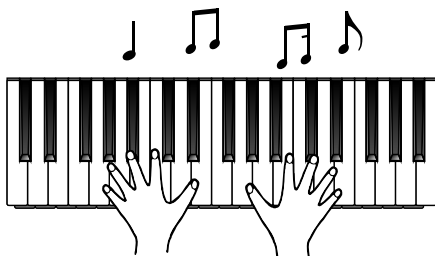

**NOTE:**

While changing a style, pay attention to the rules:  
If the same button has been pressed twice, the style will be swapped from one to another.

When the upper/nether style is on, and you then press another direct button, the corresponding upper/nether style will be selected.

## Start a Style

### 1. Start button:

Use  $\nabla$ START/STOP $\blacktriangledown$  button to start the style.

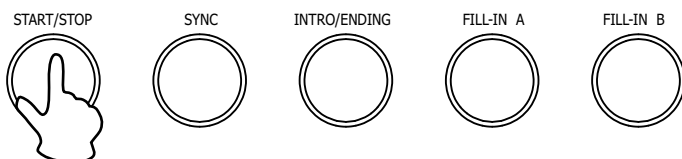

# Style Control

## 2. A.B.C. mode

Press  $\nabla$ A.B.C $\nabla$  button to set the A.B.C mode on. The A.B.C flag will appear on the LCD. Under this mode, the keys below the split point are known as the CHORD area.

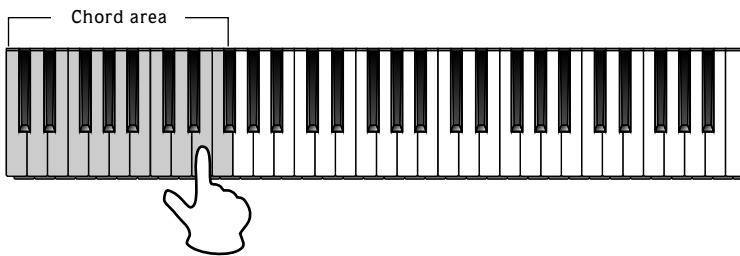
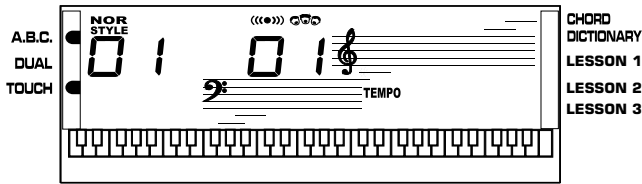

### NOTE:

There are 2 ways to detect the chord: "single finger detect" and "multi fingers detect". If a chord played has been detected in notes more than one, it is recognized as the "multi fingers chord". If not, "single finger chord" will be recognized.

## 3. Sync Start

Press  $\nabla$ SYNC $\nabla$  button. There will be 4 beats flashing simultaneously on the screen according to the current tempo.

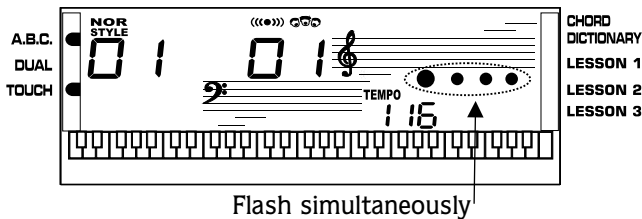

### NOTE:

If A.B.C. mode is off, play any key on the keyboard to start a style.

If A.B.C. mode is on, play only the chord area key to start a style with the Auto Bass Chord accompaniment.

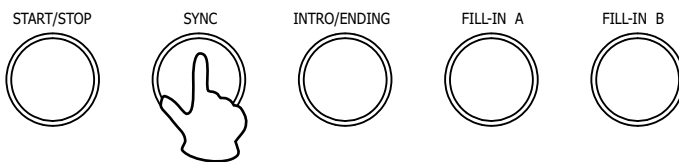

## 4. Intro Start

Press the  $\nabla$ INTRO/ENDING $\nabla$  button to insert an intro section before you start to play.

The intro section will be followed by the main section.

There are two main sections, "normal" and "variation". It has its own two or four-measure section.

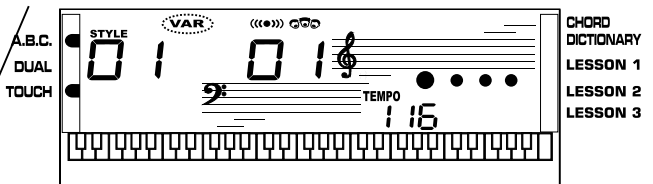
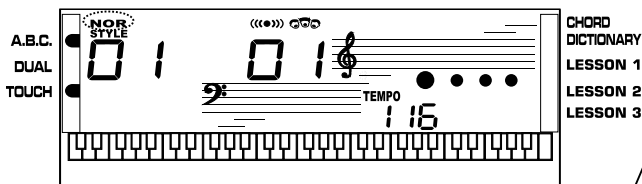

INTRO/ENDING



## Stop a Style

### 1. Stop immediately

Use  $\nabla$ START/STOP $\blacktriangledown$  button to start a style.

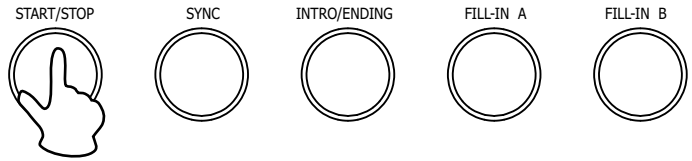

### 2. Ending stop

Press the  $\nabla$ INTRO/ENDING $\blacktriangledown$  button if you want to proceed to the ending section and then stop.

The ending section will begin from the top of the next measure.



### 3. Sync stop

Press the  $\nabla$ SYNC $\blacktriangledown$  button to stop playing, and the synchronized start mode will be activated.



## Intro/Ending

This function is applicable to add in the beginning / ending of a style. Its length varies in different styles.

- If you press the  $\nabla$ INTRO/ENDING $\blacktriangledown$  button before starting a style, this key will be used as the INTRO function.
- When the "INTRO/ENDING " mode is processing, "NOR " or "VAR " above the LCD will be flashing until the mode finishes.

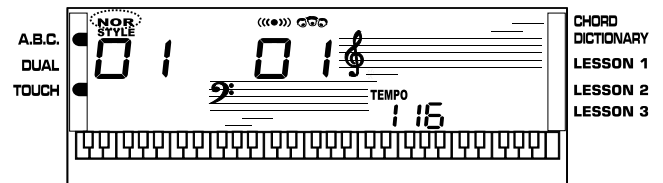

- Press  $\nabla$ START/STOP $\blacktriangledown$  or  $\nabla$ SYNC $\blacktriangledown$  and the style will begin with a fill in intro. When a style is playing, hit this key as an ENDING function.

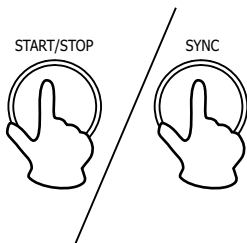

#### NOTE:

After you pressed FILL-IN A and then pressed the  $\nabla$ INTRO/ENDING $\blacktriangledown$  button, the NOR flag will be flashing.

After you pressed FILL-IN B and then pressed the  $\nabla$ INTRO/ENDING $\blacktriangledown$  button, the VAR flag will be flashing.

# Style Control

## Fill A/B

1. Choose the desired style and press the  $\nabla$ START/STOP $\blacktriangledown$  button.
2. Press the  $\nabla$ FILL-IN A $\blacktriangledown$  button, the fill a-a or fill b-a will begin immediately and smoothly lead into the "normal style". LCD will display "NOR".

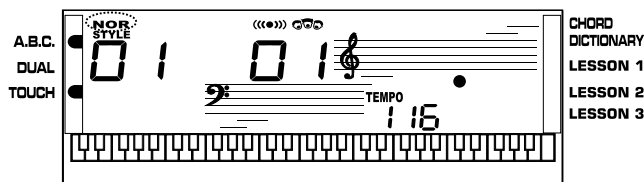
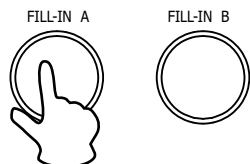

3. Press the  $\nabla$ FILL-IN B $\blacktriangledown$  button, the fill a-b or fill b-b will begin immediately and smoothly lead into the "variation style". LCD will display "VAR".

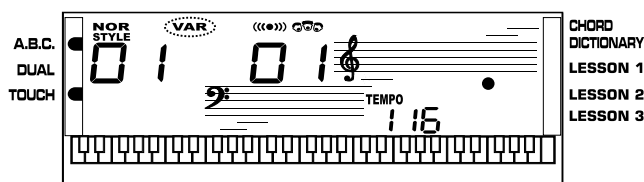
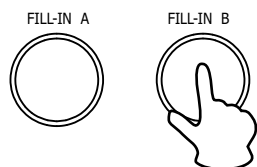

#### 4. Playing FILL IN A / FILL IN B section

- In NORMAL mode, press  $\nabla$ FILL-IN A $\blacktriangledown$  button to insert 1 measure fill in and LCD will flash out 'NOR'. After one measure is over, NORMAL style will be returned.
- In VARIATION mode, press  $\nabla$ FILL-IN B $\blacktriangledown$  button to insert 1 measure fill in and LCD will flash out 'VAR'. After one measure is over, VARIATION style will be returned.
- In NORMAL mode, press  $\nabla$ FILL-IN B $\blacktriangledown$  button to insert 1 measure fill in and LCD will flash out 'VAR'. After one measure is over, VARIATION style will be started.
- In VARIATION mode, press  $\nabla$ FILL-IN A $\blacktriangledown$  button to insert 1 measure fill in and LCD will flash out 'NOR'. After one measure is over, NORMAL style will be started.

#### NOTE:

Hold down the button when a style is playing, the FILL pattern repeats continually until you release the button.

Press  $\nabla$ FILL-IN A $\blacktriangledown$ , when the style stops, it will be changed to the "normal section", the 'NOR' flag on the LCD will be lightened.

Press  $\nabla$ FILL-IN B $\blacktriangledown$ , it will be changed to the "variation section", the 'VAR' flag on the LCD will be lightened.

## Tempo

1. Press the  $\nabla$ TEMPO+ $\blacktriangledown$  or  $\nabla$ TEMPO- $\blacktriangledown$  button to change the tempo.

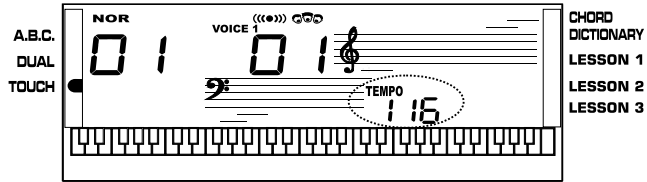
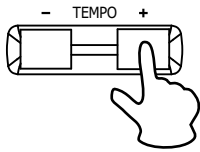

2. Press  $\nabla$ TEMPO+ $\blacktriangledown$  and  $\nabla$ TEMPO- $\blacktriangledown$  simultaneously to set the tempo value back to its default one.

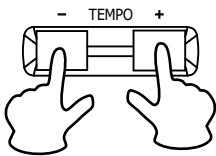

**NOTE:**

Selecting a style when it stops, the tempo will be change with the style automatically to the default one. When a style is playing, the tempo will not change along with the style.

## Accomp Volume

1. Press  $\nabla$ ACC.VOL+ $\blacktriangledown$  or  $\nabla$ ACC.VOL- $\blacktriangledown$  button to adjust the ACCOMP volume. The LCD displays the ACCOMP volume ranges between 0 and 31.(Default ACCOMP value is 26.)

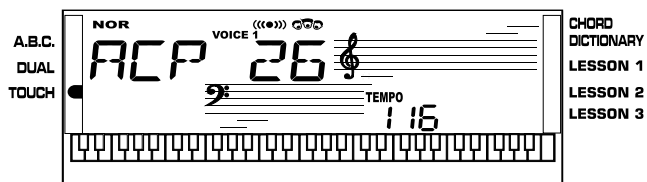
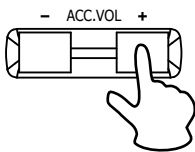

2. Press  $\nabla$ ACC.VOL+ $\blacktriangledown$  and  $\nabla$ ACC.VOL- $\blacktriangledown$  buttons together to turn off the ACCOMP volume.

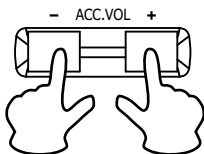

3. Press  $\nabla$ ACC.VOL+ $\blacktriangledown$  and  $\nabla$ ACC.VOL- $\blacktriangledown$  buttons together again to turn on the ACCOMP volume.

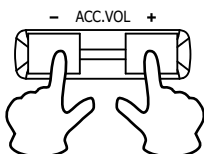

## Chord Recognize

"A.B.C." is off on the keyboard is the default mode. Press  $\nabla$ A.B.C. $\blacktriangledown$  button to turn on this "auto bass chord" function, the A.B.C. flag on the LCD is lightened. The left section of the keyboard is known as the "chord area", while playing the chord, both the bass and the chord voices phonate.

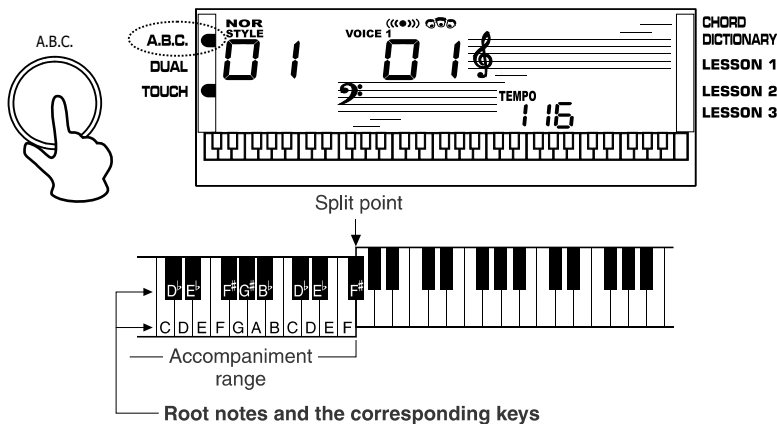

CHORD  
DICTIONARY  
LESSON 1  
LESSON 2  
LESSON 3

### NOTE:

Since the chord detection of A.B.C. is based on the Chord Root priority, some chords that could be played under the Chord Dictionary may not be recognised by A.B.C. , eg. B6 } bB6 } B6(9) } bB6 } 9 } Baug } bBaug } bBm6 } Bm6 } Adim7 } bBdim7 } Bdim.

### There are 2 ways to detect the chord: "single finger detect" and "multi fingers detect".

If the chord played is based on "multi fingers detect", it is recognized as the "multi fingers chord". If not, "single finger chord" will be recognized.

#### • Single Finger Chords

This method allows you easily play chords easily in the accompaniment range of the keyboard using only one, two, or three fingers.

The examples of Single Finger Chord "C, Cm, C7 and Cm7" are shown as below:

	<p><b>C</b></p> <p>• To play a major chord Press the root note of the chord</p>
	<p><b>Cm</b></p> <p>• To play a minor chord Press the root note together with the nearest black key to the left of it .</p>
	<p><b>C7</b></p> <p>• To play a seventh chord Press the root note together with the nearest white key to the left of it .</p>
	<p><b>Cm7</b></p> <p>• To play a minor seventh chord Press the root notes together with the nearest white and black keys to the left of it (three keys altogether) .</p>

### NOTE:

When A.B.C. is on, press the keys on the left of split point. The chord will be recognized as single finger chords.

#### • Multi Finger Chords

This method allows you to produce an accompaniment by playing chords with normal fingerings in the accompaniment range of the keyboard.

To play Multi Chords ( Example for C chords)  
A total of 32 chords are provided as below:

0 C	1 C <sub>6</sub>	2 C <sub>M7</sub>	3 C <sub>M7</sub> (#11)	4 C <sub>M</sub> (9)	5 C <sub>M7</sub> ( <sup>9</sup> )
6 C <sub>6</sub> ( <sup>9</sup> )	7 C <sub>aug</sub>	8 C <sub>m</sub>	9 C <sub>m6</sub>	10 C <sub>m7</sub>	11 C <sub>m7</sub> (b5)
12 C <sub>m</sub> ( <sup>9</sup> )	13 C <sub>m7</sub> ( <sup>9</sup> )	14 C <sub>m7</sub> ( <sup>11</sup> )	15 C <sub>m</sub> M <sub>7</sub>	16 C <sub>m</sub> M <sub>7</sub> ( <sup>9</sup> )	17 C <sub>dim</sub>
18 C <sub>dim7</sub>	19 C <sub>7</sub>	20 C <sub>7sus4</sub>	21 C <sub>7</sub> (b5)	22 C <sub>7</sub> ( <sup>9</sup> )	23 C <sub>7</sub> (#11)
24 C <sub>7</sub> (b13)	25 C <sub>7</sub> (b9)	26 C <sub>7</sub> (13)	27 C <sub>7</sub> (#9)	28 C <sub>M7aug</sub>	29 C <sub>7aug</sub>
30 C <sub>sus4</sub>	31 C <sub>1+2+5</sub>	Notes enclosed in parentheses ● are optional; the chords could be recognized without them.			

## • Chord Basics

**Three or more notes played together constitute a "chord".**

The most basic chord type is the "triad" consisting three notes: the root, third, and fifth degrees of the corresponding scale.

A "C major triad", for example, is made up of the notes C (the root), E (the third note of the C major scale), and G (the fifth note of the C major scale).

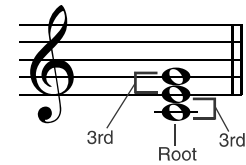

In the C major triad shown above, the lowest note is the "root" of the chord (this is the chord's "root position"...using other chord notes for the lowest note results in "inversion"). The root is the central sound of the chord, which supports and anchors the other chord notes.

The distance (interval) between adjacent notes of triad in root position is either a major or minor third.

Major third – four half steps (semitones)

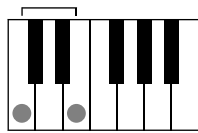

Minor third – three half steps (semitones)

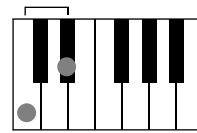

The lowest interval in our root-position triad (between the root and the third) determines whether the triad is a major or minor chord, and we can shift the highest note up or down by a semitone to produce two additional chords, as shown below.

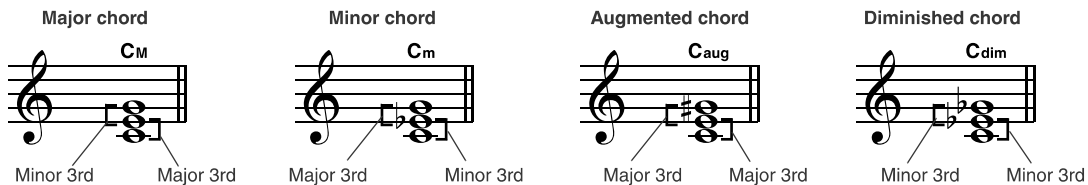

The basic characteristics of the chord sound remain intact even if we change the order of the notes to create different inversions. Successive chords in a chord progression can be smoothly connected, for example, by choosing the appropriate inversions (or chord "voicings").

## • Reading Chord Names

Chord names tell you just about everything you need to know about a chord (other than the inversion/voicing). The chord name tells you what the root of a chord is, whether it is major, minor, or diminished, whether it requires a major or flatted seventh, what alterations or tension does it use...all at a glance.

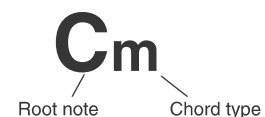

## • Some Chord Types

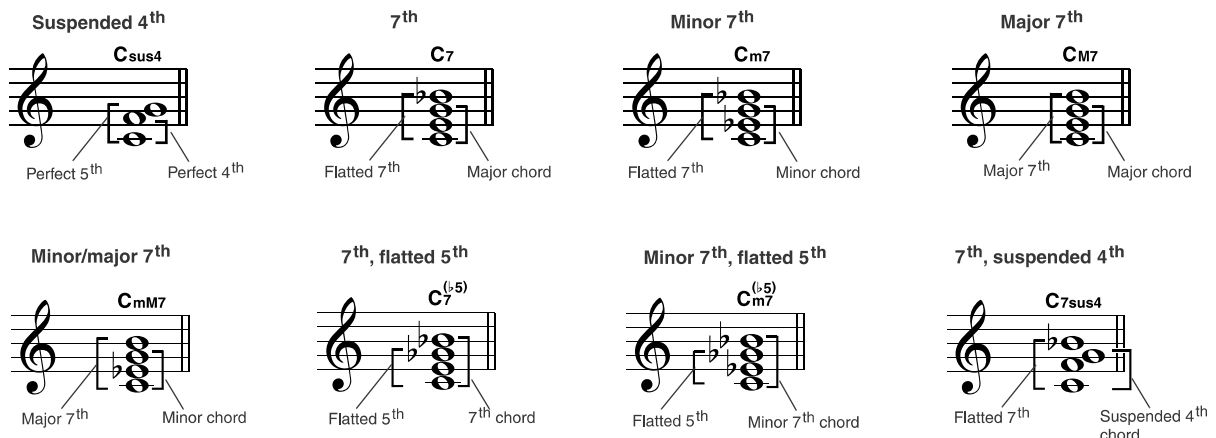

# Memory

Memory feature can be used to memorize 24 complete control-panel setups(4 banks, 6 setups each) that you can recall whenever needed.

## Memory bank

There are 4 banks at all, each bank has 6 memories (M1-M6).

1. Press and hold  $\nabla$ STORE $\blacktriangledown$ , press  $\nabla$ M1 $\blacktriangledown$ (or  $\nabla$ M2 $\blacktriangledown$ - $\nabla$ M4 $\blacktriangledown$ ) meanwhile. The data will be stored to the M1 (M2-M6),LCD displays the memory number MEM 1.

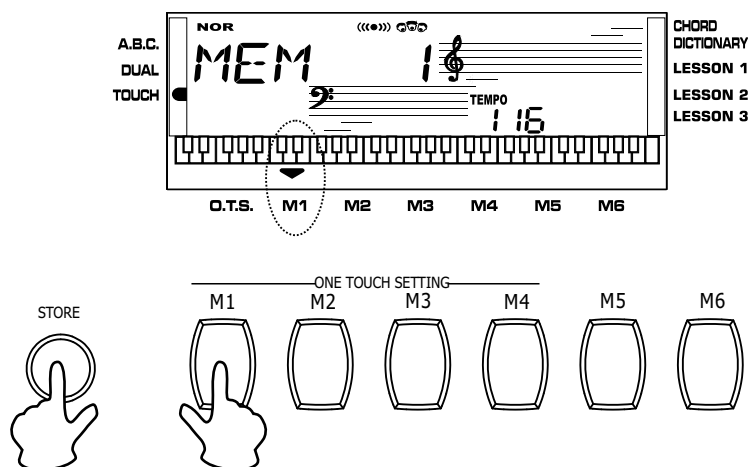

2. Press any of the  $\nabla$ M1 $\blacktriangledown$ - $\nabla$ M6 $\blacktriangledown$  button. LCD will display MEM 1- MEM 6.  
Use  $\nabla$ + $\blacktriangledown$  /  $\nabla$ - $\blacktriangledown$  button to select the bank you want.

### NOTE:

If the current data is not the same as the current memory data, the corresponding memory flag on the LCD will flash.

3. Press  $\nabla$ STORE $\blacktriangledown$  and  $\nabla$ M1 $\blacktriangledown$  simultaneously, the memory data will return to the default value.  
Please note that it will clear the record data.

## Memory Date

### 1. VOICE DATA

VOICE:VOICE R1, VOICE R2, and VOICE LOWER;

VOICE EFFECT:TOUCH NUMBER, DSP ON/OFF, SUSTAIN, ON/OFF, TRANSPOSE VALUE, TUNE, OCTAVE.

### 2. ACCOMP DATA

STYLE NUMBER, TEMPO, BEAT, A.B.C ON/OFF, ACCOMP VOLUME, NORMAL/VARIATION STATUS.

### 3. MIXER VOLUME

VOICE R1 VOLUME, VOICE R2 VOLUME, VOICE LOWER VOLUME, DRUM VOICE, BASS VOLUME, OC1, OC2, OC3 VOLUME.

# One Touch Setting

**One Touch Setting is a powerful and convenient function that allows you to reconfigure all settings instantly with the touch of a single button.**

**In this function, 4 types of parameters (M1~M4) will be loaded for operating the current style.**

1. Press  $\nabla$ O.T.S $\blacktriangledown$  button to turn this mode on and lighten the O.T.S. flag on the LCD. Press any of the  $\nabla$ M1 $\blacktriangledown$  ~  $\nabla$ M4 $\blacktriangledown$  button, it will load the relative type of parameter according to the current style. M1 and M2 store the parameters for the normal style, while M3 and M4 store the parameters for the "variation style". The keyboard will turn the A.B.C. mode on automatically while the O.T.S. is on.

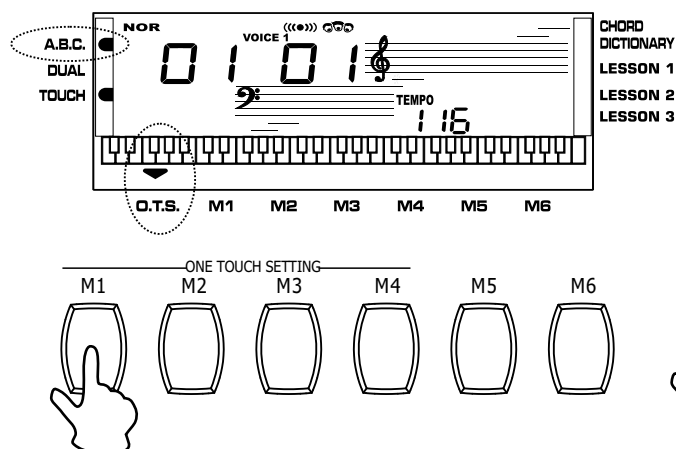

2. Press any of the M1-M4 buttons, which is corresponded to your desired setting.

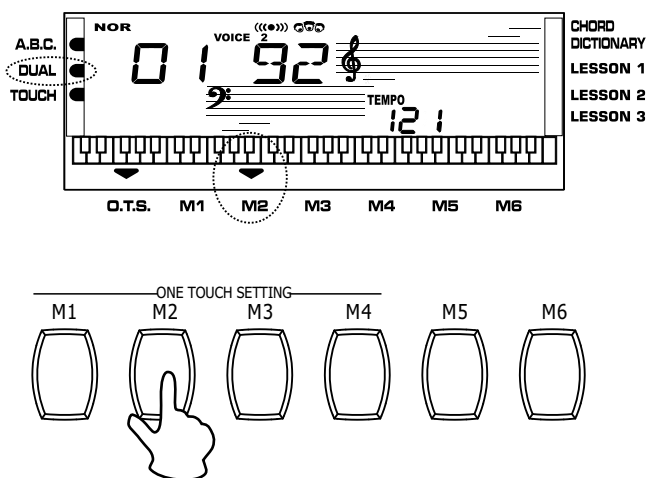

3. When a style is playing, press  $\nabla$ O.T.S $\blacktriangledown$  to turn the O.T.S. mode on; it will insert a "Fill in " section automatically. Insert "FILL-IN A" when  $\nabla$ M1 $\blacktriangledown$  or  $\nabla$ M2 $\blacktriangledown$  button is pressed. Insert "FILL-IN B" when  $\nabla$ M3 $\blacktriangledown$  or  $\nabla$ M4 $\blacktriangledown$  button is pressed.

4. Press  $\nabla$ O.T.S $\blacktriangledown$  button again to turn off the O.T.S. Mode.

5. The parameters stored in the O.T.S. including:  
VOICE R1, VOICE R2, OCTAVE(R1/R2) and VOLUME.

## NOTE:

While you are recording or playing back a recorded song, press any of the  $\nabla$ M1 $\blacktriangledown$  ~  $\nabla$ M4 $\blacktriangledown$  button, no "FILL IN" will be inserted.

# Record

## Start Record

1. Press the  $\nabla$ RECORD $\blacktriangledown$  button, the four-beat on the LCD will flash simultaneity, indicating a "record waiting status". A voice, style and memory can be selected in this status. The ACCOMP track and MELODY track can be recorded together.

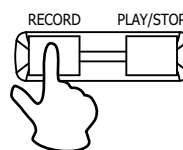
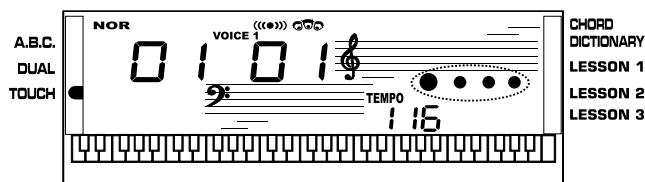

2. After all the settings in the "record waiting status" have been selected, next, play the keyboard (the chord area when recording ACCOMP) or press the  $\nabla$ START/STOP $\blacktriangledown$  button; it will start recording and the beat will display according to the current tempo.

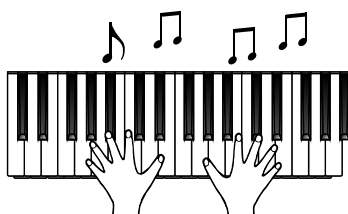

### NOTE:

Once the recording of one track is started, the original data in the track will be overwritten.

## Stop Record

### 1. STOP AUTOMATICALLY

While recording, once the capability is full, the recording will be stopped automatically, and will display "FULL" on the LCD. When a style is playing, press the  $\nabla$ INTRO/ENDING $\blacktriangledown$  button, it will stop recording automatically after "ending".

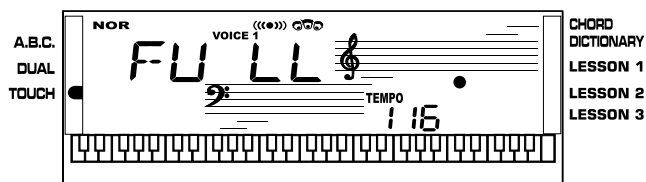

### 2. STOP MANUALLY

Press  $\nabla$ RECORD $\blacktriangledown$  button again while recording to stop this action immediately.

## Playback Record

Press  $\nabla$ PLAY/STOP $\blacktriangledown$  button to start playing the recorded data. Press  $\nabla$ PLAY/STOP $\blacktriangledown$  again to stop playing. Voice, style, memory and recording tracks can be selected in this status.

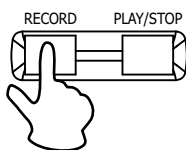

### NOTE:

If the recording memory is empty, the character "EMPTY" will appear temporary on the LCD, when you press  $\nabla$ PLAY/STOP $\blacktriangledown$ .

# Song

There are 50 songs in total (see Appendix). Each song can be practised in the LESSON mode.

## 1. START/STOP the song

Press  $\nabla$ SONG $\blacktriangledown$  button to enter the "song mode", the song flag on the LCD will show up. Then press  $\nabla$ START/STOP $\blacktriangledown$  or  $\nabla$ SONG $\blacktriangledown$  button, it will play the current song repeatedly. Press  $\nabla$ START/STOP $\blacktriangledown$  or  $\nabla$ SONG $\blacktriangledown$  button again to stop playing the song, but it will not quit the song mode.

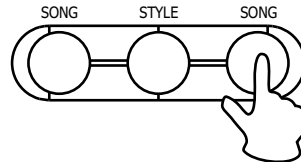
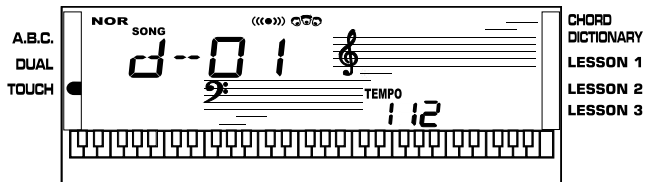

## 2. SELECT the song

Use  $\nabla$ + $\blacktriangledown$ / $\blacktriangledown$ - $\blacktriangledown$  button to select the song that you want.

3. Press  $\nabla$ LESSON $\blacktriangledown$  button to enter the "lesson mode". There are 3 different ways to practise the songs.

4. When the song is stopped, press  $\nabla$ CHORD DICTIONARY $\blacktriangledown$ ,  $\nabla$ STYLE $\blacktriangledown$ ,  $\nabla$ VOICE $\blacktriangledown$ ,  $\nabla$ DUAL $\blacktriangledown$  or voice/style Direct Select Button to exit the song mode.

# Lesson

In "song mode", press the  $\nabla$ LESSON $\blacktriangledown$  button to enter the lesson mode. The song mode includes LESSON 1/2/3.

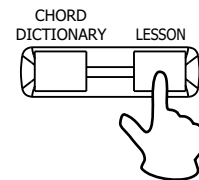
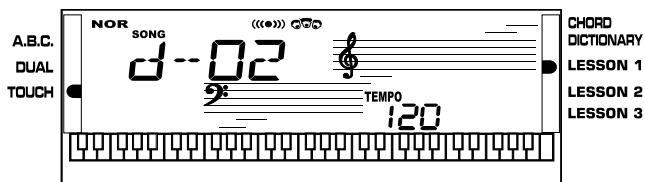

The 3 levels of the lessons are as follows:

## 1. LESSON 1

- Press  $\nabla$ LESSON $\blacktriangledown$  button to enter the lesson 1 mode, the lesson 1 flag will be lightened on the LCD.

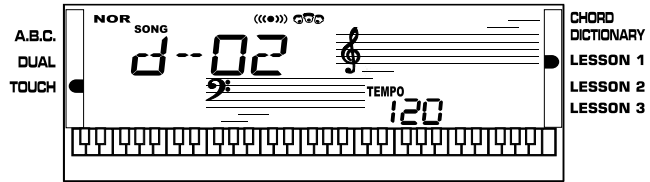
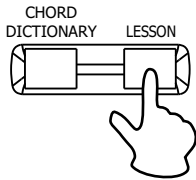

- Press the  $\nabla$ START/STOP $\blacktriangledown$  button, and then play the keyboard to start the LESSON.

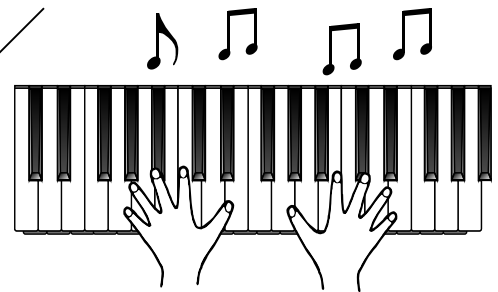
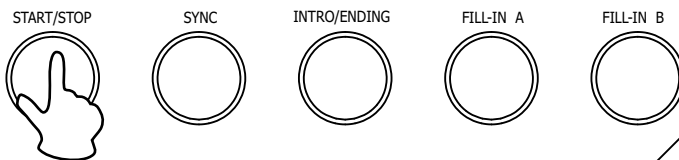

- This mode focuses on time practising, instead of notes accuracy.

## 2. LESSON 2

- Press the  $\nabla$ LESSON $\blacktriangledown$  button again to enter the lesson 2 mode, the lesson 2 flag will be lightened on the LCD.

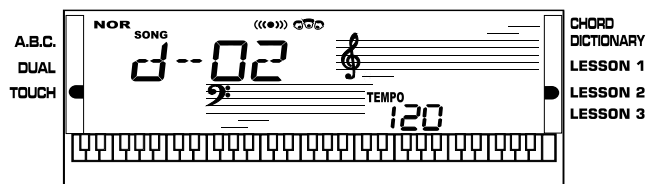
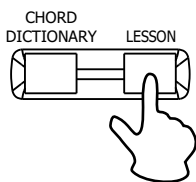

- Press the  $\nabla$ START/STOP $\blacktriangledown$  button and start playing the keyboard with the "LESSON" function.

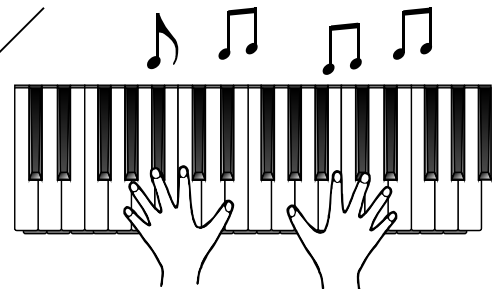
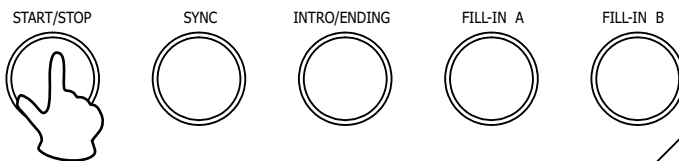

- This mode focuses on notes practising, instead of time accuracy.
- Once you have played the correct note, the song will continue to play to the next note.

### 3. LESSON 3

- Press the ▽LESSON▼ button during LESSON 2 mode for entering LESSON 3. Lesson 3 flag will be lightened on the LCD.

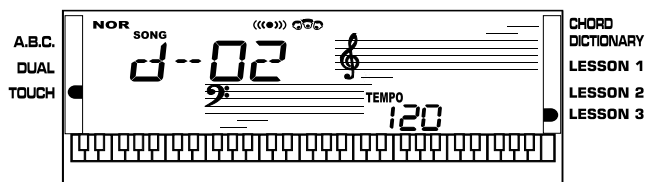
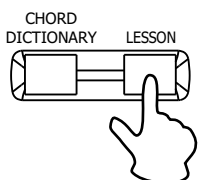

- Press the ▽START/STOP▼ button and start playing the keyboard with the "LESSON" function.

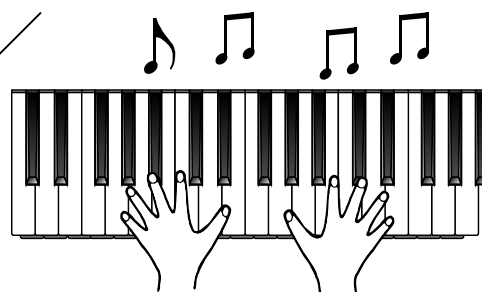
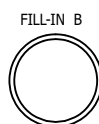
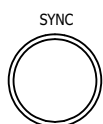

- This mode simply allows users to practise with time and notes, instead of their accuracy.
- Press the ▽START/STOP▼ button again to stop the LESSON mode.

# Chord Dictionary

Chord dictionary is a function which helps you to check for the chord notes.

1. Press  $\nabla$ CHORD DICTIONARY $\blacktriangledown$  button to enter the DICT mode. The "chord dictionary flag" on the LCD will be lightened. In this mode, the keys above "C4" are used to assign as the Chord Type, the keys above C6 are used to assign as the Chord Root.

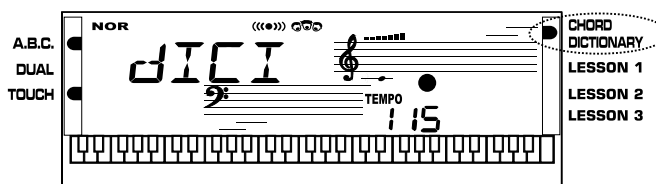
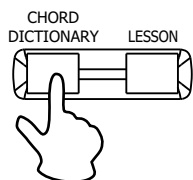

2. For example, if we want to play a Cm7 CHORD. Press the "C" key in the section of the keyboard labeled "CHORD ROOT". (The note does not sound) The root note you set will be shown on the display.

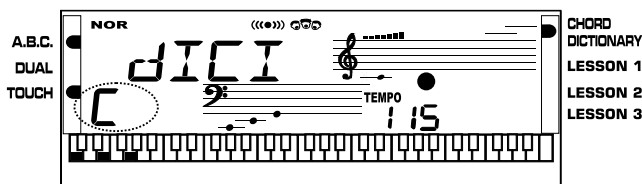
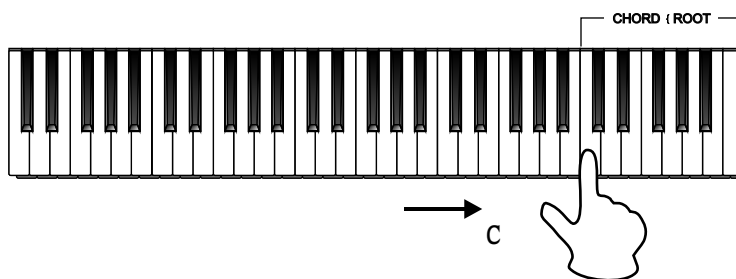

3. Press the "m7" key in the section of the keyboard which has labeled "CHORD TYPE" (The note does not sound). The notes you should play for the specified chord (root note and chord type) are shown in the display as the notation and also in the keyboard diagram.

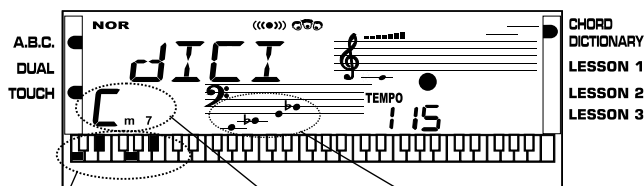
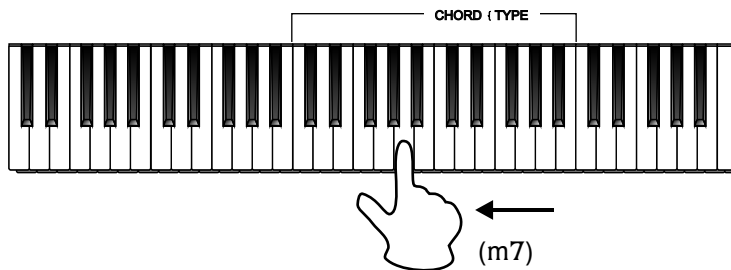

Individual notes of chord (keyboard)      Chord name (root and type)      Notation of chord

4. When the Chord Type and Chord Root are confirmed, the LCD will display the chord and its keyboard position. A bell sound will be heard when you play it correctly.

5. Specify and play the chord type and the chord root that you would like to play on the keyboard as follow:

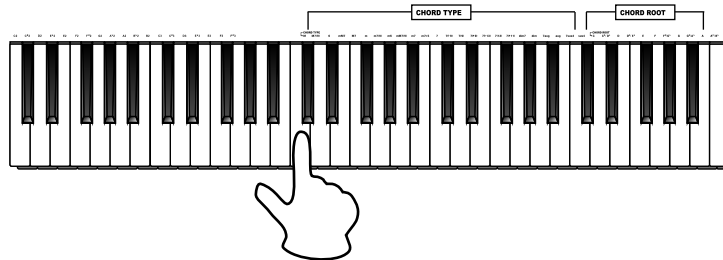

6. 24 chords will be displayed in the dictionary mode as follows:

**Chord Root :**

Note	Chord Root	Note	Chord Type
C6	C	F6#	F#/Gb
C6#	C#Db	G6	G
D6	D	A6b	Ab/G#
E6b	Eb/D#	A6	A
E6	E	B6b	Bb/A#
F6	F	B6	B

**Chord Type:**

Note	Chord type	Note	Chord type
C4	M	C5	7(b9)
C4#	M(9)	C5#	7(9)
D4	6	D5	7(#9)
E4b	mM7	E5b	7(b13)
E4	M7	E5	7(13)
F4	m	F5	7(#11)
F4#	m(9)	F5#	dim7
G4	m6	G5	dim
Ab4	m7(9)	A5b	7aug
A4	m7	A5	aug
B4b	m7b5	B5b	7sus4
B4	7	B5	sus4

7. Press  $\nabla$ CHORD DICTIONARY $\blacktriangledown$  button again to turn off the Chord Dictionary.

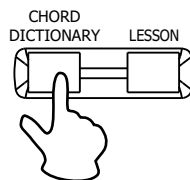

8. Some fingerings may be recognised as different chords by A.B.C. , eg. B6 } bB6 } B6(9) } bB6 7 9 5 } Baug } bBaug } bBm6 } Bm6 } Adim7 } bBdim7 } Bdim.

# MIDI Function

## What is MIDI

1. MIDI stands for "Musical Instrument Digital Interface", that is the standard interface between a PC and other electronic instrument(s).
2. USB connection can be used for midi data transference with computer or other USB host devices that support USB audio device with an USB cable.
3. The keyboard can be connected to the PC or other USB host device with an USB interface.
4. Use the keyboard as a tone generator, the data (MIDI) recorded on the PC or other USB host devices can be played on the keyboard.

### NOTE:

While a recording is playing back and a style is playing, you can not use the MIDI IN function, or the song you are playing will have error occurs for the same channel.

## USB Connection

### 1. System Requirements

- CPU: 300 MHz or higher, Pentium 2
- Memory: 64MB or more
- Hard Disk: at least 2 MB of free base
- OS: WINDOWS 2000/XP

### 2. The Method of Connection

Connect a standard USB cable between the rear-panel of the USB jack of the instrument and the USB jack on your computer (USB cable sold separately).

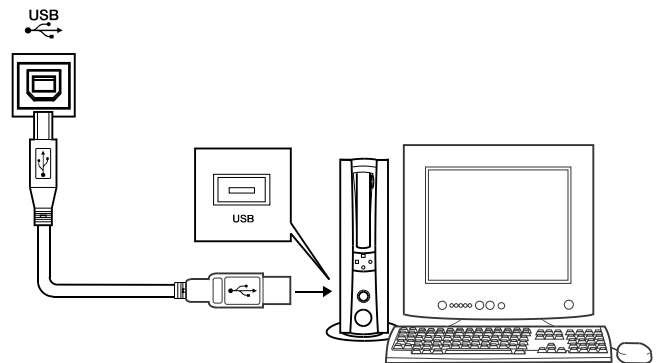

### 3. USB Precautions

Please observe the following precautions when connecting the instrument to a computer via a USB cable. Failure to do so can cause the instrument and/or the computer to hang up (freeze), possibly causing corruption or losing the data.

If the instrument or computer does hang up, turn the power of both devices off and then turn it on again after a few seconds.

### CAUTIONS!

Activate the computer from a sleep/suspended/standby mode before connecting the USB cable.

Connect the USB cable to the instrument and a computer before turning the power of the instrument on.

### MIDI Application

1. The keyboard can control other equipments or electronic instruments.
2. Some equipments can be used to control the keyboard.
3. PC recorded data (MIDI) can be played on the keyboard.
4. In order to transfer songs between your computer and the keyboard you will need to install other applications.

# Specifications

LCD display	Multi-functional LCD
Keys	61 keys with Touch Response
Polyphony	64-note polyphony(max)
Voice	138 Voices
Style	100 Styles
Demo Song	50 Demo songs
Control button	Power on/off, Volume, Accomp Volume, Tempo +/-, Chord Dictionary Lesson, Voice, Style, Song, O.TS. , M1-M6, Store, Start/Stop, Sync, Intro/Ending, Fill-in A, Fill-in B, A.B.C. Record, Play/Stop, Dual, Touch, Sustain, DSP, Demo, Transpose +/- , Octave +/-, +/-
Accompaniment Control	Start/Stop, Sync, Intro/Ending, Fill-in A, Fill-in B
Record Function	Record, Play/Stop
Panel Memory	24 Memory Storage
Power Supply	≡ 12V 2000mA
Connectors	AC Power, Headphones, Aux.Out, Sustain, USB
Speaker	4次 10w x 2
Dimension	970(L)x350(W)x135(H)mm
Weight	5kg(without batteries)
Attachment	Adaptor, Music stand, manual

\* All specifications and appearances are subject to change without notice.

# Trouble Shooting

Problem	Possible Cause and Solution
No matter the instrument is turned on or off, a popping sound will be temporarily produced.	This is normal and indicates that the instrument is receiving electrical power.
There is no sound even when the keyboard is played or when a song or style is being played.	Check if any cable or headphone is connected to the PHONES jack on the rear panel. When a set of headphones is plugged into this jack, no sound is output.
The volume is too soft. The sound quality is poor. The rhythm stops unexpectedly or not responding. The recorded data of the song is not playing correctly. The LCD display suddenly goes dark, and all panel settings are reset.	The batteries are low or dead. Replace all six batteries with completely new ones, or use the optional AC adaptor.

# Appendix 1 - Voice List

NO	Name
<b>PIANO</b>	
01	Grand Piano
02	Bright Piano
03	El Grd Piano
04	Honky-Tonk Piano
05	Elec Piano 1
06	Elec Piano 2
07	Harpsichord
08	Clavi
<b>MALLET</b>	
09	Celesta
10	Glockenspiel
11	Music Box
12	Vibraphone
13	Marimba
14	Xylophone
15	Tubular Bell
16	Dulcimer
<b>ORGAN</b>	
17	Drawbar Organ
18	Percussive Organ
19	Rock Organ
20	Church Organ
21	Reed Organ
22	Accordion
23	Harmonica
24	Tango Accordion
<b>GUITAR</b>	
25	Nylon Guitar
26	Steel Guitar
27	Jazz Guitar
28	Clean Guitar
29	Muted Guitar
30	Overdriven Guitar
31	Distortion Guitar
32	Guitar Harmonics
<b>BASS</b>	
33	Acoustic Bass
34	Finger Bass
35	Picked Bass
36	Fretless Bass
37	Slap Bass 1
38	Slap Bass 2
39	Synth Bass 1
40	Synth Bass 2
<b>STRINGS</b>	
41	Violin
42	Viola
43	Cello
44	Contrabass

45	Tremolo Strings
46	Pizzcato Strings
47	Harp
48	Timpani
<b>STRING ENSEMBLE</b>	
49	Strings 1
50	Strings 2
51	Synth Strings 1
52	Synth Strings 2
53	Choir Aahs
54	Voice Ooh
55	Synth Voice
56	Orchestra Hit
<b>BRASS</b>	
57	Trumpet
58	Trombone
59	Tuba
60	Muted Trumpet
61	Horn
6 2	Brass Ensemble
63	Synth Brass 1
64	Synth Brass 2
<b>REED</b>	
65	Soprano Sax
66	Alto Sax
67	Tenor Sax
68	Baritone Sax
69	Oboe
70	English Horn
71	Bassoon
72	Clarinete
<b>PIPE</b>	
73	Piccolo
74	Flute
75	Recorder
76	Pan Flute
77	Blown Bottle
78	Shakuhachi
79	Whistle
80	Ocarina
<b>LEAD</b>	
81	Square
82	Sawtooth
83	Calliope
84	Chiff
85	Charang
86	Voice
87	Fifths
88	Bass Lead
<b>PAD</b>	
89	Fantasia
90	Warm

91	Poly Synth
92	Cho ir
93	Bowed
94	Metallic
95	Halo
96	Sweep
<b>EFFECTS</b>	
97	Rain
98	SoundTrk
99	Crystal
100	Atmosphr
101	Bright
102	Goblins
103	Echoes
104	Sci-Fi
<b>ETHNIC</b>	
105	Sitar
106	Banjo
107	Shamisen
108	Koto
109	Kalimba
110	Bag Pipe
111	Fiddle
112	Shanai
<b>PERCUSSIVE</b>	
113	Tinkle Bell
114	Agogo
115	Steel Drums
116	Woodblock
117	Taiko Drum
118	Melodic Tom
119	Synth Drum
120	Reverse Cymbal
<b>SOUND EFFECTS</b>	
121	Gt Fret Noise
122	Breath Noise
123	Seashore
124	Bird Tweet
125	Telephone Ring
126	Helicopter
127	Applause
128	Gunshot
<b>CHINESE INSTRUMENT</b>	
129	Pipa
130	Guzheng
131	Yangqin
132	Erhu
133	Hi-sola
134	Lushen
135	Qudi
136	Xiao
<b>DRUM SET</b>	
137	Standard drum
138	ChinesePercussion

# Appendix 2- Style List

<b>8/16BEAT</b>	
01	8 Beat 1
02	8 Beat 2
03	8 Beat 3
04	8 Beat 4
05	8 Beat 5
06	8 Beat Rock
07	8 Beat Pop
08	16 Beat 1
09	16 Beat 2
10	Hiphop
11	16 Beat Funk
12	Funk Pop
13	Fusion
14	Jazz Rock
15	Shuffle
<b>BALLAD</b>	
16	Slow Ballad
17	Ballad 1
18	16 Beat Ballad
19	Pop Ballad
20	Dance Ballad
21	Organ Ballad
22	Blues Ballad
<b>ROCK</b>	
23	Hard Rock
24	Slow Rock 1
25	Rock
26	Rock & N*Roll
27	6/8 Rock
28	Rock Shuffle
29	4/4 Blues
<b>DANCE</b>	
30	Disco 1
31	Disco 2
32	Dance
33	House
34	Techno
<b>SWING&amp;JAZZ</b>	
35	Big Band Boogie
36	Jazz Ballad
37	Big Band Ballad
38	Boogie

39	Swing 1
40	Swing 2
41	Dixieland
42	Jazz Trio
<b>R &amp; B</b>	
43	R&B 1
44	R&B 2
45	Soul
46	Soul Shuffle
<b>COUNTRY</b>	
47	Country Pop
48	Country
49	Country 8Beat
50	Country Rock
51	Country Shuffle
52	Blue Grass
<b>LATIN</b>	
53	Jazz Samba
54	Pop Bossa
55	Guitar Bossa
56	Rhumba 1
57	Guitar Rhumba
58	Samba
59	Mambo
60	<b>Salsa</b>
61	Bossa Nova 1
62	Pop Cha Cha
63	Reggae
64	Pop Reggae
<b>BALL ROOM</b>	
65	Tango
66	Cha Cha
67	Beguine
68	Rhumba 2
69	Samba
70	Bounce
71	Foxtrot
72	Quick Step
73	Jive
<b>TRADITIONAL</b>	
74	March
75	German March
76	6/8 March

77	Polka
78	Polka Pop 1
79	Polka Pop2
80	Waltz 1
81	Slow Waltz
82	Country Waltz
83	Jazz Waltz
84	Orchestra Waltz
85	Musette
<b>PIANIST</b>	
86	Pianist
87	Ballad 2
88	Slow Rock 2
89	Bossa Nova 2
<b>COUNTRY</b>	
90	Dangdut
91	Keroncong
92	Pop Malay
93	Xin Jiang
94	Yun Nan
95	Nei Meng Gu
96	Jiang Nan
97	Oriental 1
98	Oriental 2
99	Oriental 3
100	Oriental 4

# Appendix 3- Song List

P01~37 <b>CLASSICAL</b>	
01	Allegro In BBK003
02	Chant Sans Paroles Op.40 No.6
03	Blue Danube Waltz
04	Violin Sonata In F
05	German Dance No.6
06	Sonata
07	Flute Sonata No.7
08	L'Amour
09	Guitar Quartet
10	Nocturne Op.15 No.2
11	Joy to The World
12	The Song Of Season
13	The Colt Is Taking A Walk
14	The light
15	Happy Landman
16	Old Black Joe
17	O*Sol e Mio
18	Long ㄥ Long Ago
19	The Entertainer
20	Trumpet Voluntary
21	Mazurka For Piano Op.6 No.1
22	Etudes Op.10 No.3 in E Major
23	Etudes Op.10 No.11 in b E Major
24	Arioso
25	Nocturnes OP.32 No.2 in bA
26	Waltz No.2 Op.70
27	Nocturnes Op.62 No.2 in E
28	Nocturnes OP.55 NO.1 in F minor.mid
29	German Dance No.1 in D
30	German Dance No.5 in D
31	Clarinet Polka
32	Mov.2 Adagio Cello Concerto In D Op.101
33	Mov.1 Symphony No.45 In F#
34	Brahms Lullaby
35	Concerto In F Op.4 NO.5 Mov.3
36	Concerto In F Op.4 No.5 Mov.2
37	Divertissement- Pizzicato (Sylvia Ballet)

P38~50 <b>PIANIST</b>	
38	Bagatelle No.3
39	Wedding March
40	Turkish March
41	Four Little Swans
42	Minuet In G
43	Minuet
44	Invent - 2
45	Did You Ever See A Lassie
46	Old France
47	Old Macdonald Had A Farm
48	Moseta Dance
49	Santa Claus Is Coming To Town
50	America The Beautiful

# Appendix 4- Chord List

Chord Name/[Abbreviation]	Normal Voicing	Chord (C)	DISPLAY
Major [M]	1-3-5	C	C
Sixth [6]	1-(3)-5-6	C6	C6
Major seventh[M7]	1-3-(5)-7	CM7	CM7
Major seventh add sharp Eleventh [M7(#11)]	1-(2)-3-#4-5-7 or 1-2-3-#4-(5)-7	CM7(#11)	CM7(#11)
Major add ninth [M(9)]	1-2-3-5	CM(9)	CM (9)
Major seventh ninth [M7(9)]	1-2-3-(5)-7	CM7(9)	CM7 (9)
Sixth ninth [6 (9)]	1-2-3-(5)-6	C6(9)	C6(9)
Augmented [aug]	1-3-#5	Caug	Caug
Minor [m]	1-b3-5	Cm	Cm
Minor sixth [m6]	1-b3-5-6	Cm6	Cm6
Minor seventh [m7]	1-b3-(5)-b7	Cm7	Cm7
Minor seventh flatted fifth [m7b5]	1-b3-b5-b7	Cm7b5	Cm7b5
Minor add ninth [m(9)]	1-2-b3-5	Cm(9)	Cm (9)
Minor seventh ninth [m7(9)]	1-2-b3-(5)-b7	Cm7(9)	Cm7(9)
Minor seventh add eleventh [m7(11)]	1-2-b3-4-5-(b7)	Cm7(11)	Cm7(11)
Minor major seventh [mM7]	1-b3-(5)-7	CmM7	CmM7
Minor major seventh ninth [mM7(9)]	1-2-b3-(5)-7	CmM7(9)	CmM7(9)
Diminished [dim]	1-b3-b5	Cdim	Cdim
Diminished seventh [dim7]	1-b3-b5-6	Cdim7	Cdim7
Seventh [7]	1-3-(5)-b7	C7	C7
Seventh suspended fourth [7sus4]	1-4-5-b7	C7sus4	C7sus4
Seventh flatted fifth [7b5]	1-3-b5-b7	C7b5	C7b5
Seventh ninth [7(9)]	1-2-3-(5)-b7	C7 (9)	C7 (9)
Seventh add sharp eleventh [7(#11)]	1-(2)-3-#4-5-b7 or 1-2-3-#4-(5)-b7	C7(#11)	C7(#11)
Seventh add thirteenth [7 (13)]	1-3-(5)-6-b7	C7(13)	C7 (13)
Seventh flatted Ninth [7(b9)]	1-b2-3-(5)-b7	C7(b9)	C7(b9)
Seventh add flatted thirteen [7(b13)]	1-3-5-b6-b7	C7(b13)	C7(b13)
Seventh sharp ninth [7(#9)]	(1)-#2-3-(5)-b7	C7(#9)	C7 (#9)
Major seventh augmented [M7aug]	1-3-#5-7	CM7aug	CM7aug
Seventh augmented [7aug]	(1)-3-#5-b7	C7aug	C7aug
Suspended Fourth [sus4]	1-4-5	Csus4	Csus4
One plus tow plus five [1+2+5]	1-2-5	C1+2+5	C

# Appendix 5- MIDI List

Function		Transmitted	Recognized	Remarks
Basic Channel	Default Changed	1ch 1ch	1-16ch 1-16ch	
Mode	Default Messages Altered	X X *****	3 X X	
Note Number	True voice	0-127 *****	0...127 0...127	
Velocity :	Note on Noteoff	0 9nH,V=1-127 X (9nH,V=0)	0 9nH,V=1-127 X (9nH,V=0; 8nH,V=0-127)	
After Touch	Keys Chs	X X	X X	
Pitch Bend		0	0	
Control Change	0 1 5 6 7 10 11 64 65 66 67 80 81 91 93 120 121 123	0 0 X 0 0 X X 0 X X X X X X X X X	0 0 0 0 0 0 0 0 0 0 0 0 0 0 0 0 0	Bank Select Modulation Portamento Time Data Entry Volume Pan Expression Sustain Pedal Portamento ON/OFF Sostenuto Pedal Soft Pedal Reverb Program Chorus Program Reverb Level Chorus Level All Sound Off Reset All Controllers All Notes Off
Program Change :	true #	0 *****	0 0...127	
System Exclusive		X	0	
System Common	↳Song Position ↳Song Select : Tune	X X X	X X X	
System Real Time	:Clock :Commands	X X *1	X X *1	
Aux Messages	:LOCAL ON/OFF :All Notes Off :Active sense :Reset	X X X X	X 0 0 0	
Note:	*1 When the accompaniment is started, an FAH message is transmitted. When accompaniment is stopped, an FCH message is transmitted. When an FAH message is received, accompaniment is started. When an FCH message is received, accompaniment is stopped.			

Mode 1: OMNI ON , POLY  
Mode 3: OMNI OFF , POLY

Mode 2 : OMNI ON , MONO    0 : YES  
Mode 4 : OMNI OFF , MONO    X : NO

