

# **MYXmanuals**

## **ORIGINAL FACTORY SERVICE MANUALS**

<http://myxmanuals.infinitehosting.net/>

Thank-you for downloading this manual from Myx manuals. Please come back and see us again. Manuals are updated regularly. If you have a manual you think we should have, please drop us a line, and we will give it a home. Thanks.

[myxstore@gmail.com](mailto:myxstore@gmail.com)

### **LEGAL NOTE**

This is an electronic backup of the Original Factory Service Manual. You should own the original manual to be able to download this backup.

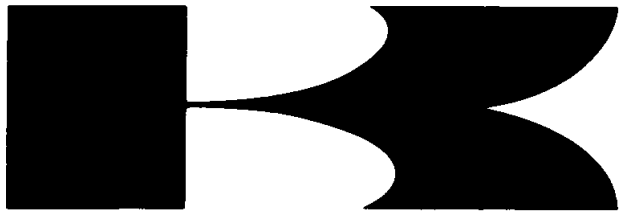

**Kawasaki**

**Ninja ZX-6R**



# **Motorcycle Service Manual**



# Quick Reference Guide

<b>General Information</b>	<b>1</b>
<b>Periodic Maintenance</b>	<b>2</b>
<b>Fuel System (DFI)</b>	<b>3</b>
<b>Cooling System</b>	<b>4</b>
<b>Engine Top End</b>	<b>5</b>
<b>Clutch</b>	<b>6</b>
<b>Engine Lubrication System</b>	<b>7</b>
<b>Engine Removal/Installation</b>	<b>8</b>
<b>Crankshaft/Transmission</b>	<b>9</b>
<b>Wheels/Tires</b>	<b>10</b>
<b>Final Drive</b>	<b>11</b>
<b>Brakes</b>	<b>12</b>
<b>Suspension</b>	<b>13</b>
<b>Steering</b>	<b>14</b>
<b>Frame</b>	<b>15</b>
<b>Electrical System</b>	<b>16</b>
<b>Appendix</b>	<b>17</b>

This quick reference guide will assist you in locating a desired topic or procedure.

- Bend the pages back to match the black tab of the desired chapter number with the black tab on the edge at each table of contents page.
- Refer to the sectional table of contents for the exact pages to locate the specific topic required.





# Ninja ZX-6R

# Motorcycle Service Manual

---

All rights reserved. No parts of this publication may be reproduced, stored in a retrieval system, or transmitted in any form or by any means, electronic mechanical photocopying, recording or otherwise, without the prior written permission of Quality Assurance Department/Consumer Products & Machinery Company/Kawasaki Heavy Industries, Ltd., Japan.

No liability can be accepted for any inaccuracies or omissions in this publication, although every possible care has been taken to make it as complete and accurate as possible.

The right is reserved to make changes at any time without prior notice and without incurring an obligation to make such changes to products manufactured previously. See your Motorcycle dealer for the latest information on product improvements incorporated after this publication.

All information contained in this publication is based on the latest product information available at the time of publication. Illustrations and photographs in this publication are intended for reference use only and may not depict actual model component parts.

## LIST OF ABBREVIATIONS

A	ampere(s)	lb	pound(s)
ABDC	after bottom dead center	m	meter(s)
AC	alternating current	min	minute(s)
ATDC	after top dead center	N	newton(s)
BBDC	before bottom dead center	Pa	pascal(s)
BDC	bottom dead center	PS	horsepower
BTDC	before top dead center	psi	pound(s) per square inch
°C	degree(s) Celsius	r	revolution
DC	direct current	rpm	revolution(s) per minute
F	farad(s)	TDC	top dead center
°F	degree(s) Fahrenheit	TIR	total indicator reading
ft	foot, feet	V	volt(s)
g	gram(s)	W	watt(s)
h	hour(s)	Ω	ohm(s)
L	liter(s)		

**Read OWNER'S MANUAL before operating.**

## EMISSION CONTROL INFORMATION

To protect the environment in which we all live, Kawasaki has incorporated crankcase emission (1) and exhaust emission (2) control systems in compliance with applicable regulations of the United States Environmental Protection Agency and California Air Resources Board. Additionally, Kawasaki has incorporated an evaporative emission control system (3) in compliance with applicable regulations of the California Air Resources Board on vehicles sold in California only.

### 1. Crankcase Emission Control System

This system eliminates the release of crankcase vapors into the atmosphere. Instead, the vapors are routed through an oil separator to the inlet side of the engine. While the engine is operating, the vapors are drawn into combustion chamber, where they are burned along with the fuel and air supplied by the fuel injection system.

### 2. Exhaust Emission Control System

This system reduces the amount of pollutants discharged into the atmosphere by the exhaust of this motorcycle. The fuel, ignition, and exhaust systems of this motorcycle have been carefully designed and constructed to ensure an efficient engine with low exhaust pollutant levels.

The exhaust system of this model motorcycle manufactured primarily for sale in California includes a catalytic converter system.

### 3. Evaporative Emission Control System

Vapors caused by fuel evaporation in the fuel system are not vented into the atmosphere. Instead, fuel vapors are routed into the running engine to be burned, or stored in a canister when the engine is stopped. Liquid fuel is caught by a vapor separator and returned to the fuel tank.

The Clean Air Act, which is the Federal law covering motor vehicle pollution, contains what is commonly referred to as the Act's "tampering provisions".

"Sec. 203(a) The following acts and the causing thereof are prohibited...

(3)(A) for any person to remove or render inoperative any device or element of design installed on or in a motor vehicle or motor vehicle engine in compliance with regulations under this title prior to its sale and delivery to the ultimate purchaser, or for any manufacturer or dealer knowingly to remove or render inoperative any such device or element of design after such sale and delivery to the ultimate purchaser.

(3)(B) for any person engaged in the business of repairing, servicing, selling, leasing, or trading motor vehicles or motor vehicle engines, or who operates a fleet of motor vehicles knowingly to remove or render inoperative any device or element of design installed on or in a motor vehicle or motor vehicle engine in compliance with regulations under this title following its sale and delivery to the ultimate purchaser..."

### NOTE

○ *The phrase "remove or render inoperative any device or element of design" has been generally interpreted as follows.*

1. *Tampering does not include the temporary removal or rendering inoperative of devices or elements of design in order to perform maintenance.*
2. *Tampering could include.*
  - a. *Maladjustment of vehicle components such that the emission standards are exceeded.*
  - b. *Use of replacement parts or accessories which adversely affect the performance or durability of the motorcycle.*
  - c. *Addition of components or accessories that result in the vehicle exceeding the standards.*
  - d. *Permanently removing, disconnecting, or rendering inoperative any component or element of design of the emission control systems.*

**WE RECOMMEND THAT ALL DEALERS OBSERVE THESE PROVISIONS OF FEDERAL LAW, THE VIOLATION OF WHICH IS PUNISHABLE BY CIVIL PENALTIES NOT EXCEEDING \$10 000 PER VIOLATION.**

## **TAMPERING WITH NOISE CONTROL SYSTEM PROHIBITED**

Federal law prohibits the following acts or the causing thereof. (1) The removal or rendering inoperative by any person other than for purposes of maintenance, repair, or replacement, of any device or element of design incorporated into any new vehicle for the purpose of noise control prior to its sale or delivery to the ultimate purchaser or while it is in use, or (2) the use of the vehicle after such device or element of design has been removed or rendered inoperative by any person.

Among those acts presumed to constitute tampering are the acts listed below.

- Replacement of the original exhaust system or muffler with a component not in compliance with Federal regulations.
- Removal of the muffler(s) or any internal portion of the muffler(s).
- Removal of the air box or air box cover.
- Modifications to the muffler(s) or air inlet system by cutting, drilling, or other means if such modifications result in increased noise levels.

# Foreword

This manual is designed primarily for use by trained mechanics in a properly equipped shop. However, it contains enough detail and basic information to make it useful to the owner who desires to perform his own basic maintenance and repair work. A basic knowledge of mechanics, the proper use of tools, and workshop procedures must be understood in order to carry out maintenance and repair satisfactorily. Whenever the owner has insufficient experience or doubts his ability to do the work, all adjustments, maintenance, and repair should be carried out only by qualified mechanics.

In order to perform the work efficiently and to avoid costly mistakes, read the text, thoroughly familiarize yourself with the procedures before starting work, and then do the work carefully in a clean area. Whenever special tools or equipment are specified, do not use makeshift tools or equipment. Precision measurements can only be made if the proper instruments are used, and the use of substitute tools may adversely affect safe operation.

**For the duration of the warranty period,** we recommend that all repairs and scheduled maintenance be performed in accordance with this service manual. Any owner maintenance or repair procedure not performed in accordance with this manual may void the warranty.

To get the longest life out of your vehicle.

- Follow the Periodic Maintenance Chart in the Service Manual.
- Be alert for problems and non-scheduled maintenance.
- Use proper tools and genuine Kawasaki Motorcycle parts. Special tools, gauges, and testers that are necessary when servicing Kawasaki motorcycles are introduced by the Special Tool Catalog or Manual. Genuine parts provided as spare parts are listed in the Parts Catalog.
- Follow the procedures in this manual carefully. Don't take shortcuts.
- Remember to keep complete records of maintenance and repair with dates and any new parts installed.

---

## How to Use This Manual

---

In preparing this manual, we divided the product into its major systems. These systems became the manual's chapters. All information for a particular system from adjustment through disassembly and inspection is located in a single chapter.

The Quick Reference Guide shows you all of the product's system and assists in locating their chapters. Each chapter in turn has its own comprehensive Table of Contents.

The Periodic Maintenance Chart is located in the Periodic Maintenance chapter. The chart gives a time schedule for required maintenance operations.

If you want spark plug information, for example, go to the Periodic Maintenance Chart first. The chart tells you how frequently to clean and gap the plug. Next, use the Quick Reference Guide to locate the Periodic Maintenance chapter. Then, use the Table of Contents on the first page of the chapter to find the Spark Plug section.

Whenever you see these WARNING and CAUTION symbols, heed their instructions! Always follow safe operating and maintenance practices.

### WARNING

**This warning symbol identifies special instructions or procedures which, if not correctly followed, could result in personal injury, or loss of life.**

### CAUTION

**This caution symbol identifies special instructions or procedures which, if not strictly observed, could result in damage to or destruction of equipment.**

This manual contains four more symbols (in addition to WARNING and CAUTION) which will help you distinguish different types of information.

## NOTE

○ *This note symbol indicates points of particular interest for more efficient and convenient operation.*

● Indicates a procedural step or work to be done.

○ Indicates a procedural sub-step or how to do the work of the procedural step it follows. It also precedes the text of a NOTE.

★ Indicates a conditional step or what action to take based on the results of the test or inspection in the procedural step or sub-step it follows.

In most chapters an exploded view illustration of the system components follows the Table of Contents. In these illustrations you will find the instructions indicating which parts require specified tightening torque, oil, grease or a locking agent during assembly.

# General Information

## Table of Contents

Before Servicing .....	1-2
Model Identification.....	1-7
General Specifications.....	1-9
Unit Conversion Table .....	1-12

## 1-2 GENERAL INFORMATION

### Before Servicing

Before starting to perform an inspection service or carry out a disassembly and reassembly operation on a motorcycle, read the precautions given below. To facilitate actual operations, notes, illustrations, photographs, cautions, and detailed descriptions have been included in each chapter wherever necessary. This section explains the items that require particular attention during the removal and reinstallation or disassembly and reassembly of general parts.

Especially note the following.

#### *Battery Ground*

Before completing any service on the motorcycle, disconnect the battery cables from the battery to prevent the engine from accidentally turning over. Disconnect the ground cable (-) first and then the positive (+). When completed with the service, first connect the positive (+) cable to the positive (+) terminal of the battery then the negative (-) cable to the negative terminal.

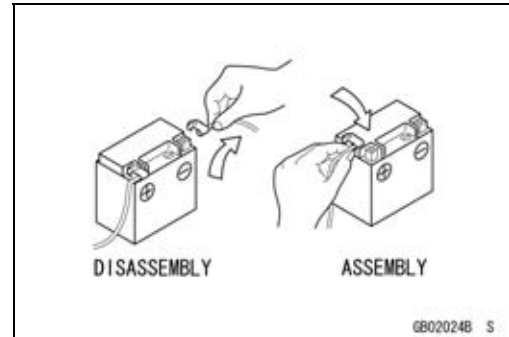

#### *Edges of Parts*

Lift large or heavy parts wearing gloves to prevent injury from possible sharp edges on the parts.

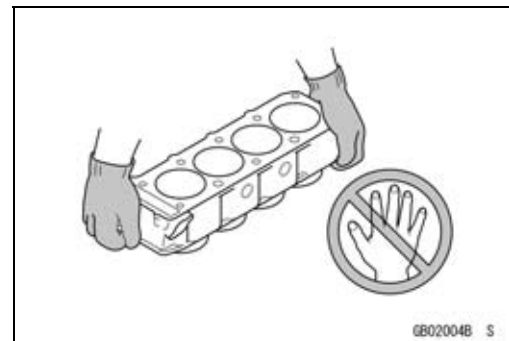

#### *Solvent*

Use a high-flush point solvent when cleaning parts. High-flush point solvent should be used according to directions of the solvent manufacturer.

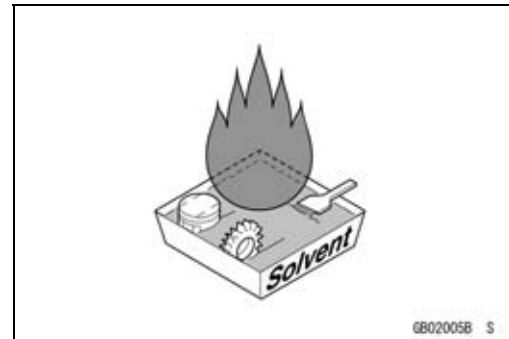

#### *Cleaning vehicle before disassembly*

Clean the vehicle thoroughly before disassembly. Dirt or other foreign materials entering into sealed areas during vehicle disassembly can cause excessive wear and decrease performance of the vehicle.

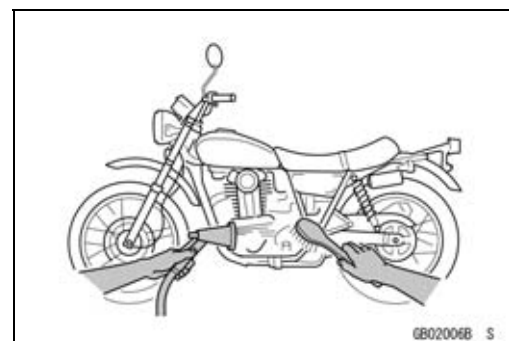

## Before Servicing

### Arrangement and Cleaning of Removed Parts

Disassembled parts are easy to confuse. Arrange the parts according to the order the parts were disassembled and clean the parts in order prior to assembly.

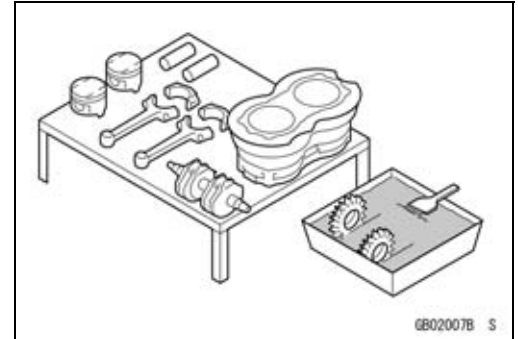

### Storage of Removed Parts

After all the parts including subassembly parts have been cleaned, store the parts in a clean area. Put a clean cloth or plastic sheet over the parts to protect from any foreign materials that may collect before re-assembly.

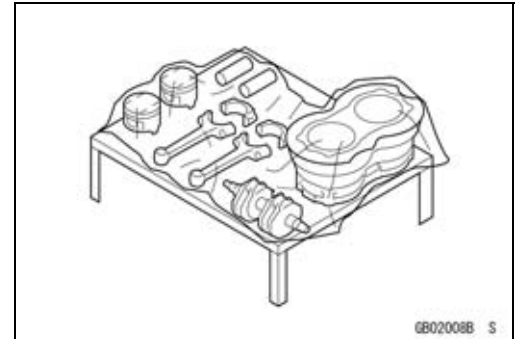

### Inspection

Reuse of worn or damaged parts may lead to serious accident. Visually inspect removed parts for corrosion, discoloration, or other damage. Refer to the appropriate sections of this manual for service limits on individual parts. Replace the parts if any damage has been found or if the part is beyond its service limit.

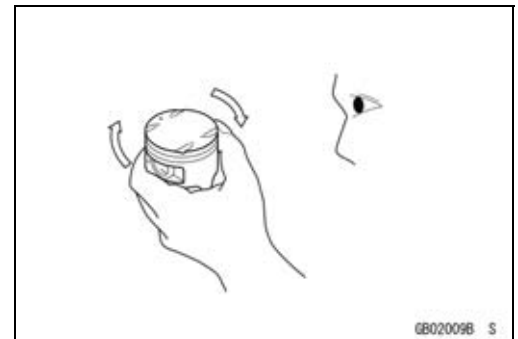

### Replacement Parts

Replacement Parts must be KAWASAKI genuine or recommended by KAWASAKI. Gaskets, O-rings, oil seals, grease seals, circlips or cotter pins must be replaced with new ones whenever disassembled.

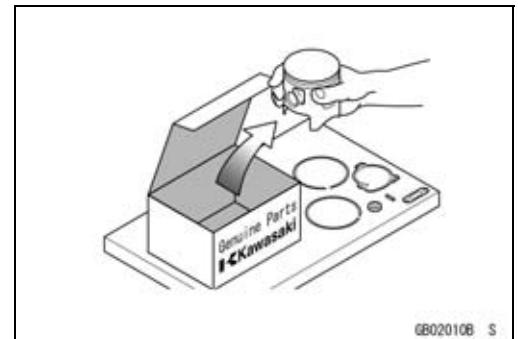

### Assembly Order

In most cases assembly order is the reverse of disassembly, however, if assembly order is provided in this Service Manual, follow the procedures given.

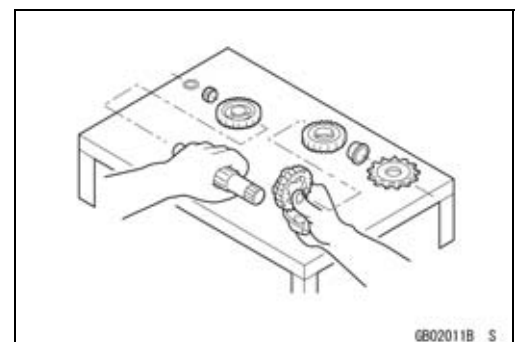

## 1-4 GENERAL INFORMATION

### Before Servicing

#### *Tightening Sequence*

Generally, when installing a part with several bolts, nuts, or screws, start them all in their holes and tighten them to a snug fit. Then tighten them according to the specified sequence to prevent case warpage or deformation which can lead to malfunction. Conversely when loosening the bolts, nuts, or screws, first loosen all of them by about a quarter turn and then remove them. If the specified tightening sequence is not indicated, tighten the fasteners alternating diagonally.

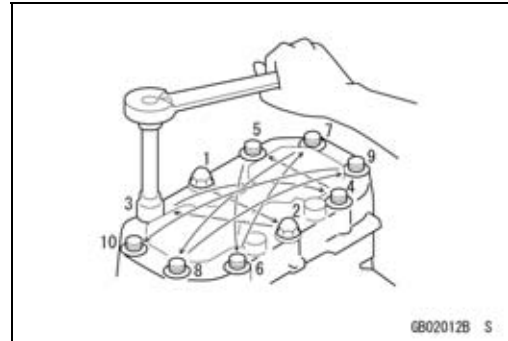

#### *Tightening Torque*

Incorrect torque applied to a bolt, nut, or screw may lead to serious damage. Tighten fasteners to the specified torque using a good quality torque wrench.

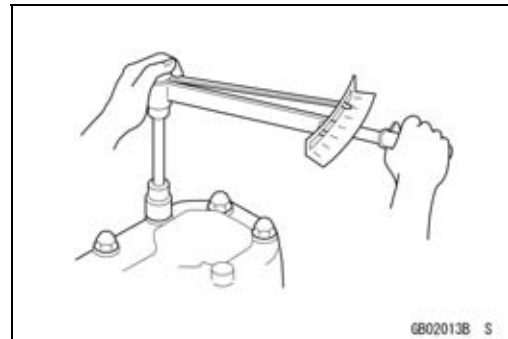

#### *Force*

Use common sense during disassembly and assembly, excessive force can cause expensive or hard to repair damage. When necessary, remove screws that have a non-permanent locking agent applied using an impact driver. Use a plastic-faced mallet whenever tapping is necessary.

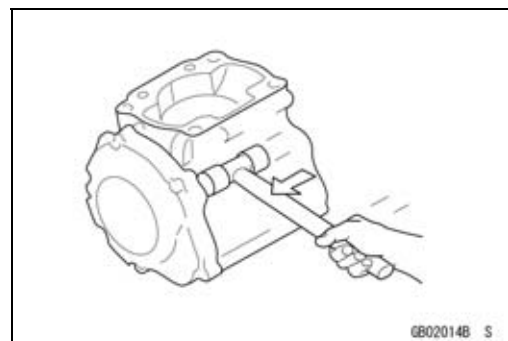

#### *Gasket, O-ring*

Hardening, shrinkage, or damage of both gaskets and O-rings after disassembly can reduce sealing performance. Remove the old gaskets and clean the sealing surfaces thoroughly so that no gasket material or other material remains. Install the new gaskets and replace the used O-rings when re-assembling.

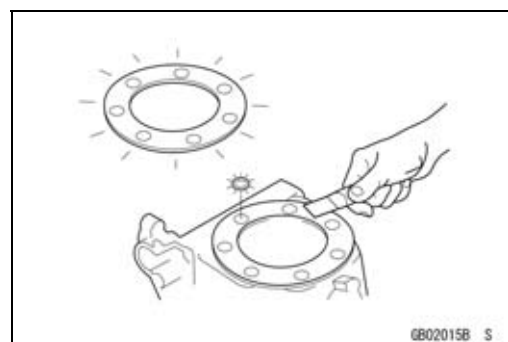

#### *Liquid Gasket, Non-permanent Locking Agent*

For applications that require Liquid Gasket or a Non-permanent Locking Agent, clean the surfaces so that no oil residue remains before applying liquid gasket or non-permanent locking agent. Do not apply them excessively. Excessive application can clog oil passages and cause serious damage.

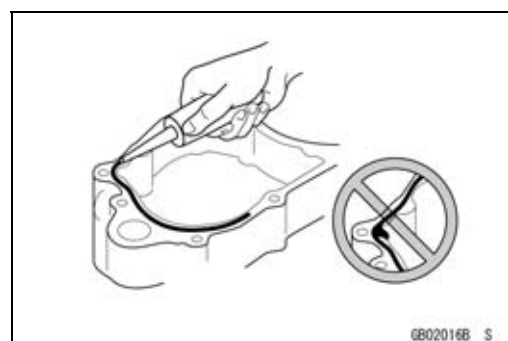

**Before Servicing**

**Press**

For items such as bearings or oil seals that must be pressed into place, apply small amount of oil to the contact area. Be sure to maintain proper alignment and use smooth movements when installing.

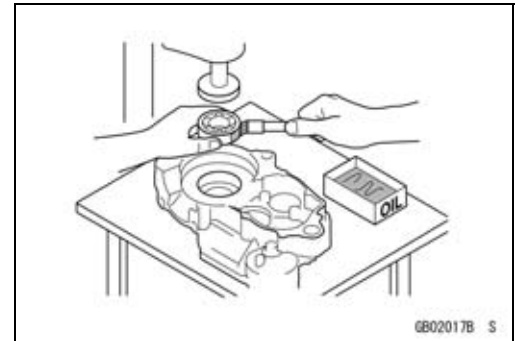

**Ball Bearing and Needle Bearing**

Do not remove pressed ball or needle unless removal is absolutely necessary. Replace with new ones whenever removed. Press bearings with the manufacturer and size marks facing out. Press the bearing into place by putting pressure on the correct bearing race as shown.

Pressing the incorrect race can cause pressure between the inner and outer race and result in bearing damage.

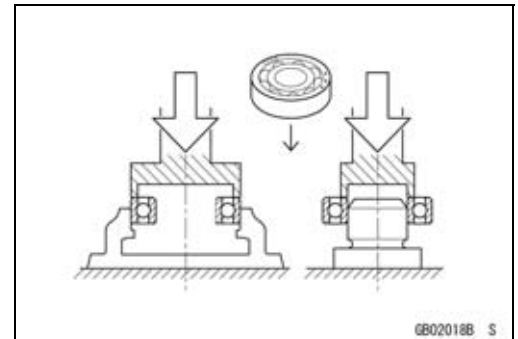

**Oil Seal, Grease Seal**

Do not remove pressed oil or grease seals unless removal is necessary. Replace with new ones whenever removed. Press new oil seals with manufacture and size marks facing out. Make sure the seal is aligned properly when installing.

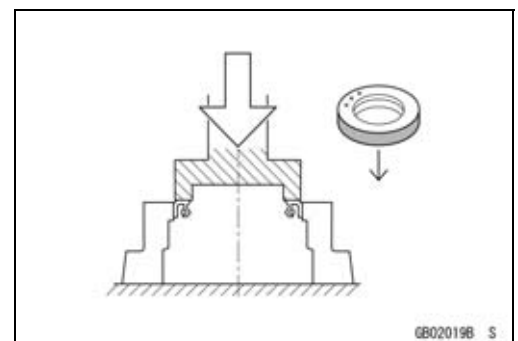

Apply specified grease to the lip of seal before installing the seal.

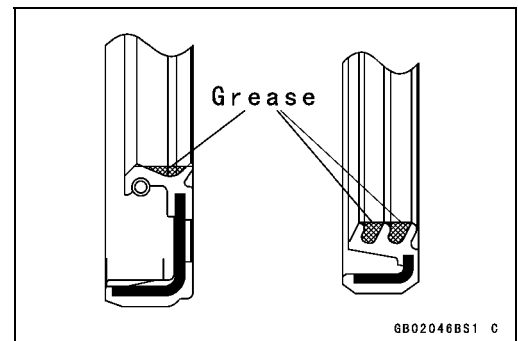

**Circlips, Cotter Pins**

Replace the circlips or cotter pins that were removed with new ones. Take care not to open the clip excessively when installing to prevent deformation.

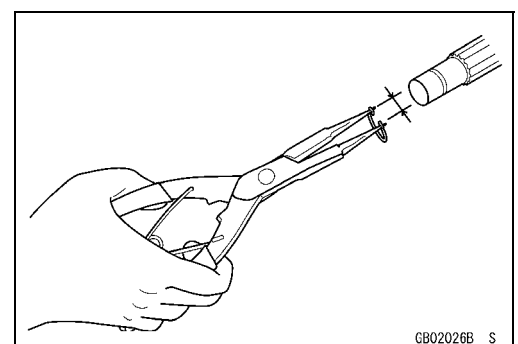

# 1-6 GENERAL INFORMATION

## Before Servicing

### *Lubrication*

It is important to lubricate rotating or sliding parts during assembly to minimize wear during initial operation. Lubrication points are called out throughout this manual, apply the specific oil or grease as specified.

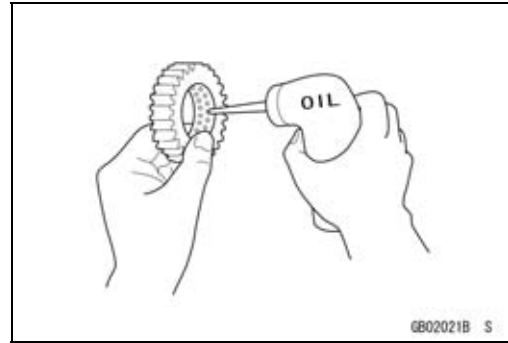

### *Direction of Engine Rotation*

When rotating the crankshaft by hand, the free play amount of rotating direction will affect the adjustment. Rotate the crankshaft to positive direction (clockwise viewed from output side).

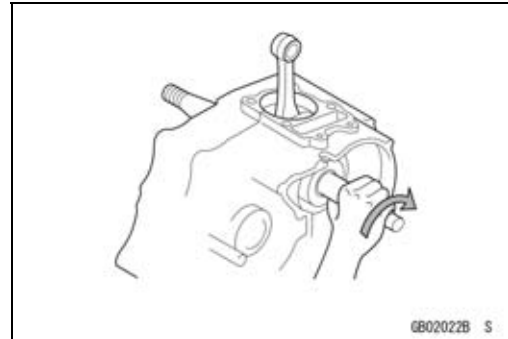

### *Electrical Wires*

A two-color wire is identified first by the primary color and then the stripe color. Unless instructed otherwise, electrical wires must be connected to those of the same color.

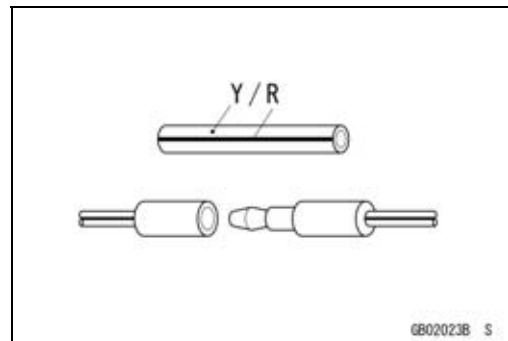

Model Identification

ZX636-C1 (Europe) Left Side View



ZX636-C1 (Europe) Right Side View



## 1-8 GENERAL INFORMATION

### Model Identification

#### ZX636-C1 (US and Canada) Left Side View



#### ZX636-C1 (US and Canada) Right Side View



## General Specifications

Items	ZX636-C1 (Ninja ZX-6R)
<b>Dimensions</b>	
Overall Length	2 065 mm (81.3 in.)
Overall Width	715 mm (28.1 in.)
Overall Height	1 110 mm (43.7 in.)
Wheelbase	1 390 mm (54.7 in.)
Road Clearance	120 mm (4.7 in.)
Seat Height	820 mm (32.3 in.)
Dry Mass	164 kg (362 lb)
Curb Mass:	
Front	95 kg (209 lb)
Rear	97 kg (214 lb)
Fuel Tank Capacity	17 L (4.5 US gal)
<b>Performance</b>	
Minimum Turning Radius	3.3 m (10.8 ft)
<b>Engine</b>	
Type	4-stroke, DOHC, 4-cylinder
Cooling System	Liquid-cooled
Bore and Stroke	68.0 × 43.8 mm (2.7 × 1.7 in.)
Displacement	636 mL (38.8 cu in.)
Compression Ratio	12.9 : 1
Maximum Horsepower	95.5 kW (130 PS) @14 000 r/min (rpm), (FR) 78.2 kW (106 PS) @13 000 r/min (rpm), (MY) 90.8 kW (123 PS) @12 500 r/min (rpm), (CA), (CAL), (US) — — —
Maximum Torque	70.5 N·m (7.1 kgf·m, 52 ft·lb) @11 500 r/min (rpm), (FR) 63 N·m (6.4 kgf·m, 46 ft·lb) @11 500 r/min (rpm), (CA), (CAL), (US) — — —
Carburetion System	FI (Fuel injection) Primary: KEIHIN TTK 38 × 4 Secondary: KEIHIN Multihole (3 holes) × 4
Starting System	Electric starter
Ignition System	Battery and coil (transistorized)
Timing Advance	Electronically advanced (digital igniter in ECU)
Ignition Timing	From 12.5° BTDC @1 300 r/min (rpm) to 35° BTDC @4 600 r/min (rpm)
Spark Plug	NGK CR9E
Cylinder Numbering Method	Left to right, 1-2-3-4
Firing Order	1-2-4-3
Valve Timing:	
Inlet:	
Open	59° BTDC
Close	81° ABDC
Duration	320°
Exhaust:	
Open	61° BBDC
Close	31° ATDC

# 1-10 GENERAL INFORMATION

## General Specifications

Items	ZX636-C1 (Ninja ZX-6R)
Duration	272°
Lubrication System	Forced lubrication (wet sump with cooler)
Engine Oil:	
Type	API SE, SF or SG API SH or SJ with JASO MA
Viscosity	SAE10W-40
Capacity	4.0 L (4.2 US qt)
<b>Drive Train</b>	
Primary Reduction System:	
Type	Gear
Reduction Ratio	1.891 (87/46)
Clutch Type	Wet multi disc
Transmission:	
Type	6-speed, constant mesh, return shift
Gear Ratios:	
1st	2.923 (38/13)
2nd	2.055 (37/18)
3rd	1.666 (35/21)
4th	1.450 (29/20)
5th	1.272 (28/22)
6th	1.153 (30/26)
Final Drive System:	
Type	Chain drive
Reduction Ratio	2.866 (43/15)
Overall Drive Ratio	6.255 @Top gear
<b>Frame</b>	
Type	Tubular, diamond
Caster (Rake Angle)	25°
Trail	106 mm (4.2 in.)
Front Tire:	
Type	Tubeless
Size	120/65 ZR17 M/C (56 W)
Rear Tire:	
Type	Tubeless
Size	180/55 ZR17 M/C (73 W)
Front Suspension:	
Type	Telescopic fork (upside-down)
Wheel Travel	120 mm (4.7 in.)
Rear Suspension:	
Type	Swingarm (uni-trak)
Wheel Travel	135 mm (5.3 in.)
Brake Type:	
Front	Dual discs
Rear	Single disc

---

**General Specifications**

---

Items	ZX636-C1 (Ninja ZX-6R)
<b>Electrical Equipment</b>	
Battery	12 V 8 Ah
Headlight:	
Type	Semi-sealed beam
Bulb:	
High	12 V 55 W (quartz-halogen) × 2
Low	12 V 55 W (quartz-halogen)
Tail/Brake Light	12 V 0.5/4.1 W (LED)
Alternator:	
Type	Three-phase AC
Rated Output	22.5 A/14 V @5 000 r/min (rpm)

Specifications subject to change without notice, and may not apply to every country.

CA: Canada Model

CAL: California Model

FR: France Model

MY: Malaysia Model

US: United States Model

# 1-12 GENERAL INFORMATION

## Unit Conversion Table

### Prefixes for Units

Prefix	Symbol	Power
mega	M	× 1 000 000
kilo	k	× 1 000
centi	c	× 0.01
milli	m	× 0.001
micro	μ	× 0.000001

### Units of Mass

kg	×	2.205	=	lb
g	×	0.03527	=	oz

### Units of Volume

L	×	0.2642	=	gal (US)
L	×	0.2200	=	gal (imp)
L	×	1.057	=	qt (US)
L	×	0.8799	=	qt (imp)
L	×	2.113	=	pint (US)
L	×	1.816	=	pint (imp)
mL	×	0.03381	=	oz (US)
mL	×	0.02816	=	oz (imp)
mL	×	0.06102	=	cu in

### Units of Force

N	×	0.1020	=	kg
N	×	0.2248	=	lb
kg	×	9.807	=	N
kg	×	2.205	=	lb

### Units of Length

km	×	0.6214	=	mile
m	×	3.281	=	ft
mm	×	0.03937	=	in

### Units of Torque

N·m	×	0.1020	=	kgf·m
N·m	×	0.7376	=	ft·lb
N·m	×	8.851	=	in·lb
kgf·m	×	9.807	=	N·m
kgf·m	×	7.233	=	ft·lb
kgf·m	×	86.80	=	in·lb

### Units of Pressure

kPa	×	0.01020	=	kgf/cm <sup>2</sup>
kPa	×	0.1450	=	psi
kPa	×	0.7501	=	cmHg
kgf/cm <sup>2</sup>	×	98.07	=	kPa
kgf/cm <sup>2</sup>	×	14.22	=	psi
cmHg	×	1.333	=	kPa

### Units of Speed

km/h	×	0.6214	=	mph
------	---	--------	---	-----

### Units of Power

kW	×	1.360	=	PS
kW	×	1.341	=	HP
PS	×	0.7355	=	kW
PS	×	0.9863	=	HP

### Units of Temperature

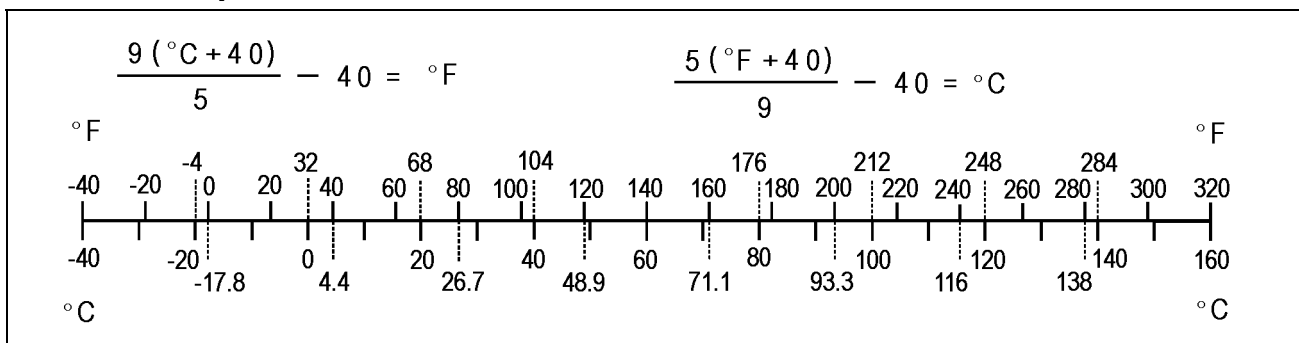

# Periodic Maintenance

## Table of Contents

Periodic Maintenance Chart (United States, Canada Model).....	2-3
Periodic Maintenance Chart (Other than United States, Canada Model).....	2-6
Torque and Locking Agent.....	2-9
Specifications .....	2-15
Special Tools .....	2-17
Maintenance Procedure .....	2-18
Fuel System (DFI).....	2-18
Throttle Control System Inspection.....	2-18
Engine Vacuum Synchronization Inspection.....	2-18
Idle Speed Inspection .....	2-22
Idle Speed Adjustment.....	2-22
Fuel Hose Damage and Installation Condition Inspection .....	2-22
Evaporative Emission Control System (California Model).....	2-23
Evaporative Emission Control System Inspection .....	2-23
Cooling System.....	2-24
Coolant Level Inspection.....	2-24
Radiator Hose Damage and Installation Condition Inspection.....	2-24
Engine Top End .....	2-25
Valve Clearance Inspection .....	2-25
Valve Clearance Adjustment.....	2-26
Air Suction System .....	2-29
Air Suction System Damage Inspection.....	2-29
Clutch.....	2-29
Clutch Operation Inspection .....	2-29
Wheels/Tires.....	2-30
Air Pressure Inspection.....	2-30
Wheel/Tire Damage Inspection.....	2-30
Tire Tread Wear Inspection .....	2-30
Wheel Bearing Damage Inspection .....	2-31
Drive Train .....	2-32
Drive Chain Lubrication Condition Inspection .....	2-32
Drive Chain Slack Inspection .....	2-32
Drive Chain Slack Adjustment .....	2-33
Wheel Alignment Inspection .....	2-34
Drive Chain Wear Inspection .....	2-34
Chain Guide Wear Inspection .....	2-35
Brake System .....	2-35
Brake Fluid Leak (Brake Hose and Pipe) Inspection .....	2-35
Brake Hose Damage and Installation Condition Inspection.....	2-35
Brake Operation Inspection .....	2-35
Brake Fluid Level Inspection.....	2-36
Brake Pad Wear Inspection .....	2-36
Brake Light Switch Operation Inspection .....	2-36
Suspensions .....	2-37
Front Forks/Rear Shock Absorber Operation Inspection .....	2-37
Front Fork Oil Leak Inspection.....	2-38

## 2-2 PERIODIC MAINTENANCE

---

Rear Shock Absorber Oil Leak Inspection .....	2-38
Rocker Arm Operation Inspection .....	2-38
Tie-Rod Operation Inspection .....	2-38
Steering System .....	2-39
Steering Play Inspection .....	2-39
Steering Play Adjustment.....	2-39
Steering Stem Bearing Lubrication .....	2-40
Electrical System .....	2-40
Spark Plug Clean and Gap Inspection.....	2-40
Lights and Switches Operation Inspection.....	2-42
Headlight Aiming Inspection .....	2-44
Side Stand Switch Operation Inspection.....	2-45
Engine Stop Switch Operation Inspection.....	2-46
Others .....	2-47
Chassis Parts Lubrication .....	2-47
Bolts, Nuts and Fasteners Tightness Inspection.....	2-48
Replacement Parts .....	2-50
Air Cleaner Element Replacement.....	2-50
Fuel Hose Replacement .....	2-50
Coolant Change .....	2-52
Radiator Hose and O-ring Replacement.....	2-54
Engine Oil Change.....	2-55
Oil Filter Replacement .....	2-55
Brake Hose and Pipe Replacement.....	2-56
Brake Fluid Change .....	2-56
Master Cylinder Rubber Parts Replacement .....	2-58
Caliper Rubber Parts Replacement .....	2-59
Spark Plug Replacement .....	2-62

## PERIODIC MAINTENANCE 2-3

### Periodic Maintenance Chart (United States, Canada Model)

The scheduled maintenance must be done in accordance with this chart to keep the motorcycle in good running condition. **The initial maintenance is vitally important and must not be neglected.**

#### Periodic Inspection

INSPECTION	FREQUENCY	* ODOMETER READING							See Page
		Whichever comes first ↓ Every	1 (0.6)	6 (4)	12 (7.5)	18 (12)	24 (15)	30 (20)	
<b>Fuel System</b>									
Throttle control system (play, smooth return, no drag)-inspect	year	•		•		•		•	2-18
Engine vacuum synchronization-inspect				•		•		•	2-18
Idle speed-inspect		•		•		•		•	2-22
Fuel leak (fuel hose and pipe)-inspect	year	•		•		•		•	2-22
Fuel hose and pipe damage-inspect	year	•		•		•		•	2-22
Fuel hose and pipe installation condition-inspect	year	•		•		•		•	2-22
<b>Evaporative Emission Control System (CAL)</b>									
Evaporative emission control system function-inspect			•	•	•	•	•	•	2-23
<b>Cooling System</b>									
Coolant level-inspect		•		•		•		•	2-24
Coolant leak (radiator hose and pipe)-inspect	year	•		•		•		•	2-24
Radiator hose damage-inspect	year	•		•		•		•	2-24
Radiator hose installation condition-inspect	year	•		•		•		•	2-24
<b>Engine Top End</b>									
Valve clearance-inspect						•			2-25
<b>Air Suction System</b>									
Air suction system damage-inspect				•		•		•	2-29
<b>Clutch</b>									
Clutch operation (play, disengagement, engagement)-inspect		•		•		•		•	2-29
<b>Wheels and Tires</b>									
Tire air pressure-inspect	year			•		•		•	2-30
Wheel/tire damage-inspect				•		•		•	2-30
Tire tread wear, abnormal wear-inspect				•		•		•	2-30
Wheel bearing damage-inspect	year			•		•		•	2-31
<b>Drive Train</b>									
Drive chain lubrication condition-inspect #	Every 600 km (400 mile)								2-32
Drive chain slack-inspect #	Every 1 000 km (600 mile)								2-32
Drive chain wear-inspect #				•		•		•	2-34
Drive chain guide wear-inspect				•		•		•	2-35

## 2-4 PERIODIC MAINTENANCE

### Periodic Maintenance Chart (United States, Canada Model)

INSPECTION	FREQUENCY	* ODOMETER READING × 1 000 km (× 1 000 mile)							See Page
	↓ Every	1 (0.6)	6 (4)	12 (7.5)	18 (12)	24 (15)	30 (20)	36 (24)	
<b>Brake System</b>									
Brake fluid leak (brake hose and pipe)-inspect	year	•	•	•	•	•	•	•	2-35
Brake hose and pipe damage-inspect	year	•	•	•	•	•	•	•	2-35
Brake pad wear-inspect #			•	•	•	•	•	•	2-36
Brake hose installation condition-inspect	year	•	•	•	•	•	•	•	2-35
Brake fluid level-inspect	6 months	•	•	•	•	•	•	•	2-36
Brake operation (effectiveness, play, no drag)-inspect	year	•	•	•	•	•	•	•	2-35
Brake light switch operation-inspect		•	•	•	•	•	•	•	2-36
<b>Suspensions</b>									
Front forks/rear shock absorber operation (damping and smooth stroke)-inspect				•		•		•	2-37
Front forks/rear shock absorber oil leak-inspect	year			•		•		•	2-38
Rocker arm operation-inspect				•		•		•	2-38
Tie-Rods operation-inspect				•		•		•	2-38
<b>Steering System</b>									
Steering play-inspect	year	•		•		•		•	2-39
Steering stem bearings-lubricate	2 years					•			2-40
<b>Electrical System</b>									
Spark plug condition – inspect				•		•		•	2-40
Lights and switches operation-inspect	year			•		•		•	2-42
Headlight aiming-inspect	year			•		•		•	2-44
Side stand switch operation-inspect	year			•		•		•	2-45
Engine stop switch operation-inspect	year			•		•		•	2-46
<b>Others</b>									
Chassis parts-lubricate	year			•		•		•	2-47
Bolts and nuts tightness-inspect		•		•		•		•	2-48

\*: For higher odometer readings, repeat at the frequency interval established here.

#: Service more frequently when operating in severe conditions; dusty, wet, muddy, high speed or frequent starting/stopping.

CAL: California Model

## PERIODIC MAINTENANCE 2-5

### Periodic Maintenance Chart (United States, Canada Model)

#### Periodic Replacement Parts

CHANGE/REPLACE ITEM	FREQUENCY	* ODOMETER READING × 1 000 km (× 1 000 mile)					See Page
		Whichever come first ↓ Every	1 (0.6)	12 (7.5)	24 (15)	36 (24)	
Air cleaner element #		Every 18 000 km (12 000 mile)					2-50
Fuel hose	4 years					●	2-50
Coolant	3 years				●		2-52
Radiator hose and O-ring	3 years				●		2-54
Engine oil #	year	●	●	●	●	●	2-55
Oil filter	year	●	●	●	●	●	2-55
Brake hose and pipe	4 years					●	2-56
Brake fluid	2 years			●		●	2-56
Rubber parts of master cylinder and caliper	4 years					●	2-58, 2-59
Spark plug			●	●	●	●	2-62

\*: For higher odometer readings, repeat at the frequency interval established here.

#: Service more frequently when operating in severe conditions; dusty, wet, muddy, high speed or frequent starting/stopping.



## PERIODIC MAINTENANCE 2-7

### Periodic Maintenance Chart (Other than United States, Canada Model)

FREQUENCY	Whichever comes first ↓	* ODOMETER READING × 1 000 km (× 1 000 mile)							See Page
		1 (0.6)	6 (4)	12 (7.5)	18 (12)	24 (15)	30 (20)	36 (24)	
INSPECTION	Every								
Brake hose and pipe damage-inspect	year	•	•	•	•	•	•	•	2-35
Brake pad wear-inspect #			•	•	•	•	•	•	2-36
Brake hose installation condition-inspect	year	•	•	•	•	•	•	•	2-35
Brake fluid level-inspect	6 months	•	•	•	•	•	•	•	2-36
Brake operation (effectiveness, play, no drag)-inspect	year	•	•	•	•	•	•	•	2-35
Brake light switch operation-inspect		•	•	•	•	•	•	•	2-36
<b>Suspensions</b>									
Front forks/rear shock absorber operation (damping and smooth stroke)-inspect				•		•		•	2-37
Front forks/rear shock absorber oil leak-inspect	year			•		•		•	2-38
Rocker arm operation-inspect				•		•		•	2-38
Tie-Rods operation-inspect				•		•		•	2-38
<b>Steering System</b>									
Steering play-inspect	year	•		•		•		•	2-39
Steering stem bearings-lubricate	2 years					•			2-40
<b>Electrical System</b>									
Spark plug condition – inspect				•		•		•	2-40
Lights and switches operation-inspect	year			•		•		•	2-42
Headlight aiming-inspect	year			•		•		•	2-44
Side stand switch operation-inspect	year			•		•		•	2-45
Engine stop switch operation-inspect	year			•		•		•	2-46
<b>Others</b>									
Chassis parts-lubricate	year			•		•		•	2-47
Bolts and nuts tightness-inspect		•		•		•		•	2-48

\*: For higher odometer readings, repeat at the frequency interval established here.

#: Service more frequently when operating in severe conditions; dusty, wet, muddy, high speed or frequent starting/stopping.

## 2-8 PERIODIC MAINTENANCE

### Periodic Maintenance Chart (Other than United States, Canada Model)

#### Periodic Replacement Parts

FREQUENCY	Whichever come first ↓	* ODOMETER READING × 1 000 km (× 1 000 mile)					See Page
		1 (0.6)	12 (7.5)	24 (15)	36 (24)	48 (30)	
CHANGE/REPLACE ITEM	Every						
Air cleaner element #	Every 18 000 km (12 000 mile)						2-50
Fuel hose	4 years					●	2-50
Coolant	3 years				●		2-52
Radiator hose and O-ring	3 years				●		2-54
Engine oil #	year	●	●	●	●	●	2-55
Oil filter	year	●	●	●	●	●	2-55
Brake hose and pipe	4 years					●	2-56
Brake fluid	2 years			●		●	2-56
Rubber parts of master cylinder and caliper	4 years					●	2-58, 2-59
Spark plug			●	●	●	●	2-62

\*: For higher odometer readings, repeat at the frequency interval established here.

#: Service more frequently when operating in severe conditions; dusty, wet, muddy, high speed or frequent starting/stopping.

**Torque and Locking Agent**

The following tables list the tightening torque for the major fasteners requiring use of a non-permanent locking agent or silicone sealant etc.

Letters used in the “Remarks” column mean:

AL: Tighten the two clamp bolts alternately two times to ensure even tightening torque.

G: Apply grease to the threads.

L: Apply a non-permanent locking agent to the threads.

MO: Apply molybdenum disulfide grease oil solution.

R: Replacement Parts

S: Tighten the fasteners following the specified sequence.

SI: Apply silicone grease.

SS: Apply silicone sealant.

Fastener	Torque			Remarks
	N·m	kgf·m	ft·lb	
<b>Fuel System</b>				
Air Cleaner Housing Clamp Bolts	2.0	0.20	17 in·lb	
Air Cleaner Housing Mounting Bolt	6.9	0.70	61 in·lb	
Air Inlet Duct Mounting Bolts	6.9	0.70	61 in·lb	L
Canister Bracket Mounting Bolt (M6)	6.9	0.70	61 in·lb	
Canister Bracket Mounting Bolt (M5)	0.4	0.04	4 in·lb	
Camshaft Position Sensor Bolt	12	1.2	104 in·lb	
Crankshaft Sensor Bolts	5.9	0.60	52 in·lb	
Delivery Pipe Mounting Screws (Nozzle Assy)	3.4	0.35	30 in·lb	
Delivery Pipe Mounting Screws (Throttle Body)	3.4	0.35	30 in·lb	
Exhaust Butterfly Valve Actuator Mounting Bolts	6.9	0.70	61 in·lb	
Exhaust Butterfly Valve Actuator Pulley Bolt	4.9	0.50	43 in·lb	
Fuel Hose Mounting Screw	4.9	0.50	43 in·lb	
Fuel Pump Bolts	9.8	1.0	87 in·lb	L, S
Nozzle Assy Mounting Bolts	6.9	0.70	61 in·lb	
Separator Bracket Mounting Bolt	0.8	0.08	7 in·lb	
Throttle Body Assembly Holder Clamp Bolts	3.0	0.30	27 in·lb	
Throttle Body Holder Bolts	12	1.2	104 in·lb	L
Throttle Cable Holder Bolt	3.9	0.40	35 in·lb	
Vehicle-down Sensor Bolts	5.9	0.60	52 in·lb	
Water Temperature Sensor	25	2.5	18	SS
<b>Cooling System</b>				
Coolant By-pass Fitting Bolt	8.8	0.90	78 in·lb	L
Coolant Drain Bolt (Cylinder)	9.8	1.0	87 in·lb	
Coolant Drain Bolt (Water Pump)	8.8	0.90	78 in·lb	
Coolant Reserve Tank Mounting Bolts	6.9	0.70	61 in·lb	
Impeller Bolt	9.8	1.0	87 in·lb	
Oil Cooler Mounting Bolts	12	1.2	104 in·lb	S
Radiator Bracket Mounting Bolt	6.9	0.70	61 in·lb	
Radiator Lower Bolt	6.9	0.70	61 in·lb	
Radiator Upper Bolt	12	1.2	104 in·lb	
Thermostat Housing Cover Bolts	5.9	0.60	52 in·lb	
Water Hose Clamp Screws	2.0	0.20	17 in·lb	

## 2-10 PERIODIC MAINTENANCE

### Torque and Locking Agent

Fastener	Torque			Remarks
	N·m	kgf·m	ft·lb	
Water Hose Fitting Bolts	12	1.2	104 in·lb	
Water Pump Cover Bolts	12	1.2	104 in·lb	L
Water Temperature Sensor	25	2.5	18	SS
<b>Engine Top End</b>				
Air Suction Valve Cover Bolts	12	1.2	104 in·lb	L
Camshaft Cap Bolts	12	1.2	104 in·lb	S
Camshaft Chain Tensioner Cap Bolt	20	2.0	15	
Camshaft Chain Tensioner Mounting Bolts	11	1.1	97 in·lb	
Cam Sprocket Mounting Bolts	15	1.5	11	L
Coolant Drain Bolt (Cylinder)	9.8	1.0	87 in·lb	
Crankshaft Sensor Cover Bolts	9.8	1.0	87 in·lb	L (1)
Cylinder Head Bolts (M9)	39	4.0	29	MO, S
Cylinder Head Bolts (M6)	12	1.2	104 in·lb	S
Cylinder Head Cover Bolts	9.8	1.0	87 in·lb	
Exhaust Butterfly Valve Actuator Mounting Bolts	6.9	0.70	61 in·lb	
Exhaust Butterfly Valve Actuator Pulley Bolt	4.9	0.50	43 in·lb	
Exhaust Butterfly Valve Cable Adjuster Locknuts	6.9	0.70	61 in·lb	
Exhaust Butterfly Valve Cable Locknuts	6.9	0.70	61 in·lb	
Exhaust Butterfly Valve Cover Bolt	6.9	0.70	61 in·lb	
Exhaust Pipe Clamp Bolt	17	1.7	12	
Exhaust Pipe Manifold Holder Nuts	17	1.7	12	
Exhaust Pipe Mounting Bolt	25	2.5	18	
Front Camshaft Chain Guide Bolt (Lower)	12	1.2	104 in·lb	
Front Camshaft Chain Guide Bolt (Upper)	25	2.5	18	
Muffler Body Clamp Bolt	17	1.7	12	
Muffler Body Mounting Bolts	25	2.5	18	
Muffler Rear Cover Bolts	6.9	0.70	61 in·lb	
Muffler Upper Cover Bolts	6.9	0.70	61 in·lb	
Rear Camshaft Chain Guide Bolt	25	2.5	18	
Spark Plugs	13	1.3	113 in·lb	
Throttle Body Assy Holder Clamp Bolts	2.9	0.30	26 in·lb	
Throttle Body Holder Bolts	12	1.2	104 in·lb	L
Water Passage Plug (Left)	20	2.0	15	L
Water Passage Plugs (Upper)	20	2.0	15	L
<b>Clutch</b>				
Clutch Cover Bolt (M6, L = 50 mm)	12	1.2	104 in·lb	
Clutch Cover Bolt (M6, L = 40 mm)	12	1.2	104 in·lb	L (1)
Clutch Cover Bolts (M6, L = 30 mm)	12	1.2	104 in·lb	L (1)
Clutch Hub Nut	135	14	100	R
Clutch Lever Clamp Bolts	7.8	0.80	69 in·lb	S
Clutch Spring Bolts	8.8	0.90	78 in·lb	
Oil Filler Plug	1.5	0.15	13 in·lb	
Sub Clutch Hub Bolts	25	2.5	18	L

**Torque and Locking Agent**

Fastener	Torque			Remarks
	N·m	kgf·m	ft·lb	
<b>Engine Lubrication System</b>				
Coolant Drain Bolt (Water Pump)	8.8	0.90	78 in·lb	
Engine Oil Drain Bolt	29	3.0	22	
Impeller Bolt	9.8	1.0	87 in·lb	
Oil Cooler Mounting Bolts	12	1.2	104 in·lb	S
Oil Filter	31	3.2	23	EO, R
Oil Filter Mounting Bolt	25	2.5	18	L
Oil Jet Nozzle Bolts	6.9	0.70	61 in·lb	L
Oil Pan Bolts	9.8	1.0	87 in·lb	
Oil Pan Clamp Bolt	9.8	1.0	87 in·lb	
Oil Passage Plug (Left Side)	20	2.0	15	L
Oil Passage Plug (Right Side)	15	1.5	11	
Oil Pipe Bolts	12	1.2	104 in·lb	
Oil Pressure Relief Valve	15	1.5	11	L
Oil Pressure Switch	15	1.5	11	SS
Oil Pressure Switch Terminal Bolt	1.5	0.15	13 in·lb	
Water Hose Clamp Screws	2.0	0.20	17 in·lb	
Water Pump Cover Bolts	12	1.2	104 in·lb	L
<b>Engine Removal/Installation</b>				
Adjusting Collar Locknut	49	5.0	36	S
Lower Engine Mounting Bolt	10	1.0	87 in·lb	S
Lower Engine Mounting Nut	44	4.5	33	S
Middle Engine Mounting Bolt	10	1.0	87 in·lb	S
Middle Engine Mounting Nut	44	4.5	33	S
Upper Engine Mounting Bolts	44	4.5	33	S
<b>Crankshaft/Transmission</b>				
Breather Plate Bolts	5.9	0.60	52 in·lb	L
Connecting Rod Big End Nuts	see the text	←	←	←
Crankcase Bolts (M8)	31	3.2	23	MO, S
Crankcase Bolts (M7, L = 38 mm)	27	2.8	20	S
Crankcase Bolt (M7, L = 70 mm)	20	2.0	14	S
Crankcase Bolts (M6, L = 65 mm)	12	1.2	104 in·lb	S
Crankcase Bolts (M6, L = 50 mm)	12	1.2	104 in·lb	S
Crankcase Bolts (M6, L = 38 mm)	12	1.2	104 in·lb	S
Crankcase Bolt (M6, L = 95 mm)	12	1.2	104 in·lb	S
Crankcase Bolt (M6, L = 85 mm)	12	1.2	104 in·lb	S
Crankcase Bolt (M6, L = 35 mm)	12	1.2	104 in·lb	S
Neutral Switch	15	1.5	11	L
Gear Positioning Lever Bolt	12	1.2	104 in·lb	
Harness Clamp Bolt	8.8	0.90	78 in·lb	L
Oil Passage Plug (Left Side)	20	2.0	15	L
Oil Passage Plug (Right Side)	15	1.5	11	
Oil Pressure Switch	15	1.5	11	SS

## 2-12 PERIODIC MAINTENANCE

### Torque and Locking Agent

Fastener	Torque			Remarks
	N·m	kgf·m	ft·lb	
Oil Pressure Switch Terminal Bolt	1.5	0.15	13 in·lb	
Plate Screws	5.9	0.60	52 in·lb	L
Shift Drum Bearing Holder Bolts	12	1.2	104 in·lb	L
Shift Drum Cam Holder Bolt	12	1.2	104 in·lb	L
Shift Lever Bolt	6.9	0.70	61 in·lb	
Shift Pedal Mounting Bolt	25	2.5	18	
Shift Shaft Return Spring Pin	28	2.9	21	L
Tie-Rod Locknuts	6.9	0.70	61 in·lb	
<b>Wheels/Tires</b>				
Front Axle Clamp Bolts	20	2.0	15	AL
Front Axle Nut	127	13	94	
Rear Axle Nut	127	13	94	
<b>Final Drive</b>				
Engine Sprocket Cover Bolts	6.9	0.70	61 in·lb	
Engine Sprocket Nut	125	13	92	MO
Rear Axle Nut	127	13	94	
Rear Sprocket Nuts	59	6.0	43	
<b>Brakes</b>				
Bleed Valves	7.8	0.80	69 in·lb	
Brake Hose Banjo Bolts	34	3.5	25	
Brake Lever Pivot Bolt	1.0	0.10	9 in·lb	SI
Brake Lever Pivot Bolt Locknut	5.9	0.60	52 in·lb	
Brake Pedal Bolt	8.8	0.90	78	
Front Brake Light Switch Screw	1.2	0.12	10 in·lb	
Front Brake Reservoir Cap Stopper Screw	1.2	0.12	10 in·lb	
Front Brake Disc Mounting Bolts	27	2.8	20	L
Front Brake Pad Pins	15	1.5	11	
Front Caliper Assembly Bolts	22	2.2	16	
Front Caliper Mounting Bolts	34	3.5	25	
Front Master Cylinder Bleed Valve	5.9	0.60	52 in·lb	
Front Master Cylinder Clamp Bolts	8.8	0.90	78 in·lb	S
Rear Brake Disc Mounting Bolts	27	2.8	20	L
Rear Caliper Mounting Bolts	25	2.5	18	
Rear Master Cylinder Mounting Bolts	25	2.5	18	
Rear Master Cylinder Push Rod Locknut	18	1.8	13	
<b>Suspension</b>				
Front Axle Clamp Bolts	20	2.0	15	AL
Front Fork Bottom Allen Bolts	35	3.5	26	L
Front Fork Clamp Bolts (Lower)	25	2.5	18	AL
Front Fork Clamp Bolts (Upper)	20	2.0	15	
Front Fork Top Plugs	35	3.5	26	
Piston Rod Nuts	20	2.0	15	
Rear Shock Absorber Bracket Nut	59	6.0	43	

**Torque and Locking Agent**

Fastener	Torque			Remarks
	N·m	kgf·m	ft·lb	
Rear Shock Absorber Nut (Lower)	34	3.5	25	
Rear Shock Absorber Nut (Upper)	34	3.5	25	
Swingarm Pivot Adjusting Collar	20	2.0	15	
Swingarm Pivot Adjusting Collar Locknut	98	10	72	
Swingarm Pivot Shaft Nut	108	11	81	
Tie-Rod Nuts	59	6.0	43	
Uni-Trak Rocker Arm Nut	34	3.5	25	
<b>Steering</b>				
Front Fork Clamp Bolts (Lower)	25	2.5	18	AL
Front Fork Clamp Bolts (Upper)	20	2.0	15	
Handlebar Bolts	25	2.5	18	
Handlebar Position Bolts	9.8	1.0	87 in·lb	L
Steering Stem Head Nut	78	8.0	58	
Steering Stem Nut	20	2.0	15	
Switch Housing Screws	3.5	0.36	31 in·lb	
<b>Frame</b>				
Air Inlet Duct Mounting Bolts	6.9	0.70	61	L
Front Fender Mounting Bolts	3.9	0.40	35 in·lb	
Front Footpeg Bracket Bolts	25	2.5	18	
Rear Footpeg Bracket Bolts	25	2.5	18	
Rear Frame Bolts	59	6.0	44	L (2)
Side Stand Bolt	44	4.5	32	G
Side Stand Bracket Bolts	49	5.0	36	L
Side Stand Switch Bolt	8.8	0.90	78 in·lb	L
Side Stand Switch Bracket Bolt	3.9	0.40	35 in·lb	L
Windshield Mounting Bolts	0.4	0.04	4 in·lb	
<b>Electrical System</b>				
Alternator Cover Bolts	12	1.2	104 in·lb	
Alternator Lead Holding Plate Bolts	6.9	0.70	61 in·lb	L
Alternator Rotor Bolt	110	11	81	
Camshaft Position Sensor Bolt	12	1.2	104 in·lb	
Crankshaft Sensor Bolts	5.9	0.60	52 in·lb	
Crankshaft Sensor Cover Bolts	9.8	1.0	87 in·lb	L (1)
Engine Ground Lead Terminal Bolt	9.8	1.0	87 in·lb	
Front Brake Light Switch Screw	1.2	0.12	10 in·lb	
Front Turn Signal Light Lens Screws	1.0	0.10	9 in·lb	
Front Turn Signal Light Mounting Screws	1.2	0.12	10 in·lb	
Headlight Mounting Screws	1.2	0.12	10 in·lb	
Licence Light Assembly Screws	0.9	0.09	8 in·lb	
Licence Light Mounting Screws	1.2	0.12	10 in·lb	
Meter Mounting Screws	1.2	0.12	10 in·lb	
Neutral Switch	15	1.5	11	L
Rear Turn Signal Light Lens Screws	1.0	0.10	9 in·lb	

## 2-14 PERIODIC MAINTENANCE

### Torque and Locking Agent

Fastener	Torque			Remarks
	N·m	kgf·m	ft·lb	
Rear Turn Signal Light Mounting Screws	1.2	0.12	10 in·lb	
Regulator/Rectifier Bolts	6.9	0.70	61 in·lb	
Side Stand Switch Bolt	8.8	0.90	78 in·lb	L
Side Stand Switch Bracket Bolt	3.9	0.40	35 in·lb	L
Spark Plugs	13	1.3	115 in·lb	
Speed Sensor Bolt	12	1.2	104 in·lb	
Stator Coil Bolts	12	1.2	104 in·lb	L
Starter Motor Cable Terminal Bolt	2.7	0.28	24 in·lb	
Starter Motor Clutch Bolts	34	3.5	25	L
Starter Motor Mounting Bolts	11	1.1	97 in·lb	
Starter Relay Cable Terminal Bolts	3.9	0.40	35 in·lb	
Switch Housing Screws	3.5	0.36	31 in·lb	
Tail/Brake Light Mounting Screws	4.0	0.40	35 in·lb	
Timing Rotor Bolt	45	4.5	33	
Vehicle-down Sensor Bolts	5.9	0.60	52 in·lb	
Water Temperature Sensor	25	2.5	18	SS

The table below, relating tightening torque to thread diameter, lists the basic torque for the bolts and nuts. Use this table for only the bolts and nuts which do not require a specific torque value. All of the values are for use with dry solvent-cleaned threads.

### Basic Torque for General Fasteners

Threads Diameter (mm)	Torque		
	N·m	kgf·m	ft·lb
5	3.4 ~ 4.9	0.35 ~ 0.50	30 ~ 43 in·lb
6	5.9 ~ 7.8	0.60 ~ 0.80	52 ~ 69 in·lb
8	14 ~ 19	1.4 ~ 1.9	10 ~ 13.5
10	25 ~ 34	2.6 ~ 3.5	19 ~ 25
12	44 ~ 61	4.5 ~ 6.2	33 ~ 45
14	73 ~ 98	7.4 ~ 10.0	54 ~ 72
16	115 ~ 155	11.5 ~ 16.0	83 ~ 115
18	165 ~ 225	17.0 ~ 23.0	125 ~ 165
20	225 ~ 325	23.0 ~ 33.0	165 ~ 240

**Specifications**

Item	Standard	Service Limit
<b>Fuel System</b>		
Throttle Grip Free Play	2 ~ 3 mm (0.08 ~ 0.12 in.)	---
Idle Speed	1 300 ±50 r/min (rpm)	---
Throttle Body Vacuum	27.3 ±1.3 kPa (205 ±10 mmHg) at idle speed	---
Air Cleaner Element	Viscous paper element	---
<b>Cooling System</b>		
Coolant:		
Type (Recommended)	Permanent type antifreeze	---
Color	Green	---
Mixed Ratio	Soft water 50%, coolant 50%	---
Freezing Point	-35°C (-31°F)	---
Total Amount	2.6 L (2.7 US qt)	---
<b>Engine Top End</b>		
Valve Clearance:		
Exhaust	0.22 ~ 0.31 mm (0.0087 ~ 0.0122 in.)	---
Inlet	0.11 ~ 0.19 mm (0.0043 ~ 0.0075 in.)	---
<b>Clutch</b>		
Clutch Lever Free Play	2 ~ 3 mm (0.08 ~ 0.12 in.)	---
<b>Engine Lubrication System</b>		
Engine Oil:		
Type	API SE, SF or SG API SH or SJ with JASO MA	---
Viscosity	SAE 10W-40	---
Capacity	3.4 L (3.6 US qt) (when filter is not removed)	---
	3.6 L (3.8 US qt) (when filter is removed)	---
	4.0 L (4.2 US qt) (when engine is completely dry)	---
Level	Between upper and lower level lines (Wait 2 ~ 3 minutes after idling or running)	---
<b>Tires</b>		
Tread Depth:		
Front	BRIDGESTONE: 3.6 mm (0.14 in.)	1 mm (0.04 in.), (AT, CH, DE) 1.6 mm (0.06 in.)
Rear	BRIDGESTONE: 5.8 mm (0.23 in.)	Up to 130 km/h (80 mph): 2 mm (0.08 in.), Over 130 km/h (80 mph): 3 mm (0.12 in.)
Air Pressure (when Cold):		
Front	Up to 180 kg (397 lb) load: 250 kPa (2.5 kgf/cm <sup>2</sup> , 36 psi)	---
Rear	Up to 180 kg (397 lb) load: 290 kPa (2.9 kgf/cm <sup>2</sup> , 42 psi)	---

## 2-16 PERIODIC MAINTENANCE

### Specifications

Item	Standard	Service Limit
<b>Final Drive</b>		
Drive Chain Slack	30 ~ 35 mm (1.2 ~ 1.4 in.)	---
Drive Chain Wear (20-link Length)	317.5 ~ 318.2 mm (12.50 ~ 12.53 in.)	323 mm (12.7 in.)
Standard Chain:		
Make	ENUMA	---
Type	EK520MVXL	---
Link	110 links	---
<b>Brakes</b>		
Brake Fluid:		
Grade	DOT4	---
Brake Pad Lining Thickness:		
Front	4.0 mm (0.16 in.)	1 mm (0.04 in.)
Rear	5.0 mm (0.20 in.)	1 mm (0.04 in.)
Brake Light Timing:		
Front	Pulled ON	---
Rear	On after about 10 mm (0.39 in.) of pedal travel	---
<b>Electrical System</b>		
Spark Plug Gap	0.7 ~ 0.8 mm (0.028 ~ 0.031 in.)	---

AT: Austria

CH: Switzerland

DE: Germany

US: United States

**Special Tools**

**Inside Circlip Pliers:**  
57001-143

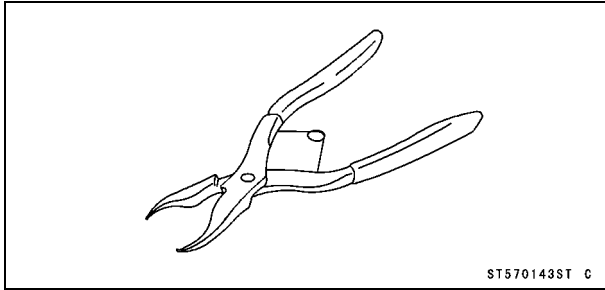

**Pilot Screw Adjuster, C:**  
57001-1292

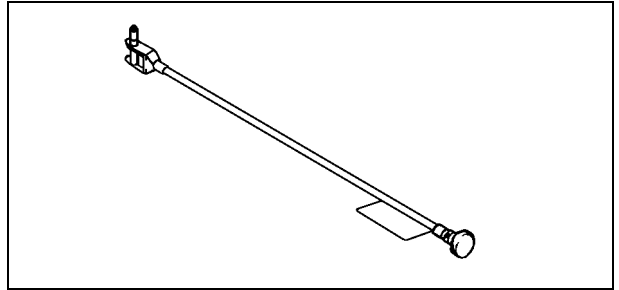

**Steering Stem Nut Wrench:**  
57001-1100

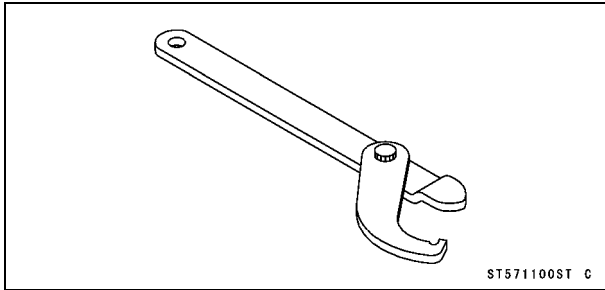

**Extension Tube:**  
57001-1578

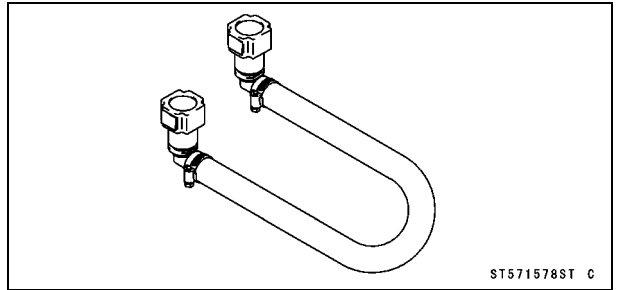

**Jack:**  
57001-1238

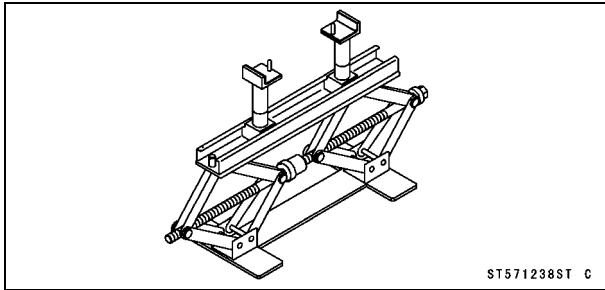

**Jack Attachment:**  
57001-1608

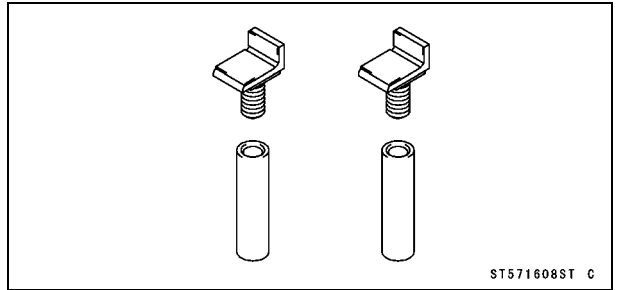

**Oil Filter Wrench:**  
57001-1249

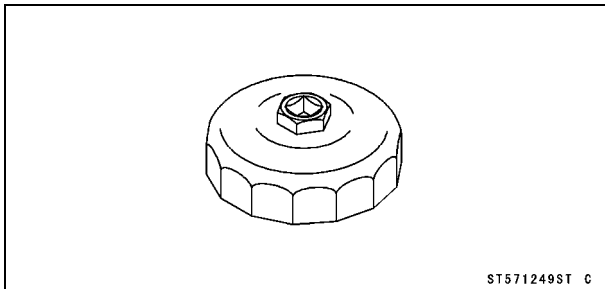

## 2-18 PERIODIC MAINTENANCE

### Maintenance Procedure

#### Fuel System (DFI)

##### Throttle Control System Inspection

- Check the throttle grip free play [A].
- ★ If the free play is incorrect, adjust the throttle cables.

##### Throttle Grip Free Play

Standard: 2 ~ 3 mm (0.08 ~ 0.12 in.)

- Check that the throttle grip [B] moves smoothly from full open to close, and the throttle closes quickly and completely by the return spring in all steering positions.
- ★ If the throttle grip does not return properly, check the throttle cables routing, grip free play, and cable damage. Then lubricate the throttle cable.
- Run the engine at the idle speed, and turn the handlebar all the way to the right and left to ensure that the idle speed does not change.
- ★ If the idle speed increases, check the throttle cable free play and the cable routing.
- ★ If necessary, adjust the throttle cable as follows.
  - Loosen the locknuts [A] [B].
  - Screw both throttle cable adjusters [C] [D] to give the throttle grip plenty of play.
  - Turn the decelerator cable adjuster [C] until 2 ~ 3 mm (0.08 ~ 0.12 in.) of throttle grip play is obtained.
  - Tighten the locknut [A].
  - Turn the accelerator cable adjuster [D] until 2 ~ 3 mm (0.08 ~ 0.12 in.) of throttle grip play is obtained.
  - Tighten the locknut [B].
- ★ If the free play cannot be adjusted with the adjusters, replace the cable.

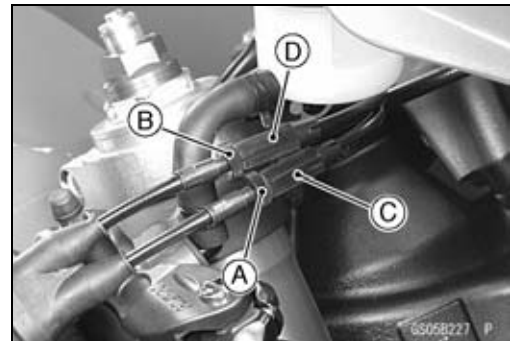
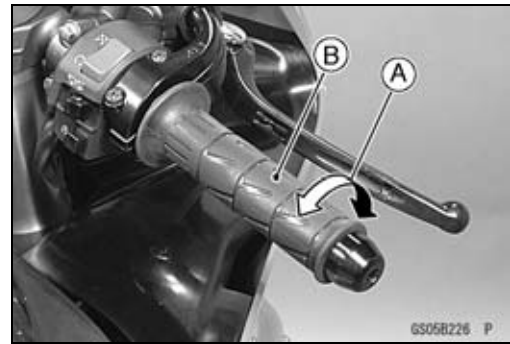

##### Engine Vacuum Synchronization Inspection

##### NOTE

○ These procedures are explained on the assumption that the inlet and exhaust systems of the engine are in good condition.

- Situate the motorcycle so that it is vertical.
- Remove the fuel tank (see Fuel Tank Removal in the Fuel System (DFI) chapter).
- Pull off the vacuum hoses and the rubber cap(s) from the right fitting of each throttle body.
- Pull off the vacuum switch valve hose (thick) [A] from the air cleaner housing [B].

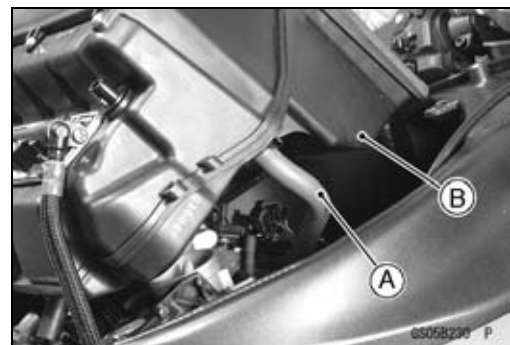

##### CAUTION

**Do not remove the inlet air pressure sensor hoses on the left fitting of each throttle body.**

**Maintenance Procedure**

- Connect a commercially available vacuum gauge [A] to these right fittings of the throttle body as shown.  
Front [B]
- Connect a highly accurate tachometer to one of the stick coil primary leads.
- Plug:  
Vacuum Switch Valve Hose (Thick) and its Air Cleaner Housing Hole  
Vacuum Switch Valve Vacuum Hose Ends [C]

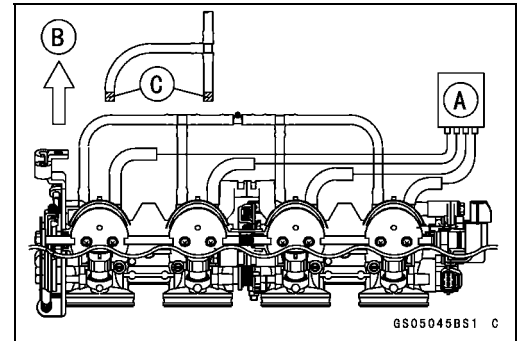

- Install:  
Air Cleaner Housing [A] (see Air Cleaner Housing Removal in the Fuel System (DFI) chapter)  
Tachometer [B]  
Vacuum Gauge [C]
- Connect:  
Extension Tube [D]
- Special Tool - Extension Tube: 57001-1578**
- Start the engine and warm it up thoroughly.
- Check the idle speed.
- Open and close the throttle.
- ★ If the idle speed is out of the specified range, adjust it.

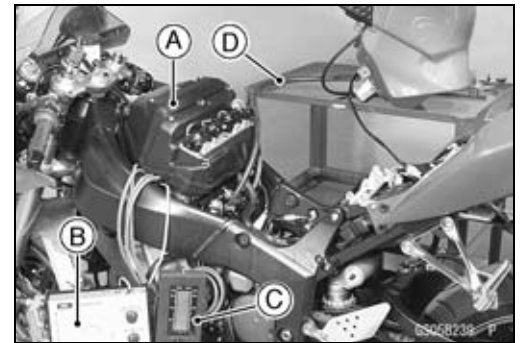

**CAUTION**

**Do not measure the idle speed by the tachometer of the meter unit.**

- While idling the engine, inspect the engine vacuum, using the vacuum gauge [B].

**Engine Vacuum**

**Standard: 27.3 ±1.333 kPa (205 ±10 mmHg) at Idle  
Speed 1 300 ±50 r/min (rpm)**

## 2-20 PERIODIC MAINTENANCE

### Maintenance Procedure

★ If any vacuum is not within the specifications, first synchronize the balance of the left (#1, #2) and right (#3, #4) assemblies.

**Example:**

- #1: 165 mmHg
- #2: 190 mmHg
- #3: 170 mmHg
- #4: 200 mmHg

● With the engine at the correct idle speed, equalize the lower vacuum of #3 and #4 (example 170 mmHg) to the lower vacuum of #1 and #2 (example 165 mmHg) by turning the center adjusting screw [A].

**Special Tool - Pilot Screw Adjuster, C: 57001-1292**

Front [B]

#### NOTE

○ After adjustment, the final vacuum measurement between the lowest throttle valves may not be 165 mmHg (in this example). The goal is to have the lower two vacuums between the left (#1 and #2) and right (#3 and #4) banks be the same.

- Open and close the throttle after each measurement and adjust the idle speed as necessary.
- Once the throttle valves have been synchronized, inspect the main throttle sensor's output voltage to ensure proper operation (procedure is at the end of this section).

★ If any one vacuum measurement is out of the standard measurement after left and right synchronization, turn in the bypass screws [A] until it seats fully but not tightly.  
Front [B]

#### CAUTION

**Do not over tighten them. They could be damaged, requiring replacement.**

- Turn out the bypass screw of the higher vacuum between #1 and #2 to the lower vacuum.
- Turn out the bypass screw of the higher vacuum between #3 and #4 to the lower vacuum.
- Open and close the throttle valves after each measurement and adjust the idle speed as necessary.
- Inspect the vacuums as before.
- ★ If all vacuums are within the specification, finish the engine vacuum synchronization.
- ★ If any vacuum can not be adjusted within the specification, remove the bypass screws #1 ~ #4 and clean them.

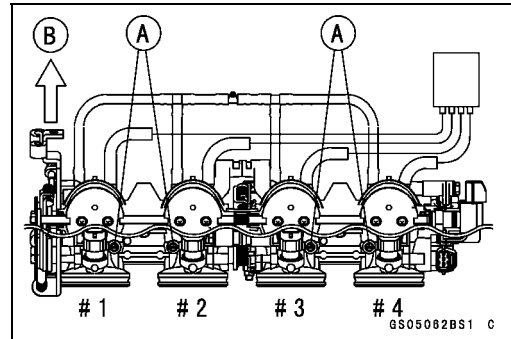
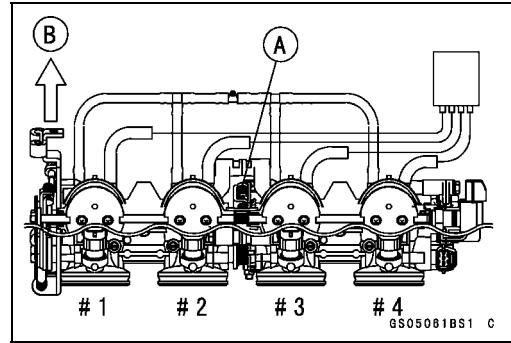

**Maintenance Procedure**

- Remove the bypass screw [A], spring [B], washer [C] and O-ring [D].
- Check the bypass screw and its hole for carbon deposits.
- ★ If any carbon accumulates, wipe the carbon off the bypass screw and the hole, using a cotton pad penetrated with a high-flash point solvent.
- Replace the O-ring with a new one.
- Check the tapered portion [E] of the bypass screw for wear or damage.
- ★ If the bypass screw is worn or damaged, replace it.
- Turn in the bypass screw until it seats fully but not tightly.
  
- Repeat the same procedure for other bypass screws.
- Repeat the synchronization.
- ★ If the vacuums are correct, check the output voltage of the main throttle sensor (see Output Voltage Inspection of the Main Throttle Sensor in the Fuel System (DFI) chapter).

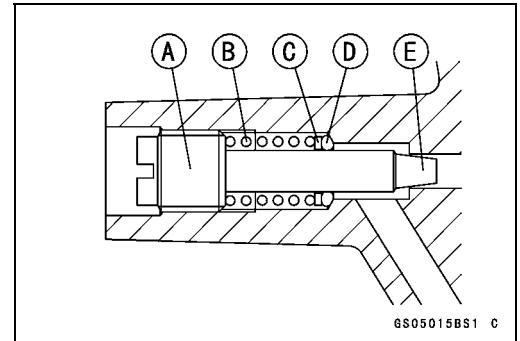

**Main Throttle Sensor Output Voltage**

**Connections to ECU**

- Meter (+) → Y/W lead (terminal 7)
- Meter (-) → BR/BK lead (terminal 28)

**Standard: 1.02 ~ 1.06 V DC (at idle throttle opening)**

- ★ If the output voltage is out of the range, check the throttle input voltage (see Input Voltage Inspection of the Main Throttle Sensor in the Fuel System (DFI) chapter).
- Remove the vacuum gauge hoses and install the vacuum hoses [A] and rubber caps [B] on the original position as shown.
  - Front [C]
  - Except California Model [D]
  - California Model [E]
  - Separator [F]
  - Canister [G]

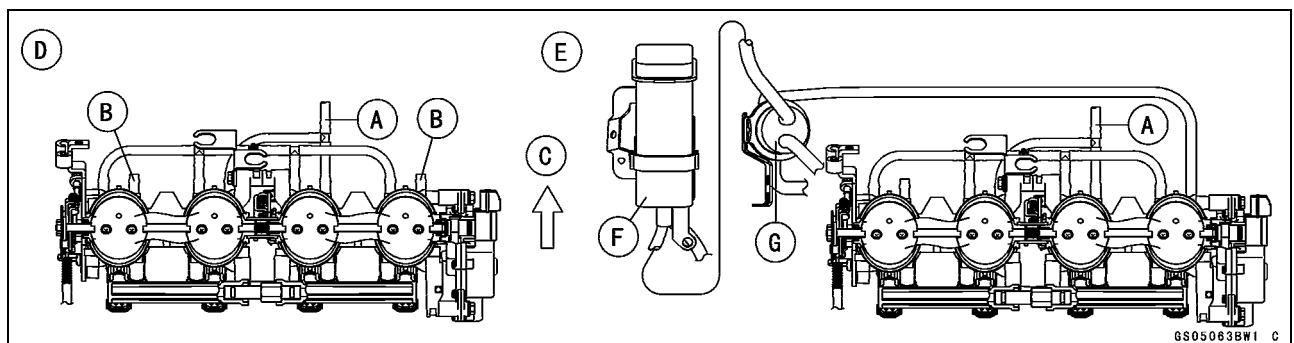

## 2-22 PERIODIC MAINTENANCE

### Maintenance Procedure

#### Idle Speed Inspection

- Start the engine and warm it up thoroughly.
- With the engine idling, turn the handlebar to both sides [A].
- ★ If handlebar movement changes the idle speed, the throttle cables may be improperly adjusted or incorrectly routed, or damaged. Be sure to correct any of these conditions before riding (see Cable, Wire, and Hose Routing section in the Appendix chapter).

#### **⚠ WARNING**

**Operation with improperly adjusted, incorrectly routed, or damaged cables could result in an unsafe riding condition.**

- Check the idle speed.
- ★ If the idle speed is out of specified range, adjust it.

#### Idle Speed

Standard: 1 300 ±50 r/min (rpm)

#### Idle Speed Adjustment

- Start the engine and warm it up thoroughly.
- Turn the adjusting screw [A] until the idle speed is correct.
- Open and close the throttle a few times to make sure that the idle speed is within the specified range. Readjust if necessary.

#### Fuel Hose Damage and Installation Condition Inspection

- The motorcycle is not properly handled, the high pressure inside the fuel line can cause fuel to leak or the hose to burst. Remove the fuel tank (see Fuel Tank Removal in the Fuel System (DFI) chapter) and check the fuel hose [A].
- ★ Replace the fuel hose if any fraying, cracks [B] or bulges [C] are noticed.
- Check that the hose joints are securely connected.
- When installing the fuel hose, avoid sharp bending, kinking, flattening or twisting.
- ★ Replace the hose if it has been sharply bent or kinked.

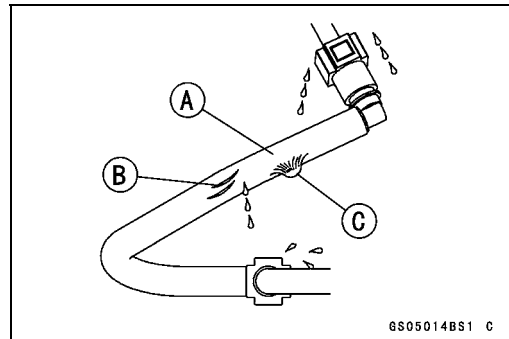
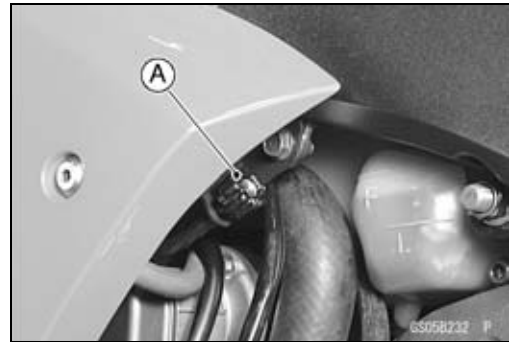
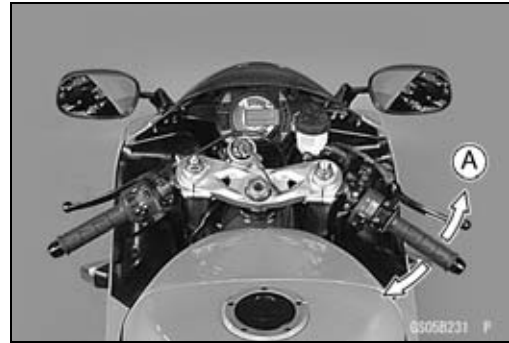

## Maintenance Procedure

### Evaporative Emission Control System (California Model)

#### Evaporative Emission Control System Inspection

- Inspect the canister as follows.
- Remove:
  - Left Upper Inner Fairing (see Upper Inner Fairing Removal in the Frame chapter)
- Remove the canister [A], and disconnect the hoses from the canister.
- Visually inspect the canister for cracks or other damage.
- ★ If the canister has any cracks or bad damage, replace it with a new one.



#### NOTE

- *The canister is designed to work well through the motorcycle's life without any maintenance if it is used under normal conditions.*

- Check the liquid/vapor separator as follows.
- Remove:
  - Left Center Fairing (see Center Fairing Removal in the Frame chapter)
- Disconnect the hoses from the separator, and remove the separator [A] from the motorcycle left side.
- Visually inspect the separator for cracks and other damage.
- ★ If the separator has any cracks or damage, replace it with a new one.
- To prevent the gasoline from flowing into or out of the canister, hold the separator perpendicular to the ground.
- Check the hoses of the evaporative emission control system as follows.
- Check that the hoses are securely connected and clips are in position.
- Replace any kinked, deteriorated or damaged hoses.
- Route the hoses according to Cable, Wire, and Hose Routing section in the Appendix chapter.
- When installing the hoses, avoid sharp bending, kinking, flattening or twisting, and route the hoses with a minimum of bending so that the emission flow will not be obstructed.

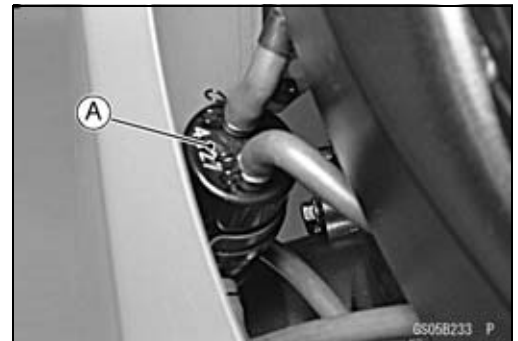

## 2-24 PERIODIC MAINTENANCE

### Maintenance Procedure

#### Cooling System

##### Coolant Level Inspection

#### NOTE

○ Check the level when the engine is cold (room or ambient temperature).

- Check the coolant level in the reserve tank [A] with the motorcycle held perpendicular (Do not use the side stand).

★ If the coolant level is lower than the "L" level line [B], unscrew the reserve tank cap and add coolant to the "F" level line [C].

"L": low

"F": full

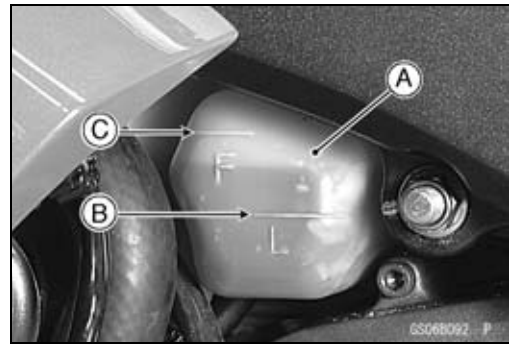

#### CAUTION

For refilling, add the specified mixture of coolant and soft water. Adding water alone dilutes the coolant and degrades its anticorrosion properties. The diluted coolant can attack the aluminum engine parts. In an emergency, soft water alone can be added. But the diluted coolant must be returned to the correct mixture ratio within a few days.

If coolant must be added often or the reservoir tank has run completely dry, there is probably leakage in the cooling system. Check the system for leaks.

Coolant ruins painted surfaces. Immediately wash away any coolant that spills on the frame, engine, wheels or other painted parts.

##### Radiator Hose Damage and Installation Condition Inspection

○ The high pressure inside the radiator hose can cause coolant to leak [A] or the hose to burst if the line is not properly maintained. Visually inspect the hoses for signs of deterioration. Squeeze the hoses. A hose should not be hard and brittle, nor should it be soft or swollen.

★ Replace the hose if any fraying, cracks [B] or bulges [C] are noticed.

● Check that the hoses are securely connected and clamps are tightened correctly.

**Torque - Radiator Hose Clamp Screws: 2.0 N·m (0.20 kgf·m, 17 in·lb)**

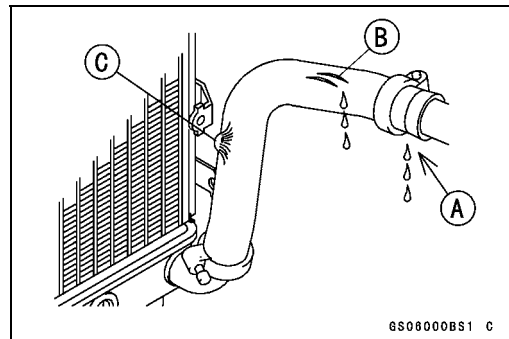

**Maintenance Procedure**

**Engine Top End**

*Valve Clearance Inspection*

**NOTE**

○ *Valve clearance must be checked and adjusted when the engine is cold (at room temperature).*

- Remove:
  - Lower Fairings (see Lower Fairing Removal in the Frame chapter)
  - Crankshaft Sensor Cover (see Crankshaft Sensor Removal in the Electrical System chapter)
  - Cylinder Head Cover (see Cylinder Head Cover Removal in the Engine Top End chapter)
- Position the crankshaft at #1, 4 piston TDC.
  - TDC Mark [A] for #1, 4 Pistons
  - Timing Mark [B] (Crankcase Halves Mating Surface)

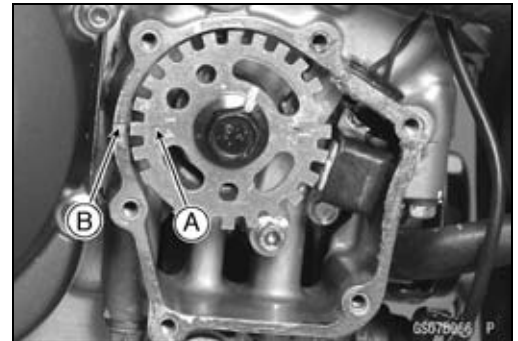

- Using a thickness gauge [A], measure the valve clearance between the cam and the valve lifter.

**Valve Clearance**

**Standard:**

**Exhaust** 0.22 ~ 0.31 mm (0.0087 ~ 0.0122 in.)

**Inlet** 0.11 ~ 0.19 mm (0.0043 ~ 0.0075 in.)

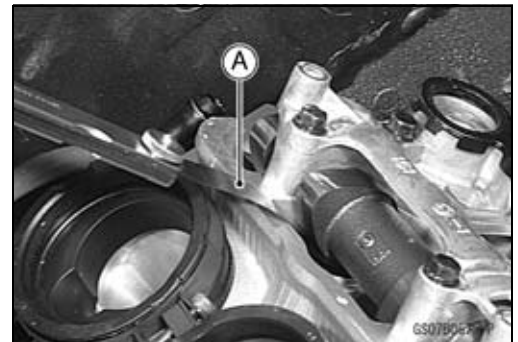

**NOTE**

○ *Thickness gauge is horizontally inserted on the valve lifter.*

- Appropriateness [A]
- Inadequacy [B]
- Thickness Gauge [C]
- Horizontally Inserts [D]
- Cam [E]
- Valve Lifter [F]
- Hits the Valve Lifter Ahead [G]

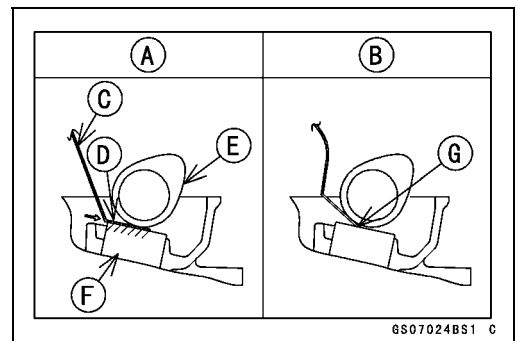

## 2-26 PERIODIC MAINTENANCE

### Maintenance Procedure

- When positioning #1 piston TDC at the end of the compression stroke.

Inlet Valve Clearance of #1 and #3 Cylinders  
Exhaust Valve Clearance of #1 and #2 Cylinders  
Measuring Valve [A]

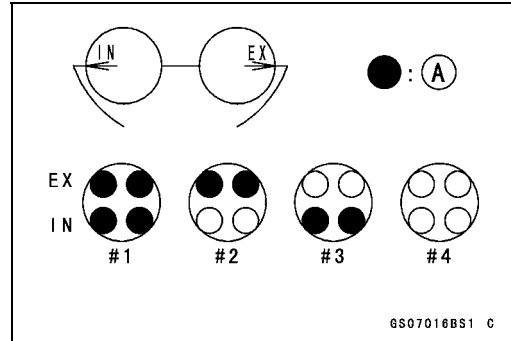

- When positioning #4 piston TDC at the end of the compression stroke.

Inlet Valve Clearance of #2 and #4 Cylinders  
Exhaust Valve Clearance of #3 and #4 Cylinders  
Measuring Valve [A]

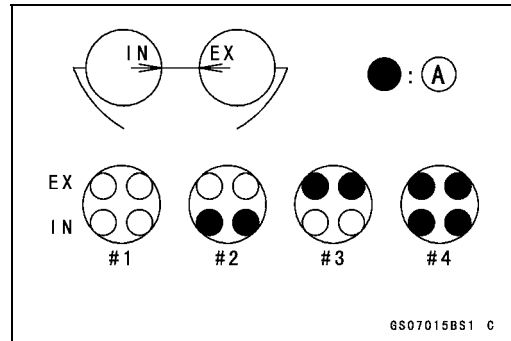

- ★If the valve clearance is not within the specified range, first record the clearance, and then adjust it.

#### Valve Clearance Adjustment

- To change the valve clearance, remove the camshaft chain tensioner, camshafts and valve lifters (see appropriate chapters). Replace the shim with one of a different thickness.

#### NOTE

- Mark and record the valve lifter and shim locations so they can be reinstalled in their original positions.
- If there is no clearance, select a shim which is several sizes smaller and then measure the clearance.
- To select a new shim which brings the valve clearance within the specified range, refer to the Valve Clearance Adjustment Charts.
- Apply a thin coat of engine oil to the valve lifter surface and install the lifter.
- Install the camshafts. Be sure to time the camshafts properly (see Camshaft Installation in the Engine Top End chapter).
- Remeasure any valve clearance that was adjusted. Readjust if necessary.

#### CAUTION

**Do not put shim stock under the shim. This may cause the shim to pop out at high rpm, causing extensive engine damage. Do not grind the shim. This may cause it to fracture, causing extensive engine damage.**

Maintenance Procedure

VALVE CLEARANCE ADJUSTMENT CHART INLET VALVE

		PRESENT SHIM																			Example				
PART No. (92180-)		1014	1016	1018	1020	1022	1024	1026	1028	1030	1032	1034	1036	1038	1040	1042	1044	1046	1048	1050	1052	1054			
MARK		50	55	60	65	70	75	80	85	90	95	00	05	10	15	20	25	30	35	40	45	50			
THICKNESS (mm)		2.50	2.55	2.60	2.65	2.70	2.75	2.80	2.85	2.90	2.95	3.00	3.05	3.10	3.15	3.20	3.25	3.30	3.35	3.40	3.45	3.50			
VALVE CLEARANCE MEASUREMENT	Example	0.00~0.05	-	-	2.50	2.55	2.60	2.65	2.70	2.75	2.80	2.85	2.90	2.95	3.00	3.05	3.10	3.15	3.20	3.25	3.30	3.35	3.40		
		0.06~0.10	-	2.50	2.55	2.60	2.65	2.70	2.75	2.80	2.85	2.90	2.95	3.00	3.05	3.10	3.15	3.20	3.25	3.30	3.35	3.40	3.45		
		0.11~0.19	SPECIFIED CLEARANCE/NO CHANGE REQUIRED																						
		0.20~0.24	2.55	2.60	2.65	2.70	2.75	2.80	2.85	2.90	2.95	3.00	3.05	3.10	3.15	3.20	3.25	3.30	3.35	3.40	3.45	3.50			
		0.25~0.29	2.60	2.65	2.70	2.75	2.80	2.85	2.90	2.95	3.00	3.05	3.10	3.15	3.20	3.25	3.30	3.35	3.40	3.45	3.50				
		0.30~0.34	2.65	2.70	2.75	2.80	2.85	2.90	2.95	3.00	3.05	3.10	3.15	3.20	3.25	3.30	3.35	3.40	3.45	3.50					
		0.35~0.39	2.70	2.75	2.80	2.85	2.90	2.95	3.00	3.05	3.10	3.15	3.20	3.25	3.30	3.35	3.40	3.45	3.50						
		0.40~0.44	2.75	2.80	2.85	2.90	2.95	3.00	3.05	3.10	3.15	3.20	3.25	3.30	3.35	3.40	3.45	3.50							
		0.45~0.49	2.80	2.85	2.90	2.95	3.00	3.05	3.10	3.15	3.20	3.25	3.30	3.35	3.40	3.45	3.50								
		0.50~0.54	2.85	2.90	2.95	3.00	3.05	3.10	3.15	3.20	3.25	3.30	3.35	3.40	3.45	3.50									
		0.55~0.59	2.90	2.95	3.00	3.05	3.10	3.15	3.20	3.25	3.30	3.35	3.40	3.45	3.50										
		0.60~0.64	2.95	3.00	3.05	3.10	3.15	3.20	3.25	3.30	3.35	3.40	3.45	3.50											
		0.65~0.69	3.00	3.05	3.10	3.15	3.20	3.25	3.30	3.35	3.40	3.45	3.50												
		0.70~0.74	3.05	3.10	3.15	3.20	3.25	3.30	3.35	3.40	3.45	3.50													
		0.75~0.79	3.10	3.15	3.20	3.25	3.30	3.35	3.40	3.45	3.50														
		0.80~0.84	3.15	3.20	3.25	3.30	3.35	3.40	3.45	3.50															
		0.85~0.89	3.20	3.25	3.30	3.35	3.40	3.45	3.50																
	0.90~0.94	3.25	3.30	3.35	3.40	3.45	3.50																		
	0.95~0.99	3.30	3.35	3.40	3.45	3.50																			
	1.00~1.04	3.35	3.40	3.45	3.50																				
	1.05~1.09	3.40	3.45	3.50																					
	1.10~1.14	3.45	3.50																						
	1.15~1.19	3.50																							

INSTALL THE SHIM OF THIS THICKNESS (mm)

6S07027B\*3 C

1. Measure the clearance (when engine is cold).
2. Check present shim size.
3. Match clearance in vertical column with present shim size in horizontal column.
4. Install the shim specified where the lines intersect. This shim will give the proper clearance.

**Example:**

Present shim is **3.05 mm**.  
 Measured clearance is **0.35 mm**.  
 Replace **3.05 mm** shim with **3.25 mm** shim.

5. Remeasure the valve clearance and readjust if necessary.

# 2-28 PERIODIC MAINTENANCE

## Maintenance Procedure

### VALVE CLEARANCE ADJUSTMENT CHART EXHAUST VALVE

		PRESENT SHIM																			Example					
PART No. (92180-)	1014	1016	1018	1020	1022	1024	1026	1028	1030	1032	1034	1036	1038	1040	1042	1044	1046	1048	1050	1052	1054					
MARK	50	55	60	65	70	75	80	85	90	95	00	05	10	15	20	25	30	35	40	45	50					
THICKNESS (mm)	2.50	2.55	2.60	2.65	2.70	2.75	2.80	2.85	2.90	2.95	3.00	3.05	3.10	3.15	3.20	3.25	3.30	3.35	3.40	3.45	3.50					
Example	0.00~0.02	-	-	-	-	2.50	2.55	2.60	2.65	2.70	2.75	2.80	2.85	2.90	2.95	3.00	3.05	3.10	3.15	3.20	3.25					
	0.03~0.06	-	-	-	-	2.50	2.55	2.60	2.65	2.70	2.75	2.80	2.85	2.90	2.95	3.00	3.05	3.10	3.15	3.20	3.25	3.30				
	0.07~0.11	-	-	-	2.50	2.55	2.60	2.65	2.70	2.75	2.80	2.85	2.90	2.95	3.00	3.05	3.10	3.15	3.20	3.25	3.30	3.35				
	0.12~0.16	-	-	2.50	2.55	2.60	2.65	2.70	2.75	2.80	2.85	2.90	2.95	3.00	3.05	3.10	3.15	3.20	3.25	3.30	3.35	3.40				
	0.17~0.21	-	2.50	2.55	2.60	2.65	2.70	2.75	2.80	2.85	2.90	2.95	3.00	3.05	3.10	3.15	3.20	3.25	3.30	3.35	3.40	3.45				
	0.22~0.31	SPECIFIED CLEARANCE/NO CHANGE REQUIRED																								
	0.32~0.36	2.55	2.60	2.65	2.70	2.75	2.80	2.85	2.90	2.95	3.00	3.05	3.10	3.15	3.20	3.25	3.30	3.35	3.40	3.45	3.50					
	0.37~0.41	2.60	2.65	2.70	2.75	2.80	2.85	2.90	2.95	3.00	3.05	3.10	3.15	3.20	3.25	3.30	3.35	3.40	3.45	3.50						
	0.42~0.46	2.65	2.70	2.75	2.80	2.85	2.90	2.95	3.00	3.05	3.10	3.15	3.20	3.25	3.30	3.35	3.40	3.45	3.50							
	0.47~0.51	2.70	2.75	2.80	2.85	2.90	2.95	3.00	3.05	3.10	3.15	3.20	3.25	3.30	3.35	3.40	3.45	3.50								
	0.52~0.56	2.75	2.80	2.85	2.90	2.95	3.00	3.05	3.10	3.15	3.20	3.25	3.30	3.35	3.40	3.45	3.50									
	0.57~0.61	2.80	2.85	2.90	2.95	3.00	3.05	3.10	3.15	3.20	3.25	3.30	3.35	3.40	3.45	3.50										
	0.62~0.66	2.85	2.90	2.95	3.00	3.05	3.10	3.15	3.20	3.25	3.30	3.35	3.40	3.45	3.50											
	0.67~0.71	2.90	2.95	3.00	3.05	3.10	3.15	3.20	3.25	3.30	3.35	3.40	3.45	3.50												
	0.72~0.76	2.95	3.00	3.05	3.10	3.15	3.20	3.25	3.30	3.35	3.40	3.45	3.50													
	0.77~0.81	3.00	3.05	3.10	3.15	3.20	3.25	3.30	3.35	3.40	3.45	3.50														
0.82~0.86	3.05	3.10	3.15	3.20	3.25	3.30	3.35	3.40	3.45	3.50																
0.87~0.91	3.10	3.15	3.20	3.25	3.30	3.35	3.40	3.45	3.50																	
0.92~0.96	3.15	3.20	3.25	3.30	3.35	3.40	3.45	3.50																		
0.97~1.01	3.20	3.25	3.30	3.35	3.40	3.45	3.50																			
1.02~1.06	3.25	3.30	3.35	3.40	3.45	3.50																				
1.07~1.11	3.30	3.35	3.40	3.45	3.50																					
1.12~1.16	3.35	3.40	3.45	3.50																						
1.17~1.21	3.40	3.45	3.50																							
1.22~1.26	3.45	3.50																								
1.27~1.31	3.50																									

INSTALL THE SHIM OF THIS THICKNESS (mm)

6S07060B03 C

1. Measure the clearance (when engine is cold).
2. Check present shim size.
3. Match clearance in vertical column with present shim size in horizontal column.
4. Install the shim specified where the lines intersect. This shim will give the proper clearance.

**Example:**

Present shim is **3.10 mm**.  
 Measured clearance is **0.40 mm**.  
 Replace **3.10 mm** shim with **3.20 mm** shim.

5. Remeasure the valve clearance and readjust if necessary.

## Maintenance Procedure

### Air Suction System

#### Air Suction System Damage Inspection

- Pull the vacuum switch valve hose [A] out of the air cleaner.
- Start the engine and run it at idle speed.
- Plug the vacuum switch valve hose end with your finger and feel vacuum pulsing in the hose.
- ★ If there is no vacuum pulsation, check the hose line for leak. If there is no leak, check the vacuum switch valve or air suction valve (see Vacuum Switch Valve Test, Air Suction Valve Inspection in the Engine Top End chapter).

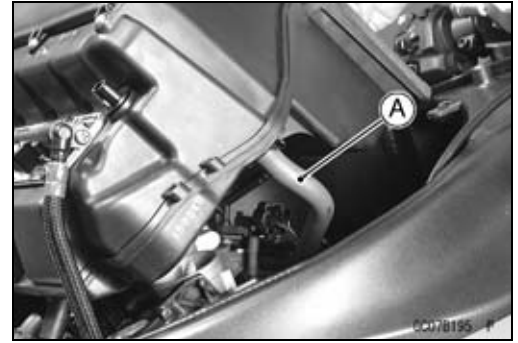

### Clutch

#### Clutch Operation Inspection

- Pull the clutch lever just enough to take up the free play [A].
- Measure the gap between the lever and the lever holder.
- ★ If the gap is too wide, the clutch may not release fully. If the gap is too narrow, the clutch may not engage fully. In either case, adjust it.

#### Clutch Lever Free Play

Standard: 2 ~ 3 mm (0.08 ~ 0.12 in.)



### **⚠ WARNING**

**To avoid a serious burn, never touch the engine or exhaust pipe during clutch adjustment.**

- Turn the adjuster [A] so that 4 ~ 6 mm (0.16 ~ 0.24 in.) [B] of threads is visible.

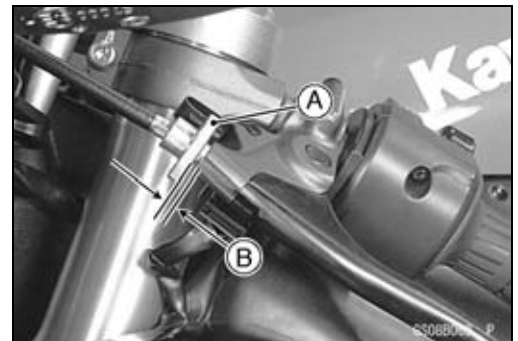

- Remove the right center fairing (see Center Fairing Removal in the Frame chapter).
- Slide the dust cover [A] at the clutch cable lower end out of place.
- Loosen both adjusting nuts [B] at the clutch cover as far as they will go.
- Pull the clutch outer cable [C] tight and tighten the adjusting nuts against the bracket [D].
- Slip the rubber dust cover back onto place.
- Turn the adjuster at the clutch lever until the free play is correct.

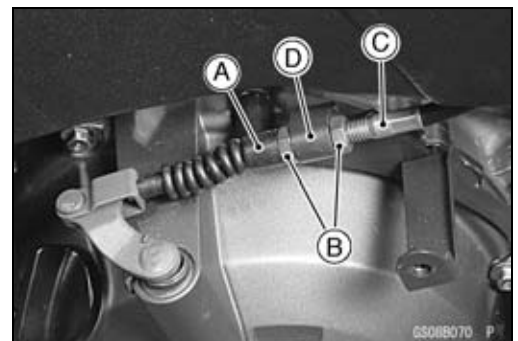

## 2-30 PERIODIC MAINTENANCE

### Maintenance Procedure

- Push the release lever [A] toward the front of the motorcycle until it becomes hard to turn.
- At this time, the release lever should have the proper angle shown.  
60° [B]
- ★ If the angle is wrong, check the clutch and release parts for wear.

#### **⚠ WARNING**

**Be sure that the outer cable end at the clutch lever is fully seated in the adjuster at the clutch lever, or it could slip into place later, creating enough cable play to prevent clutch disengagement.**

- After the adjustment, start the engine and check that the clutch does not slip and that it releases properly.

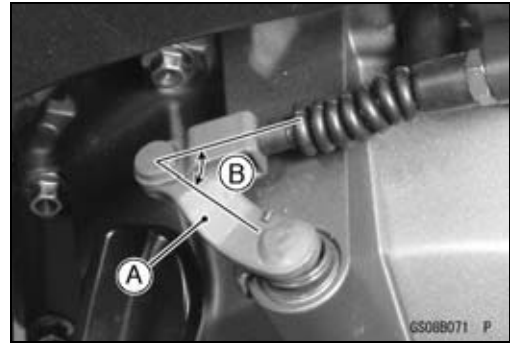

### Wheels/Tires

#### *Air Pressure Inspection*

- Measure the tire air pressure with an air pressure gauge [A] when the tires are cold (that is, when the motorcycle has not been ridden more than a mile during the past 3 hours).
- Install the air valve cap.
- ★ Adjust the tire air pressure according to the specifications if necessary.

#### **Air Pressure (when Cold)**

- Front: Up to 180 kg (397 lb)  
250 kPa (2.5 kgf/cm<sup>2</sup>, 36 psi)**
- Rear: Up to 180 kg (397 lb)  
290 kPa (2.9 kgf/cm<sup>2</sup>, 42 psi)**

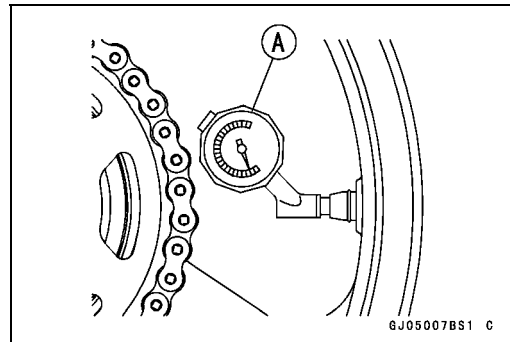

#### *Wheel/Tire Damage Inspection*

- Remove any imbedded stones [A] or other foreign particles [B] from tread.
- Visually inspect the tire for cracks and cuts, and replace the tire if necessary. Swelling or high spots indicate internal damage, requiring tire replacement.
- Visually inspect the wheel for cracks, cuts and dents damage.
- ★ If any damage is found, replace the wheel if necessary.

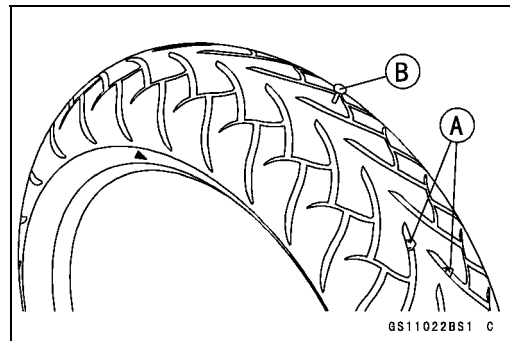

#### *Tire Tread Wear Inspection*

As the tire tread wears down, the tire becomes more susceptible to puncture and failure. An accepted estimate is that 90% of all tire failures occur during the last 10% of tread life (90% worn). So it is false economy and unsafe to use the tires until they are bald.

- Measure the tread depth at the center of the tread with a depth gauge [A]. Since the tire may wear unevenly, take measurement at several places.
- ★ If any measurement is less than the service limit, replace the tire (see Tire Removal/Installation in the Wheels/Tires chapter).

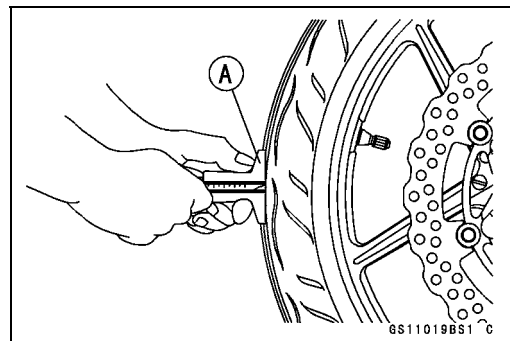

**Maintenance Procedure**

**Tread Depth**

**Standard:**

Front 3.6 mm (0.14 in.)

Rear 5.8 mm (0.23 in.)

**Service Limit:**

Front 1 mm (0.04 in.)

(AT, CH, DE) 1.6 mm (0.06 in.)

Rear 2 mm (0.08 in.) (Up to 130 km/h)

3 mm (0.12 in.) (Over 130 km/h)

**⚠ WARNING**

To ensure safe handling and stability, use only the recommended standard tires for replacement, inflated to the standard pressure.

**NOTE**

○Most countries may have their own regulations a minimum tire tread depth: be sure to follow them.

○Check and balance the wheel when a tire is replaced with a new one.

**Wheel Bearing Damage Inspection**

- Using a jack and attachment, raise the front wheel off the ground (see Front Wheel Removal in the Wheels/Tires chapter).
  - Turn the handlebar all the way to the right or left.
  - Inspect the roughness of the front wheel bearing by pushing and pulling [A] the wheel.
  - Spin [B] the front wheel lightly, and check for smoothly turn, roughness, binding or noise.
  - ★ If roughness, binding or noise is found, remove the front wheel and inspect the wheel bearing (see Front Wheel Removal, Hub Bearing Inspection in the Wheels/Tires chapter).
- 
- Using a stand, raise the rear wheel off the ground (see Rear Wheel Removal in the Wheels/Tires chapter).
  - Inspect the roughness of the rear wheel bearing by pushing and pulling [A] the wheel.
  - Spin [B] the rear wheel lightly, and check for smoothly turn, roughness, binding or noise.
  - ★ If roughness, binding or noise is found, remove the rear wheel and inspect the wheel bearing (see Rear Wheel Removal, Hub Bearing Inspection in the Wheels/Tires chapter) and coupling (see Coupling Bearing Inspection in the Final Drive chapter).

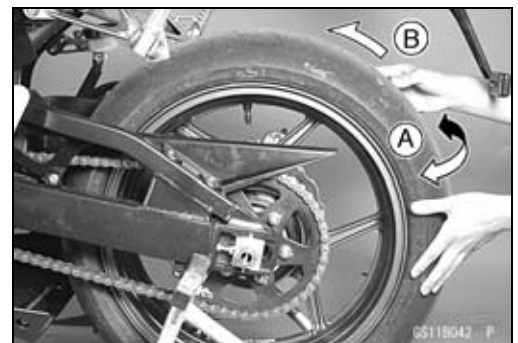
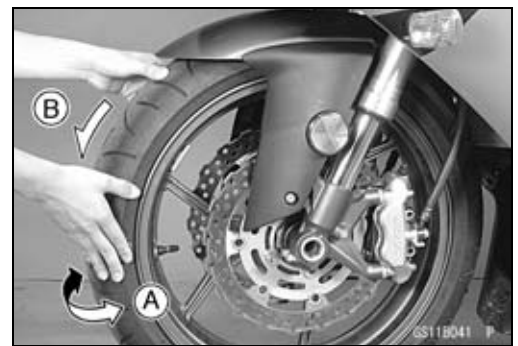

## 2-32 PERIODIC MAINTENANCE

### Maintenance Procedure

#### Drive Train

##### Drive Chain Lubrication Condition Inspection

- If a special lubricant is not available, a heavy oil such as SAE 90 is preferred to a lighter oil because it will stay on the chain longer and provide better lubrication.
- If the chain appears especially dirty, clean it before lubrication.

#### CAUTION

The O-rings between the side plates seal in the lubricant between the pin and the bushing. To avoid damaging the O-rings and resultant loss of lubricant, observe the following rules.

Use only kerosene or diesel oil for cleaning of the O-ring of the drive chain.

Any other cleaning solution such as gasoline or trichloroethylene will cause deterioration and swelling of the O-ring.

Immediately blow the chain dry with compressed air after cleaning.

Complete cleaning and drying the chain within 10 minutes.

- Apply oil to the sides of the rollers so that oil will penetrate to the rollers and bushings. Apply the oil to the O-rings so that the O-rings will be coated with oil.
- Wipe off any excess oil.
  - Oil Applied Areas [A]
  - O-ring [B]

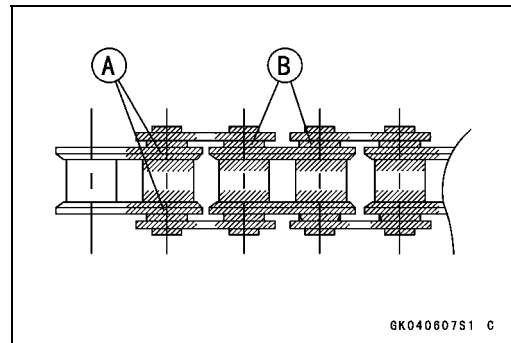

##### Drive Chain Slack Inspection

#### NOTE

- Check the slack with the motorcycle setting on its side stand.
- Clean the chain if it is dirty, and lubricate it if it appears dry.
- Check the wheel alignment (see Wheel Alignment Inspection in this chapter).
- Rotate the rear wheel to find the position where the chain is tightest.
- Measure the vertical movement (chain slack) [A] midway between the sprockets.
- ★ If the chain slack exceeds the standard, adjust it.

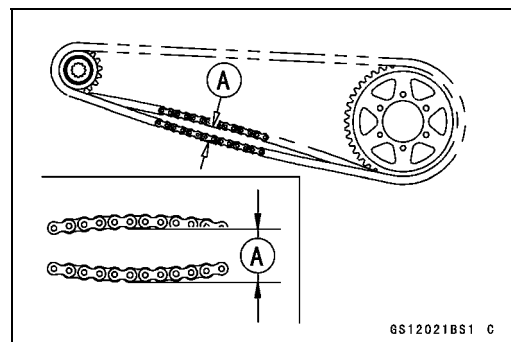

#### Chain Slack

Standard: 30 ~ 35 mm (1.2 ~ 1.4 in.)

**Maintenance Procedure**

*Drive Chain Slack Adjustment*

- Remove the cotter pin [A], and loosen the axle nut [B].
- Loosen the both chain adjuster locknuts [C].
- ★ If the chain is too loose, turn out the left and right chain adjuster [D] evenly.
- ★ If the chain is too tight, turn in the left and right chain adjusters evenly, and kick the wheel forward.
- Turn both chain adjusters evenly until the drive chain has the correct amount of slack. To keep the chain and wheel properly aligned, the notch [E] on the left wheel alignment indicator [F] should align with the same swingarm mark or position [G] that the right indicator notch aligns with.

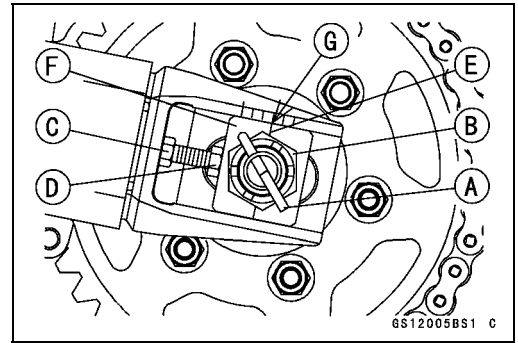

**⚠ WARNING**

**Misalignment of the wheel will result in abnormal wear and may result in an unsafe riding condition.**

- Tighten both chain adjuster locknuts securely.
- Tighten the axle nut.
- Torque - Rear Axle Nut: 127 N·m (13 kgf·m, 94 ft·lb)**
- Turn the wheel, measure the chain slack again at the tightest position, and readjust if necessary.
- Insert a new cotter pin into the axle and bend its end securely.

- Insert a new cotter pin [A].

**NOTE**

- When inserting the cotter pin, if the slots in the nut do not align with the cotter pin hole in the axle, tighten the nut clockwise [B] up to next alignment.
- It should be within 30 degree.
- Loosen once and tighten again when the slot goes past the nearest hole.

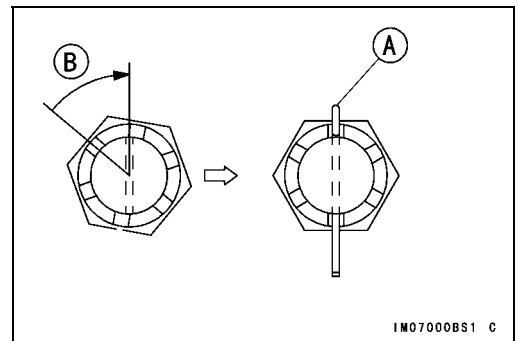

- Bend the cotter pin [A] over the nut.

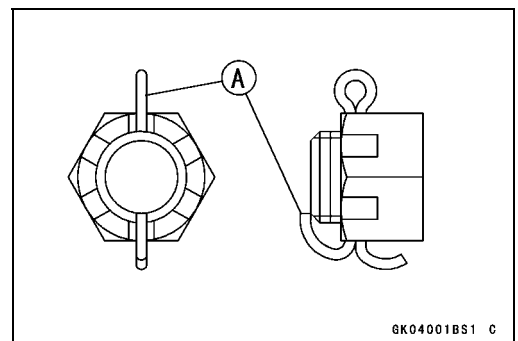

## 2-34 PERIODIC MAINTENANCE

### Maintenance Procedure

#### Wheel Alignment Inspection

- Check that the notch [A] on the left alignment indicator [B] aligns with the same swingarm mark or position [C] that the right alignment indicator notch aligns with.
- ★ If they do not, adjust the chain slack and align the wheel alignment (see Drive Chain Slack Adjustment in this chapter).

#### NOTE

○ Wheel alignment can be also checked using the straightedge or string method.

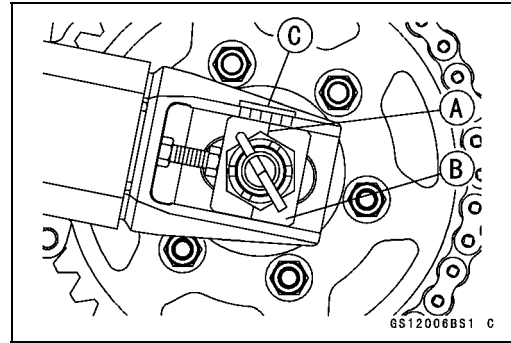

#### ⚠ WARNING

Misalignment of the wheel will result in abnormal wear, and may result in an unsafe riding condition.

#### Drive Chain Wear Inspection

- Remove:  
Chain Cover (see Drive Chain Removal in the Final Drive chapter)
- Rotate the rear wheel to inspect the drive chain for damaged rollers, and loose pins and links.
- ★ If there is any irregularity, replace the drive chain.
- ★ Lubricate the drive chain if it appears dry.
- Stretch the chain taut by hanging a 98 N (10 kg, 20 lb) weight [A] on the chain.
- Measure the length of 20 links [B] on the straight part [C] of the chain from the pin center of the 1st pin to the pin center of the 21st pin. Since the chain may wear unevenly, take measurements at several places.
- ★ If any measurements exceed the service limit, replace the chain. Also, replace the front and rear sprockets when the drive chain is replaced.

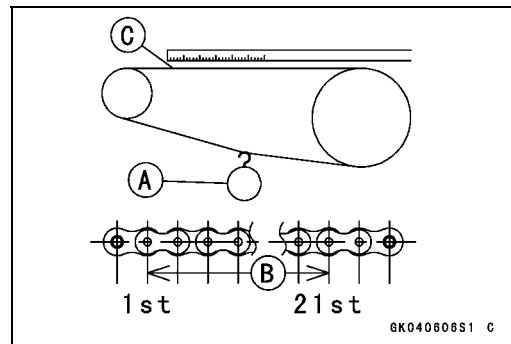

#### Drive Chain 20-link Length

Standard: 317.5 ~ 318.2 mm (12.50 ~ 12.53 in.)

Service Limit: 323 mm (12.7 in.)

#### ⚠ WARNING

If the drive chain wear exceeds the service limit, replace the chain or an unsafe riding condition may result. A chain that breaks or jumps off the sprockets could snag on the engine sprocket or lock the rear wheel, severely damaging the motorcycle and causing it to go out of control.

For safety, use only the standard chain. It is an endless type and should not be cut for installation.

#### Standard Chain

Make: ENUMA

Type: EK520MVXL

Link: 110 links

## Maintenance Procedure

### Chain Guide Wear Inspection

- Remove:
  - Swingarm (see Swingarm Removal in the Suspension chapter)
- Visually inspect the chain guide [A].
- ★ Replace the chain guide if it shows any signs of abnormal wear or damage.



## Brake System

### Brake Fluid Leak (Brake Hose and Pipe) Inspection

- Apply the brake lever or pedal and inspect the brake fluid leak from the brake hoses [A] and fittings.
- ★ If the brake fluid leaked from any position, inspect or replace the problem part.



### Brake Hose Damage and Installation Condition Inspection

- Inspect the brake hoses and fittings for deterioration, cracks and signs of leakage.
- The high pressure inside the brake line can cause fluid to leak [A] or the hose to burst if the line is not properly maintained. Bend and twist the rubber hose while examining it.
- ★ Replace the hose if any crack [B], bulge [C] or leakage is noticed.
- ★ Tighten any brake hose banjo bolts.

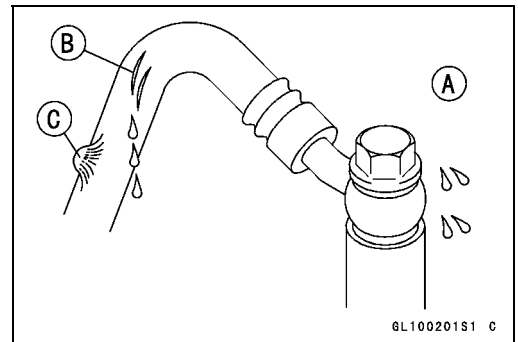

**Torque - Brake Hose Banjo Bolts: 25 N·m (2.5 kgf·m, 18 ft·lb)**

- Inspect the brake hose routing.
- ★ If any brake hose routing is incorrect, route the brake hose according to Cable, Wire, and Hose Routing section in the Appendix chapter.

### Brake Operation Inspection

- Inspect the operation of the front and rear brake by running the vehicle on the dry road.
- ★ If the brake operation is insufficiency, inspect the brake system.

**⚠ WARNING**

**When inspecting by running the vehicle, note a surrounding traffic situation enough in the place of safety.**

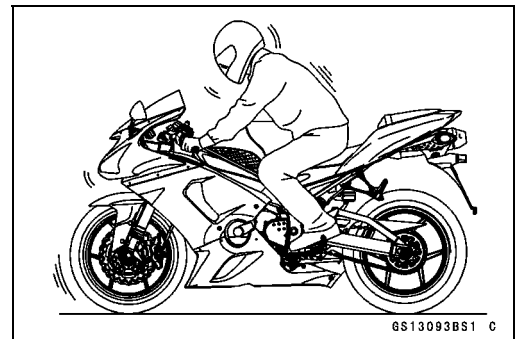

## 2-36 PERIODIC MAINTENANCE

### Maintenance Procedure

#### Brake Fluid Level Inspection

- Check that the brake fluid level in the front brake reservoir [A] is above the lower level line [B].

#### NOTE

○ Hold the reservoir horizontal by turning the handlebar when checking brake fluid level.

- ★ If the fluid level is lower than the lower level line, fill the reservoir to the upper level line [C].

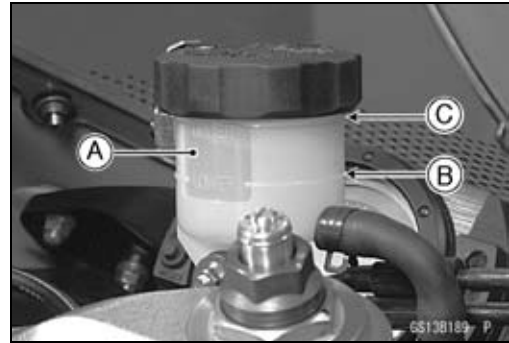

- Check that the brake fluid level in the rear brake reservoir [A] is above the lower level [B].

- ★ If the fluid level is lower than the lower level line, fill the reservoir to the upper level line [C].

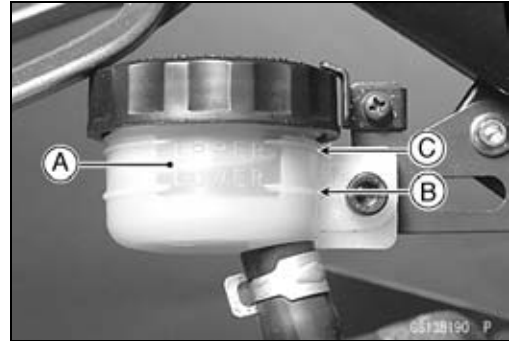

#### ⚠ WARNING

Change the brake fluid in the brake line completely if the brake fluid must be refilled but the type and brand of the brake fluid that is already in the reservoir are unidentified. After changing the fluid, use only the same type and brand of fluid thereafter.

#### Recommended Disc Brake Fluid

Grade: DOT4

#### Brake Pad Wear Inspection

- Remove the brake pads (see Front/Rear Brake Pad Removal in the Brakes chapter).
- Check the lining thickness [A] of the pads in each caliper.
- ★ If the lining thickness of either pad is less than the service limit [B], replace both pads in the caliper as a set.

#### Pad Lining Thickness

Standard:

Front 4.0 mm (0.16 in.)

Rear 5.0 mm (0.20 in.)

Service Limit: 1 mm (0.04 in.)

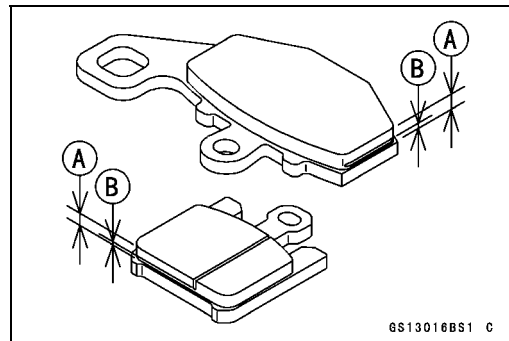

#### Brake Light Switch Operation Inspection

- Turn on the ignition switch.
- The brake light [A] should go on when the brake lever is applied or after the brake pedal is depressed about 10 mm (0.39 in.).

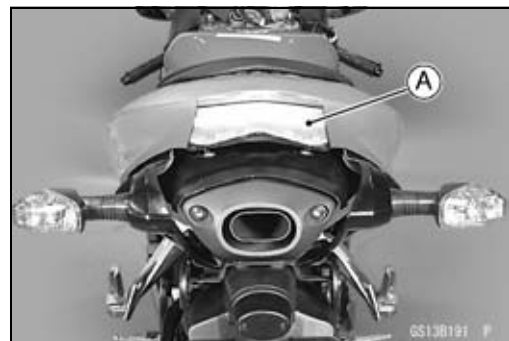

## Maintenance Procedure

- ★ If it does not, adjust the brake light switch.
- While holding the switch body, turn the adjusting nut to adjust the switch.
  - Switch Body [A]
  - Adjusting Nut [B]
  - Light sooner as the body rises [C]
  - Light later as the body lowers [D]

### CAUTION

To avoid damaging the electrical connections inside the switch, be sure that the switch body does not turn during adjustment.

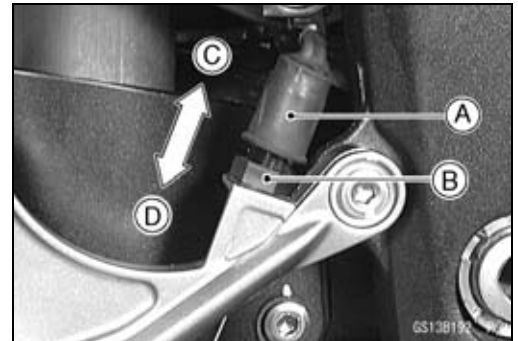

- ★ If it does not go on, inspect or replace the following items.
  - Battery (see Charging Condition Inspection in the Electrical System chapter)
  - Brake Light (see Tail/Brake Light Removal in the Electrical System chapter)
  - Main Fuse 30 A and Taillight Fuse 10 A (see Fuse Inspection in the Electrical System chapter)
  - Front Brake Light Switch [A] (see Switch Inspection in the Electrical System chapter)
  - Rear Brake Light Switch (see Switch Inspection in the Electrical System chapter)
  - Harness (see Wiring Inspection in the Electrical System chapter)



## Suspensions

### Front Forks/Rear Shock Absorber Operation Inspection

- Pump the forks down and up [A] 4 or 5 times, and inspect the smooth stroke.
  - ★ If the forks do not smoothly or noise is found, inspect the fork oil level or fork clamps (see Front Fork Oil Change in the Suspension chapter).
- 
- Pump the seat down and up [A] 4 or 5 times, and inspect the smooth stroke.
  - ★ If the shock absorber does not smoothly stroke or noise is found, inspect the oil leak or shock absorber clamps (see Rear Shock Absorber Oil Leak Inspection in this chapter).



## 2-38 PERIODIC MAINTENANCE

### Maintenance Procedure

#### *Front Fork Oil Leak Inspection*

- Visually inspect the front forks [A] for oil leakage.
- ★ Replace or repair any defective parts, if necessary.



#### *Rear Shock Absorber Oil Leak Inspection*

- Visually inspect the shock absorber [A] for oil leakage.
- ★ If the oil leakage is found on it, replace the shock absorber with a new one.

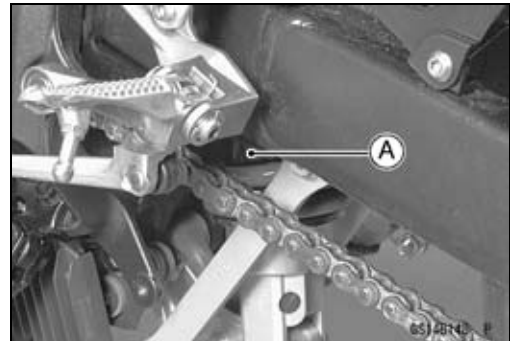

#### *Rocker Arm Operation Inspection*

- Remove the lower fairings (see Lower Fairing Removal in the Frame chapter).
- Pump the seat down and up 4 or 5 times, and inspect the smooth stroke.
- ★ If the rocker arm [A] does not smoothly stroke or noise is found, inspect the fasteners and bearings (see Rocker Arm/Tie-Rod Bearing, Sleeve Inspection in the Suspension chapter).

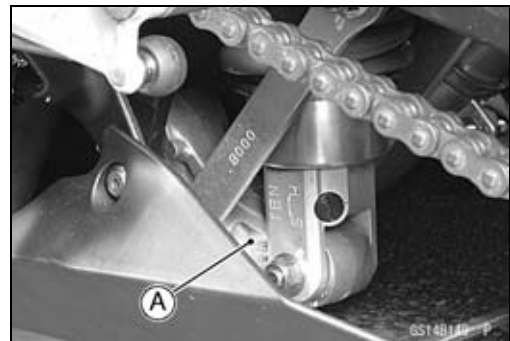

#### *Tie-Rod Operation Inspection*

- Remove the lower fairings (see Lower Fairing Removal in the Frame chapter).
- Pump the seat down and up 4 or 5 times, and inspect the smooth stroke.
- ★ If the tie-rods [A] do not smoothly stroke or noise is found, inspect the fasteners and tie-rod bearings (see Rocker Arm/Tie-Rod Bearing, Sleeve Inspection in the Suspension chapter).

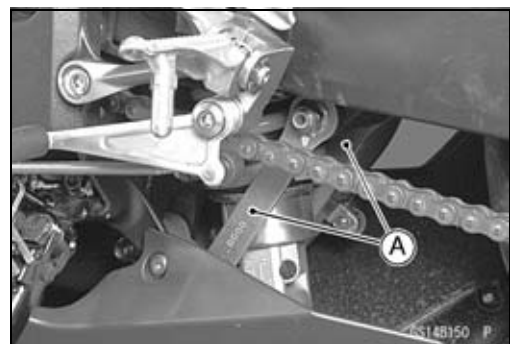

## Maintenance Procedure

### Steering System

#### Steering Play Inspection

- Remove the lower fairings (see Lower Fairing Removal in the Frame chapter).
- Lift the front wheel off the ground using the jack.

**Special Tools - Jack: 57001-1238**

**Jack Attachment: 57001-1608**

- With the front wheel pointing straight ahead, alternately tap each end of the handlebar. The front wheel should swing fully left and right from the force of gravity until the fork hits the stop.
- ★ If the wheel binds or catches before the stop, the steering is too tight.
- Feel for steering looseness by pushing and pulling the forks.
- ★ If you feel looseness, the steering is too loose.

#### NOTE

- The cables and wiring will have some effect on the motion of the fork which must be taken into account.
- Be sure the wires and cables are properly routed.
- The bearings must be in good condition and properly lubricated in order for any test to be valid.

#### Steering Play Adjustment

- Remove:
  - Stem Head Nut [A] and Washer [B]
- Loosen the upper fork clamp bolts [C] and handlebar bolts [D].
- Remove the stem head [E] with handlebar.

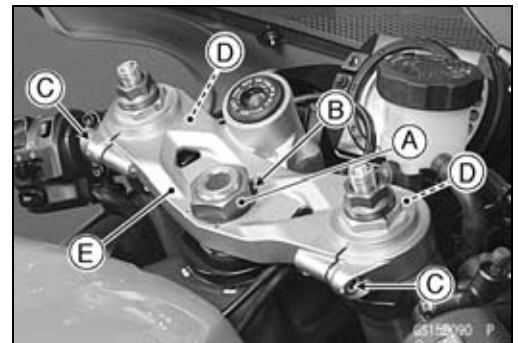

- Bend the claw washer tabs [A].
- Remove the steering stem locknut [B] and claw washer [C].

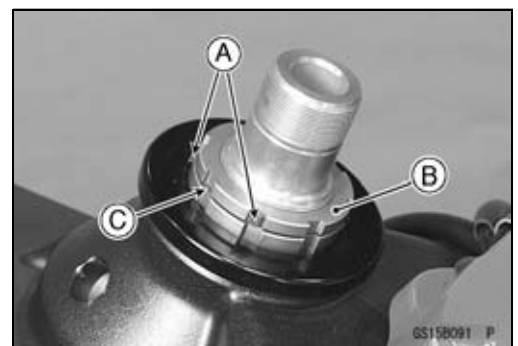

- Adjust the steering.
  - Special Tool - Steering Stem Nut Wrench: 57001-1100**
  - ★ If the steering is too tight, loosen the stem nut a fraction of a turn.
  - ★ If the steering is too loose, tighten the stem nut a fraction of a turn.

#### NOTE

- Turn the stem nut 1/8 turn at time maximum.

## 2-40 PERIODIC MAINTENANCE

### Maintenance Procedure

- Install the claw washer [A] so that its bent side [B] faces upward, and engage the bent claws with the grooves of stem locknut [C].
- Hand tighten the stem locknut until it touches the claw washer.
- Tighten the stem locknut clockwise until the claws are aligned with the grooves (ranging from 2nd to 4th) of stem nut [D], and bend the 2 claws downward [E].

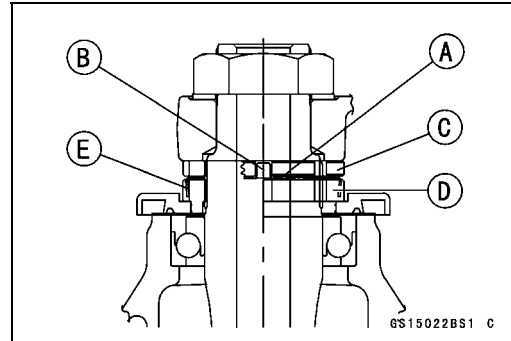

- Tighten:
  - Torque - Upper Front Fork Clamp Bolts: 20 N·m (2.0 kgf·m, 15 ft·lb)**
  - Handlebar Bolts: 25 N·m (2.5 kgf·m, 18 ft·lb)**
  - Steering Stem Head Nut: 78 N·m (8.0 kgf·m, 58 ft·lb)**
- Check the steering again.
- ★ If the steering is still too tight or too loose, repeat the adjustment.

#### Steering Stem Bearing Lubrication

- Remove the steering stem (see Stem, Stem Bearing Removal in the Steering chapter).
- Using a high-flash point solvent, wash the upper and lower ball bearings in the cages, and wipe the upper and lower outer races, which are press-fitted into the frame head pipe, clean off grease and dirt.
- Visually check the outer races and the ball bearings.
- ★ Replace the bearing assemblies if they show wear or damage.
- Pack the upper and lower ball bearings [A] in the cages with grease, and apply a light coat of grease to the upper and lower outer races.
- Install the steering stem (see Stem, Stem Bearing Installation in the Steering chapter).
- Adjust the steering (see Steering Play Adjustment in this chapter).

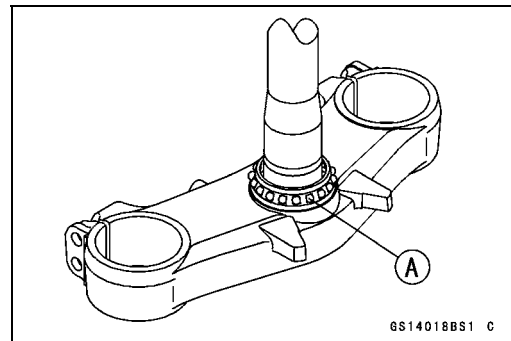

### Electrical System

#### Spark Plug Clean and Gap Inspection

- Remove the spark plug (see Spark Plug Replacement in this chapter), and visually inspect.
- Clean the spark plug, preferably in a sandblasting device, and then clean off any abrasive particles. The plug may also be cleaned using a high-flash point solvent and a wire brush or other suitable tool.
- ★ If the spark plug electrodes are corroded or damaged, or if the insulator is cracked, replace the plug. Use the standard spark plug or its equivalent.

**Maintenance Procedure**

- Measure the gap [A] with a wire-type thickness gauge.
- ★ If the gap is incorrect, carefully bend the side electrode [B] with a suitable tool to obtain the correct gap.

**Spark Plug Gap : 0.7 ~ 0.8 mm (0.028 ~ 0.031 in.)**

**CAUTION**

**Use only the recommended spark plugs (special marks <sup>NGK</sup><sub>R</sub>). These spark plugs have special marks [C] on the insulator, as shown. Other spark plugs will wear prematurely.**

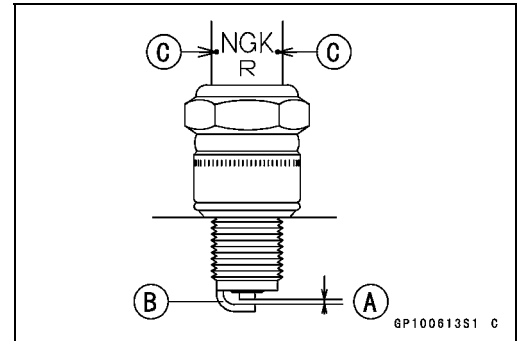

## 2-42 PERIODIC MAINTENANCE

### Maintenance Procedure

#### Lights and Switches Operation Inspection

##### First Step

- Turn on the ignition switch.
- The following lights should go on according to below table.

City Light [A]	goes on
Taillight [B]	goes on
License Plate Light [C]	goes on
Meter Panel LCD [D]	goes on
Neutral Indicator LED [E]	goes on
Oil Pressure Warning Indicator LED [F]	goes on
FI Indicator LED [G]	goes on (about 2 seconds)

- ★ If the light does not go on, inspect or replace the following item.

Battery (see Charging Condition Inspection in the Electrical System chapter)

Applicable Bulb (see Wiring Diagram in the Electrical System chapter)

Meter Unit for Meter Panel LCD (see Electronic Combination Meter Assembly Inspection in the Electrical System chapter)

Meter Unit for Neutral Indicator LED (see Electronic Combination Meter Assembly Inspection in the Electrical System chapter)

Meter Unit for Oil Pressure Warning Indicator LED (see Electronic Combination Meter Assembly Inspection in the Electrical System chapter)

Meter Unit for FI Indicator LED (see Electronic Combination Meter Assembly Inspection in the Electrical System chapter)

ECU (see ECU Power Supply Inspection in the Fuel System (DFI) chapter)

Main Fuse 30 A and Taillight Fuse 10 A (see Fuse Inspection in the Electrical System chapter)

Ignition Switch (see Switch Inspection in the Electrical System chapter)

Neutral Switch (see Switch Inspection in the Electrical System chapter)

Harness (see Wiring Inspection in the Electrical System chapter)

- Turn off the ignition switch.
- The all lights should go off (for the immobilizer model, FI indicator LED will blink. see Abstract in the Electrical System chapter).

- ★ If the light does not go off, replace the ignition switch.

##### Second Step

- Turn the ignition switch to P (Park) position.
- The city light, taillight and license plate light should go on.

- ★ If the light does not go on, inspect or replace the following item.

Ignition Switch (see Switch Inspection in the Electrical System chapter)

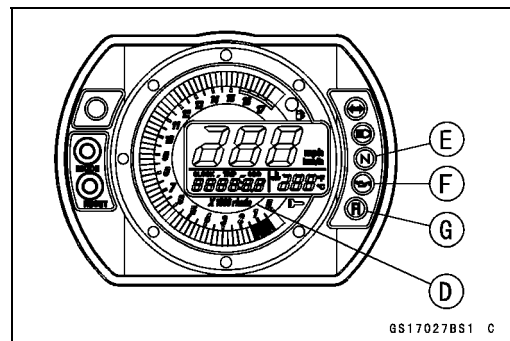
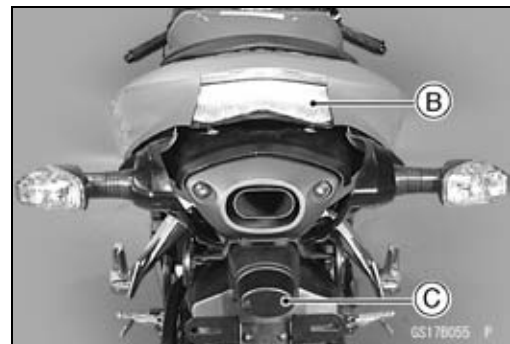

**Maintenance Procedure**

**Third Step**

- Turn on the turn signal switch [A] (left or right position).
- The left or right turn signal lights [B] (front and rear) according to the switch position should flash.
- The turn signal indicator LED [C] in the meter unit should flash.

★ If the each light does not flash, inspect or replace the following item.

Turn Signal Light Bulb (see Turn Signal Light Bulb Replacement in the Electrical System chapter)

Meter Unit for Turn Signal Light Indicator LED (see Electronic Combination Meter Assembly Inspection in the Electrical System chapter)

Turn Signal Relay Fuse 10 A (see Fuse Inspection in the Electrical System chapter)

Turn Signal Switch (see Switch Inspection in the Electrical System chapter)

Turn Signal Relay (see Turn Signal Relay Inspection in the Electrical System chapter)

Harness (see Wiring Inspection in the Electrical System chapter)

- Push the turn signal switch.
  - The turn signal lights and indicator LED should go off.
- ★ If the light does not go off, inspect or replace the following item.

Turn Signal Switch (see Switch Inspection in the Electrical System chapter)

Turn Signal Relay (see Turn Signal Relay Inspection in the Electrical System chapter)

**Fourth Step**

- Set the dimmer switch [A] to low beam position.
  - Start the engine.
  - The low beam headlight should go on.
- ★ If the low beam headlight does not go on, inspect or replace the following item.

Headlight Low Beam Bulb (see Headlight Bulb Replacement in the Electrical System chapter)

Headlight Fuse 10 A (see Fuse Inspection in the Electrical System chapter)

Dimmer Switch (see Switch Inspection in the Electrical System chapter)

Headlight Relay in Relay Box (see Relay Circuit Inspection in the Electrical System chapter)

Harness (see Wiring Inspection in the Electrical System chapter)

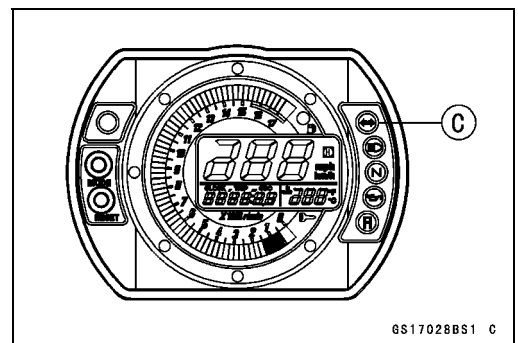
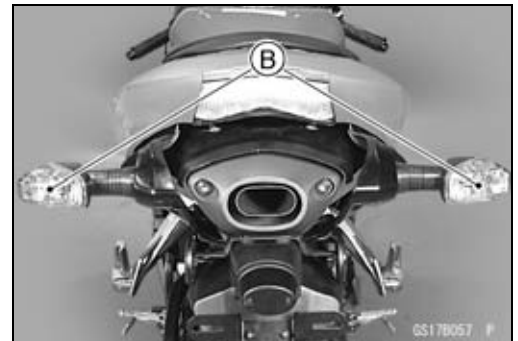

## 2-44 PERIODIC MAINTENANCE

### Maintenance Procedure

- Set the dimmer switch to high beam position.
- The low beam [A] and high beam [B] headlights should go on.
- The high beam indicator LED [C] should go on.
- ★ If the high beam headlight and/or high beam indicator LED does not go on, inspect or replace the following item.
  - Headlight High Beam Bulb (see Headlight Bulb Replacement in the Electrical System chapter)
  - Dimmer Switch (see Switch Inspection in the Electrical System chapter)
- Turn off the engine stop switch.
- The low beam and high beam headlights should stay going on.
- ★ If the headlights and high beam indicator LED does go off, inspect or replace the following item.
  - Headlight Relay in Relay Box (see Relay Circuit Inspection in the Electrical System chapter)
- Turn off the ignition switch.
- The headlights and high beam indicator LED should go off.

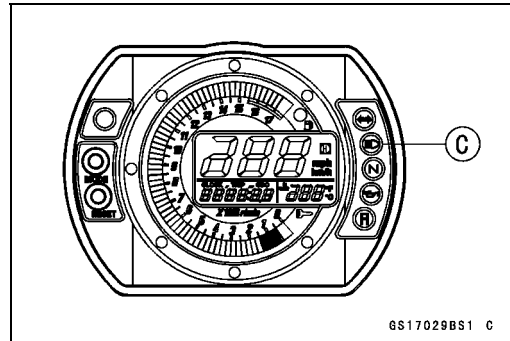
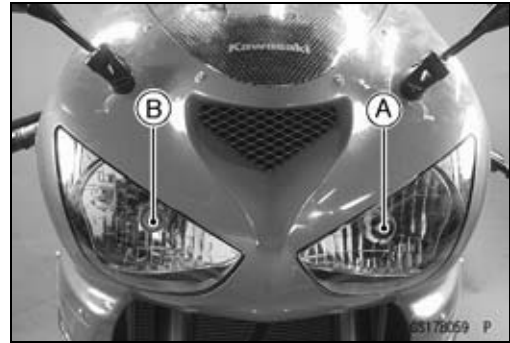

#### Headlight Aiming Inspection

- Inspect the headlight beam for aiming.
- ★ If the headlight beam points to one side rather than straight ahead, adjust the horizontal beam.

#### Headlight Beam Horizontal Adjustment

- Turn the horizontal adjuster [A] in both headlights in or out until the beam points straight ahead.
- ★ If the headlight beam points too low or high, adjust the vertical beam.

#### Headlight Beam Vertical Adjustment

- Turn the vertical adjuster [B] in both headlights in or out with a screwdriver to adjust the headlight vertically.

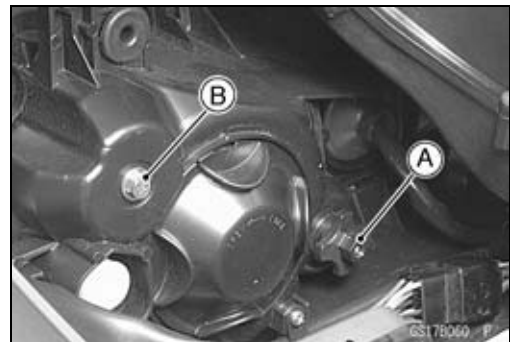

**Maintenance Procedure**

**NOTE**

- ON high beam, the brightest points should be slightly below horizontal with the motorcycle on its wheels and the rider seated. Adjust the headlight to the proper angle according to local regulations.
- For US model, the proper angle is 0.4 degrees below horizontal. This is 50 mm (2 in.) drop at 7.6 m (25 ft) measured from the center of the headlight with the motorcycle on its wheels and the rider seated.

- 50 mm (2 in.) [A]
- Center of Brightest Spot [B]
- 7.6 m (25 ft) [C]
- Low Beam [D]
- Height of Headlight Center [E]
- High Beam [F]

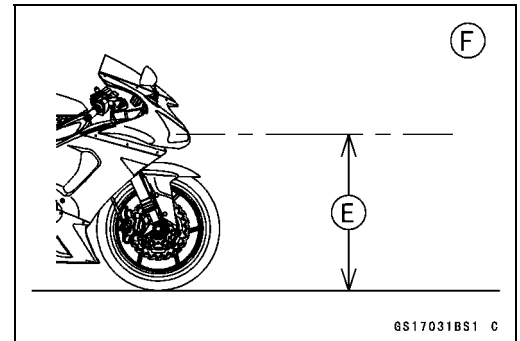
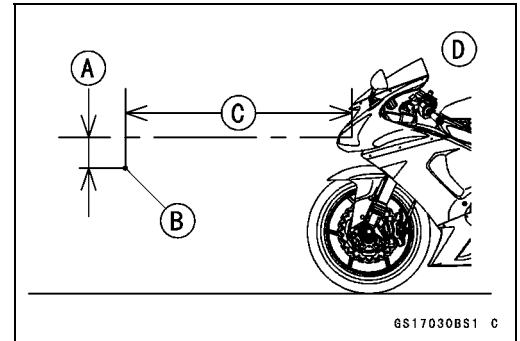

**Side Stand Switch Operation Inspection**

- Inspect the side stand switch [A] operation accordance to below table.

**Side Stand Switch Operation**

Side Stand	Gear Position	Clutch Lever	Engine Start	Engine Run
Up	Neutral	Released	Starts	Continue running
Up	Neutral	Pulled in	Starts	Continue running
Up	In Gear	Released	Doesn't start	Continue running
Up	In Gear	Pulled in	Starts	Continue running
Down	Neutral	Released	Starts	Continue running
Down	Neutral	Pulled in	Starts	Continue running
Down	In Gear	Released	Doesn't start	Stops
Down	In Gear	Pulled in	Doesn't start	Stops

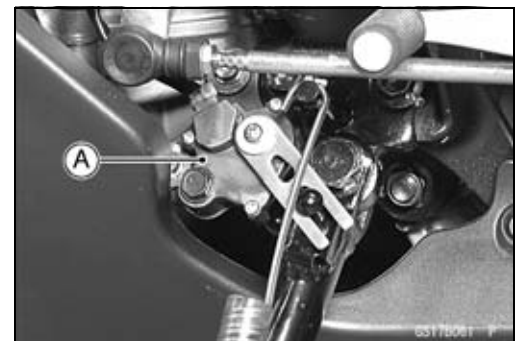

## 2-46 PERIODIC MAINTENANCE

### Maintenance Procedure

★ If the side stand switch operation does not work, inspect or replace the following item.

Battery (see Charging Condition Inspection in the Electrical System chapter)

Main Fuse 30 A (see Fuse Inspection in the Electrical System chapter)

Ignition Fuse 10 A (see Fuse Inspection in the Electrical System chapter)

Ignition Switch (see Switch Inspection in the Electrical System chapter)

Side Stand Switch (see Switch Inspection in the Electrical System chapter)

Engine Stop Switch (see Switch Inspection in the Electrical System chapter)

Starter Button (see Switch Inspection in the Electrical System chapter)

Neutral Switch (see Switch Inspection in the Electrical System chapter)

Starter Control Relay (see Starter Relay Inspection in the Electrical System chapter)

Relay Box (see Relay Circuit Inspection in the Electrical System chapter)

Starter Circuit Relay (see Relay Circuit Inspection in the Electrical System chapter)

Harness (see Wiring Inspection in the Electrical System chapter)

★ If all parts are in good condition, replace the ECU.

#### *Engine Stop Switch Operation Inspection*

##### **First Step**

- Turn on the ignition switch.
  - Set the neutral position.
  - Turn the engine stop switch to stop position [A].
  - Push the starter button.
  - The engine does not start.
- ★ If the engine starts, inspect or replace the following item.
- Engine Stop Switch (see Switch Inspection in the Electrical System chapter)

##### **Second Step**

- Turn on the ignition switch.
  - Set the neutral position.
  - Turn the engine stop switch to run position [A].
  - Push the starter button and run the engine.
  - Turn the engine stop switch to stop position.
  - Immediately the engine should be stop.
- ★ If the engine does not stop, inspect or replace the following item.
- Engine Stop Switch (see Switch Inspection in the Electrical System chapter)
- ★ If the engine stop switch is in good condition, replace the ECU (see ECU Removal/Installation in the Fuel System (DFI) chapter).



**Maintenance Procedure**

**Others**

*Chassis Parts Lubrication*

- Before lubricating each part, clean off any rusty spots with rust remover and wipe off any grease, oil, dirt, or grime.
- Lubricate the points listed below with indicated lubricant.

**NOTE**

○ *Whenever the vehicle has been operated under wet or rainy conditions, or especially after using a high-pressure water spray, perform the general lubrication*

**Pivots: Lubricate with Grease.**

- Brake Lever
- Brake Pedal
- Clutch Lever
- Rear Brake Joint Pin
- Side Stand

**Points: Lubricate with Grease.**

- Clutch Inner Cable Upper and Lower Ends [A]
- Throttle Inner Cable Upper and Lower Ends

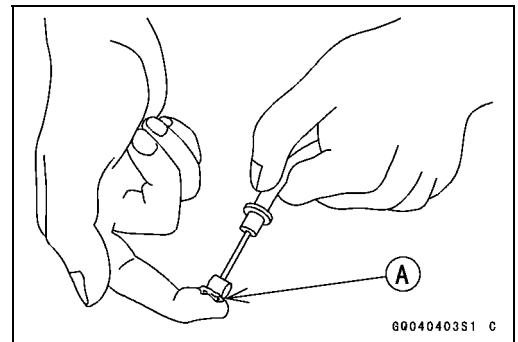

**Cables: Lubricate with Rust Inhibitor**

- Clutch Cable
- Throttle Cables

- Lubricate the cables by seeping the oil between the cable and housing.
- The cable may be lubricated by using a commercially available pressure cable lubricator with an aerosol cable lubricant.

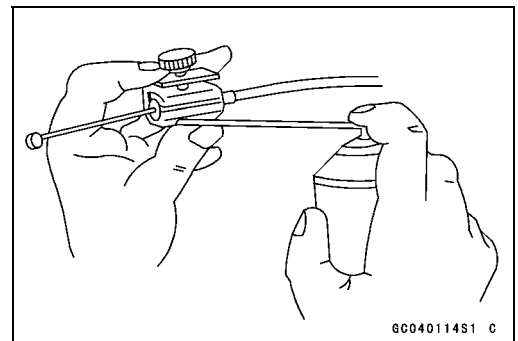

## 2-48 PERIODIC MAINTENANCE

### Maintenance Procedure

- With the cable disconnected at both ends, the inner cable should move freely [A] within the cable housing.
- ★ If cable movement is not free after lubricating, if the cable is frayed [B], or if the cable housing is kinked [C], replace the cable.

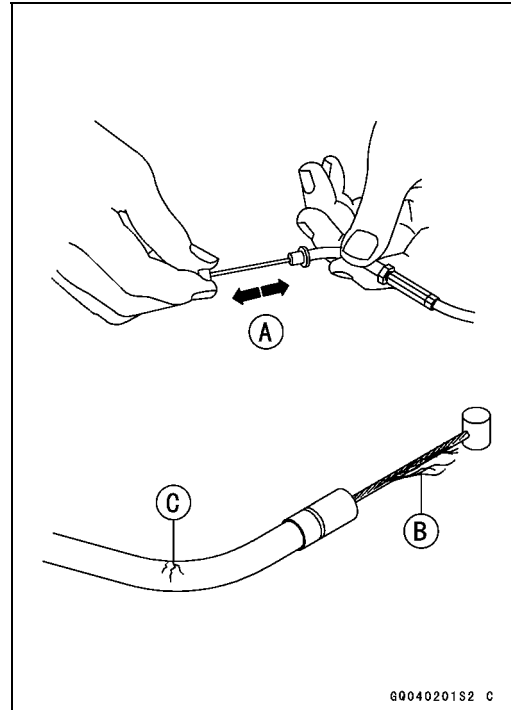

#### *Bolts, Nuts and Fasteners Tightness Inspection*

- Check the tightness of the bolts and nuts listed here. Also, check to see that each cotter pin is in place and in good condition.

#### **NOTE**

○ *For the engine fasteners, check the tightness of them when the engine is cold (at room temperature).*

- ★ If there are loose fasteners, retorque them to the specified torque following the specified tightening sequence. Refer to the appropriate chapter for torque specifications. If torque specifications are not in the appropriate chapter, see the Standard Torque Table. For each fastener, first loosen it by 1/2 turn, then tighten it.
- ★ If cotter pins are damaged, replace them with new ones.

---

**Maintenance Procedure**

---

**Bolt, Nut and Fastener to be checked**

Engine:

- Clutch Lever Pivot Nut
- Engine Mounting Bolts
- Exhaust Pipe Clamp Bolts
- Exhaust Pipe Manifold Holder Nuts
- Muffler Body Mounting Bolts

Wheels:

- Front Axle Clamp Bolts
- Front Axle Nut
- Rear Axle Nut
- Rear Axle Nut Cotter Pin

Brakes:

- Brake Lever Pivot Nut
- Brake Pedal Bolt
- Brake Rod Joint Cotter Pin
- Caliper Mounting Bolts
- Front Master Cylinder Clamp Bolts
- Rear Master Cylinder Mounting Bolts

Suspension:

- Front Fork Clamp Bolts
- Rear Shock Absorber Mounting Nuts
- Swingarm Pivot Shaft Nut
- Uni-Trak Link Nuts

Steering:

- Handlebar Bolts
- Steering Stem Head Nut

Others:

- Footpeg Bracket Bolts
- Front Fender Mounting Bolts
- Side Stand Bolt

## 2-50 PERIODIC MAINTENANCE

### Maintenance Procedure

#### Replacement Parts

##### Air Cleaner Element Replacement

#### NOTE

- In dusty areas, the element should be replaced more frequently than the recommended interval.
- After riding through rain or on muddy roads, the element should be replaced immediately.

#### ⚠ WARNING

If dirt or dust is allowed to pass through into the throttle assy, the throttle may become stuck, possibly causing an accident.

#### CAUTION

If dirt gets through into the engine, excessive engine wear and possibly engine damage will occur.

- Remove:
  - Front Seat (see Front Seat Removal in the Frame chapter)
- Lift up the fuel tank, and clamp the fuel tank by wood.
- Remove:
  - Air Cleaner Element Cover Screws [A]
  - Air Cleaner Element Cover [B]
- Discard:
  - Air Cleaner Element
- Install a new element [A].

#### CAUTION

Use only the recommended air cleaner element (Kawasaki part number 11013-0010). Using another air cleaner element will wear the engine prematurely or lower the engine performance.

#### NOTE

- Be sure to install the fuel tank drain hose.

##### Fuel Hose Replacement

- Remove the fuel tank (see Fuel Tank Removal in the Fuel System (DFI) chapter).
- Be sure to place a piece of cloth [A] around the fuel hose joint.
- Push [B] the joint lock claws [C].

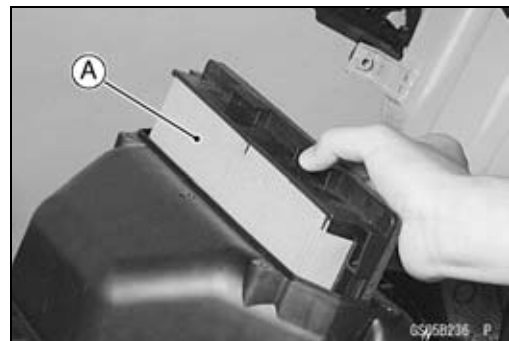
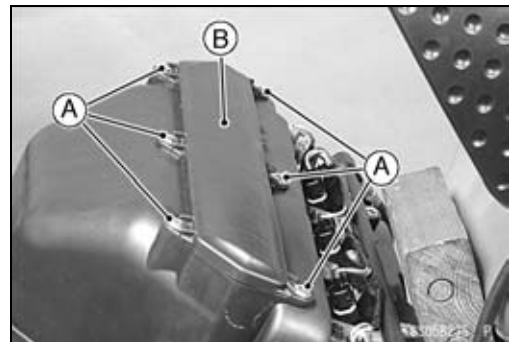

**Maintenance Procedure**

- Pull the joint lock [A] as shown.
- Pull the fuel hose joint [B] out of the delivery pipe.

**⚠ WARNING**  
**Be prepared for fuel spillage; any spilled fuel must be completely wiped up immediately. When the fuel hose is disconnected, fuel spills out from the hose and the pipe. Cover the hose connection with a clean shop towel to prevent fuel spillage.**

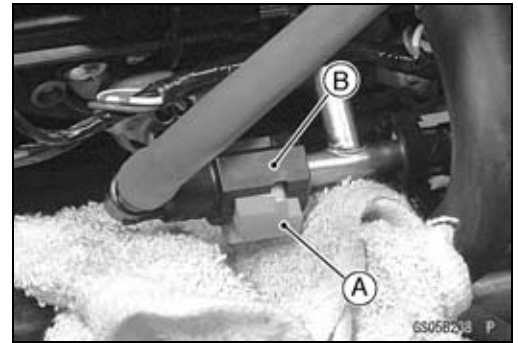

- Install the new fuel hose.
- Pull [A] the joint lock [B] fully as shown.

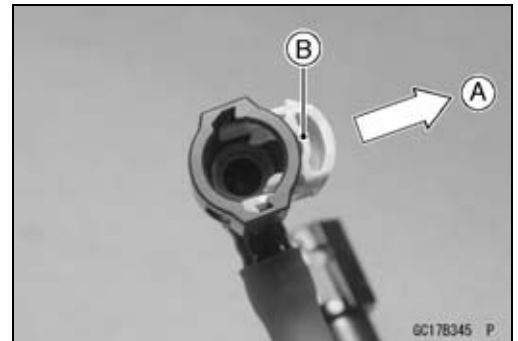

- Insert the fuel hose joint [A] straight onto the delivery pipe until the hose joint clicks.
- Push [B] the joint lock [C] until the hose joint clicks.

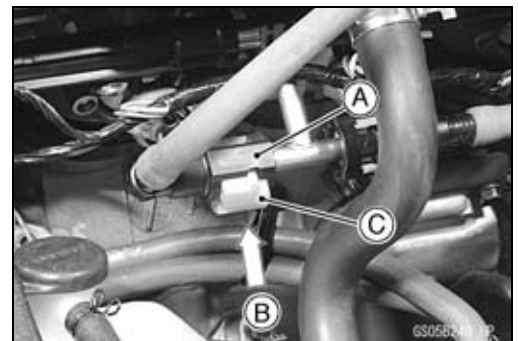

- Push and pull [A] the fuel hose joint [B] back and forth more than two times and make sure it is locked and doesn't come off.

**⚠ WARNING**  
**Make sure the fuel hose joint is installed correctly on the delivery pipe or the fuel could leak.**

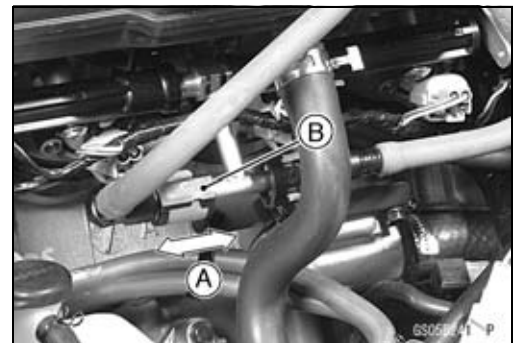

- ★ If it comes off, reinstall the hose joint.
- Run the fuel hose in accordance with the Cable, Wire, and Hose Routing section in the Appendix chapter.
- Install the removed parts (see appropriate chapters).
- Start the engine and check the fuel hose for leaks.

## 2-52 PERIODIC MAINTENANCE

### Maintenance Procedure

#### Coolant Change

#### **⚠ WARNING**

To avoid burns, do not remove the radiator cap or try to change the coolant when the engine is still hot. Wait until it cools down. Coolant on tires will make them slippery and can cause an accident and injury. Immediately wipe up or wash away any coolant that spills on the frame, engine, or other painted parts. Since coolant is harmful to the human body, do not use for drinking.

- Remove:
  - Lower Fairings (see Lower Fairing Removal in the Frame chapter)
  - Right Center Fairing (see Center Fairing Removal in the Frame chapter)
  - Radiator Cap [A]
- Remove the radiator cap in two steps. First turn the cap counterclockwise to the first stop. Then push and turn it further in the same direction and remove the cap.

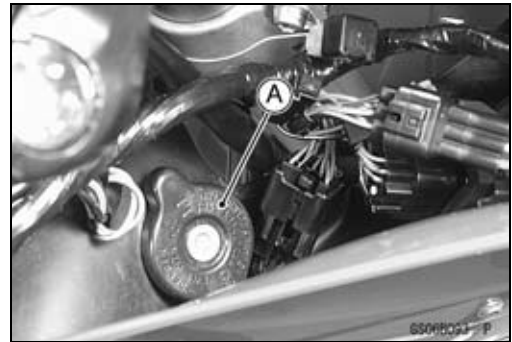

- Remove:
  - Left Center Fairing (see Center Fairing Removal in the Frame chapter)
- Place a containers under the drain bolts [A] [B] of the water pump cover and cylinder.
- Drain the coolant from the radiator and engine by removing the drain bolts.

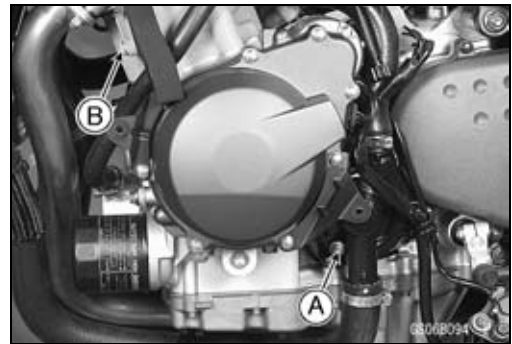

- Remove:
  - Coolant Reserve Tank [A] (see Coolant Reserve Tank Removal in the Cooling System chapter)
- Remove the cap [B] and pour the coolant into a container.

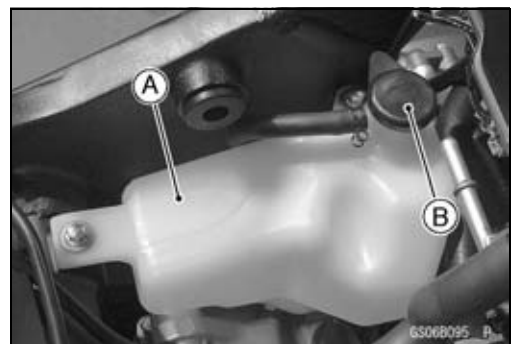

- Install the coolant reserve tank (see Coolant Reserve Tank Installation in the Cooling System chapter).
- Tighten the drain bolts with the washers.
- Replace the drain bolt gasket with a new one if it is damaged.

**Torque - Coolant Drain Bolt (Water Pump): 8.8 N·m (0.90 kgf·m, 78 in·lb)**  
**Coolant Drain Bolt (Cylinder): 9.8 N·m (1.0 kgf·m, 87 in·lb)**

**Maintenance Procedure**

- Fill the radiator up to the radiator filler neck [A] with coolant, and install the radiator cap.

**NOTE**

○ Pour in the coolant slowly so that it can expel the air from the engine and radiator.

- Fill the reserve tank up to the full level line with coolant, and install the cap.



**CAUTION**

**Soft or distilled water must be used with the antifreeze (see below for antifreeze) in the cooling system.**

**If hard water is used in the system, it causes scales accumulation in the water passages, and considerably reduces the efficiency of the cooling system.**

**Water and Coolant Mixture Ratio (Recommended)**

- Soft Water: 50%
- Coolant: 50%
- Freezing Point: -35°C (-31°F)
- Total Amount: 2.6 L (2.7 US qt)

**NOTE**

○ Choose a suitable mixture ratio by referring to the coolant manufacturer's directions.

- Bleed the air from the cooling system as follows.
  - Start the engine with the radiator cap removed and run it until no more air bubbles [A] can be seen in the coolant.
  - Tap the radiator hoses to force any air bubbles caught inside.
  - Stop the engine and add coolant up to the radiator filler neck.
- Install the radiator cap.
- Start the engine, warm it up thoroughly until the radiator fan turns on and then stop the engine.
- Check the coolant level in the reserve tank after the engine cools down.
- ★ If the coolant level is lower than the low level line, add coolant to the full level line.

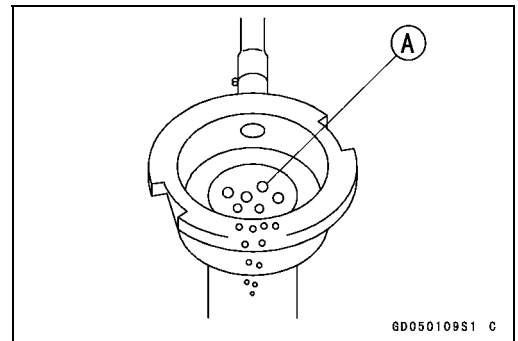

**CAUTION**

**Do not add more coolant above the full level line.**

## 2-54 PERIODIC MAINTENANCE

### Maintenance Procedure

#### Radiator Hose and O-ring Replacement

- Drain the coolant (see Coolant Change in this chapter).
- Remove:
  - Lower Fairings (see Lower Fairing Removal in the Frame chapter)
  - Center Fairings (see Center Fairing Removal in the Frame chapter)
  - Throttle Body Assy (see Throttle Body Assy Removal in the Fuel System (DFI) chapter)
  - Thermostat Housing [A]
  - Fitting [B]
  - Hoses [C]
  - O-rings [D]
- Apply grease to the new O-rings and install them.
- Install the new hoses and tighten the clamps securely.
- Fill the coolant (see Coolant Change in this chapter).
- Check the cooling system for leaks.

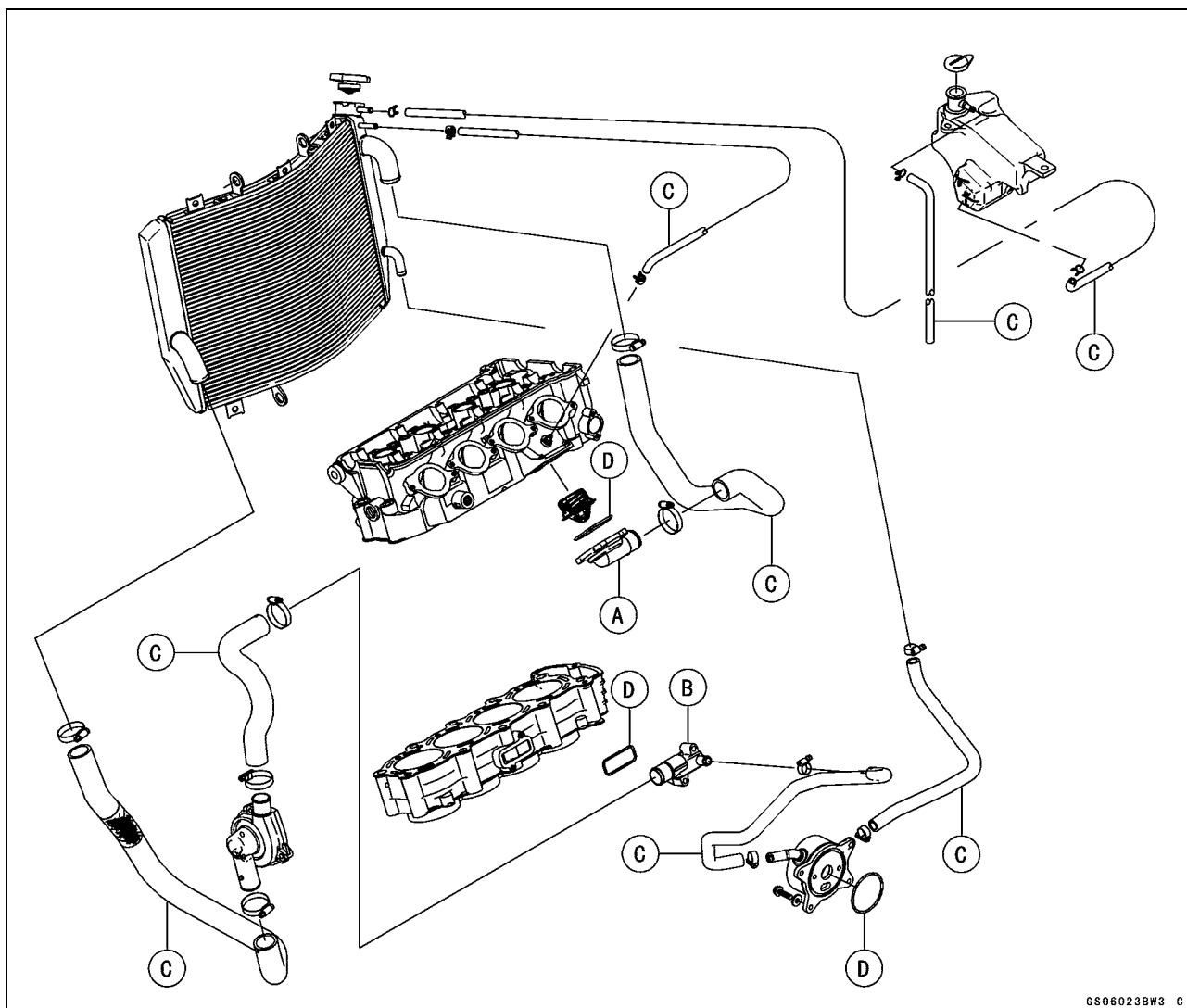

6S060238W3 C

**Maintenance Procedure**

**Engine Oil Change**

- Remove the lower fairings (see Lower Fairing Removal in the Frame chapter).
- Situate the motorcycle so that it is vertical after warming up the engine.
- Remove the engine oil drain bolt [A] to drain the oil.
- The oil in the oil filter can be drained by removing the filter (see Oil Filter Replacement in this chapter).
- ★ Replace the drain bolt gasket with a new one.
- Tighten the drain bolt.

**Torque - Engine Oil Drain Bolt: 29 N·m (3.0 kgf·m, 22 ft·lb)**

- Pour in the specified type and amount of oil.

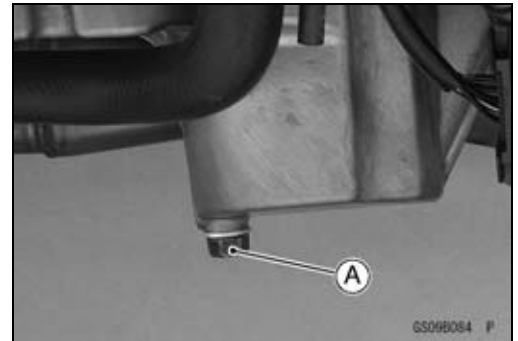

**Recommended Engine Oil**

**Type:** API SE, SF or SG

API SH or SJ with JASO MA

**Viscosity:** SAE 10W-40

**Capacity:** 3.4 L (3.6 US qt) (when filter is not removed)

3.6 L (3.8 US qt) (when filter is removed)

4.0 L (4.2 US qt) (when engine is completely dry)

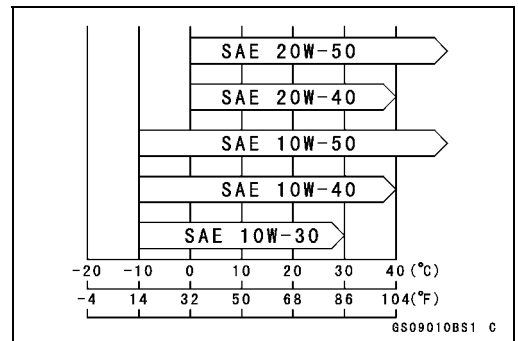

**NOTE**

○ Although 10W-40 engine oil is the recommended oil for most conditions, the oil viscosity may need to be changed to accommodate atmospheric conditions in your riding area.

**Oil Filter Replacement**

- Drain the engine oil (see Engine Oil Change in this chapter).
- Remove the oil filter [A] with the oil filter wrench [B].

**Special Tool - Oil Filter Wrench: 57001-1249**

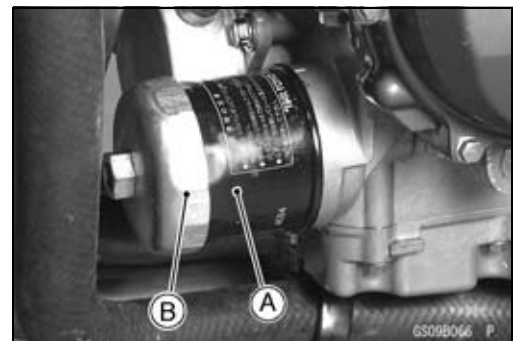

- Replace the filter with a new one.
- Apply engine oil to the gasket [A] before installation.
- Tighten the filter with the oil filter wrench.

**Torque - Oil Filter: 31 N·m (3.2 kgf·m, 23 ft·lb)**

**NOTE**

○ Hand tightening of the oil filter can not be allowed since it does not reach to this tightening torque.

- Pour in the specified type and amount of oil (see Engine Oil Change in this chapter).

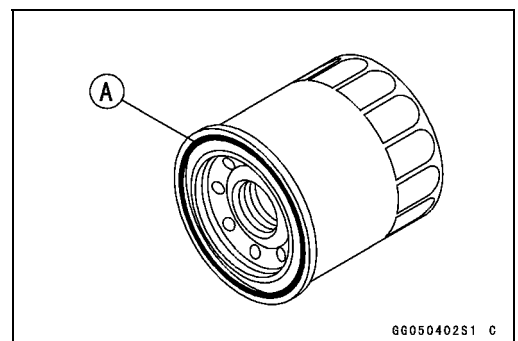

## 2-56 PERIODIC MAINTENANCE

### Maintenance Procedure

#### Brake Hose and Pipe Replacement

#### CAUTION

**Brake fluid quickly ruins painted plastic surfaces; any spilled fluid should be completely washed away immediately.**

- When removing the brake hose, take care not to spill the brake fluid on the painted or plastic parts.
- When removing the brake hoses [A], temporarily secure the end of the brake hose to some high place to keep fluid loss to a minimum.
- Immediately wash away any brake fluid that spills.
- There are washers on each side of the brake hose fitting. Replace them with new ones when installing.
- Tighten:  
**Torque - Brake Hose Banjo Bolts: 34 N·m (3.5 kgf·m, 25 ft·lb)**
- When installing the hoses [A], avoid sharp bending, kinking, flattening or twisting, and route the hoses according to Cable, Wire, and Hose Routing section in the Appendix chapter.
- Fill the brake line after installing the brake hose (see Brake Fluid Change in this chapter).

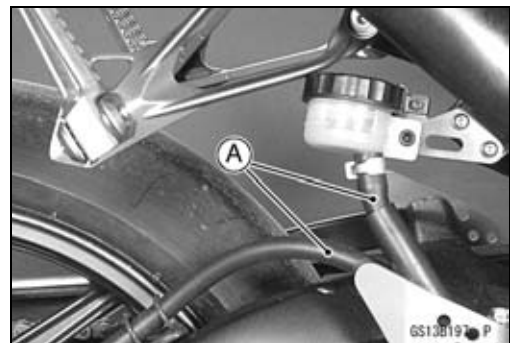
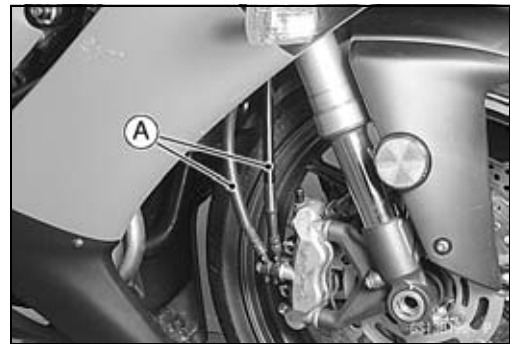
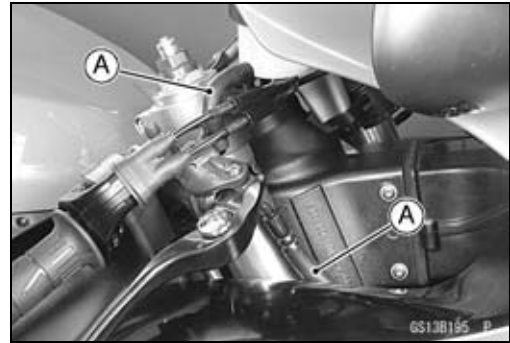

#### Brake Fluid Change

#### NOTE

- *The procedure to change the front brake fluid is as follows. Changing the rear brake fluid is the same as for the front brake.*

**Maintenance Procedure**

- Level the brake fluid reservoir.
- Remove the reservoir cap.
- Remove the rubber cap from the bleed valve [A] on the caliper.
- Attach a clear plastic hose [B] to the bleed valve, and run the other end of the hose into a container.
- Fill the reservoir with fresh specified brake fluid.

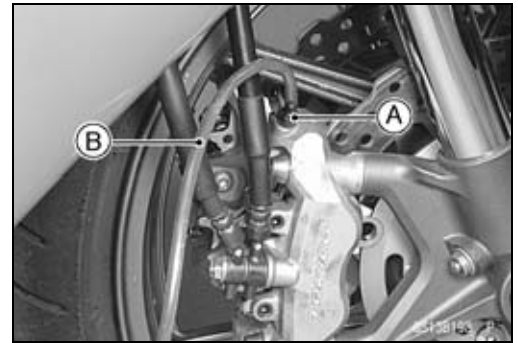

- Change the brake fluid.
- Repeat this operation until fresh brake fluid comes out from the plastic hose or the color of the fluid changes.
  1. Open the bleed valve [A].
  2. Apply the brake and hold it [B].
  3. Close the bleed valve [C].
  4. Release the brake [D].

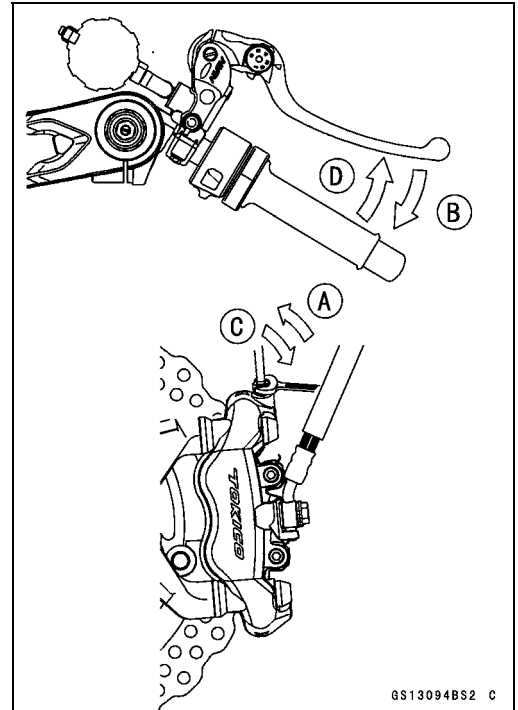

**NOTE**

- The fluid level must be checked often during the changing operation and replenished with fresh brake fluid. If the fluid in the reservoir runs out any time during the changing operation, the brakes will need to be bled since air will have entered the brake line.
- Front Brake: Repeat the above steps for the other caliper.

- Follow the procedure below to install the front/rear brake fluid reservoir cap correctly.
  - First, tighten the front/rear brake fluid reservoir cap [B] clockwise [C] by hand until the resistance is felt fully; then, tighten the cap an additional 1/6 turn [D] while holding the brake fluid reservoir body [A].

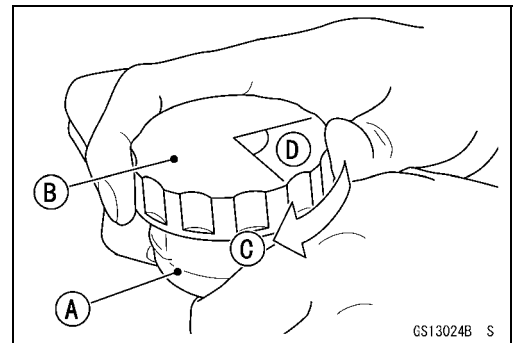

- Tighten:
  - Torque - Front Brake Reservoir Cap Stopper Screw: 1.2 N·m (0.12 kgf·m, 10 in·lb)**
- Tighten the bleed valve, and install the rubber cap.
  - Torque - Bleed Valve: 7.8 N·m (0.80 kgf·m, 69 in·lb)**
- After changing the fluid, check the brake for good braking power, no brake drag, and no fluid leakage.
- ★ If necessary, bleed the air from the lines.

## 2-58 PERIODIC MAINTENANCE

### Maintenance Procedure

#### Master Cylinder Rubber Parts Replacement

##### Front Master Cylinder Disassembly

- Remove the front master cylinder (see Front Master Cylinder Removal in the Brakes chapter).
- Remove the seal cover [A], circlip [B], connector [C] and O-ring [D].

**Special Tool - Inside Circlip Pliers: 57001-143**

- Unscrew the locknut [E] and pivot bolt [F], and remove the brake lever.
- Pull the dust cover [G] and push rod [H] out of place, and remove the circlip [I].
- Pull out the piston assy [J].
- Replace:
  - Seal Cover [A]
  - Circlip [B]
  - O-ring [D]
  - Dust Cover [G]
  - Circlip [I]
  - Piston Assy [J]
  - Diaphragm [K]

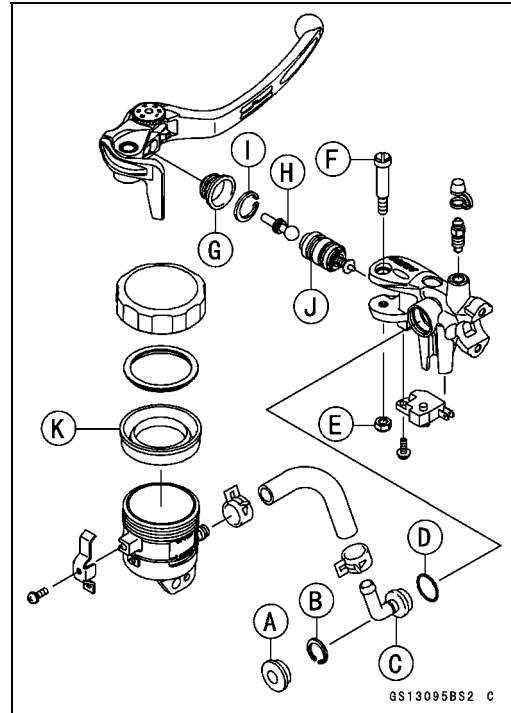

##### Rear Master Cylinder Disassembly

- Remove the rear master cylinder (see Rear Master Cylinder Removal in the Brakes chapter).
- Remove the circlip [A], connector [B] and O-ring [C].

**Special Tool - Inside Circlip Pliers: 57001-143**

- Slide the dust cover [D] out of place, and remove the circlip [E].
- Pull out the push rod assy [F].
- Take off the piston assy [G] and return spring [H].

#### CAUTION

**Do not remove the secondary cup from the piston since removal will damage it.**

- Replace:
  - Circlip [A]
  - O-ring [C]
  - Circlip [E]
  - Push Rod Assy [F]
  - Piston Assy [G]
  - Diaphragm [I]

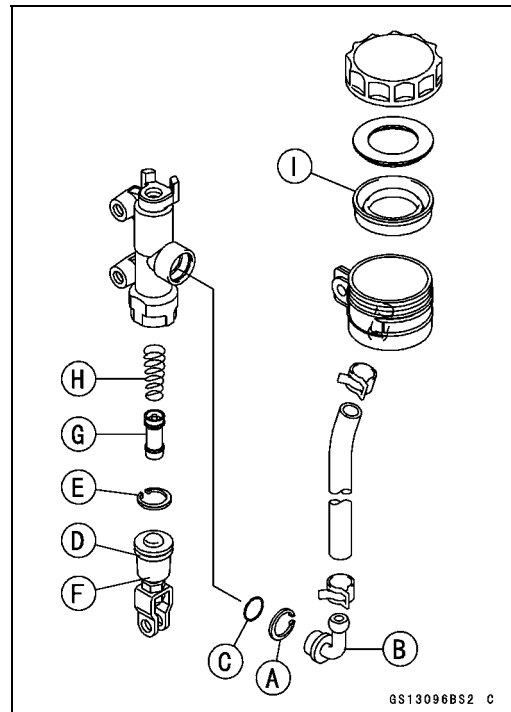

##### Master Cylinder Assembly

- Before assembly, clean all parts including the master cylinder with brake fluid or alcohol.

#### CAUTION

**Except for the disc pads and disc, use only disc brake fluid, isopropyl alcohol, or ethyl alcohol for cleaning brake parts. Do not use any other fluid for cleaning these parts. Gasoline, engine oil, or any other petroleum distillate will cause deterioration of the rubber parts. Oil spilled on any part will be difficult to wash off completely, and will eventually deteriorate the rubber used in the disc brake.**

## Maintenance Procedure

- Apply brake fluid to the new parts and to the inner wall of the cylinder.
- Take care not to scratch the piston or the inner wall of the cylinder.
- Tighten the brake lever pivot bolt and the locknut.

**Silicone Grease - Brake Lever Pivot Bolt**

**Torque - Brake Lever Pivot Bolt: 1.0 N·m (0.10 kgf·m, 9 in·lb)**

**Brake Lever Pivot Bolt Locknut: 5.9 N·m (0.60 kgf·m, 52 in·lb)**

### Caliper Rubber Parts Replacement

#### Front Caliper Disassembly

- Loosen the front caliper pad pins [A] and banjo bolt [B] and tighten them loosely.
- Remove:
  - Front Caliper (see Front Caliper Removal in the Brakes chapter) [C]
  - Brake Pad
  - Front Caliper Assembly Bolts
  - O-rings



- Using compressed air, remove the pistons. One way to remove the pistons is as follows.
  - Install a rubber gasket [A] and a wooden board [B] more than 10 mm (0.4 in.) thick on the caliper half, and fasten them together with a suitable bolt and nut as shown. Leave one of the oil passages [C] open.
  - Lightly apply compressed air [D] to the oil passage until the pistons hit the rubber gasket. Block the hose joint opening [E] during this operation if the caliper half has the opening.
    - Bolt and Nut [F]
    - Oil Passage Sealed by Rubber Gasket [G]
    - Push down [H].

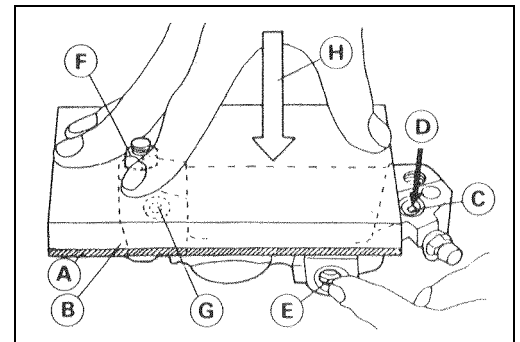

**⚠ WARNING**

**To avoid serious injury, never place your fingers or palm in front of the piston. If you apply compressed air into the caliper, the piston may crush your hand or fingers.**

- Pull out the pistons by hand.
- Remove the dust seals [A] and fluid seals [B].
- Remove the bleed valve [C] and rubber cap [D].
- Repeat the previous step to remove the pistons from the other side of the caliper body.

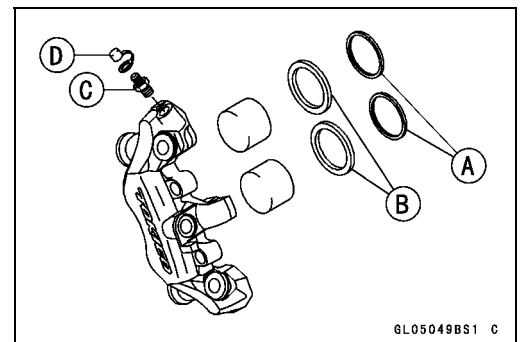

6L05049BS1 C

## 2-60 PERIODIC MAINTENANCE

### Maintenance Procedure

#### NOTE

- If compressed air is not available, do as follows for both calipers coincidentally, with the brake hose connected to the caliper.
- Prepare a container for brake fluid, and perform the work above it.
- Remove the pad spring and pads (see Front Brake Pad Removal in the Brakes chapter).
- Pump the brake lever until the pistons come out of the cylinders, and then disassemble the caliper.

#### Front Caliper Assembly

- Clean the caliper parts except for the pads.

#### CAUTION

For cleaning the parts, use only disc brake fluid, isopropyl alcohol, or ethyl alcohol.

- Install the bleed valve and rubber cap.  
**Torque - Bleed Valve: 7.8 N·m (0.80 kgf·m, 69 in·lb)**
- Replace the fluid seals [A] with new ones.
  - Apply brake fluid to the fluid seals, and install them into the cylinders by hand.
- Replace the dust seals [B] with new ones if they are damaged.
  - Apply brake fluid to the dust seals, and install them into the cylinders by hand.
- Replace the O-ring [A].
- Apply brake fluid to the outside of the pistons, and push them into each cylinder by hand.
- Be sure to install the O-rings.
- Tighten:  
**Torque - Front Caliper Assembly Bolts: 22 N·m (2.2 kgf·m, 16 ft·lb)**
- Install the pads (see Front Brake Pad Installation in the Brakes chapter).
- Wipe up any spilled brake fluid on the caliper with wet cloth.

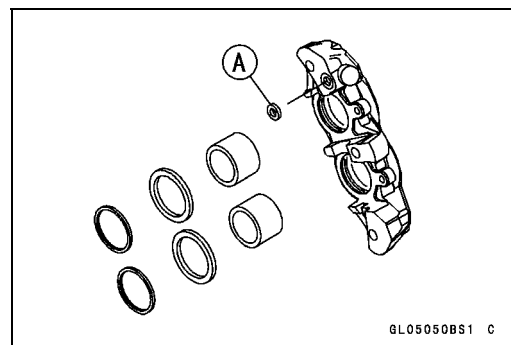
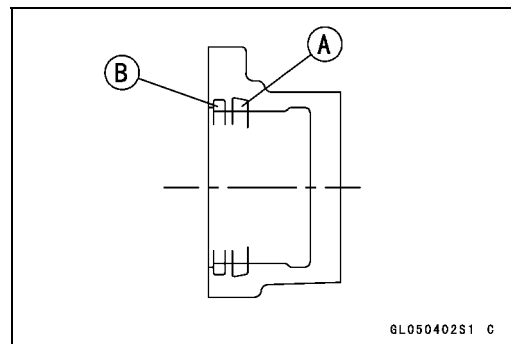

## Maintenance Procedure

### Rear Caliper Disassembly

- Remove the rear caliper (see Rear Caliper Removal in the Brakes chapter).
- Remove the pads and pad spring (see Rear Brake Pad Removal in the Brakes chapter).
- Using compressed air, remove the piston.
  - Cover the caliper opening with a clean, heavy cloth [A].
  - Remove the piston by lightly applying compressed air [B] to where the brake line fits into the caliper.

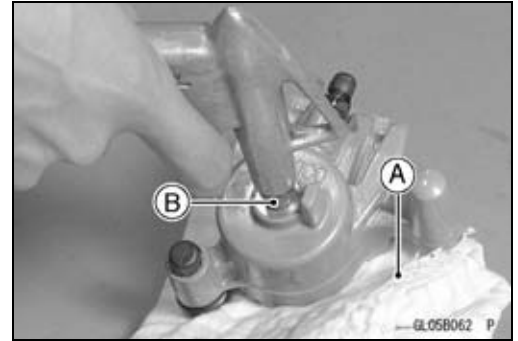

### **⚠ WARNING**

**To avoid serious injury, never place your fingers or palm inside the caliper opening. If you apply compressed air into the caliper, the piston may crush your hand or fingers.**

- Remove the dust seal and fluid seal.
- Remove the bleed valve and rubber cap.

### **NOTE**

- If compressed air is not available, do as follows with the brake hose connected to the caliper.
- Prepare a container for brake fluid, and perform the work above it.
- Remove the pads and pad spring (see Rear Brake Pad Removal in the Brakes chapter).
- Pump the brake pedal to remove the caliper piston.

### Rear Caliper Assembly

- Clean the caliper parts except for the pads.

### **CAUTION**

**For cleaning of the parts, use only disc brake fluid, isopropyl alcohol, or ethyl alcohol.**

- Install the bleed valve and rubber cap.
  - Torque - Bleed Valve: 7.8 N·m (0.80 kgf·m, 69 in·lb)**

- Replace the fluid seal [A] with a new one.
  - Apply brake fluid to the fluid seal, and install it into the cylinder by hand.
- Replace the dust seal [B] with a new one.
  - Apply brake fluid to the dust seal, and install it into the cylinder by hand.

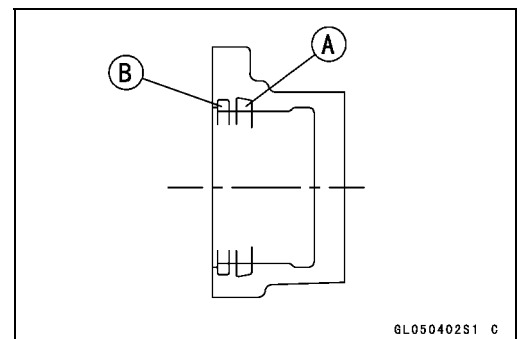

## 2-62 PERIODIC MAINTENANCE

### Maintenance Procedure

- Apply brake fluid to the outside of the piston, and push it into the cylinder by hand.
- Replace the shaft rubber friction boot [A] and dust boot [B].
- Apply a thin coat of PBC (Poly Butyl Cuprysil) grease to the caliper holder shafts [C] and holder holes [D] (PBC is a special high temperature, water-resistance grease).

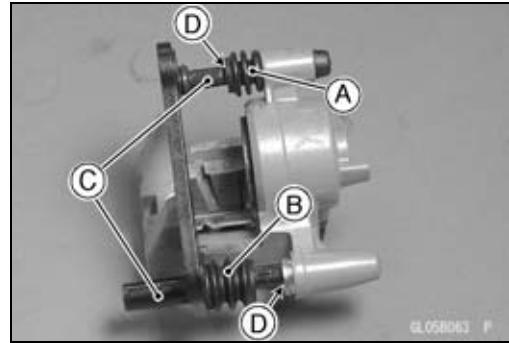

- Install the pad spring [A] in the caliper as shown.
- Install the pads (see Rear Brake Pad Installation in the Brakes chapter).
- Wipe up any spilled brake fluid on the caliper with wet cloth.

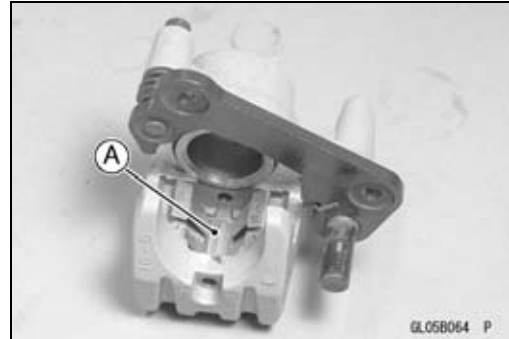

### Spark Plug Replacement

- Remove:
  - Stick Coils (see Stick Coil (Ignition Coil together with Spark Plug Cap) Removal in the Electrical System chapter)
- Remove the spark plug using the 16 mm (0.63 in.) plug wrench [A] vertically.

**Owner's Tool - Spark Plug Wrench, 16 mm: 92110-1132**



- Insert new spark plug in the plug hole, and finger-tighten it first.
- Using the plug wrench [A] vertically, tighten the plug.

#### CAUTION

**The insulator of the spark plug may break if when the wrench is inclined during tightening.**

**Torque - Spark Plugs: 13 N·m (1.3 kgf·m, 113 in·lb)**

- Install the stick coils securely.
- Be sure the stick coils are installed by pulling up it lightly.



# Fuel System (DFI)

## Table of Contents

Exploded View .....	3-3	Crankshaft Sensor (Service Code 21).....	3-63
Specifications .....	3-10	Crankshaft Sensor Removal/Installation.....	3-63
Special Tools and Sealant .....	3-12	Crankshaft Sensor Inspection.....	3-63
DFI Parts Location.....	3-14	Camshaft Position Sensor (Service Code 23).....	3-64
DFI System.....	3-16	Camshaft Position Sensor Removal/Installation.....	3-64
DFI Servicing Precautions .....	3-21	Camshaft Position Sensor Inspection.....	3-64
Troubleshooting the DFI System .....	3-23	Speed Sensor (Service Code 24).....	3-65
Outline .....	3-23	Speed Sensor Removal/Installation .....	3-65
Inquiries to Rider.....	3-27	Speed Sensor Inspection.....	3-65
DFI System Troubleshooting Guide ..	3-30	Input Voltage Inspection.....	3-65
Self-Diagnosis .....	3-38	Output Voltage Inspection.....	3-65
Self-diagnosis Outline.....	3-38	Vehicle-down Sensor (Service Code 31).....	3-67
Self-diagnosis Procedures.....	3-38	Removal.....	3-67
Service Code Clearing Procedures .....	3-39	Installation.....	3-67
Service Code Reading .....	3-41	Inspection.....	3-67
Service Code Erasing .....	3-41	Subthrottle Sensor (Service Code 32).....	3-70
Backups.....	3-43	Subthrottle Sensor Removal/Adjustment.....	3-70
Main Throttle Sensor (Service Code 11).....	3-45	Input Voltage Inspection.....	3-70
Main Throttle Sensor Removal/Adjustment.....	3-45	Output Voltage Inspection.....	3-71
Input Voltage Inspection.....	3-45	Resistance Inspection.....	3-73
Output Voltage Inspection.....	3-46	Exhaust Butterfly Valve Actuator Sensor (Service Code 34) .....	3-74
Resistance Inspection.....	3-48	Exhaust Butterfly Valve Actuator Sensor Inspection .....	3-74
Inlet Air Pressure Sensor (Service Code 12).....	3-49	Immobilizer Amplifier (Service Code 35).....	3-75
Removal.....	3-49	Antenna Resistance Inspection ...	3-75
Installation.....	3-49	Amplifier Input Voltage Inspection .....	3-75
Input Voltage Inspection.....	3-49	Blank Key Detection (Service Code 36).....	3-76
Output Voltage Inspection.....	3-50	User Key Inspection.....	3-76
Inlet Air Temperature Sensor (Service Code 13).....	3-54	Stick Coils #1, #2, #3, #4: (Service Code 51, 52, 53, 54).....	3-78
Removal/Installation.....	3-54	Removal/Installation.....	3-78
Output Voltage Inspection.....	3-54	Input Voltage Inspection.....	3-78
Sensor Resistance Inspection .....	3-55	Subthrottle Valve Actuator (Service Code 62).....	3-80
Water Temperature Sensor (Service Code 14).....	3-57		
Removal/Installation.....	3-57		
Output Voltage Inspection.....	3-57		
Sensor Resistance Inspection .....	3-58		
Atmospheric Pressure Sensor (Service Code 15).....	3-59		
Removal.....	3-59		
Installation.....	3-59		
Input Voltage Inspection.....	3-59		
Output Voltage Inspection.....	3-60		

## 3-2 FUEL SYSTEM (DFI)

---

Subthrottle Valve Actuator Removal .....	3-80	Free Play Inspection .....	3-103
Subthrottle Valve Actuator Inspection .....	3-80	Free Play Adjustment .....	3-103
Resistance Inspection .....	3-80	Cable Installation .....	3-103
Input Voltage Inspection .....	3-81	Cable Lubrication .....	3-103
Exhaust Butterfly Valve Actuator (Service Code 63) .....	3-82	Throttle Body Assy .....	3-104
Exhaust Butterfly Valve Actuator Removal .....	3-82	Idle Speed Inspection .....	3-104
Exhaust Butterfly Valve Actuator Installation .....	3-82	Throttle Bore Cleaning .....	3-104
Exhaust Butterfly Valve Actuator Inspection .....	3-83	Synchronization Inspection .....	3-104
Output Voltage Inspection .....	3-84	Synchronization Adjustment .....	3-104
ECU .....	3-85	Throttle Body Assy Removal .....	3-104
ECU Identification .....	3-85	Throttle Body Assy Installation .....	3-106
ECU Removal .....	3-85	Throttle Body Assy Disassembly ..	3-106
ECU Installation .....	3-86	Throttle Body Assy Assembly .....	3-107
ECU Power Supply Inspection .....	3-86	Nozzle Assy .....	3-108
DFI Power Source .....	3-88	Nozzle Assy Removal .....	3-108
ECU Fuse Removal .....	3-88	Nozzle Assy Installation .....	3-108
ECU Fuse Installation .....	3-88	Nozzle Assy Disassembly .....	3-108
ECU Fuse Inspection .....	3-88	Nozzle Assy Assembly .....	3-109
FI Indicator Light (LED) .....	3-89	Air Cleaner .....	3-111
Light (LED) Inspection .....	3-89	Element Removal .....	3-111
Fuel Line .....	3-90	Element Installation .....	3-111
Fuel Pressure Inspection .....	3-90	Air Cleaner Element Inspection ...	3-111
Fuel Flow Rate Inspection .....	3-91	Air Cleaner Housing Removal .....	3-111
Fuel Pump .....	3-93	Air Cleaner Housing Installation ...	3-112
Fuel Pump Removal .....	3-93	Air Cleaner Housing Disassembly ..	3-113
Fuel Pump Installation .....	3-93	Air Cleaner Housing Assembly ....	3-113
Operation Inspection .....	3-94	Oil Draining .....	3-113
Operating Voltage Inspection .....	3-94	Air Inlet Duct Removal .....	3-113
Fuel Injectors .....	3-96	Air Inlet Duct Installation .....	3-113
Audible Inspection .....	3-96	Fuel Tank .....	3-114
Injector Signal Test .....	3-96	Fuel Tank Removal .....	3-114
Injector Resistance Inspection .....	3-97	Fuel Tank Installation .....	3-116
Injector Unit Test .....	3-98	Fuel Tank and Cap Inspection .....	3-117
Injector Voltage Inspection .....	3-99	Fuel Tank Cleaning .....	3-117
Injector Fuel Line Inspection .....	3-101	Evaporative Emission Control System (California Model) .....	3-118
Throttle Grip and Cables .....	3-103	Parts Removal/Installation .....	3-118
		Hose Inspection .....	3-118
		Separator Inspection .....	3-118
		Separator Operation Test .....	3-119
		Canister Inspection .....	3-119

---

**Exploded View**

---

Dummy Page

# 3-4 FUEL SYSTEM (DFI)

## Exploded View

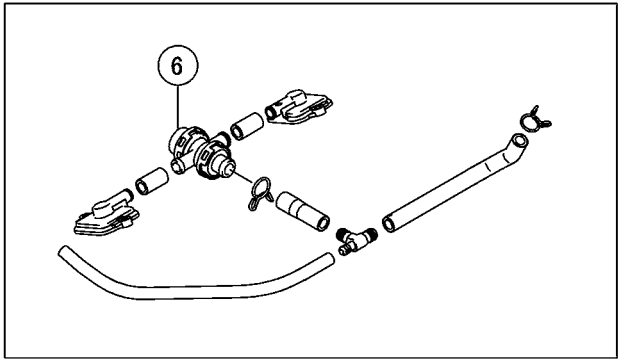
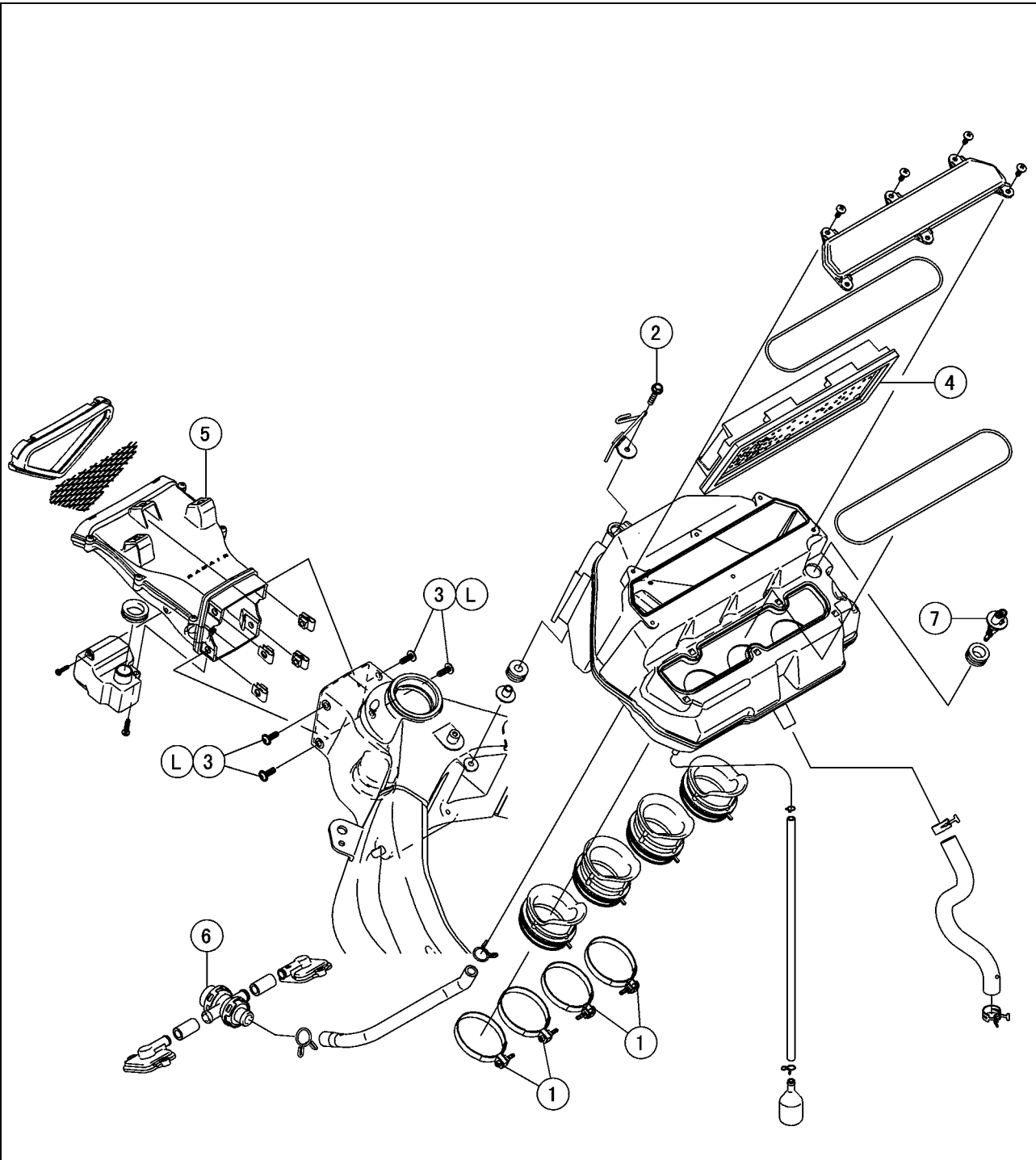

**Exploded View**

No.	Fastener	Torque			Remarks
		N·m	kgf·m	ft·lb	
1	Air Cleaner Housing Clamp Bolts	2.0	0.20	17 in·lb	
2	Air Cleaner Housing Mounting Bolt	6.9	0.70	62 in·lb	
3	Air Inlet Duct Mounting Bolts	6.9	0.70	62 in·lb	L

- 4. Air Cleaner Element
  - 5. Air Inlet Duct
  - 6. Vacuum Switch Valve
  - 7. Inlet Air Temperature Sensor
- L: Apply a non-permanent locking agent.

# 3-6 FUEL SYSTEM (DFI)

## Exploded View

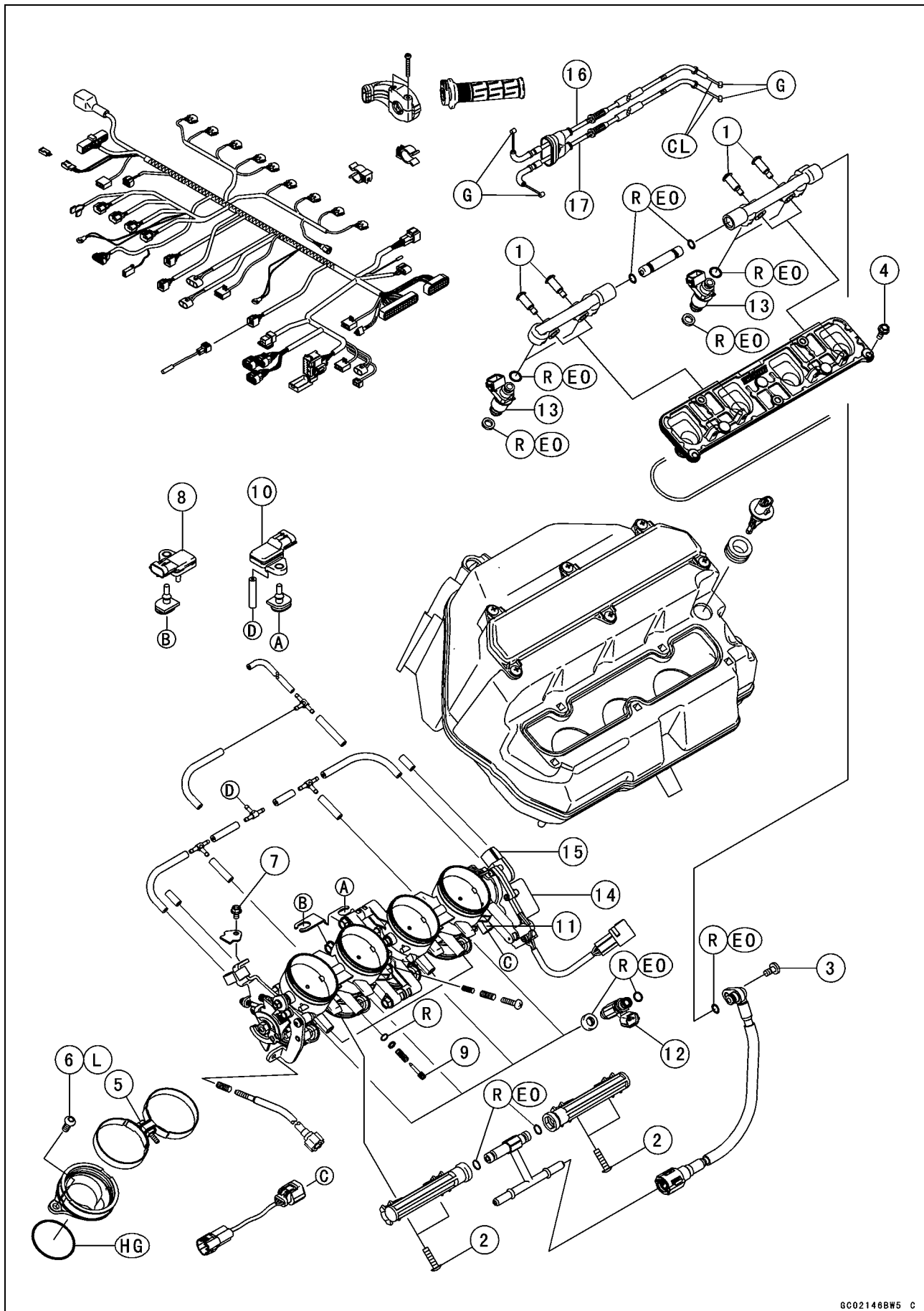

**Exploded View**

No.	Fastener	Torque			Remarks
		N·m	kgf·m	ft·lb	
1	Delivery Pipe Mounting Screws (Nozzle Assy)	3.4	0.35	30 in·lb	
2	Delivery Pipe Mounting Screws (Throttle Body)	3.4	0.35	30 in·lb	
3	Fuel Hose Mounting Screw	4.9	0.50	43 in·lb	
4	Nozzle Assy Mounting Bolts	6.9	0.70	61 in·lb	
5	Throttle Body Assembly Holder Clamp Bolts	3.0	0.30	27 in·lb	
6	Throttle Body Holder Bolts	12	1.2	104 in·lb	L
7	Throttle Cable Holder Bolt	3.9	0.40	35 in·lb	

- 8. Atmospheric Pressure Sensor
- 9. Bypass Screw
- 10. Inlet Air Pressure Sensor
- 11. Main Throttle Valve Sensor
- 12. Primary Fuel Injectors
- 13. Secondary Fuel Injectors
- 14. Subthrottle Valve Actuator
- 15. Subthrottle Valve Sensor
- 16. Throttle Cable (Accelerator)
- 17. Throttle Cable (Decelerator)
- CL: Apply cable lubricant.
- EO: Apply engine oil.
- G: Apply grease.
- HG: Apply high-temperature grease.
- L: Apply a non-permanent locking agent.
- R: Replacement Parts

# 3-8 FUEL SYSTEM (DFI)

## Exploded View

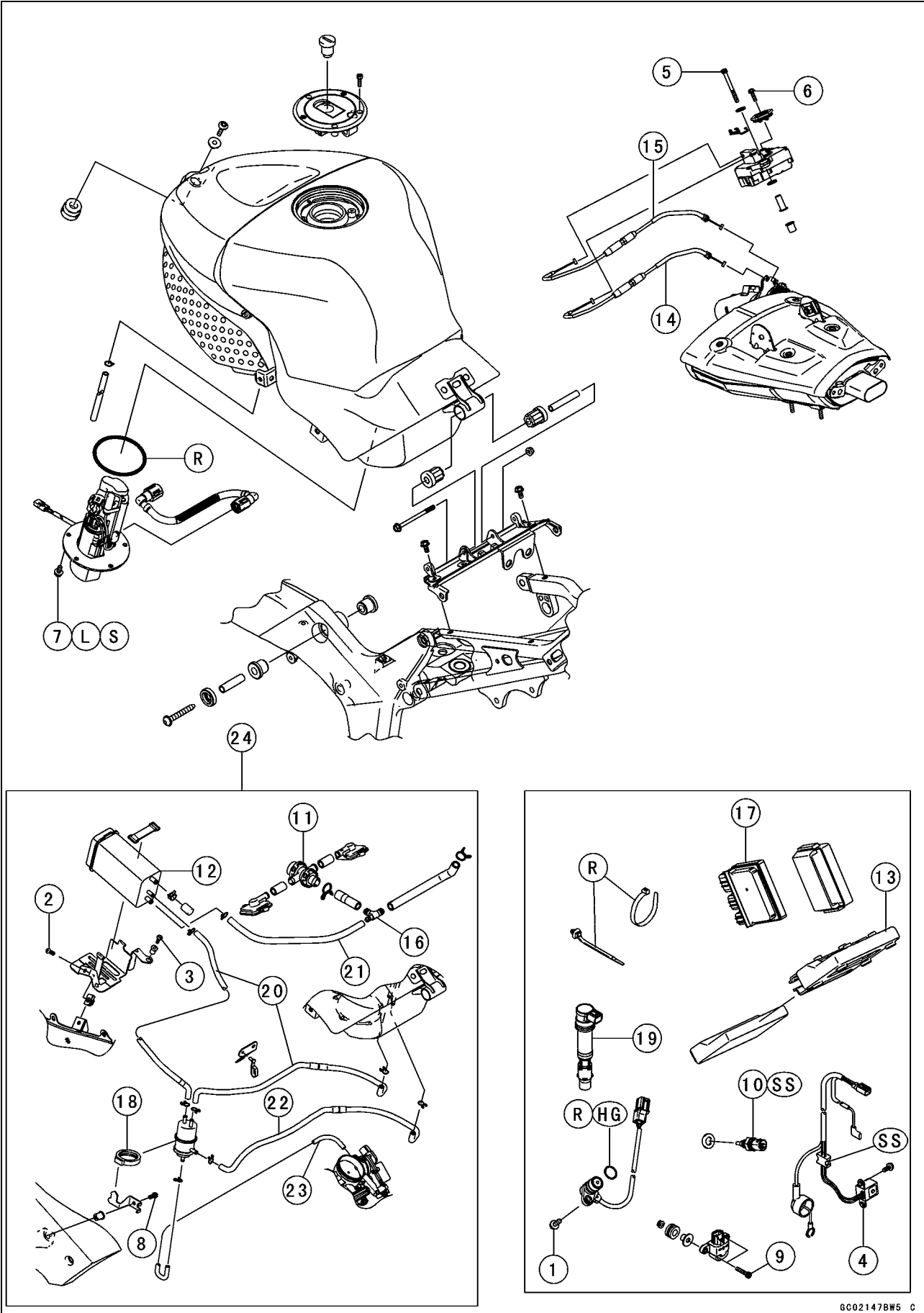

**Exploded View**

No.	Fastener	Torque			Remarks
		N·m	kgf·m	ft·lb	
1	Camshaft Position Sensor Bolt	12	1.2	104 in·lb	
2	Canister Bracket Mounting Bolt (M6)	6.9	0.70	61 in·lb	
3	Canister Bracket Mounting Bolt (M5)	0.4	0.04	4 in·lb	
4	Crankshaft Sensor Bolts	5.9	0.60	52 in·lb	
5	Exhaust Butterfly Valve Actuator Mounting Bolts	6.9	0.70	61 in·lb	
6	Exhaust Butterfly Valve Actuator Pulley Bolt	4.9	0.50	43 in·lb	
7	Fuel Pump Bolts	9.8	1.0	87 in·lb	L, S
8	Separator Bracket Mounting Bolt	0.8	0.08	7 in·lb	
9	Vehicle-down Sensor Bolts	5.9	0.60	52 in·lb	
10	Water Temperature Sensor	25	2.5	18	SS

- 11. Vacuum Switch Valve
- 12. Canister
- 13. ECU
- 14. Exhaust Butterfly Valve Cable (Accelerator)
- 15. Exhaust Butterfly Valve Cable (Decelerator)
- 16. Fitting
- 17. Relay Box
- 18. Separator
- 19. Stick Coil
- 20. Blue Tube
- 21. Green Tube
- 22. Red Tube
- 23. White Tube
- 24. California Model

HG: Apply high-temperature grease.

L: Apply a non-permanent locking agent.

R: Replacement Parts

S: Follow the specific tightening sequence.

SS: Apply silicone sealant.

## 3-10 FUEL SYSTEM (DFI)

### Specifications

Item	Standard
<b>Digital Fuel Injection System</b>	
Idle Speed	1 300 ±50 r/min (rpm)
Throttle Assy:	
Type	Oval type
Bore	φ38 mm (1.5 in.)
Throttle Body Vacuum	27.3 ±1.3 kPa (205 ±10 mmHg)
Bypass Screws	— — —
ECU (Electronic Control Unit):	
Make	Denso
Type	Digital memory type, with built in IC igniter, sealed with resin
Usable Engine Speed	100 ~ 14 960 r/min (rpm)
Fuel Pressure (High Pressure Line):	
Right after Ignition Switch ON, with fuel pump running for 3 seconds with engine idling	304 kPa (3.1 kgf/cm <sup>2</sup> , 44 psi) with fuel pump running 280 kPa (2.9 kgf/cm <sup>2</sup> , 41 psi) with fuel pump stopped 304 kPa (3.1 kgf/cm <sup>2</sup> , 44 psi) with fuel pump running
Fuel Pump:	
Type	In-tank pump (in fuel tank), or Wesco pump (friction pump)
Discharge	67 mL (2.27 US oz) or more for 3 seconds
Primary Fuel Injectors:	
Type	INP-200
Nozzle Type	Fine atomizing type with 12 holes
Resistance	About 11.7 ~ 12.3 Ω at 20°C (68°F)
Secondary Fuel Injectors:	
Nozzle Type	Multihole type with 3 holes
Resistance	About 11.1 ~ 12.3 Ω at 20°C (68°F)
Main Throttle Sensor:	Non-adjustable and non-removable
Input Voltage	DC 4.75 ~ 5.25 V between BL and BR/BK leads
Output Voltage	DC 1.02 ~ 4.62 V between Y/W and BR/BK leads (at idle throttle opening to full throttle opening)
Resistance	4 ~ 6 kΩ
Inlet Air Pressure Sensor/Atmospheric Pressure Sensor:	
Input Voltage	DC 4.75 ~ 5.25 V between BL and BR/BK leads
Output Voltage	DC 3.80 ~ 4.20 V at standard atmospheric pressure (see this text for details)
Inlet Air Temperature Sensor:	
Resistance	2.09 ~ 2.81 kΩ at 20°C (68°F) About 0.322 kΩ at 80°C (176°F)
Output Voltage at ECU	About 2.25 ~ 2.50 V at 20°C (68°F)
Water Temperature Sensor:	
Resistance	see Electrical System chapter
Output Voltage at ECU	About 2.80 ~ 2.97 V at 20°C (68°F)
Speed Sensor:	
Input Voltage at Sensor	About DC 9 ~ 11 V at Ignition Switch ON
Output Voltage at Sensor	About DC 0.05 ~ 0.07 V at Ignition Switch ON and 0 km/h

**Specifications**

Item	Standard
Vehicle-down Sensor: Detection Method Detection Angle Detection Time Output Voltage	Magnetic flux detection method More than 60 ~ 70° for each bank Within 1.0 ~ 1.5 second with sensor arrow mark pointed up: 3.55 ~ 4.45 V with sensor tilted 60 ~ 70° or more: 0.65 ~ 1.35 V
Subthrottle Sensor: Input Voltage Output Voltage  Resistance	Non-adjustable and non-removal DC 4.75 ~ 5.25 V between BL and BR/BK leads DC 1.08 ~ 4.60 V between BR and BR/BK leads (at idle throttle opening to full throttle opening)  4 ~ 6 kΩ
Exhaust Butterfly Valve Actuator Sensor:	
Resistance	4 ~ 6 kΩ
Immobilizer Amplifier:	
Antenna Resistance	About 0.6 ~ 0.9 Ω
Exhaust Butterfly Valve Actuator:	
Output Voltage	3.46 ~ 3.76 V
Subthrottle Valve Actuator:	
Resistance	About 5.5 ~ 7.5 Ω
Input Voltage	About DC 8.5 ~ 10.5 V
<b>Throttle Grip and Cables</b>	
Throttle Grip Free Play	2 ~ 3 mm (0.08 ~ 0.12 in.)

# 3-12 FUEL SYSTEM (DFI)

## Special Tools and Sealant

**Oil Pressure Gauge, 5 kgf/cm<sup>2</sup>:**  
57001-125

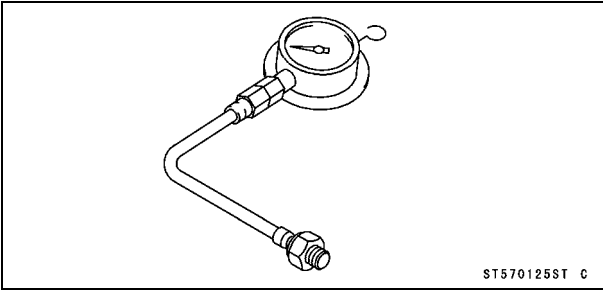

**Needle Adapter Set:**  
57001-1457

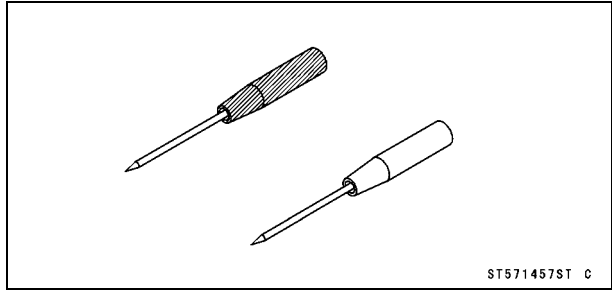

**Fork Oil Level Gauge:**  
57001-1290

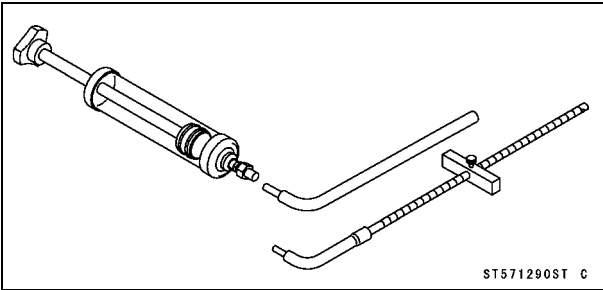

**Throttle Sensor Setting Adapter:**  
57001-1538

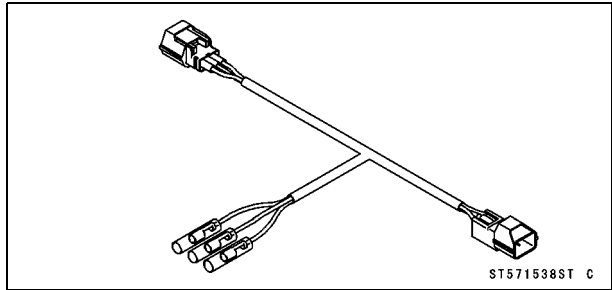

**Hand Tester:**  
57001-1394

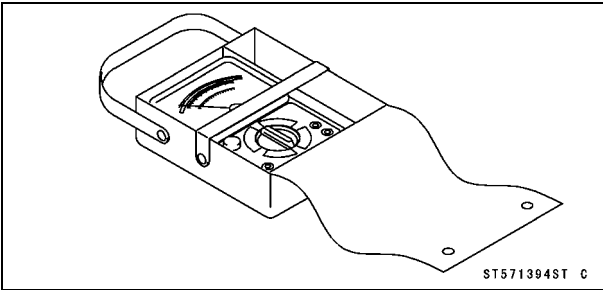

**Sensor Harness Adapter:**  
57001-1561

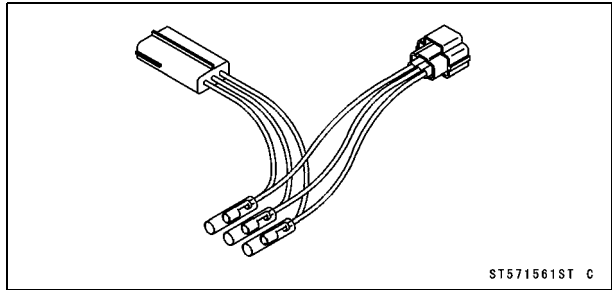

**Throttle Sensor Setting Adapter #1:**  
57001-1400

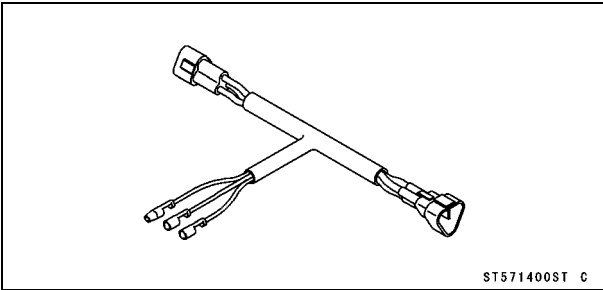

**Fuel Pressure Gauge Adapter:**  
57001-1593

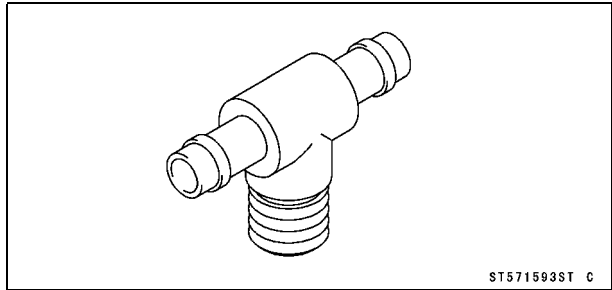

**Peak Voltage Adapter:**  
57001-1415

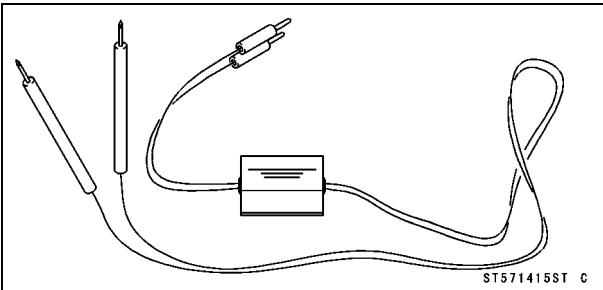

**Fuel Hose:**  
57001-1607

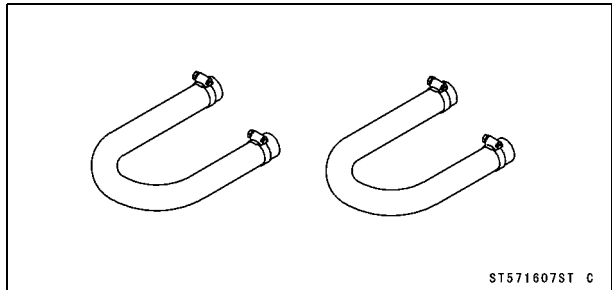

**Special Tools and Sealant**

**Speed Sensor Measuring Adapter:  
57001-1635**

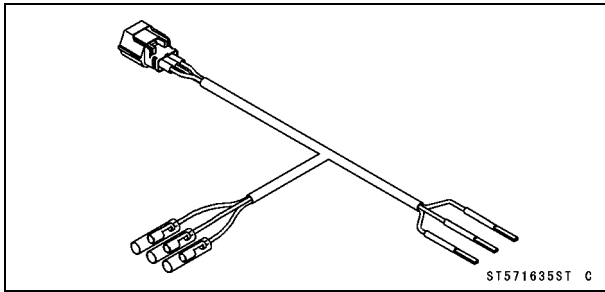

**Kawasaki Bond (Silicone Sealant):  
56019-120**

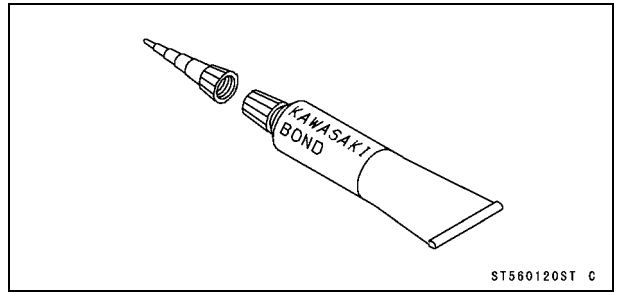

## 3-14 FUEL SYSTEM (DFI)

### DFI Parts Location

Subthrottle Sensor [A]  
Subthrottle Valve Actuator [B]  
Fuel Injectors (Primary) #1, #2, #3, #4 [C]

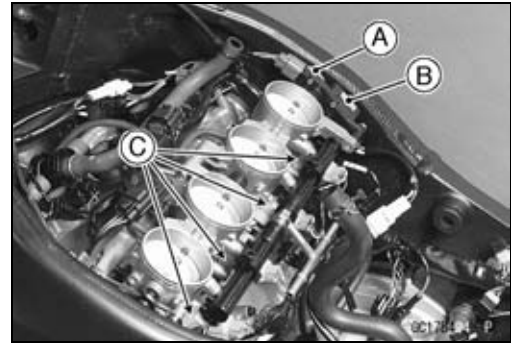

Water Temperature Sensor [A]  
Main Throttle Sensor [B]  
Inlet Air Pressure Sensor [C]  
Stick Coils #1, #2, #3, #4 [D]  
Subthrottle Valve Actuator [E]  
Subthrottle Sensor [F]  
Atmospheric Pressure Sensor [G]

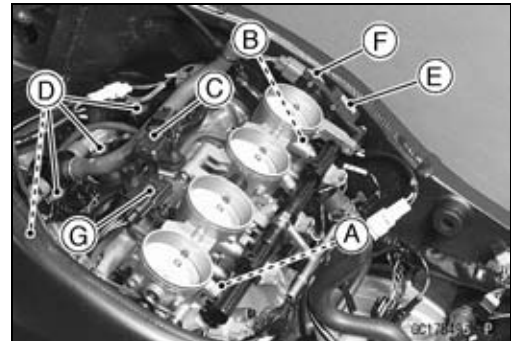

Battery [A]  
Relay Box [B]  
Exhaust Butterfly Valve Actuator [C]  
ECU (Electronic Control Unit) [D]

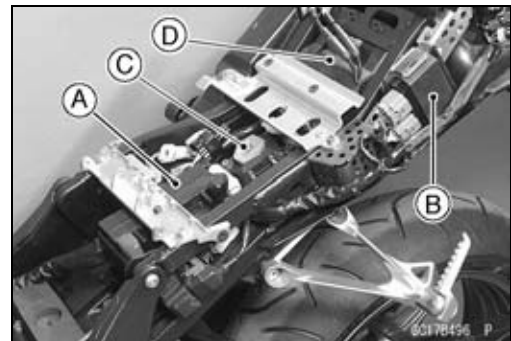

Self-diagnosis Terminal [A]  
Kawasaki Diagnosis System (KDS) Connector [B]  
Vehicle-down Sensor [C]

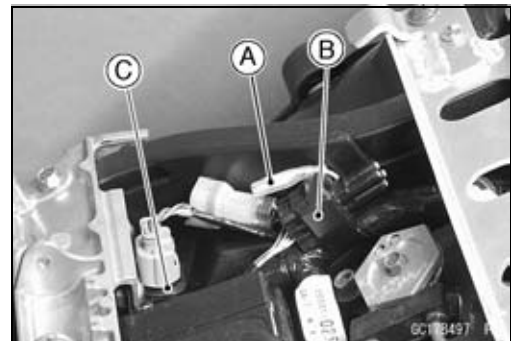

Inlet Air Temperature Sensor [A]



**DFI Parts Location**

Camshaft Position Sensor [A]  
Crankshaft Sensor [B]

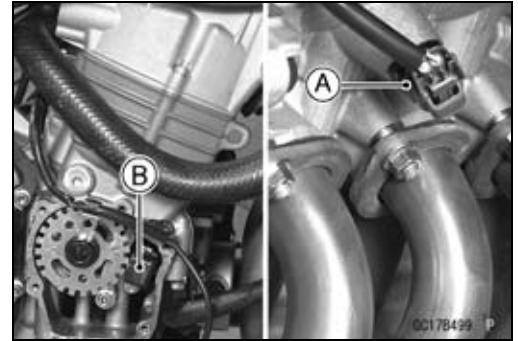

Speed Sensor [A]



Neutral Switch [A]



Ignition Key (Transponder) [A]  
Ignition Switch [B]  
Immobilizer Antenna [C]  
Immobilizer Amplifier [D]

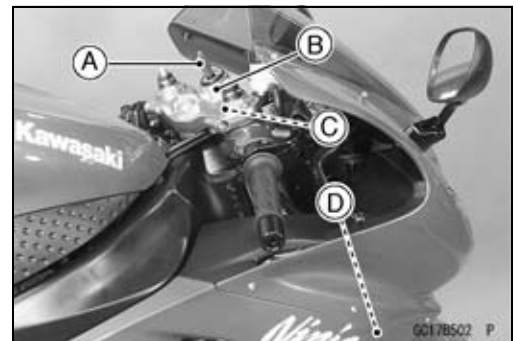

Immobilizer Amplifier [A]



# 3-16 FUEL SYSTEM (DFI)

## DFI System

### DFI System

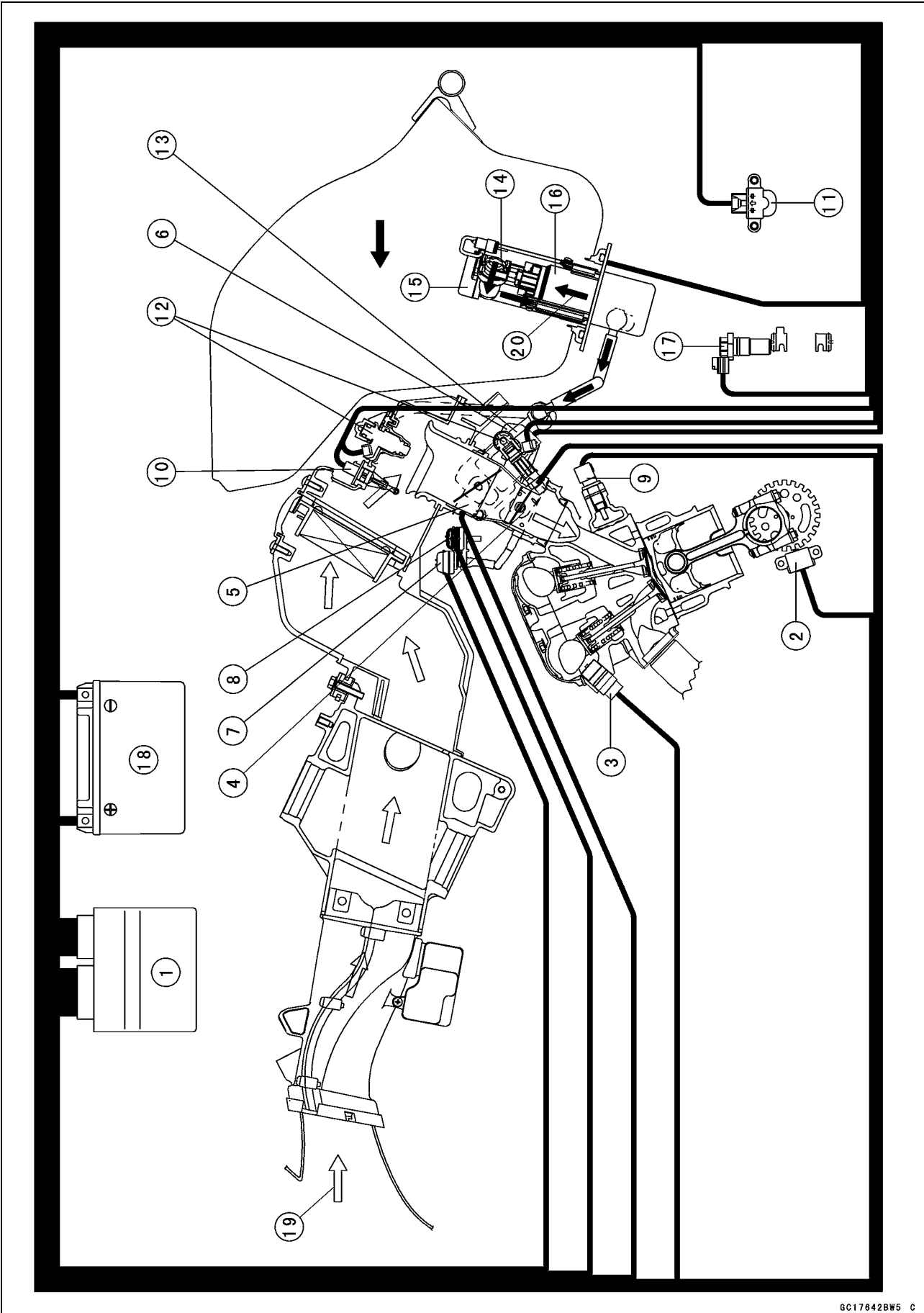

### DFI System

---

1. ECU (Electrical Control Unit)
2. Crankshaft Sensor
3. Camshaft Position Sensor
4. Main Throttle Sensor
5. Subthrottle Sensor
6. Subthrottle Valve Actuator
7. Inlet Air Pressure Sensor
8. Atmospheric Pressure Sensor
9. Water Temperature Sensor
10. Inlet Air Temperature Sensor
11. Vehicle-down Sensor
12. Fuel Injectors
13. Delivery Pipe
14. Pressure Regulator
15. Fuel Filter
16. Fuel Pump
17. Speed Sensor
18. Battery
19. Air Flow
20. Fuel Flow

# 3-18 FUEL SYSTEM (DFI)

## DFI System

### DFI System Wiring Diagram

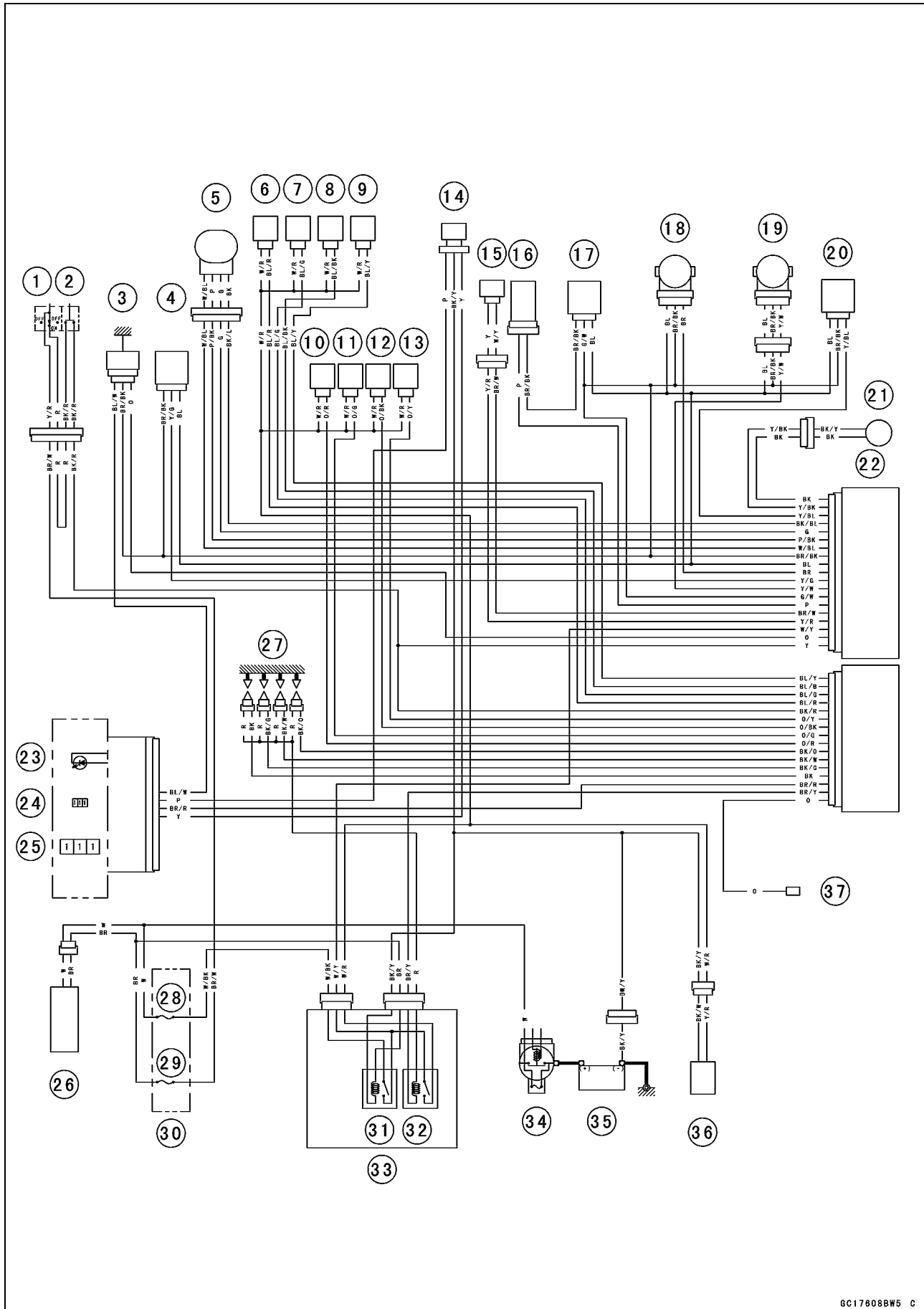

---

**DFI System**

---

**Part Name**

1. Engine Stop Switch
2. Starter Button
3. Water Temperature Sensor
4. Vehicle-down Sensor
5. Subthrottle Valve Actuator
6. Primary Fuel Injector #1
7. Primary Fuel Injector #2
8. Primary Fuel Injector #3
9. Primary Fuel Injector #4
10. Secondary Fuel Injector #1
11. Secondary Fuel Injector #2
12. Secondary Fuel Injector #3
13. Secondary Fuel Injector #4
14. Speed Sensor
15. Camshaft Position Sensor
16. Inlet Air Temperature Sensor
17. Atmospheric Pressure Sensor
18. Subthrottle Sensor
19. Main Throttle Sensor
20. Inlet Air Pressure Sensor
21. Crankshaft Sensor
22. ECU (Electronic Control Unit)
23. FI Warning Indicator LED
24. Water Temperature Gauge
25. Speedometer
26. Ignition Switch
27. Stick Coil #1, #2, #3, #4
28. ECU Fuse 15 A
29. Ignition Fuse 10 A
30. Fuse Box
31. ECU Main Relay
32. Fuel Pump Relay
33. Relay Box
34. Main Fuse 30 A
35. Battery
36. Fuel Pump
37. Self-diagnosis Terminal

# 3-20 FUEL SYSTEM (DFI)

## DFI System

### Terminal Numbers of ECU Connectors

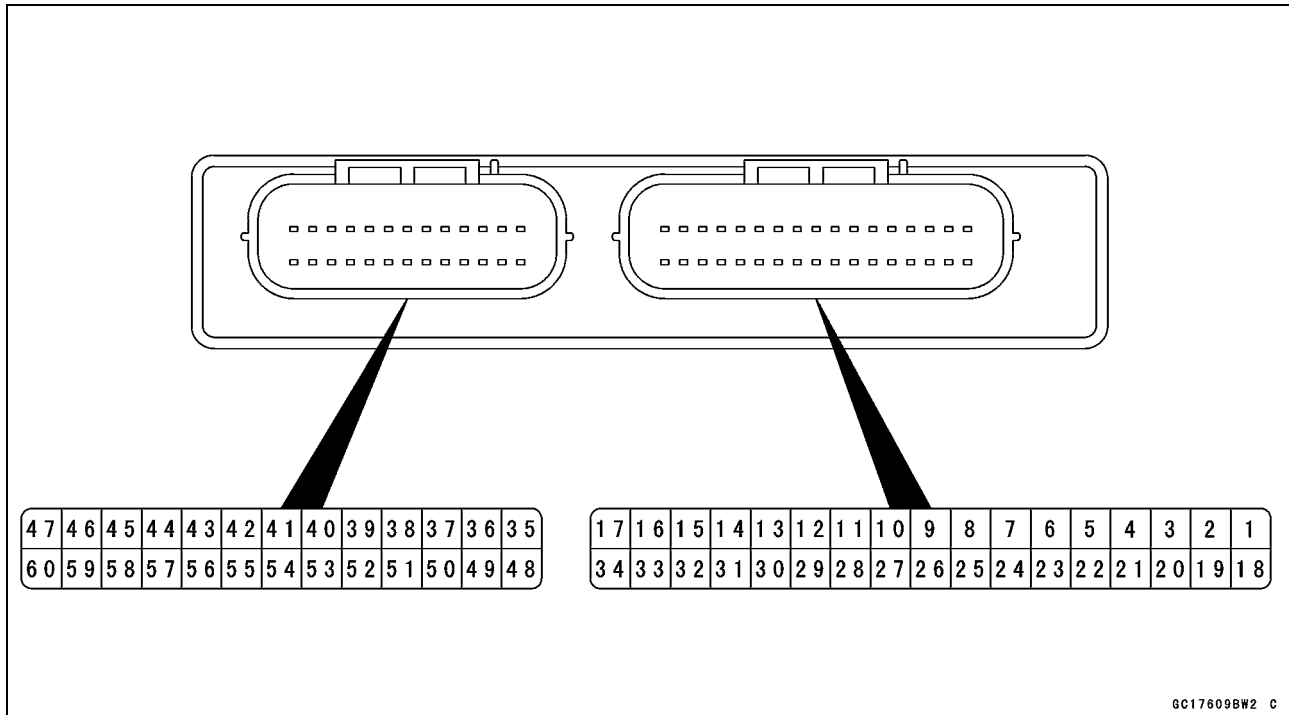

### Terminal Names

- |   |   |
|---|---|
| <ol style="list-style-type: none"> <li>1. Subthrottle Valve Actuator Output Signal 2</li> <li>2. Subthrottle Valve Actuator Output Signal 1</li> <li>3. Exhaust Butterfly Valve Actuator (-)</li> <li>4. Exhaust Butterfly Valve Actuator (+)</li> <li>5. Exhaust Butterfly Valve Sensor</li> <li>6. Speed Sensor Output Signal</li> <li>7. Main Throttle Sensor Output Signal</li> <li>8. Inlet Air Pressure Sensor Output Signal</li> <li>9. Water Temperature Sensor Output Signal</li> <li>10. Power Supply to Sensors</li> <li>11. Vehicle-down Sensor Output Signal</li> <li>12. Camshaft Position Sensor (+) Output Signal</li> <li>13. Crankshaft Sensor (+) Output Signal</li> <li>14. Immobilizer Communication Line</li> <li>15. Immobilizer Communication Line</li> <li>16. Power Supply to ECU (from ECU Main Relay)</li> <li>17. Power Supply to ECU (from Battery)</li> <li>18. Subthrottle Valve Actuator Output Signal 4</li> <li>19. Subthrottle Valve Actuator Output Signal 3</li> <li>20. Unused</li> <li>21. Unused</li> <li>22. Unused</li> <li>23. Unused</li> <li>24. Subthrottle Sensor Output Signal</li> <li>25. Atmospheric Pressure Sensor Output Signal</li> <li>26. Inlet Air Temperature Sensor Output Signal</li> <li>27. Unused</li> <li>28. Ground to Sensors</li> <li>29. Camshaft Position Sensor (-) Output Signal</li> <li>30. Crankshaft Sensor (-) Output Signal</li> </ol> | <ol style="list-style-type: none"> <li>31. Immobilizer Communication Line</li> <li>32. External Diagnosis System Signal</li> <li>33. Unused</li> <li>34. Ground to ECU</li> <li>35. Engine Stop Switch Output Signal</li> <li>36. Starter Lockout Switch Output Signal</li> <li>37. Starter Button Output Signal</li> <li>38. Fuel Pump Relay Output Signal</li> <li>39. Unused</li> <li>40. Radiator Fan Signal</li> <li>41. Secondary Fuel Injector #2 Output Signal</li> <li>42. Secondary Fuel Injector #1 Output Signal</li> <li>43. Primary Fuel Injector #2 Output Signal</li> <li>44. Primary Fuel Injector #1 Output Signal</li> <li>45. Stick Coil #3 Output Signal</li> <li>46. Stick Coil #2 Output Signal</li> <li>47. Stick Coil #1 Output Signal</li> <li>48. Side Stand Switch Signal</li> <li>49. Self-diagnosis Terminal</li> <li>50. External Communication Line (Mode Switch)</li> <li>51. Tachometer Output Signal</li> <li>52. FI Indicator LED Light</li> <li>53. Unused</li> <li>54. Secondary Fuel Injector #4 Output Signal</li> <li>55. Secondary Fuel Injector #3 Output Signal</li> <li>56. Primary Fuel Injector #4 Output Signal</li> <li>57. Primary Fuel Injector #3 Output Signal</li> <li>58. Ground for Fuel System</li> <li>59. Ground for Ignition System</li> <li>60. Stick Coil #4 Output Signal</li> </ol> |
|---|---|

---

**DFI Servicing Precautions**

---

There are a number of important precautions that should be followed servicing the DFI system.

- This DFI system is designed to be used with a 12 V sealed battery as its power source. Do not use any other battery except for a 12 V sealed battery as a power source.
- Do not reverse the battery cable connections. This will damage the ECU.
- To prevent damage to the DFI parts, do not disconnect the battery cables or any other electrical connections when the ignition switch is ON, or while the engine is running.
- Take care not to short the leads that are directly connected to the battery positive (+) terminal to the chassis ground.
- When charging, remove the battery from the motorcycle. This is to prevent ECU damage by excessive voltage.
- Whenever the DFI electrical connections are to be disconnected, first turn off the ignition switch. Conversely, make sure that all the DFI electrical connections are firmly reconnected before starting the engine.
- Do not turn the ignition switch ON while any of the DFI electrical connectors are disconnected. The ECU memorizes service codes.
- Do not spray water on the electrical parts, DFI parts, connectors, leads, and wiring.
- If a transceiver is installed on the motorcycle, make sure that the operation of the DFI system is not influenced by electric wave radiated from the antenna. Check operation of the system with the engine at idle. Locate the antenna as far as possible away from the ECU.
- When any fuel hose is disconnected, do not turn on the ignition switch. Otherwise, the fuel pump will operate and fuel will spout from the fuel hose.
- Do not operate the fuel pump if the pump is completely dry. This is to prevent pump seizure.
- Before removing the fuel system parts, blow the outer surfaces of these parts clean with compressed air.
- When any fuel hose is disconnected, fuel may spout out by residual pressure in the fuel line. Cover the hose joint with a piece of clean cloth to prevent fuel spillage.
- When installing the fuel hoses, avoid sharp bending, kinking, flattening or twisting, and route the fuel hoses with a minimum of bending so that the fuel flow will not be obstructed.
- Route the hoses according to Cable, Wire, and Hose Routing section in the Appendix chapter.
- Replace the fuel hose if it has been sharply bent or kinked.

## 3-22 FUEL SYSTEM (DFI)

### DFI Servicing Precautions

- The motorcycle is not properly handled, the high pressure inside the fuel line can cause fuel to leak or the hose to burst. Bend and twist the fuel hose while examining it.
- ★Replace the hose if any cracks or bulges are noticed.

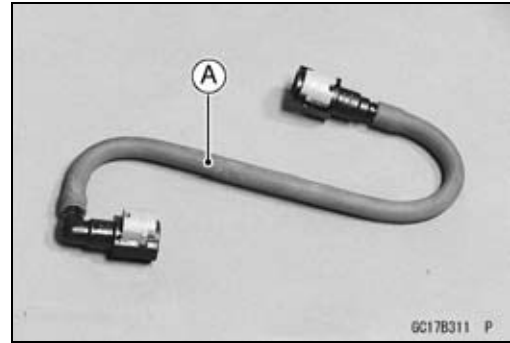

- To maintain the correct fuel/air mixture (F/A), there must be no inlet air leaks in the DFI system. Be sure to install the oil filler plug [A] after filling the engine oil.  
Clutch Cover [B]

**Torque - Oil Filler Plug: 1.5 N·m (0.15 kgf·m, 13 in·lb)**

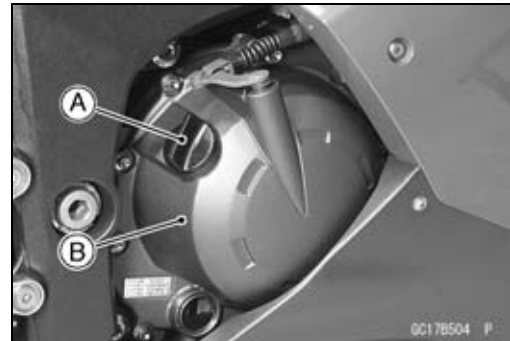

## Troubleshooting the DFI System

### Outline

When an abnormality in the system occurs, the FI indicator light (LED) goes on to alert the rider on the meter panel. In addition, the condition of the problem is stored in the memory of the ECU (Electronic Control Unit). With the engine stopped and turned in the self-diagnosis mode, the service code [A] is indicated by the number of times the FI indicator light (LED) blinks.

When due to a malfunction, the FI indicator light (LED) remains lit, ask the rider about the conditions [B] under which the problem occurred and try to determine the cause [C]. Don't rely solely on the DFI self-diagnosis function, use common sense; first conduct a pre-diagnosis inspection, check the ECU for ground and power supply, the fuel line for no fuel leaks, and for correct pressure. The pre-diagnosis items are not indicated by the FI indicator light (LED).

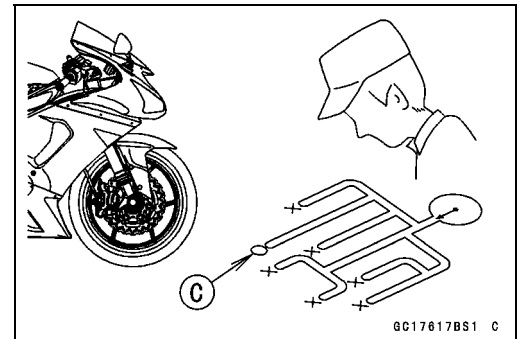
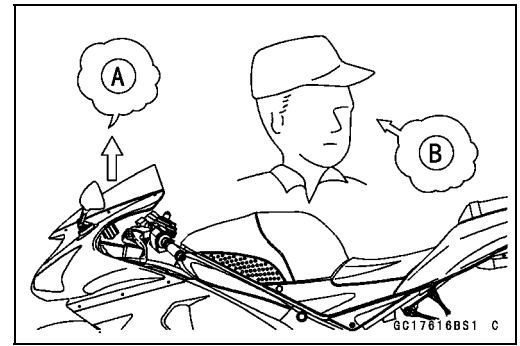

Even when the DFI system is operating normally, the FI indicator light (LED) [A] may light up under strong electrical interference. No remedy needed. Turn the ignition switch OFF to stop the indicator light.

When the FI indicator light (LED) goes on and the motorcycle is brought in for repair, check the service codes.

When the repair has been done, the light (LED) doesn't go on. But the service codes stored in memory are not erased to preserve the problem history, and the light (LED) can display the codes in the self-diagnosis mode. The problem history is referred when solving unstable problems.



Much of the DFI system troubleshooting work consists of confirming continuity of the wiring. The DFI parts are assembled and adjusted with precision, and it is impossible to disassemble or repair them.

- When checking the DFI parts, use a digital meter which can be read two decimal place voltage or resistance.
- Remove:
  - Rear Seat (see Rear Seat Removal in the Frame chapter)
  - Front Seat (see Front Seat Removal in the Frame chapter)
  - Seat Cover (see Seat Cover Removal in the Frame chapter)
- The DFI part connectors have seals, including the ECU. When measuring the input or output voltage with the connector joined, use the needle adapter set. Insert the needle adapter inside the seal until the needle adapter reaches the terminal.

**Special Tool - Needle Adapter Set: 57001-1457**

## 3-24 FUEL SYSTEM (DFI)

### Troubleshooting the DFI System

○After measurement, remove the needle adapters and apply silicone sealant to the seals [A] of the connector [B] for waterproofing.

**Sealant - Kawasaki Bond (Silicone Sealant): 56019-120**

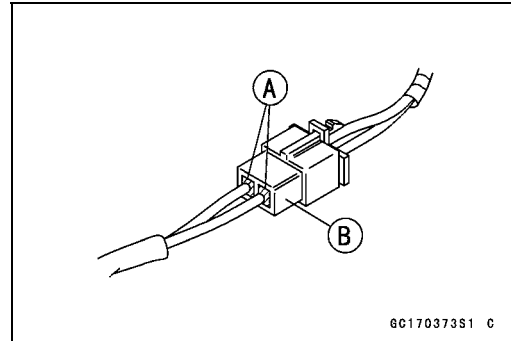

- Always check battery condition before replacing the DFI parts. A fully charged battery is a must for conducting accurate tests of the DFI system.
- Trouble may involve one or in some cases all items. Never replace a defective part without determining what CAUSED the problem. If the problem was caused by some other item or items, they too must be repaired or replaced, or the new replacement part will soon fail again.
- Measure coil winding resistance when the DFI part is cold (at room temperature).
- Do not adjust or remove the throttle sensor.
- Do not directly connect a 12 V battery to a fuel injector. Insert a resistor (5 ~ 7  $\Omega$ ) or a bulb (12 V  $\times$  3 ~ 3.4 W) in series between the battery and the injector.
- The DFI parts have been adjusted and set with precision. Therefore, they should be handled carefully, never strike sharply, as with a hammer, or allowed to drop on a hard surface. Such a shock to the parts can damage them.
- Check wiring and connections from the ECU connector to the suspected faulty DFI parts, using the hand tester (special tool, analog tester) rather than a digital tester.

**Special Tool - Hand Tester: 57001-1394**

- Make sure all connectors in the circuit are clean and tight, and examine wires for signs of burning, fraying, etc. Deteriorated leads and bad connections can cause reappearance of problems and unstable operation of the DFI system.
- ★ If any wiring is deteriorated, replace the wiring.

## Troubleshooting the DFI System

- Pull each connector [A] apart and inspect it for corrosion, dirt, and damage.
- ★ If the connector is corroded or dirty, clean it carefully. If it is damaged, replace it. Connect the connectors securely.
- Check the wiring for continuity.
- Use the wiring diagram to find the ends of the lead which is suspected of being a problem.
- Connect the hand tester between the ends of the leads.
- Set the tester to the  $\times 1 \Omega$  range, and read the tester.
- ★ If the tester does not read  $0 \Omega$ , the lead is defective. Replace the lead or the main harness or the sub harness.

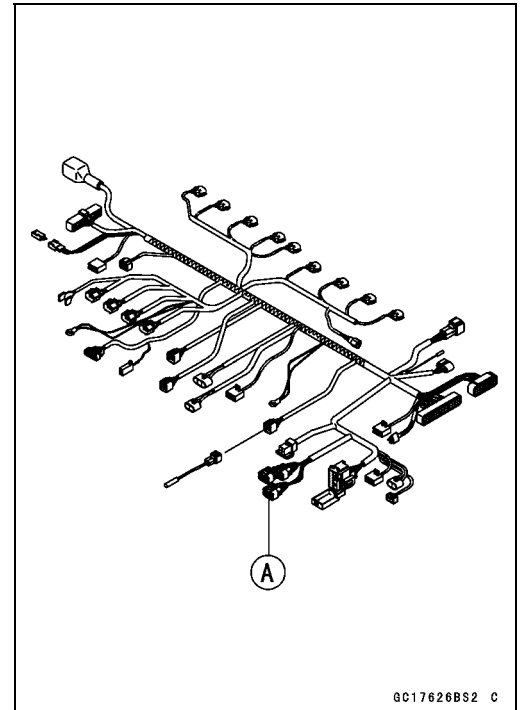

- If both ends of a harness [A] are far apart, ground [B] the one end [C], using a jumper lead [D] and check the continuity between the end [E] and the ground [F]. This enables to check a long harness for continuity. If the harness is open, repair or replace the harness.

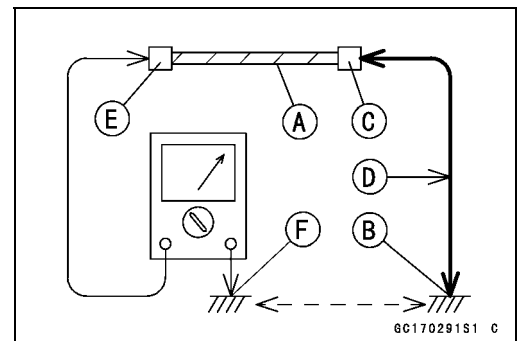

- When checking a harness [A] for short circuit, open one end [B] and check the continuity between the other end [C] and ground [D]. If there is continuity, the harness has a short circuit to ground, and it must be repaired or replaced.

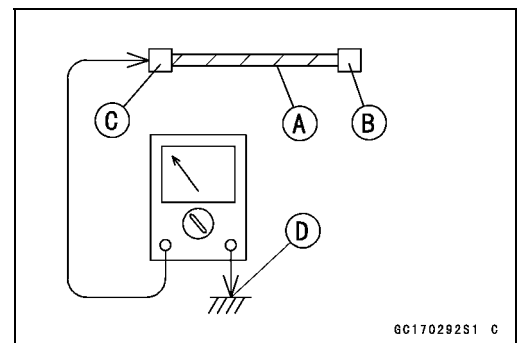

# 3-26 FUEL SYSTEM (DFI)

## Troubleshooting the DFI System

- Narrow down suspicious locations by repeating the continuity tests from the ECU connectors.
- ★ If no abnormality is found in the wiring or connectors, the DFI parts are the next likely suspects. Check the part, starting with input and output voltages. However, there is no way to check the ECU itself.
- ★ If an abnormality is found, replace the affected DFI part.
- ★ If no abnormality is found in the wiring, connectors, and DFI parts, replace the ECU.
- The diagnosis flow chart illustrates (Page 3-27) the above procedures.
- After inspection, be sure to connect all the DFI electrical connectors. Do not turn the ignition switch ON while the DFI electrical connectors and ignition system connectors are disconnected. Otherwise, the ECU memorizes service codes as open circuit.

### ○ Lead Color Codes:

BK: Black	G: Green	P: Pink
BL: Blue	GY: Gray	PU: Purple
BR: Brown	LB: Light Blue	R: Red
CH: Chocolate	LG: Light Green	W: White
DG: Dark Green	O: Orange	Y: Yellow

### ○ Electrical Connectors:

Female Connectors [A]

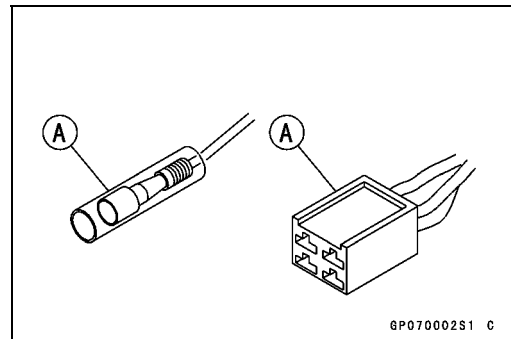

Male Connectors [B]

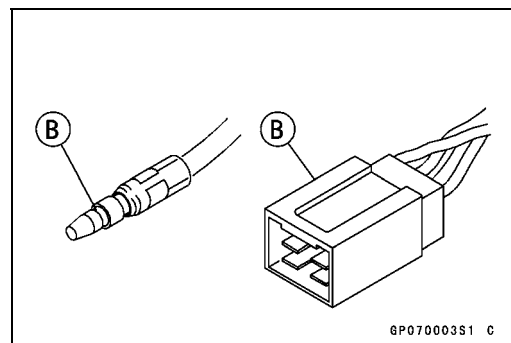

Troubleshooting the DFI System

DFI Diagnosis Flow Chart

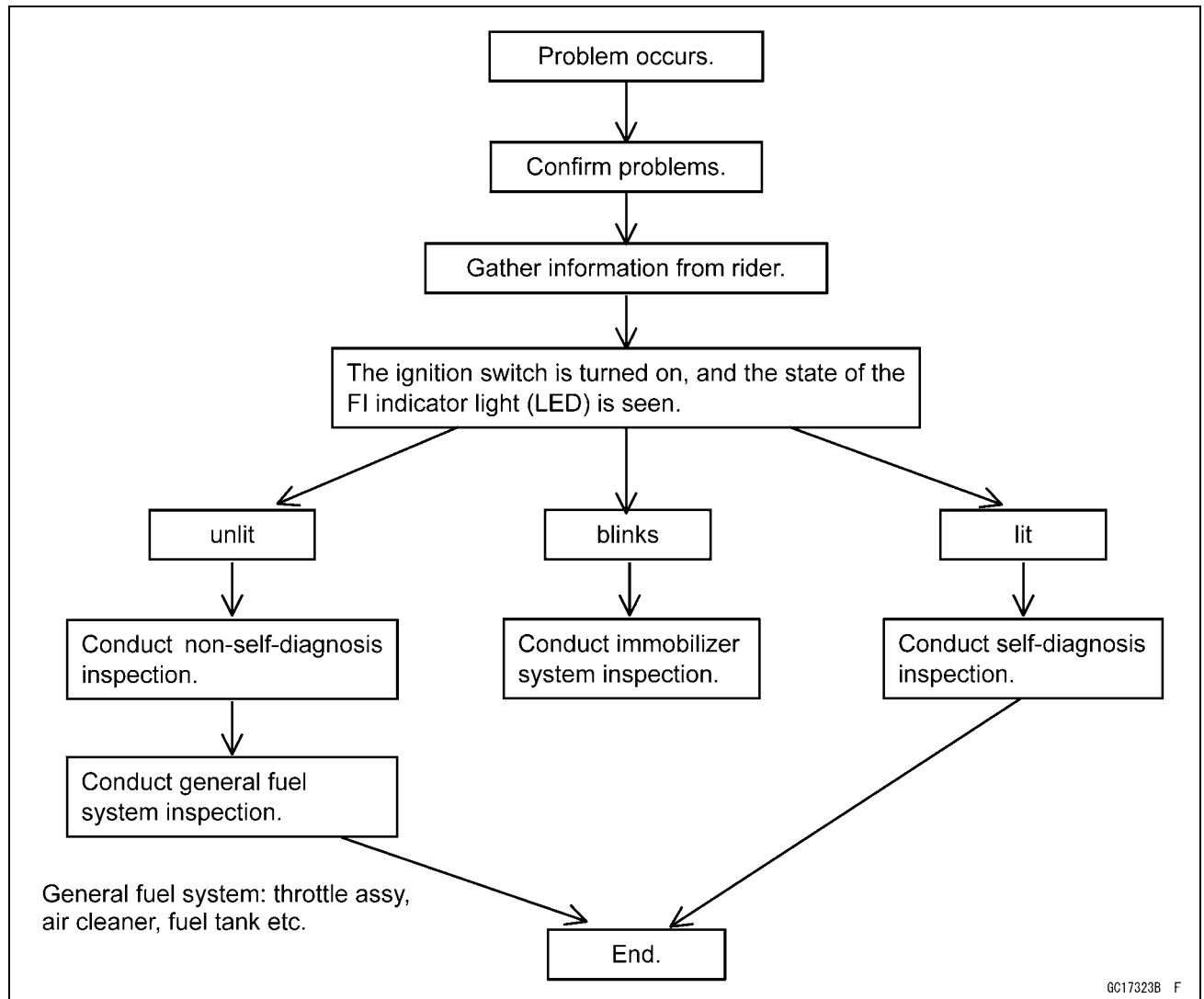

**Inquiries to Rider**

- Each rider reacts to problems in different ways, so it is important to confirm what kind of symptoms the rider has encountered.
- Try to find out exactly what problem occurred under exactly what conditions by asking the rider; knowing this information may help you reproduce the problem.
- The diagnosis sheet will help prevent you from overlooking any areas, and will help you decide if it is a DFI system problem, or a general engine problem.

### 3-28 FUEL SYSTEM (DFI)

#### Troubleshooting the DFI System

#### Sample Diagnosis Sheet

<b>Rider name:</b>	<b>Registration No. (license plate No.):</b>	<b>Year of initial registration:</b>
<b>Model:</b>	<b>Engine No.:</b>	<b>Frame No.:</b>
<b>Date problem occurred:</b>		<b>Mileage:</b>
<b>Environment when problem occurred.</b>		
Weather	<input type="checkbox"/> fine, <input type="checkbox"/> cloudy, <input type="checkbox"/> rain, <input type="checkbox"/> snow, <input type="checkbox"/> always, <input type="checkbox"/> other:	
Temperature	<input type="checkbox"/> hot, <input type="checkbox"/> warm, <input type="checkbox"/> cold, <input type="checkbox"/> very cold, <input type="checkbox"/> always, <input type="checkbox"/> other:	
Problem frequency	<input type="checkbox"/> chronic, <input type="checkbox"/> often, <input type="checkbox"/> once	
Road	<input type="checkbox"/> street, <input type="checkbox"/> highway, <input type="checkbox"/> mountain road ( <input type="checkbox"/> uphill, <input type="checkbox"/> downhill), <input type="checkbox"/> bumpy, <input type="checkbox"/> pebble	
Altitude	<input type="checkbox"/> normal, <input type="checkbox"/> high (about 1 000 m or more)	
<b>Motorcycle conditions when problem occurred.</b>		
FI indicator light (LED)	<input type="checkbox"/> lights up immediately after ignition switch ON, and goes off after 1 ~ 2 seconds (normal).	
	<input type="checkbox"/> lights up immediately after ignition switch ON, and stays on (DFI problem).	
	<input type="checkbox"/> lights up immediately after ignition switch ON, and blinks (immobilizer system problem).	
	<input type="checkbox"/> lights up immediately after ignition switch ON, but goes off after about 10 seconds (DFI problem).	
	<input type="checkbox"/> unlights (light (LED), ECU or its wiring fault).	
	<input type="checkbox"/> sometimes lights up (probably wiring fault).	
Starting difficulty	<input type="checkbox"/> starter motor not rotating.	
	<input type="checkbox"/> starter motor rotating but engine doesn't turn over.	
	<input type="checkbox"/> starter motor and engine don't turn over.	
	<input type="checkbox"/> no fuel flow ( <input type="checkbox"/> no fuel in tank, <input type="checkbox"/> no fuel pump sound).	
	<input type="checkbox"/> no spark.	
	<input type="checkbox"/> choke lever is not pulled fully when using the lever (pull it fully when using).	
	<input type="checkbox"/> other:	
Engine stalls	<input type="checkbox"/> right after starting.	
	<input type="checkbox"/> when opening throttle grip.	
	<input type="checkbox"/> when closing throttle grip.	
	<input type="checkbox"/> when moving off.	
	<input type="checkbox"/> when stopping the motorcycle.	
	<input type="checkbox"/> when cruising.	
	<input type="checkbox"/> other:	

**Troubleshooting the DFI System**

Poor running at low speed	<input type="checkbox"/> very low idle speed, <input type="checkbox"/> very high idle speed, <input type="checkbox"/> rough idle speed.
	<input type="checkbox"/> battery voltage is low (charge the battery).
	<input type="checkbox"/> spark plug loose (tighten it).
	<input type="checkbox"/> spark plug dirty, broken, or gap maladjusted (remedy it).
	<input type="checkbox"/> backfiring.
	<input type="checkbox"/> afterfiring.
	<input type="checkbox"/> hesitation when acceleration.
	<input type="checkbox"/> engine oil viscosity too high.
	<input type="checkbox"/> brake dragging.
	<input type="checkbox"/> engine overheating.
	<input type="checkbox"/> clutch slipping.
	<input type="checkbox"/> other:
Poor running or no power at high speed	<input type="checkbox"/> spark plug loose (tighten it).
	<input type="checkbox"/> spark plug dirty, broken, or gap maladjusted (remedy it).
	<input type="checkbox"/> spark plug incorrect (replace it).
	<input type="checkbox"/> knocking (fuel poor quality or incorrect, → use high-octane gasoline).
	<input type="checkbox"/> brake dragging.
	<input type="checkbox"/> clutch slipping.
	<input type="checkbox"/> engine overheating.
	<input type="checkbox"/> engine oil level too high.
	<input type="checkbox"/> engine oil viscosity too high.
<input type="checkbox"/> other:	

## 3-30 FUEL SYSTEM (DFI)

### DFI System Troubleshooting Guide

#### NOTE

- This is not an exhaustive list, giving every possible cause for each problem listed. It is meant simply as a rough guide to assist the troubleshooting for some of the more common difficulties.
- The ECU may be involved in the DFI electrical and ignition system troubles. If these parts and circuits are checked out good, be sure to check the ECU for ground and power supply. If the ground and power supply are checked good, replace the ECU.

#### Engine Doesn't Start, Starting Difficulty

Symptoms or possible Causes	Actions
<b>Starter motor not rotating:</b>	
Ignition and engine stop switches not ON	Turn both switches ON.
Starter lockout switch or neutral switch trouble	Inspect (see chapter 16)
Starter motor trouble	Inspect (see chapter 16).
Battery voltage low	Inspect and charge (see chapter 16).
Starter relays not contacting or operating	Inspect the starter relay (see chapter 16).
Starter button not contacting	Inspect and replace (see chapter 16).
Starter system wiring open or shorted	Inspect the wiring (see chapter 16).
Ignition switch trouble	Inspect and replace (see chapter 16).
Engine stop switch trouble	Inspect and repair or replace (see chapter 16).
Main 30 A or ignition fuse blown	Inspect and replace (see chapter 16).
<b>Starter motor rotating but engine doesn't turn over:</b>	
Starter clutch trouble	Inspect (see chapter 16).
Starter idle gear trouble	Inspect (see chapter 16).
<b>Engine won't turn over:</b>	
Valve seizure	Inspect and replace (see chapter 5).
Cylinder, piston seizure	Inspect and replace (see chapter 5).
Camshaft seizure	Inspect and replace (see chapter 5).
Connecting rod small end seizure	Inspect and replace (see chapter 9).
Connecting rod big end seizure	Inspect and replace (see chapter 9).
Crankshaft seizure	Inspect and replace (see chapter 9).
Transmission gear or bearing seizure	Inspect and replace (see chapter 9).
Balancer bearing seizure	Inspect and replace (see chapter 9).
<b>No fuel flow:</b>	
No or little fuel in tank	Supply fuel (see Owner's Manual).
Fuel pump not rotating	Inspect (see chapter 3).
Fuel injector trouble	Inspect and replace (see chapter 3).
Fuel tank air vent obstructed	Inspect and repair (see chapter 3).
Fuel filter or pump screen clogged	Inspect and replace fuel pump (see chapter 3).
Fuel pressure regulator clogged	Inspect and replace fuel pump (see chapter 3).
Fuel line clogged	Inspect and repair (see chapter 3).
<b>Engine flooded:</b>	
Spark plug dirty, broken or gap maladjusted	Replace (see chapter 2).
Starting technique faulty	When flooded, don't crank engine with throttle fully opened.
<b>No spark or spark weak:</b>	
Ignition and engine stop switches not ON	Turn both switches ON .

**DFI System Troubleshooting Guide**

<b>Symptoms or possible Causes</b>	<b>Actions</b>
Clutch lever not pulled in and gear not in neutral whether sidestand up or not	Pull the lever in and shift the gear in neutral.
Though clutch lever pulled in, sidestand up and gear not in neutral	Side stand down and clutch lever pulled in whether gear in neutral or not
Vehicle-down Sensor coming off	Reinstall (see chapter 3).
Vehicle-down Sensor trouble	Inspect (see chapter 3) .
ECU ground or power supply trouble	Inspect (see chapter 3) .
Battery voltage low	Inspect and charge (see chapter 16).
Spark plug dirty, broken or gap maladjusted	Replace (see chapter 2).
Spark plug cap trouble	Inspect stick coil (see chapter 16).
Spark plug cap shorted or not in good contact	Reinstall or inspect stick coil (see chapter 16).
Spark plug incorrect	Replace it with the correct plug (see chapter 16).
IC igniter in ECU trouble	Inspect (see chapter 16).
Neutral, starter lockout or side stand switch trouble	Inspect each switch (see chapter 16).
Crankshaft sensor trouble	Inspect (see chapter 16).
Stick coil trouble	Inspect (see chapter 16).
Ignition switch shorted	Inspect and replace (see chapter 16).
Engine stop switch shorted	Inspect and repair or replace (see chapter 2) .
Starter system wiring shorted or open	Inspect and repair or replace (see chapter 16).
Main 30 A or ignition fuse blown	Inspect and replace (see chapter 16).
<b>Fuel/air mixture incorrect:</b>	
Air cleaner clogged, poorly sealed or missing	Clean or reinstall (see chapter 3).
Leak from oil filler cap, crankcase breather hose or air cleaner drain hose	Inspect and repair or replace (see chapter 3).
Water or foreign matter in fuel	Change fuel. Inspect and clean fuel system (see chapter 3).
Fuel pressure regulator trouble	Inspect fuel pressure and replace fuel pump (see chapter 3).
Main throttle sensor trouble	Inspect (see chapter 3).
Fuel pressure may be low	Inspect (see chapter 3).
Fuel pump trouble	Inspect (see chapter 3).
Fuel injector trouble	Inspect (see chapter 3).
Inlet air pressure sensor trouble	Inspect (see chapter 3).
Atmospheric pressure sensor trouble	Inspect (see chapter 3).
Inlet air temperature sensor trouble	Inspect (see chapter 3).
Water temperature sensor trouble	Inspect (see chapter 3).
Crankshaft sensor trouble	Inspect (see chapter 3).
<b>Compression low:</b>	
Spark plug loose	Reinstall (see chapter 16).
Cylinder head not sufficiently tightened down	Tighten (see chapter 5).
Cylinder, piston worn	Inspect and replace (see chapter 5).
Piston ring bad (worn, weak, broken or sticking)	Inspect and replace (see chapter 5).
Piston ring/groove clearance excessive	Inspect and replace (see chapter 5).
Cylinder head gasket damaged	Replace (see chapter 5).

## 3-32 FUEL SYSTEM (DFI)

### DFI System Troubleshooting Guide

Symptoms or possible Causes	Actions
Cylinder head warped	Inspect and replace (see chapter 5).
No valve clearance	Adjust (see chapter 2).
Valve guide worn	Inspect and replace (see chapter 5).
Valve spring broken or weak	Inspect and replace (see chapter 5).
Valve not seating properly (valve bent, worn or carbon accumulating on seating surface)	Inspect and repair or replace (see chapter 5).

### Poor Running at Low Speed

Symptoms or Possible Causes	Actions
<b>Spark weak:</b>	
Battery voltage low	Inspect and charge (see chapter 16).
Spark plug dirty, broken or gap maladjusted	Replace (see chapter 2).
Spark plug cap trouble	Inspect the stick coil (see chapter 16).
Spark plug cap shorted or not in good contact	Reinstall or inspect stick coil (see chapter 16).
Spark plug incorrect	Replace it with the correct plug (see chapter 16).
IC igniter in ECU trouble	Inspect (see chapter 16).
Crankshaft sensor trouble	Inspect (see chapter 16).
Stick coil trouble	Inspect (see chapter 16).
<b>Fuel/air mixture incorrect:</b>	
Little fuel in tank	Supply fuel (see Owner's Manual).
Air cleaner clogged, poorly sealed, or missing	Clean element or inspect sealing (see chapter 2, 3).
Air cleaner duct loose	Reinstall (see chapter 3).
Air cleaner O-ring damaged	Replace (see chapter 3).
Fuel tank air vent obstructed	Inspect and repair (see chapter 3).
Throttle body assy loose	Reinstall (see chapter 3).
Throttle body assy O-ring damage	Replace (see chapter 3).
Fuel filter or pump screen clogged	Inspect and replace fuel pump (see chapter 3).
Fuel pressure regulator clogged	Inspect fuel pressure and replace fuel pump (see chapter 3).
Fuel line clogged	Inspect and repair (see chapter 3).
Inlet air pressure sensor trouble	Inspect (see chapter 3).
Inlet air temperature sensor trouble	Inspect (see chapter 3).
Thermostat trouble	Inspect and replace (see chapter 4).
<b>Unstable (rough) idling:</b>	
Fuel injector trouble	Inspect (see chapter 3).
Main throttle sensor trouble	Inspect (see chapter 3).
Crankshaft sensor trouble	Inspect (see chapter 3).
Throttle valves not synchronizing	Inspect (see chapter 2).
Inlet air temperature sensor trouble	Inspect (see chapter 3).
Water temperature sensor trouble	Inspect (see chapter 3).
Atmospheric pressure sensor trouble	Inspect (see chapter 3).
Fuel pressure too low or too high	Inspect (see chapter 3).
Battery voltage low	Inspect and charge (see chapter 16).

**DFI System Troubleshooting Guide**

Symptoms or Possible Causes	Actions
<b>Incorrect idle speed:</b>	
Water temperature sensor trouble	Inspect (see chapter 3).
Main throttle sensor trouble	Inspect (see chapter 3).
<b>Engine stalls easily:</b>	
Fuel pump trouble	Inspect (see chapter 3).
Fuel injector trouble	Inspect (see chapter 3).
Main throttle sensor trouble	Inspect (see chapter 3).
Camshaft position sensor trouble	Inspect (see chapter 3).
Fuel pressure too low or too high	Inspect (see chapter 3).
Inlet air pressure sensor trouble	Inspect (see chapter 3).
Water temperature sensor trouble	Inspect (see chapter 3).
Inlet air temperature sensor trouble	Inspect (see chapter 3).
Fuel line clogged	Inspect and repair (see chapter 3).
Fuel pressure too low or too high	Inspect (see chapter 3).
Fuel pressure regulator trouble	Inspect fuel pressure and replace fuel pump (see chapter 3).
Crankshaft sensor trouble	Inspect (see chapter 16).
Stick coil trouble	Inspect (see chapter 16).
<b>Compression Low:</b>	
Spark plug loose	Reinstall (see chapter 16).
Cylinder head not sufficiently tightened down	Tighten (see chapter 5).
No valve clearance	Adjust (see chapter 2).
Cylinder, piston worn	Inspect and replace (see chapter 5).
Piston ring bad (worn, weak, broken or sticking )	Inspect and replace (see chapter 5).
Piston ring/groove clearance excessive	Inspect and replace (see chapter 5).
Cylinder head gasket damaged	Replace (see chapter 5).
Cylinder head warped	Inspect and replace (see chapter 5).
Valve guide worn or stem seal damaged	Inspect and replace (see chapter 5).
Valve spring broken or weak	Inspect and replace (see chapter 5).
Valve not seating properly (valve bent, worn or carbon accumulating on seating surface)	Inspect and repair or replace (see chapter 5).
Camshaft cam worn	Inspect and replace (see chapter 5).
<b>Hesitation:</b>	
Too low fuel pressure	Inspect (see chapter 3).
Clogged fuel line	Inspect and repair (see chapter 3).
Cracked or obstructed inlet air pressure sensor hose	Inspect and repair or replace (see chapter 3).
Fuel pump trouble	Inspect (see chapter 3).
Fuel injector trouble	Inspect (see chapter 3).
Inlet air temperature sensor trouble	Inspect (see chapter 3).
Main throttle sensor trouble	Inspect (see chapter 3).
Subthrottle sensor trouble	Inspect (see chapter 3).
Subthrottle valve actuator trouble	Inspect (see chapter 3).
Water temperature sensor trouble	Inspect (see chapter 3).
Atmospheric pressure sensor trouble	Inspect (see chapter 3).

### 3-34 FUEL SYSTEM (DFI)

#### DFI System Troubleshooting Guide

Symptoms or Possible Causes	Actions
Inlet air pressure sensor trouble	Inspect (see chapter 3).
Loose injector connectors	Remedy (see chapter 3).
Crankshaft sensor trouble	Inspect and repair or replace (see chapter 16).
Stick coil trouble	Inspect and repair or replace (see chapter 16).
Loose terminal of battery (–) cable or engine ground lead	Inspect and repair (see chapter 16).
Delay of ignition timing	Inspect crankshaft sensor and IC igniter in ECU (see chapter 16).
<b>Poor acceleration:</b>	
Too low fuel pressure	Inspect (see chapter 3).
Water or foreign matter in fuel	Change fuel. Inspect and clean fuel system (see chapter 3).
Clogged fuel filter or pump screen	Inspect and replace fuel pump (see chapter 3).
Fuel pump trouble	Inspect (see chapter 3).
Fuel injector trouble	Inspect (see chapter 3).
Inlet air temperature sensor trouble	Inspect (see chapter 3).
Water temperature sensor trouble	Inspect (see chapter 3).
Atmospheric pressure sensor trouble	Inspect (see chapter 3).
Subthrottle sensor trouble	Inspect (see chapter 3).
Subthrottle valve actuator trouble	Inspect (see chapter 3).
Stick coil trouble	Inspect and replace (see chapter 16).
Engine oil level too high	Repair (see chapter 7).
Spark plug dirty, broken or gap maladjusted	Replace (see chapter 2).
<b>Stumble:</b>	
Too low fuel pressure	Inspect (see chapter 3).
Fuel injector trouble	Inspect (see chapter 3).
Main throttle sensor malfunction	Inspect (see chapter 3).
Subthrottle sensor trouble	Inspect (see chapter 3).
Subthrottle valve actuator trouble	Inspect (see chapter 3).
Water temperature sensor trouble	Inspect (see chapter 3).
Inlet air pressure sensor trouble	Inspect (see chapter 3).
<b>Surge:</b>	
Unstable fuel pressure	Fuel pressure regulator trouble (Inspect and replace fuel pump) or kinked fuel line (Inspect and repair fuel line) (see chapter 3).
Fuel injector trouble	Inspect (see chapter 3).
Water temperature sensor trouble	Inspect (see chapter 3).
<b>Backfiring when deceleration:</b>	
Spark plug dirty, broken or gap maladjusted	Replace (see chapter 2).
Too low fuel pressure	Inspect (see chapter 3).
Fuel pump trouble	Inspect (see chapter 3).
Main throttle sensor trouble	Inspect (see chapter 3).
Inlet air temperature sensor trouble	Inspect (see chapter 3).
Water temperature sensor trouble	Inspect (see chapter 3).
Atmospheric pressure sensor trouble	Inspect (see chapter 3).

**DFI System Troubleshooting Guide**

Symptoms or Possible Causes	Actions
Inlet air pressure sensor trouble	Inspect (see chapter 3).
Vacuum switch valve broken	Inspect and replace (see chapter 5).
Air suction valve trouble	Inspect and replace (see chapter 5).
<b>After fire:</b>	
Crankshaft sensor trouble	Inspect (see chapter 16).
Spark plug burned or gap maladjusted	Replace (see chapter 2).
Inlet air temperature sensor trouble	Inspect (see chapter 3).
Water temperature sensor trouble	Inspect (see chapter 3).
Atmospheric pressure sensor trouble	Inspect (see chapter 3).
Inlet air pressure sensor trouble	Inspect (see chapter 3).
Fuel injector trouble	Inspect (see chapter 3).
<b>Run-on (dieseling):</b>	
Ignition switch trouble	Inspect and replace (see chapter 16).
Engine stop switch trouble	Inspect and repair or replace (see chapter 2).
Fuel injector trouble	Inspect (see chapter 3).
Loose terminal of battery (-) cable or ECU ground lead	Inspect and repair (see chapter 16).
Carbon accumulating on valve seating surface	Repair (see chapter 5).
Engine overheating	(see Overheating of Troubleshooting Guide, see chapter 17)
<b>Other:</b>	
Engine oil viscosity too high	Change (see chapter 2).
Drive train trouble	Inspect drive chain (see chapter 2) and sprocket (see chapter 11).
Brake dragging	Inspect caliper fluid seal damage or clogging of master cylinder relief and supply ports (see chapter 12).
Clutch slipping	Inspect friction plates for wear (see chapter 6).
Engine overheating	(see Overheating of Troubleshooting Guide, see chapter 17)
Vacuum switch valve trouble	Inspect and replace (see chapter 5).
Air suction valve trouble	Inspect and replace (see chapter 5).
Intermittent any DFI fault and its recovery	Check that DFI connectors are clean and tight, and examine wires for signs of burning or fraying (see chapter 3).

**Poor Running or No Power at High Speed:**

Symptoms or Possible Causes	Actions
<b>Firing incorrect:</b>	
Spark plug dirty, broken or maladjusted	Replace (see chapter 2).
Spark plug cap trouble	Inspect stick coil (see chapter 16).
Spark plug cap shorted or not in good contact	Reinstall or inspect stick coil (see chapter 16).
Spark plug incorrect	Replace it with the correct plug (see chapter 16).
IC igniter in ECU trouble	Inspect (see chapter 16).
Crankshaft sensor trouble	Inspect (see chapter 16).

### 3-36 FUEL SYSTEM (DFI)

#### DFI System Troubleshooting Guide

Symptoms or Possible Causes	Actions
Stick coil trouble	Inspect (see chapter 16).
<b>Fuel/air mixture incorrect:</b>	
Air cleaner clogged, poorly sealed, or missing	Clean element or inspect sealing (see chapter 3).
Air cleaner duct loose	Reinstall (see chapter 3).
Air cleaner O-ring damaged	Replace (see chapter 3).
Water or foreign matter in fuel	Change fuel. Inspect and clean fuel system (see chapter 3).
Throttle body assy loose	Reinstall (see chapter 3).
Throttle body assy O-ring damaged	Replace (see chapter 3).
Fuel tank air vent obstructed	Inspect and repair (see chapter 3).
Fuel line clogged	Inspect and repair (see chapter 3).
Fuel pump operates intermittently and often DFI fuse blows.	Pump bearings may wear. Replace the pump (see chapter 3).
Fuel pump trouble	Inspect (see chapter 3).
Inlet air temperature sensor trouble	Inspect (see chapter 3).
Main throttle sensor trouble	Inspect (see chapter 3).
Atmospheric pressure sensor trouble	Inspect (see chapter 3).
Inlet air pressure sensor trouble	Inspect (see chapter 3).
Cracked or obstructed inlet air pressure sensor hose	Inspect and repair or replace (see chapter 3).
Injector clogged	Visually inspect and replace (see chapter 3).
<b>Compression low:</b>	
Spark plug loose	Reinstall (see chapter 16).
Cylinder head not sufficiently tightened down	Tighten (see chapter 5).
No valve clearance	Adjust (see chapter 2).
Cylinder, piston worn	Inspect and replace (see chapter 5).
Piston ring bad (worn, weak, broken or sticking)	Inspect and replace (see chapter 5).
Piston ring/groove clearance excessive	Inspect and replace (see chapter 5).
Cylinder head gasket damaged	Replace (see chapter 5).
Cylinder head warped	Inspect and replace (see chapter 5).
Valve spring broken or weak	Inspect and replace (see chapter 5).
Valve not seating properly (valve bent, worn or carbon accumulating on the seating surface)	Inspect and repair or replace (see chapter 5).
<b>Knocking:</b>	
Carbon built up in combustion chamber	Repair (see chapter 5).
Fuel poor quality or incorrect (Use the gasoline recommended in the Owner's Manual)	Change fuel (see chapter 3).
Spark plug incorrect	Replace it with the correct plug (see chapter 16).
Stick coil trouble	Inspect (see chapter 16).
IC igniter in ECU trouble	Inspect (see chapter 16).
Inlet air temperature sensor trouble	Inspect (see chapter 3).
Atmospheric pressure sensor trouble	Inspect (see chapter 3).
<b>Miscellaneous:</b>	
Subthrottle sensor trouble	Inspect (see chapter 3).
Subthrottle valve actuator trouble	Inspect (see chapter 3).

**DFI System Troubleshooting Guide**

<b>Symptoms or Possible Causes</b>	<b>Actions</b>
Speed sensor trouble	Inspect (see chapter 3).
Throttle valves won't fully open	Inspect throttle cable and lever linkage (see chapter 3).
Brake dragging	Inspect caliper fluid seal damage or clogging of master cylinder relief and supply ports (see chapter 12).
Clutch slipping	Inspect friction plates for wear (see chapter 6).
Engine overheating-Water temperature sensor, crankshaft sensor or speed sensor trouble	(see Overheating of Troubleshooting Guide in chapter 17).
Engine oil level too high	Repair (see chapter 7).
Engine oil viscosity too high	Change (see chapter 2).
Drive train trouble	Inspect drive chain (see chapter 2) and sprockets (see chapter 11).
Camshaft cam worn	Inspect and replace (see chapter 5).
Vacuum switch valve trouble	Inspect and replace (see chapter 5).
Air suction valve trouble	Inspect and replace (see chapter 5).
Catalytic converters melt down due to muffler overheating (KLEEN)	Replace muffler (see chapter 5).
<b>Exhaust Smokes Excessively:</b>	
<b>(White smokes)</b>	
Piston oil ring worn	Inspect and replace (see chapter 5).
Cylinder worn	Inspect and replace (see chapter 5).
Valve oil seal damaged	Replace (see chapter 5).
Valve guide worn	Replace the guide (see chapter 5).
Engine oil level too high	Repair (see chapter 7).
<b>(Black smoke)</b>	
Air cleaner clogged	Clean (see chapter 3).
Too high fuel pressure	Inspect (see chapter 3) .
Injector stuck open	Inspect (see chapter 3).
Water temperature sensor trouble	Inspect and replace (see chapter 3).
Inlet air temperature sensor trouble	Inspect and replace (see chapter 3).
<b>(Brown smoke)</b>	
Air cleaner duct loose	Reinstall (see chapter 3).
Air cleaner O-ring damaged	Replace (see chapter 3).
Too low fuel pressure	Inspect fuel line and fuel pump (see chapter 3).
Water temperature sensor trouble	Inspect and replace (see chapter 3).
Inlet air temperature sensor trouble	Inspect and replace (see chapter 3).

# 3-38 FUEL SYSTEM (DFI)

## Self-Diagnosis

### Self-diagnosis Outline

The self-diagnosis system has three modes and can be switched to another mode by grounding the self-diagnosis terminal [A].

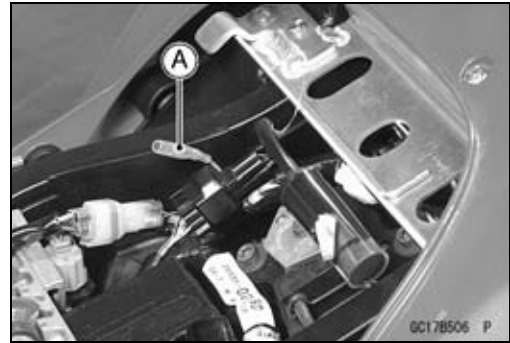

### User Mode

The ECU notifies the rider of troubles in DFI system and ignition system by lighting the FI indicator when DFI system and ignition system parts are faulty, and initiates fail-safe function. In case of serious troubles ECU stops the injection/ignition/starter motor operation.

### Dealer Mode 1

The FI indicator light (LED) emits service code(s) to show the problem(s) which the DFI system and ignition system has at the moment of diagnosis.

### Dealer Mode 2

The FI indicator light (LED) emits service code(s) to show the problem(s) which the DFI system and ignition system has at the moment of diagnosis.

### Self-diagnosis Procedures

○When a problem occurs with the DFI system and ignition system, the DFI indicator light (LED) [A] goes on.

#### NOTE

- Use a fully charged battery when conducting self-diagnosis. Otherwise, the light (LED) blinks very slowly or doesn't blink.
  - Keep the self-diagnosis terminal grounded during self-diagnosis, with a auxiliary lead.
- Remove the front seat (see Front Seat Removal in the Frame chapter) and pull the self-diagnosis terminal [G].
  - Turn the ignition switch ON.
  - Connect an auxiliary lead [E] for grounding to the self-diagnosis terminal.
  - To enter the self-diagnosis dealer mode 1, ground [A] the self-diagnosis terminal for more than 2 seconds [C], and then keep it grounded continuously [D].
- Count the blinks of the light (LED) to read the service code. Keep the auxiliary lead ground until you finish reading the service code.

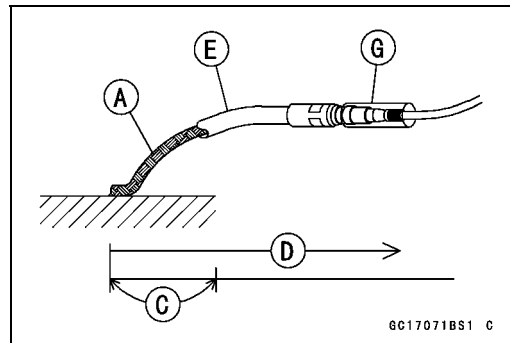

## Self-Diagnosis

- To enter the self-diagnosis dealer mode 2 repeat opening [B] and grounding [A] the lead more than five times [F] within 2 seconds [C] after the lead is first grounded, and then keep it grounded continuously [D] for more than 2 seconds.

Self-diagnosis Terminal [G]

- Count the blinks of the light (LED) to read the service code. Keep the auxiliary lead [E] ground until you finish reading the service code.

### NOTE

- If the self-diagnosis mode is in dealer mode 1 then you need to enter the dealer mode 2, turn off the ignition switch once.

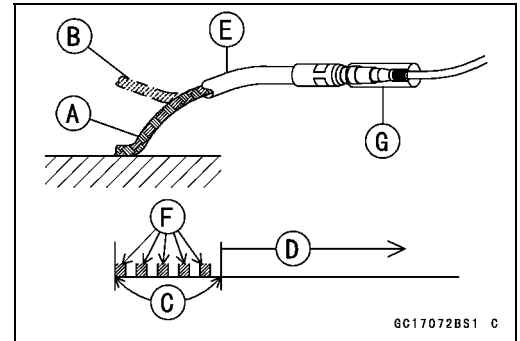

## Service Code Clearing Procedures

- Enter the self-diagnosis dealer mode 2 (see Self-diagnosis Procedures in this chapter).

### NOTE

- Make sure to keep the grounding until the following opening and grounding starts.

- Pull the clutch lever in more than 5 seconds, and then release it.
- Repeat opening [B] and grounding [A] the lead [E] (self-diagnosis terminal [G]) more than five times [F] within 2 seconds [C] after the lead is grounded, and then keep it grounded continuously [D] for more than 2 seconds.

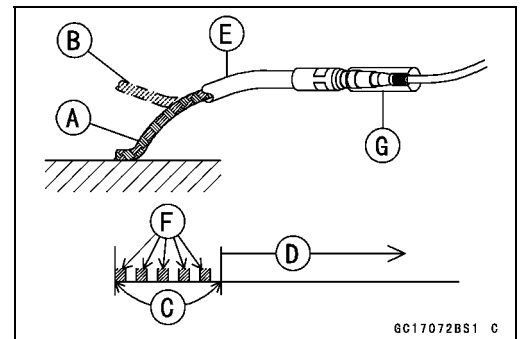

# 3-40 FUEL SYSTEM (DFI)

## Self-Diagnosis

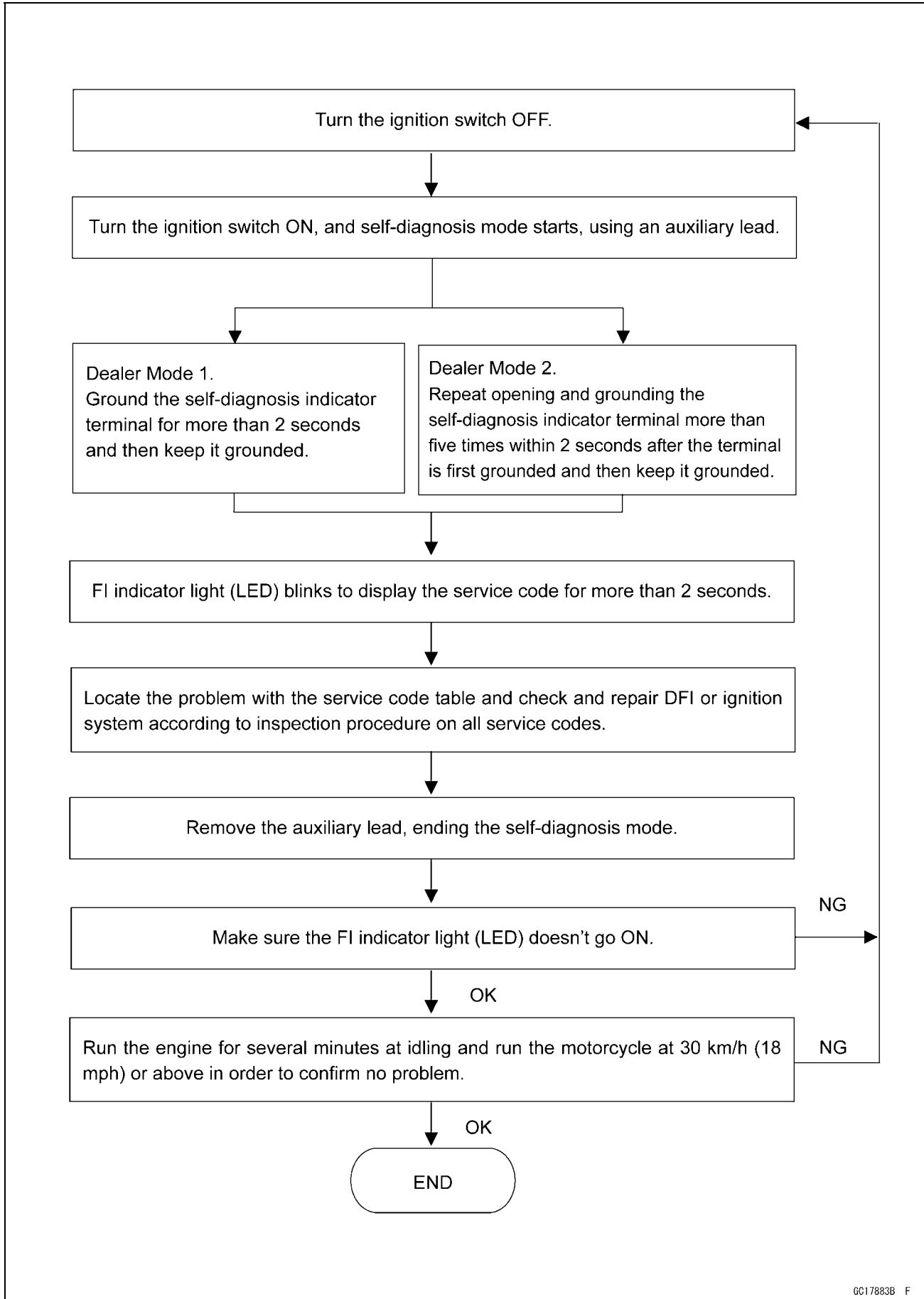

**Self-Diagnosis**

**Service Code Reading**

- Service codes are shown by a series of long and short blinks of the FI indicator light (LED) as shown below.
  - Read 10th digit and unit digit as the FI indicator light (LED) blinks.
  - When there are a number of problems, all the service codes can be stored and the display will begin starting from the lowest number service code in the numerical order. Then after completing all codes, the display is repeated until the self-diagnosis terminal is open.
  - If there is no problem, no code and unlight.
  - For example, if two problems occurred in the order of 21, 12, the service codes are displayed from the lowest number in the order listed.  
(12 → 21) → (12 → 21) → ··· (repeated)
- If the problem is with the following parts, the ECU cannot memorize these problems, the FI indicator light (LED) doesn't go on, and no service codes can be displayed.

- FI Indicator Light (LED)
- Fuel Pump
- Fuel Pump Relay
- ECU Main Relay
- ECU Power Source Wiring and Ground Wiring (see ECU Power Supply Inspection in this chapter)
- Fuel Injectors

- For example, if two problems of 12 and 21 occur, the service code 12 and 21 are shown as follows.

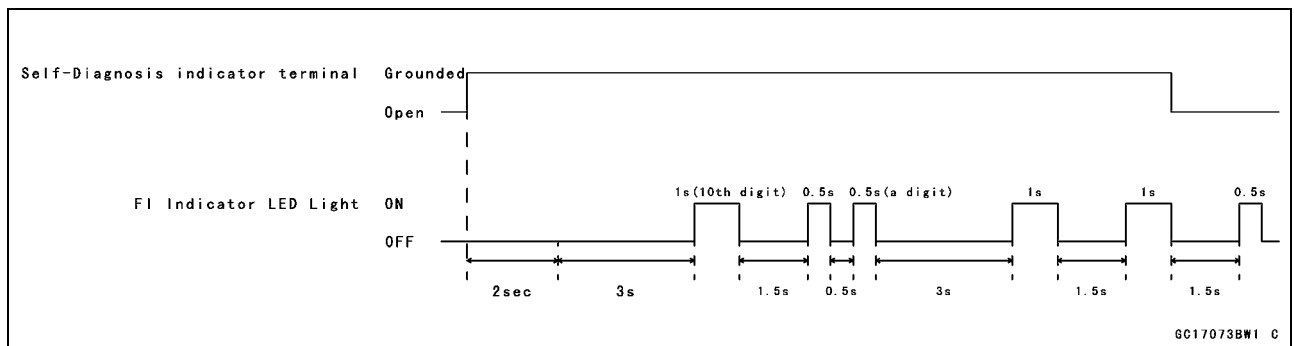

**Service Code Erasing**













- Even if the ignition switch is turned OFF the battery or the ECU are disconnected, or the problem is solved, all service codes remain in the ECU.
- Refer to the Service Code Clearing Procedure for the service code erasure.

**Service Code Table**

Service Codes	FI Indicator Light (LED)	Problems
11	ON OFF	Main throttle sensor malfunction, wiring open or short
12	ON OFF	Inlet air pressure sensor malfunction, wiring open or short
13	ON OFF	Inlet air temperature sensor malfunction, wiring open or short
14	ON OFF	Water temperature sensor malfunction, wiring open or short
15	ON OFF	Atmospheric pressure sensor malfunction, wiring open or short
21	ON OFF	Crankshaft sensor malfunction, wiring open or short

### 3-42 FUEL SYSTEM (DFI)

#### Self-Diagnosis

Service Codes	FI Indicator Light (LED)	Problems
23		Camshaft position sensor malfunction, wiring open or short
24		Speed sensor malfunction
31		Vehicle-down sensor malfunction, wiring open or short
32		Subthrottle sensor malfunction, wiring open or short
34		Exhaust butterfly valve sensor malfunction, wiring open or short
35		Immobilizer amplifier malfunction
36		Blank key detection
51		Stick (Ignition) coil #1 malfunction, wiring open or short
52		Stick (Ignition) coil #2 malfunction, wiring open or short
53		Stick (Ignition) coil #3 malfunction, wiring open or short
54		Stick (Ignition) coil #4 malfunction, wiring open or short
62		Subthrottle valve actuator malfunction, wiring open or short
63		Exhaust butterfly valve actuator malfunction, wiring open or short

**Notes:**

- The ECU may be involved in these problems. If all the parts and circuits checked out good, be sure to check the ECU for ground and power supply. If the ground and power supply are checked good, replace the ECU.
- When no service code is displayed, the electrical parts of the DFI system has no fault, and the mechanical parts of the DFI system and the engine are suspect.

**Self-Diagnosis**

**Backups**

○The ECU takes the following measures to prevent engine damage when the DFI or the ignition system parts have troubles.

Service Codes	Parts	Output Signal Usable Range or Criteria	Backups by ECU
11	Main Throttle Sensor	Main Throttle Sensor Output Voltage 1.02 ~ 4.62 V	If the main throttle sensor system fails (the signal is out of the usable range, wiring short or open), the ECU locks ignition timing into the ignition timing at closed throttle position and sets the DFI in the D-J method.
12	Inlet Air Pressure Sensor	Inlet Air Pressure (absolute) Pv = 100 mmHg ~ 900 mmHg	If the inlet air pressure sensor system fails (the signal Pv is out of the usable range, wiring short or open), the ECU sets the DFI in the α - N method (1).
13	Inlet Air Temperature Sensor	Inlet Air Temperature Ta = - 47°C ~ + 178°C	If the inlet air temperature sensor fails (the signal is out of the usable range, wiring short or open), the ECU sets Ta at 30°C.
14	Water Temperature Sensor	Water Temperature Tw = - 30C° ~ + 120°C	If the water temperature sensor system fails (the signal is out of the usable range, wiring short or open), the ECU sets Tw at 80°C.
15	Atmospheric Pressure Sensor	Absolute Atmospheric Pressure Pa = 100 mmHg ~ 900 mmHg	If the atmospheric pressure sensor system fails (the signal is out of the usable range, wiring short or open), the ECU sets Pa at 760 mmHg (the standard atmospheric pressure).
21	Crankshaft Sensor	Crankshaft sensor must send 23 signals (output signal) to the ECU at the one cranking.	If crankshaft sensor generates less than 23 or more signals, the engine stops by itself.
23	Camshaft Position Sensor	Camshaft position sensor must send one signals (output signal) to the ECU at the two crankings.	If the camshaft position sensor system fails (the signal is missing, wiring short or open), the ECU continues to ignite cylinders in the same sequence following the last good signal.
24	Speed Sensor	Speed Sensor must send 4 signals (output signal) to the ECU at the one rotation of the drive shaft	If the speed sensor system fails (no signal, wiring short or open), the speedometer shows 0.
31	Vehicle -down Sensor	Vehicle-down Sensor Output Voltage (signal) Vd = 0.2 ~ 4.8 V	If the vehicle-down sensor system has failures (the output voltage Vd is more than usable range, wiring open), the ECU shuts off the fuel pump, the fuel injectors and the ignition system.
32	Subthrottle Sensor	Subthrottle Sensor Output Voltage 0.2 ~ 4.8 V	If the subthrottle sensor system fails (the signal is out of the usable range, wiring short or open), the actuator locks subthrottle valve at full open position.
34	Exhaust Butterfly Valve Actuator Sensor	Exhaust Butterfly Valve Actuator Sensor Output Voltage 0.2 ~ 4.8 V	If the exhaust butterfly valve system fails (the signal is out of the usable range, wiring short or open), the actuator locks exhaust butterfly valve at full open position.
35	Immobilizer Amplifier	-	If the immobilizer system fails (no signal, wiring short or open), the vehicle is no start and run.

### 3-44 FUEL SYSTEM (DFI)

#### Self-Diagnosis

Service Codes	Parts	Output Signal Usable Range or Criteria	Backups by ECU
36	Master or User Key	The user or master key must use register key.	If the blank key or broken key is used, the vehicle is no start and run.
51	Stick Coil #1 (Ignition Coil)*	The ignition coil primary winding must send signals (output voltage) 32 or more times continuously to the ECU.	If the ignition primary winding #1 has failures (no signal, wiring short or open), the ECU shuts off the injector #1 to stop fuel to the cylinder #1, though the engine keeps running.
52	Stick Coil #2 (Ignition Coil)*	The ignition coil primary winding must send signals (output voltage) 32 or more times continuously to the ECU.	If the ignition primary winding #2 has failures (no signal, wiring short or open), the ECU shuts off the injector #2 to stop fuel to the cylinder #2, though the engine keeps running.
53	Stick Coil #3 (Ignition Coil)*	The ignition coil primary winding must send signals (output voltage) 32 or more times continuously to the ECU.	If the ignition primary winding #3 has failures (no signal, wiring short or open), the ECU shuts off the injector #3 to stop fuel to the cylinder #3, though the engine keeps running.
54	Stick Coil #4 (Ignition Coil) *	The ignition coil primary winding must send signals (output voltage) 32 or more times continuously to the ECU.	If the ignition primary winding #4 has failures (no signal, wiring short or open), the ECU shuts off the injector #4 to stop fuel to the cylinder #4, though the engine keeps running.
62	Subthrottle Valve Actuator	The actuator operates open and close of the subthrottle valve by the pulse signal from the ECU.	If the sub throttle actuator fails (the signal is out to the usable range, wiring short or open), the ECU stops the current to the actuator.
63	Exhaust Butterfly Valve Actuator	The actuator operates open and close of the exhaust butterfly valve by the pulse signal from the ECU.	If the exhaust butterfly valve actuator fails (the signal is out to the usable range, wiring short or open), the ECU stops the current to the actuator.

**Note:**

(1)  $\alpha$  - N Method: the DFI control method from medium to heavy engine load. When the engine load is light like at idling or low speed, the ECU determines the injection quantity by calculating from the throttle vacuum (vacuum sensor output voltage) and engine speed (crankshaft sensor output voltage). This method is called D-J method. As the engine speed increases, and the engine load turns middle to heavy, the ECU determines the injection quantity by calculating from the throttle opening (throttle sensor output voltage) and the engine speed. This method is called  $\alpha$  - N method.

\*: This depends on the number of stopped cylinders.

**Main Throttle Sensor (Service Code 11)**

The main throttle sensor is a rotating variable resistor that changes output voltage according to throttle operating. The ECU senses this voltage change and determines fuel injection quantity, and ignition timing according to engine rpm, and throttle opening.

- Input Terminal [A]
- Output Terminal [B]
- Ground Terminal [C]

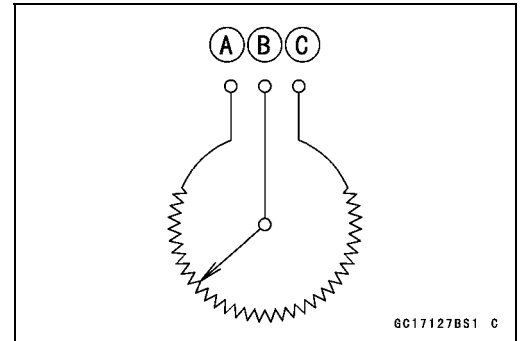

*Main Throttle Sensor Removal/Adjustment*

**CAUTION**

**Do not remove or adjust the main throttle sensor since it has been adjusted and set with precision at the factory.**

**Never drop the throttle body assy, especially on a hard surface. Such a shock to the sensor can damage it.**

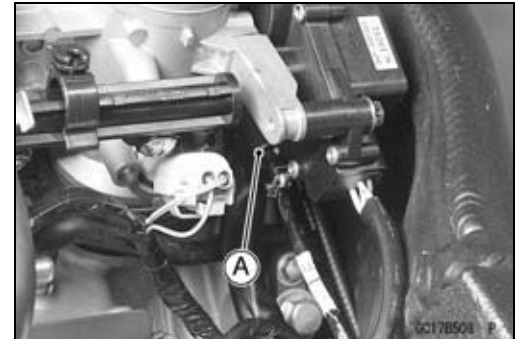

Main Throttle Sensor Connector [A]

*Input Voltage Inspection*

**NOTE**

○Be sure the battery is fully charged.

- Turn the ignition switch OFF.
- Remove the ECU (see ECU Removal in this chapter). Do not disconnect the ECU connectors.
- Connect a digital voltmeter [A] to the connectors [B], using the needle adapter set.

**Special Tool - Needle Adapter Set: 57001-1457**

**Main Throttle Sensor Input Voltage**

**Connections to ECU Connector**

- Meter (+) → BL lead (terminal 10)
- Meter (-) → BR/BK lead (terminal 28)

- Measure the input voltage with the engine stopped, and with the connectors joined.
- Turn the ignition switch ON.

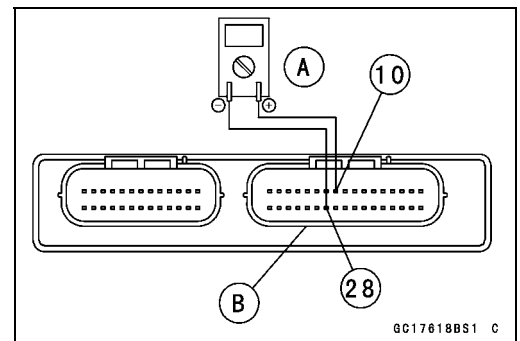

**Input Voltage at ECU Connector**

**Standard: DC 4.75 ~ 5.25 V**

- Turn the ignition switch OFF.
- ★ If the reading of input voltage is less than the standard, check the ECU for its ground, power supply and wiring shorted.
- ★ If the input voltage is within the standard range, check the input voltage at the main throttle sensor connector.
- Remove the throttle body assy temporarily (see Throttle Body Assy Removal in this chapter).

## 3-46 FUEL SYSTEM (DFI)

### Main Throttle Sensor (Service Code 11)

- Disconnect the main throttle sensor connector and connect the harness adapter [A] between the harness connector and main throttle sensor connector.

- Connect a digital meter to the harness adapter leads.

**Special Tool - Throttle Sensor Setting Adapter: 57001-1538**

#### Main Throttle Sensor Input Voltage

##### Connections to Sensor

**Meter (+)** → BL lead

**Meter (-)** → BR/BK lead

- Install the throttle body assy (see Throttle Body Assy Installation in this chapter).
- Measure the sensor input voltage with the engine stopped, and with the connector joined.
- Turn the ignition switch ON.

#### Input Voltage at Sensor

**Standard: DC 4.75 ~ 5.25 V**

- Turn the ignition switch OFF.
- ★ If the reading is out of the range, check the wiring (see wiring diagram in this section).
- ★ If the reading is good, check the output voltage of the sensor.

#### Output Voltage Inspection

- Measure the output voltage at the ECU in the same way as input voltage inspection.

Digital Voltmeter [A]

Connectors [B]

**Special Tool - Needle Adapter Set: 57001-1457**

#### Main Throttle Sensor Output Voltage

##### Connections to ECU

**Meter (+)** → Y/W lead (terminal 7)

**Meter (-)** → BR/BK lead (terminal 28)

- Start the engine and warm it up thoroughly.
- Check idle speed to ensure throttle opening is correct.

#### Idle Speed

**Standard: 1 300 r/min (rpm)**

- ★ If the idle speed is out of the specified range, adjust the idle speed (see Idle Speed Adjustment in the Periodic Maintenance chapter).
- Turn the ignition switch OFF.
- Measure the output voltage with the engine stopped, and with the connector joined.
- Turn the ignition switch ON.
- Measure the output voltage when the throttle is fully opened or completely closed.

#### Output Voltage at ECU

**Standard: DC 1.02 ~ 4.62 V (at idle throttle opening to full throttle opening)**

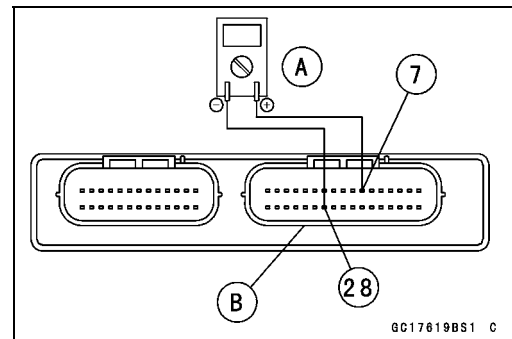
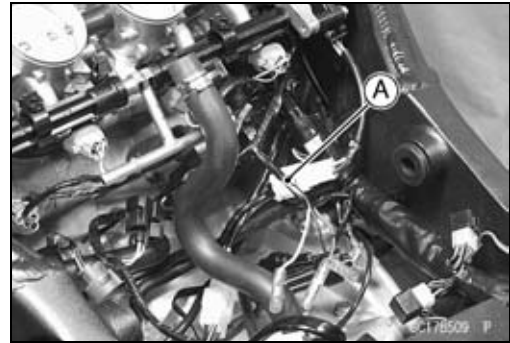

**Main Throttle Sensor (Service Code 11)**

**CAUTION**

**Do not remove or adjust the main throttle sensor. It has been adjusted and set with precision at the factory.**  
**Never drop the throttle body assy can especially on a hard surface. A shock to the sensor can damage it.**

- ★ If the output voltage is within the standard range, check the ECU for a good ground, and power supply (see ECU Power Supply Inspection in this chapter). If the ground and power supply are good, replace the ECU.
- ★ If the output voltage is far out of the standard range (e.g. when the wiring is open, the reading is 0 V), check the output voltage again at the sensor connector.
- Disconnect the main throttle sensor connector and connect the harness adapter [A] between the harness connector and main throttle sensor connector.
- Connect a digital meter to the harness adapter leads.

**Special Tool - Throttle Sensor Setting Adapter: 57001-1538**

**Throttle Sensor Output Voltage**

**Connections to Sensor**

**Meter (+) → Y/W lead**

**Meter (-) → BR/BK lead**

- Measure the sensor output voltage with the engine stopped, and with the connector joined.
- Turn the ignition switch ON.
- Measure the output voltage when the throttle is fully opened or completely closed.

**Output Voltage at Sensor**

**Standard: DC 1.02 ~ 4.62 V (at idle throttle opening to full throttle opening)**

**CAUTION**

**Do not remove or adjust the main throttle sensor. It has been adjusted and set with precision at the factory.**  
**Never drop the throttle body assy, especially on a hard surface. A shock to the sensor can damage it.**

- After throttle sensor voltage inspection, remove the harness adapter.
- ★ If the reading is out of the standard range, inspect the throttle sensor resistance.
- ★ If the output voltage is normal, check the wiring for continuity (see next diagram).

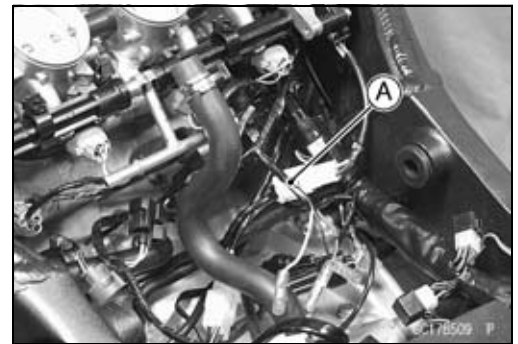

# 3-48 FUEL SYSTEM (DFI)

## Main Throttle Sensor (Service Code 11)

### Resistance Inspection

- Turn the ignition switch OFF.
- Disconnect the main throttle sensor connector.
- Connect a digital meter [A] to the main throttle sensor connector [B].
- Measure the main throttle sensor resistance.

### Main Throttle Sensor Resistance

Connections: BL lead [C] ↔ BR/BK lead [D]

Standard: 4 ~ 6 kΩ

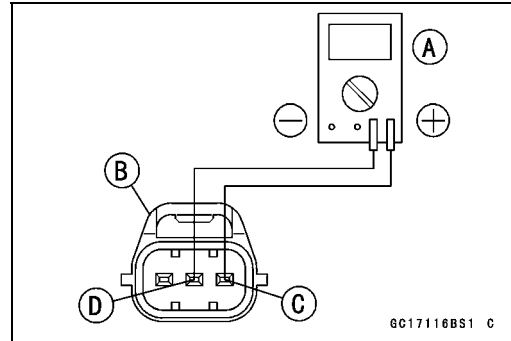

- ★ If the reading is out of the range, replace the throttle body assy (see Throttle Body Assy Removal/Installation in this chapter).
- ★ If the reading is within the range, but the problem still exists, replace the ECU (see ECU Removal/Installation in this chapter).

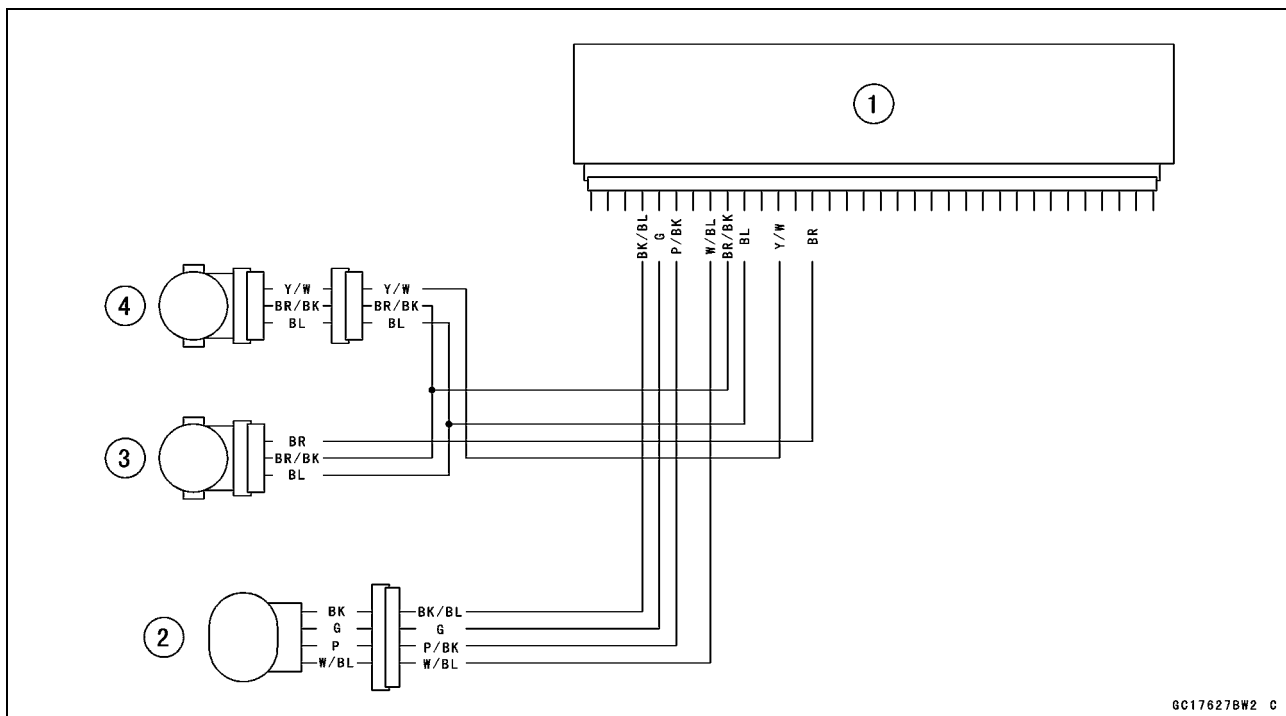

1. ECU
2. Subthrottle Valve Actuator
3. Subthrottle Sensor
4. Main Throttle Sensor

**Inlet Air Pressure Sensor (Service Code 12)**

**CAUTION**

**Never drop the sensor, especially on a hard surface. Such a shock to the part can damage it.**

*Removal*

- Turn the ignition switch OFF.
- Remove:
  - Air Cleaner Housing (see Air Cleaner Housing Removal in this chapter)
  - Inlet Air Pressure Sensor Connector [A]
  - Inlet Air Pressure Sensor [B]
  - Vacuum Hose [C]

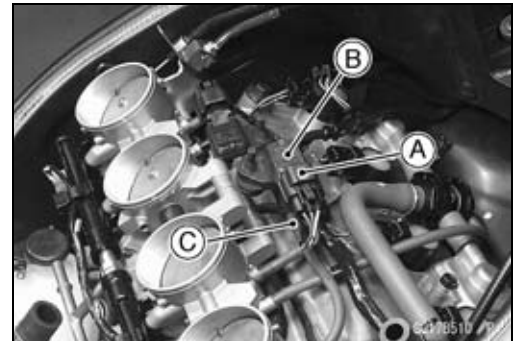

*Installation*

**NOTE**

○The inlet air pressure sensor is the same part as the atmospheric sensor except that the sensor has a vacuum hose and different wiring.

- Install:
  - Vacuum Hose
- Put the inlet air pressure sensor in the stay plate [A] of throttle body assy.

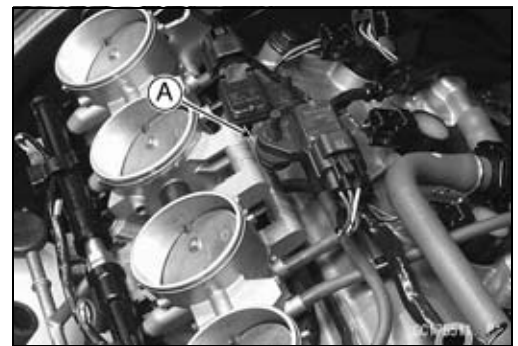

*Input Voltage Inspection*

**NOTE**

○Be sure the battery is fully charged.  
 ○The inspection is the same as "Input Voltage Inspection" of the throttle sensor and the atmospheric pressure sensor.

- Turn the ignition switch OFF.
- Remove the ECU (see ECU Removal in this chapter). Do not disconnect the ECU connectors.
- Connect a digital voltmeter [A] to the connector [B], with the needle adapter set.

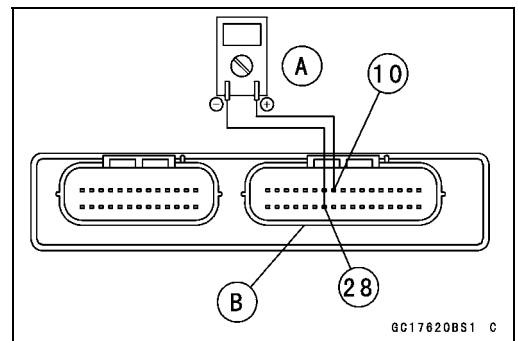

**Special Tool - Needle Adapter Set: 57001-1457**

**Inlet Air Pressure Sensor Input Voltage**

**Connections to ECU**

- Meter (+)** → BL lead (terminal 10)
- Meter (-)** → BR/BK lead (terminal 28)

- Measure the input voltage with the engine stopped, and with the connectors joined.
- Turn the ignition switch ON.

**Input Voltage at ECU**

**Standard: DC 4.75 ~ 5.25 V**

★If the reading is less than the standard range, check the ECU for its ground, and power supply (see ECU Power Supply Inspection in this chapter). If the ground and power supply are good, replace the ECU (see ECU Removal/Installation in this chapter).

## 3-50 FUEL SYSTEM (DFI)

### Inlet Air Pressure Sensor (Service Code 12)

- ★ If the reading is within the standard range, and check the input voltage again at the sensor connector.
- Remove the air cleaner housing (see Air Cleaner Housing Removal in this chapter).
- Disconnect the inlet air pressure sensor connector and connect the harness adapter [A] between the sub harness connector and inlet air pressure sensor connector.
- Connect a digital meter to the harness adapter leads. Inlet Air Pressure Sensor [B]

**Special Tool - Sensor Harness Adapter: 57001-1561**

#### Inlet Air Pressure Sensor Input Voltage

##### Connections to Sensor

Meter (+) → BL lead [C]

Meter (-) → BR/BK lead [D]

- Measure the input voltage with the engine stopped.
- Turn the ignition switch ON.

#### Input Voltage at Sensor Connector

**Standard: DC 4.75 ~ 5.25 V**

- ★ If the reading is out of the standard range, check the wiring (see wiring diagram in this section).
- ★ If the reading is good, the input voltage is normal. Check the output voltage.
- Turn the ignition switch OFF.

#### Output Voltage Inspection

- Measure the output voltage at the ECU in the same way as input voltage inspection.

#### Inlet Air Pressure Sensor Output Voltage

##### Connections to ECU

Meter (+) → Y/BL lead (terminal 8)

Meter (-) → BR/BK lead (terminal 28)

#### Output Voltage at ECU

**Usable Range: DC 3.80 ~ 4.20 V at the standard atmospheric pressure (101.32 kPa, 76 cmHg abs.)**

#### NOTE

- The output voltage changes according to the local atmospheric pressure.
  - The inlet air pressure sensor output voltage is based on a nearly perfect vacuum in the small chamber of the sensor. So, the sensor indicates absolute vacuum pressure.
- ★ If the output voltage is within the usable range, check the ECU for its ground, and power supply (see ECU Power Supply Inspection in this chapter). If the ground and power supply are good, replace the ECU (see ECU Removal/Installation in this chapter).

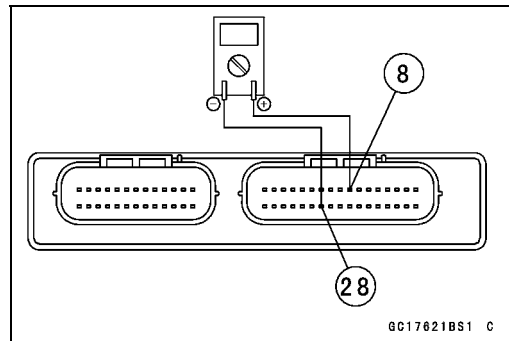
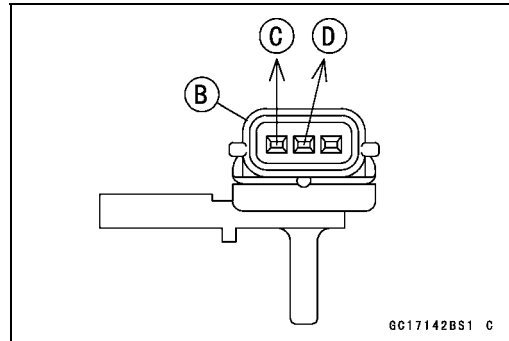
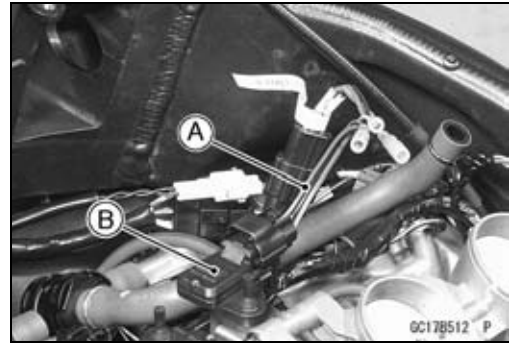

**Inlet Air Pressure Sensor (Service Code 12)**

★ If the output voltage is far out of the usable range, check the output voltage again at the sensor connector [A] (when the lead is open, the output voltage is about 1.8 V.).

- Connect a digital meter to the harness adapter leads. Inlet Air Pressure Sensor [B]

**Special Tool - Sensor Harness Adapter: 57001-1561**

**Inlet Air Pressure Sensor Output Voltage**

**Connections to Sensor**

Meter (+) → Y/BL lead [C]

Meter (-) → BR/BK lead [D]

**Output Voltage at Sensor Connector**

**Usable Range: DC 3.80 ~ 4.20 V at the standard atmospheric pressure (101.32 kPa or 76 cmHg abs.)**

★ If the output voltage is normal, check the wiring for continuity (see wiring diagram in this section).

★ If the output voltage is out of the usable range, replace the sensor.

- Turn the ignition switch OFF.
- Remove the sensor harness adapter.

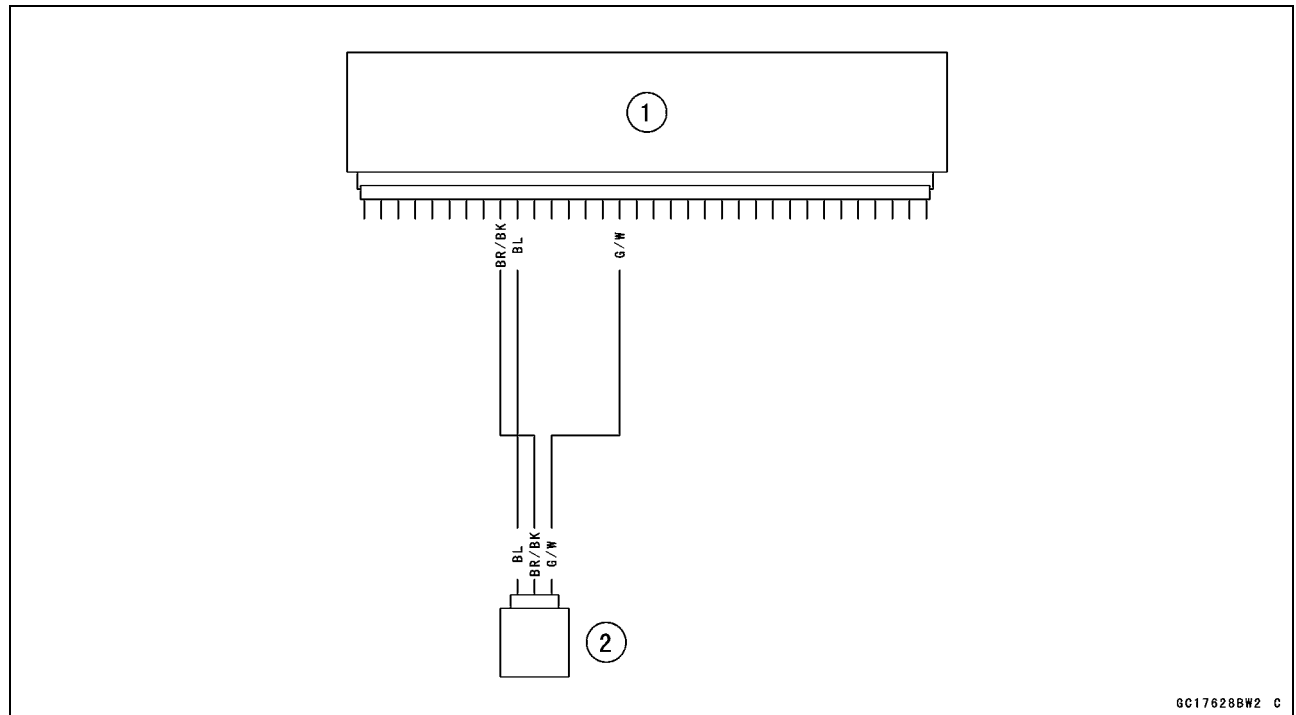
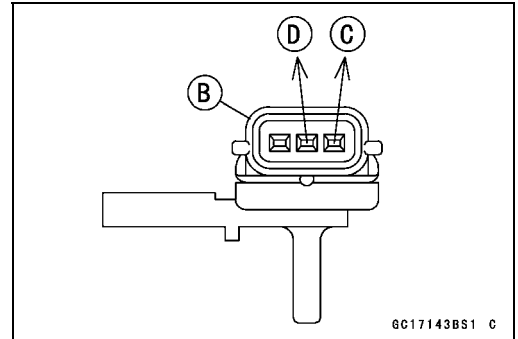
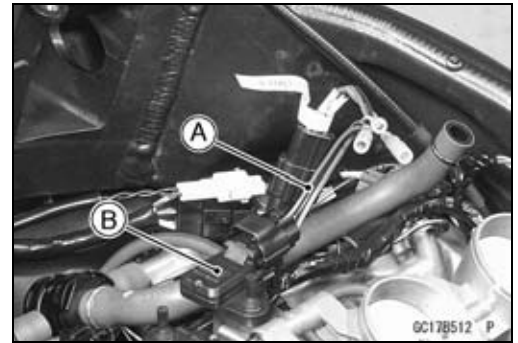

1. ECU
2. Inlet Air Pressure Sensor

★ If you need to check the inlet air pressure sensor for vacuum other than 76 cmHg (abs.), check the output voltage as follows:

## 3-52 FUEL SYSTEM (DFI)

### Inlet Air Pressure Sensor (Service Code 12)

- Remove the inlet air pressure sensor [A] and disconnect the vacuum hose from the sensor.
- Do not disconnect the sensor connector.
- Connect an auxiliary hose [B] to the inlet air pressure sensor.
- Temporarily install the inlet air pressure sensor.
- Connect a commercially available digital meter [C], vacuum gauge [D], and the fork oil level gauge [E] to the inlet air pressure sensor.

**Special Tools - Fork Oil Level Gauge: 57001-1290**  
**Sensor Harness Adapter: 57001-1561**

#### Inlet Air Pressure Sensor Output Voltage Connection to Sensor

**Meter (+) → Y/BL lead**

**Meter (-) → BR/BK lead**

- Turn the ignition switch ON.
- Measure the inlet air pressure sensor output voltage from various vacuum readings, while pulling the handle of the fork oil level gauge.
- Check the inlet air pressure sensor output voltage, using the following formula and chart.

Suppose:

Pg : Vacuum Pressure (gauge) of Throttle Assy

PI : Local Atmospheric Pressure (absolute) measured by a barometer

Pv : Vacuum Pressure (absolute) of Throttle Assy

Vv : Sensor Output Voltage (V)

then

$$Pv = PI - Pg$$

For example, suppose the following data is obtained:

Pg = 8 cmHg (vacuum gauge reading)

PI = 70 cmHg (barometer reading)

Vv = 3.2 V (digital volt meter reading)

then

$$Pv = 70 - 8 = 62 \text{ cmHg (abs.)}$$

Plot this Pv (62 cmHg) at a point [1] on the chart and draw a vertical line through the point. Then, you can get the usable range [2] of the sensor output voltage.

Usable range = 3.08 ~ 3.48 V

Plot Vv (3.2 V) on the vertical line. → Point [3].

**Results: In the chart, Vv is within the usable range and the sensor is normal.**

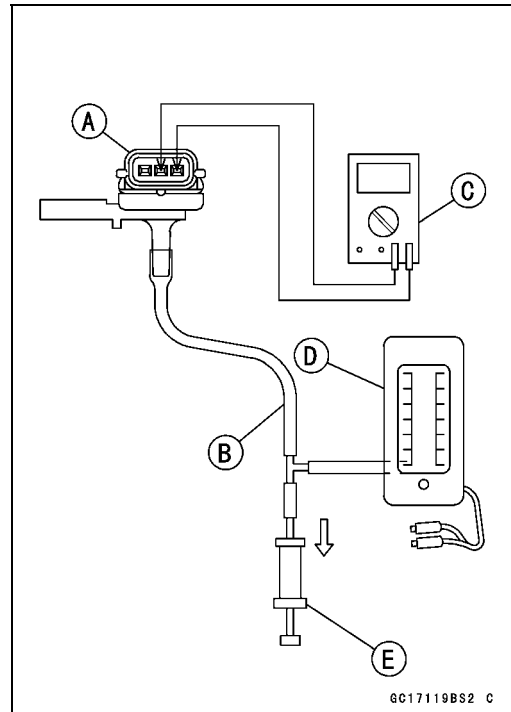

Inlet Air Pressure Sensor (Service Code 12)

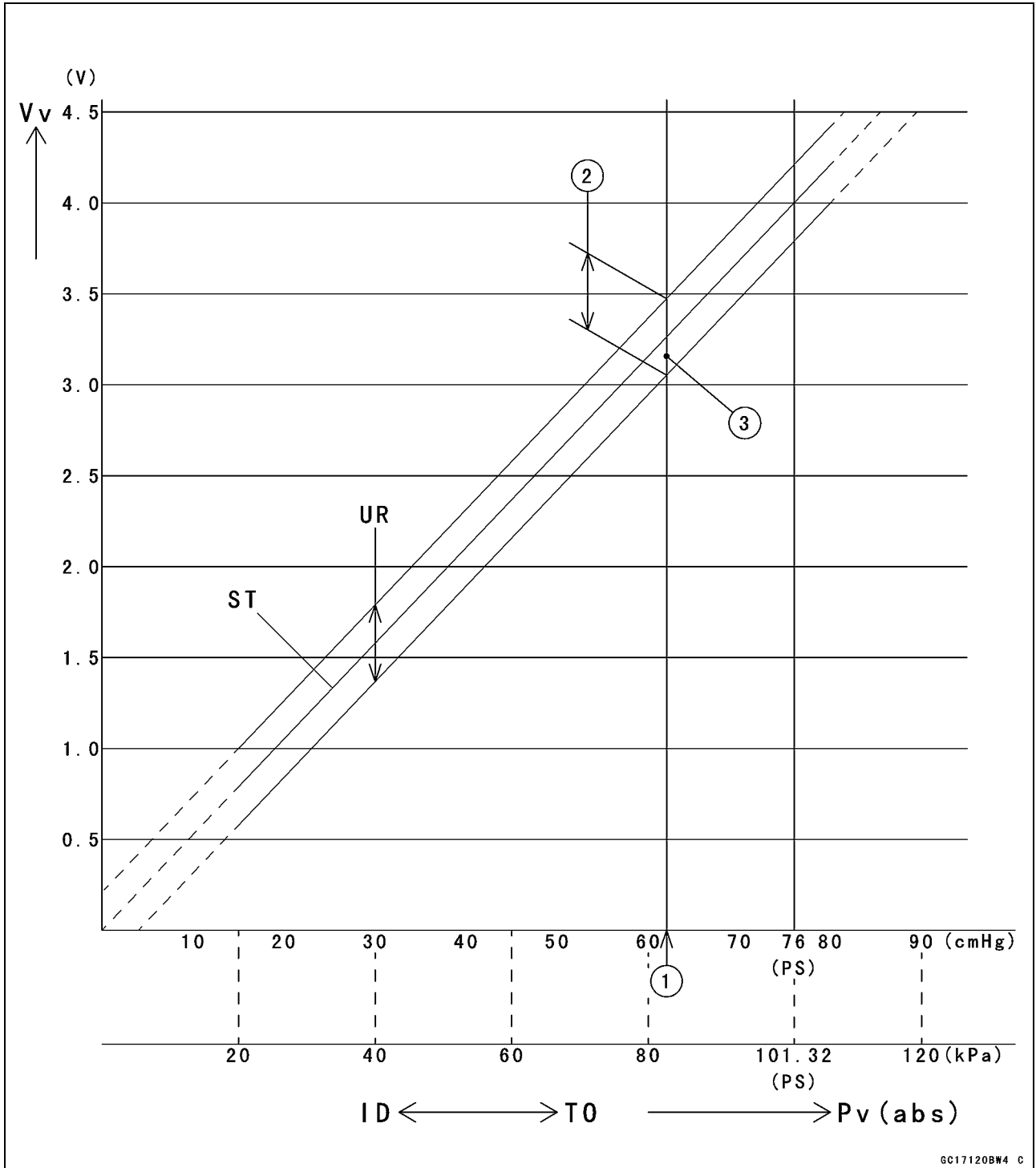

- ID: Idling
- Ps: Standard Atmospheric Pressure (Absolute)
- Pv: Throttle Vacuum Pressure (Absolute)
- ST: Standard of Sensor Output Voltage (V)
- TO: Throttle Full Open
- UR: Usable Range of Sensor Output Voltage (V)
- Vv: Inlet Air Pressure Sensor Output Voltage (V) (Digital Meter Reading)

## 3-54 FUEL SYSTEM (DFI)

### Inlet Air Temperature Sensor (Service Code 13)

#### Removal/Installation

#### CAUTION

**Never drop the sensor, especially on a hard surface. Such a shock to the sensor can damage it.**

- Remove the fuel tank (see Fuel Tank Removal in this chapter).
- Disconnect the connector [A] from the inlet air temperature sensor.
- Pull out the inlet air temperature sensor [B].
- Install the inlet air temperature sensor [A] in the grommet [B].

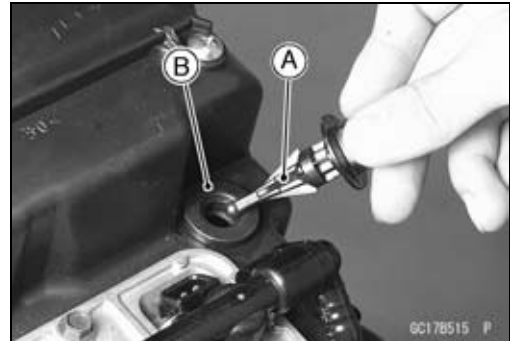
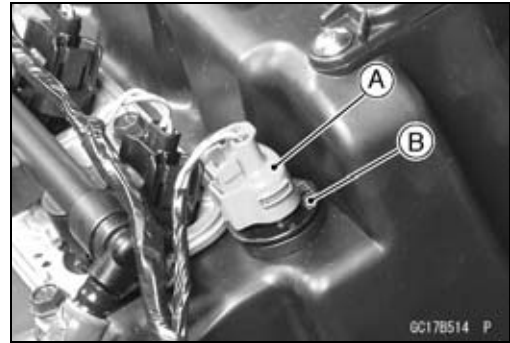

#### Output Voltage Inspection

#### NOTE

○Be sure the battery is fully charged.

- Remove the ECU (see ECU Removal in this chapter). Do not disconnect the ECU connectors.
- Connect a digital voltmeter [A] to the ECU connector, using needle adapter set [B].

**Special Tool - Needle Adapter Set: 57001-1457**

#### Inlet Air Temperature Sensor Output Voltage

##### Connections to ECU Connector

Meter (+) → P lead (terminal 26)

Meter (-) → BR/BK lead (terminal 28)

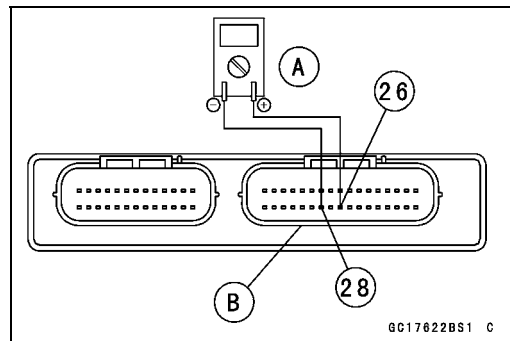

- Measure the sensor output voltage with the engine stopped and the connector joined.
- Turn the ignition switch ON.

#### Output Voltage at ECU

**Standard: About 2.25 ~ 2.50 V at inlet air temperature 20°C (68°F)**

#### NOTE

○The output voltage changes according to the inlet air temperature.

- Turn the ignition switch OFF.

## Inlet Air Temperature Sensor (Service Code 13)

- ★ If the output voltage is out of the specified, check the ECU for its ground, and power supply (see ECU Power Supply Inspection in this chapter). If the ground and power supply are good, replace the ECU (see ECU Removal/Installation in this chapter).
- ★ If the output voltage is far out of the specified (e.g. when the wiring is open, the voltage is about DC 5.0 V.), check the wiring (see wiring diagram in this section).
- Remove the needle adapter set, and apply silicone sealant to the seals of the connector for waterproofing.  
**Sealant - Kawasaki Bond (Silicone Sealant): 56019-120**
- ★ If the wiring is good, check the sensor resistance.

### Sensor Resistance Inspection

- Remove the inlet air temperature sensor (see Inlet Air Temperature Sensor Removal in this chapter).
- Suspend the sensor [A] in a container of machine oil so that the heat-sensitive portion is submerged.
- Suspend a thermometer [B] with the heat-sensitive portion [C] located in almost the same depth with the sensor.

#### NOTE

- *The sensor and thermometer must not touch the container side or bottom.*
- Place the container over a source of heat and gradually raise the temperature of the oil while stirring the oil gently for even temperature.
- Using a digital meter, measure the internal resistance of the sensor across the terminals at the temperatures shown in the table.

#### Inlet Air Temperature Sensor Resistance

**Standard: 2.09 ~ 2.81 kΩ at 20°C (68°F)**

**About 0.322 kΩ at 80°C (176°F) (reference valve)**

- ★ If the measurement is out of the range, replace the sensor.
- ★ If the measurement is within the specified, replace the ECU (see ECU Removal/Installation in this chapter).

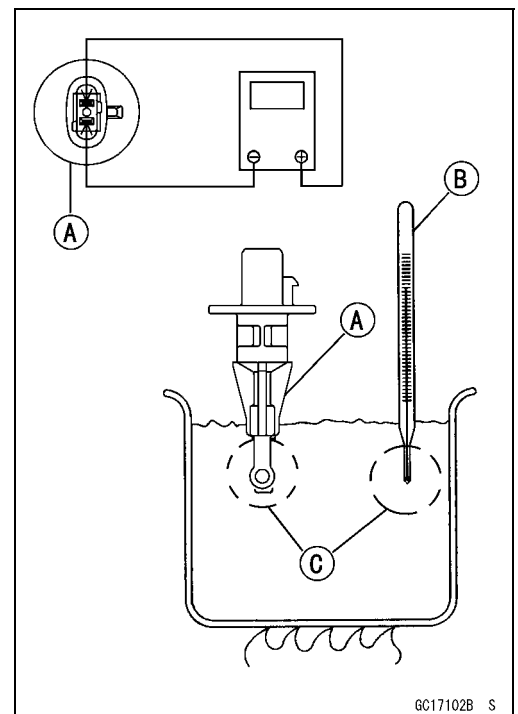

GC17102B S

### 3-56 FUEL SYSTEM (DFI)

#### Inlet Air Temperature Sensor (Service Code 13)

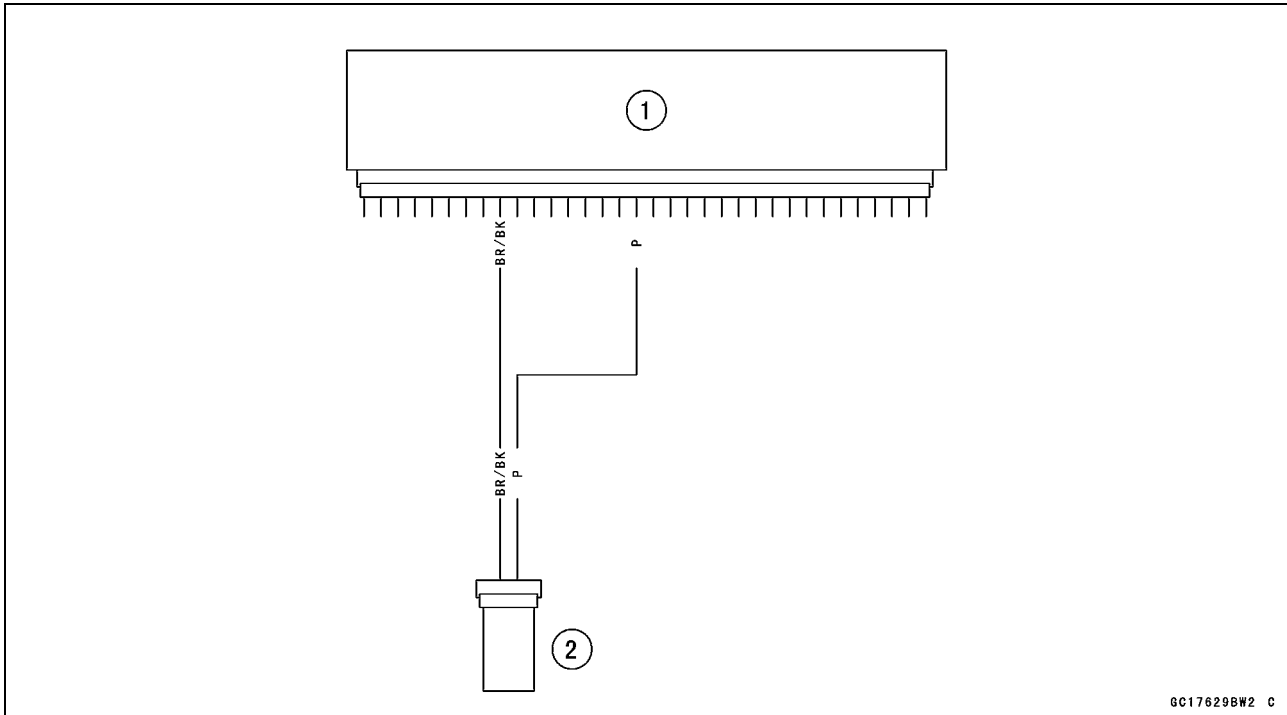

- 1. ECU
- 2. Inlet Air Temperature Sensor

**Water Temperature Sensor (Service Code 14)**

*Removal/Installation*

<b>CAUTION</b>
<b>Never drop the sensor, especially on a hard surface. Such a shock to the sensor can damage it.</b>

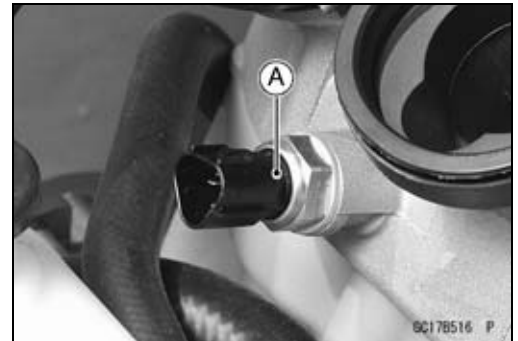

- Drain the coolant (see Coolant Change in the Periodic Maintenance chapter).
- Remove the throttle body assy (see Throttle Body Assy Removal in this chapter).
- Remove:
  - Connector
  - Water Temperature Sensor [A]
- Apply silicone sealant to the threads of the water temperature sensor and tighten it.
 

**Sealant - Kawasaki Bond (Silicone Sealant): 56019-120**

**Torque - Water Temperature Sensor: 25 N·m (2.5 kgf·m, 18 ft·lb)**
- Fill the engine with coolant and bleed the air from the cooling system (see Coolant Filling in the Cooling System chapter).

*Output Voltage Inspection*

**NOTE**

○ Be sure the battery is fully charged.

- Remove the ECU (see ECU Removal in this chapter). Do not disconnect the connectors.
- Connect a digital voltmeter [A] to the ECU connectors [B], with the needle adapter set.

**Special Tool - Needle Adapter Set: 57001-1457**

**Water Temperature Sensor Output Voltage Connections to ECU**

- Meter (+) → O lead (terminal 9)**
- Meter (-) → BR/BK lead (terminal 28)**

- Measure the sensor output voltage with the engine stopped and the connector joined.
- Turn the ignition switch ON.

**Output Voltage at ECU**

**Standard: About 2.80 ~ 2.97 V at 20°C (68°F)**

**NOTE**

○ The output voltage changes according to the coolant temperature in the engine.

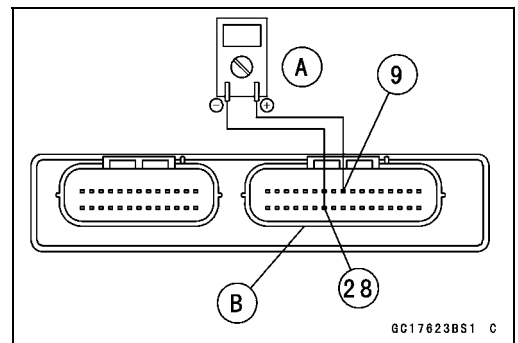

## 3-58 FUEL SYSTEM (DFI)

### Water Temperature Sensor (Service Code 14)

- Turn the ignition switch OFF.
- ★ If the output voltage is out of the specified, check the ECU for its ground, and power supply (see ECU Power Supply Inspection in this chapter). If the ground and power supply are good, replace the ECU (see ECU Removal/Installation in this chapter).
- ★ If the output voltage is far out of the specified (e.g. when the wiring is open, the voltage is about 5 V.), check the wiring (see wiring diagram in this section).
- ★ If the wiring is good, check the water temperature sensor resistance.
- Remove the needle adapter set, and apply silicone sealant to the seals of the connector for waterproofing.

**Sealant - Kawasaki Bond (Silicone Sealant): 56019-120**

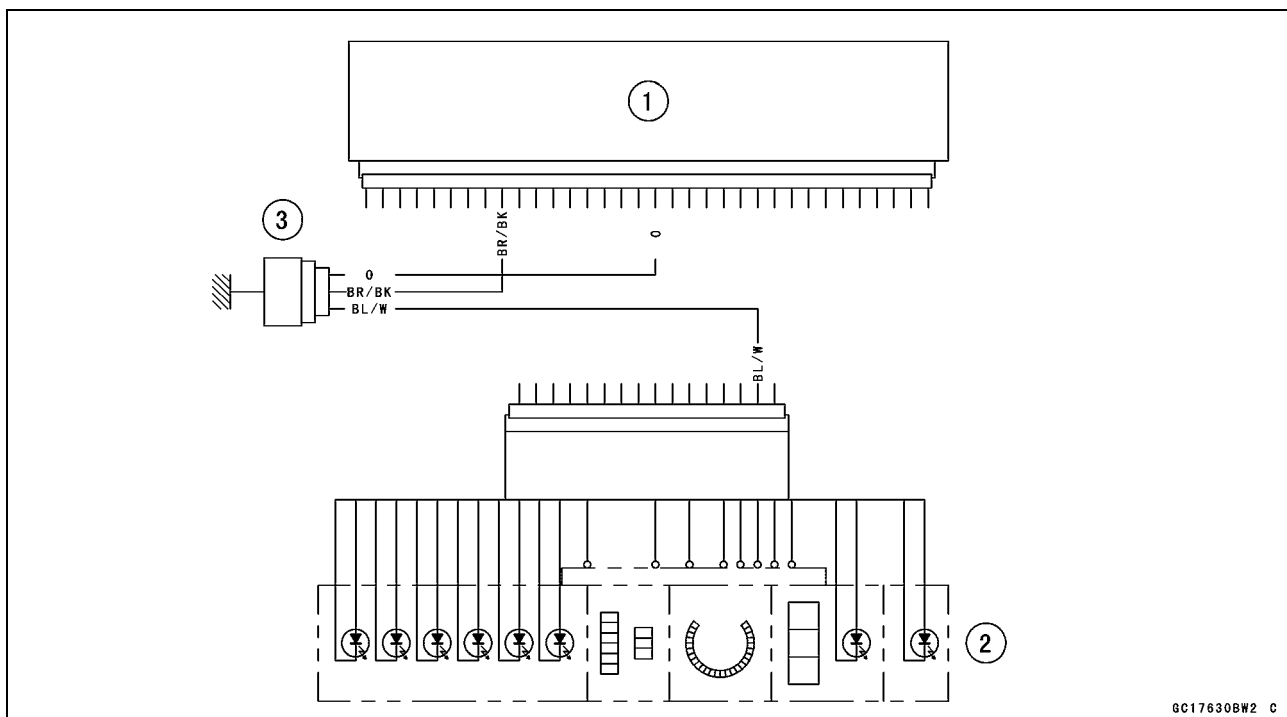

1. ECU
2. Meter Unit
3. Water Temperature Sensor

#### *Sensor Resistance Inspection*

- Remove the water temperature sensor (see Removal/Installation in this chapter).
- Refer to the Electrical System chapter for water temperature sensor inspection.

**Atmospheric Pressure Sensor (Service Code 15)**

**CAUTION**

**Never drop the sensor, especially on a hard surface. Such a shock to the sensor can damage it.**

*Removal*

- Turn the ignition switch OFF.
- Remove:
  - Air Cleaner Housing (see Air Cleaner Housing Removal in this chapter)
  - Atmospheric Pressure Sensor Connector [A]
  - Damper [B]
  - Atmospheric Pressure Sensor [C]

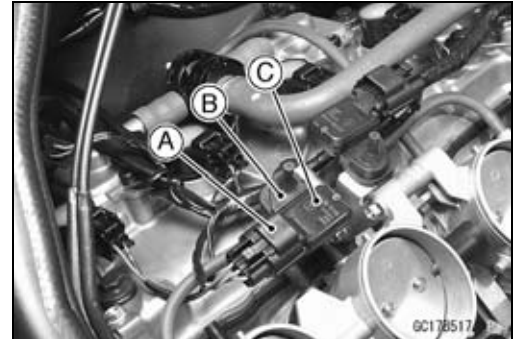

*Installation*

**NOTE**

○The atmospheric pressure sensor is the same part as the inlet air pressure sensor except that the inlet air pressure sensor has a inlet air pressure hose and different wiring.

- Put the atmospheric pressure sensor in the stay plate of throttle body assy.

*Input Voltage Inspection*

**NOTE**

○Be sure the battery is fully charged.  
 ○The inspection is the same as "Input Voltage Inspection" of the throttle sensor and the inlet air pressure sensor.

- Turn the ignition switch OFF.
- Remove the ECU (see ECU Removal in this chapter). Do not disconnect the ECU connectors.
- Connect a digital voltmeter [A] to the connector [B], with the needle adapter set.

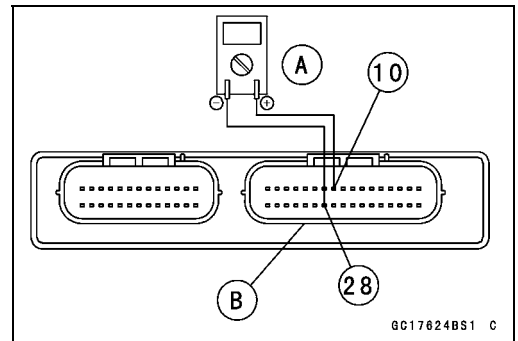

**Special Tool - Needle Adapter Set: 57001-1457**

**Atmospheric Pressure Sensor Input Voltage**

**Connections to ECU**

- Meter (+) → BL lead (terminal 10)
- Meter (-) → BR/BK lead (terminal 28)

- Measure the input voltage with the engine stopped, and with the connectors joined.
- Turn the ignition switch ON.

**Input Voltage at ECU**

**Standard: DC 4.75 ~ 5.25 V**

- ★If the reading of input voltage is less than the standard range, check the ECU for its ground, and power supply (see ECU Power Supply Inspection in this chapter). If the ground and power supply are good, replace the ECU (see ECU Removal/Installation in this chapter).

## 3-60 FUEL SYSTEM (DFI)

### Atmospheric Pressure Sensor (Service Code 15)

- ★ If the reading is within the standard range, check the input voltage again at the sensor connector.
- Remove the air cleaner housing (see Air Cleaner Housing Removal in this chapter).
- Disconnect the atmospheric pressure sensor connector and connect the harness adapter [A] between the main harness connector and atmospheric pressure sensor connector.
- Connect a digital meter to the harness adapter leads. Atmospheric Pressure Sensor [B]

**Special Tool - Sensor Harness Adapter: 57001-1561**

#### Atmospheric Pressure Sensor Input Voltage

##### Connections to Sensor

Meter (+) → BL lead [C]

Meter (-) → BR/BK lead [D]

- Measure the input voltage with the engine stopped, and with the connector joined.
- Turn the ignition switch ON.

#### Input Voltage at Sensor Connector

**Standard: DC 4.75 ~ 5.25 V**

- ★ If the reading is out of the standard range, check the wiring (see wiring diagram in this section).
- ★ If the reading is good, the input voltage is normal. Check the output voltage.
- Turn the ignition switch OFF.

#### Output Voltage Inspection

- Measure the output voltage at the ECU in the same way as input voltage inspection.  
Digital Meter [A]  
ECU Connector [B]

#### Atmospheric Pressure Sensor Output Voltage

##### Connections to ECU

Meter (+) → G/W lead (terminal 25)

Meter (-) → BR/BK lead (terminal 28)

#### Output Voltage

**Usable Range: DC 3.80 ~ 4.20 V at the standard atmospheric pressure (101.32 kPa, 76 cmHg abs.)**

#### NOTE

- The output voltage changes according to the local atmospheric pressure.
  - The atmospheric sensor output voltage is based on a nearly perfect vacuum in the small chamber of the sensor. So, the sensor indicates absolute atmospheric pressure.
- ★ If the output voltage is within the usable range, check the ECU for its ground, and power supply (see ECU Power Supply Inspection in this chapter). If the ground and power supply are good, replace the ECU (see ECU Removal/Installation in this chapter).

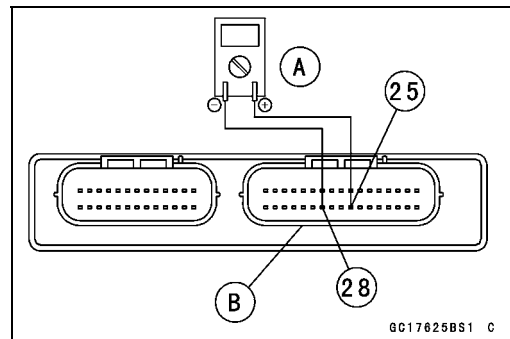
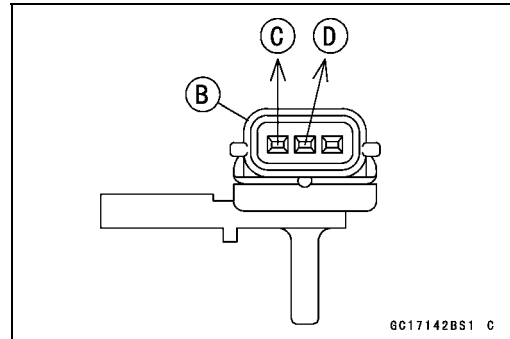
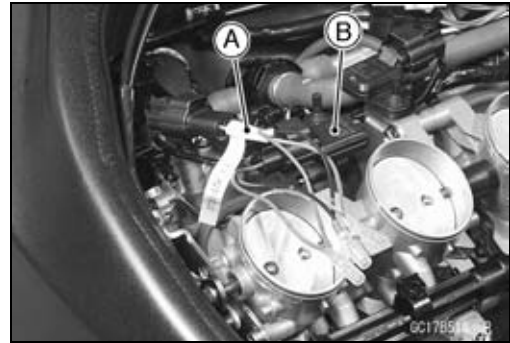

**Atmospheric Pressure Sensor (Service Code 15)**

- ★ If the output voltage is far out of the usable range, check the output voltage at the sensor connector [A] (when the wiring is open, the output voltage is about 1.8 V.).
- Connect a digital meter to the harness adapter leads. Atmospheric Pressure Sensor [B]

**Special Tool - Sensor Harness Adapter: 57001-1561**

**Atmospheric Pressure Sensor Output Voltage**

**Connections to Sensor**

- Meter (+) → G/W lead [C]
- Meter (-) → BR/BK lead [D]

**Output Voltage at Sensor**

**Usable Range: DC 3.80 ~ 4.20 V at the standard atmospheric pressure (101.32 kPa, 76 cmHg abs.)**

- ★ If the output voltage is normal, check the wiring for continuity (see wiring diagram in this section).
- ★ If the output voltage is out of the usable range, replace the sensor.

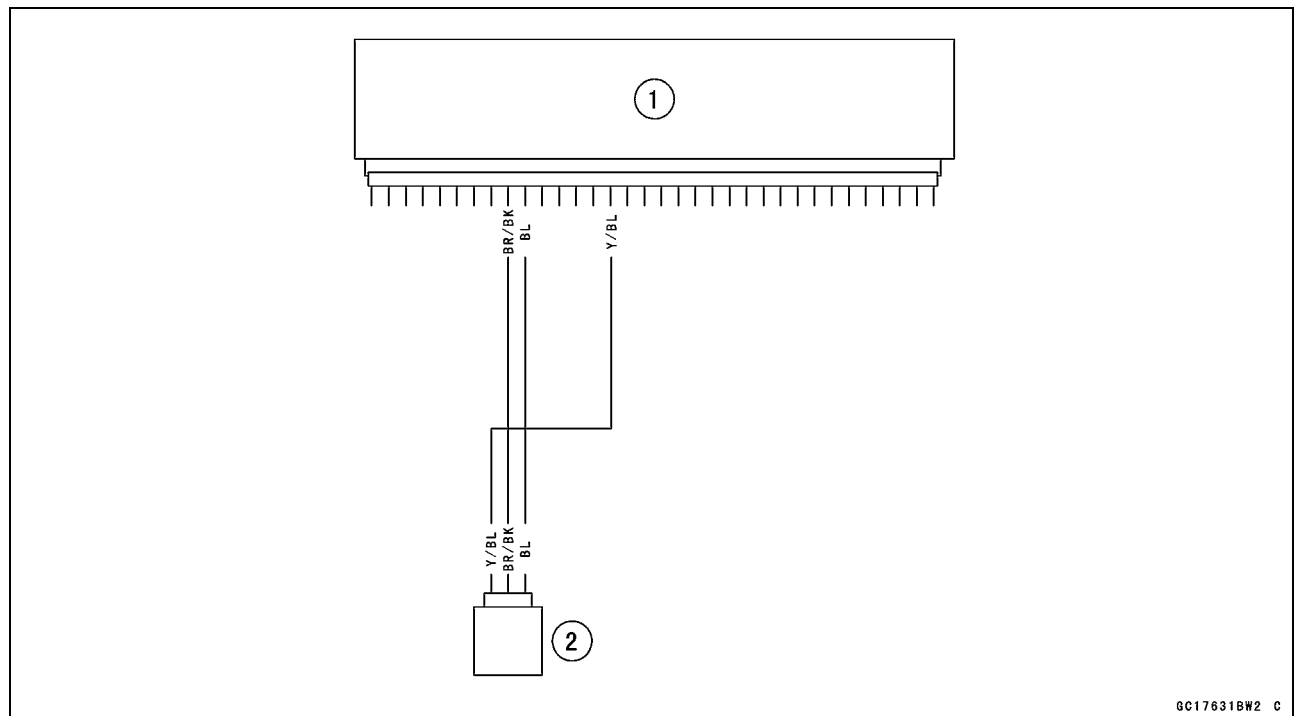
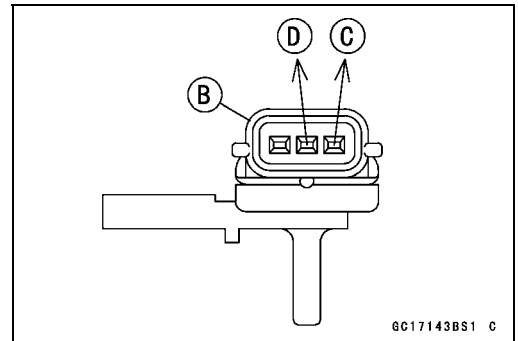
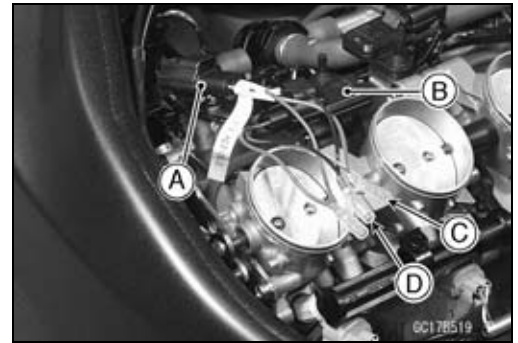

1. ECU
2. Atmospheric Pressure Sensor

- ★ If you need to check the atmospheric pressure sensor for various altitudes other than sea level, check the output voltage as follows:
  - Determine the local altitude (Elevation).

### 3-62 FUEL SYSTEM (DFI)

#### Atmospheric Pressure Sensor (Service Code 15)

- ★If you know the local atmospheric pressure using a barometer, substitute the atmospheric pressure for throttle vacuum pressure in the inlet air pressure sensor chart (see Inlet Air Pressure Sensor section in this chapter). And get the usable range of the atmospheric pressure sensor output voltage and check if output voltage is within the standard or not in the same way as Output Voltage Inspection of the inlet air pressure sensor.
- ★If you know the local altitude, use the following chart.

#### Atmospheric Pressure/Altitude Relationship

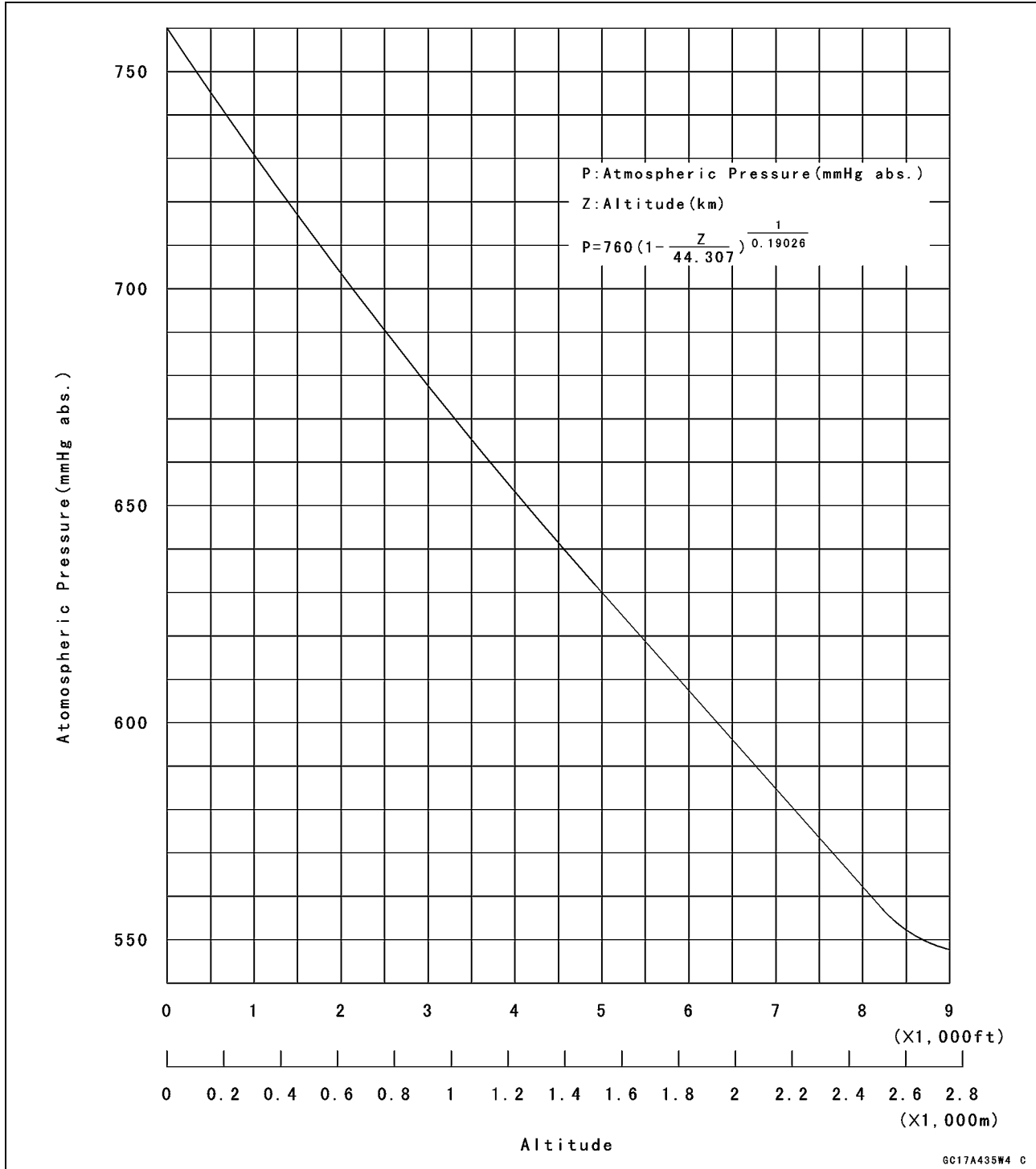

**Crankshaft Sensor (Service Code 21)**

*Crankshaft Sensor Removal/Installation*

- See the Crankshaft Sensor Removal/Installation in the Electrical System chapter.

*Crankshaft Sensor Inspection*

- The crankshaft has no power source, and when the engine stops, the crankshaft generates no signals.
- Crank the engine and measure the peak voltage of the crankshaft sensor (see Crankshaft Sensor Peak Voltage Inspection in the Electrical System chapter) in order to check the sensor.
- Check the wiring for continuity (see wiring diagram in this section).

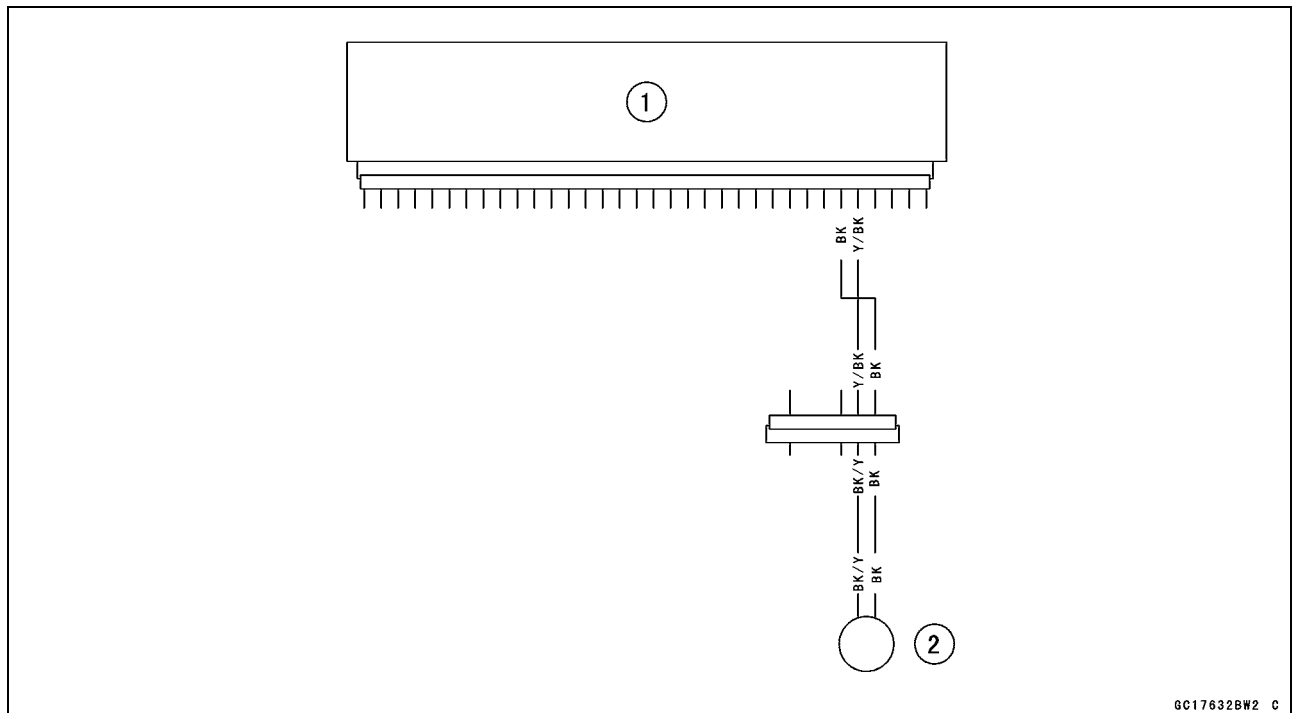

GC17632BW2 C

1. ECU
2. Crankshaft Sensor

## 3-64 FUEL SYSTEM (DFI)

### Camshaft Position Sensor (Service Code 23)

#### *Camshaft Position Sensor Removal/Installation*

The camshaft position sensor detects the position of the camshaft, and distinguishes the cylinder.

- See the Camshaft Position Sensor Removal/Installation in the Electric System chapter.

#### *Camshaft Position Sensor Inspection*

- The camshaft position sensor have no power source, and when the engine stops, the camshaft position sensor generates no signal.
- Crank the engine and measure the peak voltage of the camshaft position sensor (see Camshaft Position Sensor Peak Voltage Inspection in the Electrical System chapter) in order to check the sensor.
- Check the wiring for continuity (see wiring diagram in this section).

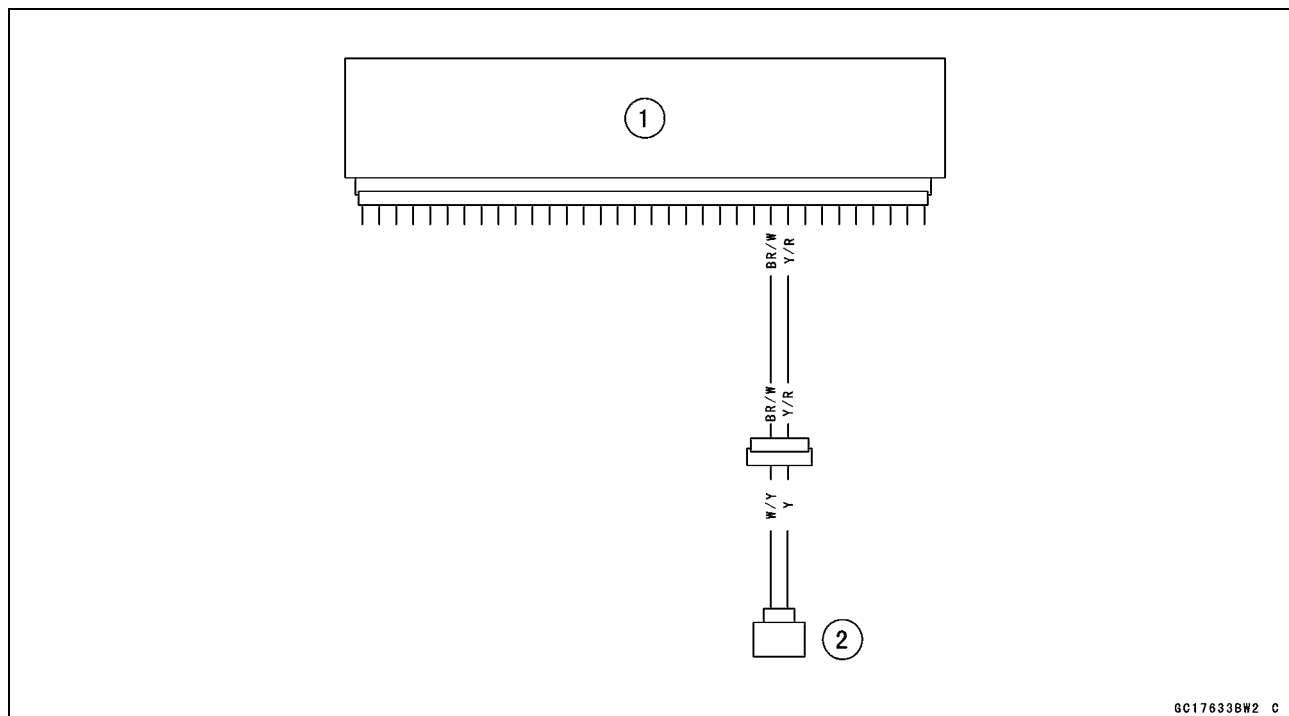

GC176338W2 C

1. ECU
2. Camshaft Position Sensor

## Speed Sensor (Service Code 24)

### Speed Sensor Removal/Installation

- See the Speed Sensor Removal/Installation in the Electrical System chapter.

### Speed Sensor Inspection

- See the Speed Sensor Inspection in the Electrical System chapter.

### Input Voltage Inspection

#### NOTE

○ Be sure the battery is fully charged.

- Turn the ignition switch OFF.
- Remove the fuel tank temporarily (see Fuel Tank Removal in this chapter).
- Disconnect the speed sensor connector [A], and connect the harness adapter [B] between the harness connector and speed sensor connector.
- Connect a digital meter to the harness adapter leads.

**Special Tool - Speed Sensor Measuring Adapter: 57001-1635**

#### Speed Sensor Input Voltage

##### Connector to Sensor

Meter (+) → P lead [C]

Meter (-) → BK/Y lead [D]

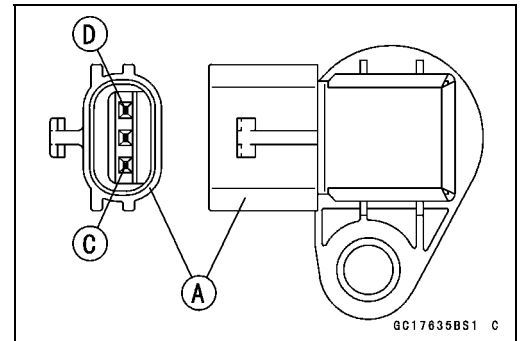
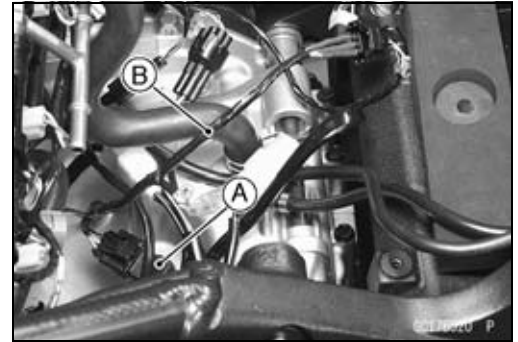

- Measure the sensor input voltage with the engine stopped, and with the connector joined.
- Turn the ignition switch ON.

#### Input Voltage at Sensor

**Standard: About DC 9 ~ 11 V**

★ If the reading is out of the range, check the wiring (see wiring diagram in this section), and meter (see Electronic Combination Meter Assembly Inspection in the Electrical System chapter).

★ If the reading is good, check the output voltage.

- Turn the ignition switch OFF.

### Output Voltage Inspection

- Before this inspection, inspect the input voltage (see Input Voltage Inspection in this section).

#### NOTE

○ Be sure the battery is fully charged.

- Turn the ignition switch OFF.

# 3-66 FUEL SYSTEM (DFI)

## Speed Sensor (Service Code 24)

- Disconnect the speed sensor connector [A], and connect the harness adapter [B] between the harness connector and speed sensor connector.
- Connect a digital meter to the harness adapter leads.

**Special Tool - Speed Sensor Measuring Adapter: 57001-1635**

### Speed Sensor Output Voltage

#### Connections to Sensor

Meter (+) → Y lead [C]

Meter (-) → BK/Y lead [D]

- Measure the sensor output voltage with the engine stopped, and with the connector joined.
- Turn the ignition switch ON.

### Output Voltage at Sensor

**Standard: About DC 0.05 ~ 0.07 V**

### NOTE

○ If you can rotate the drive shaft, the output voltage will be raise.

★ If the reading is out of the range, check the speed sensor (see Speed Sensor Inspection in the Electrical System chapter) and the wiring to ECU (see wiring diagram in this section).

★ If the reading, speed sensor and wiring are good, replace the ECU (see ECU Removal/Installation in this chapter).

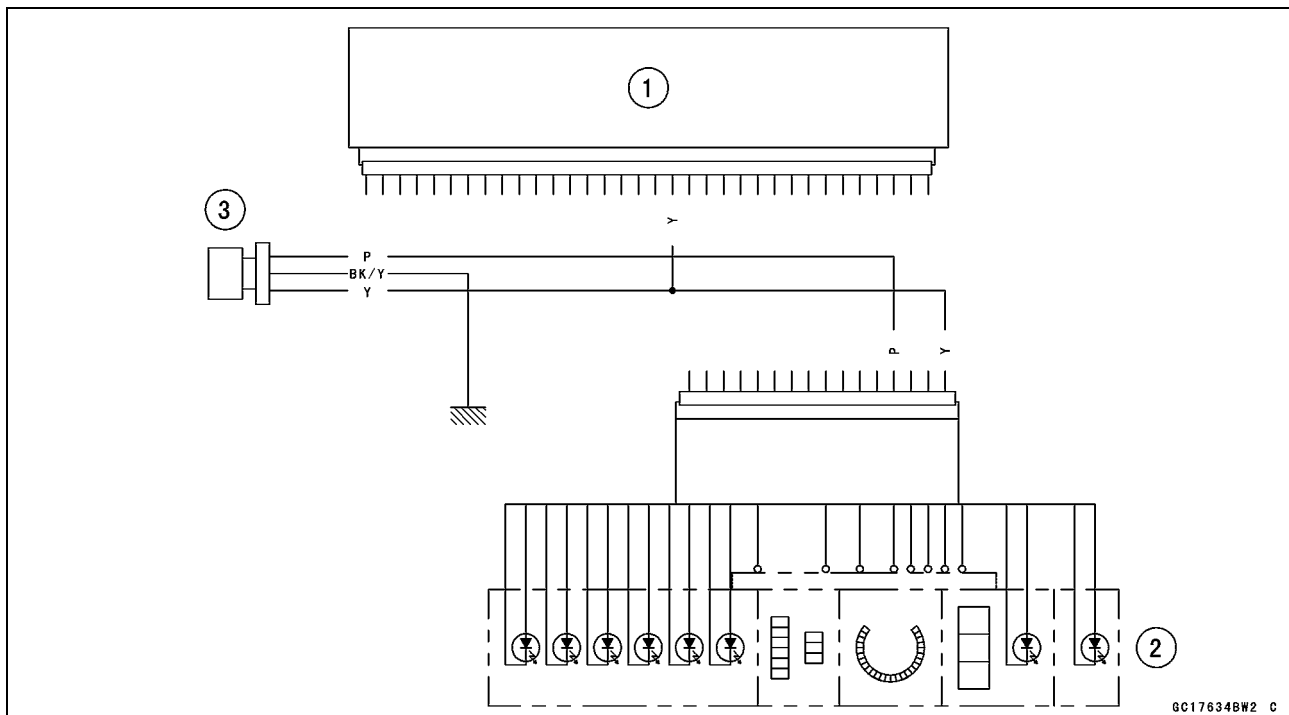
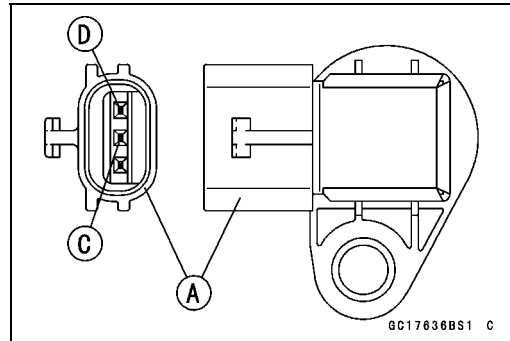
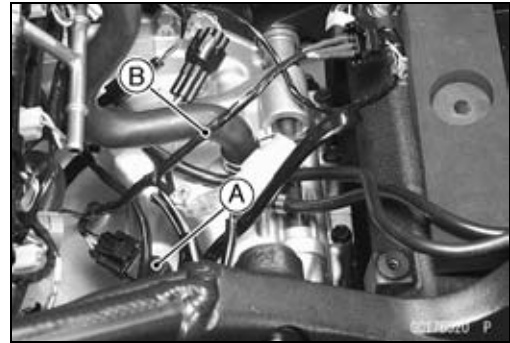

1. ECU
2. Meter Unit
3. Speed Sensor

**Vehicle-down Sensor (Service Code 31)**

This sensor has a weight [A] with two magnets inside, and sends a signal to the ECU. But when the motorcycle banks 60 ~ 70° or more to either side (in fact falls down), the weight turns and shuts off the signal. The ECU senses this change, and stops the fuel pump, the fuel injectors, and the ignition system.

Hall IC [B]

When the motorcycle is down, the ignition switch is left ON. If the starter button is pushed, the electric starter turns but the engine doesn't start. To start the engine again, raise the motorcycle, turn the ignition switch OFF, and then ON. When the ignition switch is turned ON, current flows through the latch-up circuit and the transistor in the circuit is turned ON to unlock the latch-up circuit.

Vehicle-down Sensor [A]

Ground Terminal BR/BK [B]

Output Terminal Y/G [C]

Power Source Terminal BL [D]

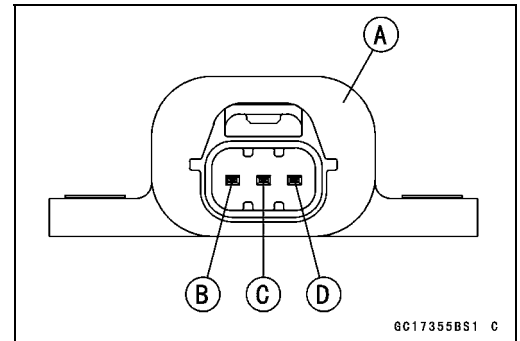
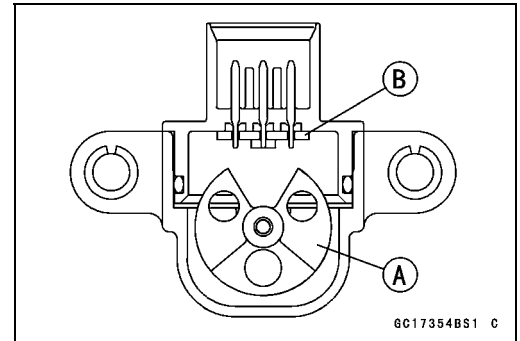

*Removal*

<b>CAUTION</b>
<b>Never drop the vehicle-down sensor, especially on a hard surface. Such a shock to the sensor can damage it.</b>

- Remove:
  - Front Seat (see Front Seat Removal in the Frame chapter)
  - Connector [A]
  - Bolts [B]
  - Vehicle-down Sensor [C] and collars

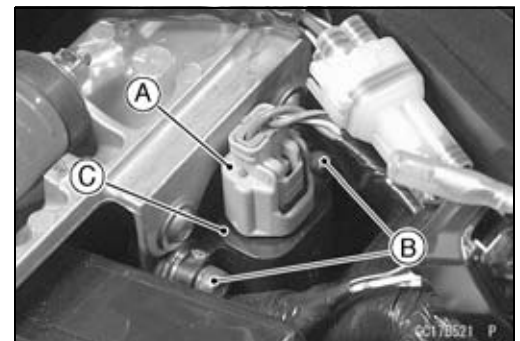

*Installation*

- The UP mark [A] of the sensor should face upward.

<b>⚠ WARNING</b>
<b>Incorrect installation of the vehicle-down sensor could cause sudden loss of engine power. The rider could lose balance during certain riding situations, like leaning over in a turn, with the potential for an accident resulting in injury or death. Ensure that the sensor is held in place by the fuel tank bracket.</b>

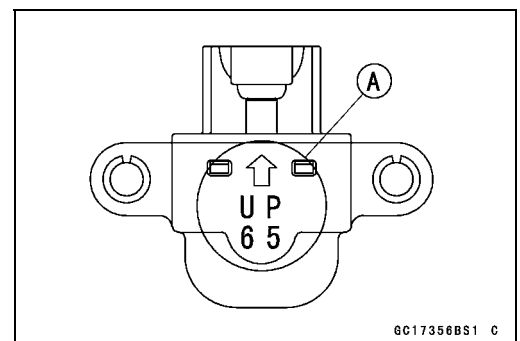

*Inspection*

**NOTE**

○Be sure the battery is fully charged.

- Remove:
  - Front Seat (see Front Seat Removal in the Frame chapter)

# 3-68 FUEL SYSTEM (DFI)

## Vehicle-down Sensor (Service Code 31)

- Connect a digital volt meter [A] to the connector of the vehicle-down sensor [B], with the needle adapter set [C].

### Vehicle-down Sensor Power Source Voltage

#### Connections to Sensor

Meter (+) → BL lead [D]

Meter (-) → BR/BK lead [E]

- Turn the ignition switch ON, and measure the power source voltage with the connector joined.

### Power Source Voltage at Sensor

Standard: DC 4.75 ~ 5.25 V

- Turn the ignition switch OFF.
- ★ If there is no voltage, check the following:
  - Battery (see Charging Condition Inspection in the Electrical System chapter)
  - ECU Fuse 15 A (see Fuse Inspection in the Electrical System chapter)
- ★ If the power source is normal, check the output voltage.

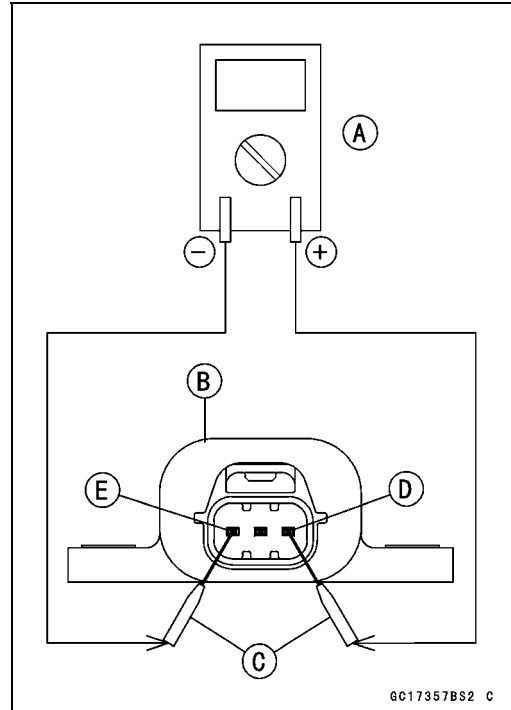

- Turn the ignition switch OFF.
- Remove the sensor (see Removal in this chapter).
- Connect a digital volt meter [A] to the connector, with needle adapter set [B].

Special Tool - Needle Adapter Set: 57001-1457

### Vehicle-down Sensor Output Voltage

#### Connections to Sensor

Meter (+) → Y/G lead [C]

Meter (-) → BR/BK lead [D]

- Hold the sensor vertically.
- Turn the ignition switch ON, and measure the output voltage with the connector joined.
- Tilt the sensor 60 ~ 70° or more [E] right or left, then hold the sensor almost vertical with the arrow mark pointed up, and measure the output voltage.

### Output Voltage at Sensor

Standard: with sensor arrow mark pointed up: 3.55 ~ 4.45 V

with sensor tilted 60 ~ 70° or more right or left: 0.65 ~ 1.35 V

### NOTE

○ If you need to test again, turn the ignition switch OFF, and then ON.

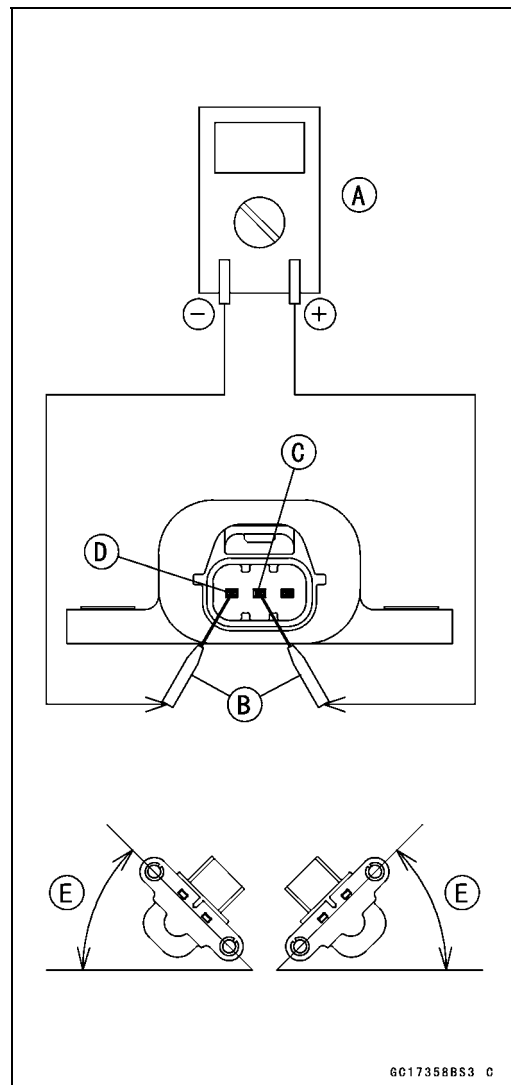

## Vehicle-down Sensor (Service Code 31)

- Turn the ignition switch OFF.
- Remove the needle adapter set, and apply silicone sealant to the seals of the connector for waterproofing.

**Sealant - Kawasaki Bond (Silicone Sealant): 56019-120**

- ★ If the output voltage is out of the specified, replace the vehicle-down sensor.

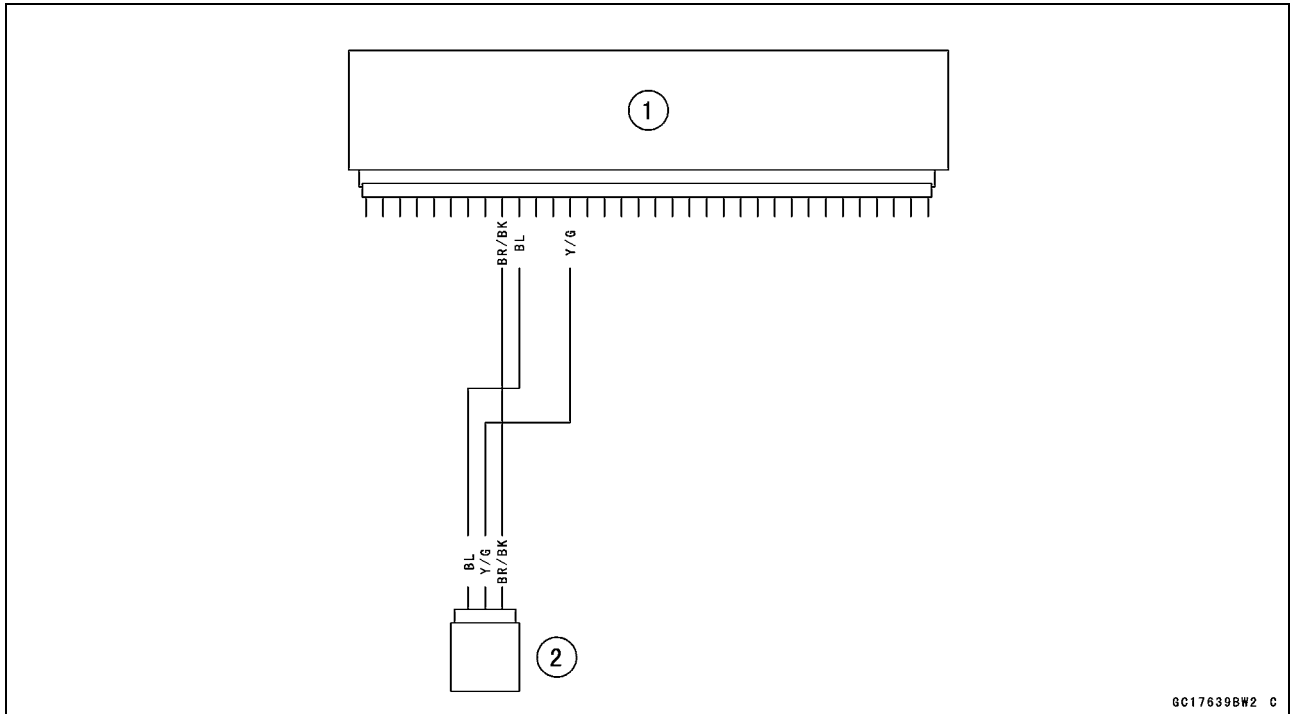

GC17639BW2 C

1. ECU
2. Vehicle-down Sensor

## 3-70 FUEL SYSTEM (DFI)

### Subthrottle Sensor (Service Code 32)

#### Subthrottle Sensor Removal/Adjustment

#### CAUTION

Do not remove or adjust the subthrottle sensor [A] since it has been adjusted and set with precision at the factory.

Never drop the throttle body assy, especially on a hard surface. Such a shock to the sensor can damage it.

Subthrottle Sensor Connector [B]

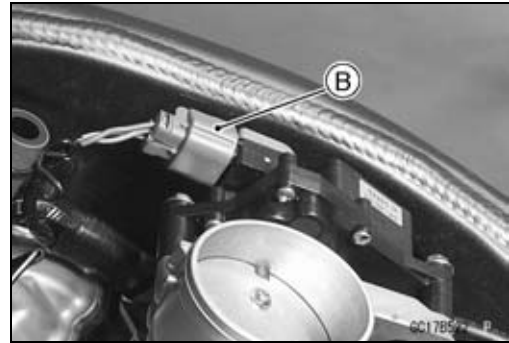

#### Input Voltage Inspection

#### NOTE

○Be sure the battery is fully charged.

- Turn the ignition switch OFF.
- Remove the ECU (see ECU Removal in this chapter). Do not disconnect the ECU connectors.
- Connect a digital voltmeter [A] to the connector [B], using the needle adapter set.

Special Tool - Needle Adapter Set: 57001-1457

#### Subthrottle Sensor Input Voltage

##### Connections to ECU Connector

Meter (+) → BL lead (terminal 10)

Meter (-) → BR/BK lead (terminal 28)

- Measure the input voltage with the engine stopped, and with the connectors joined.
- Turn the ignition switch ON.

#### Input Voltage at ECU Connector

Standard: DC 4.75 ~ 5.25 V

- Turn the ignition switch OFF.
- ★ If the reading of input voltage is less than the standard, check the ECU for its ground, power supply and wiring shorted.
- ★ If the input voltage is within the standard range, check the input voltage at the subthrottle sensor connector.
- Remove the throttle body assembly temporarily (see Throttle Body Assy Removal in this chapter).

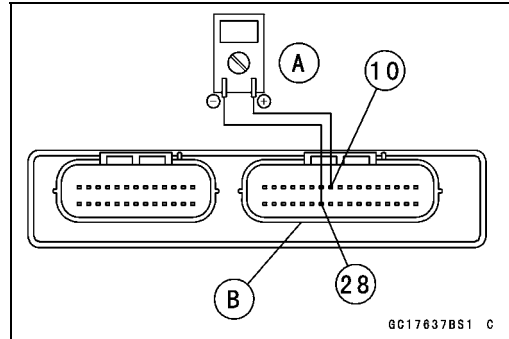

**Subthrottle Sensor (Service Code 32)**

- Disconnect the subthrottle sensor connector [A] and connect the harness adapter [B] between the harness connector and sub throttle sensor connector.
- Connect a digital meter to the harness adapter leads.  
**Special Tool - Throttle Sensor Setting Adapter: 57001-1538**

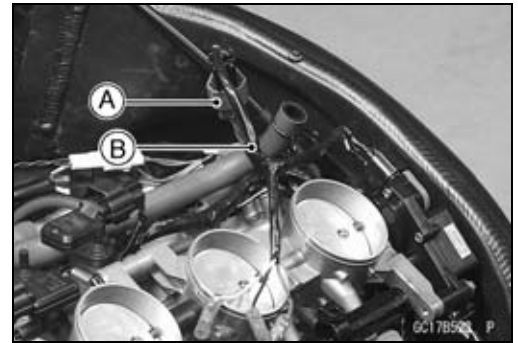

**Subthrottle Sensor Input Voltage**

**Connections to Sensor**

- Meter (+) → BL lead
- Meter (-) → BR/BK lead

- Install the throttle body assy (see Throttle Body Assy Installation in this chapter).
- Measure the sensor input voltage with the engine stopped, and with the connector joined.
- Turn the ignition switch ON.

**Input Voltage at Sensor**

**Standard: DC 4.75 ~ 5.25 V**

- Turn the ignition switch OFF.
- ★ If the reading is out of the range, check the wiring (see wiring diagram in this section).
- ★ If the reading is good, check the output voltage of the sensor.

**Output Voltage Inspection**

- Measure the output voltage at the ECU in the same way as input voltage inspection.  
 Digital Voltmeter [A]  
 Connectors [B]

**Special Tool - Needle Adapter Set: 57001-1457**

**Subthrottle Sensor Output Voltage**

**Connections to ECU**

- Meter (+) → BR lead (terminal 24)
- Meter (-) → BR/BK lead (terminal 28)

- Turn the ignition switch ON.
- Measure the output voltage when the subthrottle valve is fully opened or completely closed by hand.

**Output Voltage at ECU**

**Standard: DC 1.08 ~ 4.60 V (at subthrottle valve full opening to closing)**

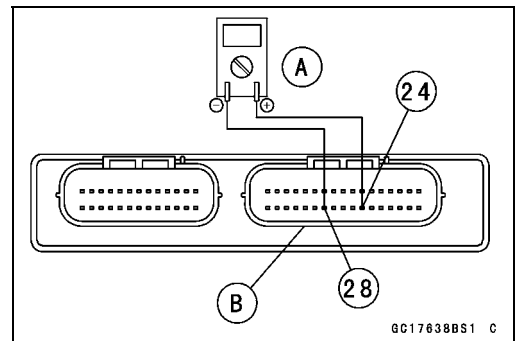

**CAUTION**

**Do not remove or adjust the subthrottle sensor. It has been adjusted and set with precision at the factory.**  
**Never drop the throttle body assy can especially on a hard surface. A shock to the sensor can damage it.**

## 3-72 FUEL SYSTEM (DFI)

### Subthrottle Sensor (Service Code 32)

- ★ If the output voltage is within the standard range, check the ECU for a good ground, and power supply (see ECU Power Supply Inspection in this chapter). If the ground and power supply are good, replace the ECU (see ECU Removal/Installation in this chapter).
- ★ If the output voltage is far out of the standard range (e.g. when the wiring is open, the reading is 0 V.), check the output voltage again at the sensor connector.
- Disconnect the subthrottle sensor connector [A] and connect the harness adapter [B] between the harness connector and subthrottle sensor connector.
- Connect a digital meter to the harness adapter leads.

**Special Tool - Throttle Sensor Setting Adapter: 57001-1538**

#### Subthrottle Sensor Output Voltage

##### Connections to Sensor

**Meter (+) → BR lead**

**Meter (-) → BR/BK lead**

- Measure the sensor output voltage with the engine stopped, and with the connector joined.
- Turn the ignition switch ON.
- Measure the output voltage when the subthrottle valve is fully opened or completely closed by hand.

#### Output Voltage at Sensor

**Standard: DC 1.08 ~ 4.60 V (at subthrottle valve full opening to closing)**

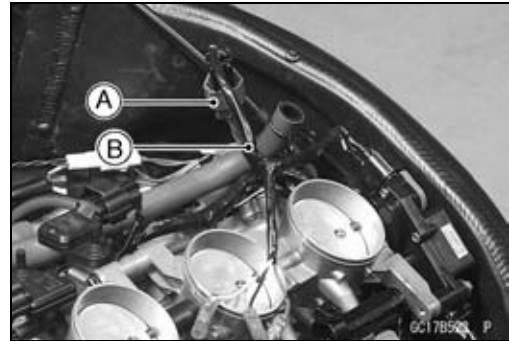

#### CAUTION

**Do not remove or adjust the subthrottle sensor. It has been adjusted and set with precision at the factory.**

**Never drop the throttle body assy, especially on a hard surface. A shock to the sensor can damage it.**

- After subthrottle sensor voltage inspection, remove the harness adapter.
- ★ If the reading is out of the standard range, inspect the throttle sensor resistance.
- ★ If the output voltage is normal, check the wiring for continuity (see wiring diagram in this section).

**Subthrottle Sensor (Service Code 32)**

*Resistance Inspection*

- Turn the ignition switch OFF.
- Disconnect the subthrottle sensor connector.
- Connect a digital meter [A] to the subthrottle sensor connector [B].
- Measure the subthrottle sensor resistance.

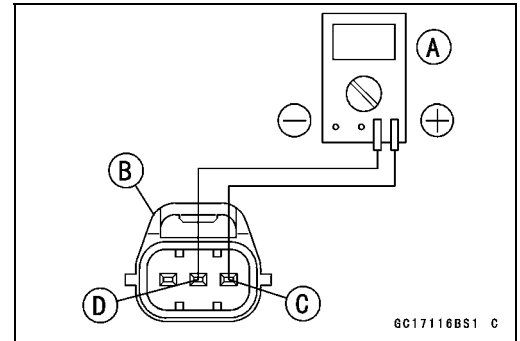

**Subthrottle Sensor Resistance**

**Connections:** BL lead [C] ↔ BR/BK lead [D]

**Standard:** 4 ~ 6 kΩ

- ★ If the reading is out of the range, replace the throttle body assy (see Throttle Body Assy Removal/Installation in this chapter).
- ★ If the reading is within the range, but the problem still exists, replace the ECU (see ECU Removal/Installation in this chapter).

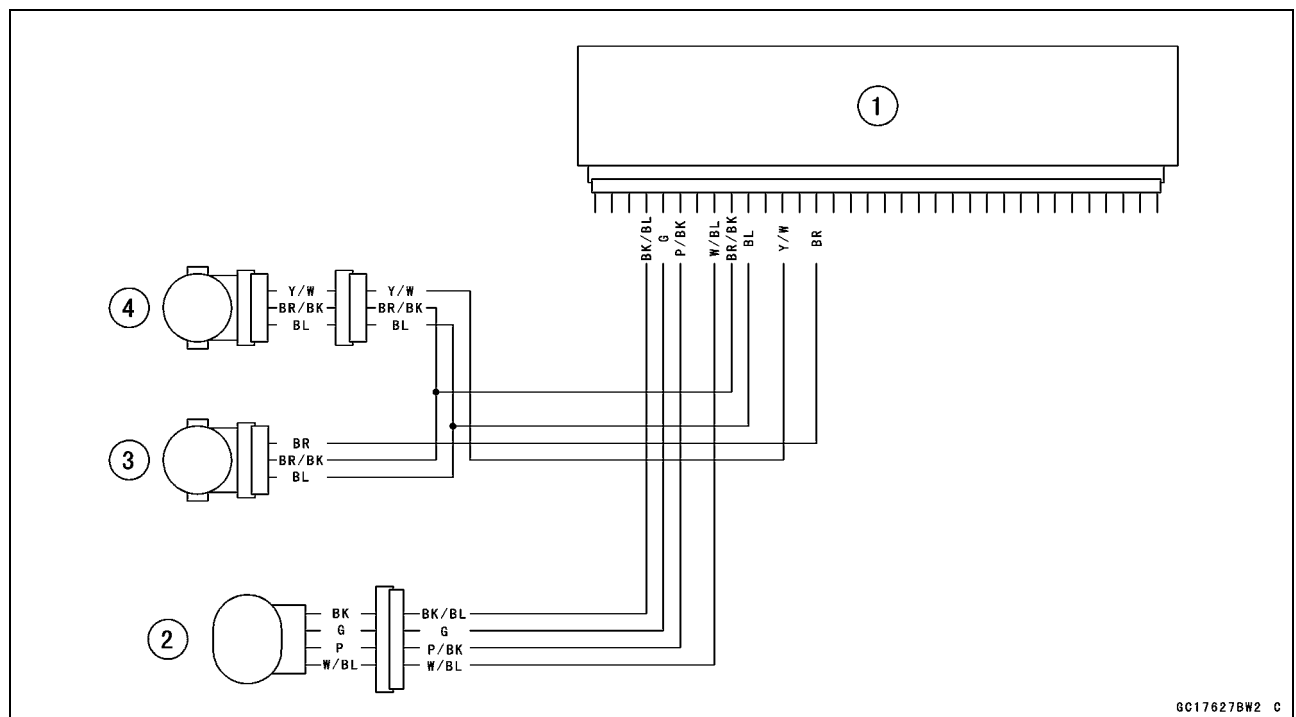

1. ECU
2. Subthrottle Valve Actuator
3. Subthrottle Sensor
4. Main Throttle Sensor

### 3-74 FUEL SYSTEM (DFI)

#### Exhaust Butterfly Valve Actuator Sensor (Service Code 34)

##### Exhaust Butterfly Valve Actuator Sensor Inspection

- Turn the ignition switch OFF.
- Disconnect the exhaust butterfly valve actuator sensor connector.
- Connect a digital meter [A] to the exhaust butterfly valve actuator sensor connector [B].
- Measure the exhaust butterfly valve actuator sensor resistance.

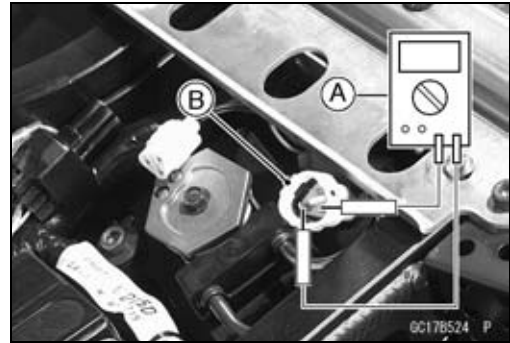

##### Exhaust Butterfly Valve Actuator Sensor Resistance

Connections: W lead [C] ↔ BK lead [D]

Standard: 4 ~ 6 kΩ

- ★ If the reading is out of the range, replace the exhaust butterfly valve actuator (see Exhaust Butterfly Valve Actuator Removal/Installation in this chapter).

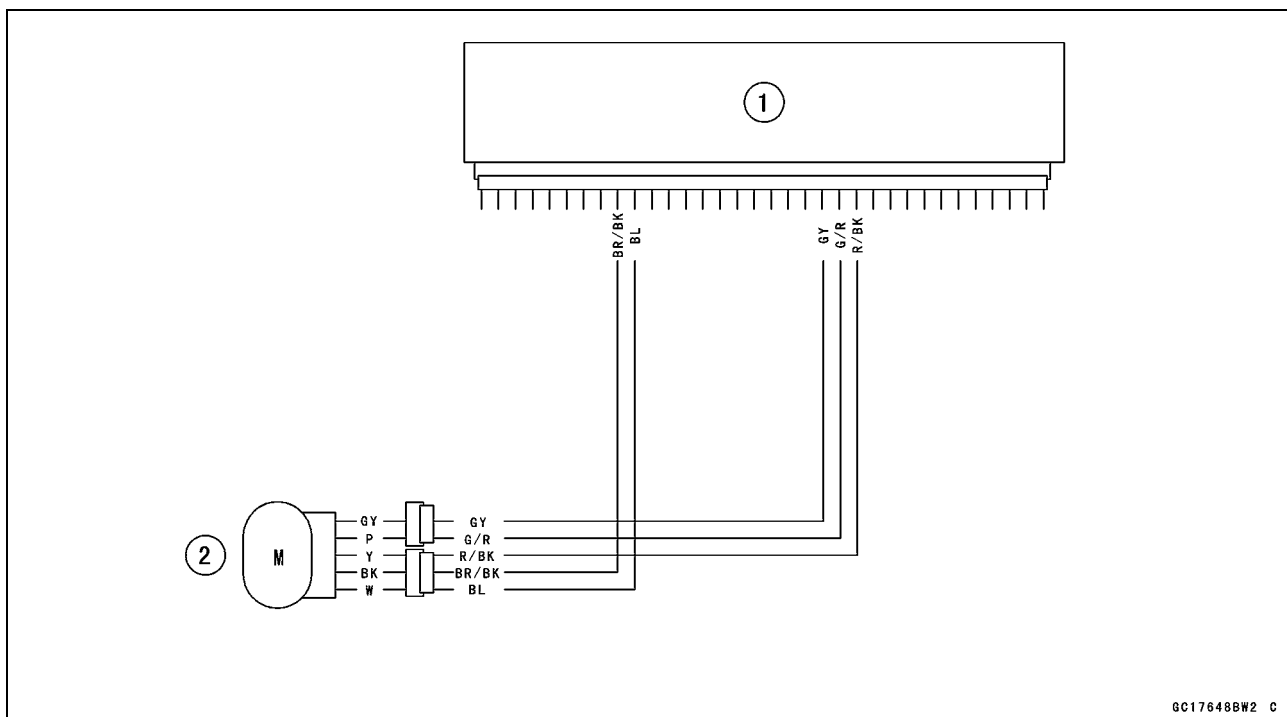

1. ECU
2. Exhaust Butterfly Valve Actuator

GC176488W2 C

## Immobilizer Amplifier (Service Code 35)

### Antenna Resistance Inspection

- Remove:
  - Fuel Tank (see Fuel Tank Removal in this chapter)
  - Air Cleaner Housing (see Air Cleaner Housing Removal in this chapter)
- Disconnect:
  - Antenna Lead Connector [A]
- Measure the resistance of the antenna coil in the ignition switch as follows.

#### Antenna Resistance

##### Connections to Antenna

Meter (+) → R Lead

Meter (-) → R Lead

**Standard: About 0.6 ~ 0.9 Ω**

- ★ If the resistance is out of the standard range, replace the ignition switch.

### Amplifier Input Voltage Inspection

#### NOTE

○ Be sure the battery is fully charged.

- Turn the ignition switch OFF.
- Remove:
  - Right Center Fairing (see Center Fairing Removal in the Frame chapter)
- Connect a digital voltmeter to the connectors, using the needle adapter set.

**Special Tool - Needle Adapter Set: 57001-1457**

#### Amplifier Input Voltage

##### Connections to Connectors

Meter (+) → BR/W Lead in Meter Lead Connector [A]

Meter (-) → BK/Y Lead in Amplifier Lead Connector [B]

- Measure the input voltage DC with the connectors joined.
- Turn the ignition switch ON.

#### Input Voltage

**Standard: Battery Voltage (12.8 V or more)**

- Turn the ignition switch OFF.
- ★ If the reading is out of the range, check the wiring (see wiring diagram in this section).
- ★ If the reading and antenna resistance are good, replace the amplifier (see Immobilizer System Parts Replacement in the Electrical System chapter).

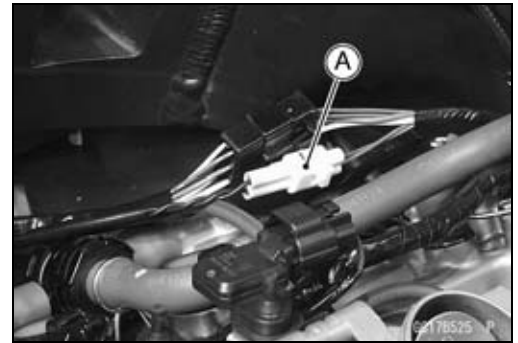

## 3-76 FUEL SYSTEM (DFI)

### Blank Key Detection (Service Code 36)

---

This code appears in the following conditions.

- The transponder [A] in the master and/or user key is malfunction.
- When the spare key of unregistration is used.
- When the master key is registered in the registered ECU. Therefore, the service code 36 will disappear when the above issue is solved.



#### *User Key Inspection*

- Register the user key correctly (see Key Registration in the Electrical System chapter).
- ★ If the service code 36 appears again, the transponder in the key is malfunction, replace it.

Blank Key Detection (Service Code 36)

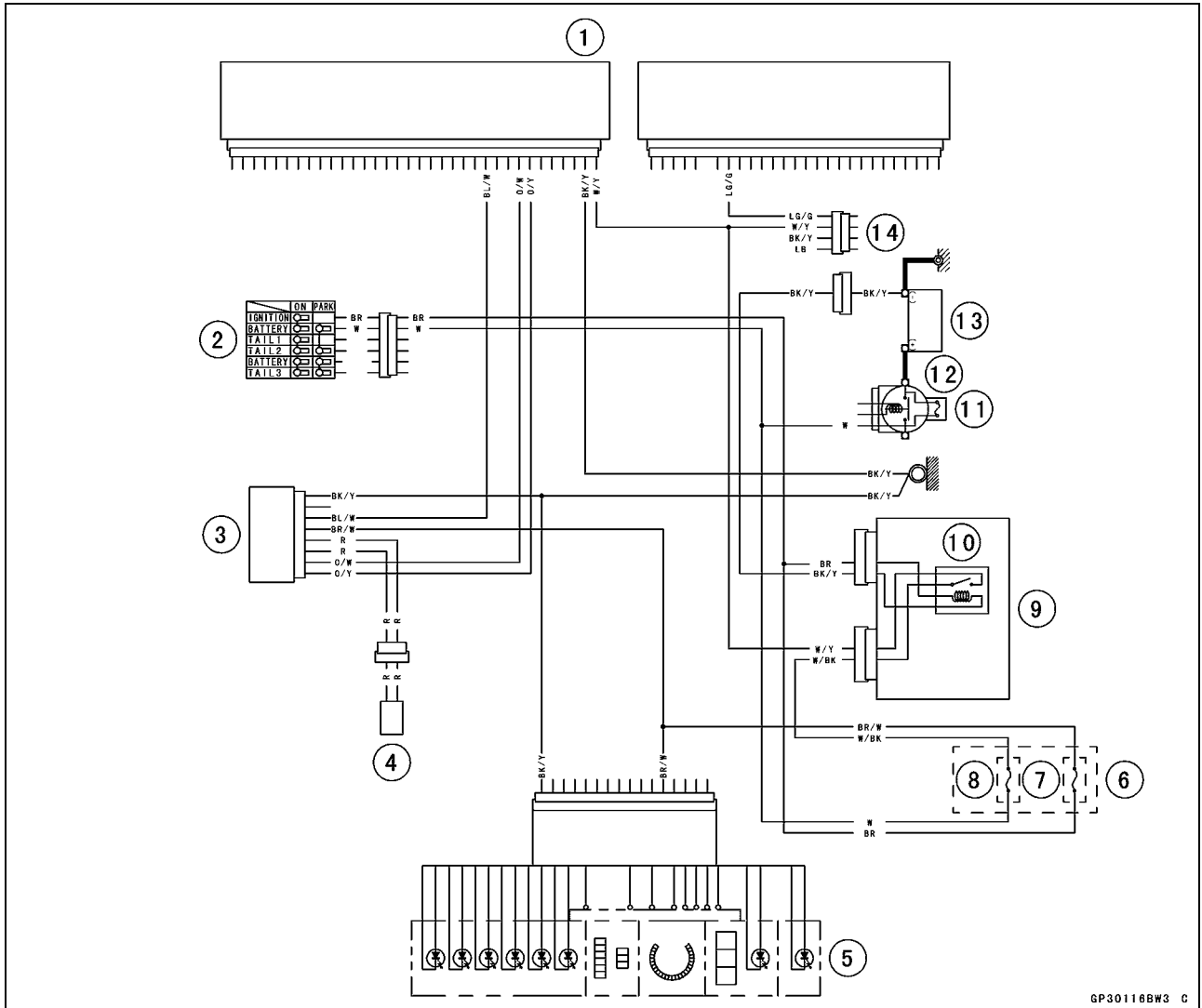

GP30116BW3 C

1. ECU
2. Ignition Switch
3. Immobilizer Amplifier
4. Immobilizer Antenna
5. Meter Unit
6. Fuse Box
7. Ignition Fuse 10 A
8. ECU Fuse 15 A
9. Relay Box
10. ECU Main Relay
11. Starter Relay
12. Main Fuse 30 A
13. Battery 12 V 8 Ah
14. Immobilizer/Kawasaki Diagnostic System Connector

## 3-78 FUEL SYSTEM (DFI)

### Stick Coils #1, #2, #3, #4: (Service Code 51, 52, 53, 54)

- Stick Coil #1: Service Code 51
- Stick Coil #2: Service Code 52
- Stick Coil #3: Service Code 53
- Stick Coil #4: Service Code 54

#### Removal/Installation

#### CAUTION

**Never drop the stick coils, especially on a hard surface. Such a shock to the stick coil can damage it.**

- See the Stick Coil (Ignition Coil together with Spark Plug Cap) Removal/Installation in the Electrical System chapter.

#### Input Voltage Inspection

#### NOTE

○ Be sure the battery is fully charged.

- Turn the ignition switch OFF.
- Remove the ECU (see ECU Removal in this chapter). Do not disconnect the ECU connector.
- Connect a digital voltmeter [A] as shown, with the needle adapter set.
- Measure the input voltage to each primary winding of the ignition coils with the engine stopped, and with the connectors joined.
- Turn the ignition switch ON.

#### Stick Coil Input Voltage at ECU

##### Connections for Stick Coil #1

- Meter (+) → BK lead (terminal 47)
- Meter (-) → BK/Y lead (terminal 59)

##### Connections for Stick Coil #2

- Meter (+) → BK/G lead (terminal 46)
- Meter (-) → BK/Y lead (terminal 59)

##### Connections for Stick Coil #3

- Meter (+) → BK/W lead (terminal 45)
- Meter (-) → BK/Y lead (terminal 59)

##### Connections for Stick Coil #4

- Meter (+) → BK/O lead (terminal 60)
- Meter (-) → BK/Y lead (terminal 59)

#### Input Voltage at ECU

**Standard: Battery Voltage (12.8 V or more)**

- ★ If the reading is out of the standard, check the wiring (see wiring diagram in this section).
- ★ If the reading is good, the input voltage is normal. Crank the engine, and check the peak voltage of the stick coils (see Stick Coil Primary Peak Voltage Inspection in the Electrical System chapter) in order to check the primary coils.

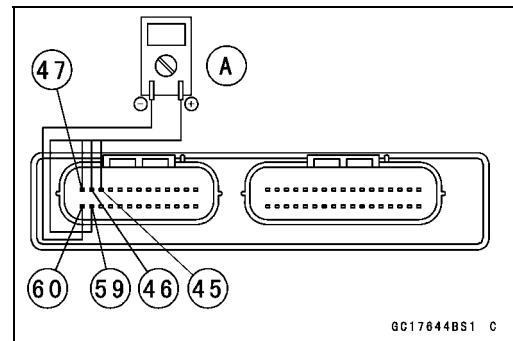

Stick Coils #1, #2, #3, #4: (Service Code 51, 52, 53, 54)

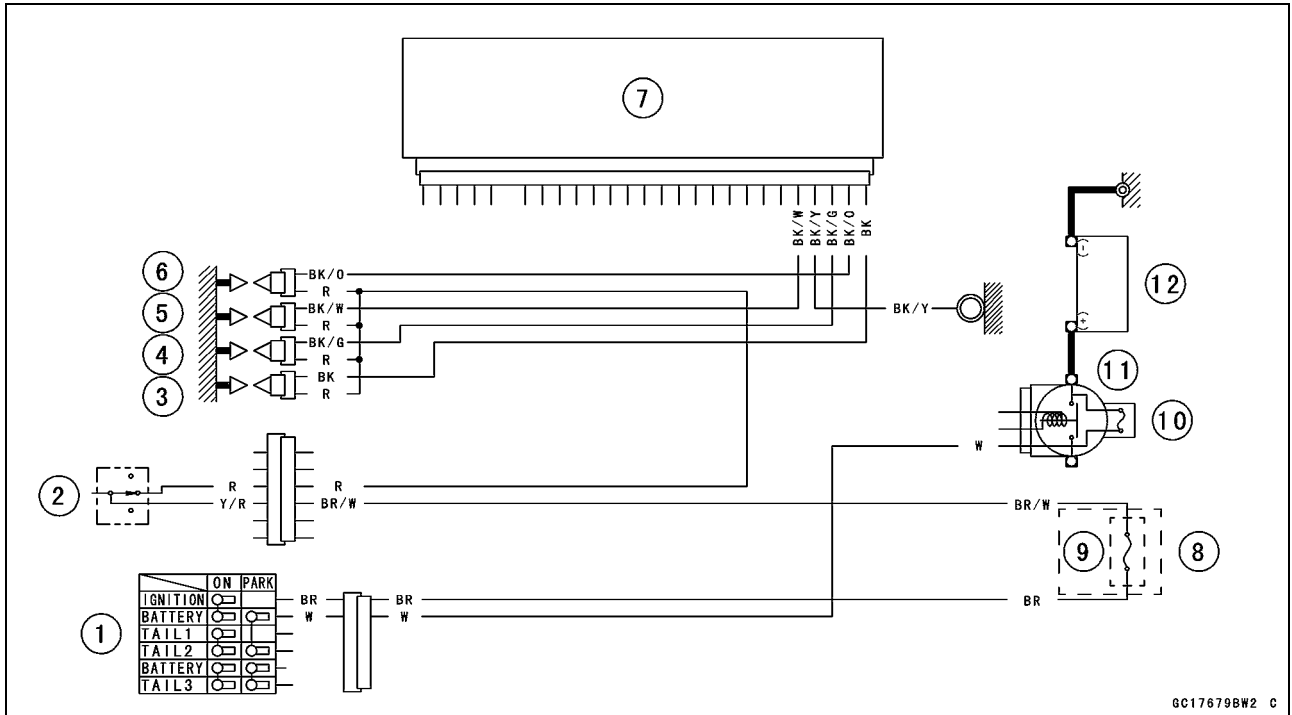

GC17679BW2 C

1. Ignition Switch
2. Engine Stop Switch
3. Stick Coil #1
4. Stick Coil #2
5. Stick Coil #3
6. Stick Coil #4
7. ECU
8. Fuse Box
9. Ignition Fuse 10 A
10. Starter Relay
11. Main Fuse 30 A
12. Battery 12 V 8 Ah

## 3-80 FUEL SYSTEM (DFI)

### Subthrottle Valve Actuator (Service Code 62)

#### Subthrottle Valve Actuator Removal

#### CAUTION

Do not remove the subthrottle valve actuator [A] since it has been adjusted and set with precision at the factory.

Never drop the throttle body assy, especially on a hard surface. Such a shock to the actuator can damage it.

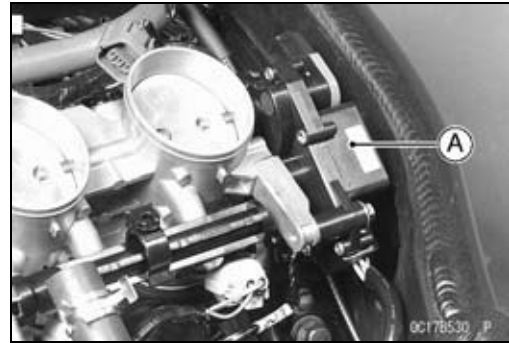

#### Subthrottle Valve Actuator Inspection

- Remove the air cleaner housing (see Air Cleaner Housing Removal in this chapter).
- Turn the ignition switch ON.
- Check to see that all subthrottle valves [A] open and close smoothly.
- ★ If the subthrottle valves do not operate, check the actuator internal resistance (see Resistance Inspection in this chapter).

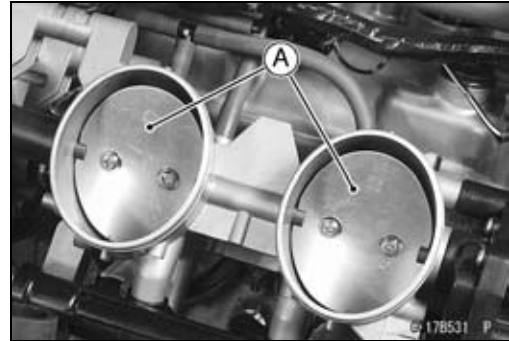

#### Resistance Inspection

- Turn the ignition switch OFF.
- Remove the subthrottle valve actuator connector.
- Connect a digital meter to the connector [A].
- Measure the subthrottle valve actuator resistance.

#### Subthrottle Valve Actuator Resistance

Connections: BK lead [1] ↔ P lead [2]

G lead [3] ↔ W/BL lead [4]

Standard: About 5 ~ 7 Ω

- ★ If the reading is out of the range, replace the throttle body assy (see Throttle Body Assy Removal/Installation in this chapter).
- ★ If the reading is within the range, check the input voltage (see Input Voltage Inspection in this section).

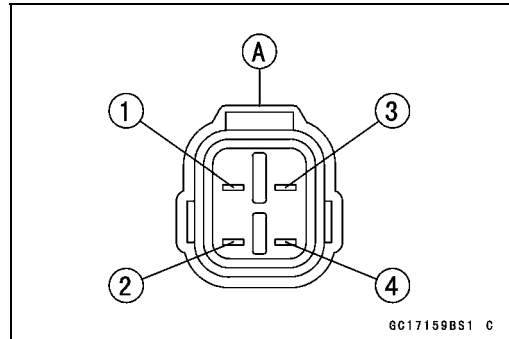

**Subthrottle Valve Actuator (Service Code 62)**

*Input Voltage Inspection*

**NOTE**

○Be sure the battery is fully charged.

- Turn the ignition switch OFF.
- Connect the peak voltage adapter [A] and a digital meter [B] to the connector [C], using the needle adapter set [D].

**Special Tools - Peak Voltage Adapter: 57001-1415**  
**Type: KEK-54-9-B**  
**Needle Adapter Set: 57001-1457**

**Subthrottle Valve Actuator Input Voltage Connections to Harness Connector**

(I) Meter (+) → BK/BL lead [1]

Meter (-) → P/BK lead [2]

(II) Meter (+) → G lead [3]

Meter (-) → W/BL lead [4]

- Measure the actuator input voltage with the engine stopped, and with the connector joined.
- Turn the ignition switch ON.

**Input Voltage at Sensor**

**Standard: About DC 8.5 ~ 10.5 V**

- ★ If the reading is out of the range, check the wiring to ECU (see wiring diagram in this section).
- ★ If the wiring is good, replace the ECU (see ECU Removal in this chapter).

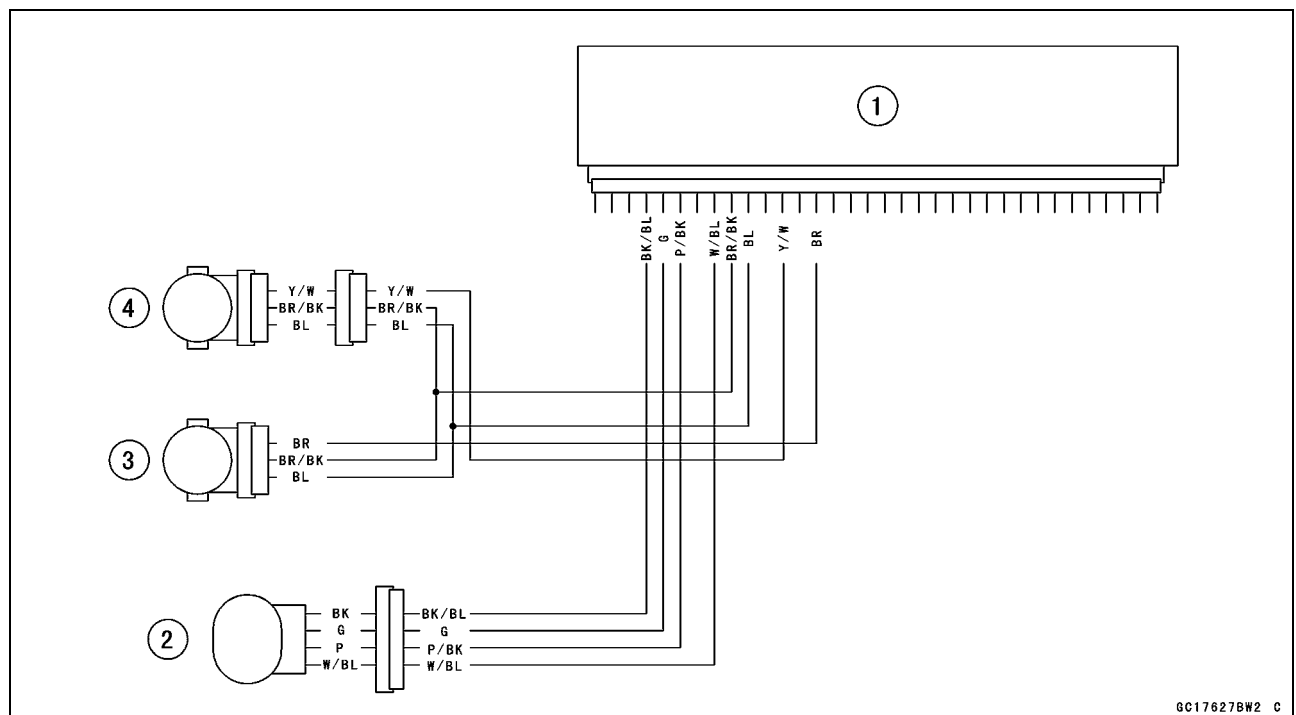
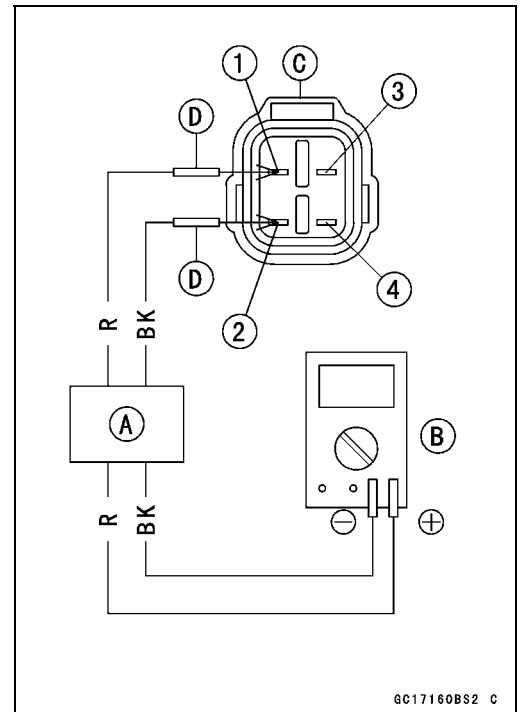

1. ECU
2. Subthrottle Valve Actuator
3. Subthrottle Sensor
4. Main Throttle Sensor

## 3-82 FUEL SYSTEM (DFI)

### Exhaust Butterfly Valve Actuator (Service Code 63)

#### Exhaust Butterfly Valve Actuator Removal

- Remove:
  - Seat Cover (see Seat Cover Removal in the Frame chapter)
- Put off the rubber boots of exhaust butterfly valve cables.
- Loosen the locknuts [A] and adjuster nut [B].
- Remove the guard bracket [C] (Refer to the Immobilizer System Parts Replacement in the Electrical System chapter for Europe Model).
- Remove:
  - Clamp [A]
  - Exhaust Butterfly Valve Cables [B]
  - Connectors [C]
- Remove the bolts [D] and exhaust butterfly valve actuator [E].
- Remove:
  - Exhaust Butterfly Valve Actuator Pulley [A].
- Hold the pulley with a suitable tool.

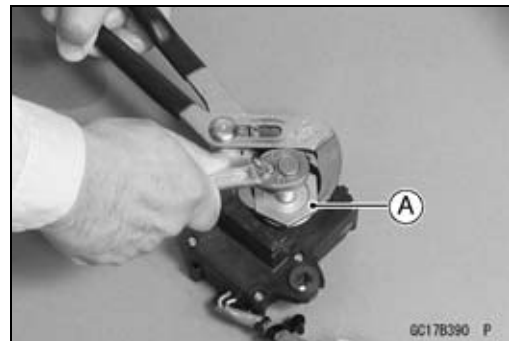
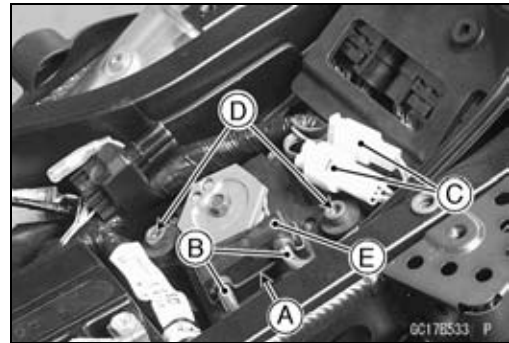
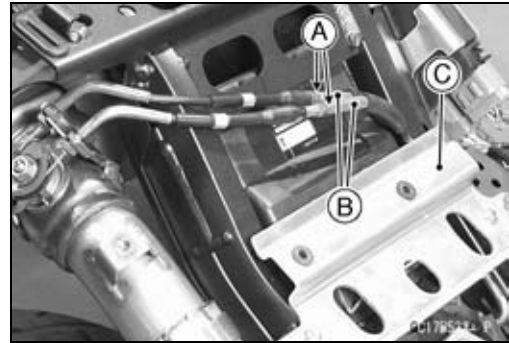

#### CAUTION

If the pulley bolt is removed without holding, the actuator damage will occur.

#### Exhaust Butterfly Valve Actuator Installation

- Install the pulley [A] on the actuator.
  - Hold the pulley with a suitable tool [B] and tighten the bolt.
- Torque - Exhaust Butterfly Valve Actuator Pulley Bolt: 4.9 N·m (0.50 kgf·m, 43 in·lb)**

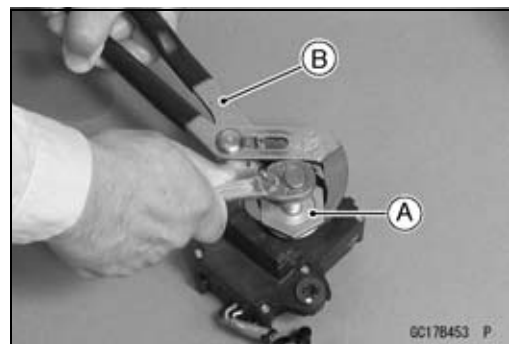

#### CAUTION

If the pulley bolt is tightened without holding, the actuator damage will occur.

- Confirm the pulley angle [A] ( $41.7^\circ \pm 7^\circ$ ) as shown. It is original position of the pulley.
- ★ If the angle is not within the specified angle, adjust the actuator as follows.
  - Connect the actuator connectors.
  - Turn the ignition switch ON.
  - Confirm the pulley turns clockwise and then counterclockwise, and clockwise again.
  - Turn the ignition switch OFF.
  - Confirm the pulley turns counterclockwise little.
  - The position is original position of the pulley.
- ★ If the position is not within the specified angle above, replace the exhaust butterfly valve actuator.

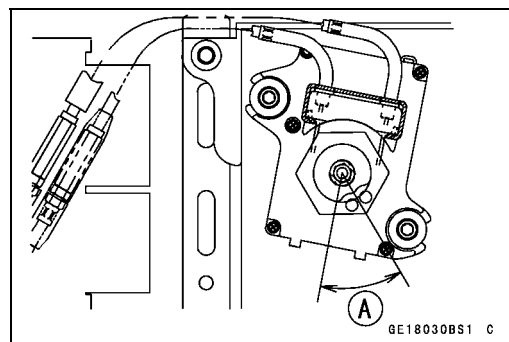

**Exhaust Butterfly Valve Actuator (Service Code 63)**

- Install the actuator [A] on the frame.
  - Collars [B]
  - Washers [C]
  - Exhaust Butterfly Valve Actuator Mounting Bolts [D]
- Tighten:
  - Torque - Exhaust Butterfly Valve Actuator Mounting Bolts:**  
**6.9 N·m (0.70 kgf·m, 61 in·lb)**
- Install the open cable first and then close cable (see Exhaust Butterfly Valve Cable Installation in the Engine Top End chapter).

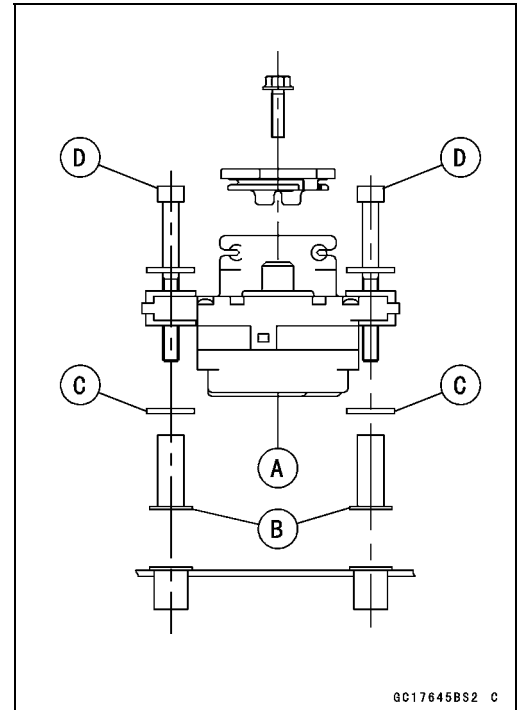

**Exhaust Butterfly Valve Actuator Inspection**

- Remove:
  - Front Seat (see Front Seat Removal in the Frame chapter)
- Turn the ignition switch ON.
- Check to see the pulley [A] clockwise [B] and counter-clockwise [C] smoothly.
- ★ If the pulley does not operate, check the exhaust butterfly valve actuator output voltage (see Output Voltage Inspection in this section).

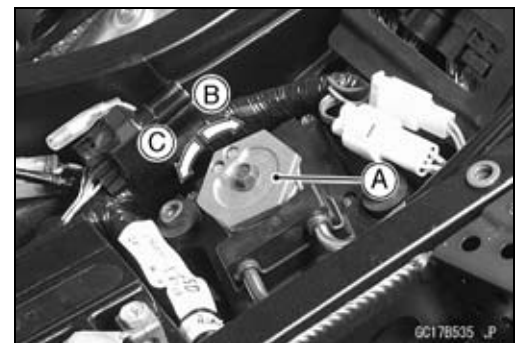

# 3-84 FUEL SYSTEM (DFI)

## Exhaust Butterfly Valve Actuator (Service Code 63)

### Output Voltage Inspection

- Remove:
  - Front Seat (see Front Seat Removal in the Frame chapter)
- Measure the output voltage at the 3 pins connector of the exhaust butterfly valve actuator [A] when the pulley is original position as follows.
- Disconnect:
  - 2 pins Connector [B]
  - 3 pins Connector [C]
- Connect the adapter [D] between the 3 pins connectors and digital voltmeter [E].
  - Main Harness [F]

**Special Tool - Throttle Sensor Setting Adapter #1: 57001-1400**

### Connections

**Meter (+) → BL Lead [G] in Adapter (Y Lead of Actuator)**

**Meter (-) → BK/BL Lead [H] in Adapter (BK Lead of Actuator)**

- Turn the ignition switch ON and wait until the pulley stops.
- Turn the ignition switch OFF and wait until the pulley stops.

### Actuator Output Voltage (Pulley Original Position)

**Standard: 3.46 ~ 3.76 V**

- ★ If the output voltage is out of the standard, remove the actuator and check the original position of pulley (see Exhaust Butterfly Valve Actuator Installation in this chapter).

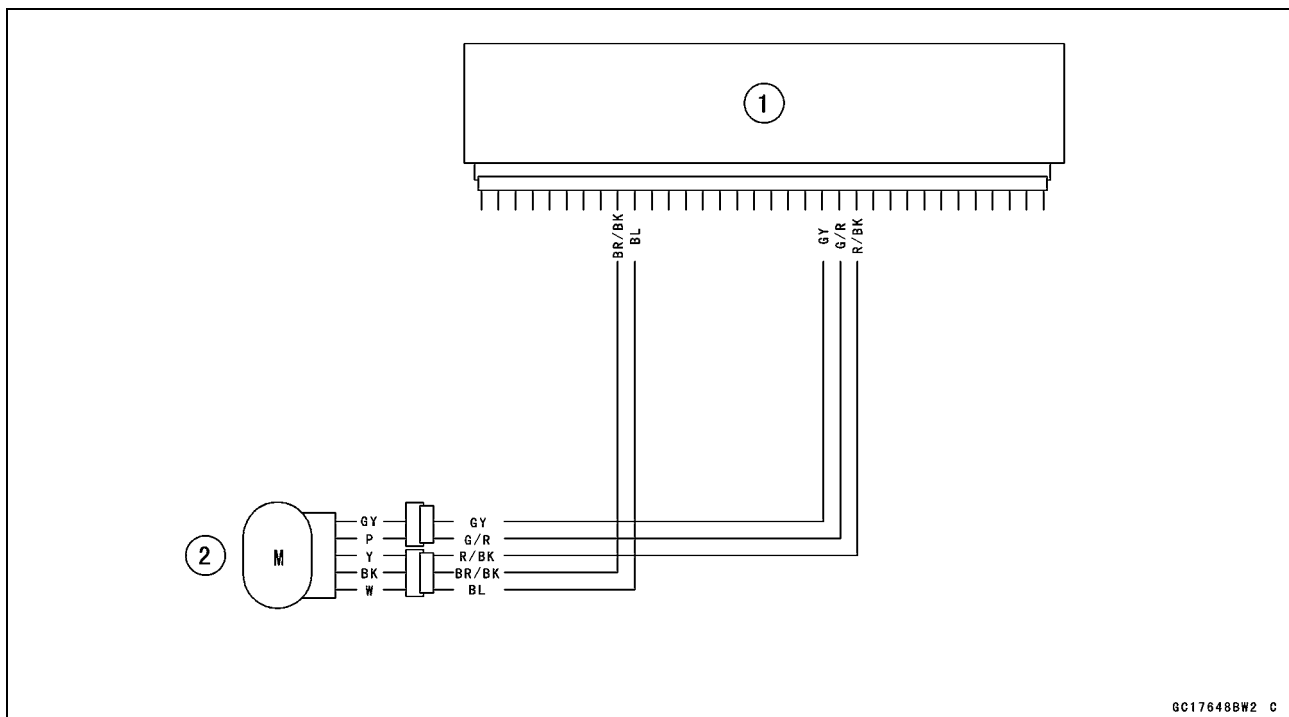
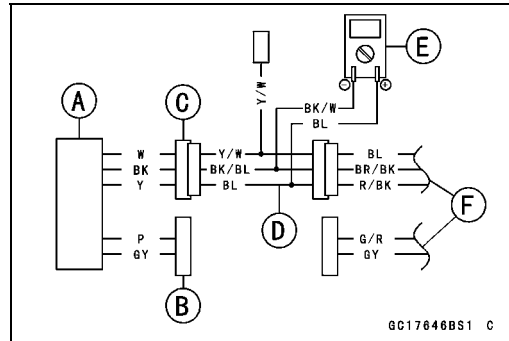
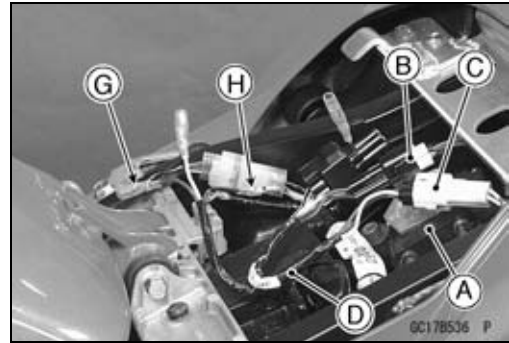

1. ECU
2. Exhaust Butterfly Valve Actuator

**ECU**

**CAUTION**

**Never drop the ECU, especially on a hard surface. Such a shock to the ECU can damage it.**

*ECU Identification*

○Most countries have their own regulations, so each ECU has different characteristic. So, do not confuse ECU with each other and use only the ECU for your model. Otherwise, the motorcycle cannot clear the regulation.

**ECU Identification**

Part Number [A]	Specification
21175-0057	U.S.A., without Immobilizer
	U.S.A. (California), without Immobilizer
	Canada, without Immobilizer
	New Zealand without Immobilizer
21175-0046	Other than U.S.A., U.S.A. (California), Canada and New Zealand, without Immobilizer
21175-0072	Malaysia, with Immobilizer

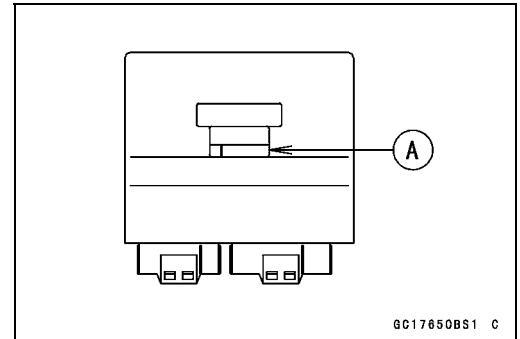

*ECU Removal*

- Remove:
  - Seat Cover (see Seat Cover Removal in the Frame chapter)
  - Seat Bracket [A]

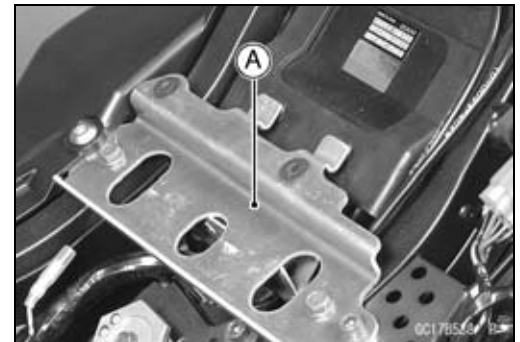

- Lift up the ECU [A] with rubber protector [B].

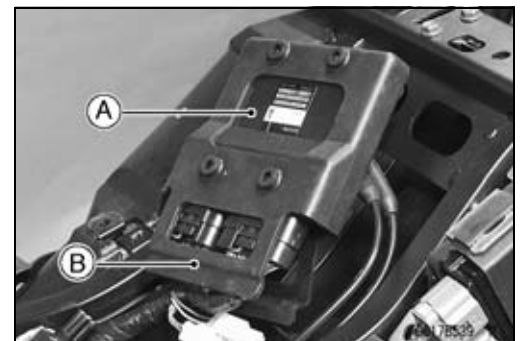

# 3-86 FUEL SYSTEM (DFI)

## ECU

- Remove:
  - ECU Lead Connectors [A]
  - ECU [B]
- Refer to the Immobilizer System Parts Replacement in the Electrical System chapter for Europe model.

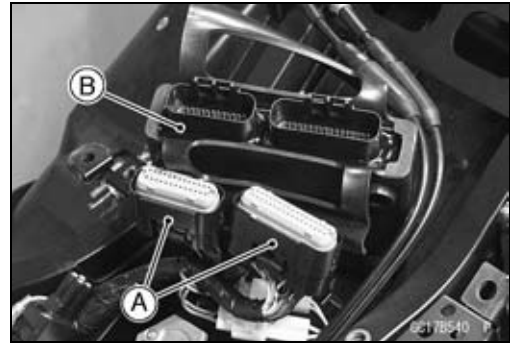

### ECU Installation

- Install:
  - ECU [A] (In rubber protector [B])
  - ECU Lead Connectors

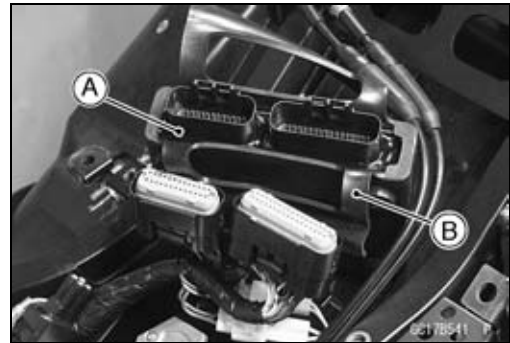

### ECU Power Supply Inspection

- Visually inspect the terminals [A] of the ECU connectors.
- ★ If the connector is clogged with mud or dust, blow it off with compressed air.
- ★ Replace the main harness if the terminals of the main harness connectors are cracked, bent, or otherwise damaged.
- ★ Replace the ECU if the terminals of the ECU connectors are cracked, bent, or otherwise damaged (see ECU Removal/Installation in this chapter).



- With the ECU connectors connected, check the following ground lead for continuity with the ignition switch OFF, using a tester and needle adapter set.

**Special Tool - Needle Adapter Set: 57001-1457**

### ECU Grounding Inspection

**34, 58, or 59 Terminal (BK/Y) ↔ Battery (-) Terminal: 0 Ω**

**Engine Ground ↔ Battery (-) Terminal: 0 Ω**

- ★ If no continuity, check the connector, the engine ground lead, or main harness, and repair or replace them if necessary.

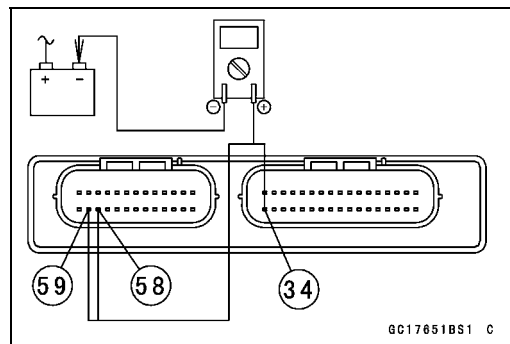

## ECU

- Check the ECU power source voltage with a tester [A].
- Position the terminal in accordance with terminal numbers of ECU connectors in this chapter figure.

Battery [B]

### ECU Power Source Inspection

#### Tester Connections:

- between 16 (W/Y) Terminal and Battery (-) Terminal
- between 17 (W/BK) Terminal and Battery (-) Terminal

#### Ignition Switch OFF:

- 16 (W/Y) Terminal 0 V,
- 17 (W/BK) Terminal Battery Voltage (12.8 V or more)

#### Ignition Switch ON:

- Battery Voltage (12.8 V or more)

- ★ If the tester does not read as specified, check the following:

- Power Source Wiring (see wiring diagram in this section)
- Main Fuse 30 A (see Fuse Inspection in the Electrical System chapter)
- ECU Fuse 15 A (see ECU Fuse Inspection in this chapter)
- ECU Main Relay (see ECU Main Relay Inspection in this chapter)

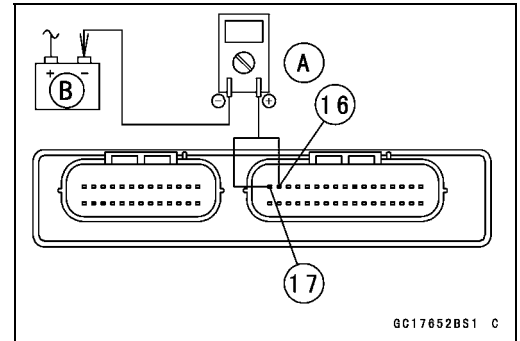

### ECU Power Source Circuit

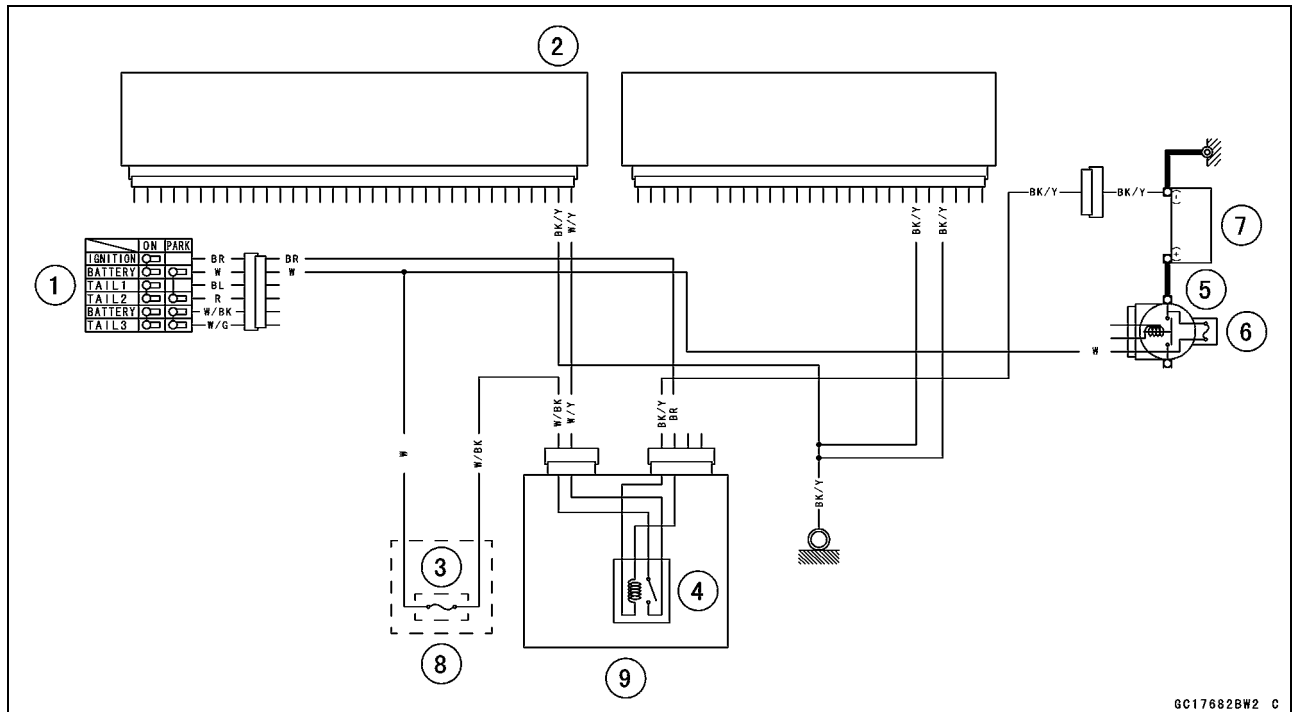

1. Ignition Switch
2. ECU
3. ECU Fuse 15 A
4. ECU Main Relay
5. Main Fuse 30 A
6. Starter Relay
7. Battery, 12 V 8 Ah
8. Fuse Box
9. Relay Box

## 3-88 FUEL SYSTEM (DFI)

---

### DFI Power Source

---

#### *ECU Fuse Removal*

- Refer to the Electrical System chapter for the ECU Fuse Removal.

#### *ECU Fuse Installation*

- ★ If a fuse fails during operation, inspect the DFI system to determine the cause, and then replace it with a new fuse of proper amperage.
- Refer to the Electrical System chapter for the ECU Fuse Installation.

#### *ECU Fuse Inspection*

- Refer to the Electrical System chapter for the ECU Fuse Inspection.

**FI Indicator Light (LED)**

*Light (LED) Inspection*

- Remove the meter unit (see Meter Unit Removal in the Electrical System chapter).
- Using two auxiliary leads, supply battery power to the FI indicator light (LED) [A].  
12 V Battery [B]

**FI Indicator Light (LED) Check**

**Connector:** Meter Connector [C] (disconnected)

**Connection:** BR/W Lead Terminal [1] of the Meter  
→ Battery (+) Terminal

BR/R Lead Terminal [6] of the Meter  
→ Battery (-) Terminal

**Criterion:** The light (LED) should light.

★ If the light (LED) does not go on, replace the meter unit.

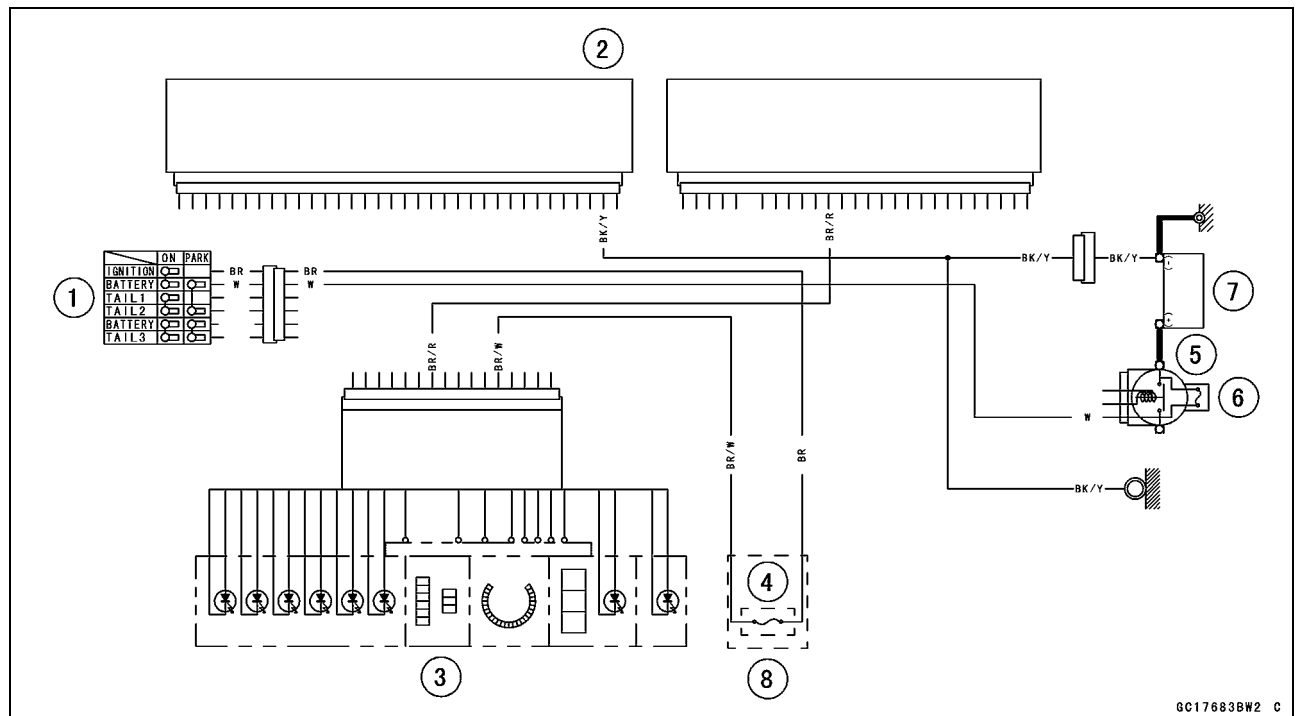
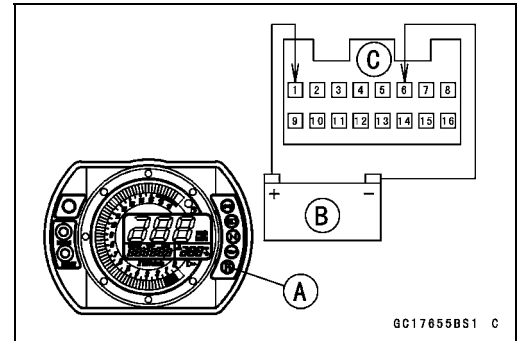

1. Ignition Switch
2. ECU
3. FI Indicator Light (LED)
4. Ignition Fuse 10 A
5. Main Fuse 30 A
6. Starter Relay
7. Battery, 12 V 8 Ah
8. Fuse Box

## 3-90 FUEL SYSTEM (DFI)

### Fuel Line

#### Fuel Pressure Inspection

#### NOTE

○Be sure the battery is fully charged.

- Remove:
  - Front Seat (see Front Seat Removal in the Frame chapter)
  - Fuel Tank Bolts (see Fuel Tank Removal in this chapter)
- Be sure to place a piece of cloth around the fuel supply pipe of the throttle body assembly and fuel pump.
- Remove the fuel hose (see Fuel Tank Removal in this chapter).

#### ⚠ WARNING

**Be prepared for fuel spillage; any spilled fuel must be completely wiped up immediately. When the fuel hose is disconnected, fuel spills out from the hose and the pipe because of residual pressure. Cover the hose connection with a piece of clean cloth to prevent fuel spillage.**

- Install the fuel pressure gauge adapter [A] and fuel hoses (Special Tool: 57001-1607) [B] between the fuel supply pipes of the fuel pump and throttle body assy.
- Connect the pressure gauge [C] to the fuel pressure gauge adapter.

**Special Tools - Oil Pressure Gauge, 5 kgf/cm<sup>2</sup>: 57001-125  
Fuel Pressure Gauge Adapter: 57001-1593  
Fuel Hose: 57001-1607**

#### ⚠ WARNING

**Do not try to start the engine with the fuel hoses disconnected.**

- Turn the ignition switch ON. The fuel pump will turn for 3 seconds, and then stop.

#### CAUTION

**Do not drive the fuel pump 3 seconds or more without the fuel in the fuel tank. If the fuel pump is driven without the fuel, it may be damaged.**

- Measure the fuel pressure with the engine stopped.

#### Fuel Pressure

right after Ignition Switch ON, with pump running:

Standard: 304 kPa (3.1 kgf/cm<sup>2</sup>, 44 psi)

after 3 seconds from Ignition Switch ON, with pump stopped:

Standard: 280 kPa (2.9 kgf/cm<sup>2</sup>, 41 psi) , residual fuel pressure

The system should hold the residual pressure about 30 seconds.

- Start the engine, and let it idle.
- Measure the fuel pressure with the engine idling.

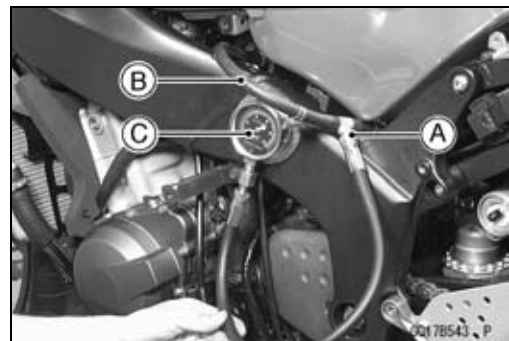

## Fuel Line

### Fuel Pressure (Idling)

Standard: 304 kPa (3.1 kgf/cm<sup>2</sup>, 44 psi)

#### NOTE

○ *The gauge hand will fluctuate. Read the pressure at the average of the maximum and minimum indications.*

- ★ If the fuel pressure is much higher than the specified, replace the fuel pump (see Fuel Pump Removal/Installation in this chapter).
- ★ If the fuel pressure is much lower than specified, check the following:
  - Fuel Line Leakage
  - Amount of Fuel Flow (see Fuel Flow Rate Inspection in this chapter)
- ★ If the fuel pressure is much lower than specified, and if inspection above checks out good, replace the throttle body assy, nozzle assy or the fuel pump and measure the fuel pressure again (see appropriate sections).
- Remove the fuel pressure gauge, fuel hoses and adapter.
- Install the fuel tank (see Fuel Tank Installation in this chapter).

### Fuel Flow Rate Inspection

#### NOTE

○ *Be sure the battery is fully charged.*

#### **⚠ WARNING**

**Gasoline is extremely flammable and can be explosive under certain conditions. Make sure the area is well-ventilated and free from any source of flame or sparks; this includes any appliance with a pilot light. Do not smoke. Turn the ignition switch OFF. Be prepared for fuel spillage; any spilled fuel must be completely wiped up immediately.**

- Turn the ignition switch, and engine stop switch OFF.
- Wait until the engine cools down.
- Prepare a fuel hose of the inside diameter 7.5 mm (0.30 in.) and a measuring cylinder.
- Remove:
  - Front Seat (see Front Seat Removal in the Frame chapter)
  - Fuel Tank Bolts (see Fuel Tank Removal in this chapter)

## 3-92 FUEL SYSTEM (DFI)

### Fuel Line

- Open the fuel tank cap [A] to lower the pressure in the tank.
- Be sure to place a piece of cloth around the fuel supply pipe of the fuel pump.
- Remove the fuel hose from the fuel supply pipe of the fuel pump (see Fuel Tank Removal in this chapter).

#### **⚠ WARNING**

**Be prepared for fuel spillage; any spilled fuel must be completely wiped up immediately. When the fuel hose is disconnected, fuel spills out from the hose and the pipe because of residual pressure. Cover the hose connection with a piece of clean cloth to prevent fuel spillage.**

- Connect the prepared fuel hose [A] to the fuel supply pipe of the fuel pump.
- Secure the fuel hose with a clamp.
- Insert the fuel hose into the measuring cylinder [B].

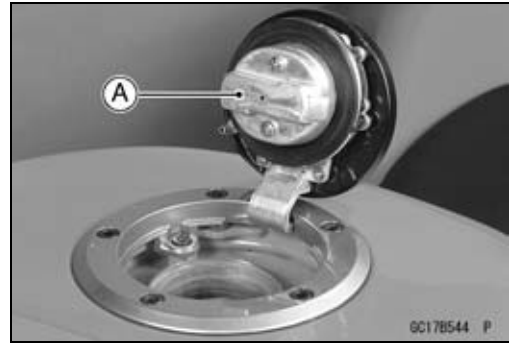

#### **⚠ WARNING**

**Wipe off spilled out fuel immediately. Be sure to hold the measuring cylinder vertical.**

- Close the fuel tank cap.
- With the engine stopped, turn the ignition switch ON. The fuel pump should operate for 3 seconds, and then should stop.

#### **CAUTION**

**Do not drive the fuel pump 3 seconds or more without the fuel in the fuel tank. If the fuel pump is driven without the fuel, it may be damaged.**

- Measure the discharge for 3 seconds.
- Repeat this operation several times.

#### **Amount of Fuel Flow**

**Standard: 67 mL (2.27 US oz) or more for 3 seconds**

- ★ If the fuel flow is much less than the specified, check the following:
  - Battery Condition (see Charging Condition Inspection in the Electrical System chapter)
- After inspection, connect the fuel hoses (see Fuel Tank Installation in this chapter).
- Start the engine and check for fuel leakage.

## Fuel Pump

### Fuel Pump Removal

#### CAUTION

Never drop the fuel pump, especially on a hard surface. Such a shock to the pump can damage it.

#### ⚠ WARNING

Gasoline is extremely flammable and can be explosive under certain conditions. Make sure the area is well-ventilated and free from any source of flame or sparks; this includes any appliance with a pilot light. Do not smoke. Turn the ignition switch OFF. Disconnect the battery (-) terminal.

To make fuel spillage minimum, draw the fuel out from the fuel tank when the engine is cold. Be prepared for fuel spillage; any spilled fuel must be completely wiped up immediately.

- Draw the fuel out from the fuel tank with a commercially available electric pump.
- Remove the fuel tank (see Fuel Tank Removal in this chapter).
- Be careful of fuel spillage from the fuel tank since fuel still remains in the fuel tank and fuel pump. Plug the fuel pipe of the fuel tank.
- Turn the fuel tank upside down.
- Unscrew the fuel pump bolts [A], and take out the fuel pump assembly [B] and gasket.
- Discard the fuel pump gasket.

#### CAUTION

Do not pull the leads [C] of the fuel pump and fuel reserve switch. If they are pulled, the lead terminals may be damaged.

### Fuel Pump Installation

- Remove dirt or dust from the fuel pump [A] by lightly applying compressed air.
- Replace the fuel pump gasket with a new one.

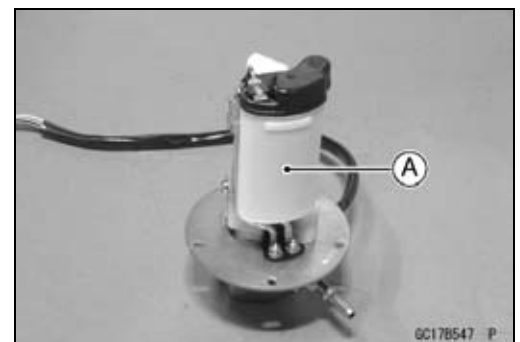
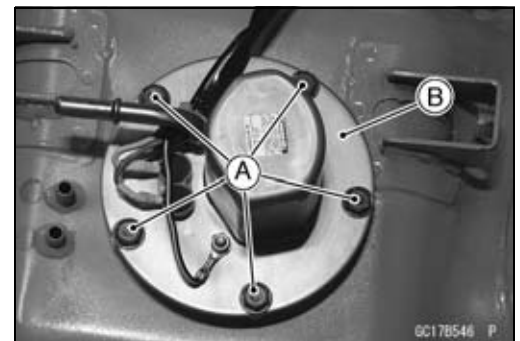

## 3-94 FUEL SYSTEM (DFI)

### Fuel Pump

- Check that the fuel pump terminals [A], fuel reserve switch terminal [B] and band [C] are in place.  
Front [D]
- Apply a non-permanent locking agent to the threads of the fuel pump bolts.
- Tighten the fuel pump bolts to a snug fit following the tightening sequence shown.
- Following the tightening sequence, tighten the fuel pump bolts to the specified torque.

**Torque - Fuel Pump Bolts: 9.8 N·m (1.0 kgf·m, 87 in·lb)**

- Tighten the fuel pump bolts again to check the tightness in the order shown.

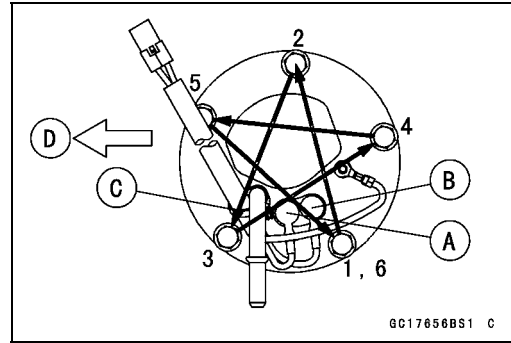

#### Operation Inspection

##### NOTE

○Be sure the battery is fully charged.

- Turn the ignition switch ON and make sure that the fuel pump operates (make light sounds) for 3 seconds, and then stops.
- Turn the ignition switch OFF.
- ★If the pump does not work as described above, inspect the operating voltage.

#### Operating Voltage Inspection

##### NOTE

○Be sure the battery is fully charged.

- Turn the ignition switch OFF.
- Connect the hand tester (25 V DC) to the connector [A], with needle adapter set.

**Special Tools - Hand Tester: 57001-1394**

**Needle Adapter Set: 57001-1457**

- Measure the operating voltage with the engine stopped, and with the connector joined.
- Turn the ignition switch ON.
- The tester needle should indicate battery voltage for 3 seconds, and then 0 V.

#### Pump Operating Voltage at Pump

##### Connections to Pump Connectors

Tester (+) → Y/R Lead

Tester (-) → BK/W Lead

#### Operating Voltage at Pump Connector

**Standard: Battery Voltage (12.8 V) for 3 seconds, and then 0 V**

- ★If the reading stays on battery voltage, and never shows 0 V. Check the ECU and fuel pump relay.
- ★If the voltage is in specification, but the pump doesn't work, replace the pump (see Fuel Pump Removal/Installation in this chapter).
- ★If there is still no battery voltage, check the pump relay (see Fuel Pump Relay Inspection in this chapter).

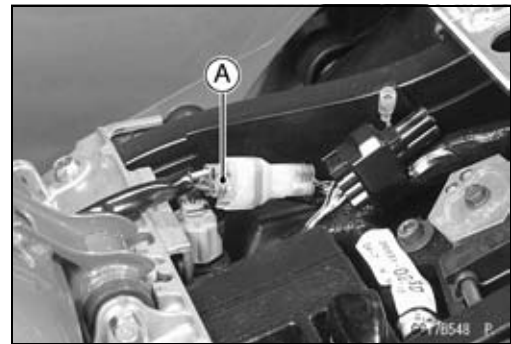

Fuel Pump

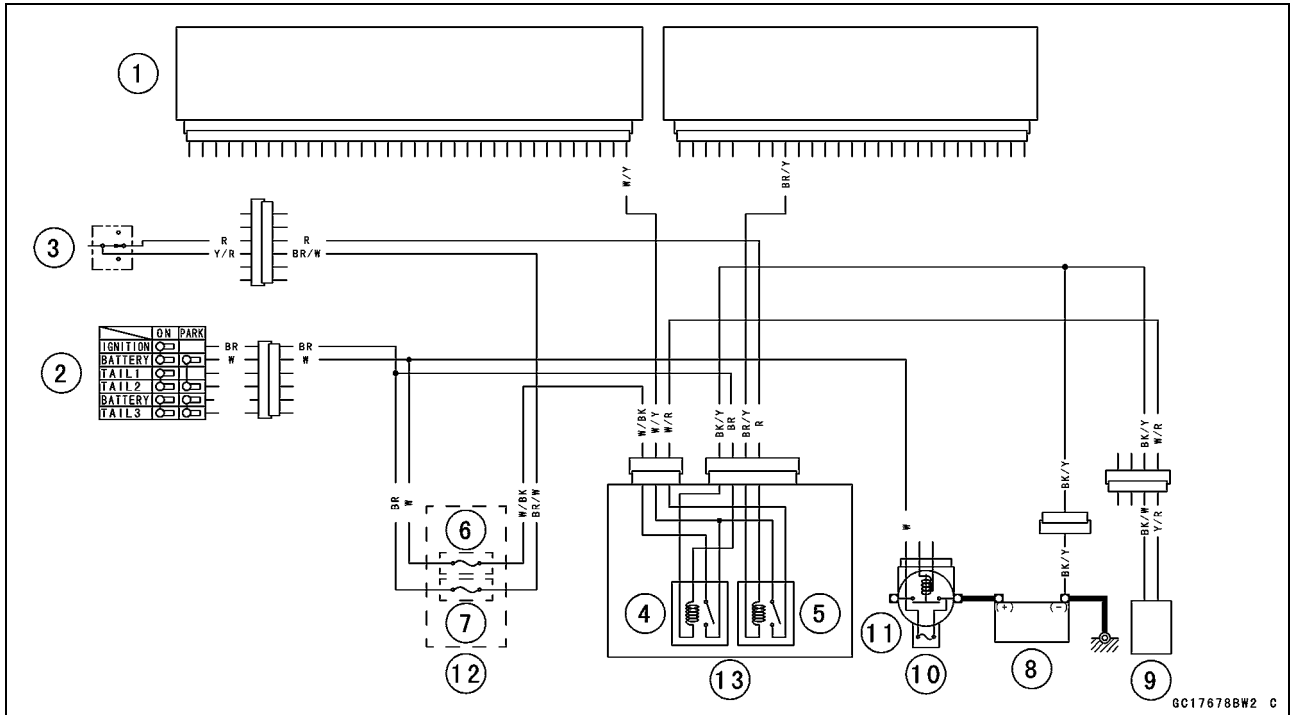

1. ECU
2. Ignition Switch
3. Engine Stop Switch
4. ECU Main Relay
5. Fuel Pump Relay
6. ECU Fuse 15 A
7. Ignition Fuse 10 A
8. Battery 12 V 8 Ah
9. Fuel Pump
10. Starter Relay
11. Main Fuse 30 A
12. Fuse Box
13. Relay Box

GC17678BW2 C

# 3-96 FUEL SYSTEM (DFI)

## Fuel Injectors

### CAUTION

Never drop the injector, especially on a hard surface. Such a shock to the injector can damage it.

### Audible Inspection

#### Primary Fuel Injector

- Start the engine.
- Apply the tip of a screwdriver [A] to the injector [B]. Put the grip end onto your ear, and listen whether the injector is clicking or not.
- A sound scope can also be used.
- Do the same for the other injector.
- ★ If all the injectors click at a regular intervals, the injectors are good.
- The click interval becomes shorter as the engine speed rises.
- ★ If either injector doesn't click, perform the "Injector Signal Test" for injector operation.

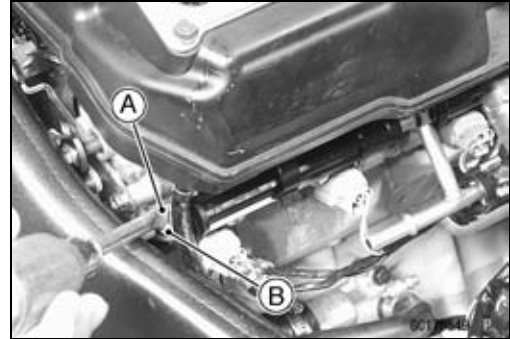

#### Secondary Fuel Injector

- The secondary fuel injectors inspection is as same as for the primary fuel injectors.
  - Tip of a screw driver [A]
  - Secondary Fuel Injector [B]

### NOTE

○ The secondary fuel injectors operating with following conditions.

- Engine speed is over 5 500 rpm (r/min)
- Throttle opening is over 30°

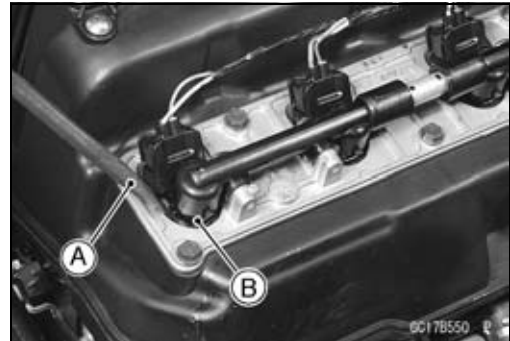

### Injector Signal Test

- Prepare two test light sets with male terminals as shown.
  - Rating of Bulb [A]: 12 V × 3 ~ 3.4 W
  - Terminal Width [B]: 1.8 mm (0.07 in.)
  - Terminal Thickness [C]: 0.8 mm (0.03 in.)

### CAUTION

Do not use larger terminals than specified above. A larger terminal could damage the injector main harness connector (female), leading to harness repair or replacement.

Be sure to connect bulbs in series. The bulb works as a current limiter to protect the solenoid in the injector from excessive current.

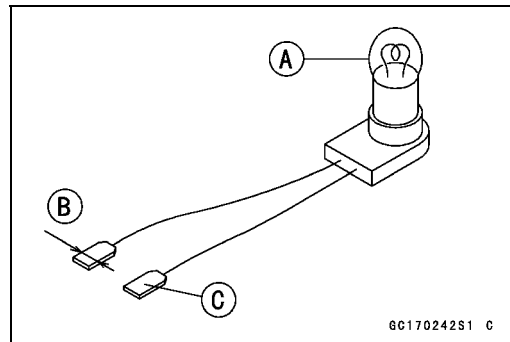

## Fuel Injectors

- Remove connectors for injector [A].
- Connect each test light set [B] to the injector sub harness connector [C].
- Turn the ignition switch ON.
- While cranking the engine with the starter motor, watch the test lights.
- ★ If the test lights flicker at regular intervals, the injector circuit in the ECU, and the wiring are good. Perform the "Injector Resistance Inspection" in this chapter.

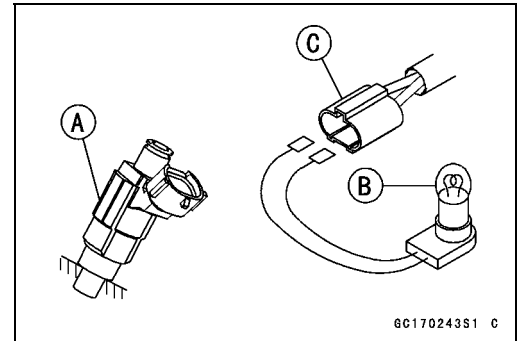

○ Injector signals can be also confirmed by connecting the hand tester (AC 10 V) instead of the test light set to the injector main harness (female) connector. Crank the engine with the starter motor, and check to see if the hand oscillates at regular intervals.

**Special Tool - Hand Tester: 57001-1394**

- ★ If the test light doesn't flicker (or the test hand doesn't oscillates), check the wiring and connectors again. If the wiring is good, check the injector voltage (see Injector Voltage Inspection in this chapter).

### Injector Resistance Inspection

#### Primary Fuel Injector

- Remove the fuel tank (see Fuel Tank Removal in this chapter).
- Disconnect the connector from the injector [A] (see Throttle Body Assy Disassembly/Assembly in this chapter).
- Measure the injector resistance with the hand tester [B].

**Special Tool - Hand Tester: 57001-1394**

#### Primary Fuel Injector Resistance

##### Connections to Injector

	Meter (+)	Meter (-)
#1:	W/R ↔	BL/R Terminal
#2:	W/R ↔	BL/G Terminal
#3:	W/R ↔	BL/BK Terminal
#4:	W/R ↔	BL/Y Terminal

**Standard: About 11.7 ~ 12.3 Ω at 20°C (68°F)**



## 3-98 FUEL SYSTEM (DFI)

### Fuel Injectors

#### Secondary Fuel Injector

- Remove the fuel tank (see Fuel Tank Removal in this chapter).
- Disconnect the connector from the injector [A] (see Nozzle Assy Removal in this chapter).
- Measure the injector resistance with the hand tester.

**Special Tool - Hand Tester: 57001-1394**

#### Secondary Fuel Injector Resistance Connections to Injectors

Meter (+)	Meter (-)
#1: W/R ↔	O/R Terminal
#2: W/R ↔	O/G Terminal
#3: W/R ↔	O/BK Terminal
#4: W/R ↔	O/Y Terminal

**Standard: About 11.1 ~ 12.3 Ω at 20°C (68°F)**

- ★ If the reading is out of the range, perform the "Injector Unit Test" in this chapter.
- ★ If the reading is normal, perform the "Injector Unit Test" for confirmation in this chapter.

#### Injector Unit Test

- Use two leads [A] and the same test light set [B] as in "Injector Signal Test" in this chapter.  
Rating of Bulb [C]: 12 V × (3 ~ 3.4) W  
12 V Battery [D]

#### CAUTION

**Be sure to connect the bulb in series. The bulb works as a current limiter to protect the solenoid in the injector from excessive current.**

- Connect the test light set to the injector [E] as shown.
- Open and connect [F] the end of the lead to the battery (-) terminal repeatedly. The injector should click.
- ★ If the injector does not click, replace the injector.

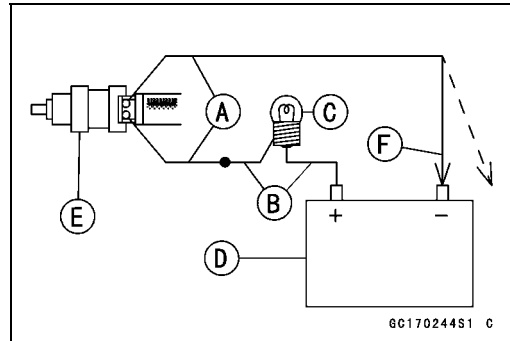
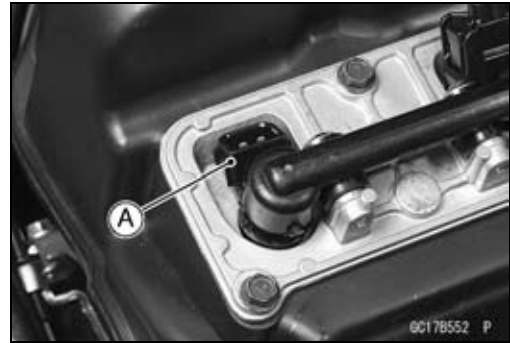

## Fuel Injectors

### Injector Voltage Inspection

#### NOTE

○Be sure the battery is fully charged.

- Turn the ignition switch OFF.
- Remove:
  - Fuel Tank (see Fuel Tank Removal in this chapter)
- Connect a digital voltmeter [A] to the connector [B], with the needle adapter set.

**Special Tool - Needle Adapter Set: 57001-1457**

#### Primary Fuel Injector Power Source Voltage

Connector to Injector #1, #2, #3, #4

Meter (+) → W/R lead

Meter (-) → Battery (-) Terminal

#### Secondary Fuel Injector Power Source Voltage

Connector to Injector #1, #2, #3, #4

Meter (+) → W/R lead

Meter (-) → Battery (-) Terminal

- Install the fuel tank (see Fuel Tank Installation in this chapter).
- Turn the ignition switch ON.

#### Power Source Voltage at Injector Connector

Standard: Battery Voltage (12.8 V or more)

- ★ If the power source voltage is less than standard, check the wiring (see wiring diagram in this section), fuel pump relay (see Fuel Pump Relay Inspection in this chapter) and ECU power source (see ECU Power Supply Inspection in this chapter).

- Turn the ignition switch OFF.
- Remove:
  - Fuel Tank (see Fuel Tank Removal in this chapter)
- Connect a digital voltmeter [A] to the connector [B], with the needle adapter set [C].

**Special Tool - Needle Adapter Set: 57001-1457**

#### Primary Fuel Injector Output Voltage

Connections to Injector #1

Meter (+) → BL/R lead

Meter (-) → Battery (-) Terminal

Connections to Injector #2

Meter (+) → BL/G lead

Meter (-) → Battery (-) Terminal

Connections to Injector #3

Meter (+) → BL/BK lead

Meter (-) → Battery (-) Terminal

Connections to Injector #4

Meter (+) → BL/Y lead

Meter (-) → Battery (-) Terminal

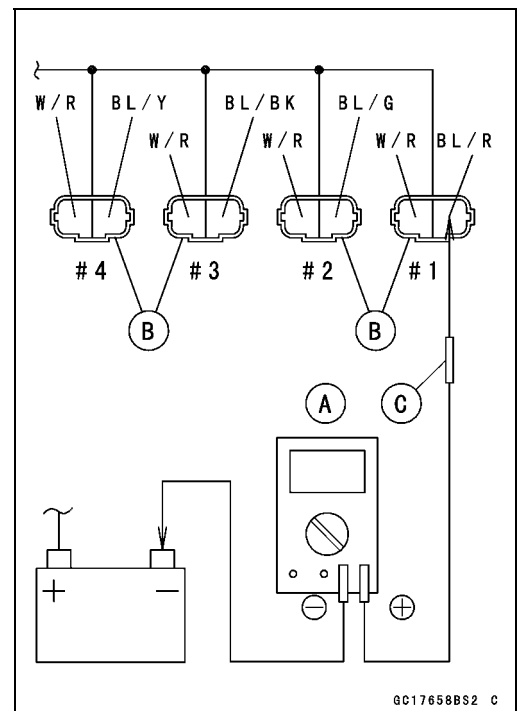
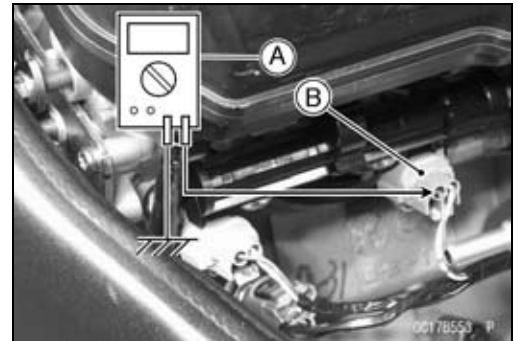

# 3-100 FUEL SYSTEM (DFI)

## Fuel Injectors

### Secondary Fuel Injector Output Voltage

#### Connections to Injector #1

Meter (+) → O/R lead

Meter (-) → Battery (-) Terminal

#### Connections to Injector #2

Meter (+) → O/G lead

Meter (-) → Battery (-) Terminal

#### Connections to Injector #3

Meter (+) → O/BK lead

Meter (-) → Battery (-) Terminal

#### Connections to Injector #4

Meter (+) → O/Y lead

Meter (-) → Battery (-) Terminal

- Install the fuel tank (see Fuel Tank Installation in this chapter).
- Turn the ignition switch ON.

### Output Voltage at Injector Connector

Standard: Battery Voltage (12.8 V or more)

### NOTE

○The secondary fuel injectors operating with following conditions.

Engine speeds is over 5 500 rpm (r/min)

Throttle opening is over 30°

- ★If the output voltage is out of the standard, replace the ECU (see ECU Removal/Installation in this chapter).

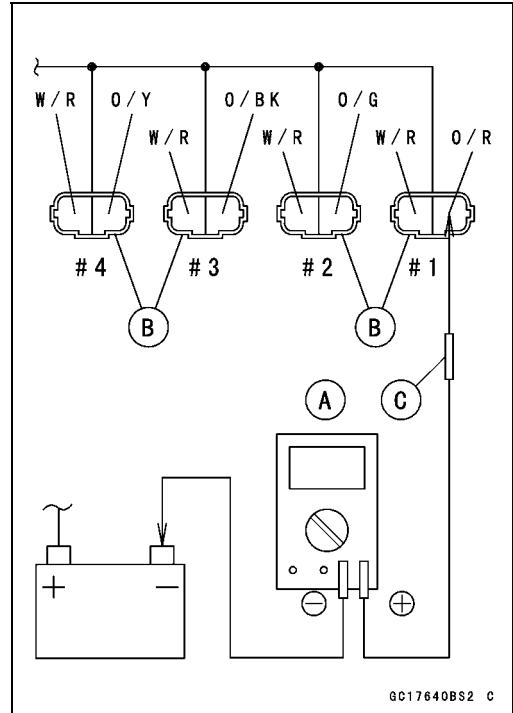

## Fuel Injectors

### Injector Fuel Line Inspection

- Remove the throttle body assy (see Throttle Body Assy Removal in this chapter).
- Remove the nozzle assy (see Nozzle Assy Removal in this chapter).
- Check the injector fuel line for leakage as follows:
  - Connect a commercially available vacuum/pressure pump [A] to the nipple of the delivery pipe [B] with the fuel hose [C] (both ends connected with the clamps [D]) as shown.
  - Apply soap and water solution to the areas [E] as shown.
  - Watching the pressure gauge, squeeze the pump lever [F], and build up the pressure until the pressure reaches the maximum pressure.

#### Fuel Line Maximum Pressure

Standard: 300 kPa (3.06 kgf/cm<sup>2</sup>, 43 psi)

### CAUTION

During pressure testing, do not exceed the maximum pressure for which the system is designed.

- Watch the gauge for at least 6 seconds.
- ★ If the pressure holds steady, the system is good.
- ★ If the pressure drops at once, or if bubbles are found in the area, the line is leaking. Replace the delivery pipe, injectors and related parts (see appropriate sections).
- Repeat the leak test, and check the fuel line for no leakage.
- Install the throttle body assy (see Throttle Body Assy Installation in this chapter).
- Install the nozzle assy (see Nozzle Assy Installation in this chapter).
- Run the hoses correctly (see Cable, Wire, and Hose Routing section in the Appendix chapter).

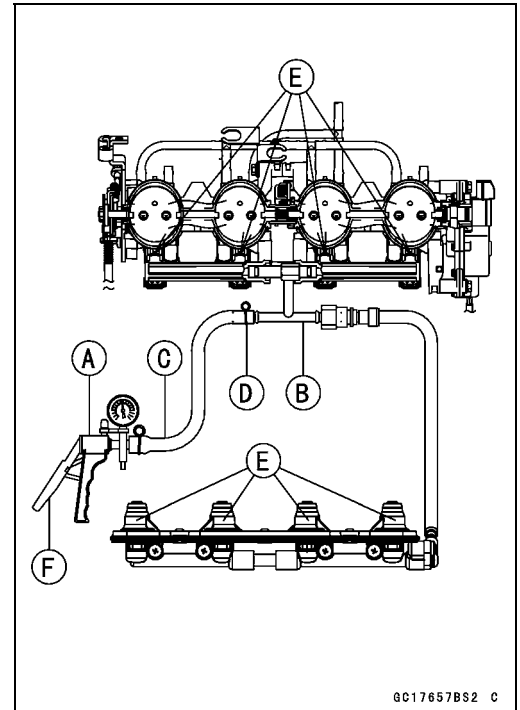

# 3-102 FUEL SYSTEM (DFI)

## Fuel Injectors

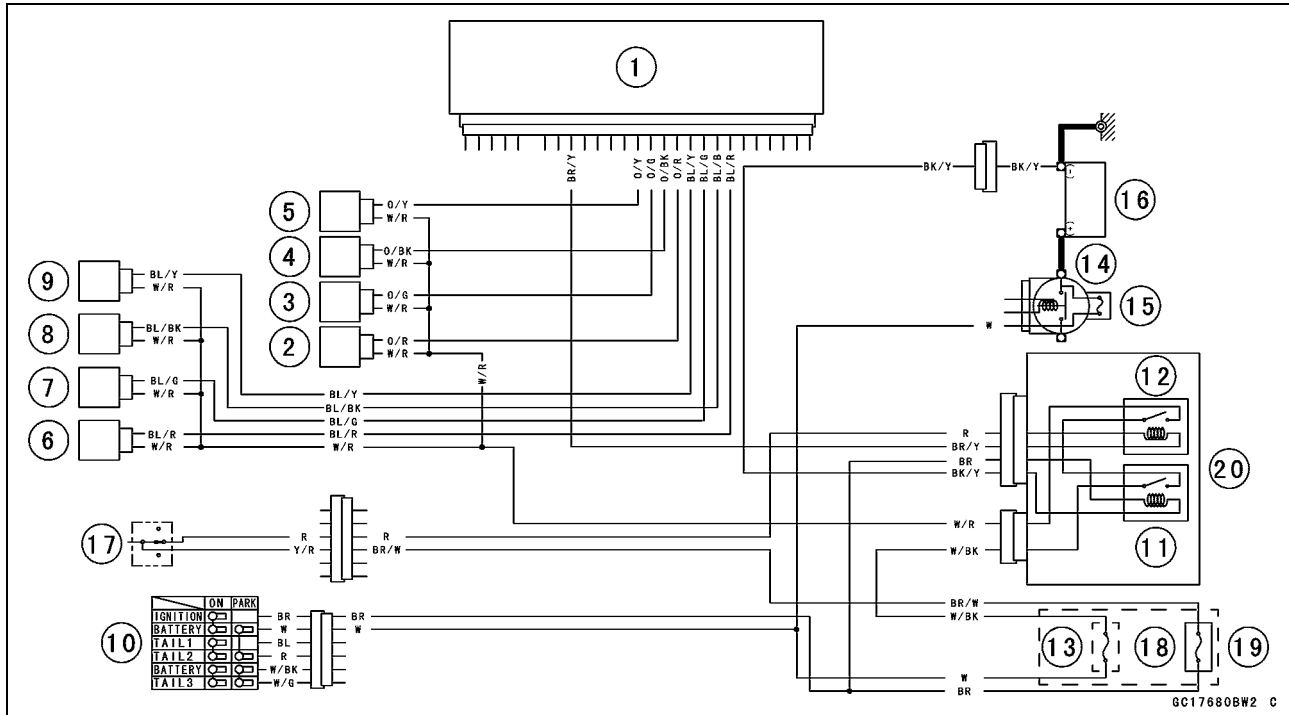

GC17680B#2 C

1. ECU
2. Secondary Fuel Injector #4
3. Secondary Fuel Injector #3
4. Secondary Fuel Injector #2
5. Secondary Fuel Injector #1
6. Primary Fuel Injector #4
7. Primary Fuel Injector #3
8. Primary Fuel Injector #2
9. Primary Fuel Injector #1
10. Ignition Switch
11. ECU Main Relay
12. Fuel Pump Relay
13. ECU Fuse 15 A
14. Main Fuse 30 A
15. Starter Relay
16. Battery 12 V 8 Ah
17. Engine Stop Switch
18. Ignition Fuse 10 A
19. Fuse Box
20. Relay Box

---

**Throttle Grip and Cables**

---

*Free Play Inspection*

- Refer to the Throttle Control System Inspection in the Periodic Maintenance chapter.

*Free Play Adjustment*

- Refer to the Throttle Control System Inspection in the Periodic Maintenance chapter.

*Cable Installation*

- Install the throttle cables in accordance with the Cable, Wire, and Hose Routing section in the Appendix chapter.
- Install the lower ends of the throttle cables in the cable bracket on the throttle body assy after installing the upper ends of the throttle cables in the grip.
- After installation, adjust each cable properly (see Free Play Adjustment in this chapter).

** WARNING**

**Operation with incorrectly routed or improperly adjusted cables could result in an unsafe riding condition.**

*Cable Lubrication*

- Refer to the Chassis Parts Lubrication in the Periodic Maintenance chapter.

## 3-104 FUEL SYSTEM (DFI)

### Throttle Body Assy

#### Idle Speed Inspection

- Refer to the Idle Speed Inspection in the Periodic Maintenance chapter .

#### Throttle Bore Cleaning

- Check the throttle bore for cleanliness as follows:
  - Remove:
    - Throttle Body Assy (see Throttle Body Assy Removal in the Fuel System (DFI) chapter)
  - Check the main throttle valves and throttle bores [A] for carbon deposits by opening the main throttle valves.
- ★ If any carbon accumulates, wipe the carbon off the throttle bores around the throttle bores and the throttle valves, using a cotton pad penetrated with a high-flash point solvent.

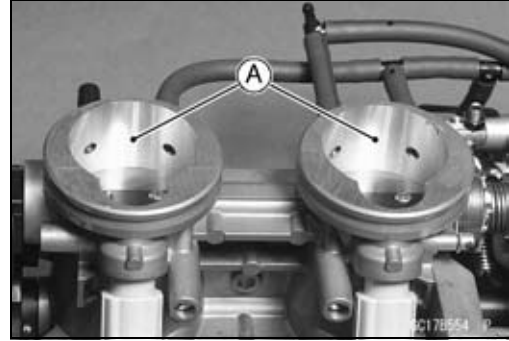

#### Synchronization Inspection

- Refer to the Engine Vacuum Synchronization Inspection in the Periodic Maintenance chapter.

#### Synchronization Adjustment

- Refer to the Engine Vacuum Synchronization Inspection in the Periodic Maintenance chapter.

#### Throttle Body Assy Removal

#### **⚠ WARNING**

**Gasoline is extremely flammable and can be explosive under certain conditions. Turn the ignition switch OFF. Disconnect the battery (-) cable terminal. Do not smoke. Make sure the area is well-ventilated and free from any source of flame or sparks; this includes any appliance with a pilot light.**

**Be prepared for fuel spillage: any spilled fuel must be completely wiped up immediately.**

- Remove:
  - Fuel Tank (see Fuel Tank Removal in this chapter)
  - Air Cleaner Housing (see Air Cleaner Housing Removal in this chapter)
- Be sure to place a piece of cloth around the fuel supply pipe of the throttle body assy.
- Disconnect:
  - Seven Connectors [A]

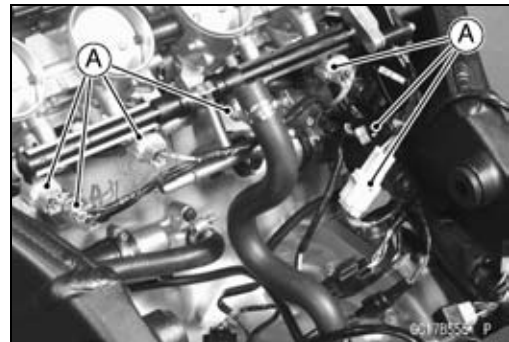

## Throttle Body Assy

- Remove:
  - Vacuum Switch Valve Vacuum Hose [A]
  - Vacuum Hose (California Model)
- Loosen:
  - Clamp Bolts [B]
- Remove the throttle body assy from the holder.

**CAUTION**

**When removing the throttle body assy, put the main throttle valves in the throttle bore, be careful to damage to valves.**

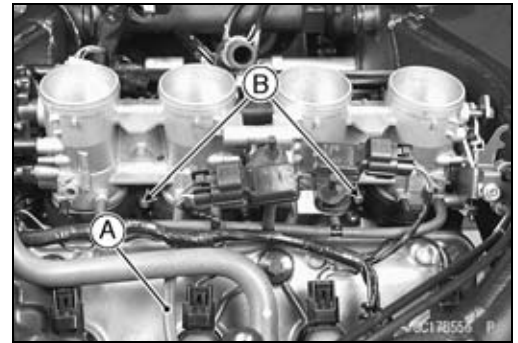

- Disconnect:
  - Three Connectors [A]



- Remove the throttle case [A] to make a throttle cable slack.
- Remove:
  - Throttle Cable Lower Ends



- After removing the throttle body assy, stuff pieces of lint-free, clean cloths into the throttle body holders.

**CAUTION**

**If dirt gets into the engine, excessive engine wear and possible engine damage will occur.**

# 3-106 FUEL SYSTEM (DFI)

## Throttle Body Assy

### Throttle Body Assy Installation

- Install the holder clamp bolts [A] in the direction as shown. Bolt Heads [B]
- Install the lower ends of the throttle cables in the throttle body assy, and install the throttle body assy.

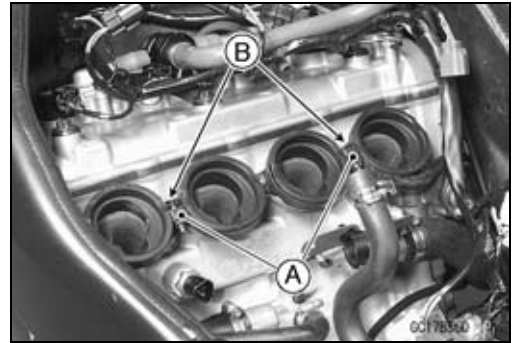

### CAUTION

**When installing the throttle body assy, put the main throttle valves in the throttle bore, be careful to damage to valves.**

- Tighten:  
**Torque - Throttle Body Assembly Holder Clamp Bolts: 3.0 N·m (0.30 kgf·m, 27 in·lb)**
- Install the removed connectors.
- Run the vacuum hoses as shown in the Cable, Wire, and Hose Routing section in the Appendix chapter.
- When installing the fuel hose, refer to Fuel Tank Installation in this chapter.
- Adjust:  
Throttle Grip Free Play (see Throttle Control System Inspection in the Periodic Maintenance chapter)  
Idle Speed (see Idle Speed Adjustment in the Periodic Maintenance chapter)

### Throttle Body Assy Disassembly

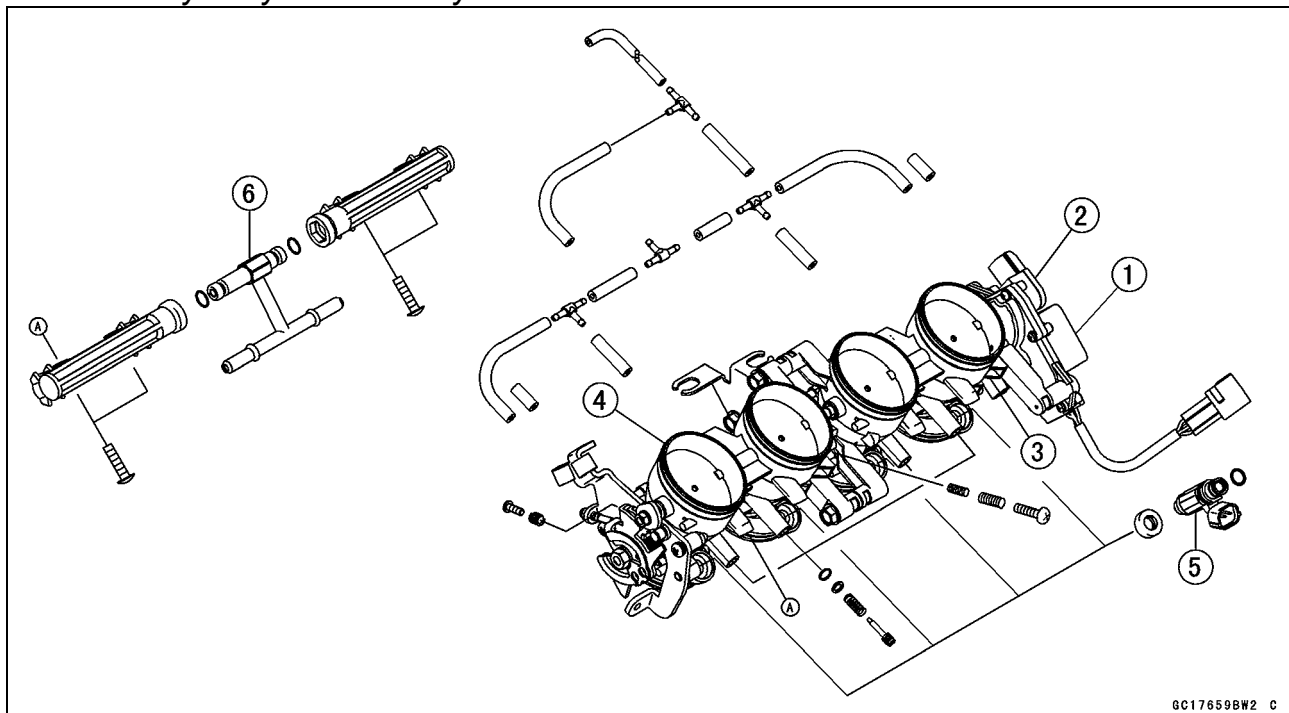

GC176598W2 C

1. Subthrottle Valve Actuator
2. Subthrottle Valve Sensor
3. Main Throttle Valve Sensor
4. Throttle Body Assy
5. Injector
6. Delivery Pipe Assy

## Throttle Body Assy

### CAUTION

Do not remove, disassemble or adjust the main throttle sensor, subthrottle sensor, subthrottle valve actuator, throttle link mechanism and throttle body assy, because they are adjust or set surely at the manufacturer. Adjustment of these parts could result in poor performance, requiring replacement of the throttle body assy.

- Remove the throttle body assy (see Throttle Body Assy Removal in this chapter).
- Remove the injector connectors.
- Remove the screws [A] to pull out the injector assys from the throttle body assy together with the delivery pipe [B].

### NOTE

○Do not damage the part of insert of the injectors when they are pulled out from the throttle body.

- Pull out the injectors [A] from the delivery pipe [B].

### NOTE

○Do not damage the part of insert of the injectors when they are pulled out from the delivery pipe.

### Throttle Body Assy Assembly

- Before assembling, blow away dirt or dust from the throttle body and delivery pipe by applying compressed air.
- Apply engine oil to the new O-rings [A] of each injector, insert them to the delivery pipe [B] and confirm whether the injectors turn smoothly or not.

### NOTE

○Replace the O-ring of injectors and the dust seals of delivery pipe to new one.

- Apply engine oil to the new dust seals [A], insert the injectors installed to the delivery pipe to the throttle body.

### NOTE

○Replace the dust seals of the throttle body to new one.

- Install the delivery pipe assy to the throttle body.

**Torque - Delivery Pipe Mounting Screws: 3.4 N·m (0.35 kgf·m, 30 in·lb)**

- Install the injector connectors to each injector.
- Insert the each hoses to the throttle body fittings.
- Install the throttle body assy (see Throttle Body Assy Installation in this chapter).

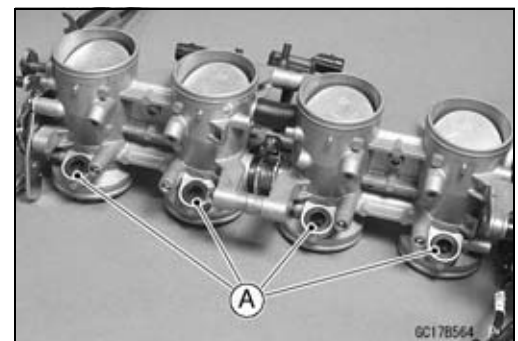
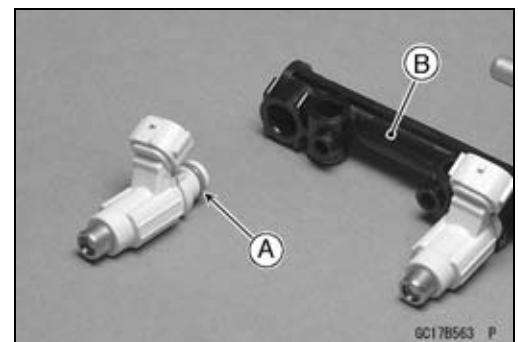
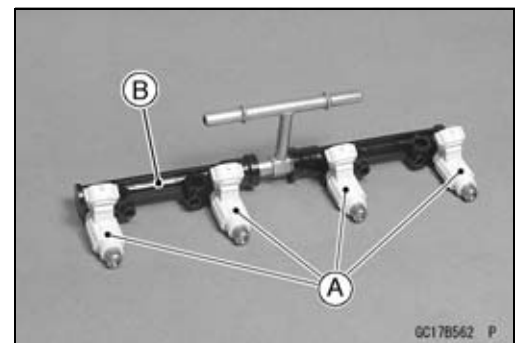
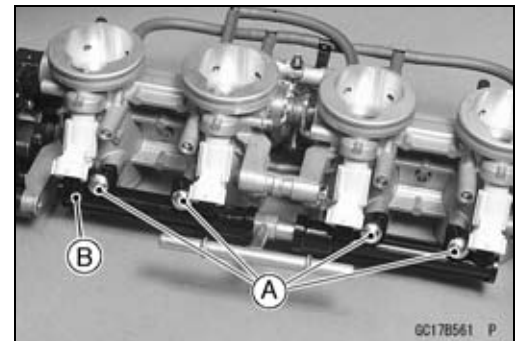

## 3-108 FUEL SYSTEM (DFI)

### Nozzle Assy

#### Nozzle Assy Removal

- Remove:
  - Fuel Tank (see Fuel Tank Removal in this chapter)
  - Nozzle Assy Lead Connectors [A]
  - Fuel Hose [B]
  - Nozzle Assy Mounting Bolts [C]
  - Nozzle Assy [D]

#### **⚠ WARNING**

**Be prepared for fuel spillage; any spilled fuel must be completely wiped up immediately. When the fuel hose is disconnected, fuel spills out from the hose and the pipe because of residual pressure. Cover the hose connection with a piece of clean cloth to prevent fuel spillage.**

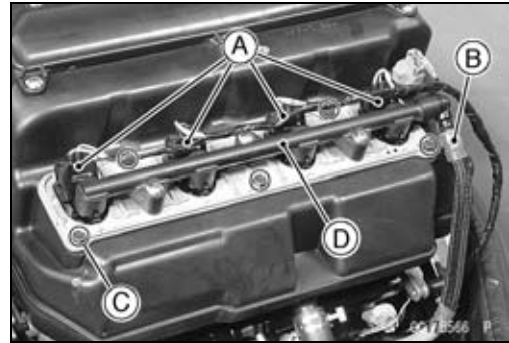

#### Nozzle Assy Installation

- Install the nozzle assy.
  - Torque - Nozzle Assy Mounting Bolts: 6.9 N·m (0.70 kgf·m, 61 in·lb)
- Install:
  - Nozzle Assy Lead Connectors
  - Fuel Hose (see Air Cleaner Housing Installation in this chapter)

#### **⚠ WARNING**

**Make sure the hose joint is installed correctly on the delivery pipe by sliding the joint, or the fuel could leak.**

#### Nozzle Assy Disassembly

- Remove the nozzle assy (see Nozzle Assy Removal in this chapter).
- Remove the screws [A] to pull out the injector assys from the stay plate comp together with the delivery pipe assy.

#### **NOTE**

○ Do not damage the part of insert of the injectors when they are pulled out from the stay plate comp.

- Remove the fuel hose.
- Pull out the injectors from the delivery pipe assy.

#### **NOTE**

○ Do not damage the part of insert of the injectors when they are pulled out from the delivery pipe assy.

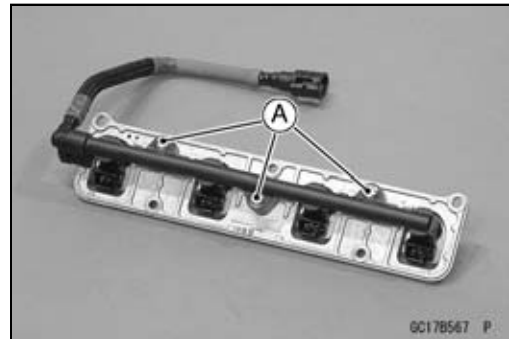

## Nozzle Assy

### Nozzle Assy Assembly

- Before assembling, blow away dirt or dust from the nozzle and delivery pipe assy [A] by applying compressed air [B].

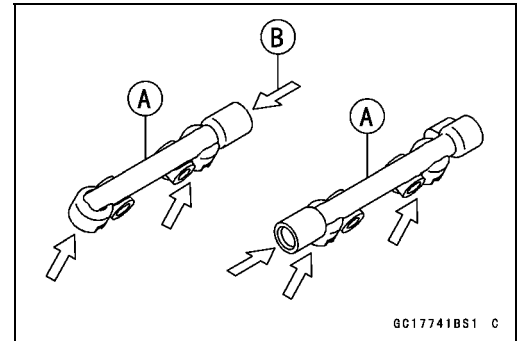

- Apply engine oil to the new O-rings [A] and the dust seals [B] of each injector.

### NOTE

○Replace the O-ring and the dust seals of injectors to new one.

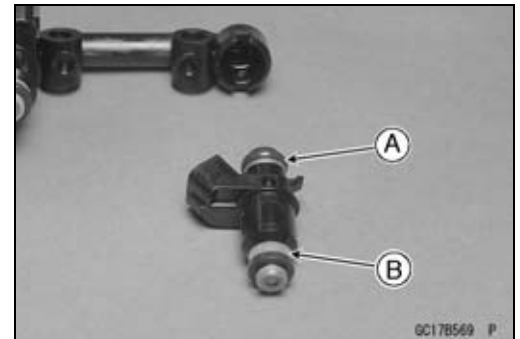

- Apply engine oil to the new O-rings [A].
- Install the joint pipe [B] to the delivery pipe.

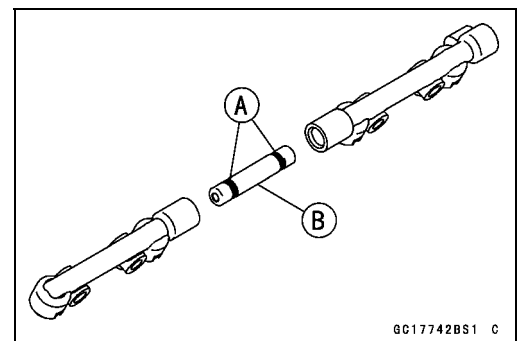

- Apply engine oil to the new O-rings [A].
- Fit the hook [B] of the injector to the slot [C] of delivery pipe.

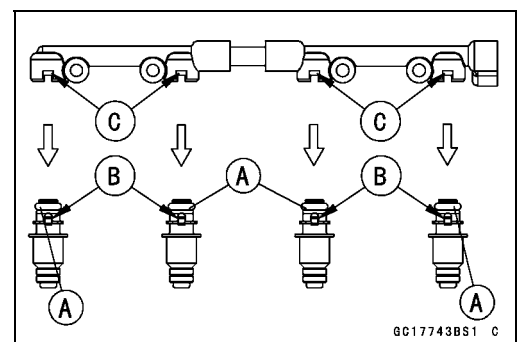

- Apply engine oil to the new dust seals [A].
- Insert the delivery pipe assy in the stay plate.

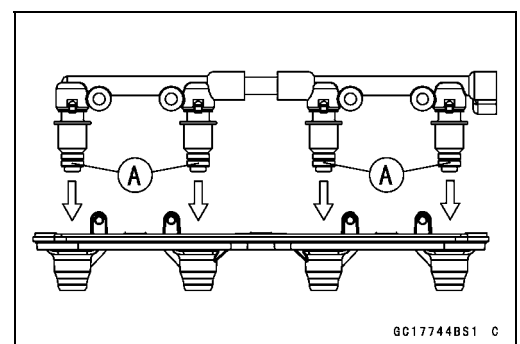

## 3-110 FUEL SYSTEM (DFI)

### Nozzle Assy

- Tighten the screws [A].

**Torque - Delivery Pipe Mounting Screws: 3.4 N·m (0.35 kgf·m, 30 in·lb)**

Stay Plate [B]

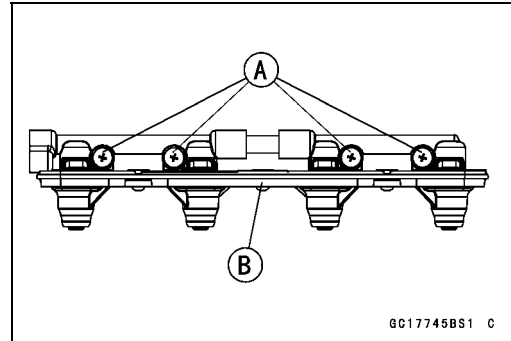

- Apply engine oil to the O-ring [A].

- Tighten:

**Torque - Fuel Hose Mounting Screw [B]: 4.9 N·m (0.50 kgf·m, 43 in·lb)**

- Check the injector fuel line for leakage (see Injector Fuel Line Inspection in this chapter).

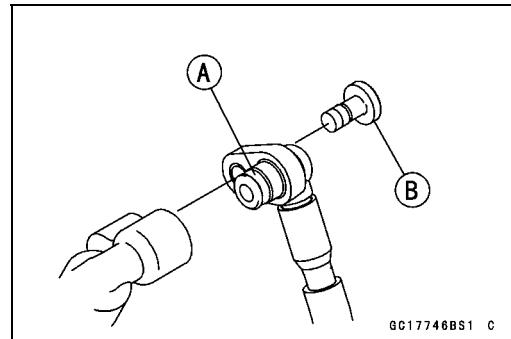

## Air Cleaner

### Element Removal

- Refer to the Air Cleaner Element Replacement in the Periodic Maintenance chapter.

### Element Installation

- Refer to the Air Cleaner Element Replacement in the Periodic Maintenance chapter.

### Air Cleaner Element Inspection

- Remove the air cleaner element (see Air Cleaner Element Replacement in the Periodic Maintenance chapter).
- Visually check the element [A] for tears or breaks.
- ★ If the element has any tears or breaks, replace the element.

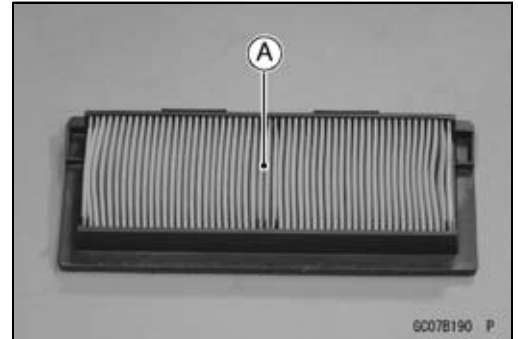

### Air Cleaner Housing Removal

- Remove:
  - Fuel Tank (see Fuel Tank Removal in this chapter)
  - Inlet Air Temperature Sensor [A]
  - Nozzle Assy Lead Connector [B]

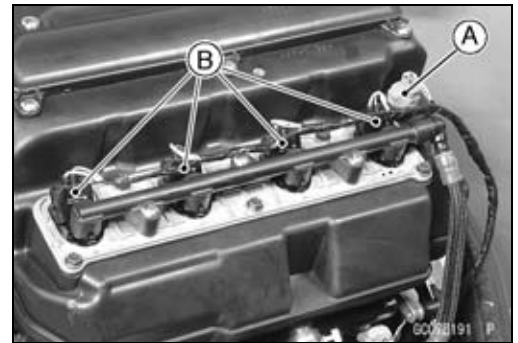

- Remove:
  - Air Cleaner Housing Clamp Bolts [A]

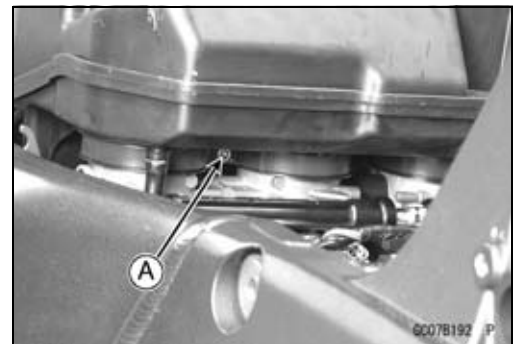

- Remove:
  - Air Cleaner Housing Bolt [A]

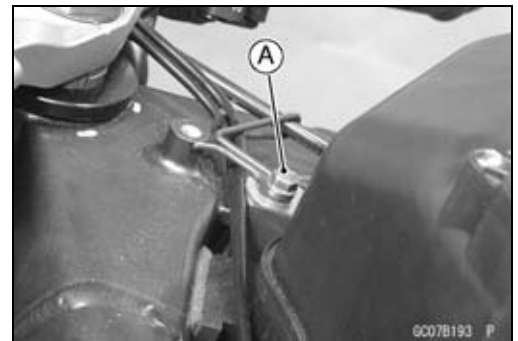

## 3-112 FUEL SYSTEM (DFI)

### Air Cleaner

- Remove the fuel hose [A].
- Remove the engine breather hose [B].



- Remove the drain hose.
- Remove the vacuum switch valve hose [A].



#### *Air Cleaner Housing Installation*

- Install the vacuum switch valve hose to the air cleaner housing.
- Install the air cleaner housing on the throttle body assy.

**Torque - Air Cleaner Housing Clamp Bolts: 2.0 N·m (0.20 kgf·m, 18 in·lb)**

**Air Cleaner Housing Mounting Bolt: 6.9 N·m (0.70 kgf·m, 60 in·lb)**

- Install the drain and engine breather hoses.
- Insert the fuel hose joint [A] straight onto the delivery pipe until the hose joint clicks.
- Push [B] the joint lock [C] until the hose joint clicks.
- Push and pull the hose joint back and forth more than two times and make sure it is locked and doesn't come off. When the hose joint is correctly installed, it should slide on the delivery pipe about 5 mm (0.2 in.).

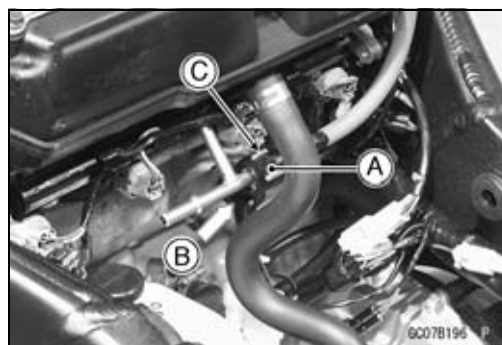

#### **⚠ WARNING**

**Make sure the hose joint is installed correctly on the delivery pipe by sliding the joint, or the fuel could leak.**

★ If it does not slide, reinstall the hose joint.

## Air Cleaner

### Air Cleaner Housing Disassembly

- Remove:
  - Air Cleaner Housing (see Air Cleaner Housing Removal in this chapter)
  - Ducts [A]



### Air Cleaner Housing Assembly

- Apply adhesive to the hatched area [A] on the duct.
  - Adhesive- Cemedine #540 or equivalent**
- After drying, apply adhesive to all mesh area [B] on the duct.
  - Adhesive- Cemedine 366 L or equivalent**
- Install:
  - Ducts [C]

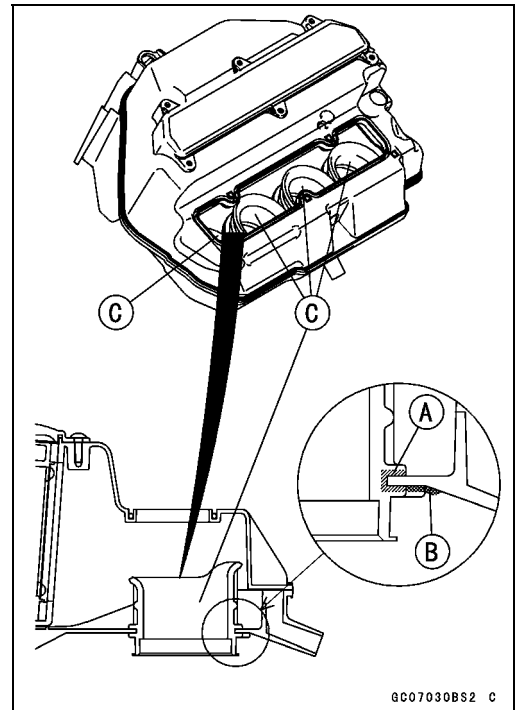

### Oil Draining

A drain hose is connected to the bottom of the air cleaner part to drain water or oil accumulated in the cleaner part.

- Visually check the drain hose end [A], if the water or oil accumulates in the hose.
- ★ If any water or oil accumulates in the hose, remove the tank [B] from the drain hose and drain it.

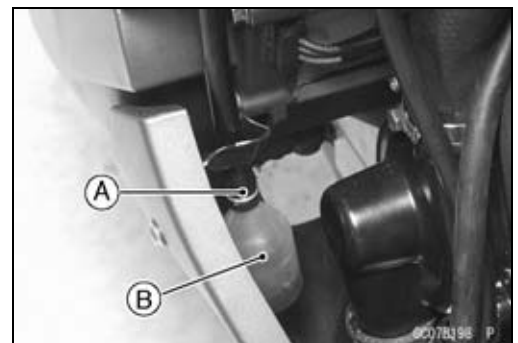

### **⚠ WARNING**

**Be sure reinstall the tank in the drain hose after draining. Oil on tires will make them slippery and can cause an accident and injury.**

### Air Inlet Duct Removal

- See Upper Fairing Removal/Disassembly in the Frame chapter.

### Air Inlet Duct Installation

- See Upper Fairing Assembly/Installation in the Frame chapter.

# 3-114 FUEL SYSTEM (DFI)

## Fuel Tank

### Fuel Tank Removal

#### **⚠ WARNING**

Gasoline is extremely flammable and can be explosive under certain conditions. Make sure the area is well-ventilated and free from any source of flame or sparks; this includes any appliance with a pilot light. Do not smoke. Turn the ignition switch OFF. Be prepared for fuel spillage; any spilled fuel must be completely wiped up immediately.

- Turn the ignition switch OFF.
- Remove:
  - Front Seat (see Front Seat Removal in the Frame chapter)
- Disconnect the battery (-) terminal.
- Wait until the engine cools down.
- Remove:
  - Fuel Tank Bolt [A]
  
- Remove:
  - Fuel Tank Bolts [A] (Both Side)
  - Fuel Tank Bolt [B]
  - Drain Hose
  - Connector [C]
  - Fuel Return Hose (Red, California model only)
  - Fuel Tank Breather Hose (Blue, California model only)
  
- Open the fuel tank cap [A] to lower the pressure in the tank.

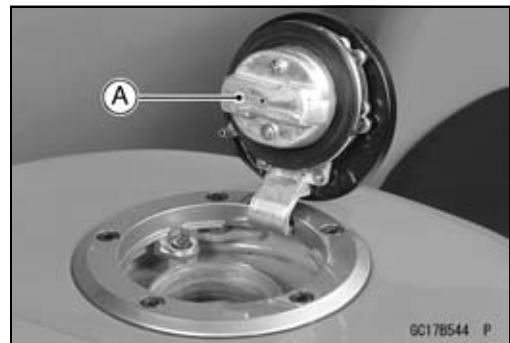
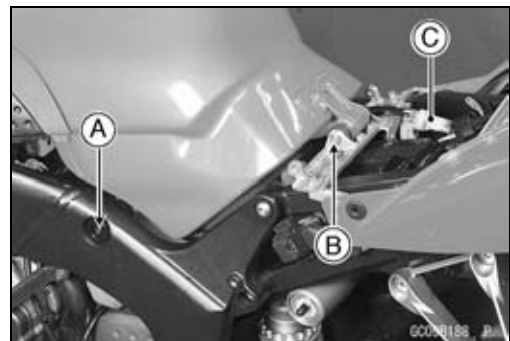
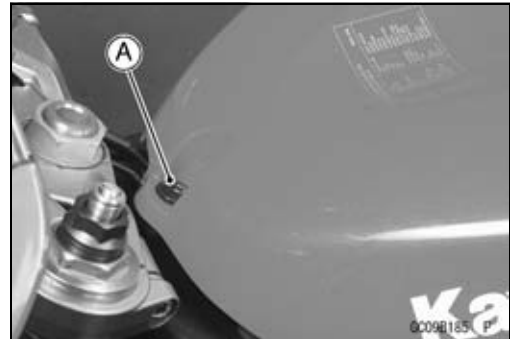

- Draw the fuel out from the fuel tank with a commercially available pump [A].
- Use a soft plastic hose [B] as a pump inlet hose in order to insert the hose smoothly.
- Put the hose through the fill opening [C] into the tank and draw the fuel out.
  - Front [D]

#### **⚠ WARNING**

The fuel could not be removed completely from the fuel tank. Be careful for remained fuel spillage.

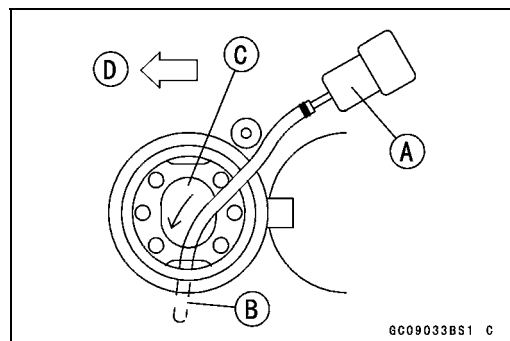

**Fuel Tank**

- Be sure to place a piece of cloth around the fuel hose joint [A].
- Push the joint lock claws [B].

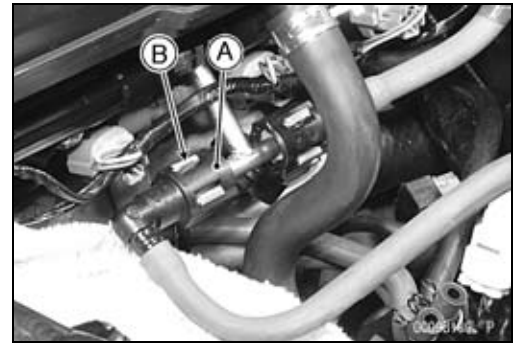

- Pull the joint lock [A] as shown.
- Pull the fuel hose joint [B] out of the delivery pipe.

**⚠ WARNING**

**Be prepared for fuel spillage; any spilled fuel must be completely wiped up immediately. When the fuel hose is disconnected, fuel spills out from the hose and the pipe because of residual pressure. Cover the hose connection with a piece of clean cloth to prevent fuel spillage.**

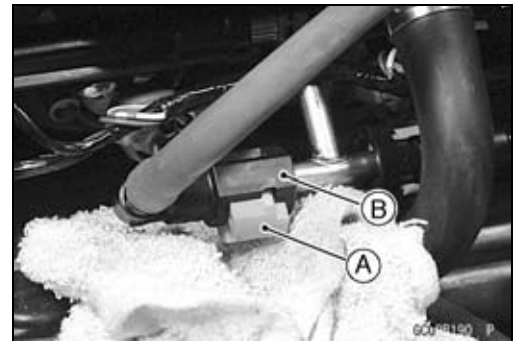

- Close the fuel tank cap.
- Remove the fuel tank, and place it on a flat surface.
- For California Model, note the following.

**CAUTION**

**For California model, if gasoline, solvent, water or any other liquid enters the canister, the canister's vapor absorbing capacity is greatly reduced. If the canister does become contaminated, replace it with a new one.**

- Be sure to plug the evaporative fuel return hose to prevent fuel spilling before fuel tank removal.

**⚠ WARNING**

**For California model, be careful not to spill the gasoline through the return hose. Spilled fuel is hazardous.**

- ★ If liquid or gasoline flows into the breather hose, remove the hose and blow it clean with compressed air.
- Be careful of fuel spillage from the fuel tank since fuel still remains in the fuel tank and fuel pump.

**⚠ WARNING**

**Store the fuel tank in an area which is well-ventilated and free from any source of flame or sparks. Do not smoke in this area. Place the fuel tank on a flat surface and plug the fuel pipes to prevent fuel leakage.**

## 3-116 FUEL SYSTEM (DFI)

### Fuel Tank

#### Fuel Tank Installation

- Note the above WARNING (see Fuel Tank Removal in this chapter).
- Route the hoses correctly (see Cable, Wire, and Hose Routing section in the Appendix chapter).
- For California Model, note the following.
  - To prevent the gasoline from flowing into or out of the canister, hold the separator perpendicular to the ground.
  - Connect the hoses according to the diagram of the system (see Cable, Wire, and Hose Routing section in the Appendix chapter). Make sure they do not get pinched or kinked.
  - Route hoses with a minimum of bending so that the air or vapor will not be obstructed.
- Pull [A] the joint lock as shown.

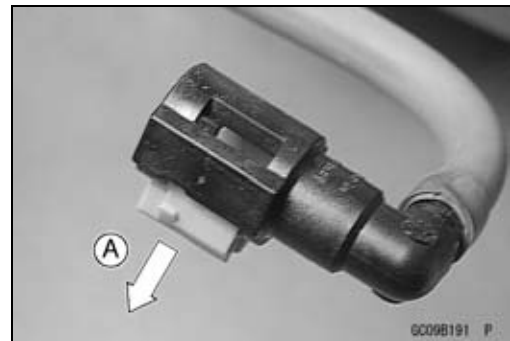

- Insert the fuel hose joint [A] straight onto the delivery pipe until the hose joint clicks.
- Push the joint lock [B] until the hose joint clicks.

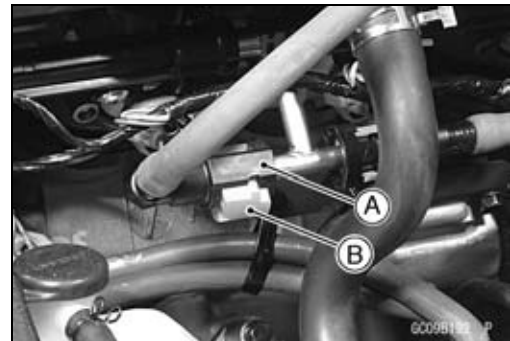

- Push and pull the hose joint [A] back and forth more than two times and make sure it is locked and doesn't come off. When the hose joint is correctly installed, it should slide on the delivery pipe about 5 mm (0.2 in.).

#### **⚠ WARNING**

**Make sure the hose joint is installed correctly on the delivery pipe by sliding the joint, or the fuel could leak.**

- ★ If it does not slide, reinstall the hose joint.
- Connect the fuel pump connector and the battery (-) cable terminal.



## Fuel Tank

### Fuel Tank and Cap Inspection

- Visually inspect the gasket [A] on the tank cap for any damage.
- ★ Replace the gasket if it is damaged.
- Check to see if the water drain pipe [B] and fuel breather pipe [C] (California Model) in the tank are not clogged. Check the tank cap breather also.
- ★ If they are clogged, remove the tank and drain it, and then blow the breather free with compressed air.

#### CAUTION

**Do not apply compressed air to the air vent holes [D] in the tank cap. This could cause damage and clogging of the labyrinth in the cap.**

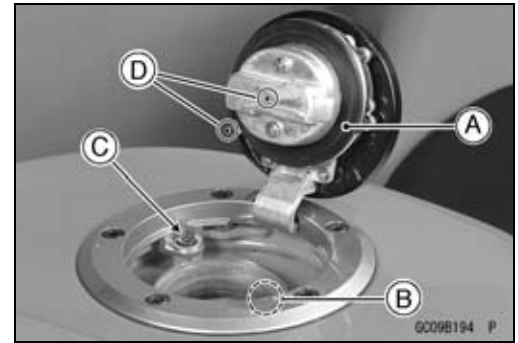

### Fuel Tank Cleaning

#### ⚠ WARNING

**Clean the tank in a well-ventilated area, and take care that there are no sparks or flame anywhere near the working area. Because of the danger or highly flammable liquids, do not use gasoline or low-flash point solvents to clean the tank.**

- Remove the fuel tank (see Fuel Tank Removal in this chapter).
- Remove the fuel pump (see Fuel Pump Removal in this chapter).
- Pour some high-flash point solvent into the fuel tank and shake the tank to remove dirt and fuel deposits.
- Draw the solvent out of the fuel tank.
- Dry the tank with compressed air.
- Install the fuel pump (see Fuel Pump Installation in this chapter).
- Install the fuel tank (see Fuel Tank Installation in this chapter).

## 3-118 FUEL SYSTEM (DFI)

### Evaporative Emission Control System (California Model)

The Evaporative Emission Control System routes fuel vapors from the fuel system into the running engine or stores the vapors in a canister when the engine is stopped. Although no adjustments are required, a thorough visual inspection must be made at the intervals specified by the Periodic Maintenance Chart.

#### Parts Removal/Installation

#### **⚠ WARNING**

**Gasoline is extremely flammable and can be explosive under certain conditions. Turn the ignition switch OFF. Do not smoke. Make sure the area is well-ventilated and free from any source of flame or sparks; this includes any appliance with a pilot light.**

#### **CAUTION**

**If gasoline, solvent, water or any other liquid enters the canister, the canister's vapor absorbing capacity is greatly reduced. If the canister does become contaminated, replace it with a new one.**

- To prevent the gasoline from flowing into or out of the canister, hold the separator perpendicular to the ground.
- Connect the hoses according to the diagram of the system (see Cable, Wire, and Hose Routing section in the Appendix chapter). Make sure they do not get pinched or kinked.

#### *Hose Inspection*

- Refer to the Evaporative Emission Control System Inspection in the Periodic Maintenance chapter.

#### *Separator Inspection*

- Refer to the Evaporative Emission Control System Inspection in the Periodic Maintenance chapter.  
Separator [A]



Evaporative Emission Control System (California Model)

Separator Operation Test

**⚠ WARNING**  
**Gasoline is extremely flammable and can be explosive under certain conditions. Turn the ignition switch OFF. Do not smoke. Make sure the area is well-ventilated and free from any source of flame or sparks; this includes any appliance with a pilot light.**

- Connect the hoses to the separator, and install the separator on the motorcycle.
- Disconnect the breather hose from the separator, and inject about 20 mL (0.68 US oz.) of gasoline [A] into the separator [B] through the hose fitting.
- Disconnect the fuel return hose [C] from the fuel tank [D].
- Run the open end of the return hose into the container and hold it level with the tank top [E].
- Start the engine, and let it idle.
- ★ If the gasoline in the separator comes out of the hose, the separator works well. If it does not, replace the separator with a new one.

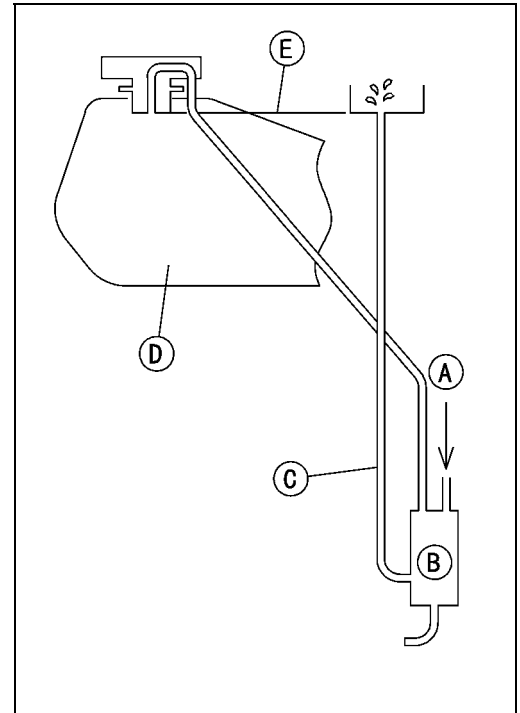

Canister Inspection

- Refer to the Evaporative Emission Control System Inspection in the Periodic Maintenance chapter.

**NOTE**

○ The canister [A] is designed to work well through the motorcycle's life without any maintenance if it is used under normal conditions.





# Cooling System

## Table of Contents

Exploded View .....	4-2
Specifications .....	4-4
Special Tools and Sealant .....	4-5
Coolant Flow Chart.....	4-6
Coolant .....	4-8
Coolant Deterioration Inspection.....	4-8
Coolant Level Inspection.....	4-8
Coolant Draining .....	4-8
Coolant Filling .....	4-8
Pressure Testing .....	4-8
Cooling System Flushing .....	4-9
Coolant Reserve Tank Removal .....	4-9
Coolant Reserve Tank Installation .....	4-9
Water Pump.....	4-10
Water Pump Removal .....	4-10
Water Pump Installation.....	4-10
Water Pump Impeller Disassembly/Assembly .....	4-10
Water Pump Impeller Inspection .....	4-10
Water Pump Housing Disassembly .....	4-10
Water Pump Housing Assembly .....	4-11
Mechanical Seal Inspection .....	4-11
Radiator .....	4-12
Radiator and Radiator Fan Removal .....	4-12
Radiator and Radiator Fan Installation .....	4-13
Radiator Inspection .....	4-17
Radiator Cap Inspection .....	4-17
Radiator Filler Neck Inspection .....	4-18
Thermostat .....	4-19
Thermostat Removal.....	4-19
Thermostat Installation.....	4-19
Thermostat Inspection .....	4-20
Hoses and Pipes .....	4-22
Hose Installation .....	4-22
Hose Inspection .....	4-22
Water Temperature Sensor .....	4-23
Water Temperature Sensor Removal.....	4-23
Water Temperature Sensor Inspection .....	4-23

# 4-2 COOLING SYSTEM

## Exploded View

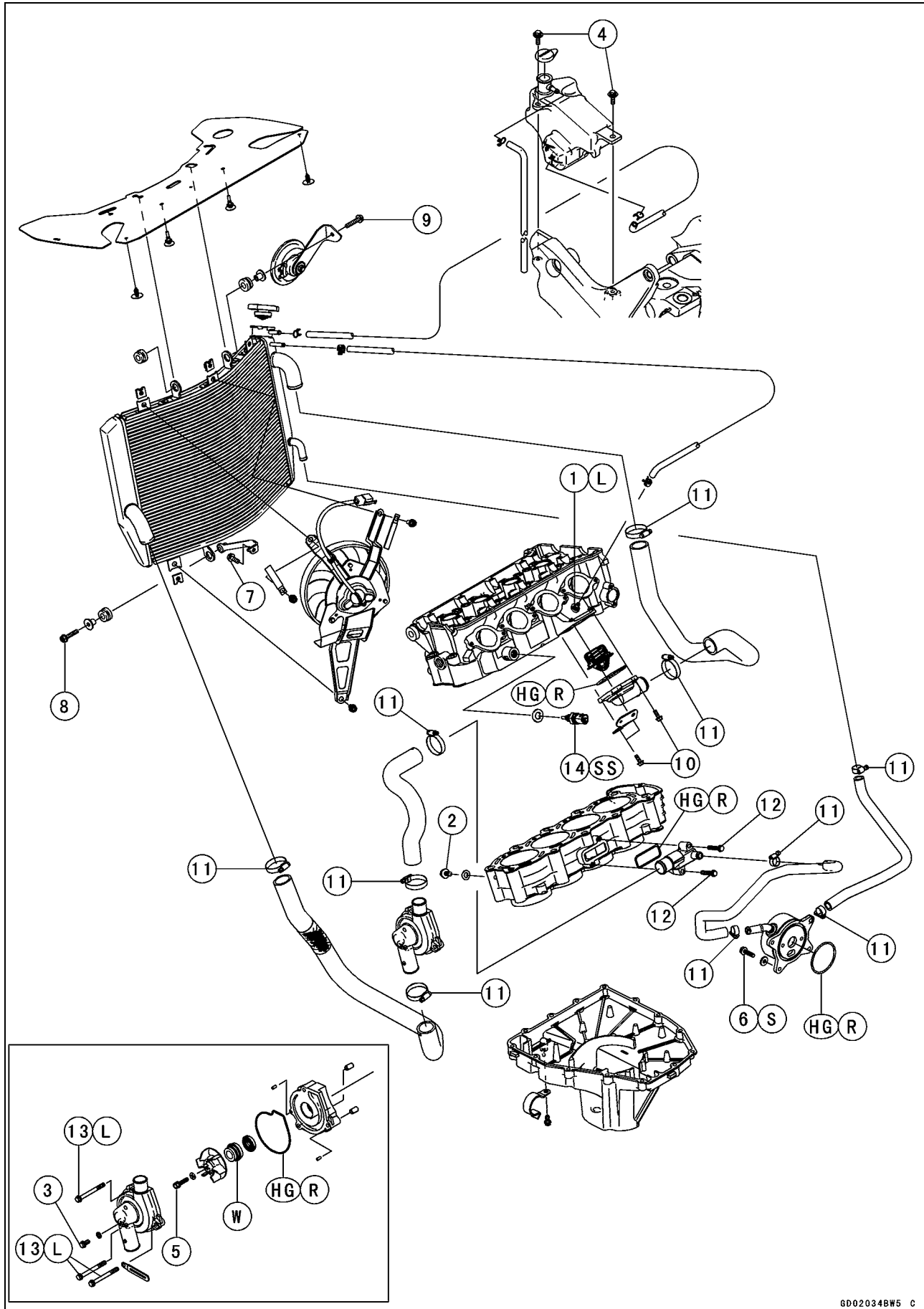

**Exploded View**

No.	Fastener	Torque			Remarks
		N·m	kgf·m	ft·lb	
1	Coolant By-pass Fitting Bolt	8.8	0.90	78 in·lb	L
2	Coolant Drain Bolt (Cylinder)	9.8	1.0	87 in·lb	
3	Coolant Drain Bolt (Water Pump)	8.8	0.90	78 in·lb	
4	Coolant Reserve Tank Mounting Bolts	6.9	0.70	61 in·lb	
5	Impeller Bolt	9.8	1.0	87 in·lb	
6	Oil Cooler Mounting Bolts	12	1.2	104 in·lb	S
7	Radiator Bracket Mounting Bolt	6.9	0.70	61 in·lb	
8	Radiator Lower Bolt	6.9	0.70	61 in·lb	
9	Radiator Upper Bolt	12	1.2	104 in·lb	
10	Thermostat Housing Cover Bolts	5.9	0.60	52 in·lb	
11	Water Hose Clamp Screws	2.0	0.20	17 in·lb	
12	Water Hose Fitting Bolts	12	1.2	104 in·lb	
13	Water Pump Cover Bolts	12	1.2	104 in·lb	L
14	Water Temperature Sensor	25	2.5	18	SS

HG: Apply high-temperature grease.

L: Apply a non-permanent locking agent.

R: Replacement Parts

S: Follow the specific tightening sequence.

SS: Apply silicone sealant.

W: Apply water.

## 4-4 COOLING SYSTEM

### Specifications

Item	Standard
<b>Coolant Provided when Shipping</b> Type (Recommended) Color Mixed Ratio Freezing Point Total Amount	Permanent type of antifreeze (soft water and ethylene glycol plus corrosion and rust inhibitor chemicals for aluminum engines and radiators) Green Soft water 50%, coolant 50% -35°C (-31°F) 2.6 L (2.7 US qt) (Reserve tank full level, including radiator and engine)
<b>Radiator Cap</b> Relief Pressure	93 ~ 123 kPa (0.95 ~ 1.25 kgf/cm <sup>2</sup> , 14 ~ 18 psi)
<b>Thermostat</b> Valve Opening Temperature Valve Full Opening Lift	58 ~ 62°C (136 ~ 144°F) 8 mm (0.31 in.) or more @75°C (167°F)

**Special Tools and Sealant**

**Bearing Driver,  $\phi$ 32:  
57001-382**

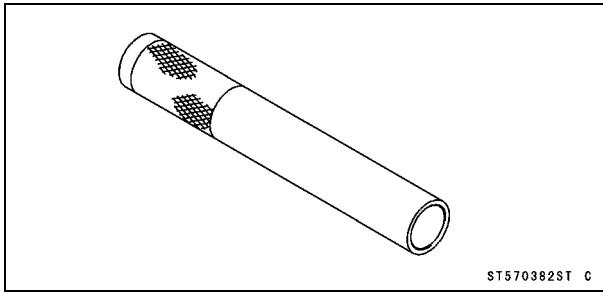

**Kawasaki Bond (Silicone Sealant):  
56019-120**

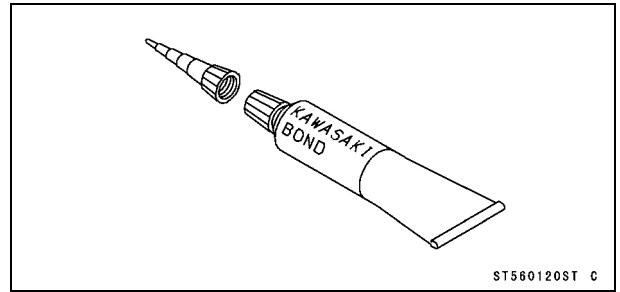

**Bearing Driver Set:  
57001-1129**

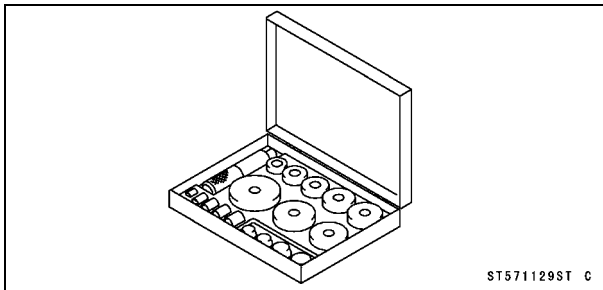

# 4-6 COOLING SYSTEM

## Coolant Flow Chart

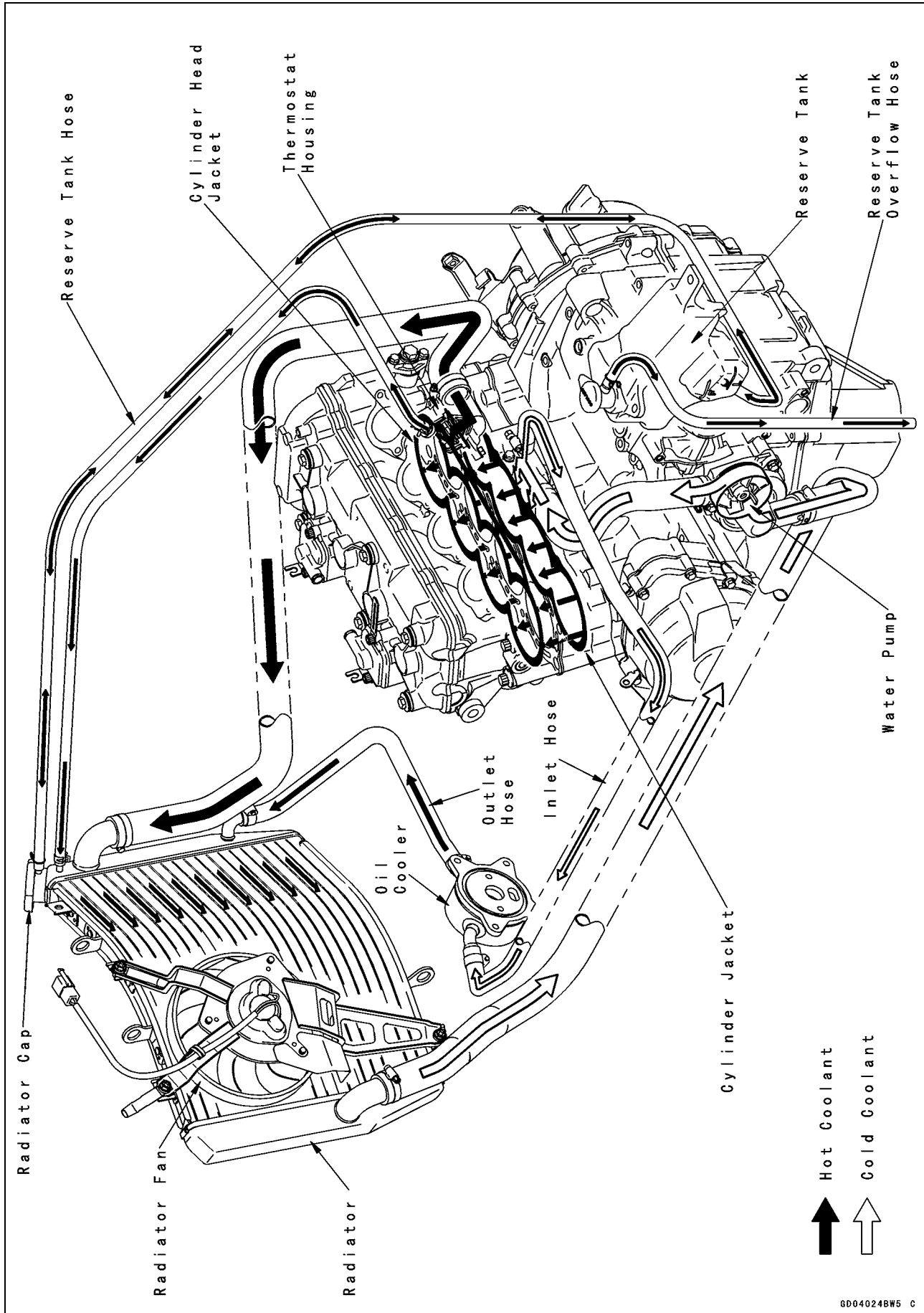

---

**Coolant Flow Chart**

---

Permanent type antifreeze is used as a coolant to protect the cooling system from rust and corrosion. When the engine starts, the water pump turns and the coolant circulates.

The thermostat is a wax pellet type which opens or closes with coolant temperature changes. The thermostat continuously changes its valve opening to keep the coolant temperature at the proper level. When coolant temperature is less than 55°C (131°F), the thermostat closes so that the coolant flow is restricted through the air bleeder hole, causing the engine to warm up more quickly. When coolant temperature is more than 58 ~ 62°C (136 ~ 144°F), the thermostat opens and the coolant flows.

When the coolant temperature goes up beyond 95°C (203°F), the radiator fan relay conducts to operate the radiator fan. The radiator fan draws air through the radiator core when there is not sufficient air flow such as at low speeds. This increases up the cooling action of the radiator. When the coolant temperature is below 90°C (194°F), the fan relay opens and the radiator fan stops.

In this way, this system controls the engine temperature within narrow limits where the engine operates most efficiently even if the engine load varies.

The system is pressurized by the radiator cap to suppress boiling and the resultant air bubbles which can cause engine overheating. As the engine warms up, the coolant in the radiator and the water jacket expands. The excess coolant flows through the radiator cap and hose to the reserve tank to be stored there temporarily. Conversely, as the engine cools down, the coolant in the radiator and the water jacket contracts, and the stored coolant flows back to the radiator from the reserve tank.

The radiator cap has two valves. One is a pressure valve which holds the pressure in the system when the engine is running. When the pressure exceeds 93 ~ 123 kPa (0.95 ~ 1.25 kgf/cm<sup>2</sup>, 14 ~ 18 psi), the pressure valve opens and releases the pressure to the reserve tank. As soon as pressure escapes, the valve closes, and keeps the pressure at 93 ~ 123 kPa (0.95 ~ 1.25 kgf/cm<sup>2</sup>, 14 ~ 18 psi). When the engine cools down, another small valve (vacuum valve) in the cap opens. As the coolant cools, the coolant contracts to form a vacuum in the system. The vacuum valve opens and allows the coolant from the reserve tank to enter the radiator.

## 4-8 COOLING SYSTEM

### Coolant

#### *Coolant Deterioration Inspection*

- Visually inspect the coolant in the reserve tank.
- ★ If whitish cotton-like wafts are observed, aluminum parts in the cooling system are corroded. If the coolant is brown, iron or steel parts are rusting. In either case, flush the cooling system.
- ★ If the coolant gives off an abnormal smell, check for a cooling system leak. It may be caused by exhaust gas leaking into the cooling system.

#### *Coolant Level Inspection*

- Refer to the Coolant Level Inspection in the Periodic Maintenance chapter.

#### *Coolant Draining*

- Refer to the Coolant Change in the Periodic Maintenance chapter.

#### *Coolant Filling*

- Refer to the Coolant Change in the Periodic Maintenance chapter.

#### *Pressure Testing*

- Remove the right upper inner fairing (see Upper Inner Fairing Removal in the Frame chapter).
- Remove the radiator cap, and install the cooling system pressure tester [A] on the filler neck.

#### **NOTE**

○ Wet the cap sealing surfaces with water or coolant to prevent pressure leaks.

- Build up pressure in the system carefully until the pressure reaches 123 kPa (1.25 kgf/cm<sup>2</sup>, 18 psi).

#### **CAUTION**

**During pressure testing, do not exceed the pressure for which the system is designed. The maximum pressure is 123 kPa (1.25 kgf/cm<sup>2</sup>, 18 psi).**

- Watch the gauge for at least 6 seconds.
- ★ If the pressure holds steady, the system is all right.
- ★ If the pressure drops and no external source is found, check for internal leaks. Droplets in the engine oil indicate internal leakage. Check the cylinder head gasket and the water pump.
- Remove the pressure tester, replenish the coolant, and install the radiator cap.

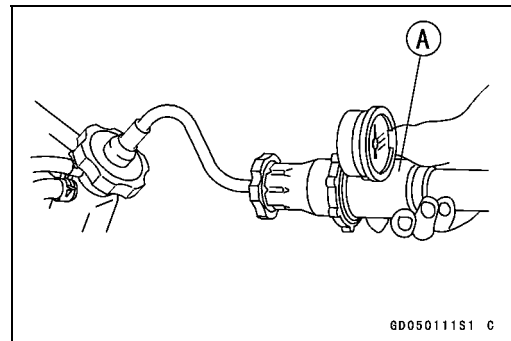

## Coolant

### Cooling System Flushing

Over a period of time, the cooling system accumulates rust, scale, and lime in the water jacket and radiator. When this accumulation is suspected or observed, flush the cooling system. If this accumulation is not removed, it will clog up the water passage and considerably reduce the efficiency of the cooling system.

- Drain the coolant (see Coolant Change in the Periodic Maintenance chapter).
- Fill the cooling system with fresh water mixed with a flushing compound.

### CAUTION

**Do not use a flushing compound which is harmful to the aluminum engine and radiator. Carefully follow the instructions supplied by the manufacturer of the cleaning product.**

- Warm up the engine, and run it at normal operating temperature for about ten minutes.
- Stop the engine, and drain the cooling system.
- Fill the system with fresh water.
- Warm up the engine and drain the system.
- Repeat the previous two steps once more.
- Fill the system with a permanent type coolant and bleed the air from the system (see Coolant Change in the Periodic Maintenance chapter).

### Coolant Reserve Tank Removal

- Remove:
  - Left Center Fairing (see Center Fairing Removal in the Frame chapter)
  - Fuel Tank (see Fuel Tank Removal in the Fuel System (DFI) chapter)
  - Coolant Reserve Tank Mounting Bolts [A]
  - Coolant Reserve Tank [B]

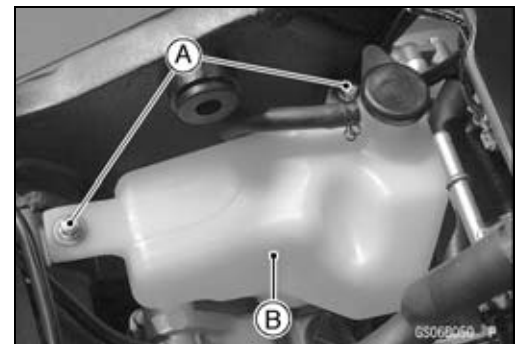

### Coolant Reserve Tank Installation

- Install:
  - Coolant Reserve Tank
- Tighten:
  - Torque - Coolant Reserve Tank Mounting Bolts: 6.9 N·m (0.70 kgf·m, 61 in·lb)**

## 4-10 COOLING SYSTEM

### Water Pump

#### Water Pump Removal

- Refer to the Oil Pump Removal in the Engine Lubrication System chapter.

#### Water Pump Installation

- Refer to the Oil Pump Installation in the Engine Lubrication System chapter.

#### Water Pump Impeller Disassembly/Assembly

- The sealing seat and rubber seal may be removed easily by hand.
- Apply coolant around the surfaces of the rubber seal and sealing seat.
- Install the rubber seal [A] and sealing seat [B] into the impeller by pressing them by hand until the seat stops at the bottom of the hole.
- Tighten the impeller bolt by special torque.

**Torque - Impeller Bolt: 9.8 N·m (1.0 kgf·m, 87 in·lb)**

#### Water Pump Impeller Inspection

- Check the drainage outlet passage [A] at the bottom of the water pump body for coolant leaks.
- ★ If the mechanical seal is damaged, the coolant leaks through the seal and drains through the passage. Replace the mechanical seal unit (see Water Pump Housing Disassembly/Assembly in this chapter).

- Visually inspect the impeller [A].
- ★ If the surface is corroded, or if the blades are damaged, replace the impeller.

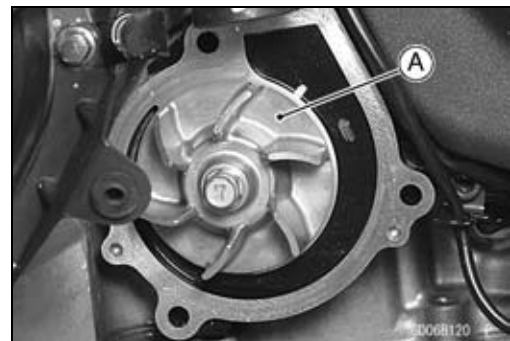
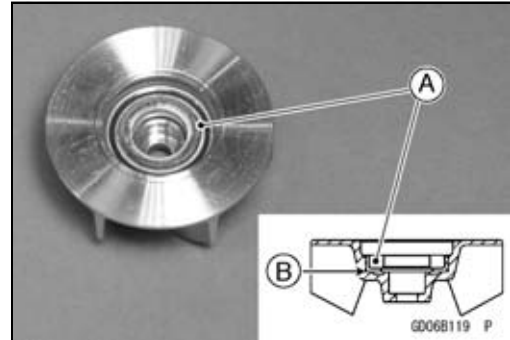

#### Water Pump Housing Disassembly

##### CAUTION

**Do not damage the hole wall of the water pump housing.**

- Insert a bar [A] into the pump housing [B], and hammer evenly around the circumference of the mechanical seal bottom [C].

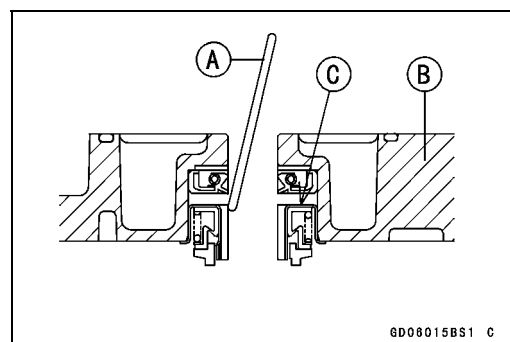

**Water Pump**

- Take the oil seal [A] out of the housing [B] with a hook [C].

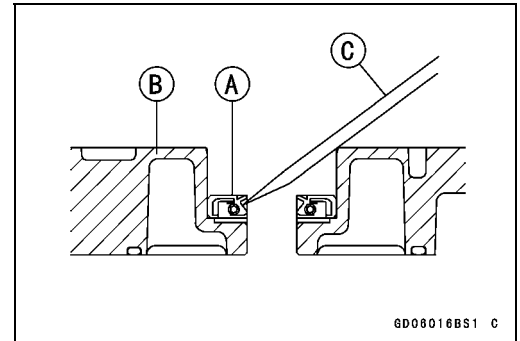

*Water Pump Housing Assembly*

**CAUTION**

**Do not reuse the mechanical seal and oil seal.**

- Apply high-temperature grease to the oil seal lips [A].
- Press the new oil seal into the housing with a bearing driver [B] until it stops at the bottom surface [C] of the housing.

**Special Tool - Bearing Driver Set: 57001-1129**

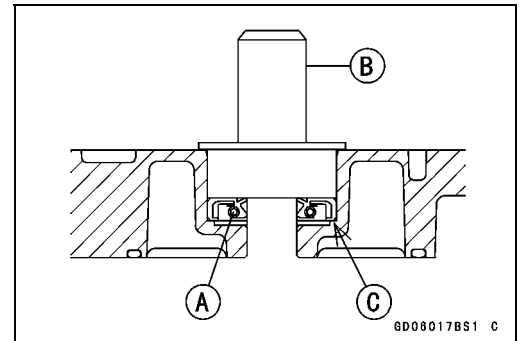

**CAUTION**

**Be careful not to damage the sealing surface of the mechanical seal.**

- Press the new mechanical seal into the housing with stem bearing driver [A] until its flange [B] touches the surface [C] of the housing.

**Special Tool - Bearing Driver,  $\phi$ 32: 57001-382**

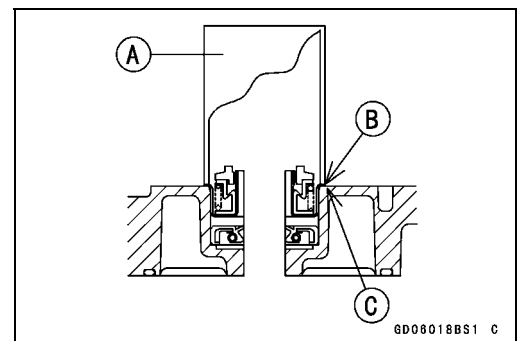

*Mechanical Seal Inspection*

- Visually inspect the mechanical seal.
- ★ If any one of the parts is damaged, replace the mechanical seal as a unit.

Impeller Sealing Seat Surface [A]

Rubber Seal [B]

Mechanical Seal [C]

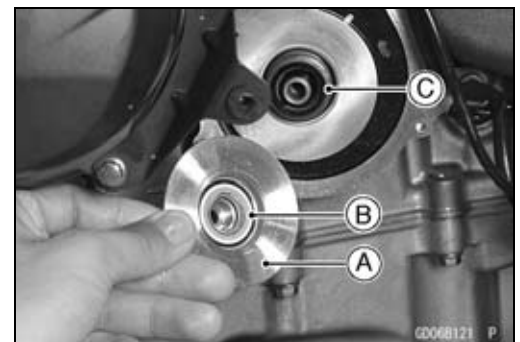

## 4-12 COOLING SYSTEM

### Radiator

#### *Radiator and Radiator Fan Removal*

- Remove:
  - Coolant (Drain, see Coolant Change in the Periodic Maintenance chapter)
  - Air Cleaner Housing (see Air Cleaner Housing Removal in the Fuel System (DFI) chapter)
  - Radiator Fan Lead Connector [A]
  
- Remove:
  - Bolt [A]
  
- Remove:
  - Radiator Hoses [A]
  
- Remove:
  - Radiator Hoses [A]
  - Radiator Upper Bolt [B]
  
- Remove:
  - Radiator Lower Bolt [A]
  - Radiator Hose [B]
- Pull the radiator from the projection, and remove the radiator.

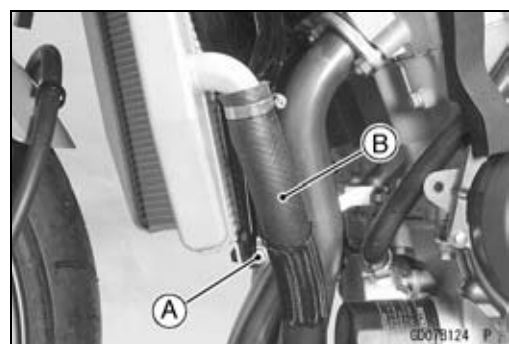
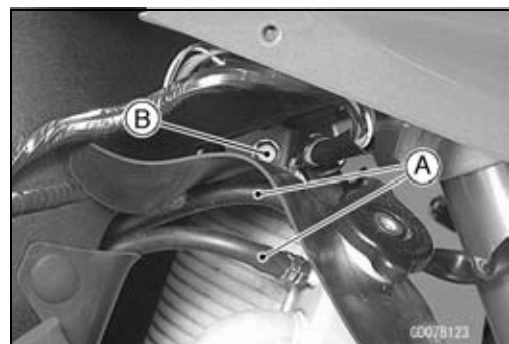
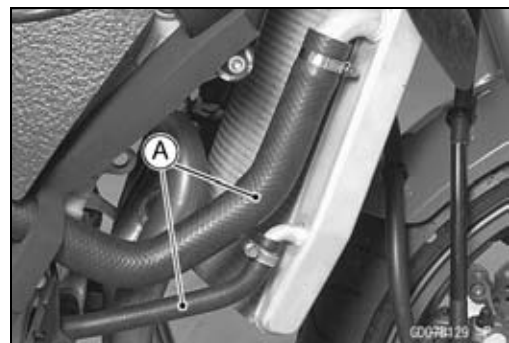

#### **CAUTION**

**Do not touch the radiator core. This could damage the radiator fins, resulting in loss of cooling efficiency.**

## Radiator

- Remove:
  - Radiator Fan Mounting Bolts [A]
  - Radiator Fan [B]

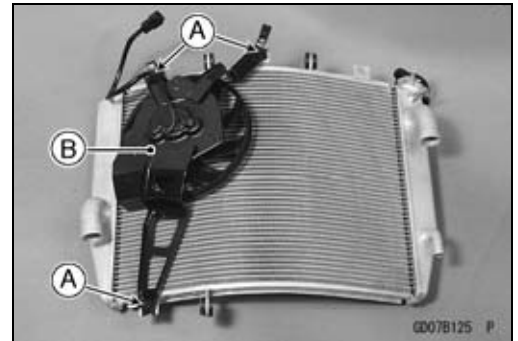

### *Radiator and Radiator Fan Installation*

- Insert the plugs [A] in the holes of heat insulation rubber plate [B].

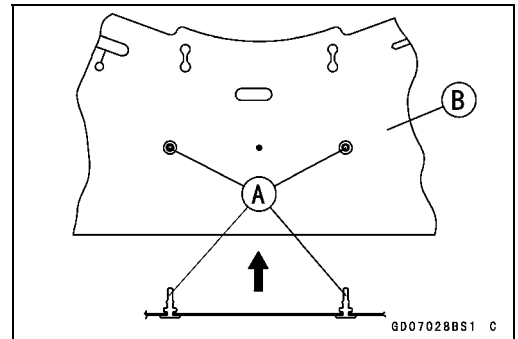

- Install the heat insulation rubber plate [C] on the engine.
- Install the plug in the clamp [A] of air suction valve cover. Front [B]

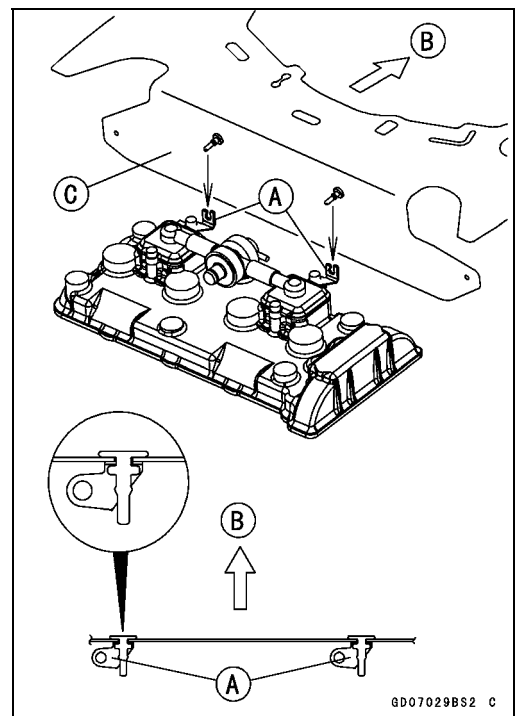

## 4-14 COOLING SYSTEM

### Radiator

- Cover [A] the heat insulation rubber plate on the radiator.
- Install the radiator to the projection [B] as shown.

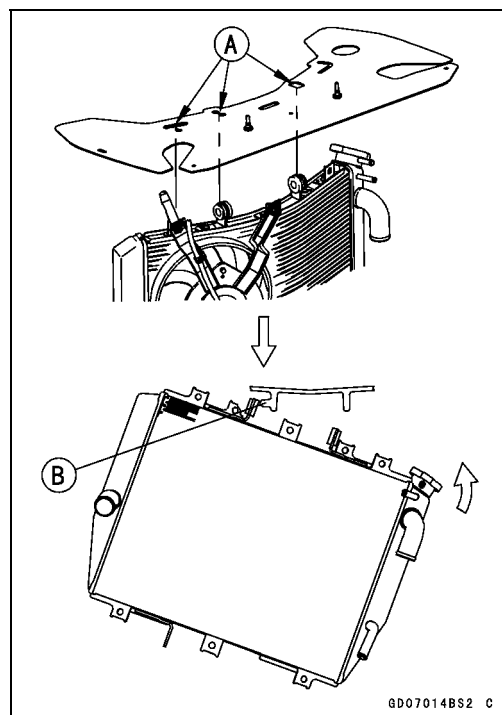

## Radiator

- Enchase the heat insulation rubber plate [A] to the radiator stay.
- Through the radiator fan lead [B] in the heat insulation rubber plate hole, and clamp the radiator fan lead and horn lead [C] with the radiator clamp [D].
- Clamp the immobilizer antenna lead [E] and ignition switch lead [F].
- Enchase the heat insulation rubber plate to the radiator cap [G].
- Hang down [H] the heat insulation rubber plate forward of cylinder head cover.
- After the hang down, bend [I] the heat insulation rubber plate outside of engine mount, and insert the rivets [J] (both side).
- Hang the hole [K] of heat insulation rubber plate to the tang [L] of the center fairing.

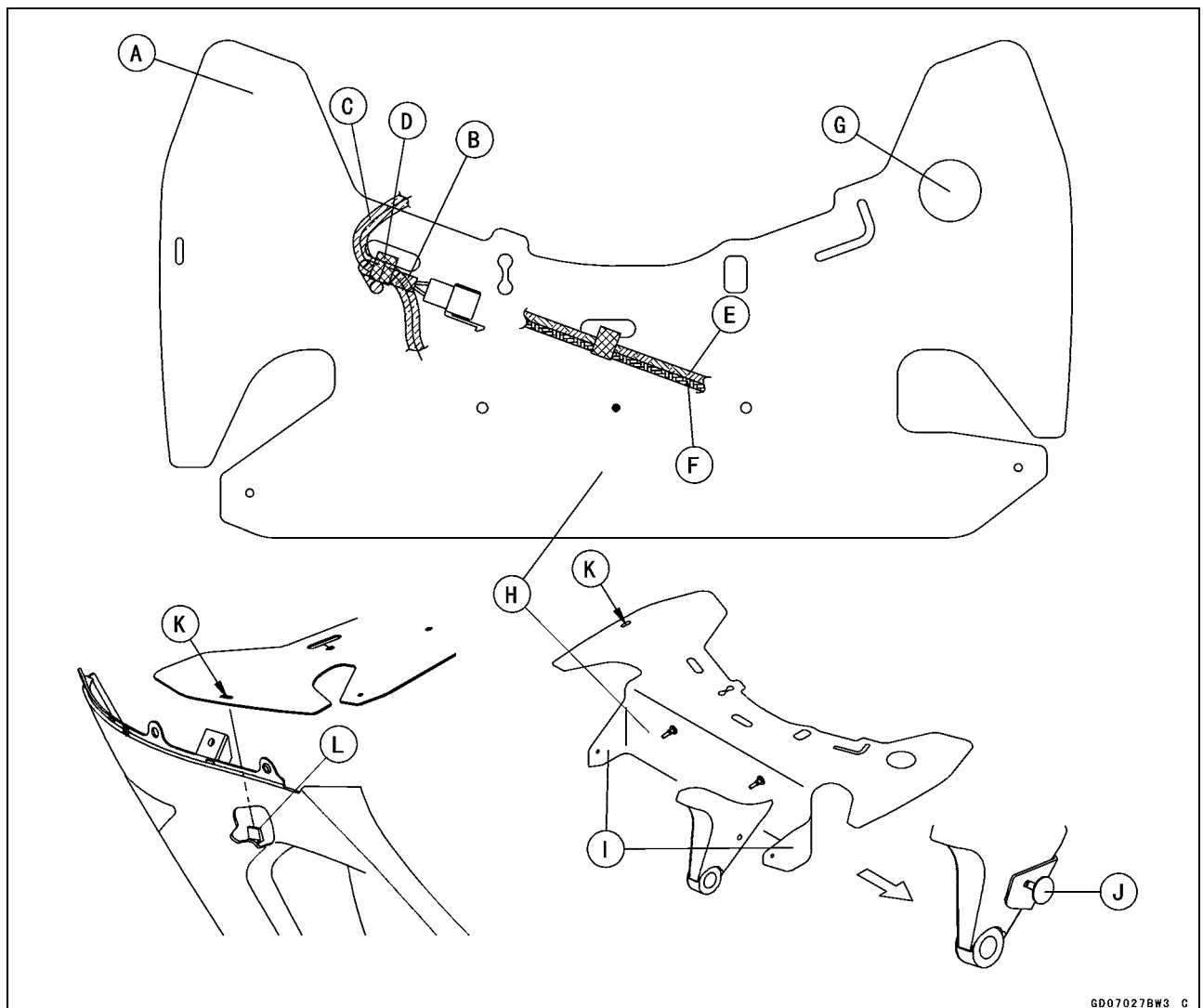

## 4-16 COOLING SYSTEM

### Radiator

- Install the radiator bracket collar [A] as shown.  
Rubber Damper [B]  
Radiator [C]  
Horn [D]  
Harness Stay [E]  
Bolt [F]
- Tighten:  
**Torque - Radiator Upper Bolt [G]: 12 N·m (1.2 kgf·m, 104 in·lb)**  
**Radiator Lower Bolt [H]: 6.9 N·m (0.70 kgf·m, 61 in·lb)**
- Install the water hose clamp [I].
- Tighten:  
**Torque - Water Hose Clamp Screws: 2.0 N·m (0.20 kgf·m, 17 in·lb)**

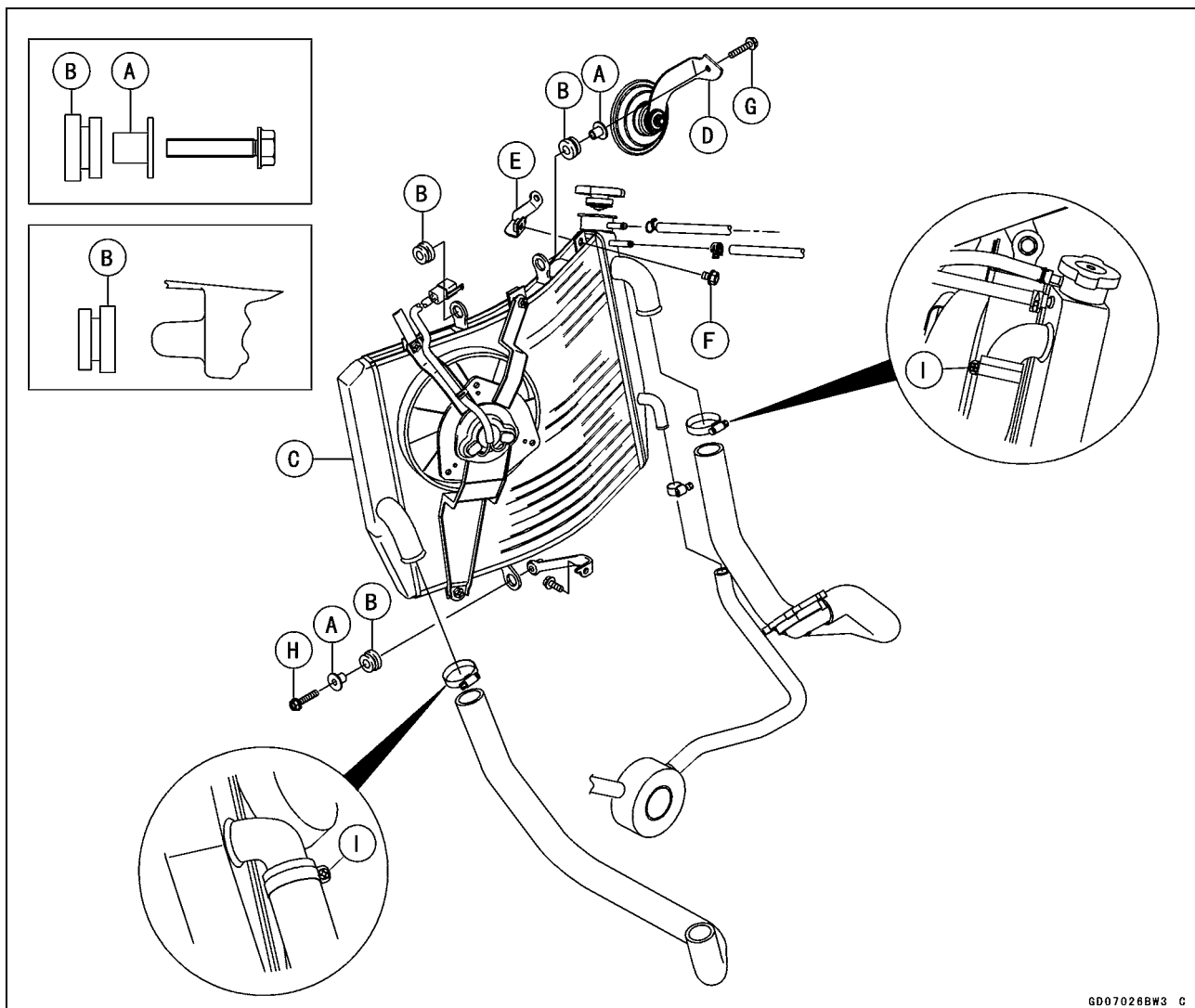

## Radiator

### Radiator Inspection

- Remove the radiator (see Radiator and Radiator Fan Removal in this chapter).
- Check the radiator core.
- ★ If there are obstructions to air flow, remove them.
- ★ If the corrugated fins [A] are deformed, carefully straighten them.
- ★ If the air passages of the radiator core are blocked more than 20% by unremovable obstructions or irreparably deformed fins, replace the radiator with a new one.

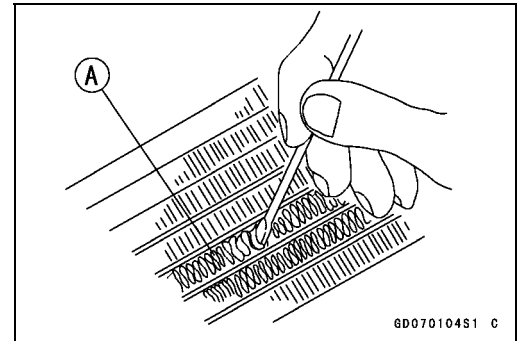

### CAUTION

When cleaning the radiator with steam cleaner, be careful of the following to prevent radiator damage: Keep the steam gun [A] away more than 0.5 m (1.6 ft) [B] from the radiator core. Hold the steam gun perpendicular [C] (not oblique [D]) to the core surface. Run the steam gun, following the core fin direction.

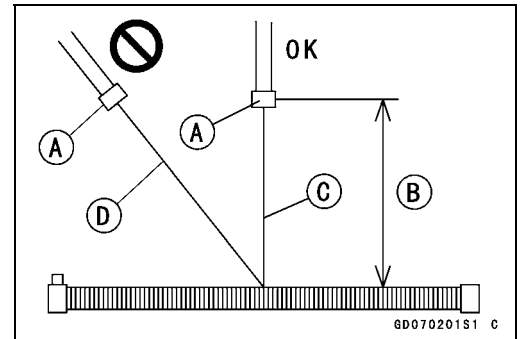

### Radiator Cap Inspection

- Remove:
    - Right Upper Inner Fairing (see Upper Inner Fairing Removal in the Frame chapter)
    - Radiator Cap
  - Check the condition of the bottom [A] and top [B] valve seals and valve spring [C].
  - ★ If any one of them shows visible damage, replace the cap with a new one.
- Install the cap [A] on a cooling system pressure tester [B].

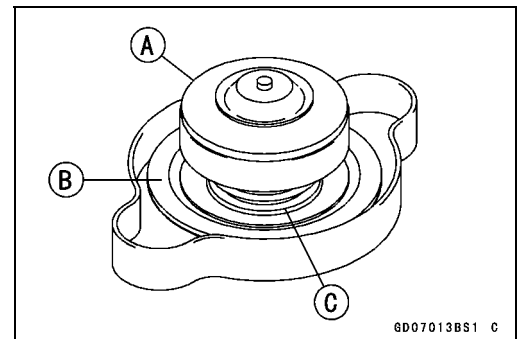

### NOTE

- Wet the cap sealing surfaces with water or coolant to prevent pressure leaks.
- Watching the pressure gauge, pump the pressure tester to build up the pressure until the relief valve opens: the gauge needle flicks downward. Stop pumping and measure leak time at once. The relief valve must open within the specified range in the table below and the gauge hand must remain within the same range at least 6 seconds.

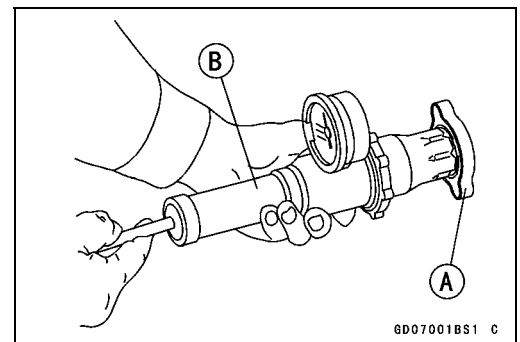

### Radiator Cap Relief Pressure

Standard: 93 ~ 123 kPa (0.95 ~ 1.25 kgf/cm<sup>2</sup>, 14 ~ 18 psi)

- ★ If the cap can not hold the specified pressure or if it holds too much pressure, replace it with a new one.

## 4-18 COOLING SYSTEM

### Radiator

#### *Radiator Filler Neck Inspection*

- Remove the right upper inner fairing (see Upper Inner Fairing Removal in the Frame chapter).
- Remove the radiator cap.
- Check the radiator filler neck for signs of damage.
- Check the condition of the top and bottom sealing seats [A] in the filler neck. They must be smooth and clean for the radiator cap to function properly.



## Thermostat

### Thermostat Removal

- Drain the coolant (see Coolant Change in the Periodic Maintenance chapter).
- Remove:
  - Fuel Tank (see Fuel Tank Removal in the Fuel System (DFI) chapter)
  - Throttle Body Assy (see Throttle Body Assy Removal in the Fuel System (DFI) chapter)
  - Thermostat Housing Cover Bolts [A]
  - Bracket [B]
  - Thermostat Housing Cover [C]
  - Thermostat

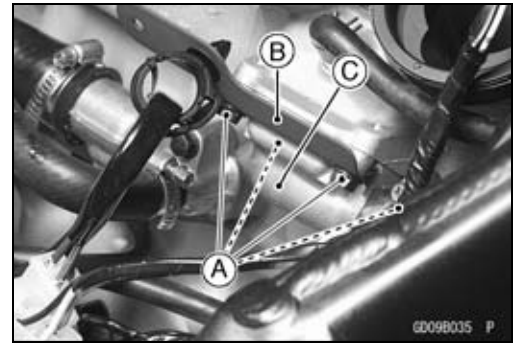

### Thermostat Installation

- Install the thermostat [A] in the housing so that the air bleeder hole [B] is on top.

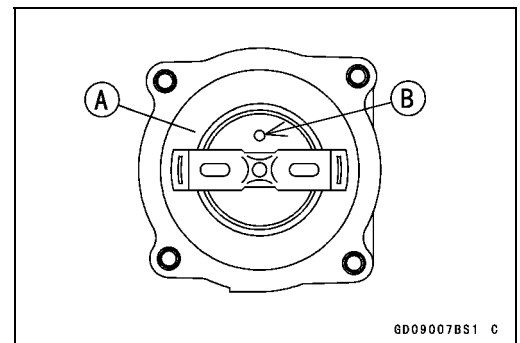

- Apply high-temperature grease to the new O-ring [A].
- Install a new O-ring into the housing cover.

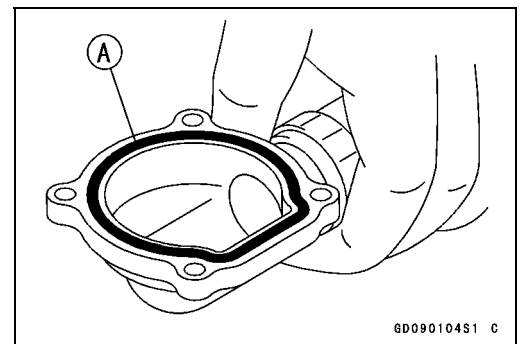

## 4-20 COOLING SYSTEM

### Thermostat

- Align the line [A] of thermostat housing cover and white mark [B] of water hose.
- Install the bracket [C] as shown.
- Tighten the thermostat housing cover bolts.

**Torque - Thermostat Housing Cover Bolts: 5.9 N·m (0.60 kgf·m, 52 in·lb)**

- Fill the radiator with coolant (see Coolant Change in the Periodic Maintenance chapter).

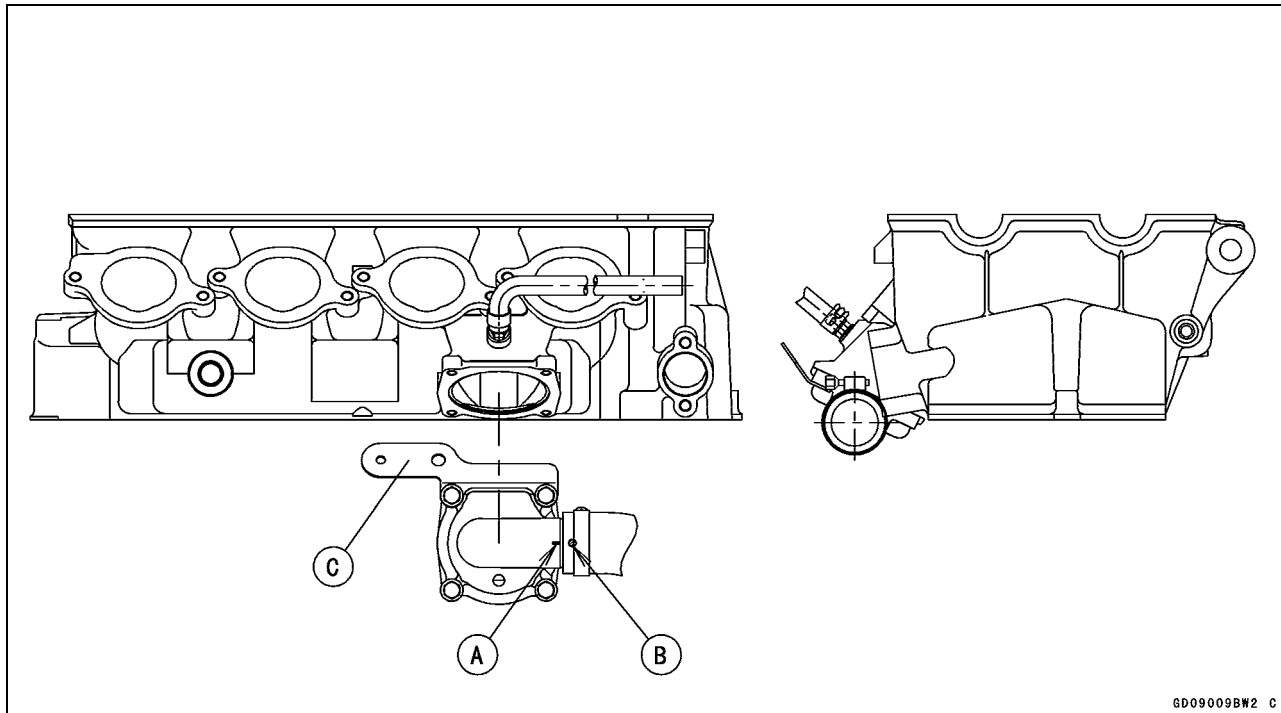

### *Thermostat Inspection*

- Remove the thermostat (see Thermostat Removal in this chapter), and inspect the thermostat valve [A] at room temperature.
- ★ If the valve is open, replace the thermostat with a new one.

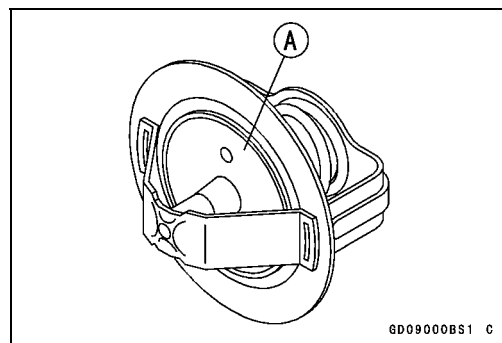

## Thermostat

- To check valve opening temperature, suspend the thermostat [A] in a container of water and raise the temperature of the water.
- The thermostat must be completely submerged and must not touch the container sides or bottom. Suspend an accurate thermometer [B] in the water so that the heat sensitive portions [C] are located in almost the same depth. It must not touch the container, either.
- ★ If the measurement is out of the specified range, replace the thermostat with a new one.

### Thermostat Valve Opening Temperature

58 ~ 62°C (136 ~ 144°F)

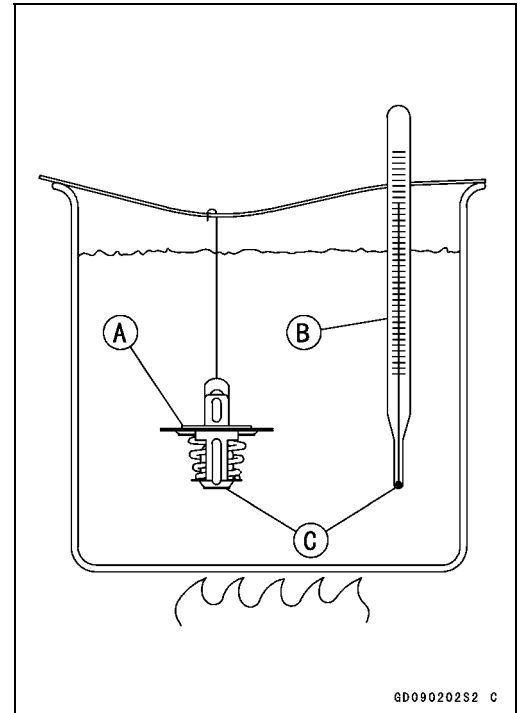

GD090202S2 C

## 4-22 COOLING SYSTEM

### Hoses and Pipes

#### *Hose Installation*

- Install the hoses and pipes, being careful to follow bending direction. Avoid sharp bending, kinking, flattening or twisting.
- Run the hoses in accordance with the Cable, Wire, and Hose Routing section in the Appendix chapter.
- Install the clamp [A] as near as possible to the hose end to clear the raised rib of the fitting. This will prevent the hoses from working loose.
- The clamp screws should be positioned correctly to prevent the clamps from contacting the other parts.

**Torque - Water Hose Clamp Screws: 2.0 N·m (0.20 kgf·m, 17 in·lb)**

#### *Hose Inspection*

- Refer to the Radiator Hose Damage and Installation Condition Inspection in the Periodic Maintenance chapter.

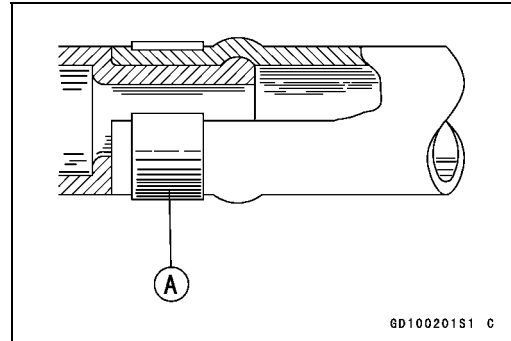

---

## Water Temperature Sensor

---

<b>CAUTION</b>
----------------

<p>The water temperature sensor should never be allowed to fall on a hard surface. Such a shock to their parts can damage them.</p>
---

### *Water Temperature Sensor Removal*

- Refer to the Water Temperature Sensor Removal in the Fuel System (DFI) chapter.  
Water Temperature Sensor [A]



### *Water Temperature Sensor Inspection*

- Refer to the Water Temperature Sensor Inspection in the Electrical System chapter.



# Engine Top End

## Table of Contents

Exploded View .....	5-2	Valve Clearance Inspection .....	5-23
Specifications .....	5-7	Valve Clearance Adjustment .....	5-23
Special Tools and Sealant .....	5-9	Valve Removal .....	5-23
Clean Air System .....	5-11	Valve Installation .....	5-23
Air Suction Valve Removal .....	5-11	Valve Guide Removal .....	5-23
Air Suction Valve Installation .....	5-11	Valve Guide Installation .....	5-24
Air Suction Valve Inspection .....	5-11	Valve-to-Guide Clearance	
Vacuum Switch Valve Removal ...	5-11	Measurement (Wobble	
Vacuum Switch Valve Installation	5-12	Method) .....	5-24
Vacuum Switch Valve Test .....	5-12	Valve Seat Inspection .....	5-25
Clean Air System Hose		Valve Seat Repair .....	5-25
Inspection .....	5-12	Cylinder, Pistons .....	5-30
Cylinder Head Cover .....	5-13	Cylinder Removal .....	5-30
Cylinder Head Cover Removal ...	5-13	Cylinder Installation .....	5-30
Cylinder Head Cover Installation .	5-13	Piston Removal .....	5-31
Camshaft Chain Tensioner .....	5-15	Piston Installation .....	5-31
Camshaft Chain Tensioner		Cylinder Wear .....	5-32
Removal .....	5-15	Piston Wear .....	5-32
Camshaft Chain Tensioner		Piston Ring, Piston Ring Groove	
Installation .....	5-15	Wear .....	5-33
Camshaft, Camshaft Chain .....	5-16	Piston Ring Groove Width .....	5-33
Camshaft Removal .....	5-16	Piston Ring Thickness .....	5-33
Camshaft Installation .....	5-16	Piston Ring End Gap .....	5-34
Camshaft, Camshaft Cap Wear ...	5-18	Throttle Body Holder .....	5-35
Camshaft Runout .....	5-18	Throttle Body Holder Installation ..	5-35
Cam Wear .....	5-19	Muffler .....	5-36
Camshaft Chain Removal .....	5-19	Muffler Body Removal .....	5-36
Cylinder Head .....	5-20	Muffler Body Installation .....	5-38
Cylinder Compression		Exhaust Pipe Removal .....	5-39
Measurement .....	5-20	Exhaust Pipe Installation .....	5-40
Cylinder Head Removal .....	5-21	Exhaust Butterfly Valve Cable	
Cylinder Head Installation .....	5-21	Removal .....	5-41
Cylinder Head Warp .....	5-22	Exhaust Butterfly Valve Cable	
Valves .....	5-23	Installation .....	5-41

# 5-2 ENGINE TOP END

## Exploded View

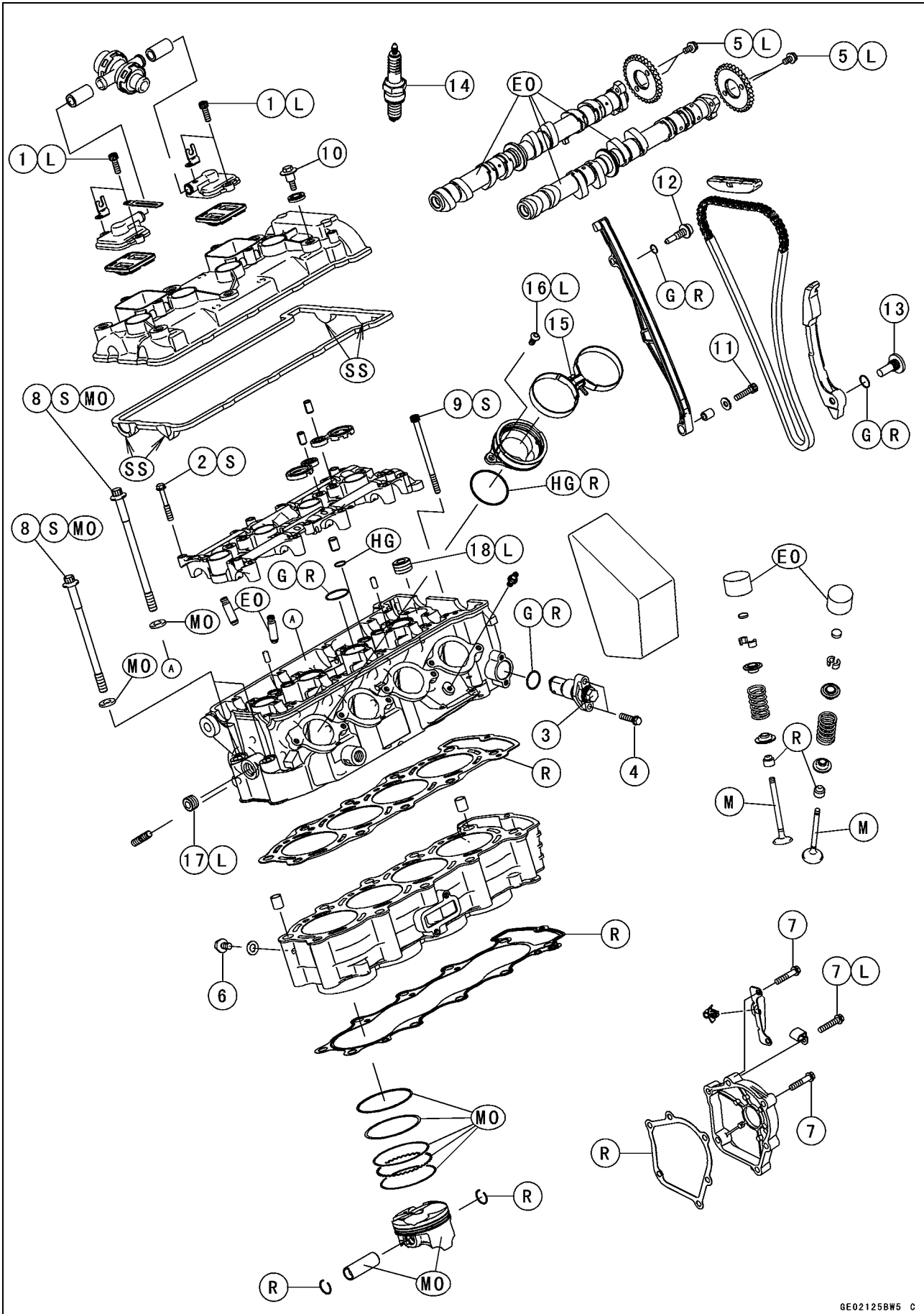

## Exploded View

No.	Fastener	Torque			Remarks
		N·m	kgf·m	ft·lb	
1	Air Suction Valve Cover Bolts	12	1.2	104 in·lb	L
2	Camshaft Cap Bolts	12	1.2	104 in·lb	S
3	Camshaft Chain Tensioner Cap Bolt	20	2.0	15	
4	Camshaft Chain Tensioner Mounting Bolts	11	1.1	97 in·lb	
5	Cam Sprocket Mounting Bolts	15	1.5	11	L
6	Coolant Drain Bolt (Cylinder)	9.8	1.0	87 in·lb	
7	Crankshaft Sensor Cover Bolts	9.8	1.0	87 in·lb	L (1)
8	Cylinder Head Bolts (M9)	39	4.0	29	MO, S
9	Cylinder Head Bolts (M6)	12	1.2	104 in·lb	S
10	Cylinder Head Cover Bolts	9.8	1.0	87 in·lb	
11	Front Camshaft Chain Guide Bolt (Lower)	12	1.2	104 in·lb	
12	Front Camshaft Chain Guide Bolt (Upper)	25	2.5	18	
13	Rear Camshaft Chain Guide Bolt	25	2.5	18	
14	Spark Plugs	13	1.3	113 in·lb	
15	Throttle Body Assy Holder Clamp Bolts	2.9	0.30	26 in·lb	
16	Throttle Body Holder Bolts	12	1.2	104 in·lb	L
17	Water Passage Plug (Left)	20	2.0	15	L
18	Water Passage Plugs (Upper)	20	2.0	15	L

EO: Apply engine oil.

G: Apply grease.

HG: Apply high-temperature grease.

L: Apply a non-permanent locking agent.

M: Apply molybdenum disulfide grease.

MO: Apply molybdenum disulfide oil solution.

(mixture of the engine oil and molybdenum disulfide grease in a weight ratio 10 : 1)

R: Replacement Parts

S: Follow the specific tightening sequence.

SS: Apply silicone sealant.

# 5-4 ENGINE TOP END

## Exploded View

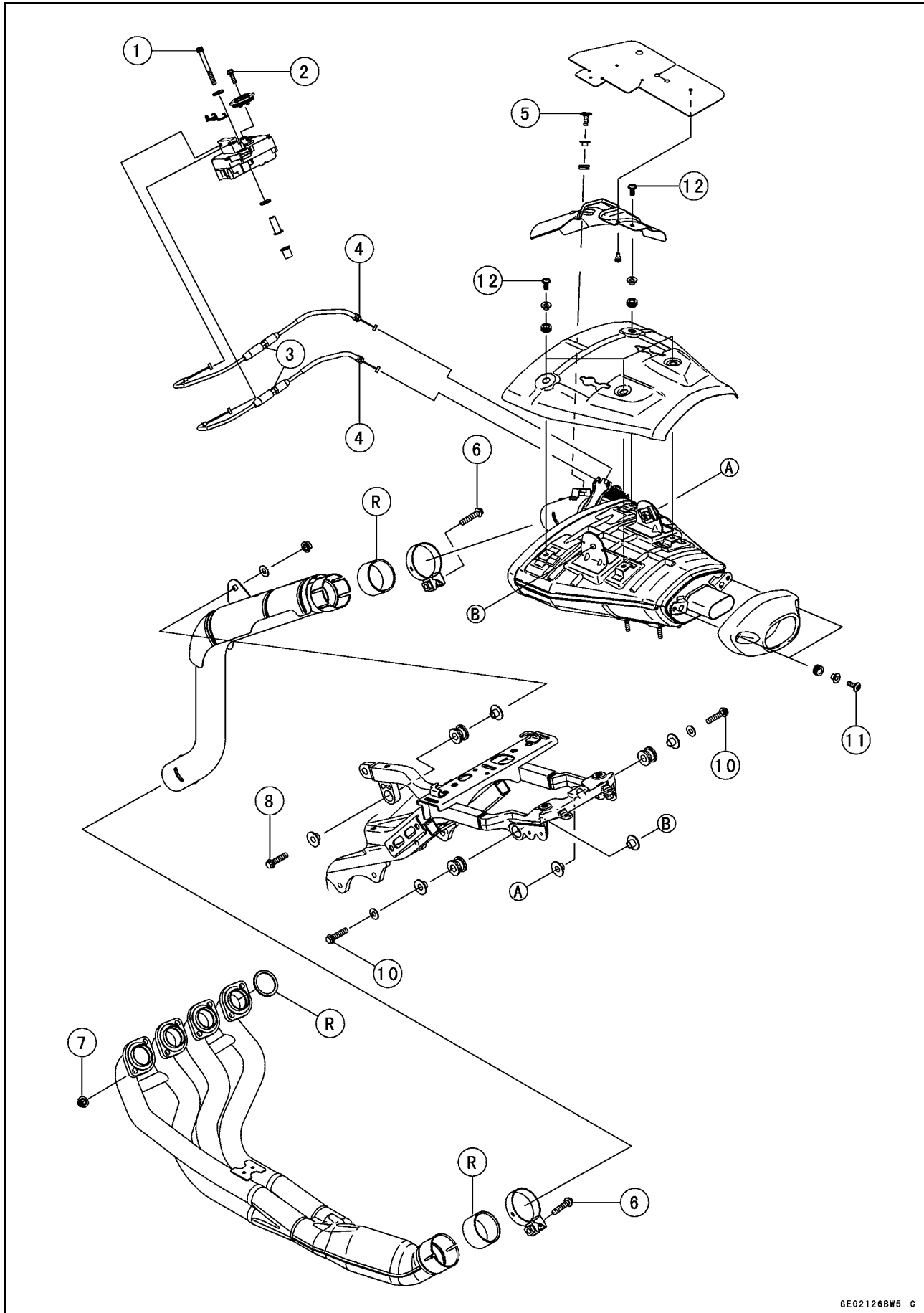

**Exploded View**

No.	Fastener	Torque			Remarks
		N·m	kgf·m	ft·lb	
1	Exhaust Butterfly Valve Actuator Mounting Bolts	6.9	0.70	61 in·lb	
2	Exhaust Butterfly Valve Actuator Pulley Bolt	4.9	0.50	43 in·lb	
3	Exhaust Butterfly Valve Cable Adjuster Locknuts	6.9	0.70	61 in·lb	
4	Exhaust Butterfly Valve Cable Locknuts	6.9	0.70	61 in·lb	
5	Exhaust Butterfly Valve Cover Bolt	6.9	0.70	61 in·lb	
6	Exhaust Pipe Clamp Bolt	17	1.7	12	
7	Exhaust Pipe Manifold Holder Nuts	17	1.7	12	
8	Exhaust Pipe Mounting Bolt	25	2.5	18	
9	Muffler Body Clamp Bolt	17	1.7	12	
10	Muffler Body Mounting Bolts	25	2.5	18	
11	Muffler Rear Cover Bolts	6.9	0.70	61 in·lb	
12	Muffler Upper Cover Bolts	6.9	0.70	61 in·lb	

R: Replacement Parts

**Exhaust System**

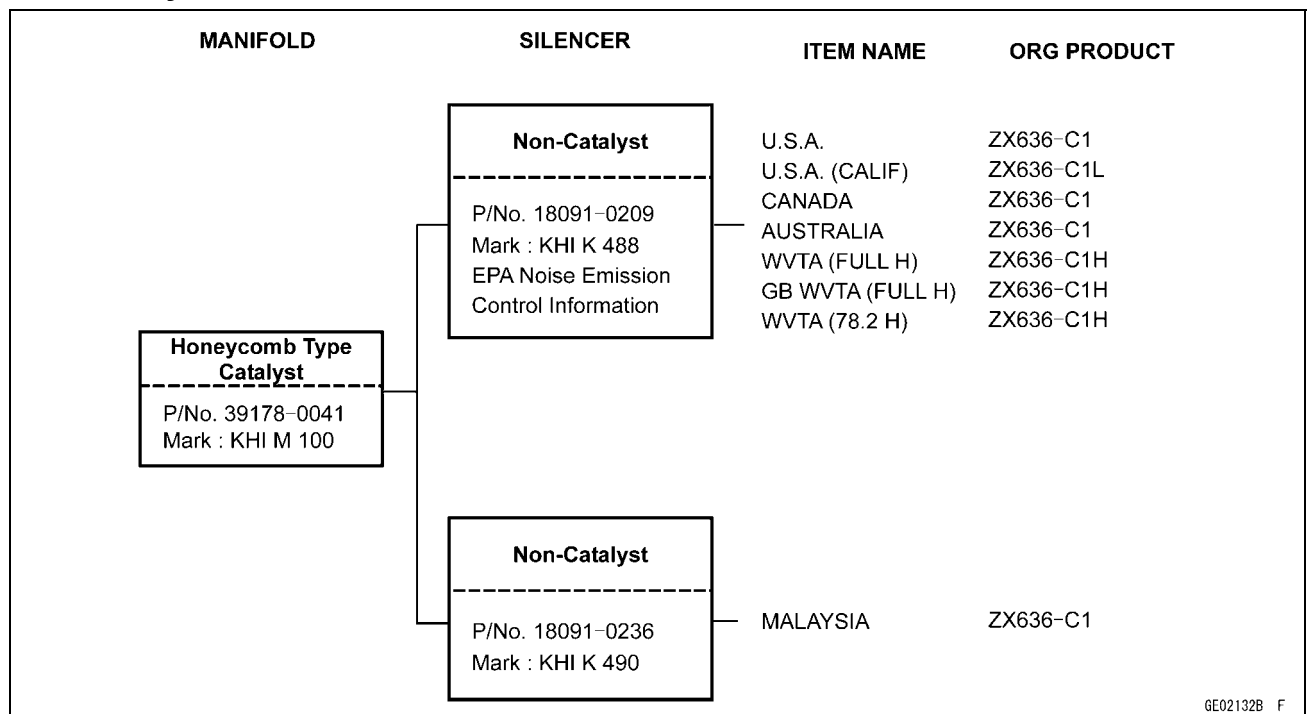

GE02132B F

- 78.2: Horsepower 78.2 kW (106.3 ps)
- Full: Full Power
- H: Honeycomb Type Catalyst
- WVTA: Whole Vehicle Type Approval
- GB: United Kingdom Model

## 5-6 ENGINE TOP END

### Exploded View

---

Manifold Mark Position [A]

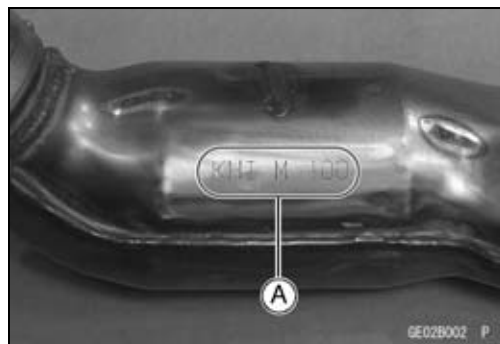

Silencer Mark Position [A]



## Specifications

Item	Standard	Service Limit
<b>Clean Air System</b>		
Vacuum Switch Valve Closing Pressure	Open → Close 41 ~ 49 kPa (310 ~ 370 mmHg)	---
<b>Camshafts</b>		
Cam Height:		
Exhaust	33.146 ~ 33.254 mm (1.3050 ~ 1.3092 in.)	33.05 mm (1.301 in.)
Inlet	34.146 ~ 34.254 mm (1.3443 ~ 1.3486 in.)	34.05 mm (1.341 in.)
Camshaft Journal, Camshaft Cap Clearance	0.038 ~ 0.081 mm (0.0015 ~ 0.0032 in.)	0.17 mm (0.0067 in.)
Camshaft Journal Diameter	23.940 ~ 23.962 mm (0.9425 ~ 0.9434 in.)	23.91 mm (0.941 in.)
Camshaft Bearing Inside Diameter	24.000 ~ 24.021 mm (0.9449 ~ 0.9457 in.)	24.08 mm (0.948 in.)
Camshaft Runout	TIR 0.02 mm (0.0008 in.) or less	TIR 0.1 mm (0.004 in.)
<b>Cylinder Head</b>		
Cylinder Compression	(Usable Range) 1 085 ~ 1 550 kPa (11.0 ~ 15.8 kgf/cm <sup>2</sup> , 156 ~ 225 psi) @350 r/min (rpm)	---
Cylinder Head Warp	---	0.05 mm (0.002 in.)
<b>Valves</b>		
Valve Clearance:		
Exhaust	0.22 ~ 0.31 mm (0.0087 ~ 0.0122 in.)	---
Inlet	0.11 ~ 0.19 mm (0.0047 ~ 0.0075 in.)	---
Valve Head Thickness:		
Exhaust	1.0 mm (0.039 in.)	0.5 mm (0.020 in.)
Inlet	0.5 mm (0.020 in.)	0.25 mm (0.001 in.)
Valve Stem Bend	TIR 0.01 mm (0.0004 in.) or less	TIR 0.05 mm (0.002 in.)
Valve Stem Diameter:		
Exhaust	3.955 ~ 3.970 mm (0.1557 ~ 0.1563 in.)	3.94 mm (0.155 in.)
Inlet	3.975 ~ 3.990 mm (0.1565 ~ 0.1571 in.)	3.96 mm (0.156 in.)
Valve Guide Inside Diameter:		
Exhaust	4.000 ~ 4.012 mm (0.1575 ~ 0.1580 in.)	4.08 mm (0.161 in.)
Inlet	4.000 ~ 4.012 mm (0.1575 ~ 0.1580 in.)	4.08 mm (0.161 in.)
Valve/Valve Guide Clearance (Wobble Method):		
Exhaust	0.09 ~ 0.16 mm (0.0035 ~ 0.0063 in.)	0.40 mm (0.016 in.)
Inlet	0.03 ~ 0.11 mm (0.0012 ~ 0.0043 in.)	0.35 mm (0.014 in.)
Valve Seat Cutting Angle	32°, 45°, 60°	---
Valve Seating Surface:		
Width:		
Exhaust	0.6 ~ 1.0 mm (0.024 ~ 0.039 in.)	---
Inlet	0.8 ~ 1.2 mm (0.031 ~ 0.047 in.)	---
Outside Diameter:		
Exhaust	23.5 ~ 23.7 mm (0.925 ~ 0.933 in.)	---
Inlet	27.9 ~ 28.1 mm (1.098 ~ 1.106 in.)	---

## 5-8 ENGINE TOP END

### Specifications

Item	Standard	Service Limit
Valve Spring Free Length:		
Exhaust	39.39 mm (1.551 in.)	38.0 mm (1.496 in.)
Inlet	35.27 mm (1.389 in.)	33.9 mm (1.335 in.)
<b>Cylinder, Piston</b>		
Cylinder Inside Diameter	68.000 ~ 68.012 mm (2.677 ~ 2.678 in.)	68.10 mm (2.68 in.)
Piston Diameter	67.975 ~ 67.990 mm (2.676 ~ 2.679 in.)	67.53 mm (2.66 in.)
Piston/Cylinder Clearance	0.010 ~ 0.037 mm (0.0004 ~ 0.0016 in.)	— — —
Piston Ring/Groove Clearance:		
Top	0.03 ~ 0.07 mm (0.0012 ~ 0.0028 in.)	0.17 mm (0.0067 in.)
Second	0.03 ~ 0.07 mm (0.0012 ~ 0.0028 in.)	0.17 mm (0.0067 in.)
Piston Ring Groove Width:		
Top	0.82 ~ 0.84 mm (0.0323 ~ 0.0331 in.)	0.92 mm (0.036 in.)
Second	0.82 ~ 0.84 mm (0.0323 ~ 0.0331 in.)	0.92 mm (0.036 in.)
Piston Ring Thickness:		
Top	0.77 ~ 0.79 mm (0.0303 ~ 0.0311 in.)	0.70 mm (0.028 in.)
Second	0.77 ~ 0.79 mm (0.0303 ~ 0.0311 in.)	0.70 mm (0.028 in.)
Piston Ring End Gap:		
Top	0.12 ~ 0.22 mm (0.0047 ~ 0.0087 in.)	0.5 mm (0.020 in.)
Second	0.30 ~ 0.45 mm (0.0118 ~ 0.0177 in.)	0.8 mm (0.031 in.)

Special Tools and Sealant

Compression Gauge, 20 kgf/cm<sup>2</sup>:  
57001-221

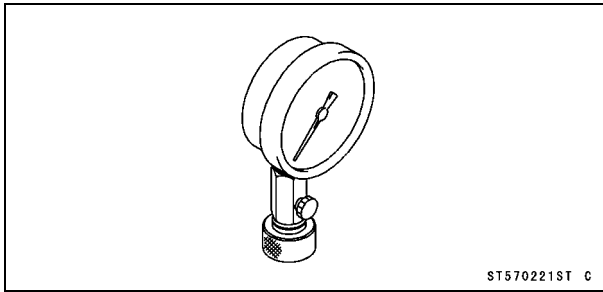

ST570221ST C

Valve Seat Cutter, 32° -  $\phi$ 25:  
57001-1118

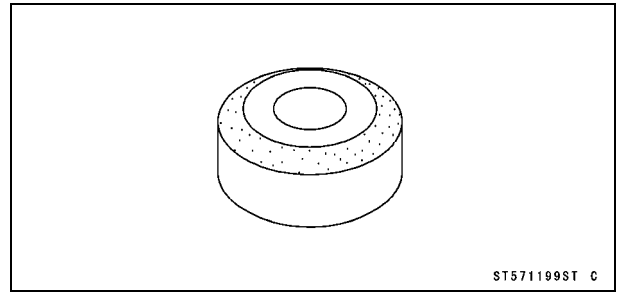

ST571199ST C

Valve Spring Compressor Assembly:  
57001-241

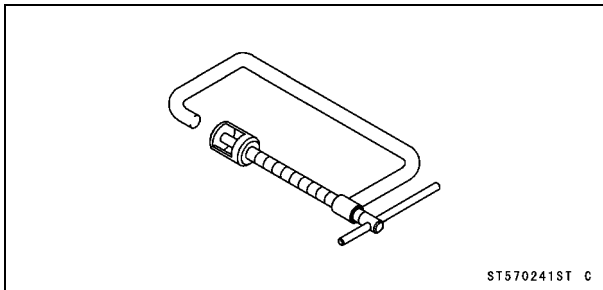

ST570241ST C

Valve Seat Cutter, 32° -  $\phi$ 28:  
57001-1119

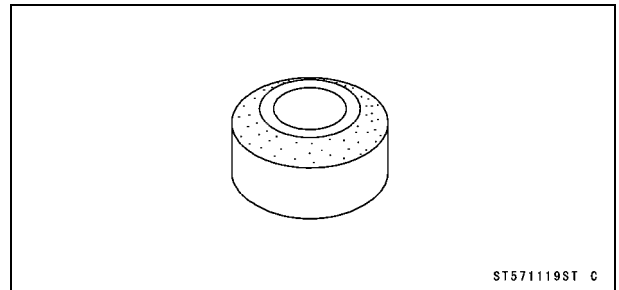

ST571119ST C

Piston Pin Puller Assembly:  
57001-910

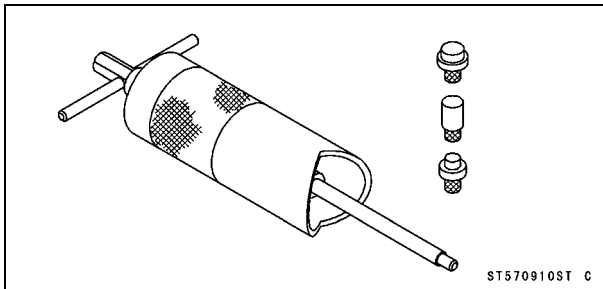

ST570910ST C

Valve Seat Cutter Holder Bar:  
57001-1128

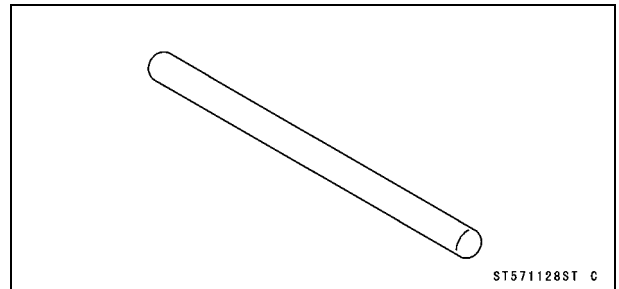

ST571128ST C

Valve Seat Cutter, 45° -  $\phi$ 24.5:  
57001-1113

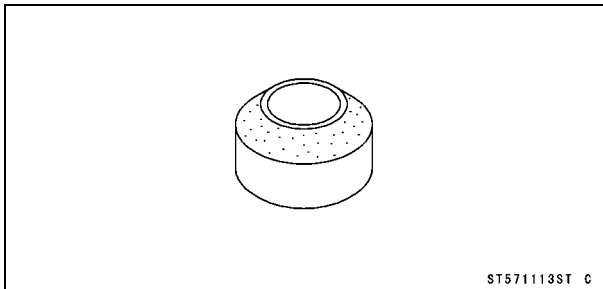

ST571113ST C

Valve Spring Compressor Adapter,  $\phi$ 21:  
57001-1272

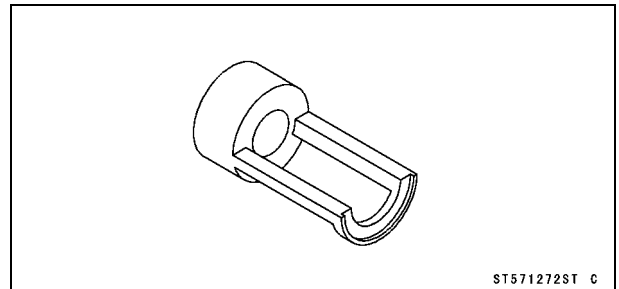

ST571272ST C

Valve Seat Cutter, 45° -  $\phi$ 27.5:  
57001-1114

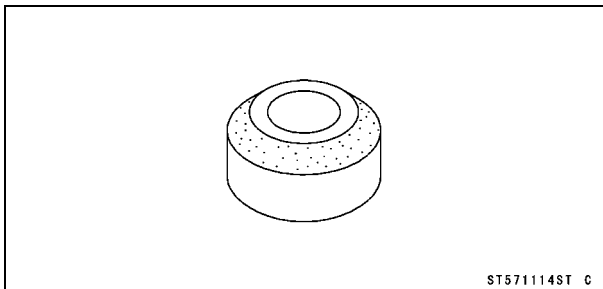

ST571114ST C

Valve Guide Arbor,  $\phi$ 4:  
57001-1273

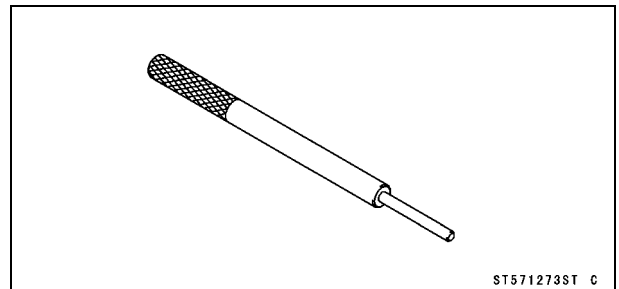

ST571273ST C

# 5-10 ENGINE TOP END

## Special Tools and Sealant

Valve Guide Reamer,  $\phi 4$ :  
57001-1274

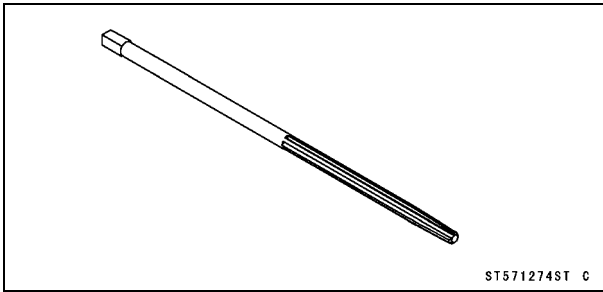

Valve Guide Driver:  
57001-1564

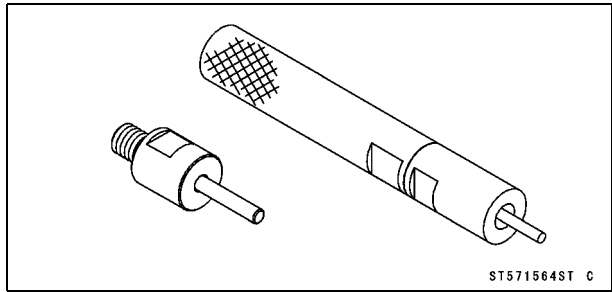

Valve Seat Cutter Holder,  $\phi 4$ :  
57001-1275

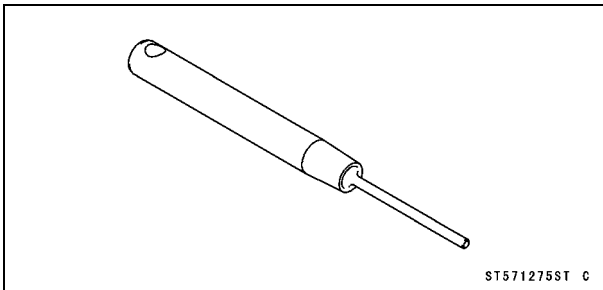

Compression Gauge Adapter, M10 x 1.0:  
57001-1601

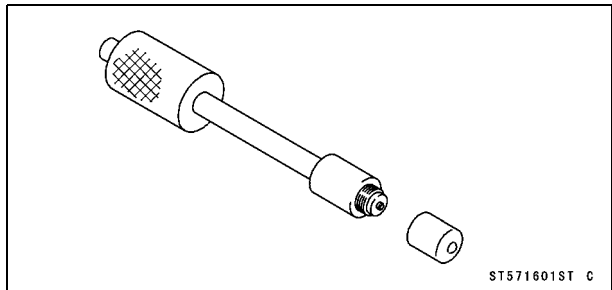

Fork Oil Level Gauge:  
57001-1290

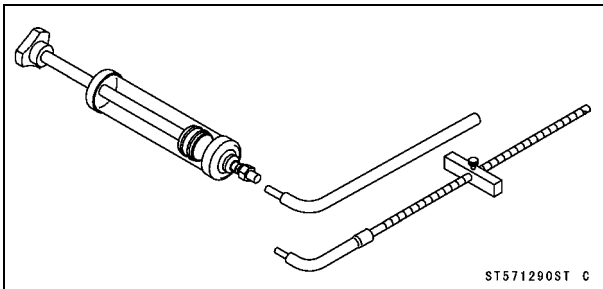

L-Shape Hose:  
57001-1606

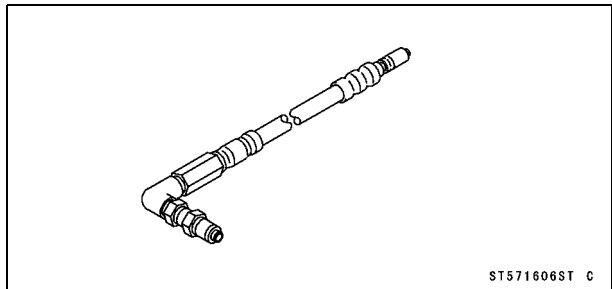

Valve Seat Cutter, 60° -  $\phi 25$ :  
57001-1328

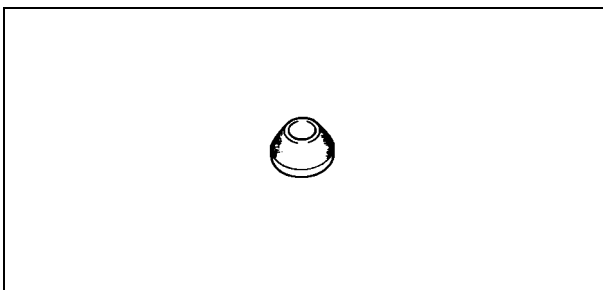

Attachment C:  
57001-1624

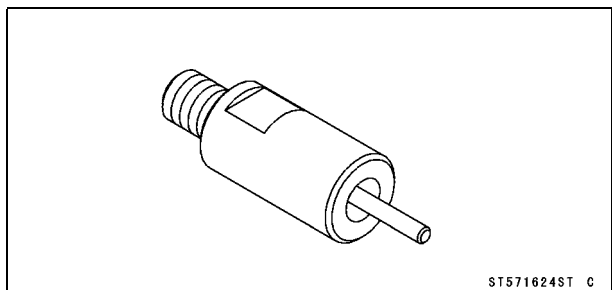

Valve Seat Cutter, 60° -  $\phi 27$ :  
57001-1409

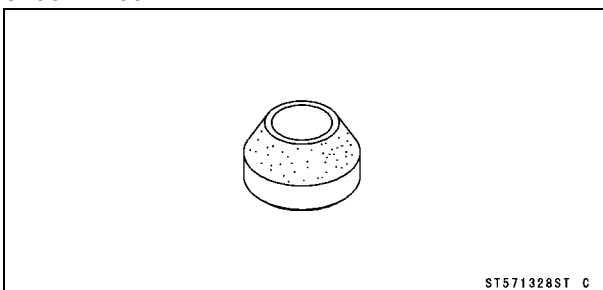

Kawasaki Bond (Silicone Sealant):  
92104-0004

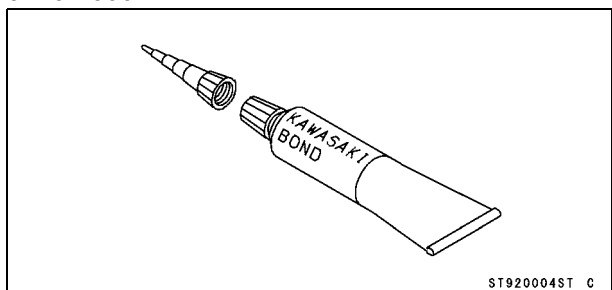

## Clean Air System

### *Air Suction Valve Removal*

- Remove:
  - Fuel Tank (see Fuel Tank Removal in the Fuel System (DFI) chapter)
  - Air Cleaner Housing (see Air Cleaner Housing Removal in the Fuel System (DFI) chapter)
- Separate the hoses [A] from the air suction valve cover.
- Remove:
  - Air Suction Valve Cover Bolts [B]
  - Air Suction Valve Cover [C]
  - Air Suction Valve

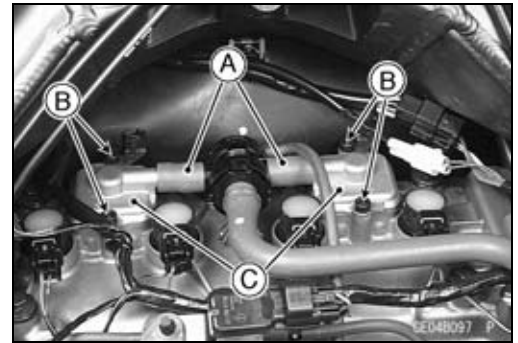

### *Air Suction Valve Installation*

- Install the air suction valve so that opening [A] of the reeds faces the rear and downward.

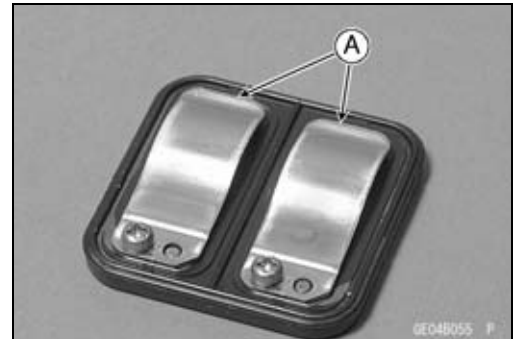

- Install the clamps [A] as shown.
- Apply a non-permanent locking agent to the threads of the air suction valve cover bolts, and tighten them with the specified torque.

**Torque - Air Suction Valve Cover Bolts: 12 N·m (1.2 kgf·m, 104 in·lb)**

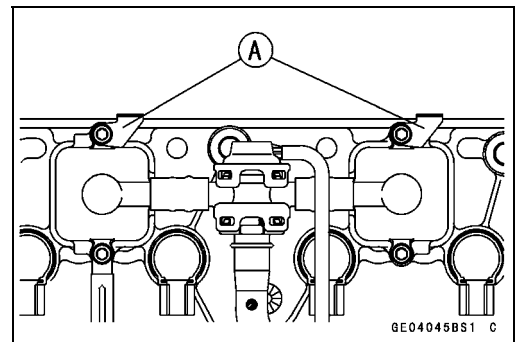

### *Air Suction Valve Inspection*

- Refer to the Air Suction Valve Inspection in the Periodic Maintenance chapter.

### *Vacuum Switch Valve Removal*

- Remove:
  - Fuel Tank (see Fuel Tank Removal in the Fuel System (DFI) chapter)
  - Air Cleaner Housing (see Air Cleaner Housing Removal in the Fuel System (DFI) chapter)
- Remove the throttle body assembly hose [A], clamp [B] and hoses [C].

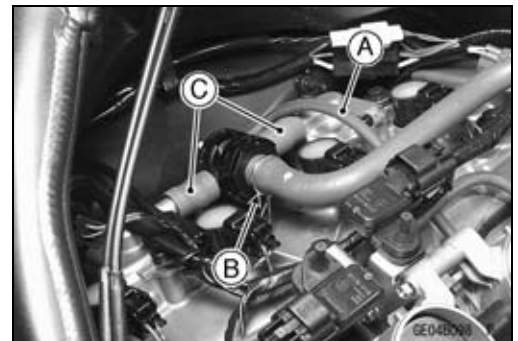

## 5-12 ENGINE TOP END

### Clean Air System

#### Vacuum Switch Valve Installation

- Install the vacuum switch valve so that the air duct [A] faces right side.
- Route the hoses correctly (see Cable, Wire, and Hose Routing section in the Appendix chapter).

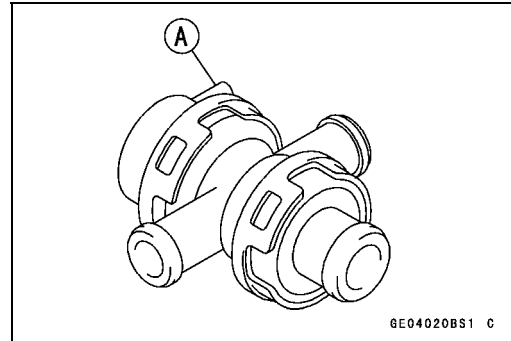

#### Vacuum Switch Valve Test

- Remove:  
Vacuum Switch Valve (see Vacuum Switch Valve Removal in this chapter)
- Connect a vacuum gauge [A] and syringe [B] or fork oil level gauge to the vacuum hoses as shown.

**Special Tool - Fork Oil Level Gauge: 57001-1290**  
Air Flow [C]

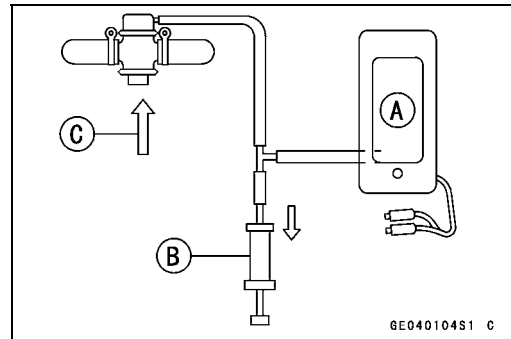

- Gradually raise the vacuum (lower the pressure) applied to the vacuum switch valve, and check the valve operation. When the vacuum is low, the vacuum switch valve should permit air to flow. When the vacuum raises to valve closing pressure, it should stop air flow.  
Spring [A]  
Diaphragm [B]  
Valve [C]  
Low Vacuum [D]  
Secondary Air Flow [E]

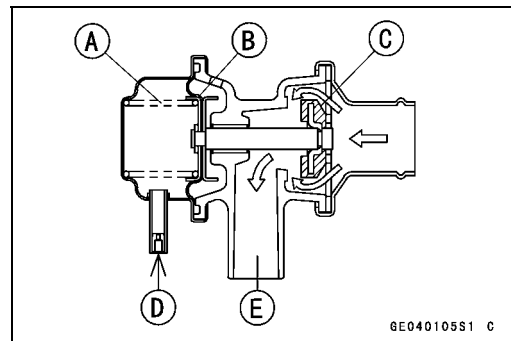

- ★ If the vacuum switch valve does not operate as described, replace it with a new one.

#### NOTE

○ To check air flow through the vacuum switch valve, just blow through the air cleaner hose.

#### Vacuum Switch Valve Closing Pressure (Open → Close)

Standard: 41 ~ 49 kPa (310 ~ 370 mmHg)

High Vacuum [A]

Secondary air cannot flow [B]

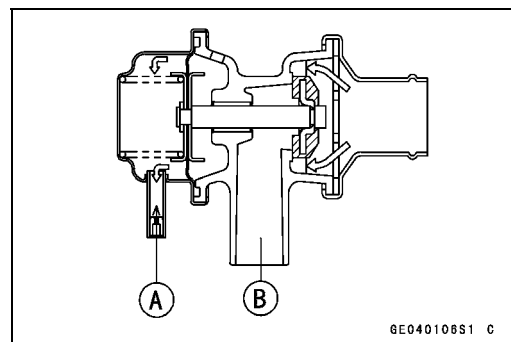

#### Clean Air System Hose Inspection

- Be certain that all the hoses are routed without being flattened or kinked, and are connected correctly to the air cleaner housing, throttle body, vacuum switch valve and air suction valve covers.
- ★ If they are not, correct them. Replace them if they are damaged.

## Cylinder Head Cover

### Cylinder Head Cover Removal

- Remove:
  - Fuel Tank (see Fuel Tank Removal in the Fuel System (DFI) chapter)
  - Air Cleaner Housing (see Air Cleaner Housing Removal in the Fuel System (DFI) chapter)
  - Throttle Body Assembly (see Throttle Body Assembly Removal in the Fuel System (DFI) chapter)
  - Vacuum Switch Valve [A] (see Vacuum Switch Valve Removal in this chapter)
- Free the heat insulation rubber plate.
- Remove:
  - Air Suction Valve Covers (see Air Suction Valve Removal in this chapter)
  - Stick Coils [A] (see Stick Coil (Ignition Coil together with Spark Plug Cap) Removal in the Electrical System chapter)
- Remove the cylinder head cover bolts [A].
- Remove the ground lead [B].

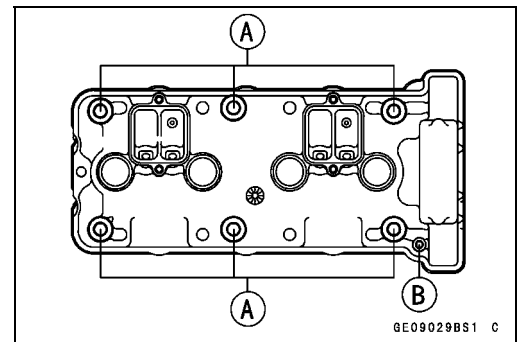

- Remove the cylinder head cover [A] to backward floating it a little up.

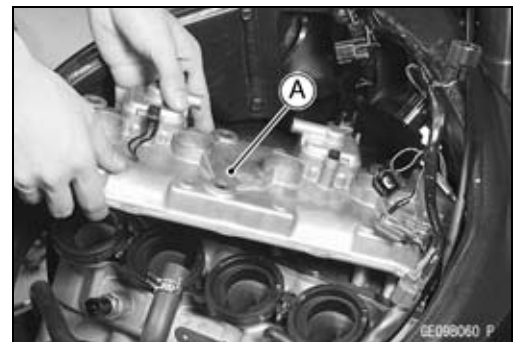

### Cylinder Head Cover Installation

- Replace the head cover gasket with a new one.
  - Apply silicone sealant [A] to the cylinder head as shown.
- Sealant - Kawasaki Bond (Silicone Sealant): 92104-0004**

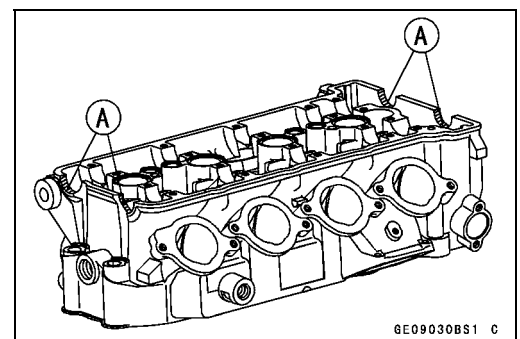

## 5-14 ENGINE TOP END

### Cylinder Head Cover

- Install:
  - Dowel Pins [A]
  - Plug Hole Gaskets [B]

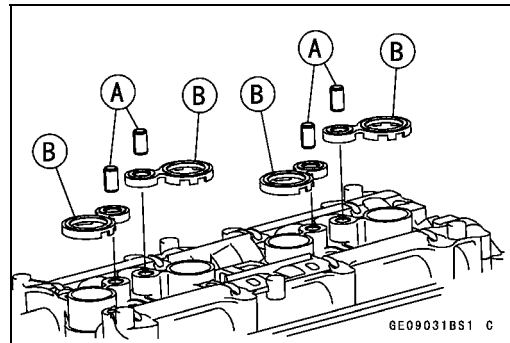

- Install the washer [A] with the metal side faces upward.

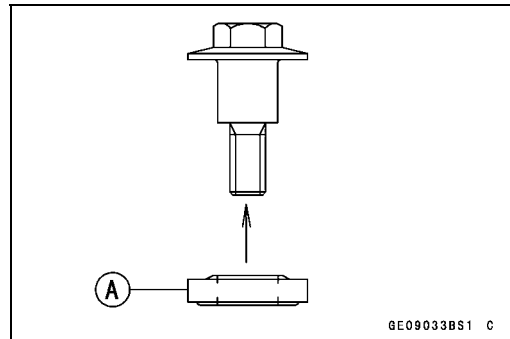

- Install the cylinder head cover.
- Tighten the cover bolts [A].
  - Torque - Cylinder Head Cover Bolts: 9.8 N·m (1.0 kgf·m, 87 in·lb)**
- Install the removed parts (see appropriate chapters).

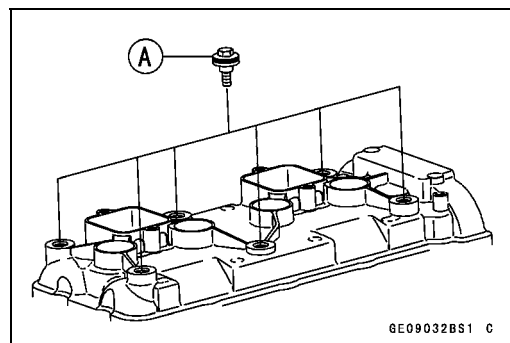

## Camshaft Chain Tensioner

### Camshaft Chain Tensioner Removal

#### CAUTION

This is a non-return type camshaft chain tensioner. The push rod does not return to its original position once it moves out to take up camshaft chain slack. Observe all the rules listed below:

When removing the tensioner, do not take out the mounting bolts only halfway. Retightening the mounting bolts from this position could damage the tensioner and the camshaft chain. Once the bolts are loosened, the tensioner must be removed and reset as described in "Camshaft Chain Tensioner Installation".

Do not turn over the crankshaft while the tensioner is removed. This could upset the camshaft chain timing, and damage the valves.

- Remove:
  - Fuel Tank (see Fuel Tank Removal in the Fuel System (DFI) chapter)
  - Throttle Body Assy (see Throttle Body Assy Removal in the Fuel System (DFI) chapter)
  - Cap Bolt [A]
  - Washer [B]
  - Spring [C]
  - Rod [D]
- Remove the mounting bolts [E] and take off the camshaft chain tensioner.

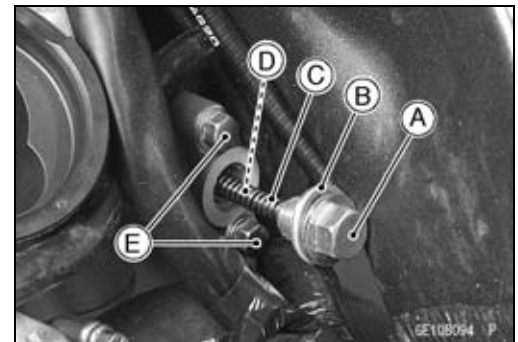

### Camshaft Chain Tensioner Installation

- Apply grease to the O-ring.
- Release the stopper [A] and push the push rod [B] into the interior of tensioner body [C].
- Install the tensioner body so that the stopper faces upward.

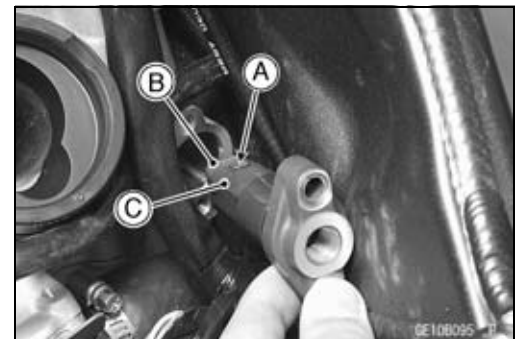

- Tighten the tensioner mounting bolts [A].
  - Torque - Camshaft Chain Tensioner Mounting Bolts: 11 N·m (1.1 kgf·m, 97 in·lb)**
- Install the rod, spring and washer.
- Tighten the cap bolt [B].
  - Torque - Camshaft Chain Tensioner Cap Bolt: 20 N·m (2.0 kgf·m, 15 ft·lb)**
- Turn the crankshaft 2 turns clockwise to allow the tensioner to expand and recheck the camshaft chain timing.

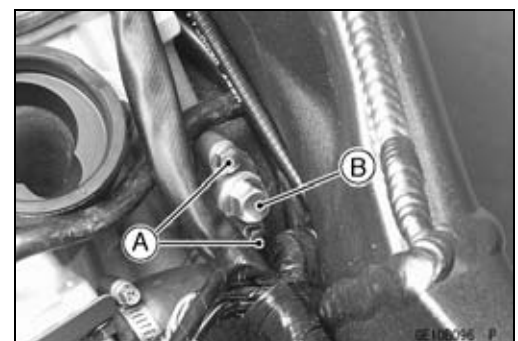

# 5-16 ENGINE TOP END

## Camshaft, Camshaft Chain

### Camshaft Removal

- Remove:
  - Cylinder Head Cover (see Cylinder Head Cover Removal in this chapter)
  - Crankshaft Sensor Cover (see Crankshaft Sensor Removal in the Electrical System chapter)
- Position the crankshaft at #1, 4 piston TDC.
  - TDC mark [A] for #1, 4 Pistons
  - Timing Mark (Crankcase Halves Mating Surface) [B]

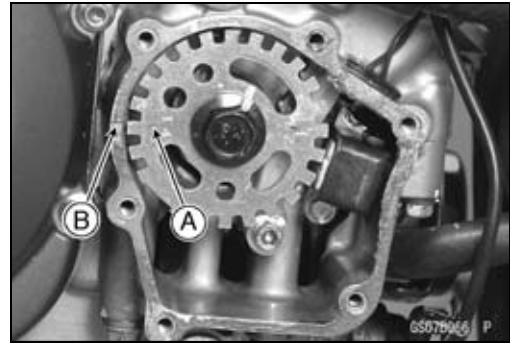

- Remove:
  - Camshaft Chain Tensioner (see Camshaft Chain Tensioner Removal in this chapter)
  - Plug Hole Gaskets and Cylinder Head Cover Gasket
  - Camshaft Cap Bolts [A]
  - Camshaft Cap [B]
  - Camshafts [C]
- Stuff a clean cloth into the chain tunnel to keep any parts from dropping into the crankcase.

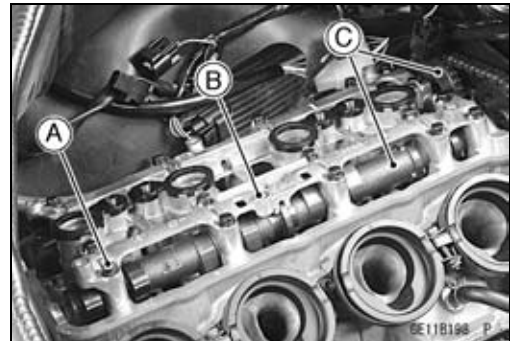

- Loosen the camshaft cap bolts as shown sequence in the figure.

<b>CAUTION</b>
<b>If camshaft cap bolt have not loosen with specified loosening sequence, the valve spring force could deform the camshaft cap and oil line boss.</b>

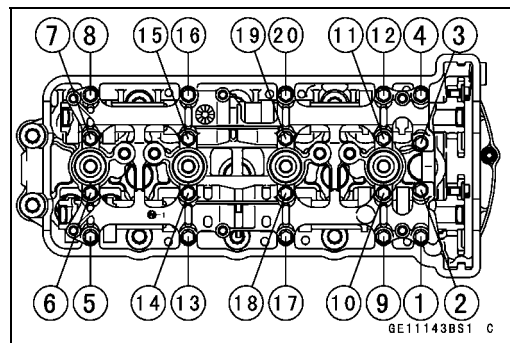

- Remove the cam sprocket mounting bolts [A].
- Remove the cam sprocket.

<b>CAUTION</b>
<b>The crankshaft may be turned while the camshafts are removed. Always pull the chain taut while turning the crankshaft. This avoids kinking the chain on the lower (crankshaft) sprocket. A kinked chain could damage both the chain and the sprocket.</b>

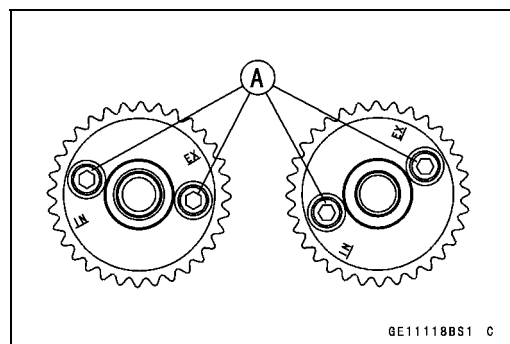

### Camshaft Installation

- Be sure to install the following parts.
  - O-rings [A]
  - O-rings [B]
  - Dowel Pins [C]

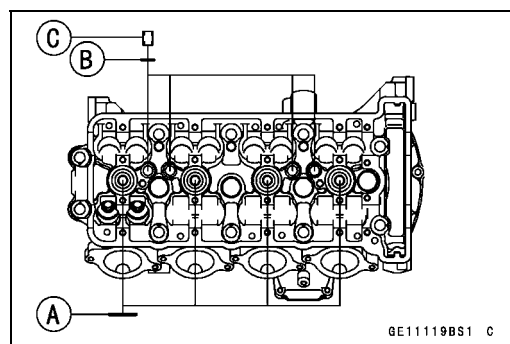

## Camshaft, Camshaft Chain

- Install the cam sprockets as shown in figure.
  - #4 Cam Positions [A]
  - Inlet Cam Sprocket [B]
  - Exhaust Cam Sprocket [C]
- Apply a non-permanent locking agent to the threads and tighten the bolts.
 

**Torque - Cam Sprocket Mounting Bolts: 15 N·m (1.5 kgf·m, 11 ft·lb)**

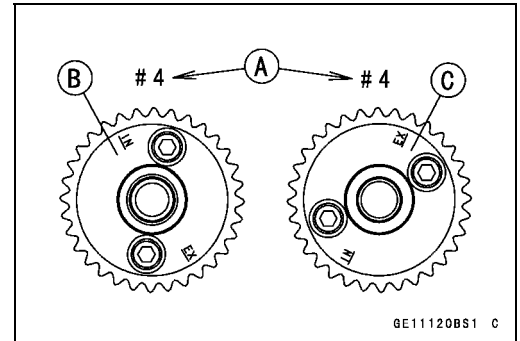

- Apply engine oil to all cam parts and journals.
- If a new camshaft is to be used, apply a thin coat of molybdenum disulfide grease to the cam surfaces.

### NOTE

○The exhaust camshaft has a 161 EX mark [A] and the inlet camshaft has a 161 IN mark [B]. Be careful not to mix up these shafts.

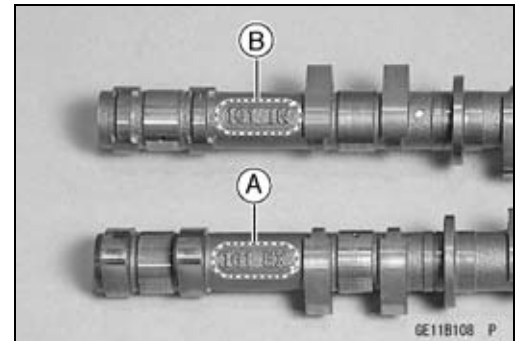

- Position the crankshaft at #1, 4 piston TDC.
  - Pull the tension side (exhaust side) [A] of the chain taut to install the chain.
  - Engage the camshaft chain with the camshaft sprockets so that the timing marks on the sprockets are positioned as shown.
    - The timing marks of #1, 4 must be aligned with the lower surface of crankcase of rear side [B].
    - The timing marks must be aligned with the cylinder head upper surface [C].
- EX Mark [D]  
IN Mark [E]  
1st Pin [F]  
2nd Pin [G]  
3rd Pin [H]  
28th Pin [I]

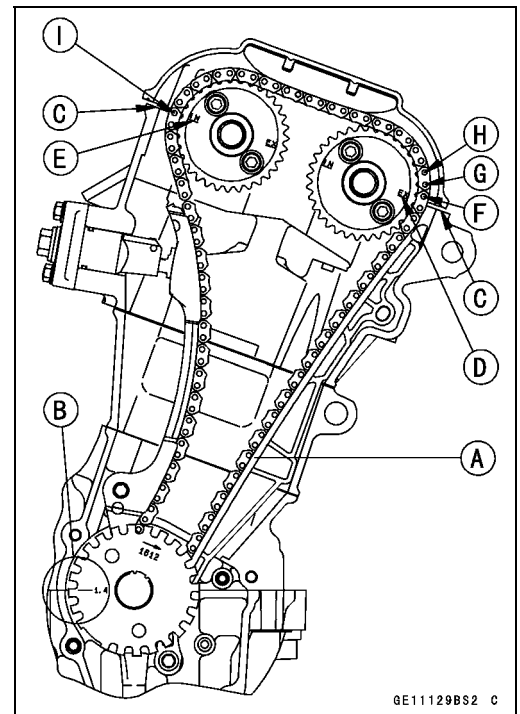

- Install the camshaft cap.
  - First tighten the camshaft cap bolts evenly to seat the camshaft in place, then tighten all bolts following the specified tightening sequence.
    - First Round [1 ~ 20]
    - Second Round [1 ~ 16]
    - Final Tightening: [1 ~ 20]

### Torque - Camshaft Cap Bolts:

**First, Second: 5.9 N·m (0.60 kgf·m, 52 in·lb)**  
**Final: 12 N·m (1.2 kgf·m, 104 in·lb)**

- Install the camshaft chain tensioner (see Camshaft Chain Tensioner Installation in this chapter).
- Install the removed parts (see appropriate chapters).

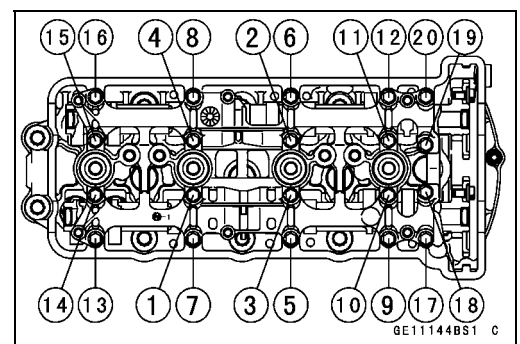

## 5-18 ENGINE TOP END

### Camshaft, Camshaft Chain

#### Camshaft, Camshaft Cap Wear

- Remove:
  - Camshaft Cap (see Camshaft Removal in this chapter)
- Cut strips of plastigage to journal width. Place a strip on each journal parallel to the camshaft installed in the correct position.
- Measure each clearance between the camshaft journal and the camshaft cap using plastigage (press gauge) [A].

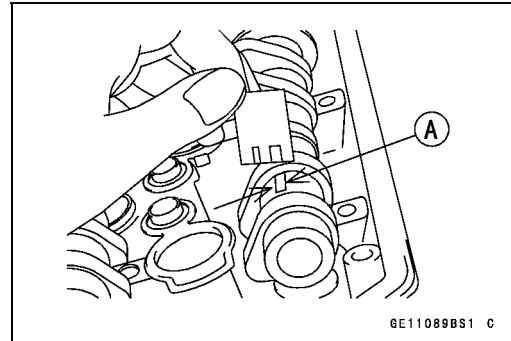

- Tighten:
  - Torque - Camshaft Cap Bolts: 12 N·m (1.2 kgf·m, 104 in·lb)**

#### NOTE

○ Do not turn the camshaft when the plastigage is between the journal and camshaft cap.

#### Camshaft Journal, Camshaft Cap Clearance

**Standard: 0.038 ~ 0.081 mm (0.0015 ~ 0.0032 in.)**

**Service Limit: 0.17 mm (0.0067 in.)**

- ★ If any clearance exceeds the service limit, measure the diameter of each camshaft journal with a micrometer.

#### Camshaft Journal Diameter

**Standard: 23.940 ~ 23.962 mm (0.9425 ~ 0.9434 in.)**

**Service Limit: 23.91 mm (0.941 in.)**

- ★ If the camshaft journal diameter is less than the service limit, replace the camshaft with a new one and measure the clearance again.
- ★ If the clearance still remains out of the limit, replace the cylinder head unit.

#### Camshaft Runout

- Remove the camshaft (see Camshaft Removal in this chapter).
- Set the camshaft in a camshaft alignment jig or on V blocks.
- Measure runout with a dial gauge at the specified place as shown.
- ★ If the runout exceeds the service limit, replace the shaft.

#### Camshaft Runout

**Standard: TIR 0.02 mm (0.0008 in.) or less**

**Service Limit: TIR 0.1 mm (0.004 in.)**

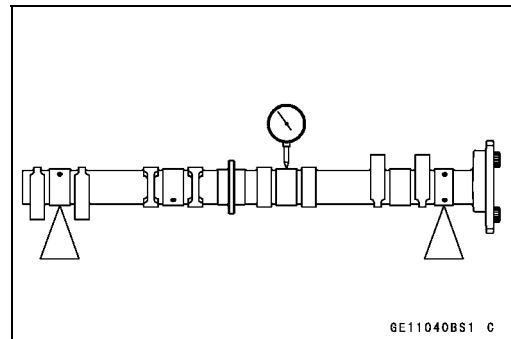

## Camshaft, Camshaft Chain

### Cam Wear

- Remove the camshaft (see Camshaft Removal in this chapter).
- Measure the height [A] of each cam with a micrometer.
- ★ If the cams are worn down past the service limit, replace the camshaft.

### Cam Height

#### Standard:

**Exhaust** 33.146 ~ 33.254 mm (1.3050 ~ 1.3092 in.)

**Inlet** 34.146 ~ 34.254 mm (1.3443 ~ 1.3486 in.)

#### Service Limit:

**Exhaust** 33.05 mm (1.301 in.)

**Inlet** 34.05 mm (1.341 in.)

### Camshaft Chain Removal

- Split the crankcase (see Crankcase Splitting in the Crankshaft/Transmission chapter).
- Remove the camshaft chain [A] from the crankshaft sprocket.

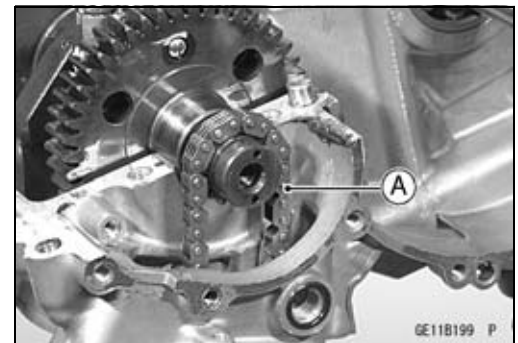
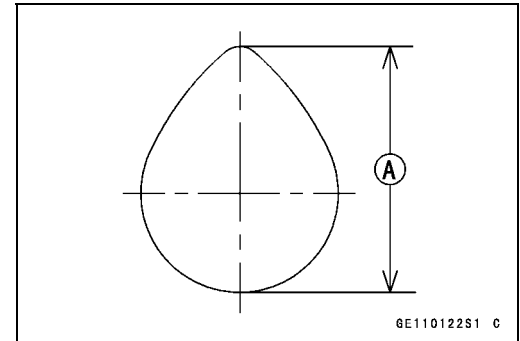

## 5-20 ENGINE TOP END

### Cylinder Head

#### Cylinder Compression Measurement

##### NOTE

○ Use the battery which is fully charged.

- Warm up the engine thoroughly.
- Stop the engine.
- Remove:
  - Fuel Tank (see Fuel Tank Removal in the Fuel System (DFI) chapter)
  - Air Cleaner Housing (see Air Cleaner Housing Removal in the Fuel System (DFI) chapter)
  - Stick Coils (see Stick Coil (Ignition Coil together with Spark Plug Cap) Removal in the Electrical System chapter)
  - Spark Plugs (see Spark Plug Removal in the Electrical System chapter)
- Attach the compression gauge [A] and adapter [B] firmly into the spark plug hole.
- Using the starter motor, turn the engine over with the throttle fully open until the compression gauge stops rising; the compression is the highest reading obtainable.

**Special Tools - Compression Gauge, 20 kgf/cm<sup>2</sup> [A]: 57001-221**

**Compression Gauge Adapter, M10 × 1.0 [B]: 57001-1601**

**L-Shape Hose [C]: 57001-1606**

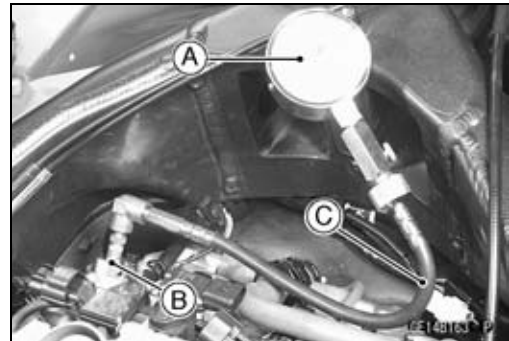

#### Cylinder Compression

**Usable Range: 1 085 ~ 1 550 kPa (11.0 ~ 15.8 kgf/cm<sup>2</sup>, 156 ~ 225 psi) @350 r/min (rpm)**

- Repeat the measurement for the other cylinders.
- Install the spark plugs.

**Torque - Spark Plugs: 13 N·m (1.3 kgf·m, 113 in·lb)**

○ The following table should be consulted if the obtainable compression reading is not within the usable range.

Problem	Diagnosis	Remedy (Action)
Cylinder compression is higher than usable range	Carbon accumulation on piston and in combustion chamber possibly due to damaged valve stem oil seal and/or damaged piston oil rings (This may be indicated by white exhaust smoke).	Remove the carbon deposits and replace damaged parts if necessary.
	Incorrect cylinder head gasket thickness	Replace the gasket with a standard part.
Cylinder compression is lower than usable range	Gas leakage around cylinder head	Replace damaged check gasket and cylinder head warp.
	Bad condition of valve seating	Repair if necessary.
	Incorrect valve clearance	Adjust the valve clearance.
	Incorrect piston/cylinder clearance	Replace the piston and/or cylinder.
	Piston seizure	Inspect the cylinder and replace/repair the cylinder and/or piston as necessary.
	Bad condition of piston ring and/or piston ring grooves.	Replace the piston and/or the piston rings.

## Cylinder Head

### Cylinder Head Removal

- Drain the coolant (see Coolant Change in the Periodic Maintenance chapter).
- Remove:
  - Fuel Tank (see Fuel Tank Removal in the Fuel System (DFI) chapter)
  - Air Cleaner Housing (see Air Cleaner Housing Removal in the Fuel System (DFI) chapter)
  - Throttle Body Assembly (see Throttle Body Assembly Removal in the Fuel System (DFI) chapter)
  - Exhaust Pipe (see Exhaust Pipe Removal in this chapter)
  - Cylinder Head Cover (see Cylinder Head Cover Removal in this chapter)
  - Camshaft Position Sensor (see Camshaft Position Sensor Removal in the Electrical System chapter)
  - Camshafts (see Camshaft Removal in this chapter)
- Remove:
  - Front Camshaft Chain Guide Bolts [A]
  - Rear Camshaft Chain Guide Bolt [B]
  - Right and Left Upper Engine Mounting Bolts (see Engine Removal in the Engine Removal/Installation chapter)

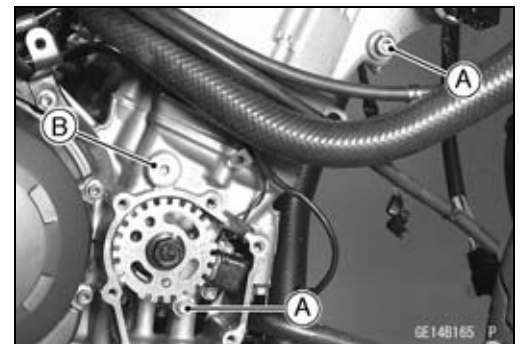

- Remove the M6 cylinder head bolt [A], and then the M9 cylinder head bolts [B].
- Take off the cylinder head forward.

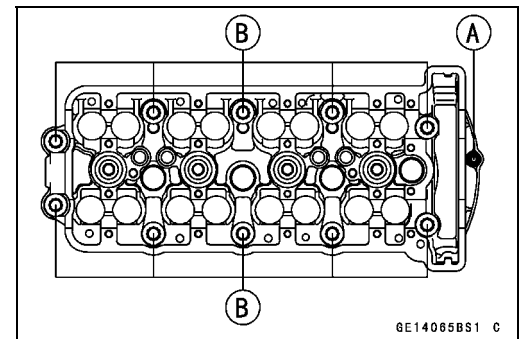

### Cylinder Head Installation

#### NOTE

○ The camshaft cap is machined with the cylinder head, so if a new cylinder head is installed, use the cap that is supplied with the new head.

- Install a new cylinder head gasket and dowel pins.
- Apply molybdenum disulfide oil solution to both sides [A] of the cylinder head bolt washers.

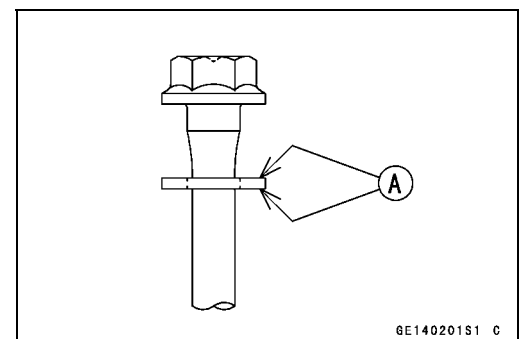

## 5-22 ENGINE TOP END

### Cylinder Head

- Tighten the M9 cylinder head bolts following the tightening sequence [1 ~ 10].  
148 mm (5.83 in.)  
140 mm (5.51 in.)  
**Torque - Cylinder Head Bolts (M9):**  
First: 20 N·m (2.0 kgf·m, 15 ft·lb)  
Final: 39 N·m (4.0 kgf·m, 29 ft·lb)
- Tighten the M6 cylinder head bolts [11].  
**Torque - Cylinder Head Bolts (M6): 12 N·m (1.2 kgf·m, 104 in·lb)**
- Install:  
Right and Left Upper Engine Mounting Bolts (see Engine Installation in the Engine Removal/Installation chapter)  
Front Camshaft Chain Guide [A]  
Rear Camshaft Chain Guide [B]  
O-rings [C]  
Collar [D]  
Washer [E]
- Tighten:  
**Torque - Front Camshaft Chain Guide Bolt (Upper) [F]: 25 N·m (2.5 kgf·m, 18 ft·lb)**  
**Front Camshaft Chain Guide Bolt (Lower) [G]: 12 N·m (1.2 kgf·m, 104 in·lb)**  
**Rear Camshaft Chain Guide Bolt [H]: 25 N·m ( 2.5 kgf·m, 18 ft·lb)**
- Install the removed parts (see appropriate chapters).

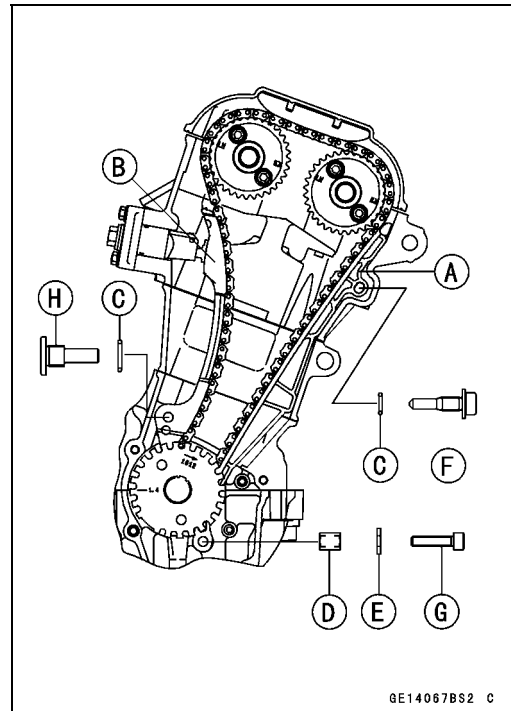
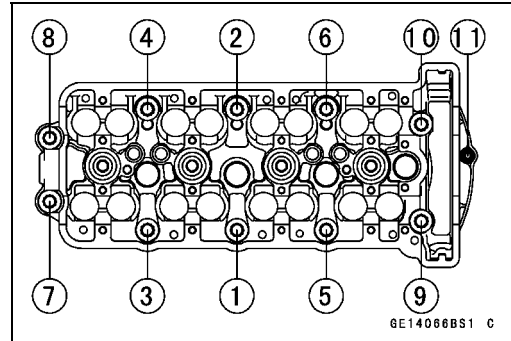

### Cylinder Head Warp

- Clean the cylinder head.
- Lay a straightedge across the lower surface of the cylinder head at several positions.
- Use a thickness gauge [A] to measure the space between the straightedge [B] and the head.

#### Cylinder Head Warp

**Standard:** - - -

**Service Limit: 0.05 mm (0.002 in.)**

- ★ If the cylinder head is warped more than the service limit, replace it.
- ★ If the cylinder head is warped less than the service limit, repair the head by rubbing the lower surface on emery paper secured to a surface plate (first No. 200, then No. 400).

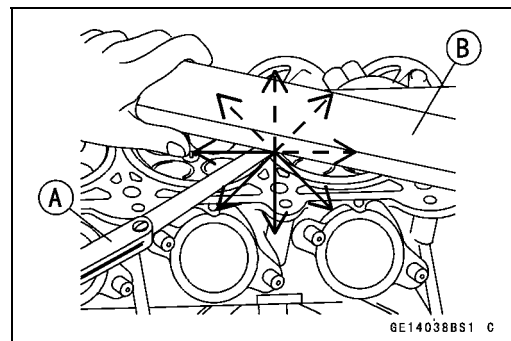

## Valves

### Valve Clearance Inspection

- Refer to the Valve Clearance Inspection in the Periodic Maintenance chapter.

### Valve Clearance Adjustment

- Refer to the Valve Clearance Adjustment in the Periodic Maintenance chapter.

### Valve Removal

- Remove the cylinder head (see Cylinder Head Removal in this chapter).
- Remove the valve lifter and shim.
- Mark and record the valve lifter and shim locations so they can be installed in their original positions.
- Using the valve spring compressor assembly, remove the valve.

**Special Tools - Valve Spring Compressor Assembly [A]:**  
57001-241

**Valve Spring Compressor Adapter,  $\phi$ 21 [B]:**  
57001-1272

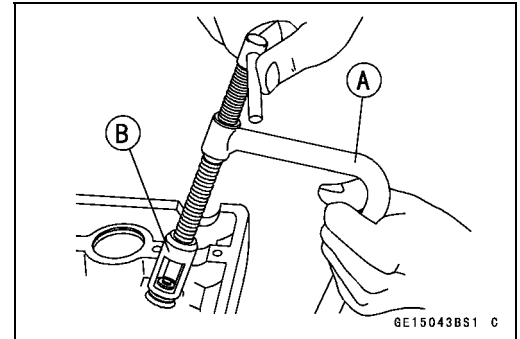

### Valve Installation

- Replace the oil seal with a new one.
- Apply a thin coat of molybdenum disulfide grease to the valve stem before valve installation.
- Install the springs so that the closed coil end faces downwards.

Valve Stem [A]

Oil Seal [B]

Spring Seat [C]

Closed Coil End [D]

Valve Spring [E]:

Exhaust-Yellow Paint

Inlet-Red Paint

Retainer [F]

Split Keepers [G]

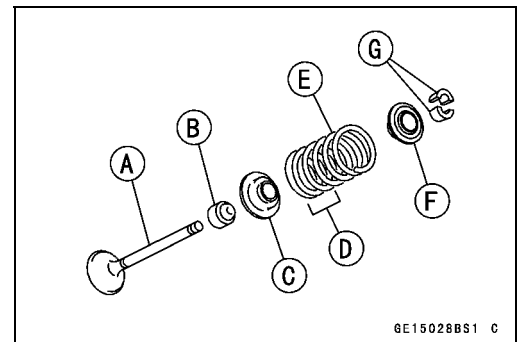

### Valve Guide Removal

- Remove:
  - Valve (see Valve Removal in this chapter)
  - Oil Seal
  - Spring Seat
- Heat the area around the valve guide to 120 ~ 150°C (248 ~ 302°F), and hammer lightly on the valve guide arbor [A] to remove the guide from the top of the head.

### CAUTION

**Do not heat the cylinder head with a torch. This will warp the cylinder head. Soak the cylinder head in oil and heat the oil.**

**Special Tool - Valve Guide Arbor,  $\phi$ 4: 57001-1273**

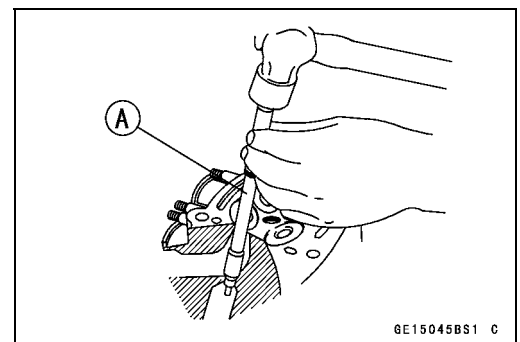

## 5-24 ENGINE TOP END

### Valves

#### Valve Guide Installation

- Apply engine oil to the valve guide outer surface before installation.
- Heat the area around the valve guide hole to about 120 ~ 150°C (248 ~ 302°F).

#### CAUTION

**Do not heat the cylinder head with a torch. This Will warp the cylinder head. Soak the cylinder head and heat the oil.**

- Using the valve guide driver and attachment [A], press and insert the valve guide in until the attachment surface [B] touches the head surface [C].  
13.3 ~ 13.5 mm (0.52 ~ 0.53 in.) [D]

**Special Tools - Valve Guide Driver: 57001-1564**  
**Attachment C: 57001-1624**

- Ream the valve guide with valve guide reamer [A], even if the old guide is reused.

**Special Tool - Valve Guide Reamer,  $\phi 4$ : 57001-1274**

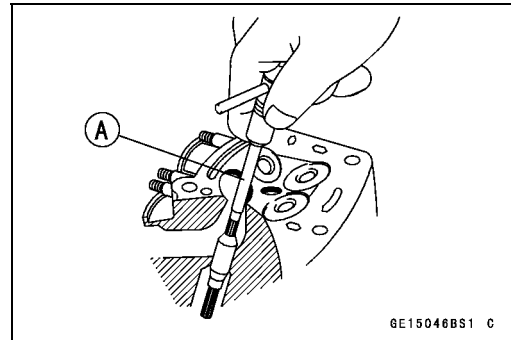
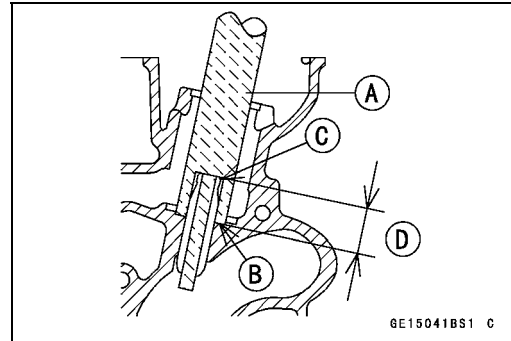

#### Valve-to-Guide Clearance Measurement (Wobble Method)

If a small bore gauge is not available, inspect the valve guide wear by measuring the valve to valve guide clearance with the wobble method as indicated below.

- Insert a new valve [A] into the guide [B] and set a dial gauge against the stem perpendicular to it as close as possible to the cylinder head mating surface.
  - Move the stem back and forth [C] to measure valve/valve guide clearance.
  - Repeat the measurement in a direction at a right angle to the first.
- ★ If the reading exceeds the service limit, replace the guide.

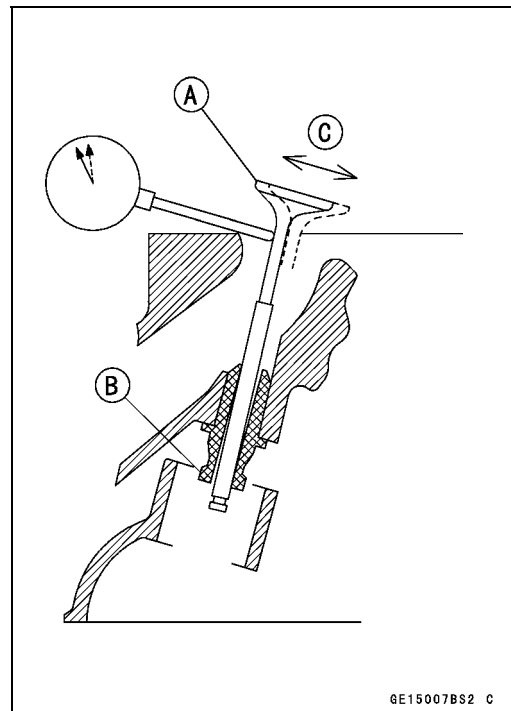

## Valves

### NOTE

○The reading is not actual valve/valve guide clearance because the measuring point is above the guide.

#### Valve/Valve Guide Clearance (Wobble Method)

##### Standard:

Exhaust	0.09 ~ 0.16 mm (0.0035 ~ 0.0063 in.)
Inlet	0.03 ~ 0.11 mm (0.0012 ~ 0.0043 in.)

##### Service Limit:

Exhaust	0.40 mm (0.016 in.)
Inlet	0.35 mm (0.014 in.)

#### Valve Seat Inspection

- Remove the valve (see Valve Removal in this chapter).
- Check the valve seating surface [A] between the valve [B] and valve seat [C].
- Measure the outside diameter [D] of the seating pattern on the valve seat.
- ★ If the outside diameter is too large or too small, repair the seat (see Valve Seat Repair in this chapter).

#### Valve Seating Surface Outside Diameter

##### Standard:

Exhaust	23.5 ~ 23.7 mm (0.925 ~ 0.933 in.)
Inlet	27.9 ~ 28.1 mm (1.098 ~ 1.106 in.)

- Measure the seat width [E] of the portion where there is no build-up carbon (white portion) of the valve seat with a vernier caliper.

Good [F]

- ★ If the width is too wide [G], too narrow [H] or uneven [J], repair the seat (see Valve Seat Repair in this chapter).

#### Valve Seating Surface Width

##### Standard:

Exhaust	0.6 ~ 1.0 mm (0.024 ~ 0.039 in.)
Inlet	0.8 ~ 1.2 mm (0.031 ~ 0.047 in.)

#### Valve Seat Repair

- Repair the valve seat with the valve seat cutters [A].

Special Tools - Valve Seat Cutter Holder Bar [C]: 57001-1128

Valve Seat Cutter Holder,  $\phi 4$  [B]: 57001-1275

##### For Exhaust Valve Seat

Valve Seat Cutter, 45° - $\phi 27.5$ :	57001-1114
Valve Seat Cutter, 32° - $\phi 28$ :	57001-1119
Valve Seat Cutter, 60° - $\phi 27$ :	57001-1409

##### For Inlet Valve Seat

Valve Seat Cutter, 45° - $\phi 24.5$ :	57001-1113
Valve Seat Cutter, 32° - $\phi 25$ :	57001-1118
Valve Seat Cutter, 60° - $\phi 25$ :	57001-1328

- ★ If the manufacturer's instructions are not available, use the following procedure.

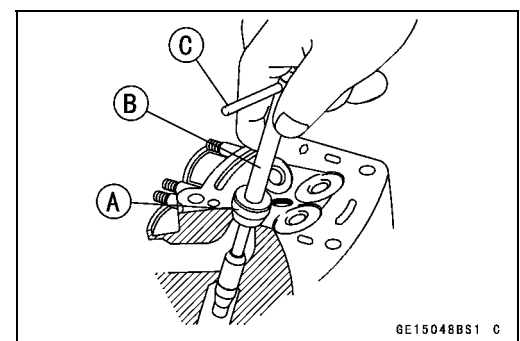
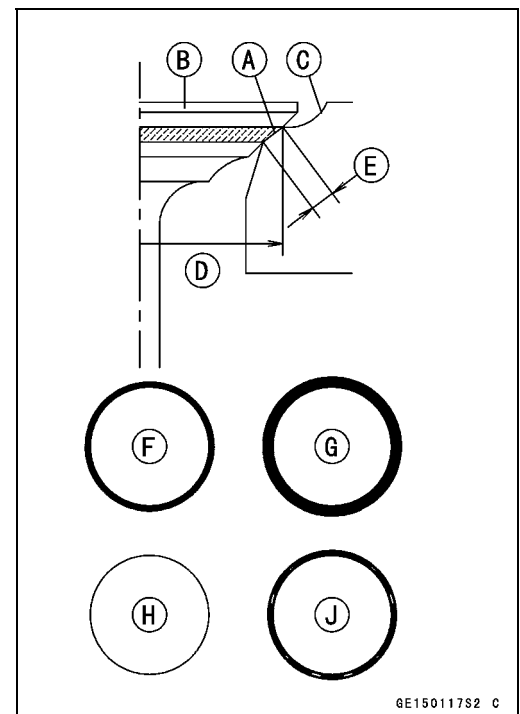

## 5-26 ENGINE TOP END

### Valves

#### Seat Cutter Operation Care

1. This valve seat cutter is developed to grind the valve for repair. Therefore the cutter must not be used for other purposes than seat repair.
2. Do not drop or shock the valve seat cutter, or the diamond particles may fall off.
3. Do not fail to apply engine oil to the valve seat cutter before grinding the seat surface. Also wash off ground particles sticking to the cutter with washing oil.

#### NOTE

○Do not use a wire brush to remove the metal particles from the cutter. It will take off the diamond particles.

4. Setting the valve seat cutter holder in position, operate the cutter in one hand. Do not apply too much force to the diamond portion.

#### NOTE

○Prior to grinding, apply engine oil to the cutter and during the operation, wash off any ground particles sticking to the cutter with washing oil.

5. After use, wash it with washing oil and apply thin layer of engine oil before storing.

#### Marks Stamped on the Cutter

The marks stamped on the back of the cutter [A] represent the following.

- 60° ..... Cutter angle [B]  
φ37.5 ..... Outer diameter of cutter [C]

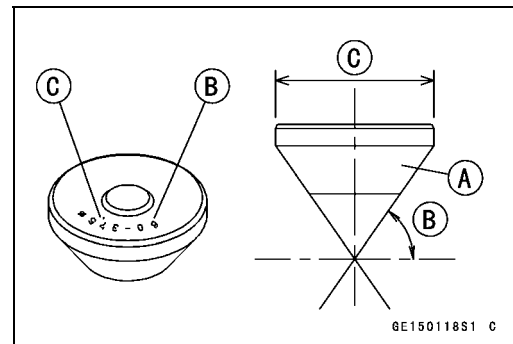

#### Operating Procedures

- Clean the seat area carefully.
- Coat the seat with machinist's dye.
- Fit a 45° cutter into the holder and slide it into the valve guide.
- Press down lightly on the handle and turn it right or left. Grind the seating surface only until it is smooth.

#### CAUTION

**Do not grind the seat too much. Overgrinding will reduce valve clearance by sinking the valve into the head. If the valve sinks too far into the head, it will be impossible to adjust the clearance, and the cylinder head must be replaced.**

## Valves

- Measure the outside diameter of the seating surface with a vernier caliper.
- ★ If the outside diameter of the seating surface is too small, repeat the 45° grind until the diameter is within the specified range.
  - Widened Width [A] of engagement by machining with 45° cutter
  - Ground Volume [B] by 32° cutter
  - 32° [C]
  - Correct Width [D]
  - Ground Volume [E] by 60° cutter
  - 60° [F]

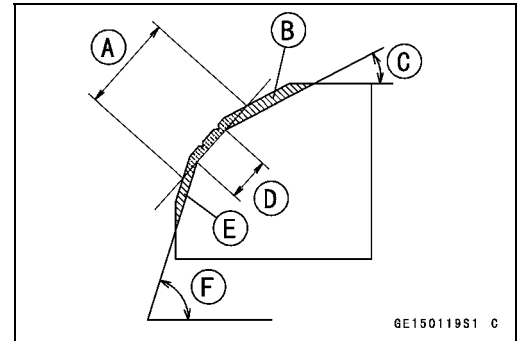

- Measure the outside diameter of the seating surface with a vernier caliper.
- ★ If the outside diameter of the seating surface is too small, repeat the 45° grind [A] until the diameter is within the specified range.
  - Original Seating Surface [B]

### NOTE

- Remove all pittings of flaws from 45° ground surface.
- After grinding with 45° cutter, apply thin coat of machinist's dye to seating surface. This makes seating surface distinct and 32° and 60° grinding operation easier.
- When the valve guide is replaced, be sure to grind with 45° cutter for centering and good contact.

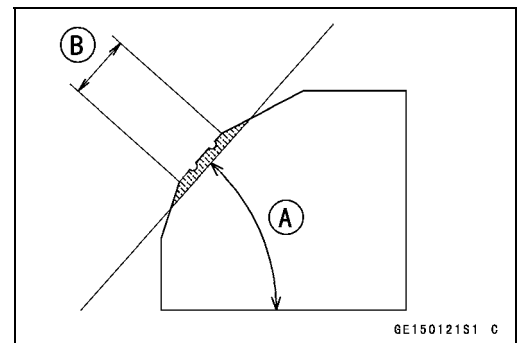

- ★ If the outside diameter [A] of the seating surface is too large, make the 32° grind described below.
- ★ If the outside diameter of the seating surface is within the specified range, measure the seat width as described below.
- Grind the seat at a 32° angle [B] until the seat outside diameter is within the specified range.
  - To make the 32° grind, fit a 32° cutter into the holder, and slide it into the valve guide.
  - Turn the holder one turn at a time while pressing down very lightly. Check the seat after each turn.

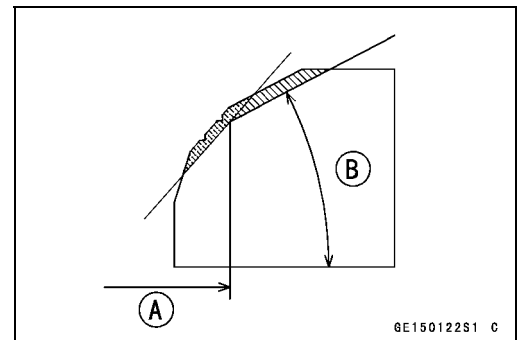

### CAUTION

**The 32° cutter removes material very quickly. Check the seat outside diameter frequently to prevent overgrinding.**

- After making the 32° grind, return to the seat outside diameter measurement step above.
- To measure the seat width, use a vernier caliper to measure the width of the 45° angle portion of the seat at several places around the seat.
- ★ If the seat width is too narrow, repeat the 45° grind until the seat is slightly too wide, and then return to the seat outside diameter measurement step above.

## 5-28 ENGINE TOP END

### Valves

- ★ If the seat width is too wide, make the 60° [A] grind described below.
- ★ If the seat width is within the specified range, lap the valve to the seat as described below.
- Grind the seat at a 60° angle until the seat width is within the specified range.
- To make the 60° grind, fit 60° cutter into the holder, and slide it into the valve guide.
- Turn the holder, while pressing down lightly.
- After making the 60° grind, return to the seat width measurement step above.

Correct Width [B]

- Lap the valve to the valve seat, once the seat width and outside diameter are within the ranges specified above.
- Put a little coarse grinding compound on the face of the valve in a number of places around the valve head.
- Spin the valve against the seat until the grinding compound produces a smooth, matched surface on both the seat and the valve.
- Repeat the process with a fine grinding compound.

Lapper [A]

Valve Seat [B]

Valve [C]

- The seating area should be marked about in the middle of the valve face.
- ★ If the seat area is not in the right place on the valve, check to be sure the valve is the correct part. If it is, it may have been refaced too much; replace it.
- Be sure to remove all grinding compound before assembly.
- When the engine is assembled, be sure to adjust the valve clearance (see Valve Clearance Inspection in the Periodic Maintenance chapter).

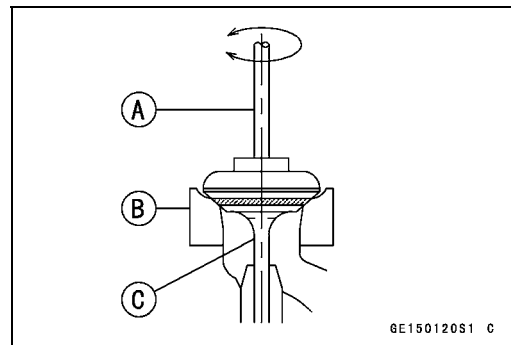
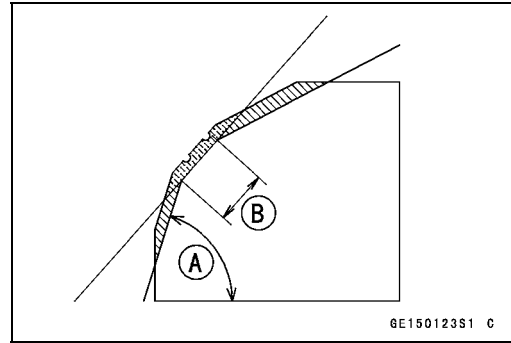

Valves

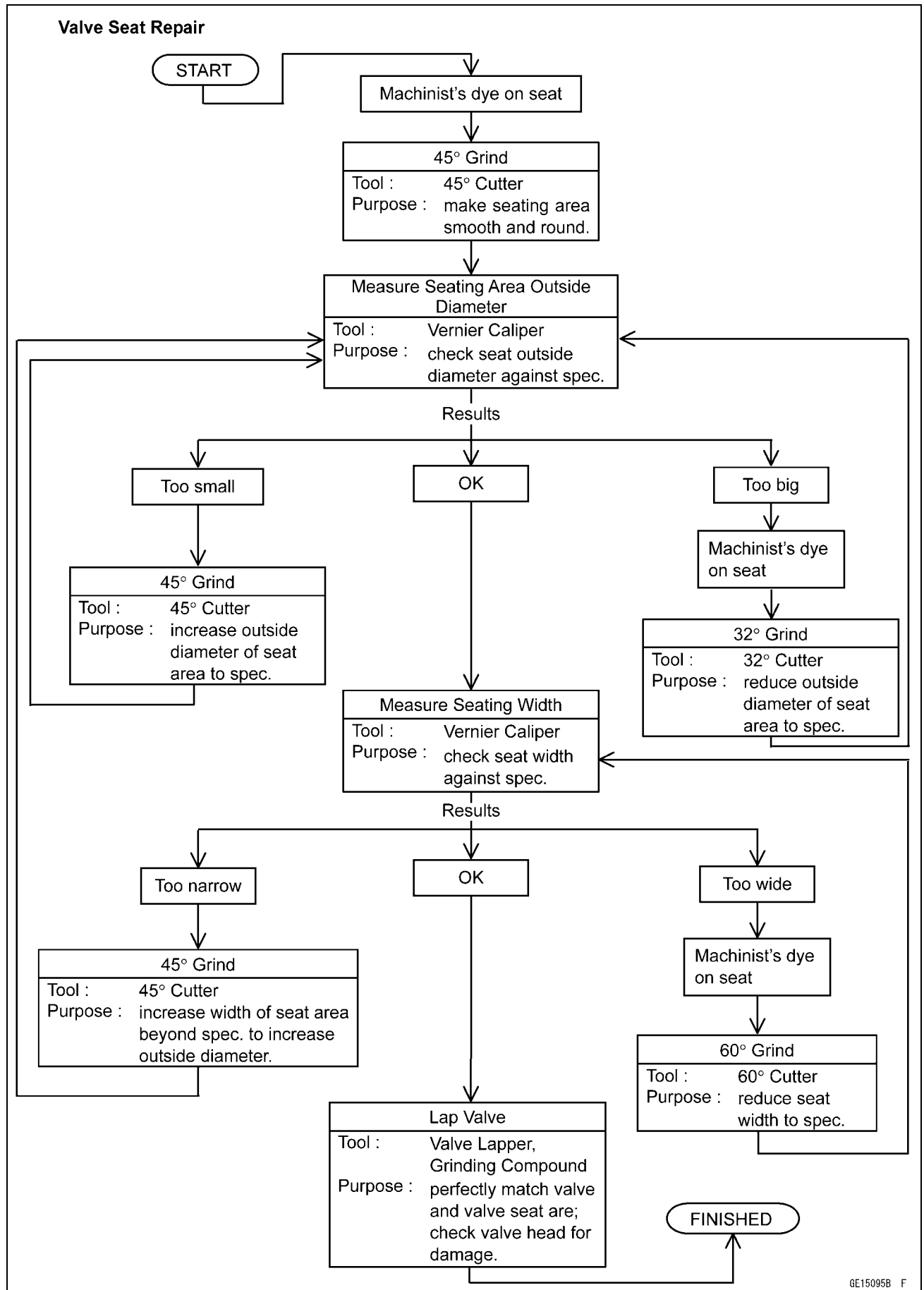

## 5-30 ENGINE TOP END

### Cylinder, Pistons

#### Cylinder Removal

- Remove:
  - Cylinder Head (see Cylinder Head Removal in this chapter)
  - Water Hoses [A]

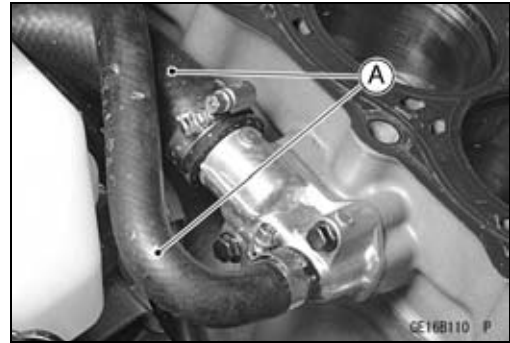

- Remove the cylinder [A].



#### Cylinder Installation

##### NOTE

○ If a new cylinder is used, use new piston ring.

- Install the dowel pins [A] and new cylinder gasket [B].
- Apply engine oil to the cylinder bore.

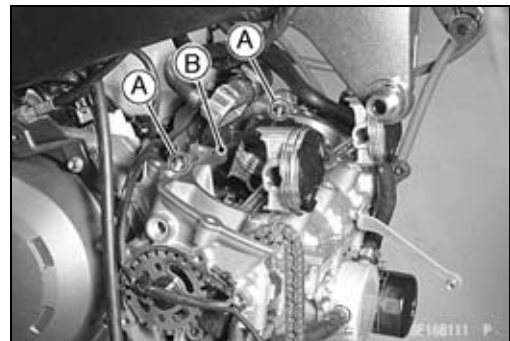

- The piston ring openings must be positioned as shown in the figure. The openings of the oil ring steel rails must be about 30 ~ 40° of angle from the opening of the top ring.

- Top Ring [A]
- Second Ring [B]
- Upper Oil Ring Steel Rail [C]
- Oil Ring Expander [D]
- Lower Oil Ring Steel Rail [E]
- Hollow [F]
- 30 ~ 40° [G]

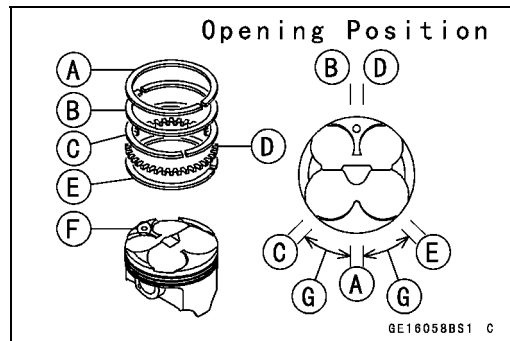

- Position the crankshaft at #2, 3 piston TDC.
- Prepare two auxiliary head bolts with their head cut.
- Install the two cylinder head bolts [A] diagonally in the crankcase.
- Install the cylinder block [B].
- Pistons [C]
- First insert the #2, 3 pistons, and then rotate the crankshaft at 90° angle.
- Insert the piston rings with your thumbs or the thin (-) screwdriver.

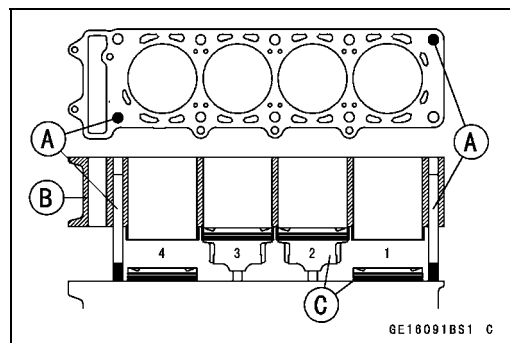

## Cylinder, Pistons

### Piston Removal

- Remove the cylinder (see Cylinder Removal in this chapter).
- Place a clean cloth under the pistons and remove the piston pin snap ring [A] from the outside of each piston.

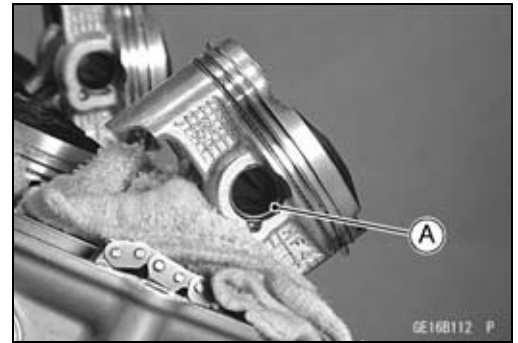

- Remove the piston pins.
  - Special Tool - Piston Pin Puller Assembly [A]: 57001-910
- Remove the pistons.

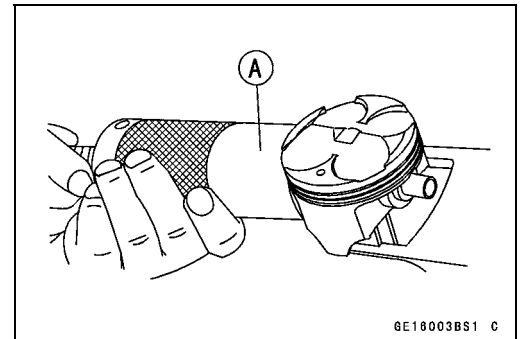

- Carefully spread the ring opening with your thumbs and then push up on the opposite side of the ring [A] to remove it.
- Remove the 3-piece oil ring with your thumbs in the same manner.

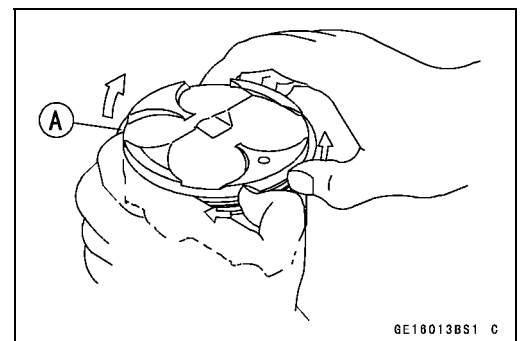

### Piston Installation

- Install the oil ring expander [A] in the bottom piston ring groove so the ends [B] not butt together.
- Install the oil ring steel rails, one above the expander and one below it.
- Spread the rail with your thumbs, but only enough to fit the rail over the piston.
- Release the rail into the bottom piston ring groove.

#### NOTE

- The oil ring steel rails have no "top" or "bottom".

- Do not mix up the top and second ring.
- Install the top ring [A] so that the "R" mark [B] faces up.
- Install the second ring [C] so that the "RN" mark [D] faces up.
- Apply molybdenum disulfide oil solution to the piston rings.

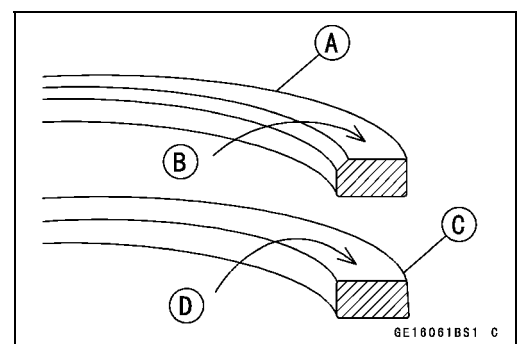
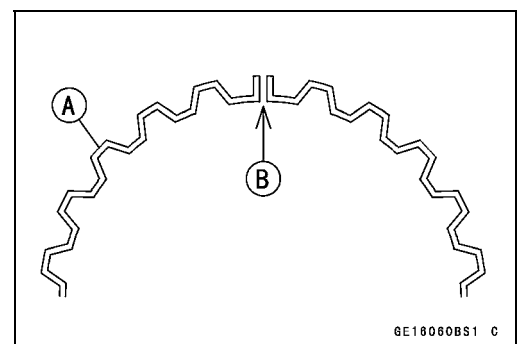

## 5-32 ENGINE TOP END

### Cylinder, Pistons

#### NOTE

○ If a new piston is used, use new piston ring.

- Install the piston with its marking hollow facing forward.
- Fit a new piston pin snap ring into the side of the piston so that the ring opening [A] does not coincide with the slit [B] of the piston pin hole.
- Apply molybdenum disulfide oil solution to the piston pins and piston journals.
- When installing the piston pin snap ring, compress it only enough to install it and no more.

#### CAUTION

**Do not reuse snap rings, as removal weakens and deforms them. They could fall out and score the cylinder wall.**

- Install the cylinder (see Cylinder Installation in this chapter).

#### Cylinder Wear

- Since there is a difference in cylinder wear in different directions, take a side-to-side and a front-to-back measurement at each of the two locations (total of four measurements) shown in the figure.
- ★ If any of the cylinder inside diameter measurements exceeds the service limit, replace the cylinder.
  - 10 mm (0.39 in.) [A]
  - 60 mm (2.36 in.) [B]

#### Cylinder Inside Diameter

**Standard:** 68.000 ~ 68.012 mm (2.677 ~ 2.678 in.)

**Service Limit:** 68.10 mm (2.68 in.)

#### Piston Wear

- Measure the outside diameter [A] of each piston 10 mm (0.39 in.) [B] up from the bottom of the piston at a right angle to the direction of the piston pin.
- ★ If the measurement is under service limit, replace the piston.

#### Piston Diameter

**Standard:** 67.975 ~ 67.990 mm (2.676 ~ 2.679 in.)

**Service Limit:** 67.53 mm (2.66 in.)

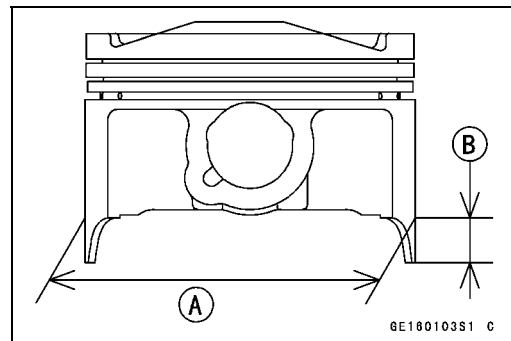
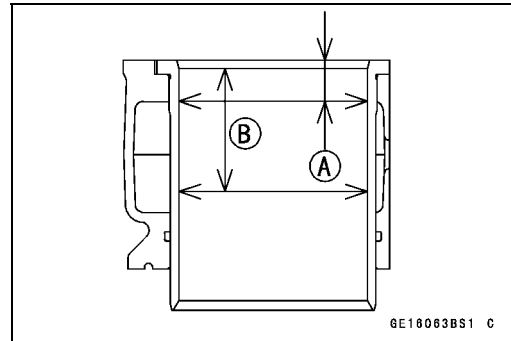
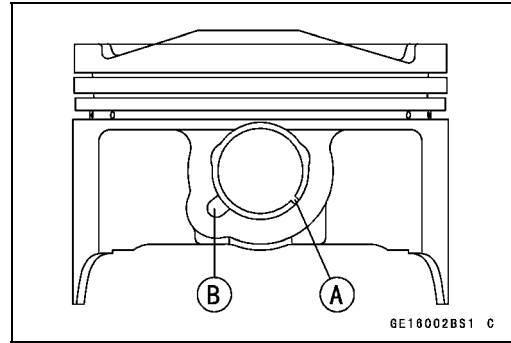

## Cylinder, Pistons

### Piston Ring, Piston Ring Groove Wear

- Check for uneven groove wear by inspecting the ring seating.
- ★ The rings should fit perfectly parallel to groove surfaces. If not, replace the piston and all the piston rings.
- With the piston rings in their grooves, make several measurements with a thickness gauge [A] to determine piston ring/groove clearance.

#### Piston Ring/Groove Clearance

##### Standard:

Top	0.03 ~ 0.07 mm (0.0012 ~ 0.0028 in.)
Second	0.03 ~ 0.07 mm (0.0012 ~ 0.0028 in.)

##### Service Limit:

Top	0.17 mm (0.0067 in.)
Second	0.17 mm (0.0067 in.)

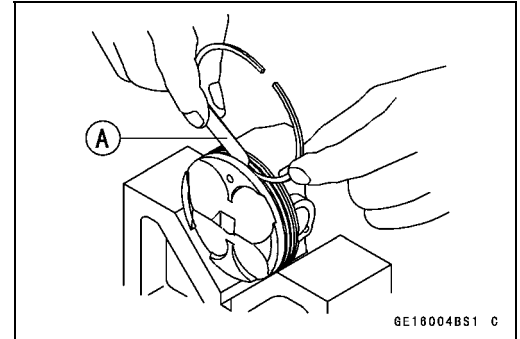

0E18004BS1 C

### Piston Ring Groove Width

- Measure the piston ring groove width.
- Use a vernier caliper at several points around the piston.

#### Piston Ring Groove Width

##### Standard:

Top [A]	0.82 ~ 0.84 mm (0.0323 ~ 0.0331 in.)
Second [B]	0.82 ~ 0.84 mm (0.0323 ~ 0.0331 in.)

##### Service Limit:

Top [A]	0.92 mm (0.036 in.)
Second [B]	0.92 mm (0.036 in.)

- ★ If the width of any of the two grooves is wider than the service limit at any point, replace the piston.

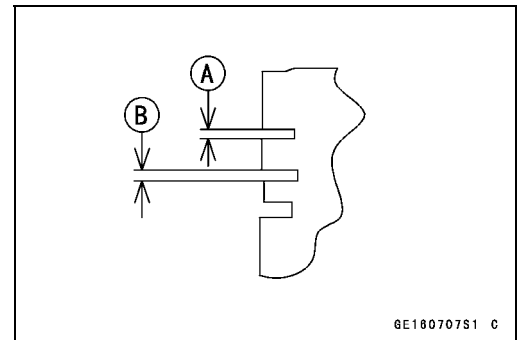

0E180707S1 C

### Piston Ring Thickness

- Measure the piston ring thickness.
- Use the micrometer to measure at several points around the ring.

#### Piston Ring Thickness

##### Standard:

Top [A]	0.77 ~ 0.79 mm (0.0303 ~ 0.0311 in.)
Second [B]	0.77 ~ 0.79 mm (0.0303 ~ 0.0311 in.)

##### Service Limit:

Top [A]	0.70 mm (0.028 in.)
Second [B]	0.70 mm (0.028 in.)

- ★ If any of the measurements is less than the service limit on either of the rings, replace all the rings.

### NOTE

- When using new rings in a used piston, check for uneven groove wear. The rings should fit perfectly parallel to the groove sides. If not, replace the piston.

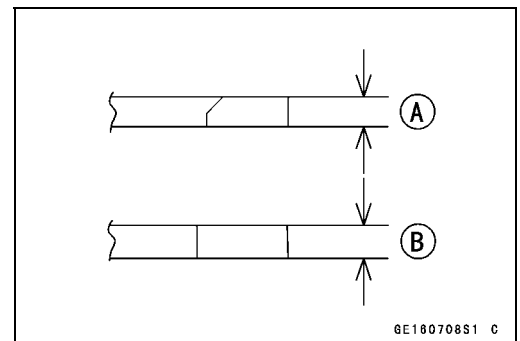

0E180708S1 C

## 5-34 ENGINE TOP END

### Cylinder, Pistons

#### *Piston Ring End Gap*

- Place the piston ring [A] inside the cylinder, using the piston to locate the ring squarely in place. Set it close to the bottom of the cylinder, where cylinder wear is low.
- Measure the gap [B] between the ends of the ring with a thickness gauge.

#### **Piston Ring End Gap**

##### **Standard:**

**Top**            **0.12 ~ 0.22 mm (0.0047 ~ 0.0087 in.)**

**Second**       **0.30 ~ 0.45 mm (0.0118 ~ 0.0177 in.)**

##### **Service Limit:**

**Top**            **0.5 mm (0.020 in.)**

**Second**       **0.8 mm (0.031 in.)**

- ★If the end gap of either ring is greater than the service limit, replace all the rings.

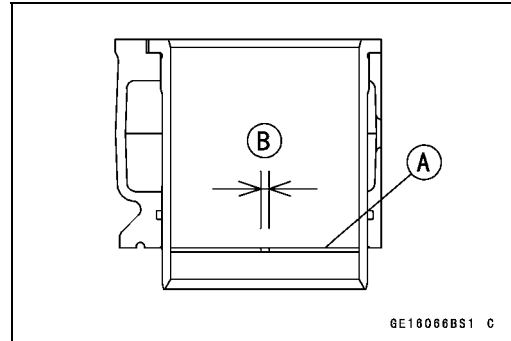

## Throttle Body Holder

### *Throttle Body Holder Installation*

- Be sure to install the O-rings [A].
- Install the clamps [B] as shown.
- Apply a non-permanent locking agent to the throttle body holder bolts, and tighten them.

**Torque - Throttle Body Holder Bolts [C]: 12 N·m (1.2 kgf·m, 104 in·lb)**

**Throttle Body Assy Holder Clamp Bolts [D]: 2.9 N·m (0.30 kgf·m, 26 in·lb)**

Upside [E]

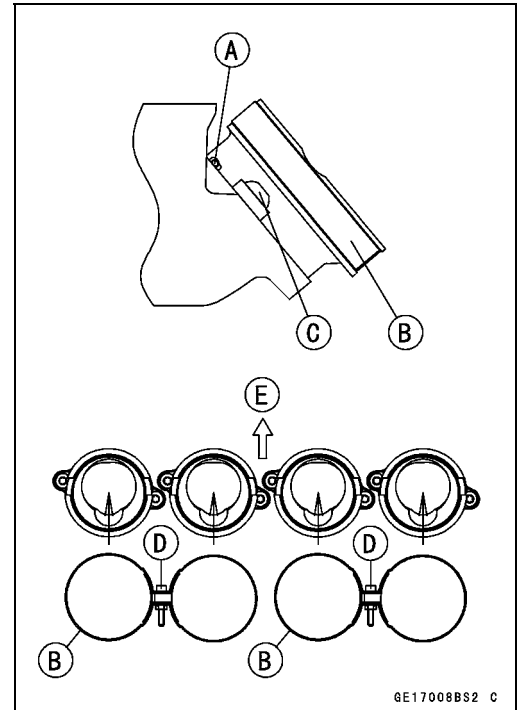

GE17008BS2 C

## 5-36 ENGINE TOP END

### Muffler

#### **⚠ WARNING**

To avoid a serious burn, do not remove the muffler when the engine is still hot. Wait until the muffler cool down.

#### *Muffler Body Removal*

- Remove:
  - Seat Cover (see Seat Cover Removal in the Frame chapter)
  - Clamp [A]
  - Connectors [B]
  - Bolts [C]
  
- Remove:
  - Nuts [A]
  - Bolts [B]
  - Flap [C] (with Licence Plate Light)
  - Turn Signal Lights
  
- Remove:
  - Bolts [A]
  - Screws [B]
  - Covers [C] [D]
  
- Remove:
  - Bolts [A]
  - Cover [B]

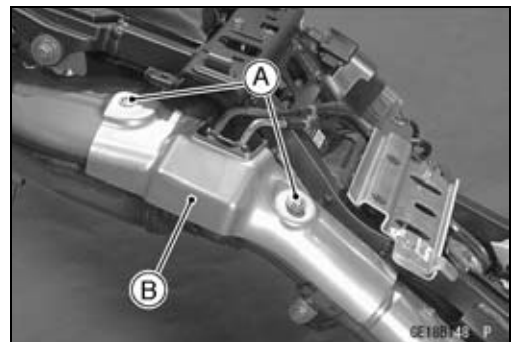
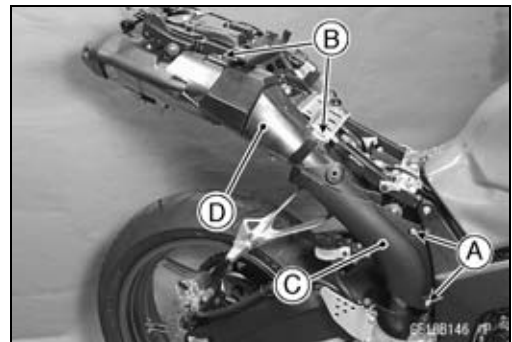
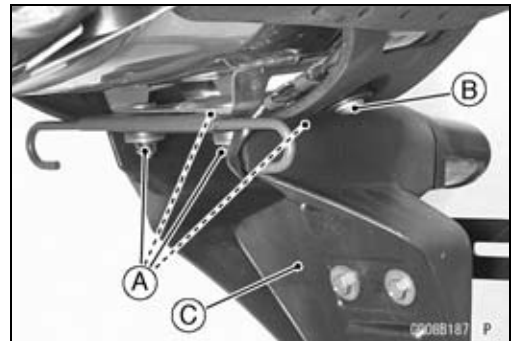
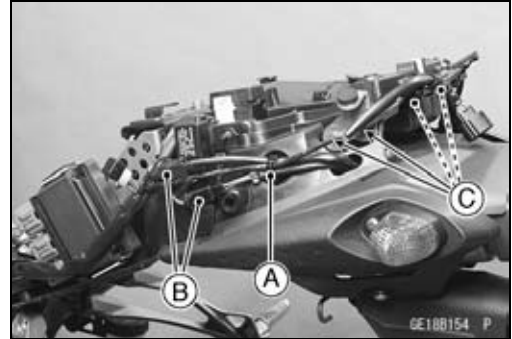

## Muffler

- Slide the dust covers [A].
- Loosen the locknuts [B], and turn the adjuster [C] to give the cable plenty of play.
- Loosen the locknuts [D].
- Remove the exhaust butterfly valve cable lower ends from the pulley [E].

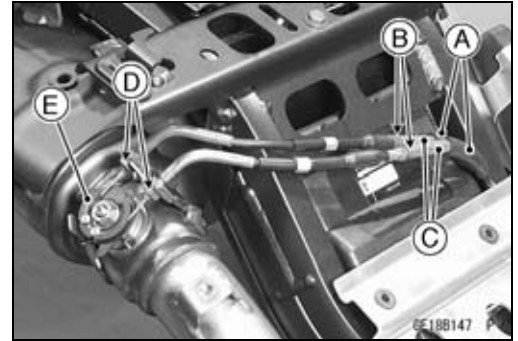

- Loosen the clamp bolt [A].
- Remove the bolts [B].
- Remove the muffler body backward.

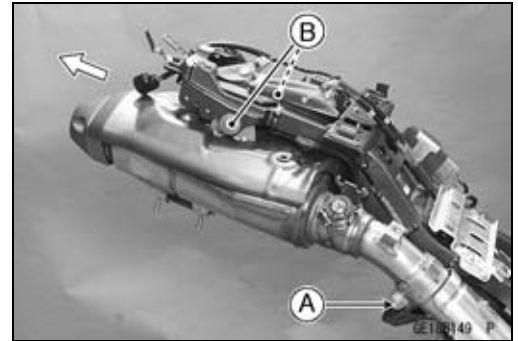

- Remove:
  - Brake Pedal (see Brake Pedal Removal in the Brakes chapter)
  - Bolts [A]
  - Cover [B]
  - Clamp Bolt [C]
  - Bolt [D]
- Remove the center pipe right side of motorcycle.

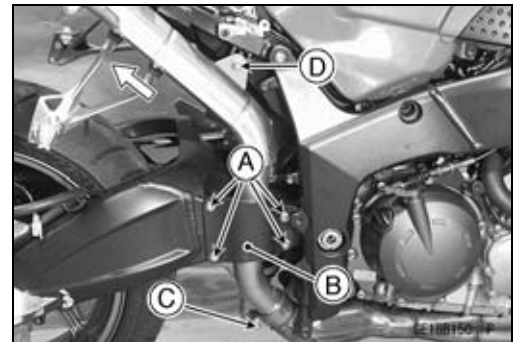

## 5-38 ENGINE TOP END

---

### Muffler

---

#### *Muffler Body Installation*

- Replace the muffler body gasket [A] and center pipe gasket [B] with a new one.
- Install the muffler body gasket and center pipe gasket until it is bottomed so that the chamfer side faces rear.
- Install the center pipe [C].
- Install the center pipe until it stops at the bottom surface of the exhaust pipe.
- Install the exhaust pipe clamp bolt [D] as shown.
  - Upside [E]
  - Outside [F]
  - Rear View [G]
  - About 6 mm (0.24 in.) [H]
- Install the muffler body.
- Install the muffler body until it stops at the bottom surface of the center pipe.
- Install the muffler body clamp bolt as shown.
  - Upside [E]
  - Outside [F]
  - Rear View [G]
  - About 8 mm [I] (0.31 in.)
- Tighten:
  - Torque - Exhaust Pipe Clamp Bolt: 17 N·m (1.7 kgf·m, 12 ft·lb)**
  - Exhaust Pipe Mounting Bolt [J]: 25 N·m (2.5 kgf·m, 18 ft·lb)**
  - Muffler Body Mounting Bolts [K]: 25 N·m (2.5 kgf·m, 18 ft·lb)**
  - Muffler Body Clamp Bolt [L]: 17 N·m (1.7 kgf·m, 12 ft·lb)**

## Muffler

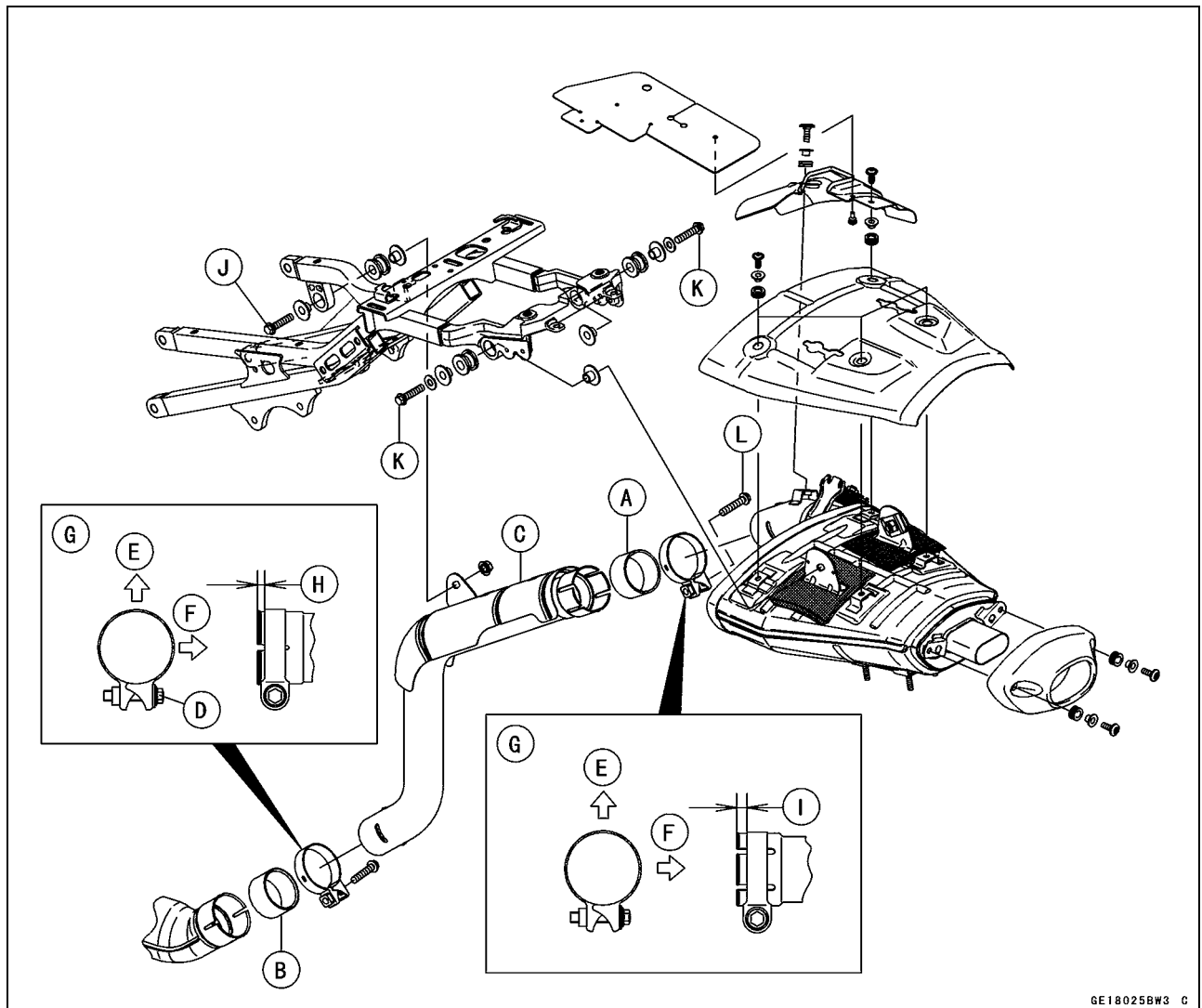

GE18025BW3 C

- Install the exhaust butterfly valve cable, and adjust (see Exhaust Butterfly Valve Cable Installation in this chapter).
- Thoroughly warm up the engine, wait until the engine cools down, retighten all the bolts.
- Install the removed parts (see appropriate chapters).
- When installing, run the each leads correctly (see Cable, Wire, and Hose Routing section in the Appendix chapter).

*Exhaust Pipe Removal*

- Remove:
  - Radiator (see Radiator and Radiator Fan Removal in the Cooling System chapter)
  - Exhaust Pipe Manifold Holder Nuts [A]



GE180151 P

## 5-40 ENGINE TOP END

### Muffler

- Remove:
  - Exhaust Pipe Clamp Bolt [A]
- Remove the exhaust pipe forward.

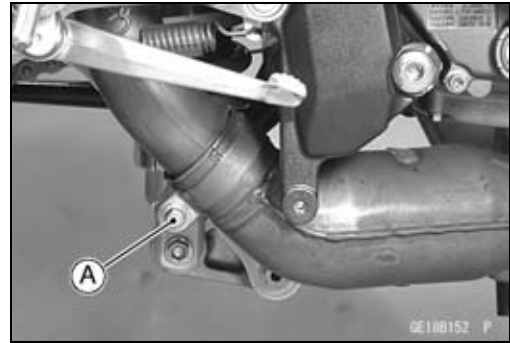

#### Exhaust Pipe Installation

- Replace the exhaust pipe gaskets [A] and center pipe gasket [B] with new ones and install them.
- Install the center pipe gasket until it is bottomed so that the chamfer side faces rear.
- Install:
  - Exhaust Pipe [C]
- Install the exhaust pipe clamp bolt [D] as shown.
  - Upside [E]
  - Outside [F]
  - Rear View [G]
  - About 6 mm (0.24 in.) [H]
- Tighten:
  - Torque - Exhaust Pipe Clamp Bolt: 17 N·m (1.7 kgf·m, 12 ft·lb)**
  - Exhaust Pipe Manifold Holder Nuts [I]: 17 N·m (1.7 kgf·m, 12 ft·lb)**
- Thoroughly warm up the engine, wait until the engine cools down, retighten all the bolts and nuts.

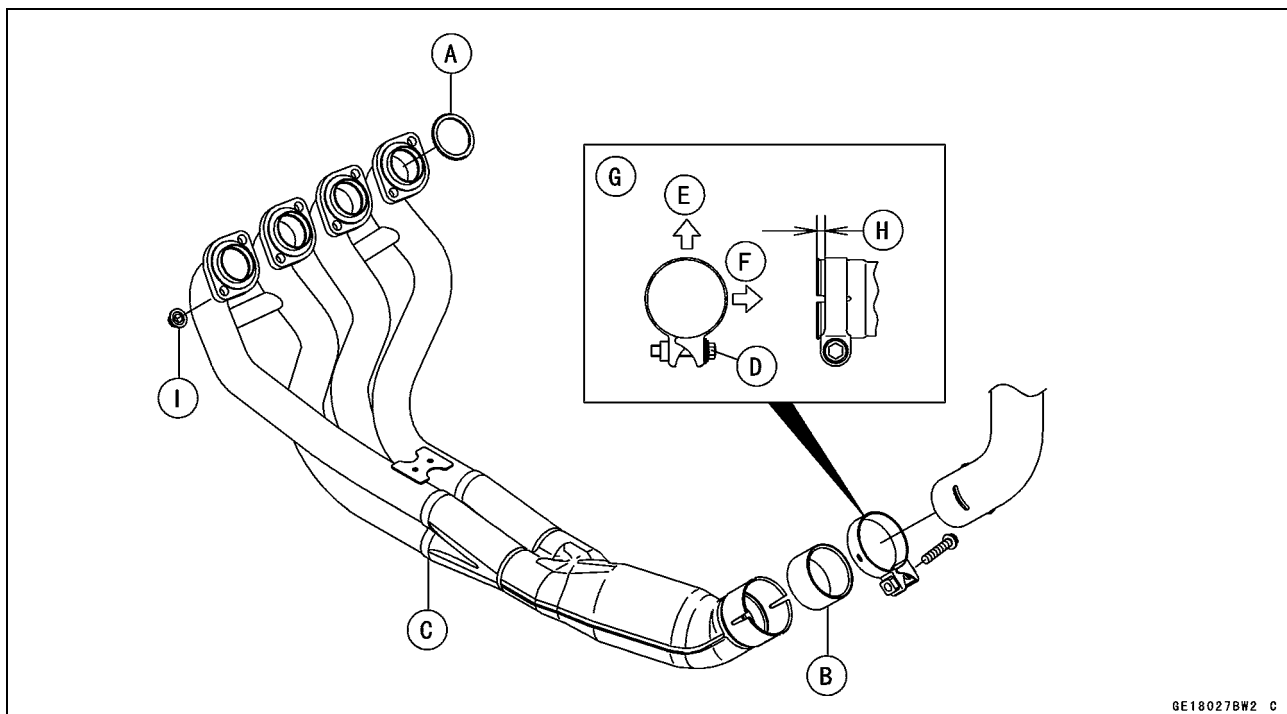

## Muffler

### Exhaust Butterfly Valve Cable Removal

- Remove:
  - Seat Cover (see Seat Cover Removal in the Frame chapter)
  - Guard Bracket [A] (see ECU Removal in the Fuel System chapter)
  - Cover (see Muffler Body Removal in this chapter)
- Slide the dust covers [B].
- Loosen the locknuts [C], and turn the adjuster [D] to give the cable plenty of play.
- Remove the clamp [A].
- Remove the exhaust butterfly valve cable upper ends [B] from the pulley [C].

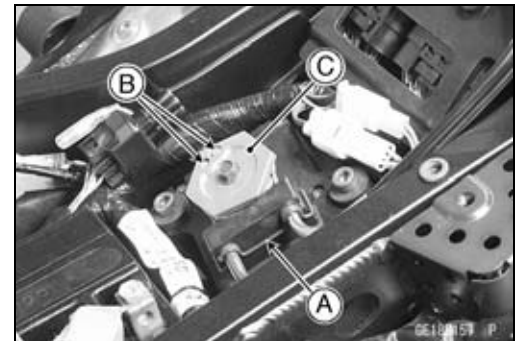
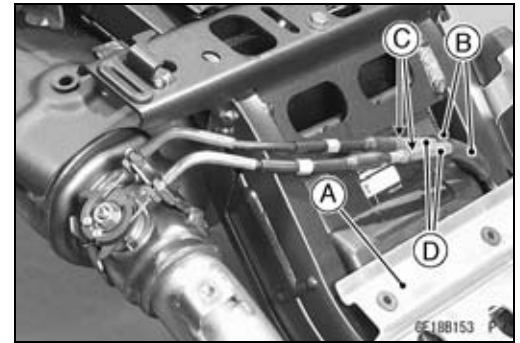

- Loosen the locknuts [A].
- Remove the exhaust butterfly valve cable lower ends [B] from the pulley [C].
- Remove the exhaust butterfly valve cable.

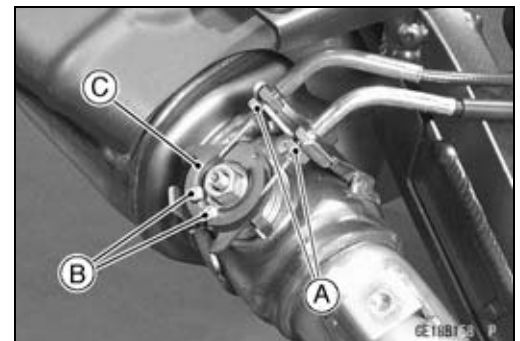

### Exhaust Butterfly Valve Cable Installation

- Confirm whether it is an angle shown in figure.

#### NOTE

○ *Correct the position electrically after confirming use is discontinued, and there is no damage when differing from the angle of shown in the figure.*

- ★ If the angle is wrong, adjust the pulley (see Exhaust Butterfly Valve Actuator Installation in the Fuel System (DFI) chapter).

41.7° ± 7° [A]

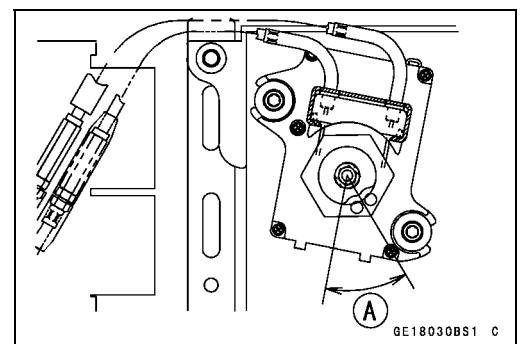

#### CAUTION

**Do not correct it with the tool, forcibly.**

## 5-42 ENGINE TOP END

### Muffler

- Install the exhaust butterfly valve cable upper ends to the pulley of actuator.
  - Open Cable (Yellow) [A]
  - Close Cable (Dark Green) [B]
- Install the clamp.

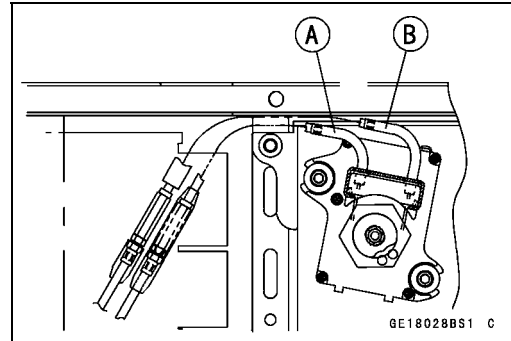

- Install the exhaust butterfly valve cable lower ends to the pulley of muffler body.
  - 6 mm (0.24 in.) [A]
  - About 57° [B]
  - About 42° [C]
- Tighten:
  - Torque - Exhaust Butterfly Valve Cable Locknuts: 6.9 N·m (0.70 kgf·m, 61 in·lb)**

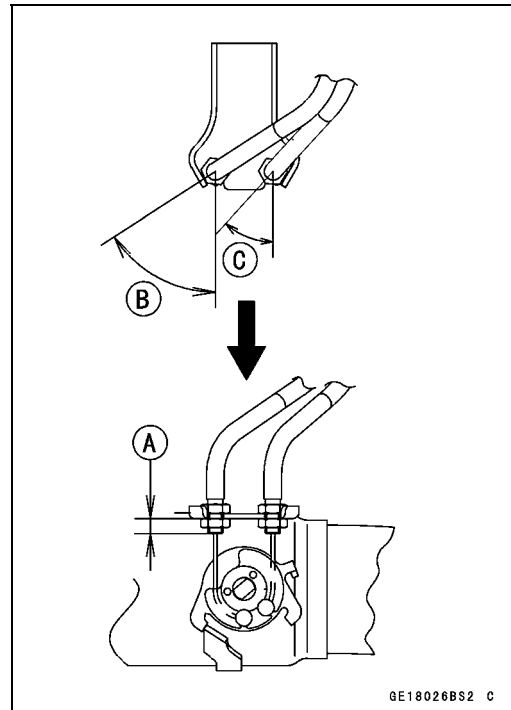

- Install the open cable, and adjust the adjuster [A].

#### CAUTION

**Do not overstretch.**

- Tighten:
  - Torque - Exhaust Butterfly Valve Cable Adjuster Locknut: 6.9 N·m (0.70 kgf·m, 61 in·lb)**
- Install the close cable, and adjust the adjuster [B].
- After the adjustment, return the locknut to the half from one rotation.
- Tighten:
  - Torque - Exhaust Butterfly Valve Cable Adjuster Locknut: 6.9 N·m (0.70 kgf·m, 61 in·lb)**
- Cover the dust covers.
- Install the removed parts (see appropriate chapters).

Muffler

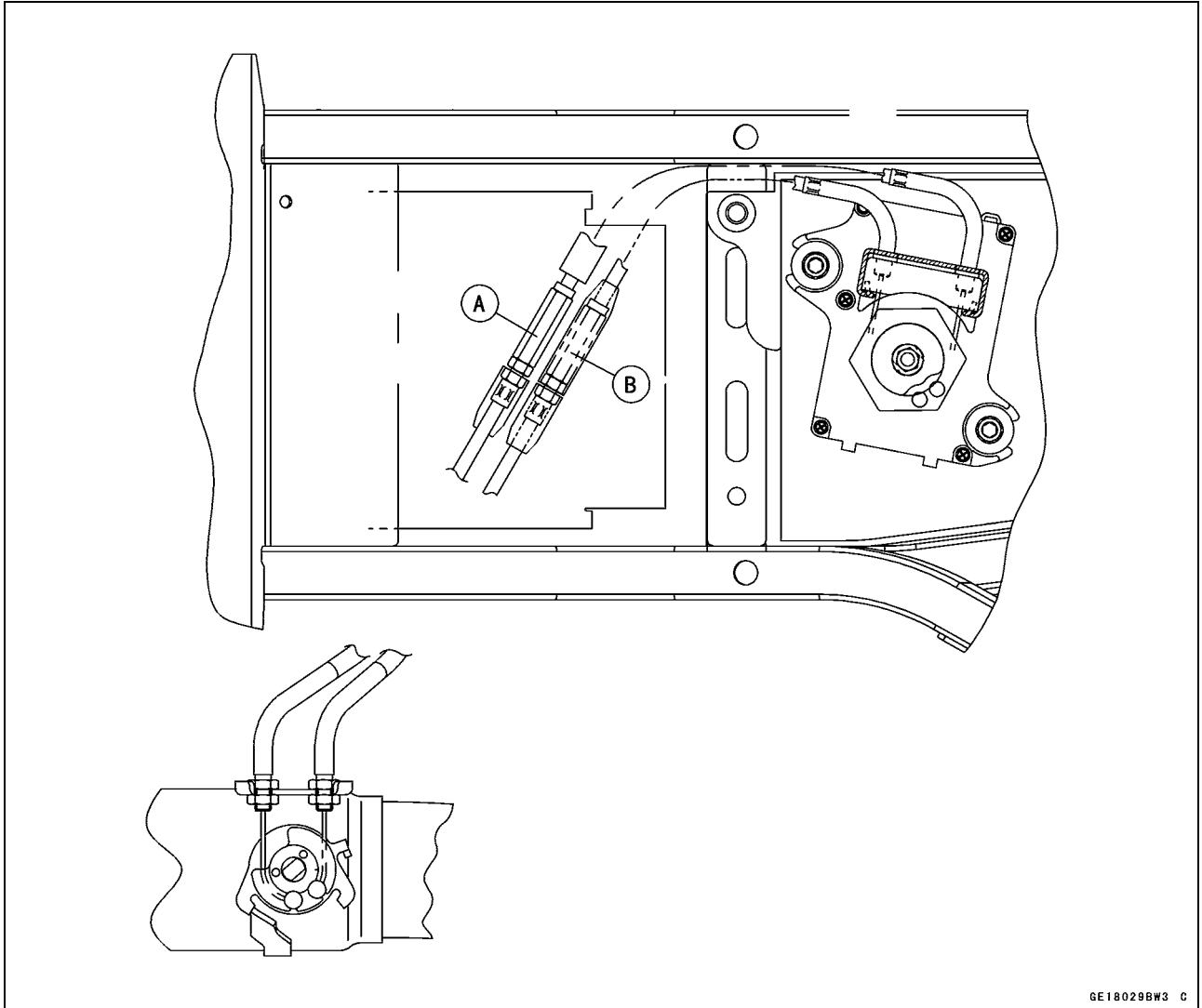



# Clutch

## Table of Contents

Exploded View .....	6-2
Specifications .....	6-4
Special Tool and Sealant .....	6-5
Clutch Lever and Cable .....	6-6
Clutch Lever Free Play Inspection .....	6-6
Clutch Lever Free Play Adjustment .....	6-6
Cable Removal .....	6-6
Cable Installation .....	6-6
Cable Lubrication .....	6-6
Clutch Lever Installation .....	6-6
Clutch Cover .....	6-7
Clutch Cover Removal .....	6-7
Clutch Cover Installation .....	6-7
Release Shaft Removal .....	6-7
Release Shaft Installation .....	6-8
Clutch Cover Disassembly .....	6-8
Clutch Cover Assembly .....	6-8
Clutch .....	6-9
Clutch Removal .....	6-9
Clutch Installation .....	6-10
Spring Plate Free Play Measurement .....	6-14
Spring Plate Play Adjustment .....	6-15
Clutch Plate, Wear, Damage Inspection .....	6-15
Clutch Plate Warp Inspection .....	6-15
Clutch Spring Free Length Measurement .....	6-16
Damper Cam Inspection .....	6-16

# 6-2 CLUTCH

## Exploded View

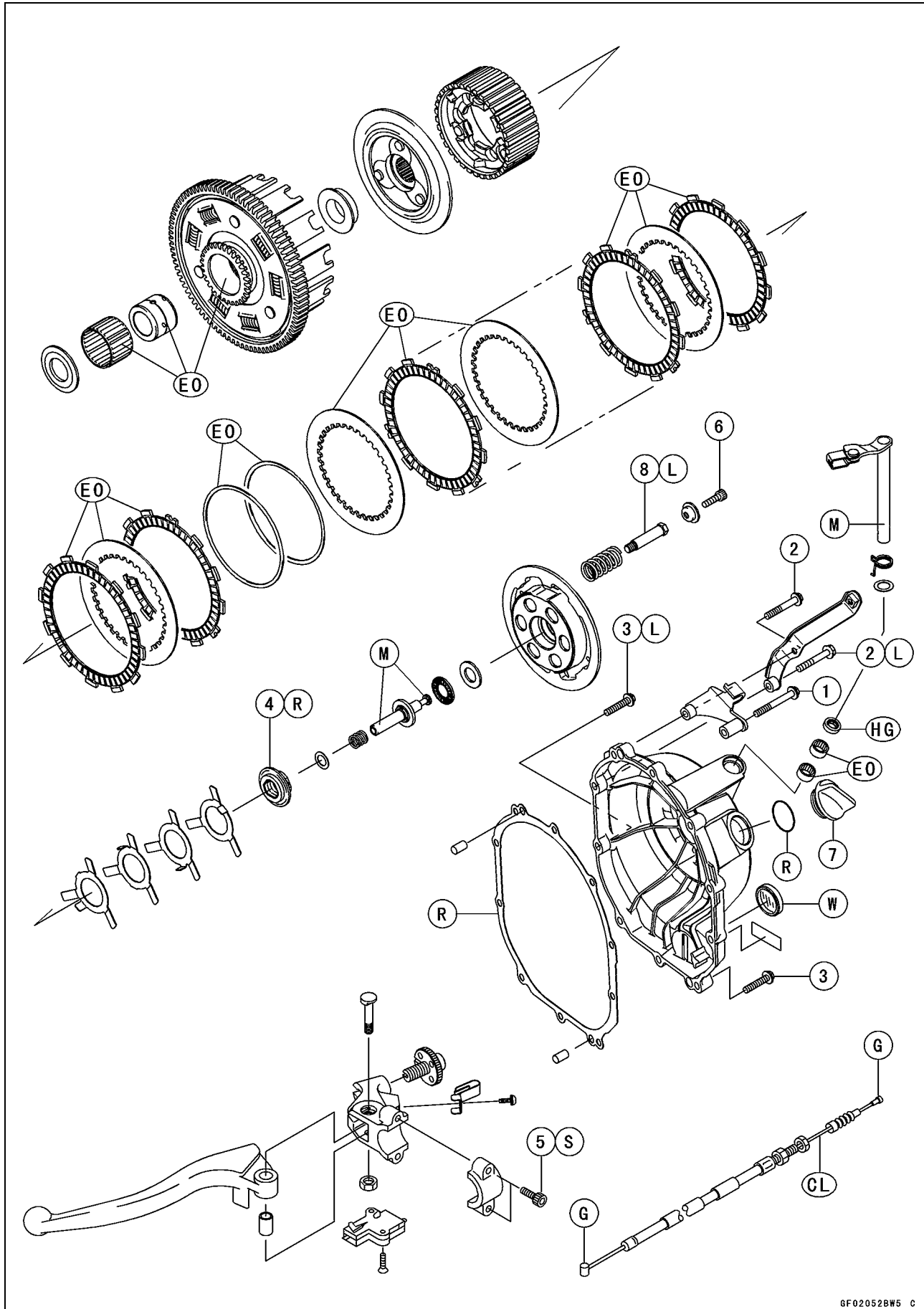

## Exploded View

No.	Fastener	Torque			Remarks
		N·m	kgf·m	ft·lb	
1	Clutch Cover Bolt (M6, L = 50 mm)	12	1.2	104 in·lb	
2	Clutch Cover Bolts (M6, L = 40 mm)	12	1.2	104 in·lb	L (1)
3	Clutch Cover Bolts (M6, L = 30 mm)	12	1.2	104 in·lb	L (1)
4	Clutch Hub Nut	135	14	100	R
5	Clutch Lever Clamp Bolts	7.8	0.80	69 in·lb	S
6	Clutch Spring Bolts	8.8	0.90	78 in·lb	
7	Oil Filler Plug	1.5	0.15	13 in·lb	
8	Sub Clutch Hub Bolts	25	2.5	18	L

CL: Apply cable lubricant.

EO: Apply engine oil.

G: Apply grease.

HG: Apply high-temperature grease.

L: Apply a non-permanent locking agent.

M: Apply molybdenum disulfide grease.

R: Replacement Parts

S: Follow the specific tightening sequence.

W: Apply water.

## 6-4 CLUTCH

### Specifications

Item	Standard	Service Limit
<b>Clutch Lever Free Play</b>	2 ~ 3 mm (0.08 ~ 0.12 in.)	— — —
<b>Clutch</b>		
Spring Plate Free Play	(Usable Range) 0.05 ~ 0.55 mm (0.002 ~ 0.022 in.)	— — —
Clutch Plate Assembly Length	39.1 mm (1.54 in.)	— — —
Friction Plate Thickness	2.72 ~ 2.88 mm (0.107 ~ 0.113 in.)	2.6 mm (0.102 in.)
Friction and Steel Plate Warp	0.15 mm (0.006 in.) or less	0.3 mm (0.012 in.)
Clutch Spring Free Length	41.6 mm (1.64 in.)	40.1 mm (1.58 in.)

**Special Tool and Sealant**

**Clutch Holder:  
57001-1243**

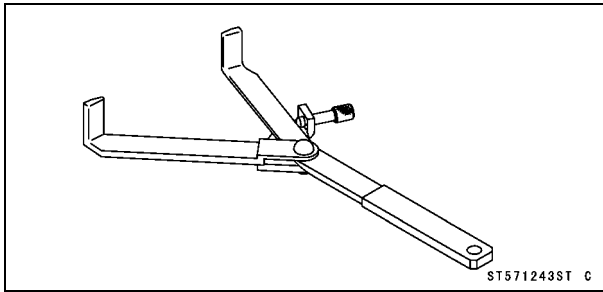

**Kawasaki Bond (Silicone Sealant):  
92104-0004**

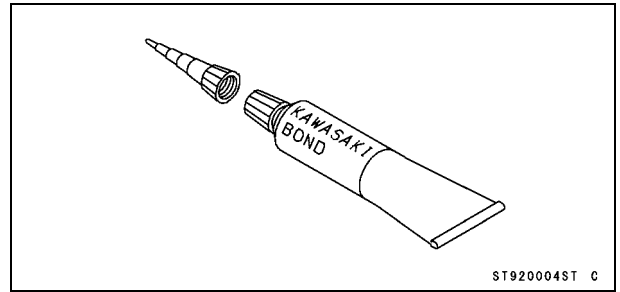

## 6-6 CLUTCH

### Clutch Lever and Cable

#### Clutch Lever Free Play Inspection

- Refer to the Clutch Operation Inspection in the Periodic Maintenance chapter.

#### Clutch Lever Free Play Adjustment

- Refer to the Clutch Operation Inspection in the Periodic Maintenance chapter.

#### Cable Removal

- Remove the right center fairing (see Center Fairing Removal in the Frame chapter).
- Slide the dust cover [A] at the clutch cable lower end out of place.
- Loosen the nuts [B], and slide the lower end of the clutch cable to give the cable plenty of play.

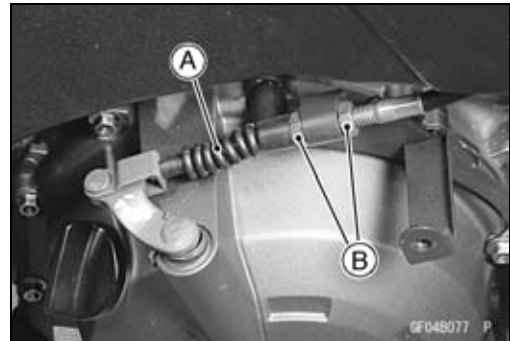

- Screw in the adjuster.
- Line up the slots [A] in the clutch lever and adjuster [B], and then free the cable from the lever.
- Free the clutch inner cable tip from the clutch release lever.
- Push the release lever toward the front of the motorcycle and tape the release lever to the clutch cover to prevent the release shaft from falling out.
- Pull the clutch cable out of the frame.

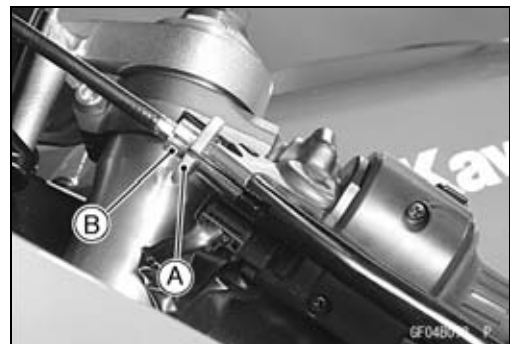

#### Cable Installation

- Run the clutch cable correctly (see Cable, Wire, and Hose Routing section in the Appendix chapter).
- Adjust the clutch cable (see Clutch Operation Inspection in the Periodic Maintenance chapter).

#### Cable Lubrication

- Refer to the Chassis Parts Lubrication in the Periodic Maintenance chapter.

#### Clutch Lever Installation

- Install the clutch lever so that the mating surface [A] of the clutch lever clamp is aligned with the mating surface [B] of the switch housing.
- Tighten the upper clamp bolt first, and then the lower clamp bolt. There will be a gap at the lower part of the clamp after tightening.

**Torque - Clutch Lever Clamp Bolts: 7.8 N·m (0.80 kgf·m, 69 in·lb)**

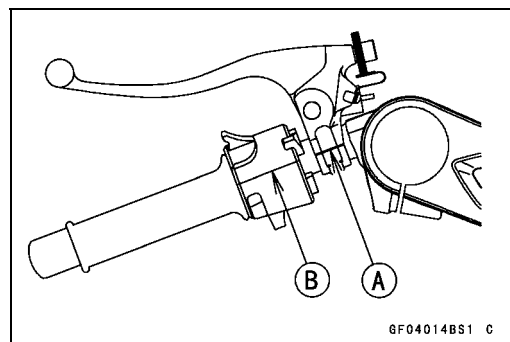

## Clutch Cover

### Clutch Cover Removal

- Remove:
  - Engine Oil (Drain, see Engine Oil Change in the Periodic Maintenance chapter)
  - Right Center Fairing (see Center Fairing Removal in the Frame chapter)
  - Clutch Cable Lower End [A]
  - Clutch Cover Bolts [B]

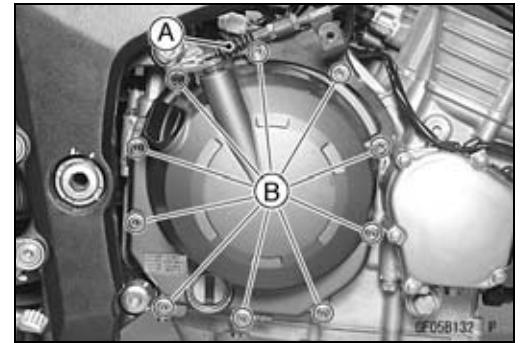

- Turn the release lever [A] toward the rear as shown, and remove the clutch cover [B].  
About 90° [C]



### Clutch Cover Installation

- Apply silicone sealant to the area [A] where the mating surface of the crankcase touches the clutch cover gasket.  
**Sealant - Kawasaki Bond (Silicone Sealant): 92104-0004**

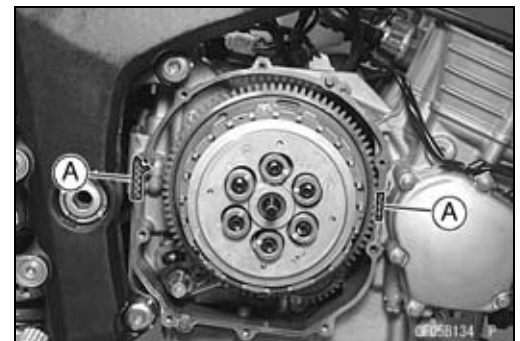

- Replace the clutch cover gasket with a new one.
- Tighten the clutch cover bolts.
- Apply a non-permanent locking agent to the threads of the clutch cover bolts.

**Torque - Clutch Cover Bolts: 12 N·m (1.2 kgf·m, 104 in·lb)**

L = 50 mm (1.97 in.) [A]

L = 40 mm (1.57 in.) [B]

L = 40 mm (1.57 in.) [C] (Apply a non-permanent locking agent.)

L = 30 mm (1.18 in.) [D] (Apply a non-permanent locking agent.)

L = 30 mm (1.18 in.) [E]

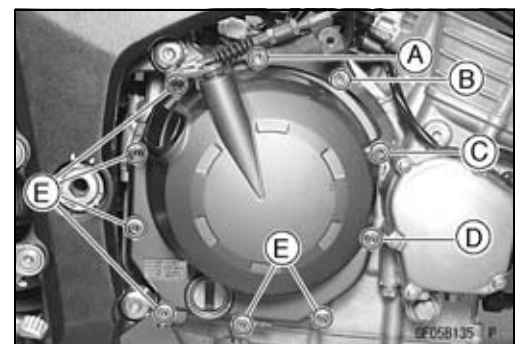

### Release Shaft Removal

#### CAUTION

**Do not remove the clutch release lever and shaft assembly unless it is absolutely necessary. If removed, the oil seal replacement may be required.**

- Remove the clutch cover (see Clutch Cover Removal in this chapter).
- Pull the lever and shaft assembly straight out of the clutch cover.

## 6-8 CLUTCH

### Clutch Cover

#### Release Shaft Installation

- Apply high-temperature grease to the oil seal lips on the upper ridge of the clutch cover.
- Apply engine oil to the needle bearings in the hole of the clutch cover.
- Apply molybdenum disulfide grease to the pusher-holding portion [A] on the release shaft.
- Install the washer [B] and spring [C].
- Insert the release shaft straight into the upper hole of the clutch cover.

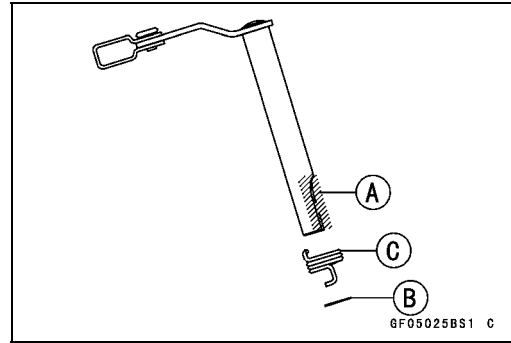

#### CAUTION

**When inserting the release shaft, be careful not to remove the spring of the oil seal.**

- Fit the spring [A] as shown.  
Viewed from Rear [B]  
Release Shaft [C]  
Clutch Cover [D]

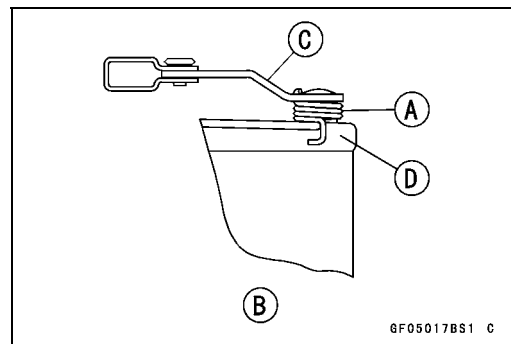

#### Clutch Cover Disassembly

- Remove:  
Oil Seal  
Needle Bearings [A]



#### Clutch Cover Assembly

- Replace the needle bearings and oil seal with new ones.

#### NOTE

○ Install the needle bearings so that the manufacture's mark face out.

- Install the needle bearings [A] and oil seal [B] as shown.
- Press the bearing, do not protrude from the boss [C] of the clutch cover.
- Press the bearing so that the bearing surface [D] is flush with the housing end of clutch cover [E].

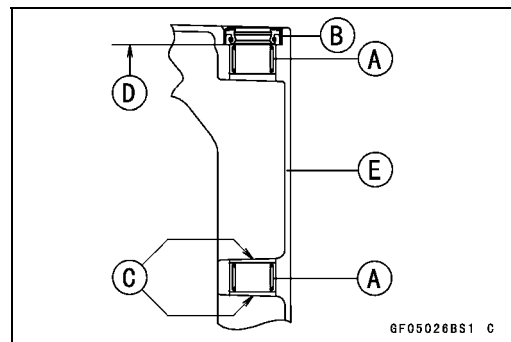

## Clutch

### Clutch Removal

- Remove:
  - Engine Oil (Drain, see Engine Oil Change in the Periodic Maintenance chapter)
  - Right Center Fairing (see Center Fairing Removal in the Frame chapter)
  - Clutch Cover (see Clutch Cover Removal in this chapter)
  - Clutch Spring Bolts [A]
  - Clutch Springs
  - Clutch Spring Plate [B] (with shim, bearing, pusher [C], spring and washer)
  
- Remove:
  - Friction Plates, Steel Plates
  - Spring, Spring Seat
  - Clutch Hub Nut [A]
- Holding the sub clutch hub [B], remove the nut.
  - Special Tool - Clutch Holder [C]: 57001-1243**
- Remove:
  - Torque Limiter Springs [D]
  - Sub Clutch Hub
  - Clutch Hub
  - Spacer
  
- Using the two 4 mm (0.16 in.) screws [A], pull out the sleeve [B], needle bearing [C] and clutch housing [D].
- Remove the spacer.

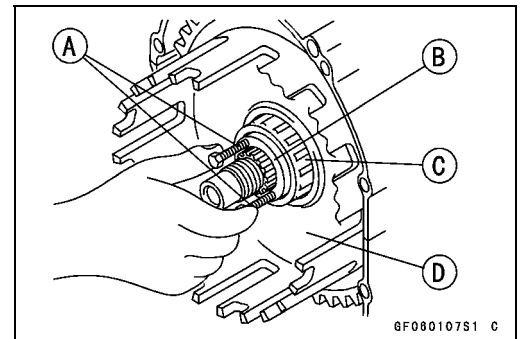
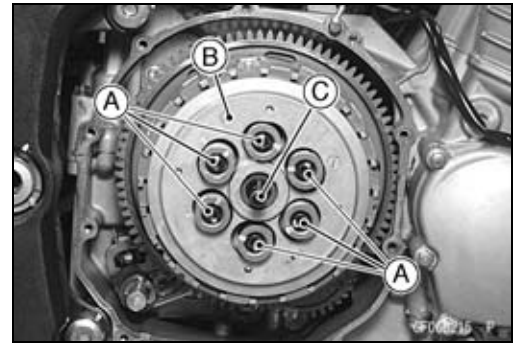

## 6-10 CLUTCH

### Clutch

#### Clutch Installation

- Install the following parts on the drive shaft.
  - Spacer [A]
  - Needle Bearing [B]
  - Sleeve [C]
  - Clutch Housing [D]
  - Spacer [E]
  - Clutch Hub [F]
  - Sub Clutch Hub [G]
  - Torque Limiter Springs [H]
  - Nut [I]

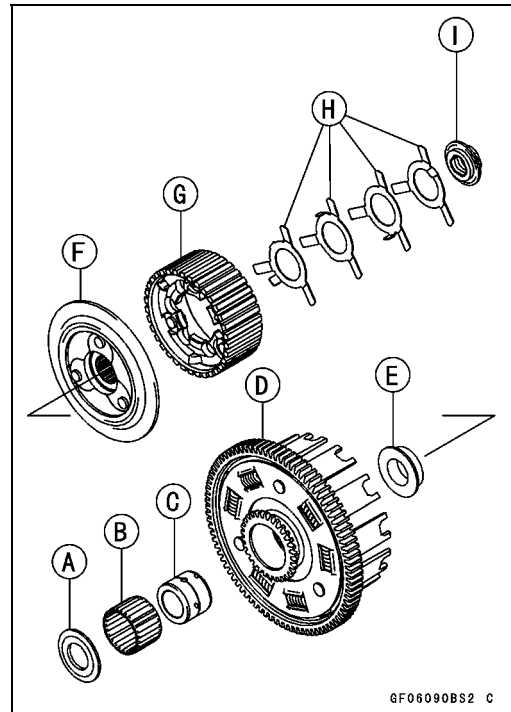

- Install the spacer [A] so that the stepped side [B] faces inward.

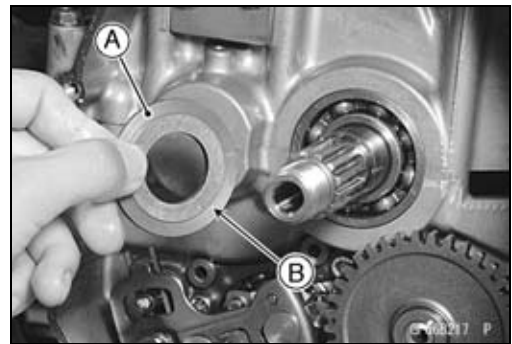

**Clutch**

- Install the clutch housing.
- If the clutch housing is replaced with a new one, select the proper clutch housing in accordance with the combination of the clutch housing gear and crankshaft markings.
  - Clutch Housing Gear [A]
  - Crankshaft [B]

**NOTE**

○ Be sure to confirm the marking on the clutch housing gear.

**Clutch Housing Gear Selection when Replacing Clutch Housing Gear**

Crankshaft Marking [C]	Clutch Housing	
	Gear Marking [D]	Part Number
A	A	13095-0044
None	None	13095-0042
B	B	13095-0045
C	C	13095-0046

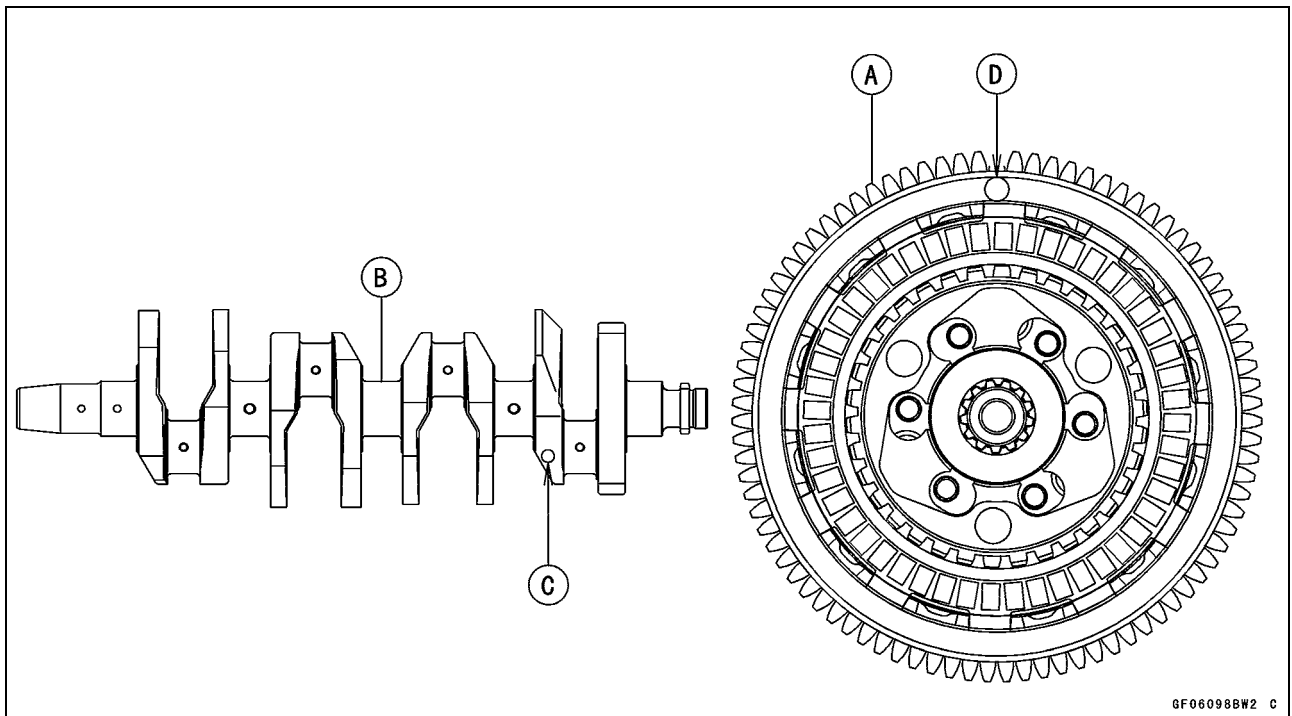

- Install the needle bearing and sleeve.

# 6-12 CLUTCH

## Clutch

- Install the spacer [A] so that the stepped side [B] faces outward.

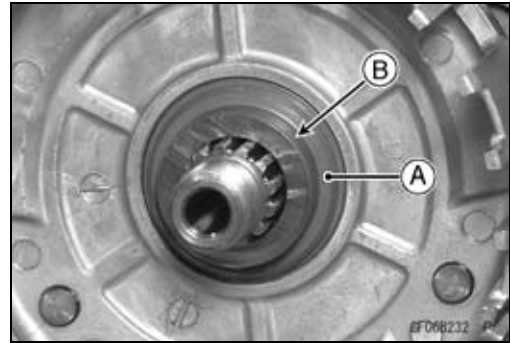

- Install the four torque limiter springs [A] as shown.
- First Torque Limiter Spring  
Tang [B]

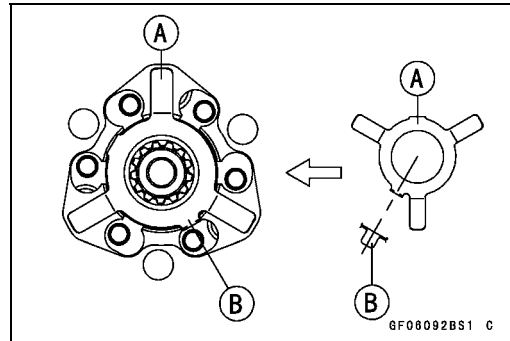

- Second Torque Limiter Spring  
Tang [B]

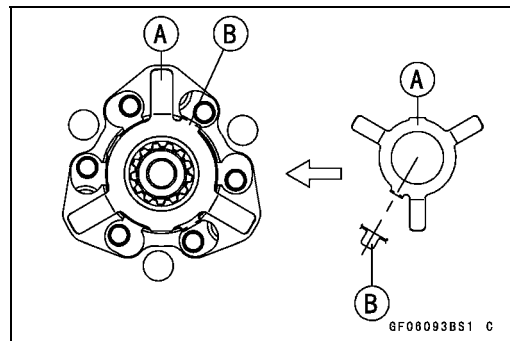

- Third Torque Limiter Spring  
Tang [B]

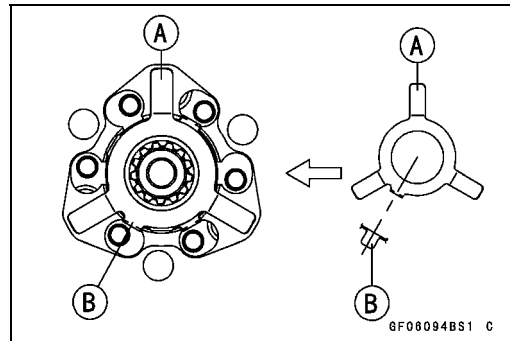

- Fourth Torque Limiter Spring  
Tang [B]

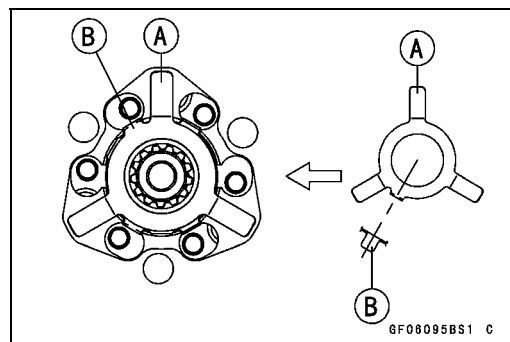

## Clutch

- Replace the clutch hub nut with a new one.
- Holding the sub clutch hub, tighten the clutch hub nut.

**Special Tool - Clutch Holder: 57001-1243**

**Torque - Clutch Hub Nut: 135 N·m (14 kgf·m, 100 ft·lb)**

- Install the friction plates and steel plates, starting with a friction plate and alternating them.

### CAUTION

**If new dry friction plates and steel plates are installed, apply engine oil to the surfaces of each plate to avoid clutch plate seizure.**

- Install the last friction plate [A] fitting the tangs in the grooves in the housing as shown.

- Apply molybdenum disulfide grease to the pusher ends [A] and install the shim [B], bearing [C], pusher [D] in the clutch spring plate [E].

Spring [F]

Washer [G]

- Align the grooves [A] of the spring plate [B] to the grooves [C] of the sub clutch hub [D] to install the spring plate on the sub clutch hub.
- Install the springs and spring holders, and tighten the clutch spring bolts.

**Torque - Clutch Spring Bolts: 8.8 N·m (0.90 kgf·m, 78 in·lb)**

- Install the clutch cover (see Clutch Cover Installation in this chapter).

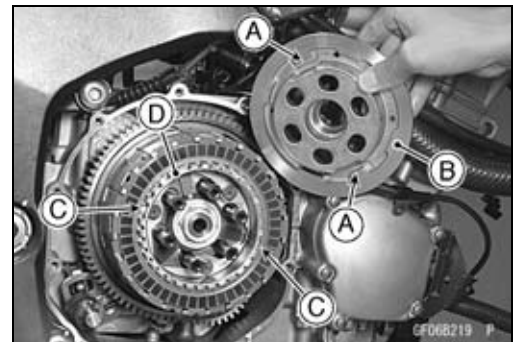
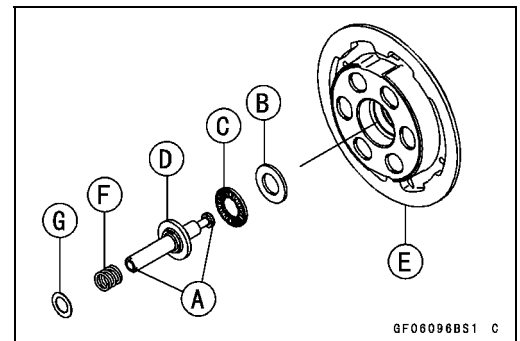

## 6-14 CLUTCH

### Clutch

#### Spring Plate Free Play Measurement

Insufficient clutch free play will cause the engine braking effect to be more sudden, resulting in rear wheel hop. On the other hand, if the free play is excessive, the clutch lever may feel “spongy” or pulsate when pulled.

- Hold an extra drive shaft in a vise and install the following clutch parts on the shaft.

- Spacer [A]
- Needle Bearing [B]
- Sleeve [C]
- Clutch Housing [D]
- Spacer [E]
- Clutch Hub [F]
- Sub Clutch Hub [G]
- Friction Plates [H]
- Steel Plates [I]
- Spring [J]
- Spring Seat [K]
- Spring Plate [L]

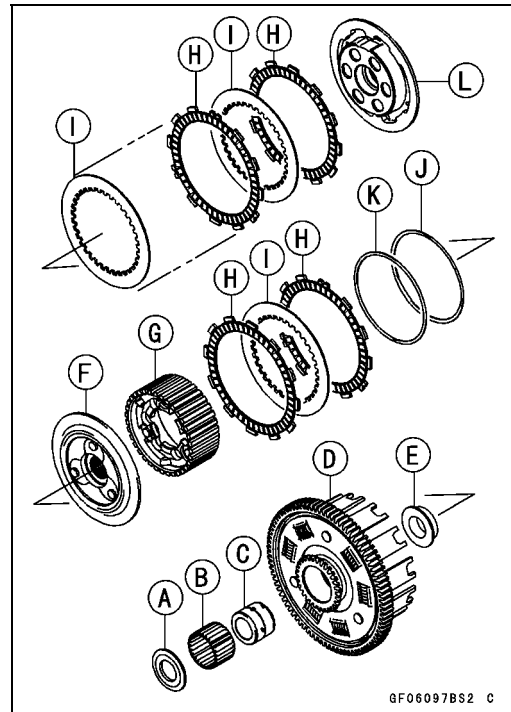

- Engage the clutch hub with the sub clutch hub.
  - To measure the free play, set a dial gauge [A] against the raised center [B] of the clutch spring plate.
  - Move the clutch housing gear back and forth [C]. The difference between the highest and lowest gauge readings is the amount of free play.
- Drive Shaft [D]
- Measure the spring plate free play.

#### Spring Plate Free Play

Usable Range: 0.05 ~ 0.55 mm (0.002 ~ 0.022 in.)

- ★ If the free play is not within the usable range, change all of the friction plate.

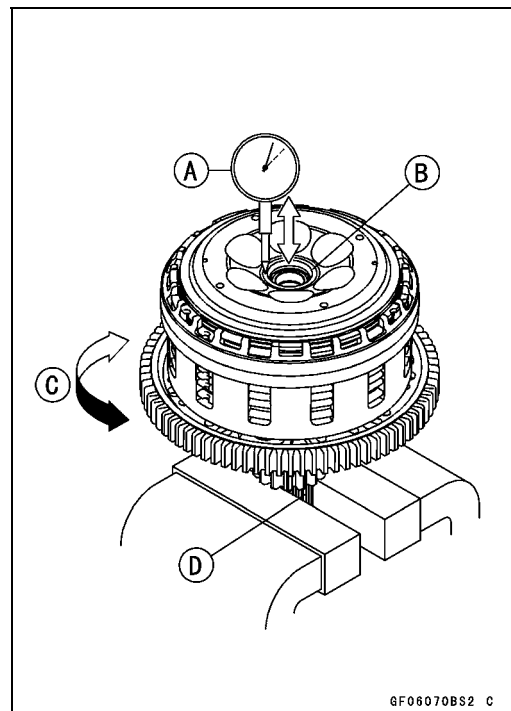

**Clutch**

**Spring Plate Play Adjustment**

- Assemble the following parts so that the clutch plate assembly length [A] is specified length.

- Clutch Hub [B]
- Spring Seat [C]
- Spring [D]
- Sub Clutch Hub [E]
- Sub Clutch Hub Bolts [F]
- Friction Plates [G]
- Steel Plates [H]
- Spring Plate [I]
- Springs [J]
- Spring Holders [K]
- Spring Bolts [L]

- Replace the following steel plate(s).

Thickness	Part Number
2.0 mm (0.079 in.)	13089-0007
2.3 mm (0.091 in.) (STD)	13089-0008
2.6 mm (0.102 in.)	13089-0009

**NOTE**

- Do not use the steel plate of 2.0 mm (0.079 in.) and 2.6 mm (0.102 in.) thickness at the same time.

**Torque - Sub Clutch Hub Bolts: 25 N·m (2.5 kgf·m, 18 ft·lb)**  
**Clutch Spring Bolts: 8.8 N·m (0.90 kgf·m, 78 in·lb)**

**Clutch Plate Assembly Length**

**Standard: 39.1 mm (1.54 in.)**

**Clutch Plate, Wear, Damage Inspection**

- Visually inspect the friction and steel plates for signs of seizure, overheating (discoloration), or uneven wear.
- Measure the thickness of each friction plate [A] at several points.
- ★ If any plates show signs of damage, or if they have worn past the service limit, replace them with new ones.

**Friction Plate Thickness**

**Standard: 2.72 ~ 2.88 mm (0.107 ~ 0.113 in.)**

**Service Limit: 2.6 mm (0.102 in.)**

**Clutch Plate Warp Inspection**

- Place each friction plate or steel plate on a surface plate and measure the gap between the surface plate [A] and each friction plate or steel plate [B] with a thickness gauge [C]. The gap is the amount of friction or steel plate warp.
- ★ If any plate is warped over the service limit, replace it with a new one.

**Friction and Steel Plate Warp**

**Standard: 0.15 mm (0.006 in.) or less**

**Service Limit: 0.3 mm (0.012 in.)**

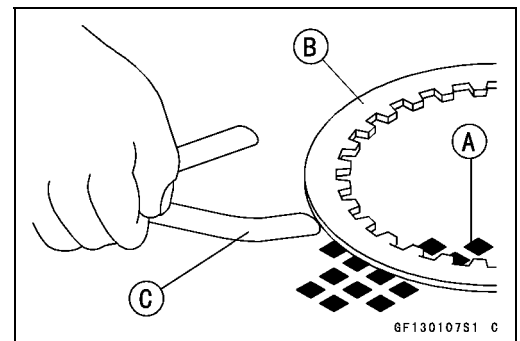
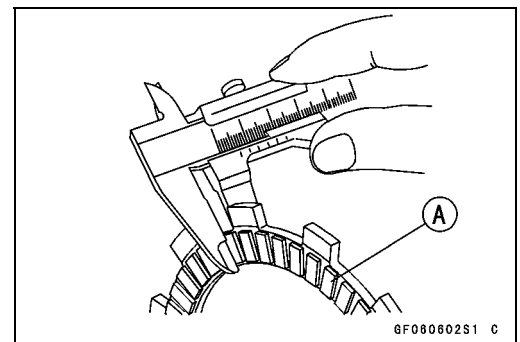
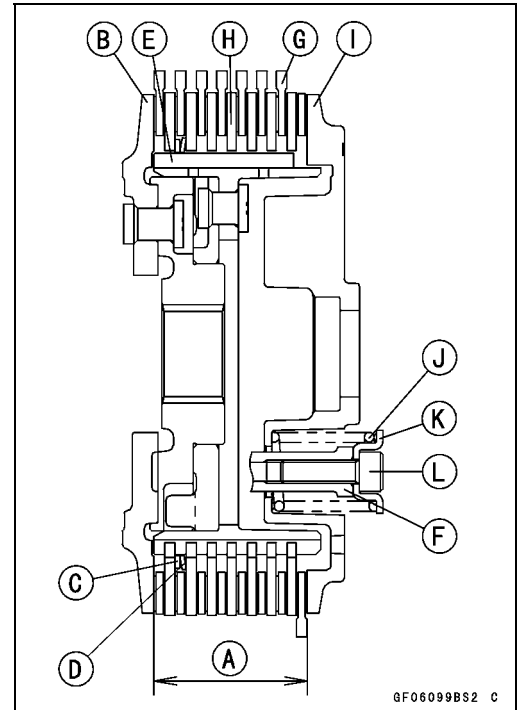

## 6-16 CLUTCH

### Clutch

#### *Clutch Spring Free Length Measurement*

- Measure the free length of the clutch springs [A].
- ★ If any spring is shorter than the service limit, it must be replaced.

#### **Clutch Spring Free Length**

**Standard:** 41.6 mm (1.64 in.)

**Service Limit:** 40.1 mm (1.58 in.)

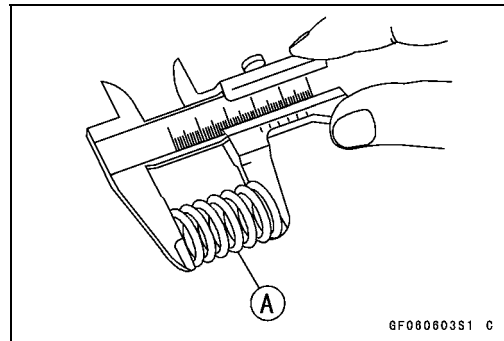

#### *Damper Cam Inspection*

- Remove the clutch (see Clutch Removal in this chapter).
- Visually inspect the damper cam [A], cam [B], and the torque limiter spring [C].
- Replace the part if it appears damaged.

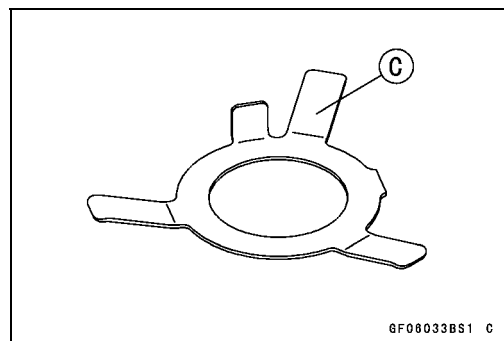
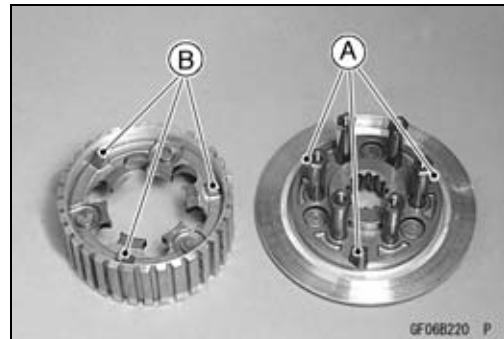

# Engine Lubrication System

## Table of Contents

Exploded View .....	7-2
Specifications .....	7-4
Special Tools and Sealant .....	7-5
Engine Oil Flow Chart.....	7-6
Engine Oil and Oil Filter.....	7-8
Oil Level Inspection.....	7-8
Engine Oil Change.....	7-8
Oil Filter Replacement .....	7-8
Oil Pan.....	7-9
Oil Pan Removal .....	7-9
Oil Pan Installation .....	7-9
Oil Pressure Relief Valve.....	7-10
Oil Pressure Relief Valve Removal .....	7-10
Oil Pressure Relief Valve Installation .....	7-10
Oil Pressure Relief Valve Inspection.....	7-10
Oil Pump.....	7-11
Oil Pump Removal .....	7-11
Oil Pump Installation .....	7-11
Oil Pump Drive Gear Removal.....	7-12
Oil Pump Drive Gear Installation.....	7-13
Oil Cooler.....	7-14
Oil Cooler Removal.....	7-14
Oil Cooler Installation.....	7-14
Oil Pressure Measurement.....	7-15
Oil Pressure Measurement .....	7-15
Oil Pressure Switch .....	7-16
Oil Pressure Switch Removal .....	7-16
Oil Pressure Switch Installation .....	7-16

# 7-2 ENGINE LUBRICATION SYSTEM

## Exploded View

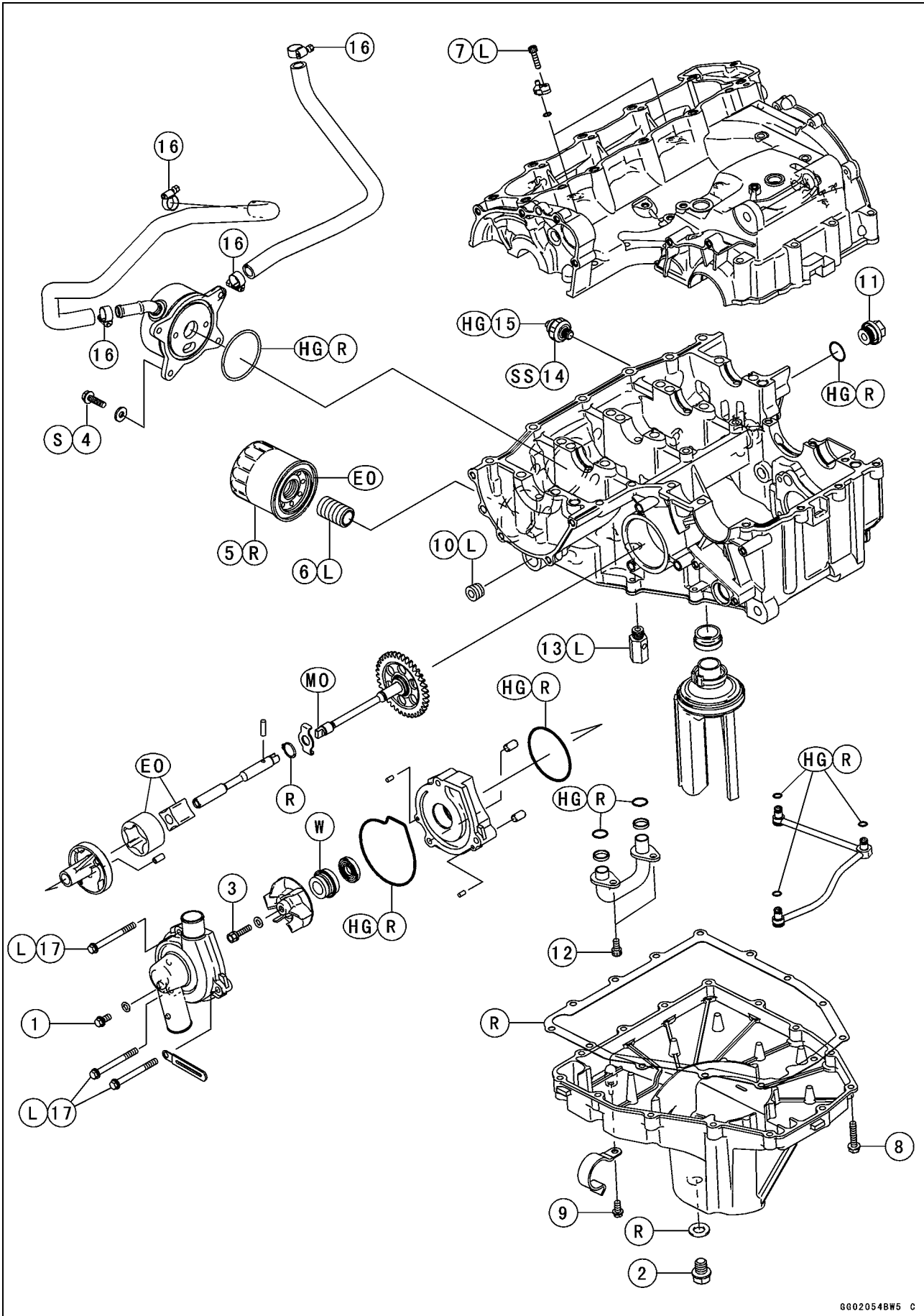

## ENGINE LUBRICATION SYSTEM 7-3

### Exploded View

No.	Fastener	Torque			Remarks
		N·m	kgf·m	ft·lb	
1	Coolant Drain Bolt (Water Pump)	8.8	0.90	78 in·lb	
2	Engine Oil Drain Bolt	29	3.0	22	
3	Impeller Bolt	9.8	1.0	87 in·lb	
4	Oil Cooler Mounting Bolts	12	1.2	104 in·lb	S
5	Oil Filter	31	3.2	23	EO, R
6	Oil Filter Mounting Bolt	25	2.5	18	L
7	Oil Jet Nozzle Bolts	6.9	0.70	61 in·lb	L
8	Oil Pan Bolts	9.8	1.0	87 in·lb	
9	Oil Pan Clamp Bolt	9.8	1.0	87 in·lb	
10	Oil Passage Plug (Left Side)	20	2.0	15	L
11	Oil Passage Plug (Right Side)	15	1.5	11	
12	Oil Pipe Bolts	12	1.2	104 in·lb	
13	Oil Pressure Relief Valve	15	1.5	11	L
14	Oil Pressure Switch	15	1.5	11	SS
15	Oil Pressure Switch Terminal Bolt	1.5	0.15	13 in·lb	
16	Water Hose Clamp Screws	2.0	0.20	17 in·lb	
17	Water Pump Cover Bolts	12	1.2	104 in·lb	L

EO: Apply engine oil.

HG: Apply high-temperature grease.

L: Apply a non-permanent locking agent.

MO: Apply molybdenum disulfide oil solution.

(mixture of the engine oil and molybdenum disulfide grease in a weight ratio 10 : 1)

R: Replacement Parts

S: Follow the specified tightening sequence.

SS: Apply silicone sealant.

W: Apply water.

## 7-4 ENGINE LUBRICATION SYSTEM

### Specifications

Item	Standard
<b>Engine Oil</b> Type Viscosity Capacity Level	API SE, SF or SG API SH or SJ with JASO MA SAE 10W-40 3.4 L (3.6 US gt) (when filter is not removed) 3.6 L (3.8 US gt) (when filter is removed) 4.0 L (4.2 US gt) (when engine is completely dry) Between upper and lower level lines
<b>Oil Pressure Measurement</b> Oil Pressure @4 000 r/min (rpm), Oil Temperature 90°C (194°F)	131 ~ 161 kPa (1.34 ~ 1.64 kgf/cm <sup>2</sup> , 19 ~ 23 psi)

## Special Tools and Sealant

**Outside Circlip Pliers:**

**57001-144**

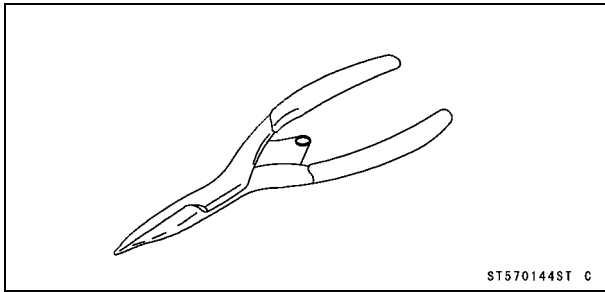

**Oil Pressure Gauge, 10 kgf/cm<sup>2</sup>:**

**57001-164**

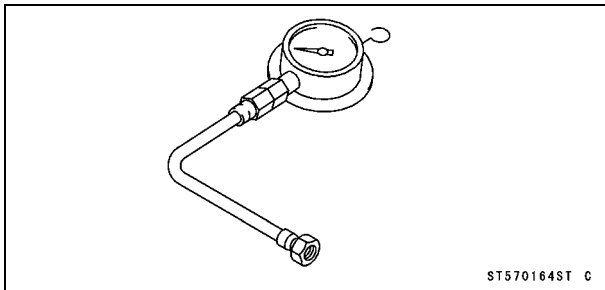

**Oil Filter Wrench:**

**57001-1249**

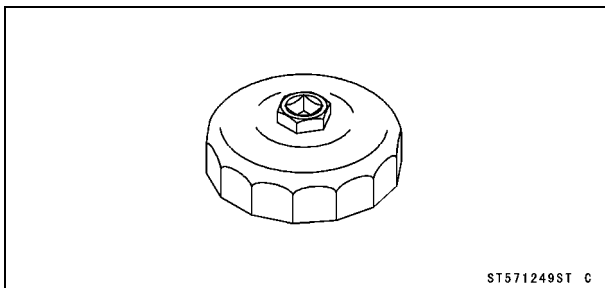

**Oil Pressure Gauge Adapter, M18 × 1.5:**

**57001-1278**

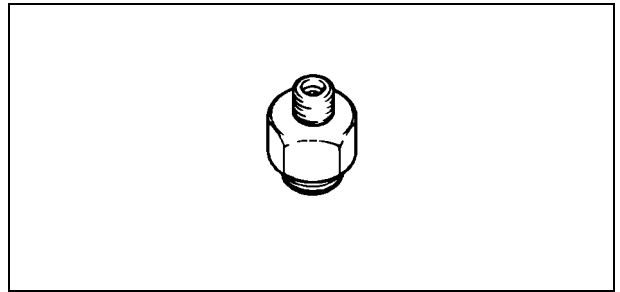

**Kawasaki Bond (Silicone Sealant):**

**56019-120**

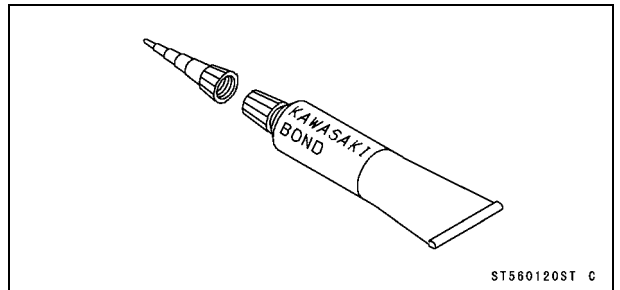

# 7-6 ENGINE LUBRICATION SYSTEM

## Engine Oil Flow Chart

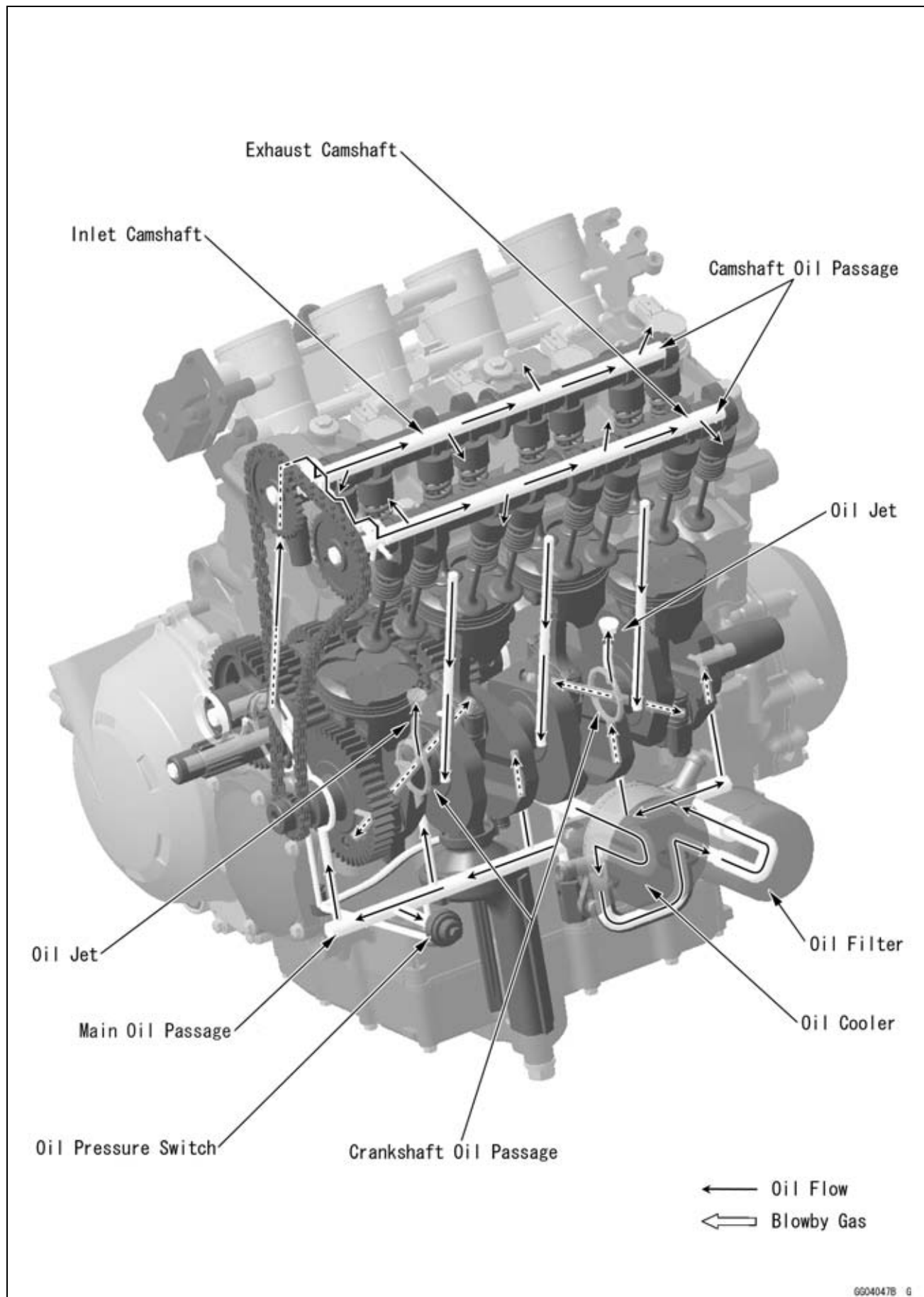

Engine Oil Flow Chart

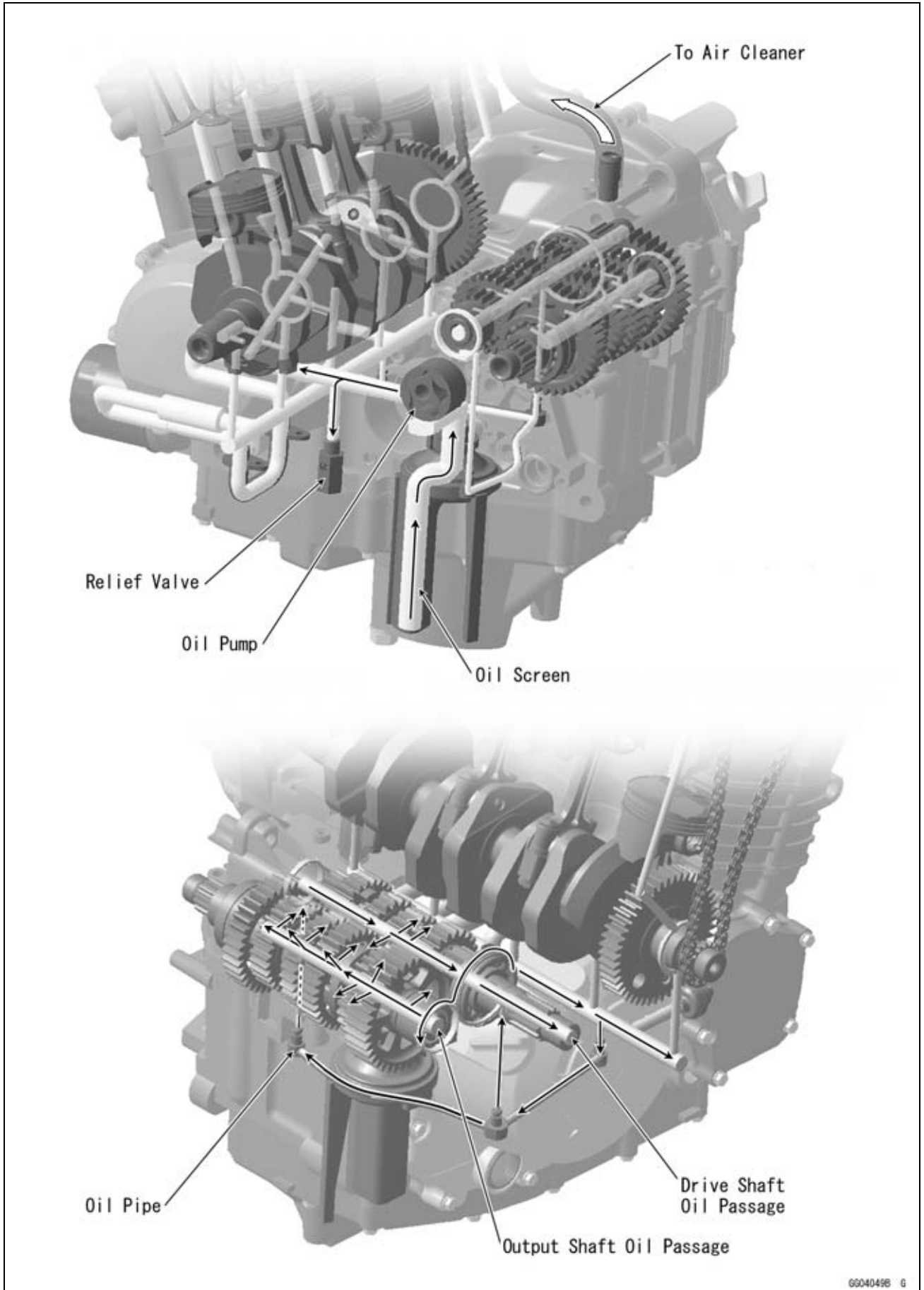

## 7-8 ENGINE LUBRICATION SYSTEM

### Engine Oil and Oil Filter

#### **⚠ WARNING**

Motorcycle operation with insufficient, deteriorated, or contaminated engine oil will cause accelerated wear and may result in engine or transmission seizure, accident, and injury.

#### *Oil Level Inspection*

- Check that the engine oil level is between the upper [A] and lower [B] levels in the gauge.

#### **NOTE**

- Situate the motorcycle so that it is perpendicular to the ground.
- If the motorcycle has just been used, wait several minutes for all the oil to drain down.
- If the oil has just been changed, start the engine and run it for several minutes at idle speed. This fills the oil filter with oil. Stop the engine, then wait several minutes until the oil settles.

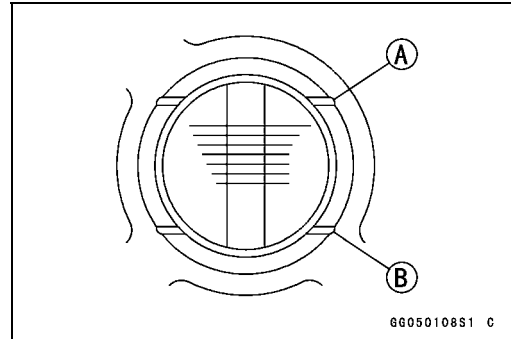

#### **CAUTION**

Racing the engine before the oil reaches every part can cause engine seizure.

If the engine oil gets extremely low or if the oil pump or oil passages clog up or otherwise do not function properly, the oil pressure warning light will light. If this light stays on when the engine is running above idle speed, stop the engine immediately and find the cause.

- ★ If the oil level is too high, remove the excess oil, using a syringe or some other suitable device.
- ★ If the oil level is too low, add the correct amount of oil through the oil filler opening. Use the same type and make of oil that is already in the engine.

#### **NOTE**

- If the engine oil type and make are unknown, use any brand of the specified oil to top off the level in preference to running the engine with the oil level low. Then at your earliest convenience, change the oil completely.

#### *Engine Oil Change*

- Refer to the Engine Oil Change in the Periodic Maintenance chapter.

#### *Oil Filter Replacement*

- Refer to the Oil Filter Replacement in the Periodic Maintenance chapter.

## Oil Pan

### Oil Pan Removal

- Remove:
    - Engine Oil (Drain, see Engine Oil Change in the Periodic Maintenance chapter)
    - Exhaust Pipe (see Exhaust Pipe Removal in the Engine Top End chapter)
  - Remove the water hose from the oil pan clamp.
  - Remove:
    - Oil Pan Bolts [A]
    - Oil Pan [B]
- Remove the oil screen, oil pipe and oil pressure relief valve [A] as necessary.

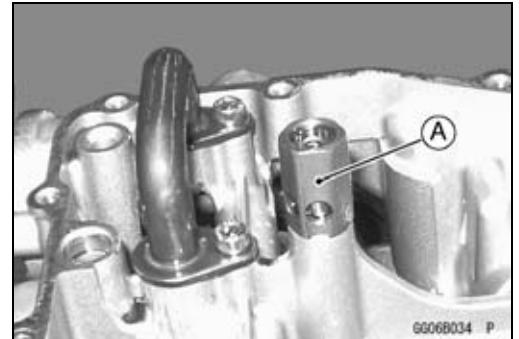
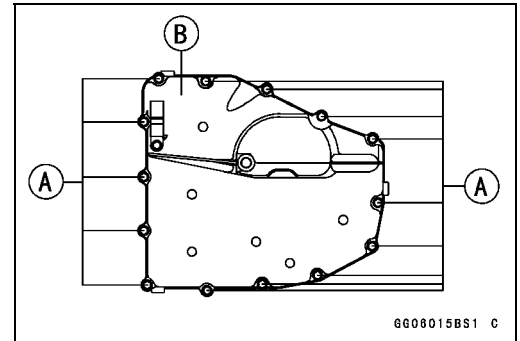

### Oil Pan Installation

- Clean the oil screen [A].
- Install the oil screen so that the crankcase rib [B] fits the slot of the oil screen.

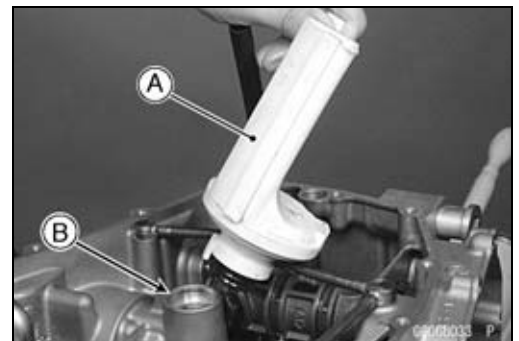

- ★ If the oil pressure relief valve [A] was removed, install it.
- Apply a non-permanent locking agent to the threads of the oil pressure relief valve, and tighten it.

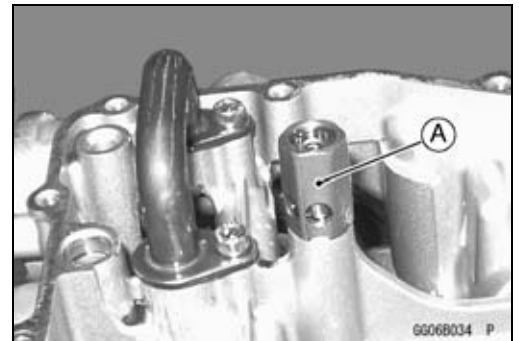

### CAUTION

**Do not apply too much non-permanent locking agent to the threads. This may block the oil passage.**

**Torque - Oil Pressure Relief Valve: 15 N·m (1.5 kgf·m, 11 ft·lb)**

- Install the clamp [A] as shown.  
Boss [B]
- Replace the oil pan gasket with a new one.
- Tighten:
  - Torque - Oil Pan Bolts [C] : 9.8 N·m (1.0 kgf·m, 87 in·lb)**

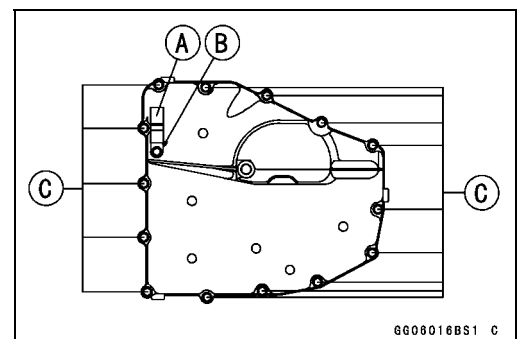

## 7-10 ENGINE LUBRICATION SYSTEM

### Oil Pressure Relief Valve

#### *Oil Pressure Relief Valve Removal*

- See Oil Pan Removal in this chapter.

#### *Oil Pressure Relief Valve Installation*

- See Oil Pan Installation in this chapter.

#### *Oil Pressure Relief Valve Inspection*

- Check to see if the valve [A] slides smoothly when pushing it in with a wooden or other soft rod, and see if it comes back to its seat by spring [B] pressure.

#### **NOTE**

○ *Inspect the valve in its assembled state. Disassembly and assembly may change the valve performance.*

- ★ If any rough spots are found during above inspection, wash the valve clean with a high-flash point solvent and blow out any foreign particles that may be in the valve with compressed air.

#### **⚠ WARNING**

**Clean the oil pressure relief valve in a well-ventilated area, and take care that there is no spark or flame anywhere near the working area. Because of the danger of highly flammable liquids, do not use gasoline or low-flash point solvent.**

- ★ If cleaning does not solve the problem, replace the oil pressure relief valve as an assembly. The oil pressure relief valve is precision made with no allowance for replacement of individual parts.

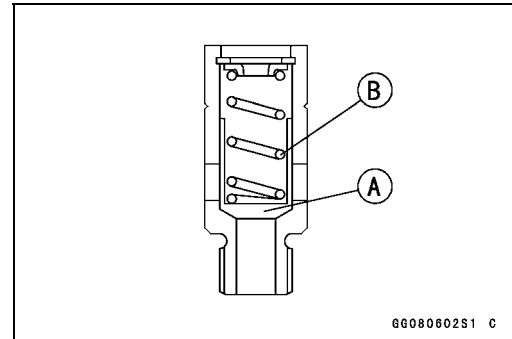

## Oil Pump

### Oil Pump Removal

- Drain:
  - Coolant (see Coolant Change in the Periodic Maintenance chapter)
  - Engine Oil (see Engine Oil Change in the Periodic Maintenance chapter)

- Remove:
  - Water Hoses [A]
  - Water Pump Cover Bolts [B]
  - Water Pump Cover

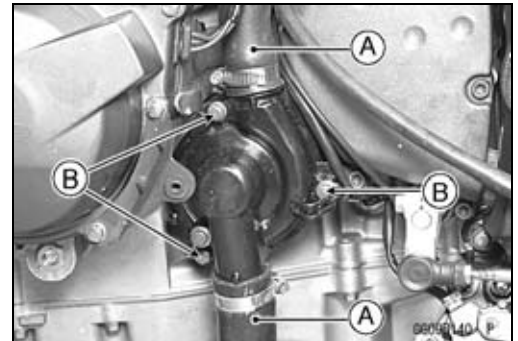

- Remove:
  - Impeller Bolt [A]
  - Washer
  - Impeller [B]

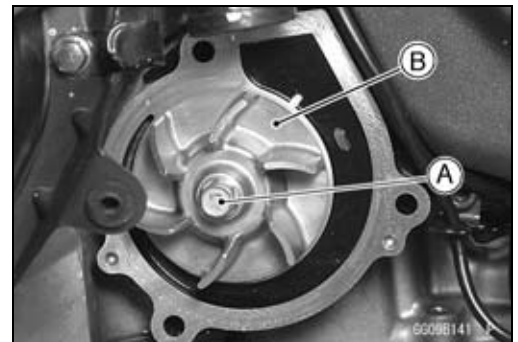

- Remove:
  - Water Pump Body
  - Oil Pump Cover
  - Oil (Water) Pump Shaft
  - Outer Rotor [A] and Inner Rotor [B]

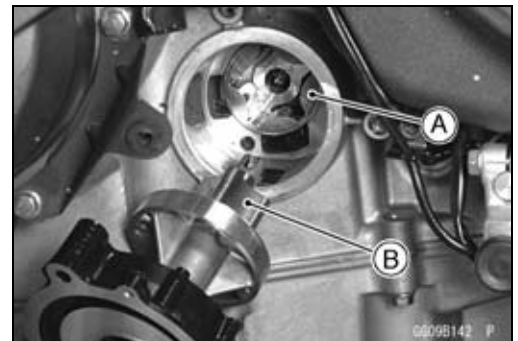

### NOTE

- *The oil (water) pump assembly can easily be removed by installing impeller bolt into the oil (water) pump shaft and pulling them.*

### Oil Pump Installation

- Install the outer rotor [A] into the crankcase.
- Install the pin [B] and inner rotor [C] to the oil (water) pump shaft [D], and install the assy.
- Turn the pump shaft so that the slot [E] in its shaft fits onto the projection [F] of the pump drive gear shaft.

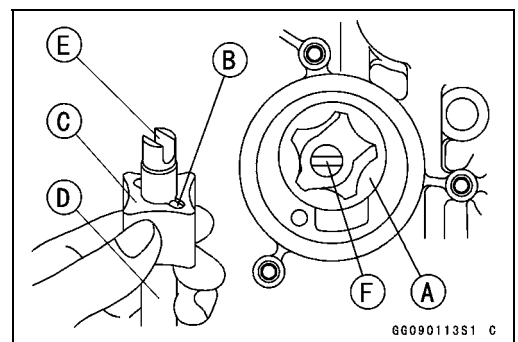

# 7-12 ENGINE LUBRICATION SYSTEM

## Oil Pump

- Fit the pin [A] of the oil pump cover [B] into the hole [C] in the crankcase.

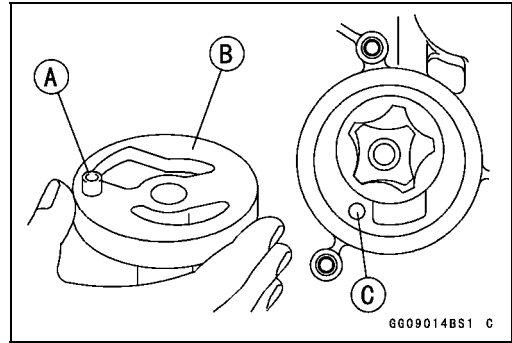

- Install:
  - Pins [A]
  - Water Pump Body [B]

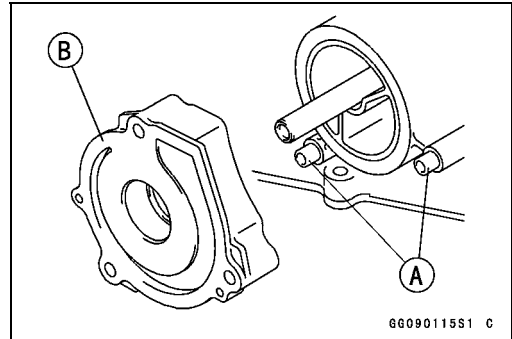

- Apply coolant to the surface of the rubber seal on the impeller.
- Install the impeller [A], washer and impeller bolt [B].  
**Torque - Impeller Bolt: 9.8 N·m (1.0 kgf·m, 87 in·lb)**
  - Pins [C]
  - Water Pump Cover [D]
- Apply a non-permanent locking agent to the threads of the water pump cover bolts, and tighten them.  
**Torque - Water Pump Cover Bolts: 12 N·m (1.2 kgf·m, 104 in·lb)**

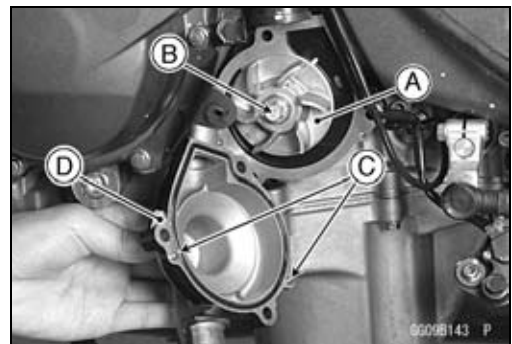

- Align the line [A] of water pump cover and white mark [B] of water hose.
- Tighten:  
**Torque - Water Hose Clamp Screw: 2.0 N·m (0.20 kgf·m, 17 in·lb)**
- Route the each hoses and leads correctly (see Cable, Wire, and Hose Routing section in the Appendix chapter).

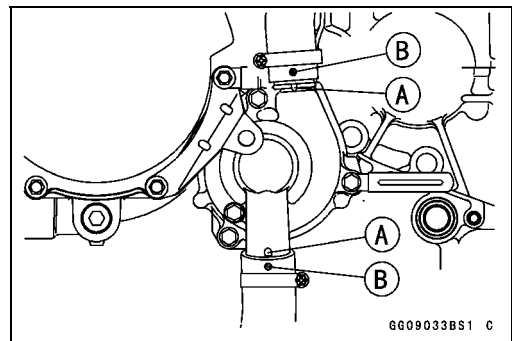

### Oil Pump Drive Gear Removal

- Remove:
    - Clutch (see Clutch Removal in the Clutch chapter)
    - Oil Pan (see Oil Pan Removal in this chapter)
    - Circlip [A] and washer [B]
- Special Tool - Outside Circlip Pliers: 57001-144**

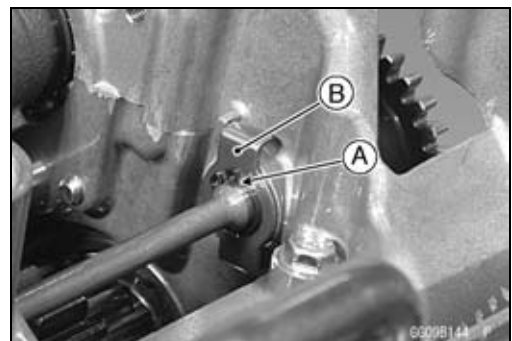

## Oil Pump

- Pull the oil pump drive gear [A].

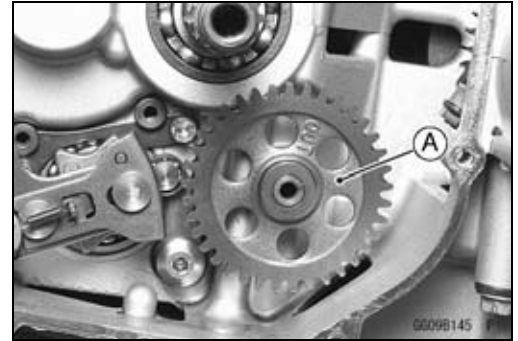

### *Oil Pump Drive Gear Installation*

- Apply molybdenum disulfide oil solution to the journal portions [A] on the oil pump drive gear shaft [B].
- Install:  
Washer [C]

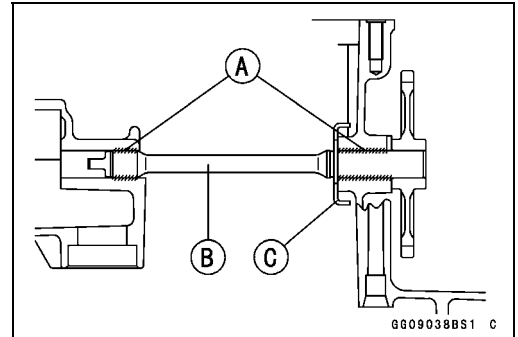

- Install the new circlip [A] into the groove of the oil pump drive gear shaft.

**Special Tool - Outside Circlip Pliers: 57001-144**

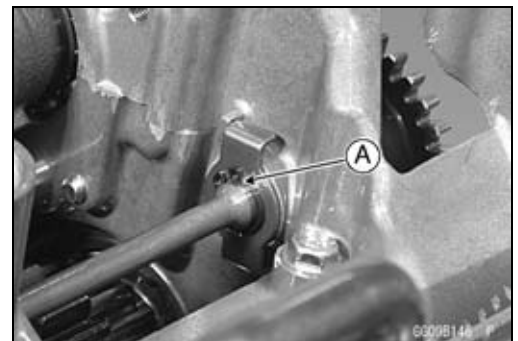

## 7-14 ENGINE LUBRICATION SYSTEM

### Oil Cooler

#### Oil Cooler Removal

- Remove:
  - Lower Fairings (see Lower Fairing Removal in the Frame chapter)
- Drain:
  - Coolant (see Coolant Change in the Periodic Maintenance chapter)
  - Engine Oil (see Engine Oil Change in the Periodic Maintenance chapter)
- Remove the water hoses [A] from the oil cooler.
- Remove the oil cooler mounting bolts [B], and remove the oil cooler [C].

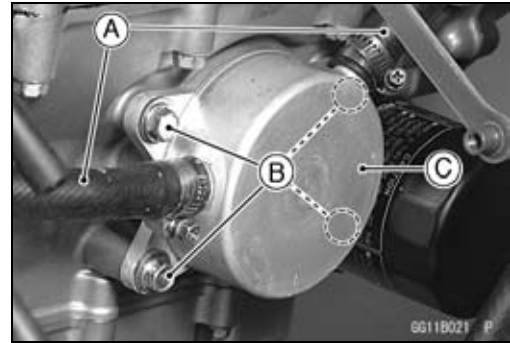

#### Oil Cooler Installation

- Apply high-temperature grease to the O-ring [A] before installation.

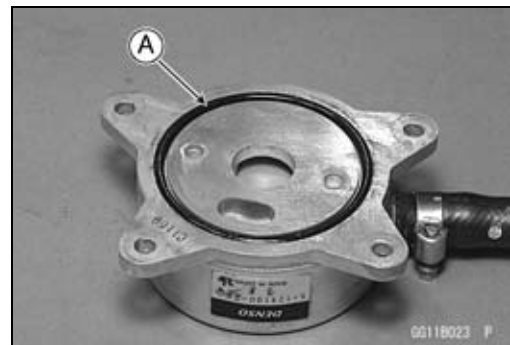

- Install the oil cooler to the crankcase, and tighten the bolts as shown sequence in the figure.

#### Torque - Oil Cooler Mounting Bolts:

First: 7.8 N·m (0.80 kgf·m, 69 in·lb)

Final: 12 N·m (1.2 kgf·m, 104 in·lb)

- Install the water hose so that the white mark [A] faces front as shown.
- Tighten:

**Torque - Water Hose Clamp Screws: 2.0 N·m (0.20 kgf·m, 17 in·lb)**

- Pour:
  - Engine Oil (see Engine Oil Change in the Periodic Maintenance chapter)
  - Coolant (see Coolant Change in the Periodic Maintenance chapter)

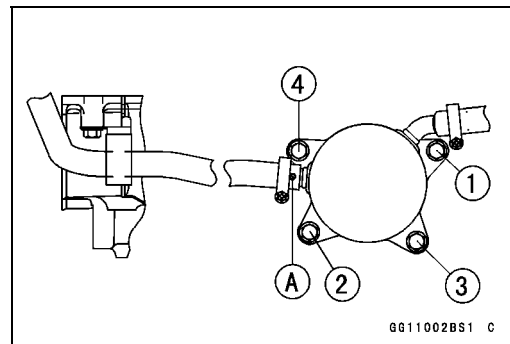

## Oil Pressure Measurement

### Oil Pressure Measurement

- Remove the lower fairings (see Lower Fairing Removal in the Frame chapter).
- Remove the oil passage plug, and attach the adapter [A] and gauge [B] to the plug hole.

**Special Tools - Oil Pressure Gauge, 10 kgf/cm<sup>2</sup>: 57001-164**  
**Oil Pressure Gauge Adapter, M18 × 1.5:**  
**57001-1278**

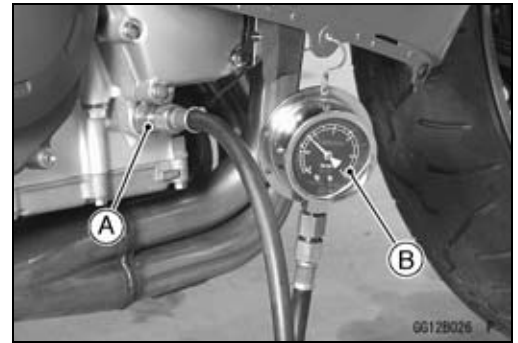

- Start the engine and warm up the engine.
- Run the engine at the specified speed, and read the oil pressure gauge.
- ★ If the oil pressure is much lower than the standard, check the oil pump, relief valve, and/or crankshaft bearing insert wear.
- ★ If the reading is much higher than the standard, check the oil passages for clogging.

### Oil Pressure

**Standard:** 131 ~ 161 kPa (1.34 ~ 1.64 kgf/cm<sup>2</sup>,  
 19 ~ 23 psi) @4 000 r/min (rpm), oil  
 temperature 90°C (194°F)

- Stop the engine.
- Remove the oil pressure gauge and adapter.

### **⚠ WARNING**

**Take care against burns from hot engine oil that will drain through the oil passage when the gauge adapter is removed.**

- Install the oil passage plug.
- Torque - Oil Passage Plug (Right Side) : 15 N·m (1.5 kgf·m,  
 11 ft·lb)**

## 7-16 ENGINE LUBRICATION SYSTEM

### Oil Pressure Switch

#### *Oil Pressure Switch Removal*

- Remove:
  - Lower Fairings (see Lower Fairing Removal in the Frame chapter)
  - Engine Oil (Drain, see Engine Oil Change in the Periodic Maintenance chapter)
  - Switch Cover [A]
  - Switch Terminal [B]
  - Oil Pressure Switch [C]

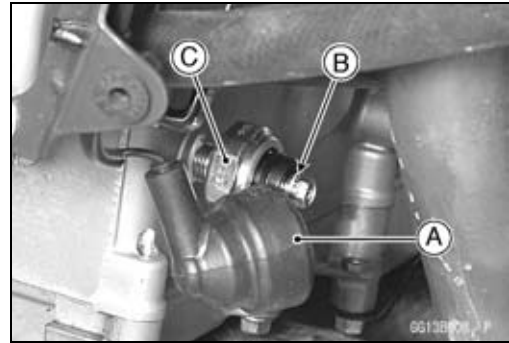

#### *Oil Pressure Switch Installation*

- Apply silicone sealant to the threads of the oil pressure switch and tighten it.
  - Sealant - Kawasaki Bond (Silicone Sealant): 56019-120**
  - Torque - Oil Pressure Switch: 15 N·m (1.5 kgf·m, 11 ft·lb)**
- Install the switch lead direction outward.
  - Outside of Engine [A]
- Apply high-temperature grease to the terminal.
- Tighten the terminal bolt.
  - Torque - Oil Pressure Switch Terminal Bolt: 1.5 N·m (0.15 kgf·m, 13 in·lb)**

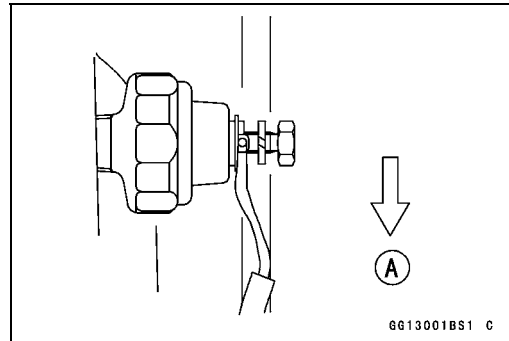

# Engine Removal/Installation

## Table of Contents

Exploded View .....	8-2
Special Tool .....	8-4
Engine Removal/Installation .....	8-5
Engine Removal.....	8-5
Engine Installation.....	8-7

## 8-2 ENGINE REMOVAL/INSTALLATION

### Exploded View

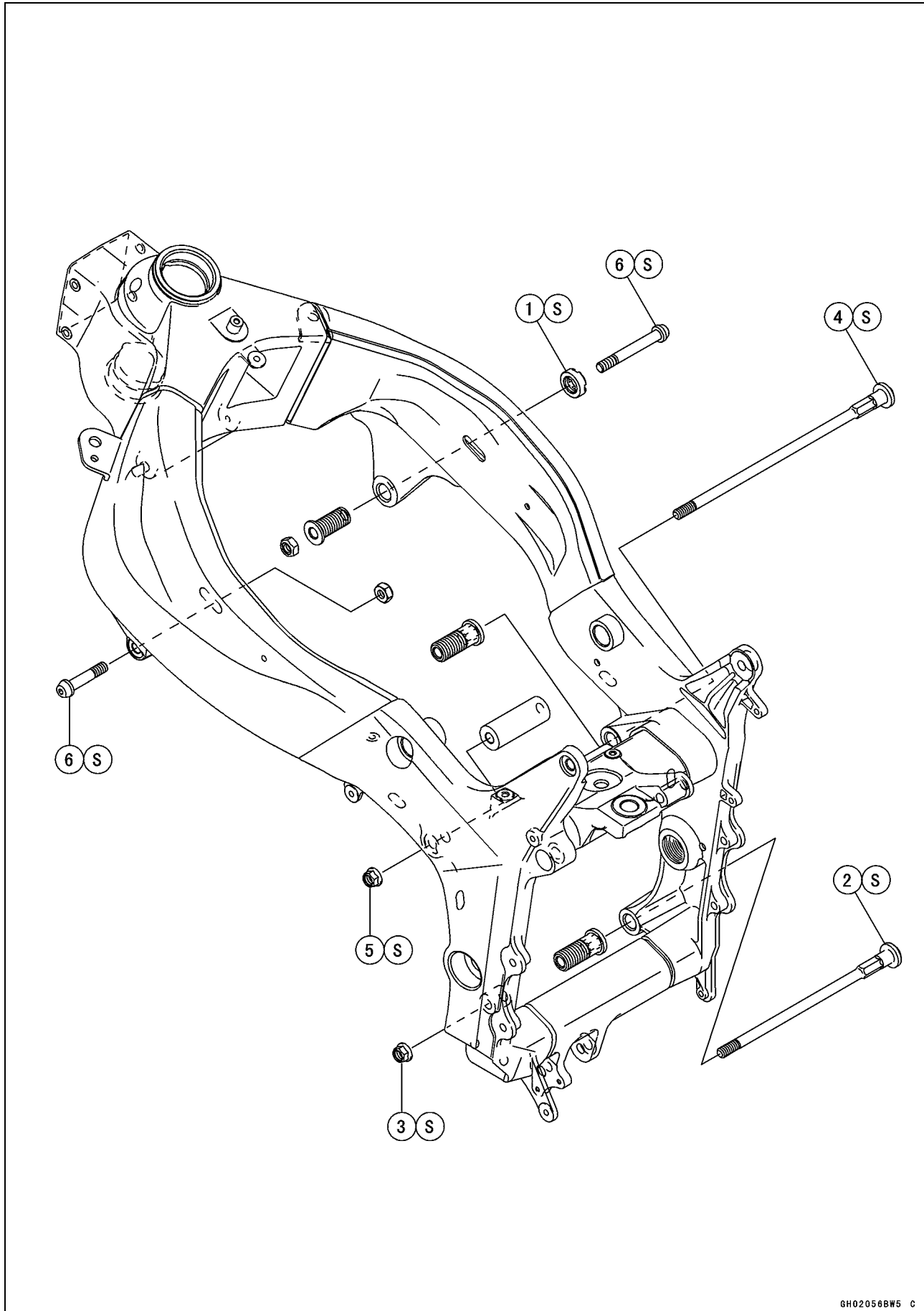

## ENGINE REMOVAL/INSTALLATION 8-3

### Exploded View

No.	Fastener	Torque			Remarks
		N·m	kgf·m	ft·lb	
1	Adjusting Collar Locknut	49	5.0	36	S
2	Lower Engine Mounting Bolt	10	1.0	87 in·lb	S
3	Lower Engine Mounting Nut	44	4.5	33	S
4	Middle Engine Mounting Bolt	10	1.0	87 in·lb	S
5	Middle Engine Mounting Nut	44	4.5	33	S
6	Upper Engine Mounting Bolts	44	4.5	33	S

S: Follow the specific tightening sequence.

## 8-4 ENGINE REMOVAL/INSTALLATION

---

### Special Tool

---

Engine Mount Nut Wrench:

57001-1450

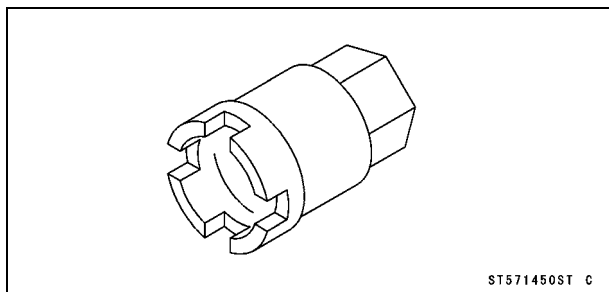

## Engine Removal/Installation

### Engine Removal

- Support the rear part of the swingarm with a stand.
- Squeeze the brake lever slowly and hold it with a band [A].

### **⚠ WARNING**

**Be sure to hold the front brake when removing the engine, or the motorcycle may fall over. It could cause an accident and injury.**

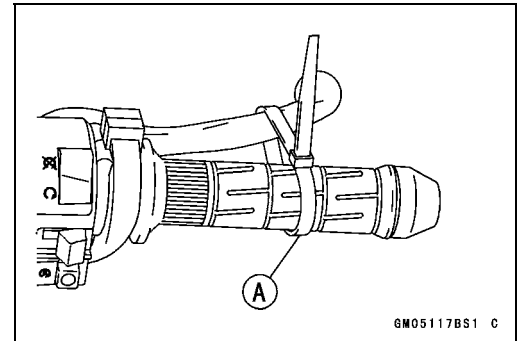

### **CAUTION**

**Be sure to hold the front brake when removing the engine, or the motorcycle may fall over. The engine or the motorcycle could be damaged.**

- Drain:
  - Engine Oil (see Engine Oil Change in the Periodic Maintenance chapter)
  - Coolant (see Coolant Change in the Periodic Maintenance chapter)
- Remove:
  - Right and Left Center Fairings (see Center Fairing Removal in the Frame chapter)
  - Fuel Tank (see Fuel Tank Removal in the Fuel System (DFI) chapter)
  - Air Cleaner Housing (see Air Cleaner Housing Removal in the Fuel System (DFI) chapter)
  - Throttle Body Assy (see Throttle Body Assy Removal in the Fuel System (DFI) chapter)
  - Clutch Cable Lower End (see Clutch Cable Removal in the Clutch chapter)
  - Radiator (see Radiator and Radiator Fan Removal in the Cooling System chapter)
  - Exhaust Pipe (see Exhaust Pipe Removal in the Engine Top End chapter)
  - Shift Lever (see Shift Pedal Removal in the Crankshaft/Transmission chapter)
  - Engine Sprocket (see Engine Sprocket Removal in the Final Drive chapter)
  - Coolant Reserve Tank (see Coolant Reserve Tank Removal in the Cooling System chapter)
- Pull off the connectors from the engine and free the wiring from the clamps.
- Remove:
  - Engine Ground Cable Terminal Bolt [A]
  - Starter Motor Lead [B]
  - Connectors [C]
  - Stick Coil Harness Connector (see Stick Coil (Ignition Coil together with Spark Plug Cap) Removal in the Electrical System chapter)

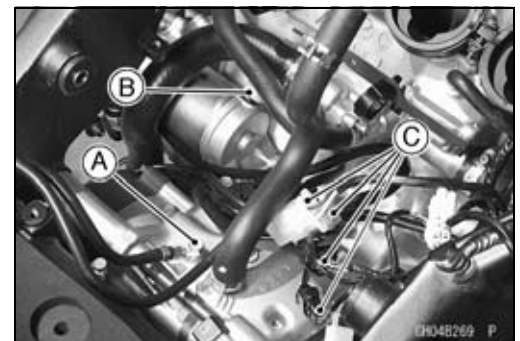

## 8-6 ENGINE REMOVAL/INSTALLATION

### Engine Removal/Installation

- Support the engine with a suitable stand [A].
- Put a plank [B] onto the suitable stand for engine balance.



- Remove:
  - Right and Left Upper Engine Mounting Bolts [A]



- Using the nut wrench [A], loosen the locknut [B].  
**Special Tool - Engine Mount Nut Wrench: 57001-1450**

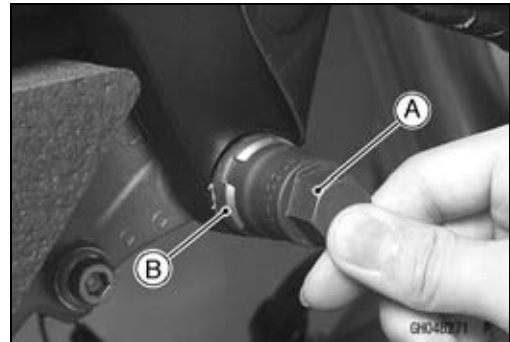

- Using the Hexagon Wrench, turn the adjusting collar [A] counterclockwise to make the gap between the engine and collar.



- Remove the middle and lower engine mounting nuts.
- Turn the middle and lower mounting bolts [A] clockwise to make the gap between the collar and frame.
- Pull out the engine mounting bolts from the right side.

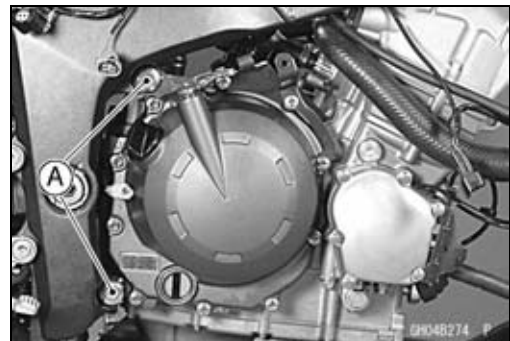

- Remove the drive chain from the output shaft.
- Using the stand, take out the engine.

### Engine Removal/Installation

#### *Engine Installation*

- Support the engine with a suitable stand.
- Put a plank onto the suitable stand for engine balance.
  
- Install the engine mounting bolts and nuts, following the specified installing sequence.
- First, install the adjusting collars [A] to crankcase back-side upper, lower and frame.
- Second, hang the drive chain over the output shaft just before moving the engine into its final position in the frame.

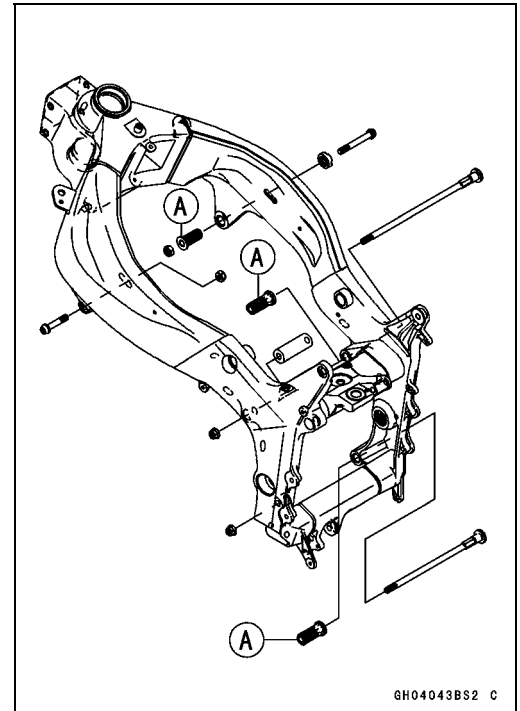

## 8-8 ENGINE REMOVAL/INSTALLATION

---

### Engine Removal/Installation

---

- Third, install the bolts [A] [B] [C] [D] temporarily.
- Fourth, install the lower [A] and middle [B] engine mounting bolts, and tighten the bolts counterclockwise.

#### NOTE

- Tighten the bolts until the clearance between the engine and collar come to 0 mm (0 in.).*

**Torque - Lower Engine Mounting Bolt: 10 N·m (1.0 kgf·m, 87 in·lb)**

**Middle Engine Mounting Bolt: 10 N·m (1.0 kgf·m, 87 in·lb)**

- Fifth, tighten the left upper engine mounting bolt [D].
- Sixth, tighten the lower [E] and middle [F] engine mounting nuts.
- Seventh, pull out bolt [C] temporarily, and tighten the adjusting collar [G] counterclockwise until the clearance [H] between the cylinder head and collar come to 0 mm (0 in.).
- Eighth, tighten the right upper engine mounting bolt.
- Ninth, tighten the adjusting collar locknut [I].

**Special Tool - Engine Mount Nut Wrench: 57001-1450**

- Lastly, tighten the bolts and nuts following the tightening sequence [1 ~ 5] as shown.

**Torque - Left Upper Engine Mounting Bolt [D]: 44 N·m (4.5 kgf·m, 33 ft·lb)**

**Lower Engine Mounting Nut [E]: 44 N·m (4.5 kgf·m, 33 ft·lb)**

**Middle Engine Mounting Nut [F]: 44 N·m (4.5 kgf·m, 33 ft·lb)**

**Right Upper Engine Mounting Bolt [C]: 44 N·m (4.5 kgf·m, 33 ft·lb)**

**Adjusting Collar Locknut [I]: 49 N·m (5.0 kgf·m, 36 ft·lb)**

## Engine Removal/Installation

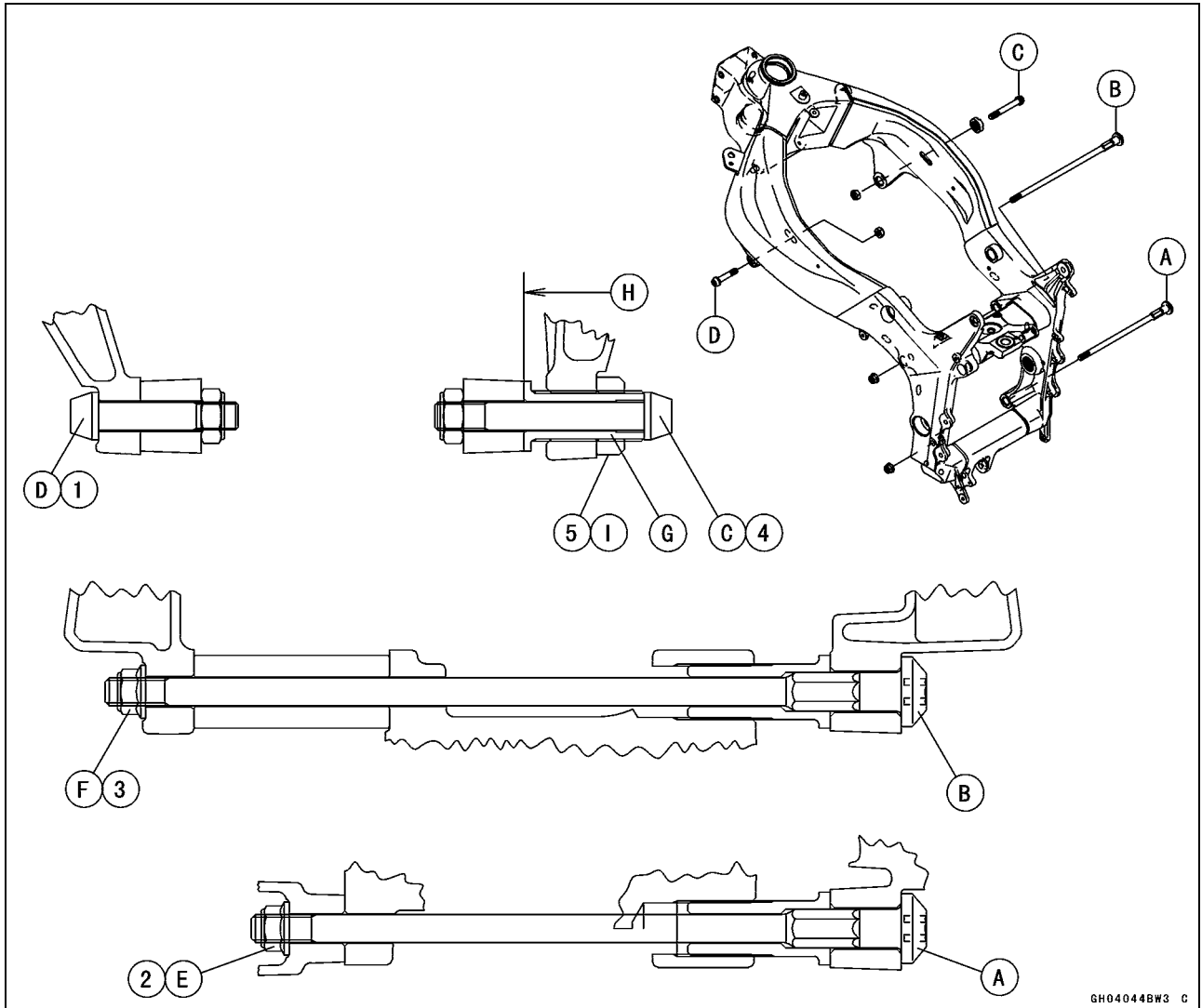

- Run the leads, cable and hoses correctly (see Cable, Wire, and Hose Routing section in the Appendix chapter).
- Install the removed parts (see appropriate chapters).
- Adjust:
  - Throttle Cables (see Throttle Control System Inspection in the Periodic Maintenance chapter)
  - Clutch Cable (see Clutch Operation Inspection in the Periodic Maintenance chapter)
  - Drive Chain (see Drive Chain Slack Inspection in the Periodic Maintenance chapter)
- Fill the engine with engine oil (see Engine Oil Change in the Periodic Maintenance chapter).
- Fill the engine with coolant and bleed the air from the cooling system (see Coolant Change in the Periodic Maintenance chapter).



# Crankshaft/Transmission

## Table of Contents

Exploded View .....	9-2
Specifications .....	9-6
Special Tools and Sealant .....	9-8
Crankcase Splitting.....	9-9
Crankcase Splitting .....	9-9
Crankcase Assembly .....	9-10
Crankshaft and Connecting Rods.....	9-13
Crankshaft Removal .....	9-13
Crankshaft Installation .....	9-13
Connecting Rod Removal.....	9-14
Connecting Rod Installation.....	9-14
Crankshaft/Connecting Rod Cleaning.....	9-18
Connecting Rod Bend.....	9-18
Connecting Rod Twist.....	9-18
Connecting Rod Big End Side Clearance.....	9-18
Connecting Rod Big End Bearing Insert/Crankpin Wear .....	9-19
Crankshaft Side Clearance .....	9-20
Crankshaft Runout.....	9-21
Crankshaft Main Bearing Insert/Journal Wear .....	9-21
Transmission .....	9-23
Shift Pedal Removal .....	9-23
Shift Pedal Installation .....	9-23
External Shift Mechanism Removal.....	9-24
External Shift Mechanism Installation.....	9-24
External Shift Mechanism Inspection.....	9-24
Transmission Shaft Removal .....	9-25
Transmission Shaft Installation .....	9-25
Transmission Shaft Disassembly.....	9-25
Transmission Shaft Assembly.....	9-26
Shift Drum and Fork Removal.....	9-29
Shift Drum and Fork Installation.....	9-29
Shift Drum Disassembly.....	9-29
Shift Drum Assembly .....	9-29
Shift Fork Bending .....	9-29
Shift Fork/Gear Groove Wear .....	9-30
Shift Fork Guide Pin/Drum Groove Wear.....	9-30
Gear Dog and Gear Dog Hole Damage.....	9-30

# 9-2 CRANKSHAFT/TRANSMISSION

## Exploded View

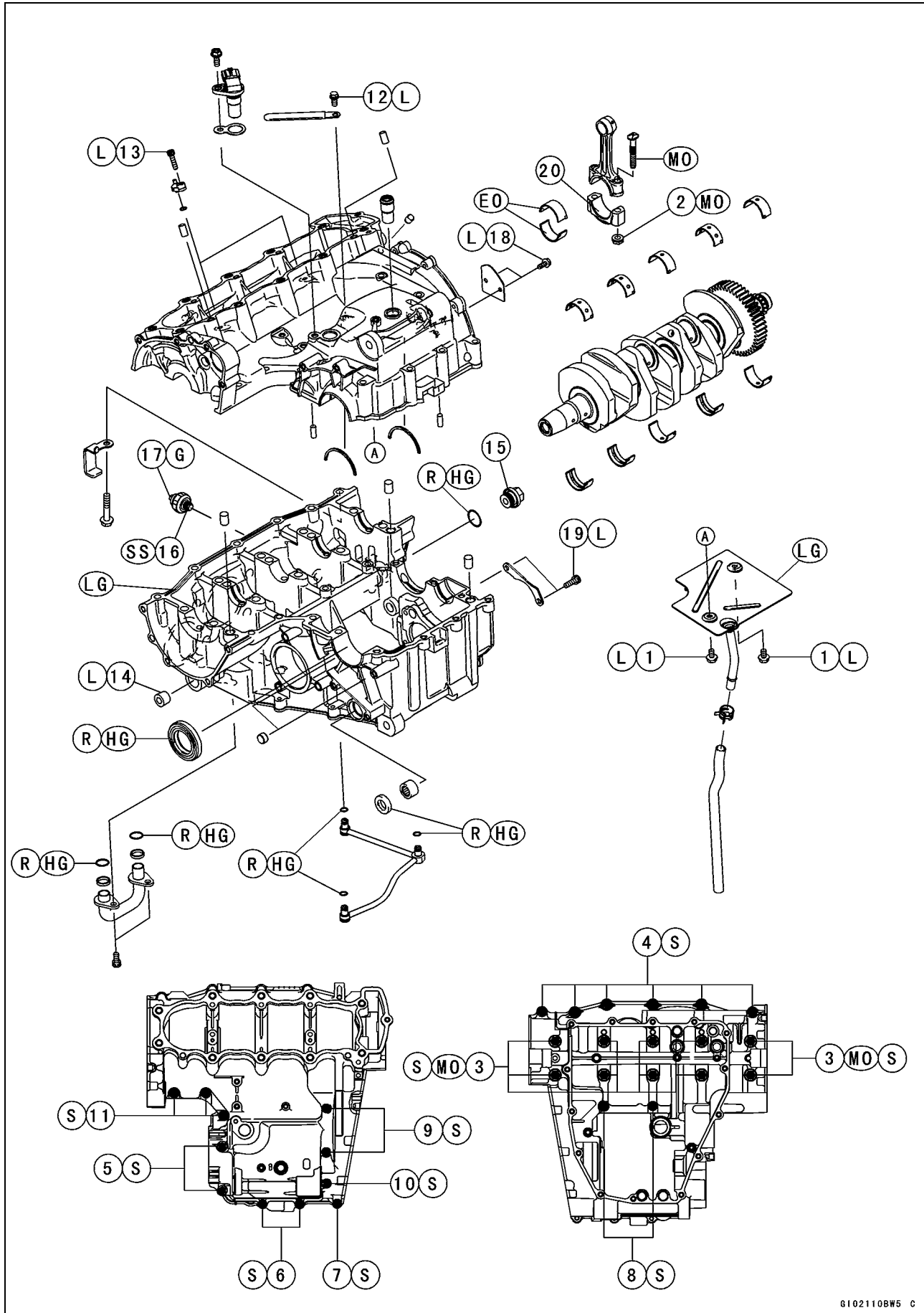

**Exploded View**

No.	Fastener	Torque			Remarks
		N·m	kgf·m	ft·lb	
1	Breather Plate Bolts	5.9	0.60	52 in·lb	L
2	Connecting Rod Big End Nuts	see the text	←	←	←
3	Crankcase Bolts (M8)	31	3.2	23	MO, S
4	Crankcase Bolts (M7, L = 38 mm)	27	2.8	20	S
5	Crankcase Bolt (M7, L = 70 mm)	20	2.0	15	S
6	Crankcase Bolts (M6, L = 65 mm)	12	1.2	104 in·lb	S
7	Crankcase Bolts (M6, L = 50 mm)	12	1.2	104 in·lb	S
8	Crankcase Bolts (M6, L = 38 mm)	12	1.2	104 in·lb	S
9	Crankcase Bolt (M6, L = 95 mm)	12	1.2	104 in·lb	S
10	Crankcase Bolt (M6, L = 85 mm)	12	1.2	104 in·lb	S
11	Crankcase Bolt (M6, L = 35 mm)	12	1.2	104 in·lb	S
12	Harness Clamp Bolt	8.8	0.90	78 in·lb	L
13	Oil Jet Nozzle Bolts	6.9	0.70	61 in·lb	L
14	Oil Passage Plug (Left Side)	20	2.0	15	L
15	Oil Passage Plug (Right Side)	15	1.5	11	
16	Oil Pressure Switch	15	1.5	11	SS
17	Oil Pressure Switch Terminal Bolt	1.5	0.15	13 in·lb	
18	Plate Screws	5.9	0.60	52 in·lb	L
19	Shift Drum Bearing Holder Bolts	12	1.2	104 in·lb	L

20. Do not apply any grease or oil.

EO: Apply engine oil.

G: Apply grease.

HG: Apply high-temperature grease.

L: Apply a non-permanent locking agent.

LG: Apply liquid gasket.

M: Apply molybdenum disulfide grease.

MO: Apply molybdenum disulfide oil solution.

(mixture of the engine oil and molybdenum disulfide grease in a weight ratio 10:1)

R: Replacement Parts

S: Tightening the fasteners following the specified sequence.

SS: Apply silicone sealant.

# 9-4 CRANKSHAFT/TRANSMISSION

## Exploded View

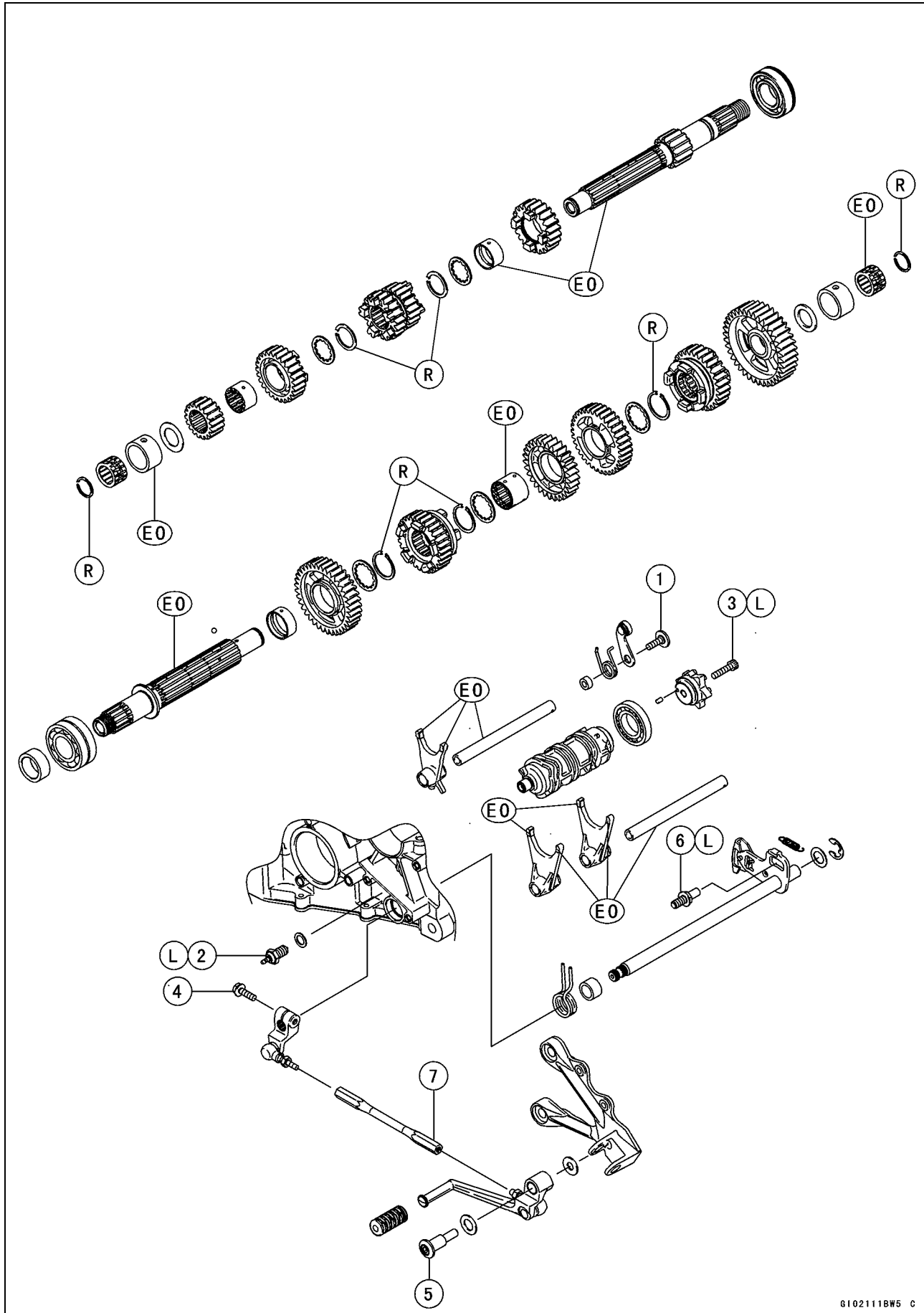

## CRANKSHAFT/TRANSMISSION 9-5

### Exploded View

No.	Fastener	Torque			Remarks
		N·m	kgf·m	ft·lb	
1	Gear Positioning Lever Bolt	12	1.2	104 in·lb	
2	Neutral Switch	15	1.5	11	L
3	Shift Drum Cam Holder Bolt	12	1.2	104 in·lb	L
4	Shift Lever Bolt	6.9	0.70	61 in·lb	
5	Shift Pedal Mounting Bolt	25	2.5	18	
6	Shift Shaft Return Spring Pin	28	2.9	21	L
7	Tie-Rod Locknuts	6.9	0.70	61 in·lb	

EO: Apply engine oil.

L: Apply a non-permanent locking agent.

R: Replacement Parts

## 9-6 CRANKSHAFT/TRANSMISSION

### Specifications

Item	Standard	Service Limit
<b>Crankcase, Crankshaft, Connecting Rods</b>		
Connecting Rod Bend	---	TIR 0.20/100 mm (0.008/3.94 in.)
Connecting Rod Twist	---	TIR 0.20/100 mm (0.008/3.94 in.)
Connecting Rod Big End Side Clearance	0.13 ~ 0.33 mm (0.0051 ~ 0.0130 in.)	0.53 mm (0.021 in.)
Connecting Rod Big End Bearing Insert/Crankpin Clearance	0.031 ~ 0.059 mm (0.0012 ~ 0.0023 in.)	0.10 mm (0.0039 in.)
Crankpin Diameter:	29.984 ~ 30.000 mm (1.1804 ~ 1.1811 in.)	29.97 mm (1.1800 in.)
Marking:		
None	29.984 ~ 29.992 mm (1.1804 ~ 1.1808 in.)	---
○	29.993 ~ 30.000 mm (1.1809 ~ 1.1811 in.)	---
Connecting Rod Big End Inside Diameter:	33.000 ~ 33.016 mm (1.2992 ~ 1.2998 in.)	---
Marking:		
None	33.000 ~ 33.008 mm (1.2992 ~ 1.2995 in.)	---
○	33.009 ~ 33.016 mm (1.2996 ~ 1.2998 in.)	---
Connecting Rod Big End Bearing Insert Thickness:		
Pink	1.475 ~ 1.480 mm (0.05807 ~ 0.05827 in.)	---
Brown	1.480 ~ 1.485 mm (0.05827 ~ 0.05846 in.)	---
Black	1.485 ~ 1.490 mm (0.05846 ~ 0.05866 in.)	---
Connecting Rod Bolt Stretch	(Usable Range) 0.28 ~ 0.38 mm (0.0110 ~ 0.0150 in.)	---
Crankshaft Side Clearance	0.05 ~ 0.15 mm (0.0020 ~ 0.0059 in.)	0.35 mm (0.0138 in.)
Crankshaft Runout	TIR 0.02 mm (0.0008 in.) or less	TIR 0.05 mm (0.0020 in.)
Crankshaft Main Bearing Insert/Journal Clearance	0.010 ~ 0.037 mm (0.0004 ~ 0.0015 in.)	0.07 mm (0.0028 in.)
Crankshaft Main Journal Diameter:	30.984 ~ 31.000 mm (1.2198 ~ 1.2205 in.)	30.96 mm (1.2189 in.)
Marking:		
None	30.984 ~ 30.994 mm (1.2198 ~ 1.2202 in.)	---
1	30.995 ~ 31.000 mm (1.2203 ~ 1.2205 in.)	---

## CRANKSHAFT/TRANSMISSION 9-7

### Specifications

Item	Standard	Service Limit
Crankcase Main Bearing Inside Diameter:	34.000 ~ 34.016 mm (1.3386 ~ 1.3392 in.)	- - -
Marking:		
○	34.000 ~ 34.008 mm (1.3386 ~ 1.3389 in.)	- - -
None	34.009 ~ 34.016 mm (1.3390 ~ 1.3392 in.)	- - -
Crankshaft Main Bearing Insert Thickness:		
Brown	1.491 ~ 1.495 mm (0.0587 ~ 0.0589 in.)	- - -
Black	1.495 ~ 1.499 mm (0.0589 ~ 0.0590 in.)	- - -
Blue	1.499 ~ 1.503 mm (0.0590 ~ 0.0592 in.)	- - -
<b>Transmission</b>		
Shift Fork Ear Thickness	5.9 ~ 6.0 mm (0.232 ~ 0.236 in.)	5.8 mm (0.228 in.)
Gear Groove Width	6.05 ~ 6.15 mm (0.238 ~ 0.242 in.)	6.25 mm (0.246 in.)
Shift Fork Guide Pin Diameter	5.9 ~ 6.0 mm (0.232 ~ 0.236 in.)	5.8 mm (0.228 in.)
Shift Drum Groove Width	6.05 ~ 6.20 mm (0.238 ~ 0.244 in.)	6.3 mm (0.248 in.)

### Connecting Rod Big End Bearing Insert Selection

Con-rod Big End Bore Diameter Marking	Crankpin Diameter Marking	Bearing Insert	
		Size Color	Part Number
None	○	Purple	92139-0089
None	None	Green	92139-0088
○	○		
○	None	Yellow	92139-0087

### Crankshaft Main Bearing Insert Selection

Crankcase Main Bearing Bore Diameter Marking	Crankshaft Main Journal Diameter Marking	Bearing Insert*		
		Size Color	Part Number	Journal Nos.
○	1	Brown	92139-0073	3, 5
			92139-0076	1, 2, 4
None	1	Black	92139-0072	3, 5
○	None		92139-0075	1, 2, 4
None	None	Blue	92139-0071	3, 5
			92139-0074	1, 2, 4

\*: The bearing inserts for Nos. 1, 2 and 4 journals have an oil groove, respectively.

## 9-8 CRANKSHAFT/TRANSMISSION

### Special Tools and Sealant

**Bearing Puller:**

**57001-135**

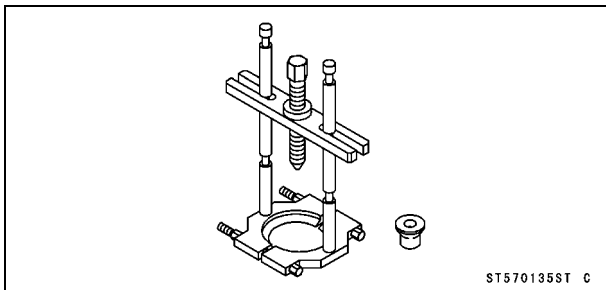

**Bearing Driver,  $\phi$ 32:**

**57001-382**

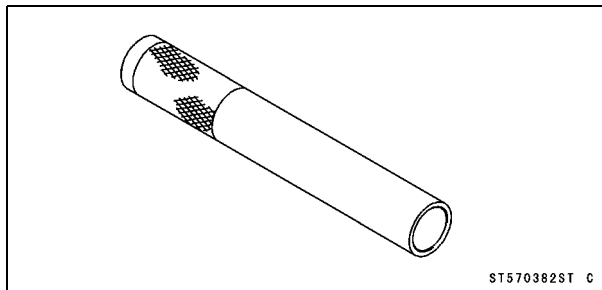

**Outside Circlip Pliers:**

**57001-144**

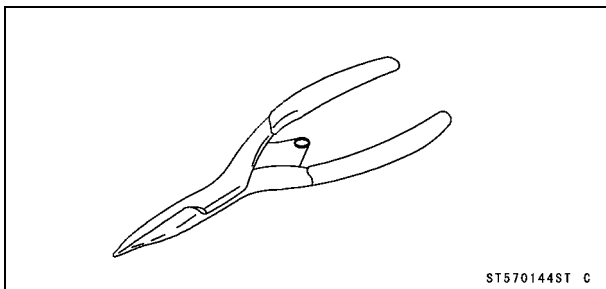

**Kawasaki Bond (Silicone Sealant):**

**56019-120**

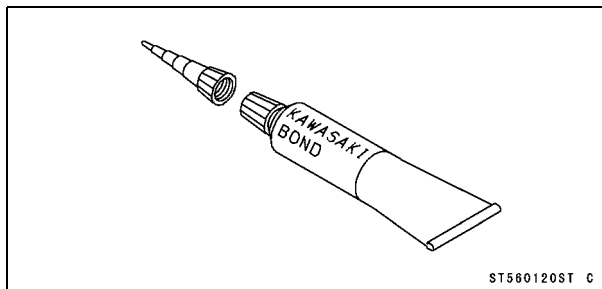

**Bearing Puller Adapter:**

**57001-317**

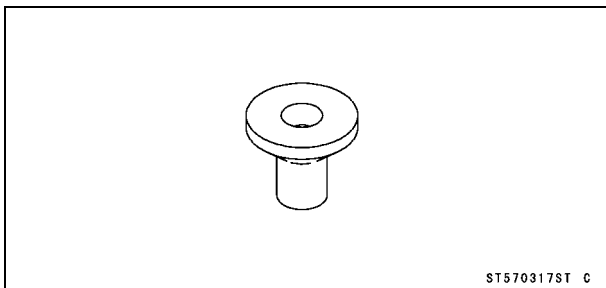

**Kawasaki Bond:**

**92104-1064**

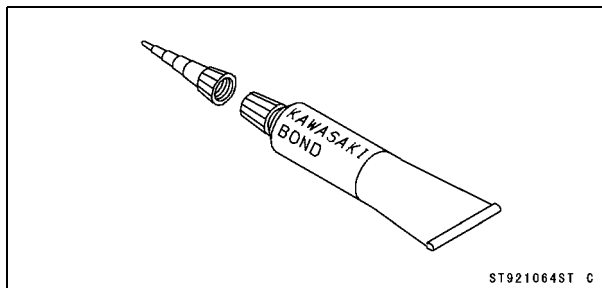

## Crankcase Splitting

### Crankcase Splitting

- Remove the engine (see Engine Removal in the Engine Removal/Installation chapter).
- Set the engine on a clean surface and hold the engine steady while parts are being removed.
- Remove:
  - Crankshaft Sensor (see Crankshaft Sensor Removal in the Electrical System chapter)
  - Clutch (see Clutch Removal in the Clutch chapter)
  - Starter Motor (see Starter Motor Removal in the Electrical System chapter)
  - Oil Pump (see Oil Pump Removal in the Engine Lubrication System chapter)
  - Alternator Rotor (see Alternator Rotor Removal in the Electrical System chapter)
  - Oil Cooler (see Oil Cooler Removal in the Engine Lubrication System chapter)
  - Oil Pan (see Oil Pan Removal in the Engine Lubrication System chapter)
  - Oil Filter (see Oil Filter Replacement in the Periodic Maintenance chapter)
  - External Shift Mechanism (see External Shift Mechanism Removal in this chapter)
- ★ If the crankshaft is to be removed, remove the pistons (see Piston Removal in the Engine Top End chapter).

- Remove the upper crankcase bolts.
  - First loosen the M6 bolts.
    - M6 Bolts [A]
    - M7 Bolts [B]

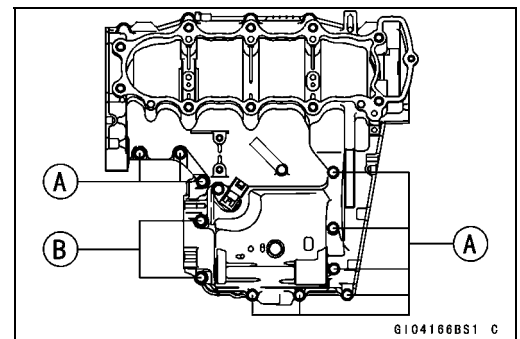

- Remove the lower crankcase bolts.
  - First loosen the M6 bolts.
    - M6 Bolts [A]
    - M7 Bolts [B]
    - M8 Bolts [C]
- Tap lightly around the crankcase mating surface with a plastic mallet, and split the crankcase. Take care not to damage the crankcase.

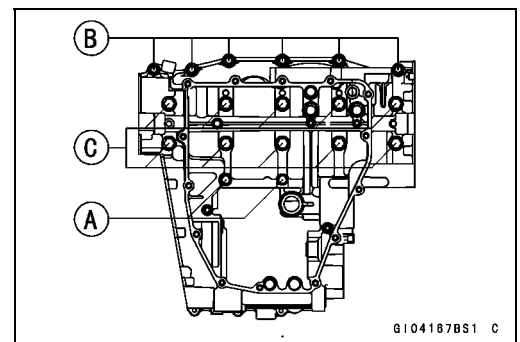

# 9-10 CRANKSHAFT/TRANSMISSION

## Crankcase Splitting

### Crankcase Assembly

#### CAUTION

The upper and lower crankcase halves are machined at the factory in the assembled state, so the crankcase halves must be replaced as a set.

- With a high-flash point solvent, clean off the mating surfaces of the crankcase halves and wipe dry.
- Using compressed air, blow out the oil passages in the crankcase halves.
- Apply liquid gasket to the breather plate mating surface [A] 1 ~ 1.5 mm (0.04 ~ 0.06 in.) thick, and then install the breather plate.

Sealant - Three Bond: **TB1207B**

- Apply a non-permanent locking agent to the threads and tighten the bolts [A].

Torque - Breather Plate Bolts: **5.9 N·m (0.60 kgf·m, 52 in·lb)**

- Apply grease to the O-ring.
- Install the oil jet nozzles [A].
- Apply a non-permanent locking agent to the threads of oil jet nozzle bolts.
- Tighten:

Torque - Oil Jet Nozzle Bolts: **6.9 N·m (0.70 kgf·m, 61 in·lb)**

- Install:
  - Crankshaft and Connecting Rods
  - Camshaft Chain [A]
  - Transmission Shafts and Gears
  - Dowel Pins [B]
  - Shift Drum
  - Shift Forks and Shift Rods
- Before fitting the lower case on the upper case, check the following.
  - Be sure to hang the camshaft chain on the crankshaft.
  - Check to see that the shift drum and transmission gears are in the neutral position.

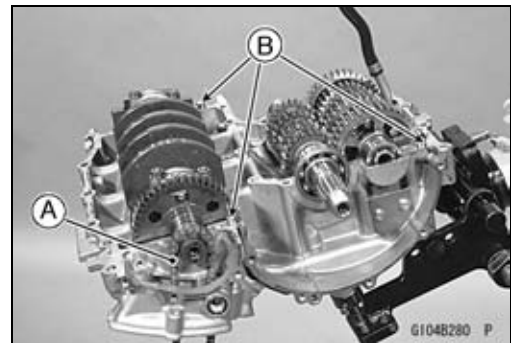
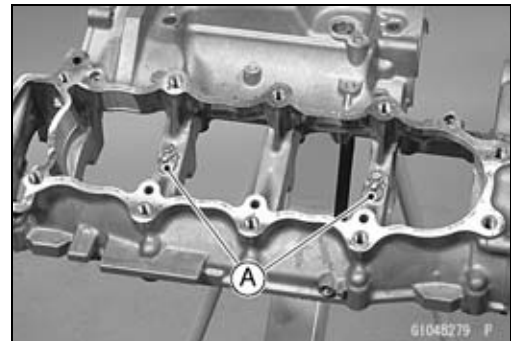
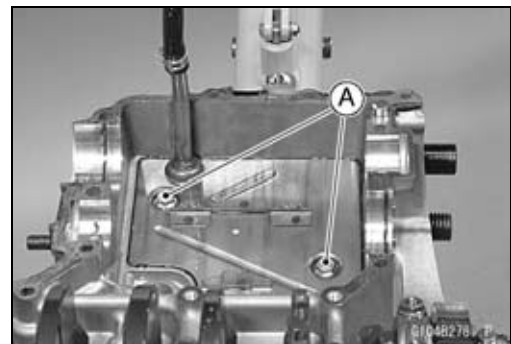
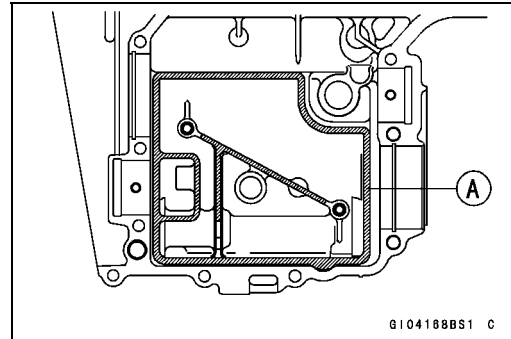

## Crankcase Splitting

- Apply liquid gasket to the mating surface of the lower crankcase half.

Sealant - Kawasaki Bond: 92104-1064

### NOTE

- Especially, apply a sealant carefully so that it shall be filled up on the grooves.

### CAUTION

Do not apply liquid gasket around the crankshaft main bearing inserts, and oil passage holes.

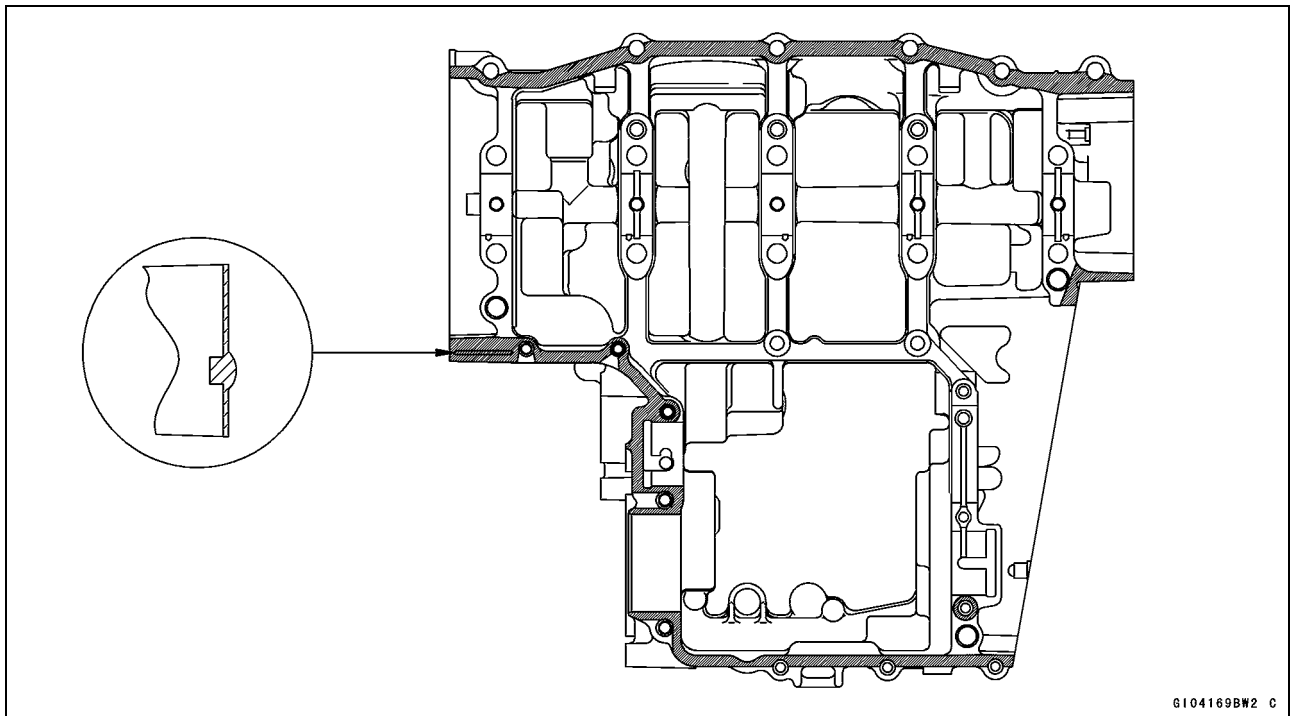

- Fit the lower crankcase to the upper crankcase.

## 9-12 CRANKSHAFT/TRANSMISSION

### Crankcase Splitting

- The M8 bolts has a copper plated washer, replace it with a new one.
- Apply molybdenum disulfide oil to both side [C] of the copper plated washers and threads [B] of M8 bolts [A].

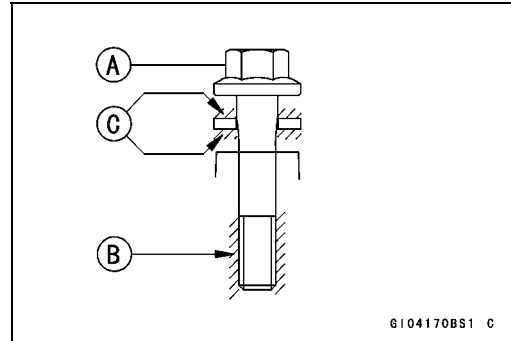

- Tighten the lower crankcase bolts using the following steps.
  - Following the sequence numbers on the lower crankcase half, tighten the M8 bolts [1 ~ 10] with copper plated washers.
    - L = 71 mm (2.80 in.) [1 ~ 6]
    - L = 94 mm (3.70 in.) [7 ~ 10]
- Torque - Crankcase Bolts (M8) [A]: 31 N·m (3.2 kgf·m, 23 ft·lb)**

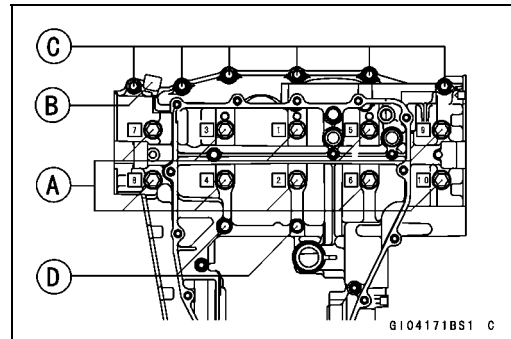

- Install the clamp [B] as shown.
  - Tighten the M7 bolts [C].
- Torque - Crankcase Bolts (M7): 27 N·m (2.8 kgf·m, 20 ft·lb)**
  - Tighten the M6 bolts [D].

**Torque - Crankcase Bolts (M6): 12 N·m (1.2 kgf·m, 104 in·lb)**

- Tighten the upper crankcase bolts using the following steps.
  - The M6 (L = 95 mm (3.74 in.)) bolts has a copper plated washer, replace it with a new one.
  - Tighten the M7 bolts.
- Torque - Crankcase Bolts (M7) [A]: 20 N·m (2.0 kgf·m, 15 ft·lb)**
- Crankcase Bolts (M6): 12 N·m (1.2 kgf·m, 104 in·lb)**

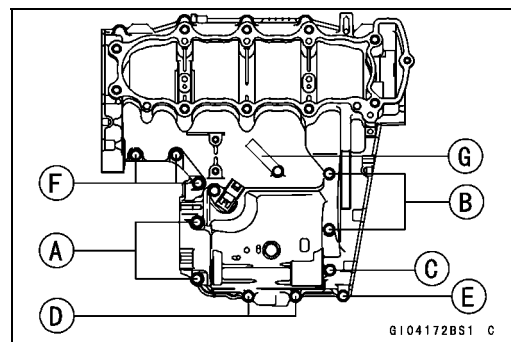

- L = 95 mm (3.74 in.) [B]  
(with Copper Plated Washers)
- L = 85 mm (3.35 in.) [C]
- L = 65 mm (2.56 in.) [D]
- L = 50 mm (1.97 in.) [E]
- L = 35 mm (1.38 in.) [F]

- Install the clamp [G] as shown.
- Apply a non-permanent locking agent to the clamp bolt, and tighten it.

**Torque - Harness Clamp Bolt: 8.8 N·m (0.90 kgf·m, 78 in·lb)**

- After tightening all crankcase bolts, check the following items.
- Crankshaft and transmission shafts turn freely.
- While spinning the output shaft, gears shift smoothly from the 1st to 6th gear, and 6th to 1st.
- When the output shaft stays still, the gear can not be shifted to 2nd gear or other higher gear positions.

**Crankshaft and Connecting Rods**

*Crankshaft Removal*

- See Connecting Rod Removal in this chapter.

*Crankshaft Installation*

- If the crankshaft is replaced with a new one, select the proper crankshaft in accordance with the combination of the crankshaft and clutch housing gear markings.

Clutch Housing Gear [A]

Crankshaft [B]

**NOTE**

○ Be sure to confirm the marking on the crankshaft.

**Crankshaft Selection when Replacing Crankshaft**

Clutch Housing Gear Marking [D]	Crankshaft	
	Marking [C]	Part Number
A	A	13031-0041
None	None	13031-0042
B	B	13031-0043
C	C	13031-0044

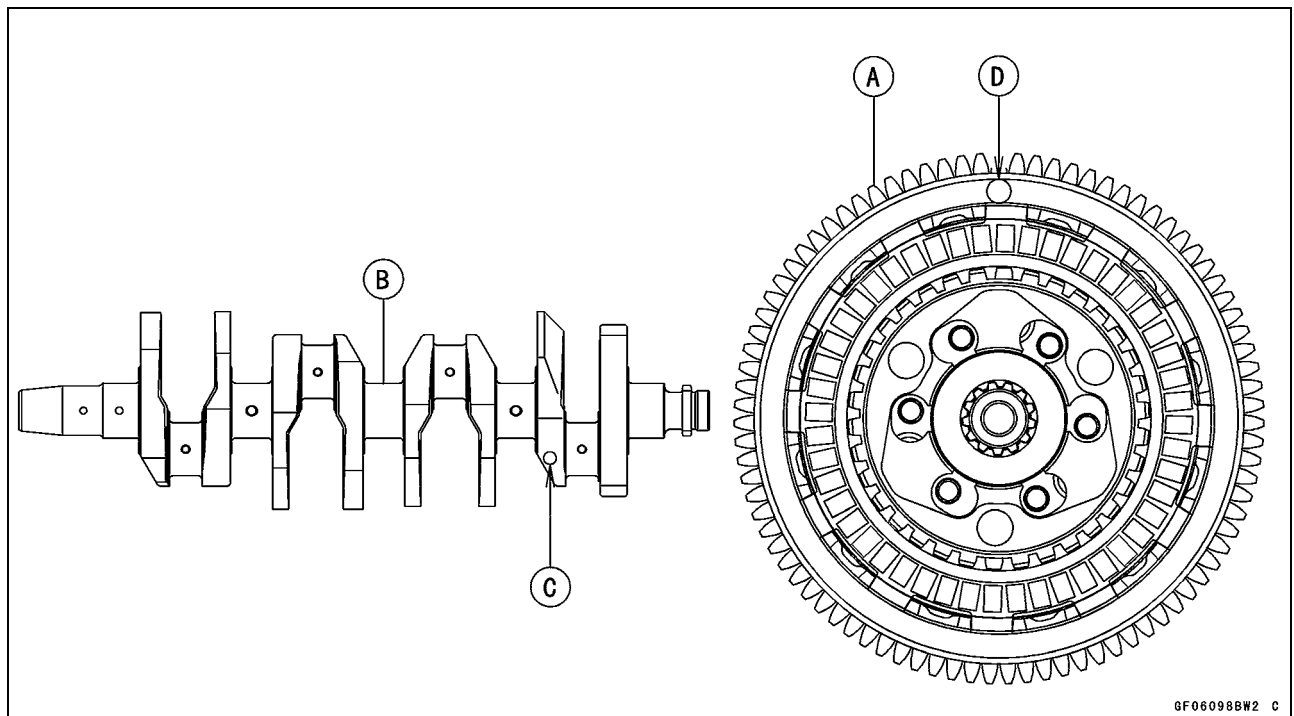

## 9-14 CRANKSHAFT/TRANSMISSION

### Crankshaft and Connecting Rods

#### NOTE

○If the crankshaft is replaced with a new one, refer to the *Connecting Rod Big End Bearing/Crankshaft Main Bearing Insert Selection in the Specifications*.

#### CAUTION

If the crankshaft, bearing inserts, or crankcase halves are replaced with new ones, select the bearing inserts and check clearance with a plastigage (press gauge) before assembling engine to be sure the correct bearing inserts are installed.

- Apply molybdenum disulfide oil solution to the crankshaft main bearing inserts.
- Install the crankshaft with the camshaft chain [A] hanging on it.

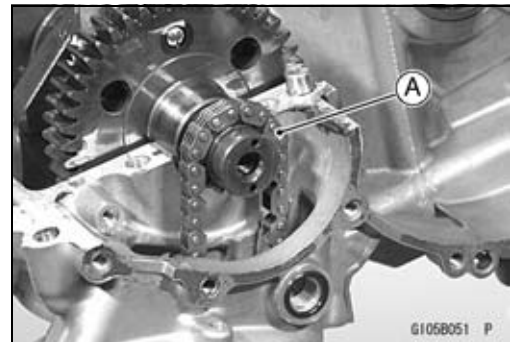

#### Connecting Rod Removal

- Split the crankcase (see *Crankcase Splitting* in this chapter).
- Remove the connecting rod nuts [A].
- Remove the crankshaft.

#### NOTE

○Mark and record the locations of the connecting rods and their big end caps so that they can be reassembled in their original positions.

- Remove the connecting rod from the crankshaft.

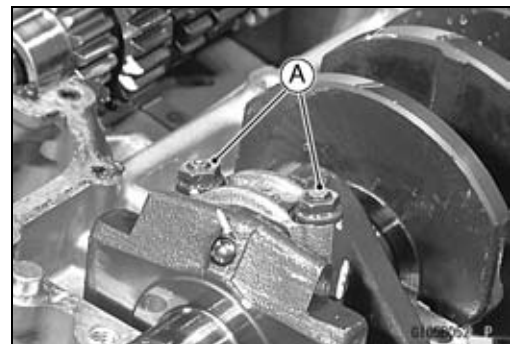

#### CAUTION

Discard the connecting rod bolts. To prevent damage to the crankpin surfaces, do not allow the connecting rod bolts to bump against the crankpins.

#### Connecting Rod Installation

#### CAUTION

To minimize vibration, the connecting rods should have the same weight mark.

- Big End Cap [A]
- Connecting Rod [B]
- Weight Mark, Alphabet [C]
- Diameter Mark [D]: "○" mark or no mark

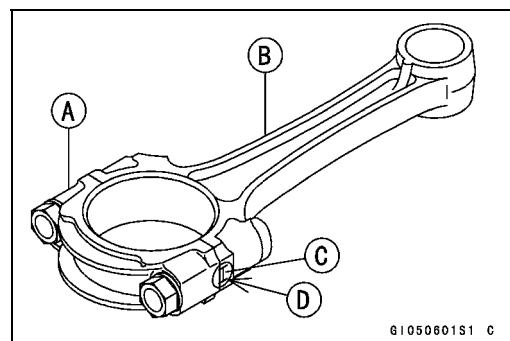

#### CAUTION

If the connecting rods, big end bearing inserts, or crankshaft are replaced with new ones, select the bearing insert and check clearance with a plastigage (press gauge) before assembling engine to be sure the correct bearing inserts are installed.

**Crankshaft and Connecting Rods**

- Apply molybdenum disulfide oil to the inner surface of the upper and lower bearing inserts [A].
- Apply molybdenum disulfide oil to the threads [B] and seating surface [C] of the connecting rod nuts.
- Install the inserts so that their nails [D] are on the same side and fit them into the recess of the connecting rod and cap.

<b>CAUTION</b>
<b>Wrong application of oil and grease could cause bearing damage.</b>

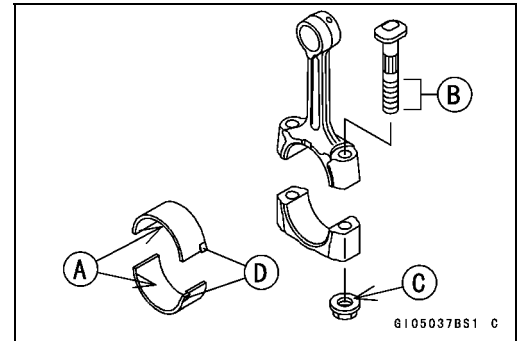

- When installing the inserts [A], be careful not to damage the insert surface with the edge of the connecting rod [B] or the cap [C]. One way to install inserts is as follows.

- Installation [D] to Cap
- Installation [E] to Connecting Rod
- Push [F]
- Spare Dowel Pin [G]
- Connecting Rod Bolts [H]

- Remove debris and clean the surface of inserts.
- Install the cap on the connecting rod, aligning the weight and diameter marks.

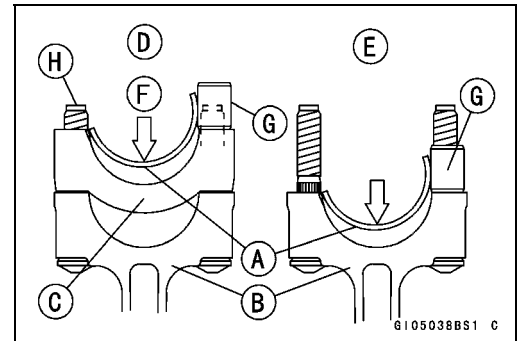

- Install the crankshaft (see Crankshaft Installation in this chapter).
- Install each connecting rod on its original crankpin.
- The connecting rod big end is bolted using the “plastic region fastening method”.
- This method precisely achieves the needed clamping force without exceeding it unnecessarily, allowing the use of thinner, lighter bolts further decreasing connecting rod weight.
- There are two types of the plastic region fastening. One is a bolt length measurement method and other is a rotation angle method. Observe one of the following two, but the bolt length measurement method is preferable because this is a more reliable way to tighten the big end nuts.

<b>CAUTION</b>
<b>The connecting rod bolts are designed to stretch when tightened. Never reuse the connecting rod bolts. See the table below for correct bolt and nut usage.</b>

<b>CAUTION</b>
<b>Be careful not to overtighten the nuts. The bolts must be positioned on the seating surface correctly to prevent the bolt heads from hitting the crankcase.</b>

## 9-16 CRANKSHAFT/TRANSMISSION

### Crankshaft and Connecting Rods

#### (1) Bolt Length Measurement Method

- Be sure to clean the bolts, nuts, and connecting rods thoroughly with a high-flash point solvent, because the new connecting rods, bolts, and nuts are treated with an anti-rust solution.

#### **⚠ WARNING**

**Clean the bolts, nuts, and connecting rods in a well-ventilated area, and take care that there is no spark or flame anywhere near the working area. This includes any appliance with a pilot light. Because of the danger of highly flammable liquids, do not use gasoline or low-flash point solvents to clean them.**

#### **CAUTION**

**Immediately dry the bolts and nuts with compressed air after cleaning. Clean and dry the bolts and nuts completely.**

- Install new bolts in reused connecting rods.
- Dent both bolt head and bolt tip with a punch as shown.
- Before tightening, use a point micrometer to measure the length of new connecting rod bolts and record the values to find the bolt stretch.  
Connecting Rod [A]  
Dent here with a punch [B].  
Nuts [C]  
Fit micrometer pins into dents [D].
- Apply a small amount of molybdenum disulfide oil to the following.  
Threads of Nuts and Bolts  
Seating Surfaces of Nuts and Connecting rods
- Tighten the big end nuts until the bolt elongation reaches the length specified in the table.
- Check the length of the connecting rod bolts.
- ★ If the stretch is more than the usable range, the bolt has stretched too much. An overelongated bolt may break in use.

$$\text{Bolt Length after tightening} - \text{Bolt Length before tightening} = \text{Bolt Stretch}$$

**Usable Range of Connecting Rod Bolt Stretch**  
**0.28 ~ 0.38 mm (0.0110 ~ 0.0150 in.)**

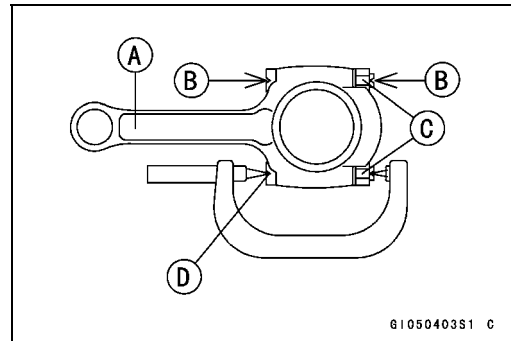

**Crankshaft and Connecting Rods**

(2) Rotation Angle Method

- ★ If you don't have a point micrometer, you may tighten the nuts using the "Rotation Angle Method".
- Be sure to clean the bolts, nuts and connecting rods thoroughly with a high-flash point solvent, because the new connecting rods, bolts and nuts are treated with an anti-rust solution.

**⚠ WARNING**

**Clean the bolts, nuts and connecting rods in a well-ventilated area, and take care that there is no spark or flame anywhere near the working area. This includes any appliance with a pilot light. Because of the danger of highly flammable liquids, do not use gasoline or low-flash point solvents to clean them.**

**CAUTION**

**Immediately dry the bolts and nuts with compressed air after cleaning. Clean and dry the bolts and nuts completely.**

- Install new bolts in reused connecting rods.
- Apply a small amount of molybdenum disulfide oil to the following.
  - Threads [A] of Nuts and Bolts
  - Seating Surfaces [B] of Nuts and Connecting Rods

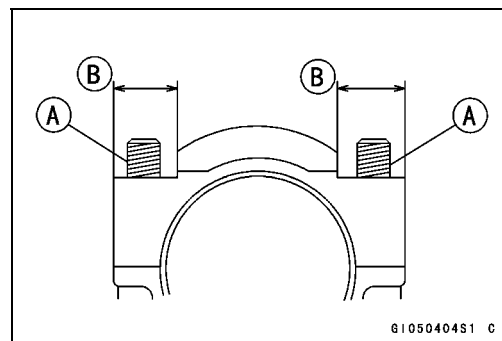

- First, tighten the nuts to the specified torque (see table below).
- Next, tighten the nuts **150°**.
- Mark [A] the connecting rod big end caps and nuts so that nuts can be turned 150° [B] properly.
- Mark [A] the connecting rod big end caps and nuts so that nuts can be turned 180° [C] properly.

Connecting Rod Assy	Bolt, Nut	Torque + Angle N·m (kgf·m, in·lb)
New	Use the bolts attached to new con-rod.	13 (1.3, 113) + 150°
	Another new bolts and nuts	13 (1.3, 113) + 180°
Used	Replace the bolts and nuts with new ones	13 (1.3, 113) + 180°

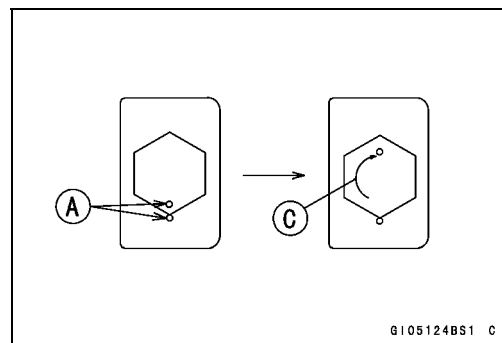
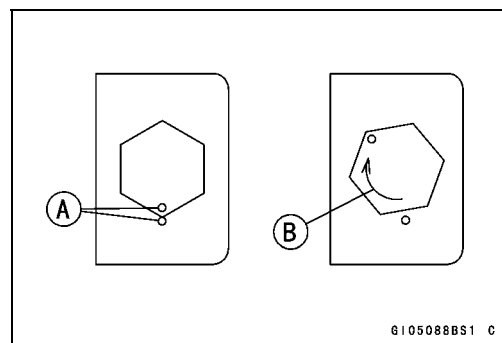

**CAUTION**

**Be careful not to overtighten the nuts.**

## 9-18 CRANKSHAFT/TRANSMISSION

### Crankshaft and Connecting Rods

#### Crankshaft/Connecting Rod Cleaning

- After removing the connecting rods from the crankshaft, clean them with a high-flash point solvent.
- Blow the crankshaft oil passages with compressed air to remove any foreign particles or residue that may have accumulated in the passages.

#### Connecting Rod Bend

- Remove the connecting rod big end bearing inserts, and reinstall the connecting rod big end cap.
- Select an arbor [A] of the same diameter as the connecting rod big end, and insert the arbor through the connecting rod big end.
- Select an arbor of the same diameter as the piston pin and at least 105 mm (4.13 in.) long, and insert the arbor [B] through the connecting rod small end.
- On a surface plate, set the big-end arbor on V block [C].
- With the connecting rod held vertically, use a height gauge to measure the difference in the height of the arbor above the surface plate over a 100 mm (3.94 in.) length to determine the amount of connecting rod bend.
- ★ If connecting rod bend exceeds the service limit, the connecting rod must be replaced.

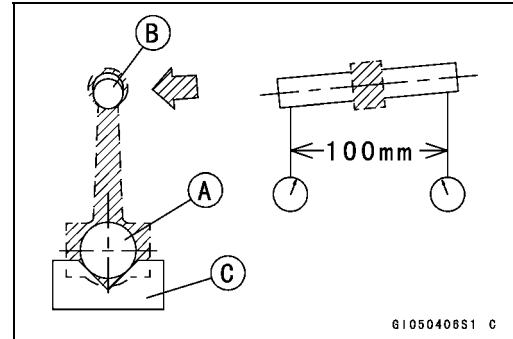

#### Connecting Rod Bend

**Service Limit: TIR 0.2/100 mm (0.008/3.94 in.)**

#### Connecting Rod Twist

- With the big-end arbor [A] still on V block [C], hold the connecting rod horizontally and measure the amount that the arbor [B] varies from being paralleled with the surface plate over a 100 mm (3.94 in.) length of the arbor to determine the amount of connecting rod twist.
- ★ If connecting rod twist exceeds the service limit, the connecting rod must be replaced.

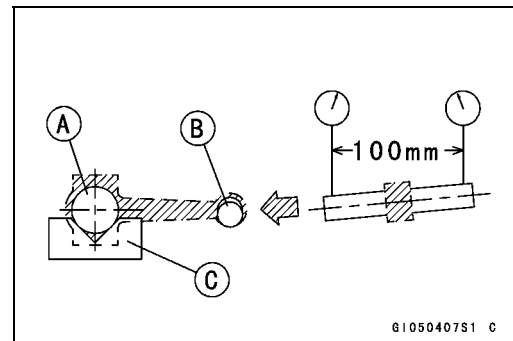

#### Connecting Rod Twist

**Service Limit: TIR 0.2/100 mm (0.008/3.94 in.)**

#### Connecting Rod Big End Side Clearance

- Measure connecting rod big end side clearance.
- Insert a thickness gauge [A] between the big end and either crank web to determine clearance.

#### Connecting Rod Big End Side Clearance

**Standard: 0.13 ~ 0.33 mm (0.0051 ~ 0.0130 in.)**

**Service Limit: 0.53 mm (0.021 in.)**

- ★ If the clearance exceeds the service limit, replace the connecting rod with new one and then check clearance again. If clearance is too large after connecting rod replacement, the crankshaft also must be replaced.



**Crankshaft and Connecting Rods**

*Connecting Rod Big End Bearing Insert/Crankpin Wear*

- Measure the bearing insert/crankpin [B] clearance with plastigage [A].
- Tighten the big end nuts to the specified torque (see Connecting Rod Installation in this chapter).

**NOTE**

○ Do not move the connecting rod and crankshaft during clearance measurement.

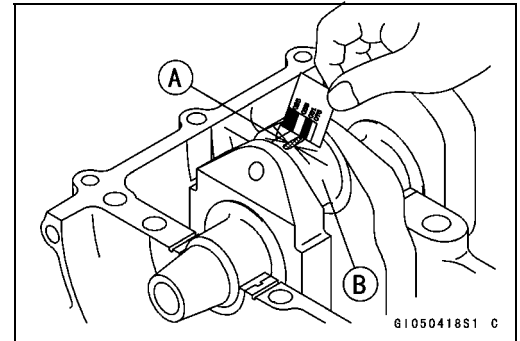

**CAUTION**

**After measurement, replace the connecting rod bolts.**

**Connecting Rod Big End Bearing Insert/Crankpin Clearance**  
**Standard: 0.031 ~ 0.059 mm (0.0012 ~ 0.0023 in.)**  
**Service Limit: 0.10 mm (0.0039 in.)**

- ★ If the clearance is within the standard, no bearing replacement is required.
- ★ If the clearance is between 0.060 mm (0.002 in.) and the service limit (0.10 mm, 0.004 in.), replace the bearing inserts [A] with inserts painted yellow [B]. Check insert/crankpin clearance with the plastigage. The clearance may exceed the standard slightly, but it must not be less than the minimum in order to avoid bearing seizure.
- ★ If the clearance exceeds the service limit, measure the diameter [C] of the crankpins.

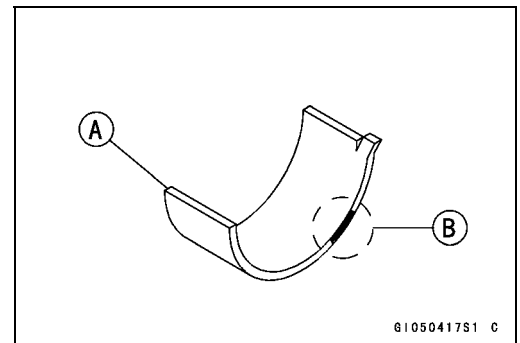

**Crankpin Diameter**

**Standard: 29.984 ~ 30.000 mm (1.1804 ~ 1.1811 in.)**  
**Service Limit: 29.97 mm (1.1800 in.)**

- ★ If any crankpin has worn past the service limit, replace the crankshaft with a new one.
- ★ If the measured crankpin diameters are not less than the service limit, but do not coincide with the original diameter markings [D] on the crankshaft, make new marks on it.

**Crankpin Diameter Marks**

**None: 29.984 ~ 29.992 mm (1.1804 ~ 1.1808 in.)**

○: **29.993 ~ 30.000 mm (1.1809 ~ 1.1811 in.)**

△: Crankpin Diameter Marks, “○” mark or no mark.

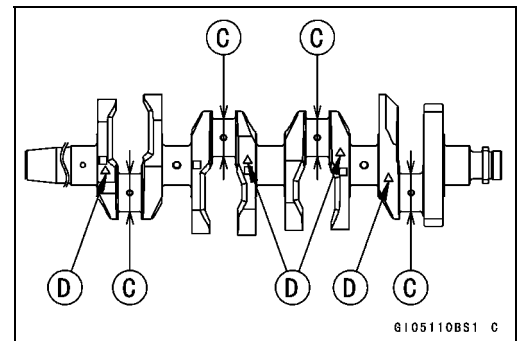

- Measure the connecting rod big end inside diameter, and mark each connecting rod big end in accordance with the inside diameter.
- Tighten the connecting rod big end nuts to the specified torque (see Connecting Rod Installation in this chapter).

**NOTE**

○ The mark already on the big end should almost coincide with the measurement.

# 9-20 CRANKSHAFT/TRANSMISSION

## Crankshaft and Connecting Rods

### Connecting Rod Big End Inside Diameter Marks

None: 33.000 ~ 33.008 mm (1.2992 ~ 1.2995 in.)

○: 33.009 ~ 33.016 mm (1.2996 ~ 1.2998 in.)

Big End Cap [A]

Connecting Rod [B]

Weight Mark, Alphabet [C]

Diameter Mark (Around Weight Mark) [D]: "○" mark or no mark

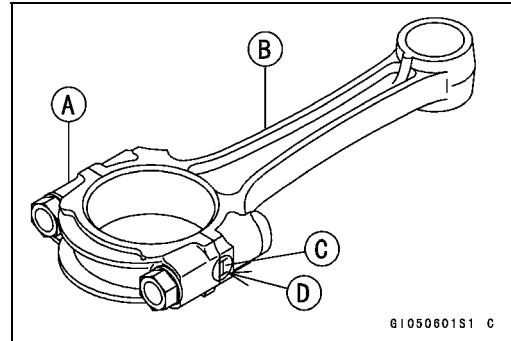

- Select the proper bearing insert [A] in accordance with the combination of the connecting rod and crankshaft coding.  
Size Color [B]

Con-rod Big End Inside Diameter Marking	Crankpin Diameter Marking	Bearing Insert	
		Size Color	Part Number
None	○	Purple	92139-0089
None	None	Green	92139-0088
○	○		
○	None	Yellow	92139-0087

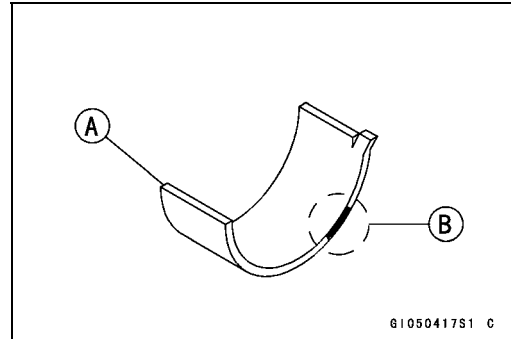

- Install the new inserts in the connecting rod and check insert/crankpin clearance with the plastigage.
- ★ If the insert/crankpin clearance is less than the service limit, replace the connecting rod bolts and nuts with new ones and measure the clearance again.

### Crankshaft Side Clearance

- Insert a thickness gauge [A] between the crankcase main bearing and the crank web at the No.2 journal [B] to determine clearance.
- ★ If the clearance exceeds the service limit, replace the crankcase halves as a set.

### NOTE

○ The upper and lower crankcase halves are machined at the factory in the assembled state, so the crankcase halves must be replaced as a set.

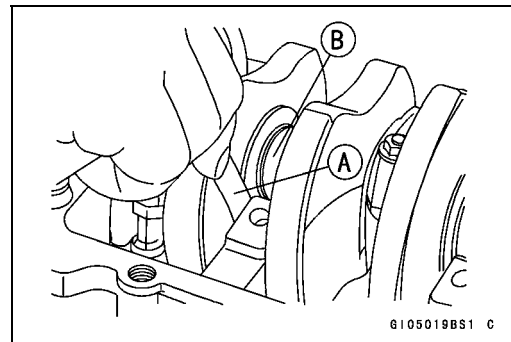

### Crankshaft Side Clearance

Standard: 0.05 ~ 0.15 mm (0.0020 ~ 0.0059 in.)

Service Limit: 0.35 mm (0.0138 in.)

**Crankshaft and Connecting Rods**

**Crankshaft Runout**

- Measure the crankshaft runout.
- ★ If the measurement exceeds the service limit, replace the crankshaft.

**Crankshaft Runout**

- Standard:** TIR 0.02 mm (0.0008 in.) or less
- Service Limit:** TIR 0.05 mm (0.0020 in.)

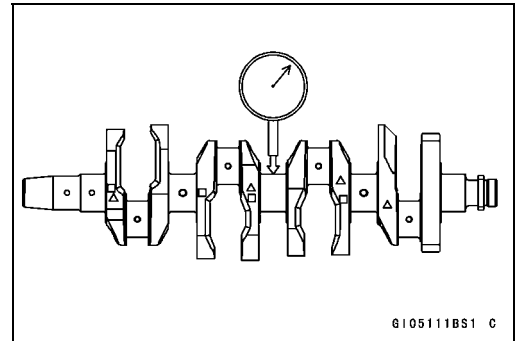

**Crankshaft Main Bearing Insert/Journal Wear**

- Using a plastigage (press gauge) [A], measure the bearing insert/journal [B] clearance.

**NOTE**

- Tighten the crankcase bolts to the specified torque (see Crankcase Assembly in this chapter).
- Do not turn the crankshaft during clearance measurement.
- Journal clearance less than 0.025 mm (0.00098 in.) can not be measured by plastigage, however, using genuine parts maintains the minimum standard clearance.

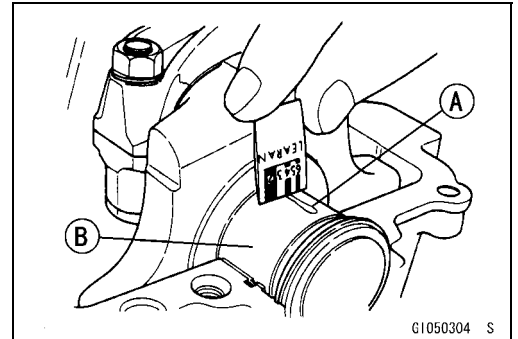

**Crankshaft Main Bearing Insert/Journal Clearance**

- Standard:** 0.010 ~ 0.037 mm (0.0004 ~ 0.0015 in.)
- Service Limit:** 0.07 mm (0.0028 in.)

- ★ If the clearance is within the standard, no bearing replacement is required.
- ★ If the clearance is between 0.038 mm (0.0015 in.) and the service limit (0.07 mm, 0.0028 in.), replace the bearing inserts [A] with inserts painted blue [B]. Check insert/journal clearance with the plastigage. The clearance may exceed the standard slightly, but it must not be less than the minimum in order to avoid bearing seizure.
- ★ If the clearance exceeds the service limit, measure the diameter [C] of the crankshaft main journal.

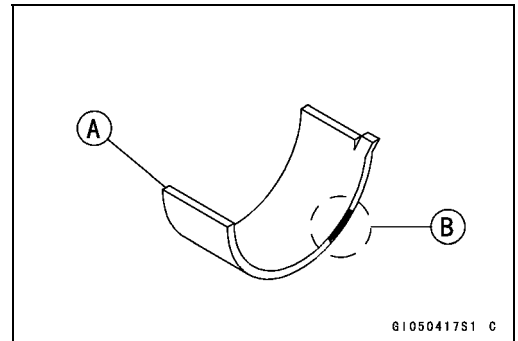

**Crankshaft Main Journal Diameter**

- Standard:** 30.984 ~ 31.000 mm (1.2198 ~ 1.2202 in.)
- Service Limit:** 30.96 mm (1.2189 in.)

- ★ If any journal has worn past the service limit, replace the crankshaft with a new one.
- ★ If the measured journal diameters are not less than the service limit, but do not coincide with the original diameter markings [D] on the crankshaft, make new marks on it.

**Crankshaft Main Journal Diameter Marks**

- None:** 30.984 ~ 30.992 mm (1.2198 ~ 1.2202 in.)
- 1:** 30.993 ~ 31.000 mm (1.2203 ~ 1.2205 in.)

□: Crankshaft Main Journal Diameter Marks, "1" mark or no mark.

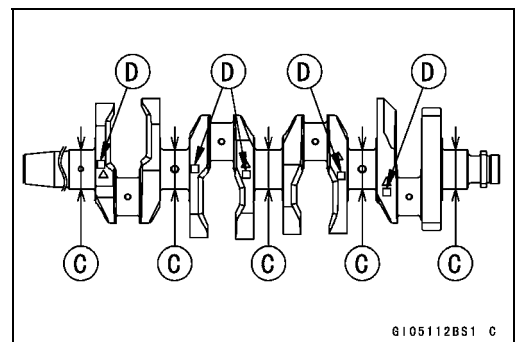

## 9-22 CRANKSHAFT/TRANSMISSION

### Crankshaft and Connecting Rods

- Measure the main bearing inside diameter, and mark the upper crankcase half in accordance with the inside diameter.

[A]: Crankcase Main Bearing Inside Diameter Marks, “○” mark or no mark.

- Tighten the crankcase bolts to the specified torque (see Crankcase Assembly in this chapter).

#### NOTE

○ The mark already on the upper crankcase half should almost coincide with the measurement.

#### Crankcase Main Bearing Inside Diameter Marks

○: 34.000 ~ 34.008 mm (1.3386 ~ 1.3389 in.)

None: 34.009 ~ 34.016 mm (1.3390 ~ 1.3392 in.)

- Select the proper bearing insert [A] in accordance with the combination of the crankcase and crankshaft coding.  
Size Color [B]

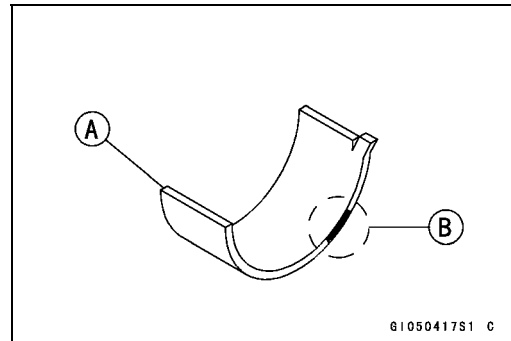
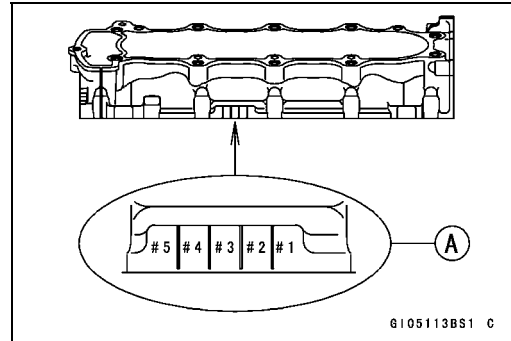

Crankcase Main Bearing Inside Diameter Marking	Crankshaft Main Journal Diameter Marking	Bearing Insert*		
		Size Color	Part Number	Journal Nos.
○	1	Brown	92139-0073	3, 5
			92139-0076	1, 2, 4
None	1	Black	92139-0072	3, 5
○	None		92139-0075	1, 2, 4
None	None	Blue	92139-0071	3, 5
			92139-0074	1, 2, 4

\*: The bearing inserts for Nos. 1, 2 and 4 journals have an oil groove, respectively.

- Install the new inserts in the crankcase halves and check insert/journal clearance with the plastigage.

**Transmission**

*Shift Pedal Removal*

- Mark [A] the position of the shift lever [B] on the shift shaft so that it can be installed later in the same position.
- Remove:
  - Shift Lever Bolt [C]
  - Shift Lever

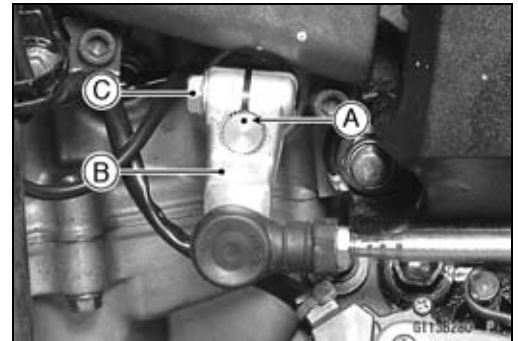

- Remove:
  - Shift Pedal Mounting Bolt [A]
  - Tie-Rod [B]

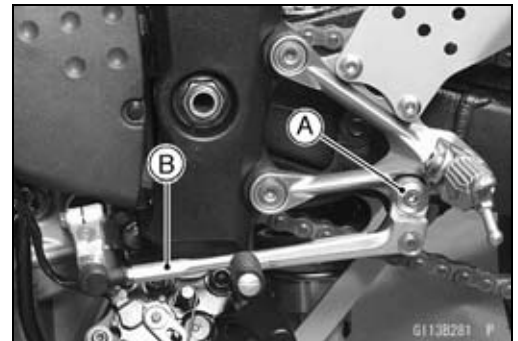

*Shift Pedal Installation*

- Apply grease to the sliding surfaces [A] on the shift pedal mounting bolt.
- Tighten:
  - Torque - Shift Pedal Mounting Bolt [B]: 25 N·m (2.5 kgf·m, 18 ft·lb)**
  - Footpeg Bracket [C]
  - Shift Pedal [D]
  - Washer [E]

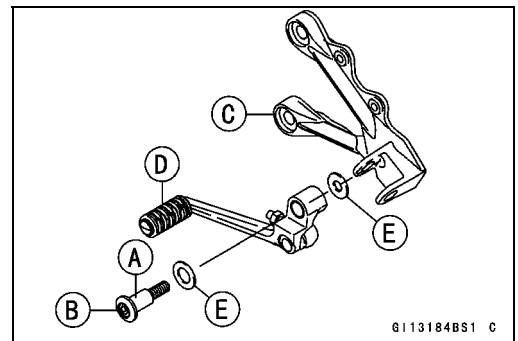

- Install the shift lever [A], aligning the mark (previously marked).
- Tighten:
  - Torque - Shift Lever Bolt: 6.9 N·m (0.70 kgf·m, 61 in·lb)**
- Install the shift pedal [B] as shown.
  - About 90° [C]
  - 5 ~ 7 mm (0.20 ~ 0.28 in.) [D]
- To adjust the pedal position, loosen the front locknut [E] (left-hand threads) and rear locknut [F] and then turn the tie-rod [G].
- Tighten:
  - Torque - Tie-Rod Locknuts: 6.9 N·m (0.70 kgf·m, 61 in·lb)**

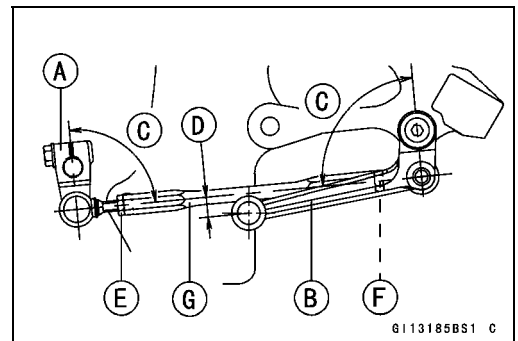

## 9-24 CRANKSHAFT/TRANSMISSION

### Transmission

#### External Shift Mechanism Removal

- Remove:
  - Engine Oil (see Drain, Engine Oil Change in the Periodic Maintenance chapter)
  - Clutch (see Clutch Removal in the Clutch chapter)
  - Shift Pedal (see Shift Pedal Removal in this chapter)
- Remove the shift shaft assembly [A] while pulling the shift mechanism arm.
  
- Remove:
  - Gear Positioning Lever Bolt [A]
  - Gear Positioning Lever [B]
  - Collar and Spring

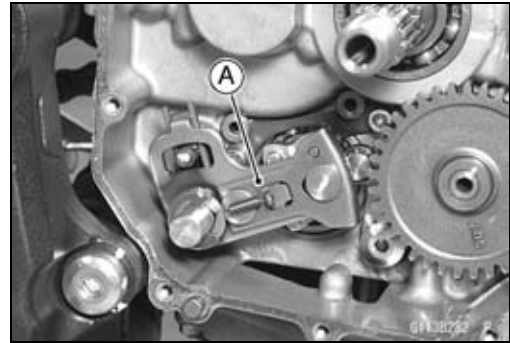

#### External Shift Mechanism Installation

- Install the gear positioning lever [A] as shown.
  - Spring [B]
  - Collar [C]
  - Bolt [D]
- Tighten:
  - Torque - Gear Positioning Lever Bolt: 12 N·m (1.2 kgf·m, 104 in·lb)**

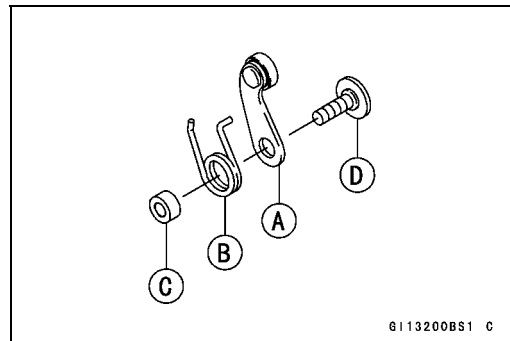

#### External Shift Mechanism Inspection

- Examine the shift shaft [A] for any damage.
  - ★ If the shaft is bent, replace it.
  - ★ If the serration [B] are damaged, replace the shaft.
  - ★ If the springs [C] are damaged in any way, replace them.
  - ★ If the shift mechanism arm [D] is damaged in any way, replace the arm.

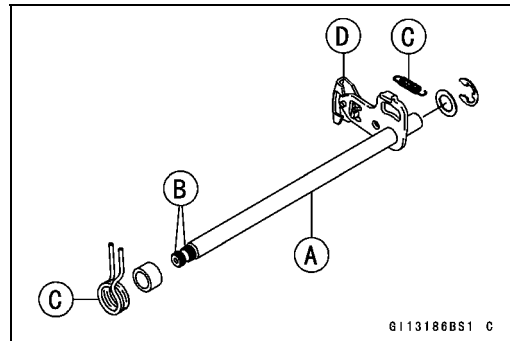

- Check the return spring pin [A] is not loose.
  - ★ If it is loose, unscrew it, apply a non-permanent locking agent to the threads, and tighten it.
    - Torque - Shift Shaft Return Spring Pin: 28 N·m (2.9 kgf·m, 21 ft·lb)**
- Check the gear positioning lever [B] and its spring for breaks or distortion.
  - ★ If the lever or spring are damaged in any way, replace them.
- Visually inspect the shift drum cam [C].
  - ★ If they are badly worn or if they show any damage, replace it.

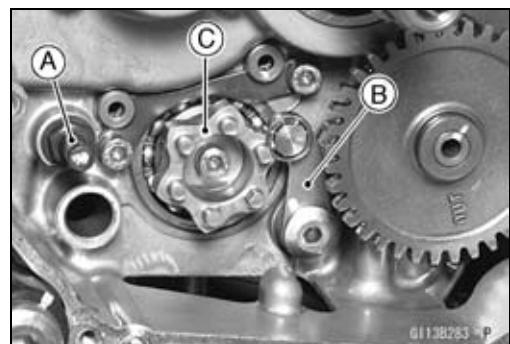

**Transmission**

*Transmission Shaft Removal*

- Split the crankcase (see Crankcase Splitting in this chapter).
- Remove the drive shaft [A] and output shaft [B].

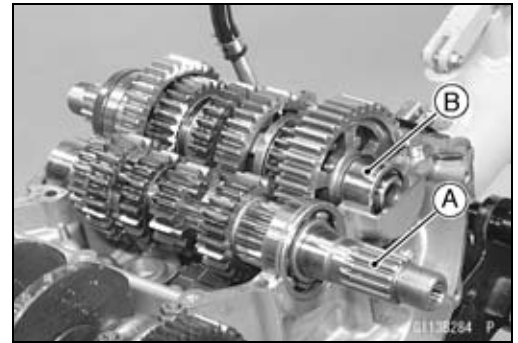

*Transmission Shaft Installation*

- Check to see that the set ring [A] and set pin [B] are in place.

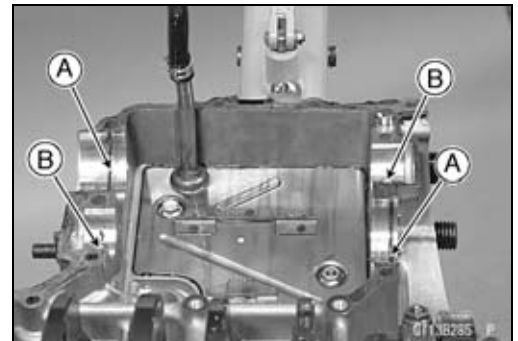

- Install the drive shaft and output shaft into the upper crankcase half.
- Apply molybdenum disulfide oil to the sliding surfaces of the gears and bearings.
- The bearing set pin and ring must match properly with the hole or groove in the bearing outer races. When they are properly matched, there is no clearance [A] between the crankcase and the bearing outer races.

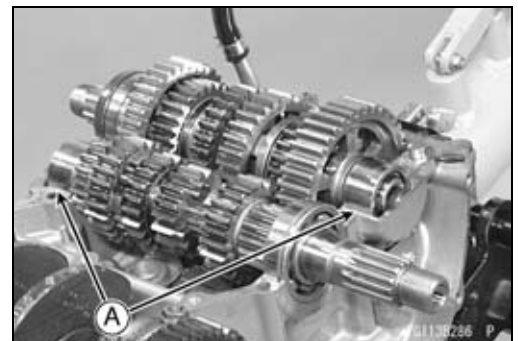

- Assemble the crankcase.
- Press in the oil seal [A] onto collar [B] so that the surface of the oil seal is flush with the counterbore bottom surface [C] of the crankcase.

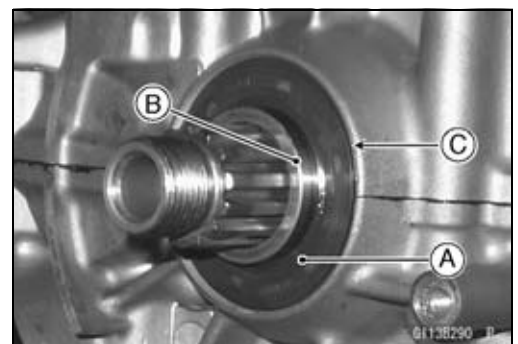

*Transmission Shaft Disassembly*

- Remove the transmission shafts (see Transmission Shaft Removal in this chapter).
- Remove the circlips, disassemble the transmission shafts.

**Special Tool - Outside Circlip Pliers: 57001-144**

- The 5th gear [A] on the output shaft has three steel balls assembled into it for the positive neutral finder mechanism. Remove the 5th gear.
- Set the output shaft in a vertical position holding the 3rd gear [C].
- Spin the 5th gear quickly [B] and pull it off upward.

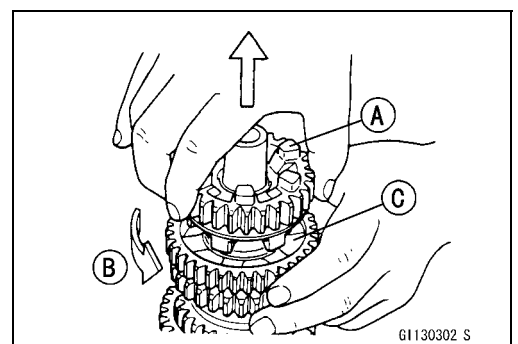

## 9-26 CRANKSHAFT/TRANSMISSION

### Transmission

- Remove the ball bearing [A] from each shafts.  
**Special Tools - Bearing Puller [B]: 57001-135**  
**Bearing Puller Adapter [C]: 57001-317**
- Discard the bearing.

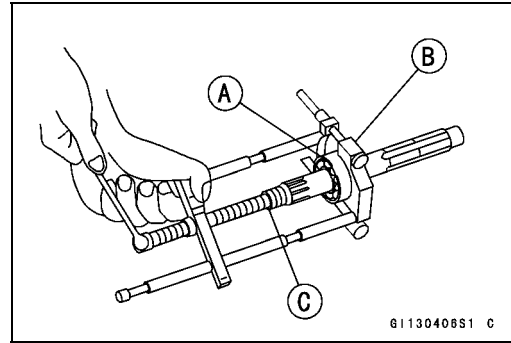

### Transmission Shaft Assembly

- Install the ball bearing on the drive shaft [A] with the groove [B] toward the clutch side using the bearing driver.
- Install the ball bearing and collar on the output shaft [C] using the bearing driver.
- Special Tool - Bearing Driver,  $\phi 32$ : 57001-382**

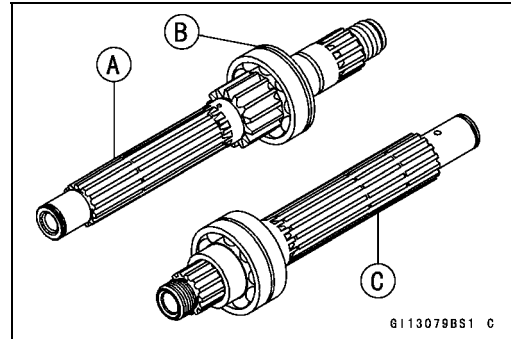

- Apply molybdenum disulfide oil to the sliding surfaces of the gears and shafts.
- Install the gear bushings [A] on the shaft with their holes [B] aligned.

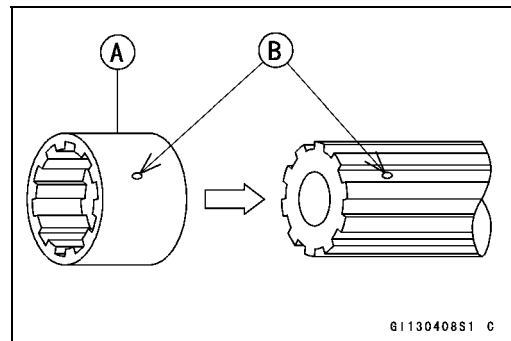

- Replace any circlips removed with new ones.
- Install the circlips [A] so that the opening [B] is aligned with a spline groove [C].
- Check that each gear spins or slides freely on the transmission shafts without binding after assembly.

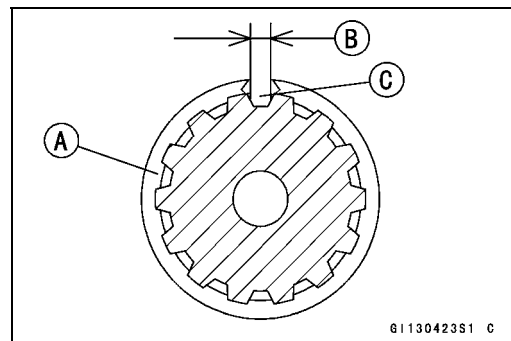

- The drive shaft gears can be recognized by size: the gear with the smallest diameter is 1st gear, and the largest one is 6th gear. Be sure that all parts are put back in the correct sequence and all circlips and washers are properly in place.
- Install the 3rd/4th gear onto the drive shaft with their oil holes aligned.
- The output shaft gears can be recognized by size: the gear with the largest diameter is 1st gear, and the smallest one is 6th gear. Be sure that all parts are put back in the correct sequence and all circlips and washers are properly in place.
- Install the 5th and 6th gears onto the output shaft with their oil holes aligned.

## Transmission

- Fit the steel balls into the 5th gear holes in the output shaft, aligning three oil holes.
  - 5th Gear [A]
  - Output Shaft [B]
  - Steel Balls [C]
  - Oil Holes [D]

### CAUTION

**Do not apply grease to the balls to hold them in place. This will cause the positive neutral finder mechanism to malfunction.**

- After assembling the 5th gear with steel balls in place on the output shaft, check the ball-locking effect that the 5th gear doesn't come out of the output shaft when moving it up and down by hand.
- Check that each gear spins or slides freely on the transmission shafts without binding after assembly.

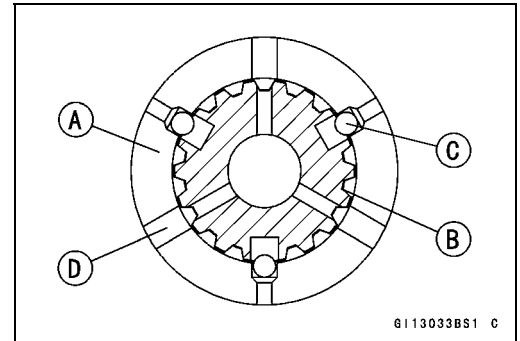

# 9-28 CRANKSHAFT/TRANSMISSION

## Transmission

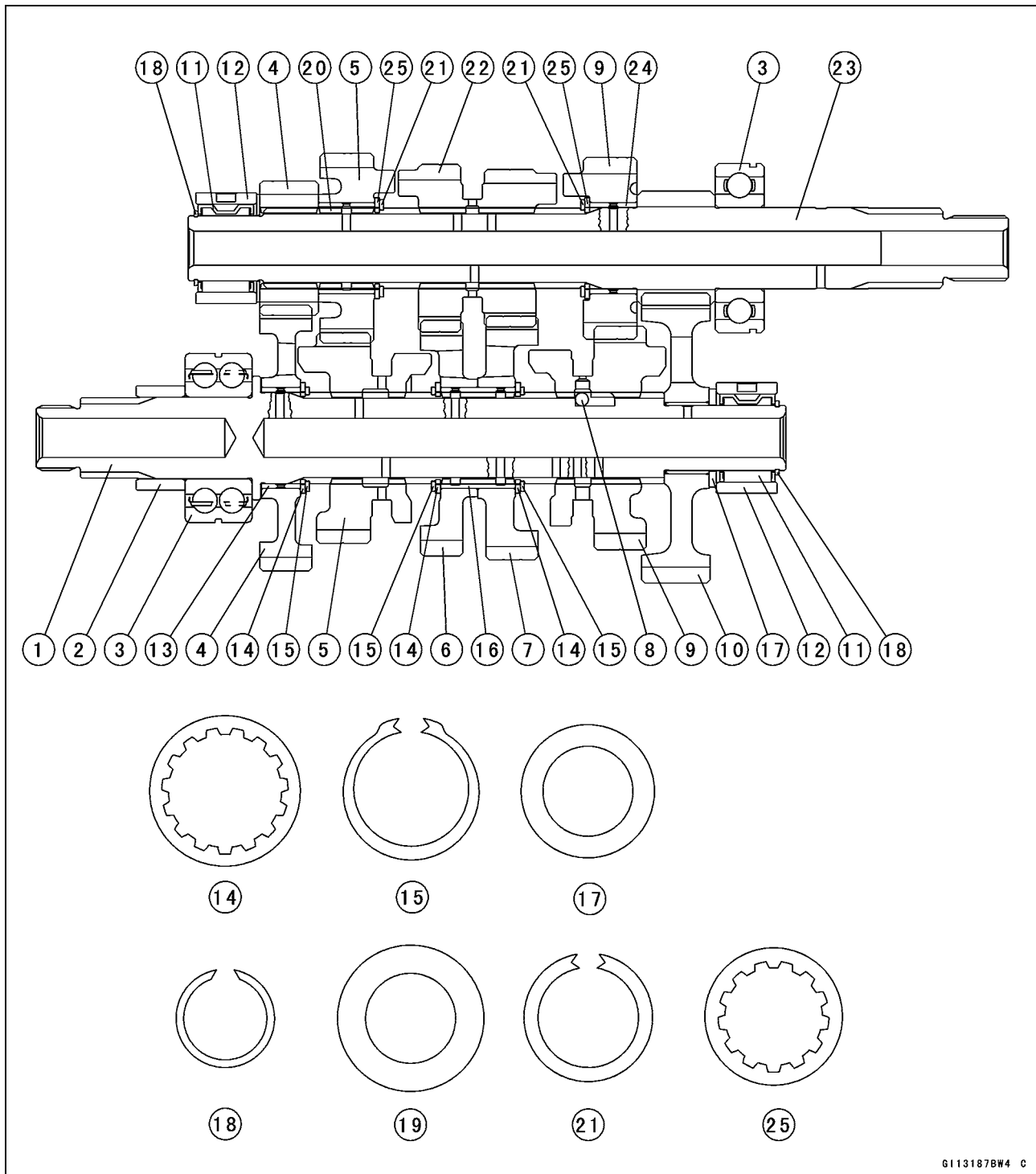

G113187B4 C

- |                        |   |
|------------------------|---|
| 1. Output Shaft        | 14. Toothed Washer, $\phi 34$ mm (1.34 in.) |
| 2. Collar              | 15. Snap Ring                               |
| 3. Ball Bearing        | 16. Bushing                                 |
| 4. 2nd Gear            | 17. Thrust Washer, $\phi 30$ mm (1.18 in.)  |
| 5. 6th (Top) Gear      | 18. Snap Ring                               |
| 6. 4th Gear            | 19. Thrust Washer, $\phi 33$ mm (1.30 in.)  |
| 7. 3rd Gear            | 20. Bushing                                 |
| 8. Steel Ball          | 21. Snap Ring                               |
| 9. 5th Gear            | 22. 3rd/4th Gear                            |
| 10. 1st Gear           | 23. Drive Shaft                             |
| 11. Needle Bearing     | 24. Bushing                                 |
| 12. Bearing Outer Race | 25. Toothed Washer, $\phi 31$ mm (1.22 in.) |
| 13. Bushing            |   |

## Transmission

### Shift Drum and Fork Removal

- Remove:
  - Lower Crankcase Half (see Crankcase Splitting in this chapter)
  - External Shift Mechanism (see External Shift Mechanism Removal in this chapter)
  - Bolts [A]
  - Shift Drum Bearing Holder [B]
- Pull out the shift rods [C], and take off the shift forks.
- Pull out the shift drum [D].

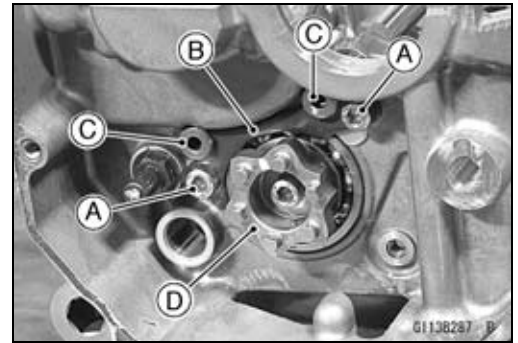

### Shift Drum and Fork Installation

- Apply engine oil to the shift drum, forks and rods.
- Install the shift rods [A], noting the groove position.
- Install the forks as shown.
- Position the one with shortest ears [B] on the drive shaft and place the pin in the center groove in the shift drum [C].
- The two forks [D] on the output shaft are identical.
- Engage the shift drum bearing holder to the groove of the shift rod, and apply a non-permanent locking agent to the threads of the holder bolts, and tighten them.

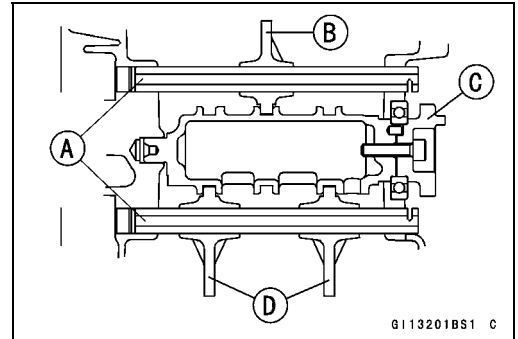

**Torque - Shift Drum Bearing Holder Bolts: 12 N·m (1.2 kgf·m, 104 in·lb)**

### Shift Drum Disassembly

- Remove the shift drum (see Shift Drum and Fork Removal in this chapter).
- While holding the shift drum with a vise, remove the shift drum cam holder bolt.
  - Shift Drum Cam Holder Bolt [A]
  - Dowel Pin [B]

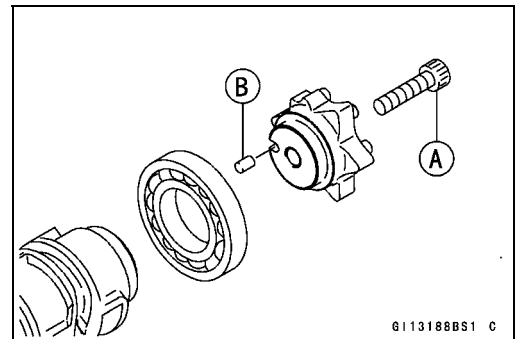

### Shift Drum Assembly

- Be sure to install the dowel pin.
- Apply a non-permanent locking agent to the threads of the shift drum cam holder bolt, and tighten it.

**Torque - Shift Drum Cam Holder Bolt: 12 N·m (1.2 kgf·m, 104 in·lb)**

### Shift Fork Bending

- Visually inspect the shift forks, and replace any fork that is bent. A bent fork could cause difficulty in shifting, or allow the transmission to jump out of gear when under power.
  - 90° [A]

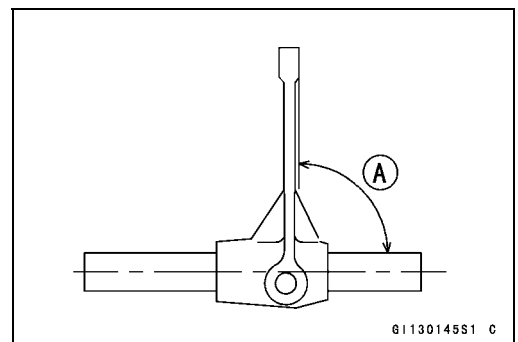

# 9-30 CRANKSHAFT/TRANSMISSION

## Transmission

### Shift Fork/Gear Groove Wear

- Measure the thickness of the shift fork ears [A], and measure the width [B] of the gear grooves.
- ★ If the thickness of a shift fork ear is less than the service limit, the shift fork must be replaced.

#### Shift Fork Ear Thickness

**Standard:** 5.9 ~ 6.0 mm (0.232 ~ 0.236 in.)

**Service Limit:** 5.8 mm (0.228 in.)

- ★ If the gear groove is worn over the service limit, the gear must be replaced.

#### Gear Groove Width

**Standard:** 6.05 ~ 6.15 mm (0.238 ~ 0.242 in.)

**Service Limit:** 6.25 mm (0.246 in.)

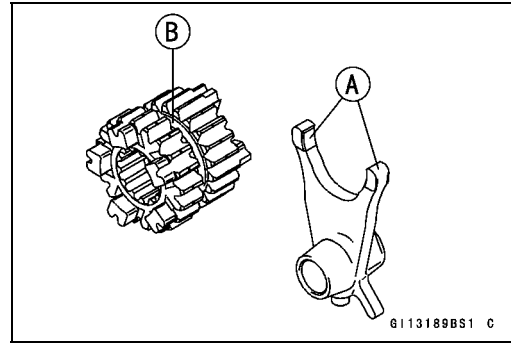

### Shift Fork Guide Pin/Drum Groove Wear

- Measure the diameter of each shift fork guide pin [A], and measure the width [B] of each shift drum groove.
- ★ If the guide pin on any shift fork is less than the service limit, the fork must be replaced.

#### Shift Fork Guide Pin Diameter

**Standard:** 5.9 ~ 6.0 mm (0.232 ~ 0.236 in.)

**Service Limit:** 5.8 mm (0.228 in.)

- ★ If any shift drum groove is worn over the service limit, the drum must be replaced.

#### Shift Drum Groove Width

**Standard:** 6.05 ~ 6.20 mm (0.238 ~ 0.244 in.)

**Service Limit:** 6.3 mm (0.248 in.)

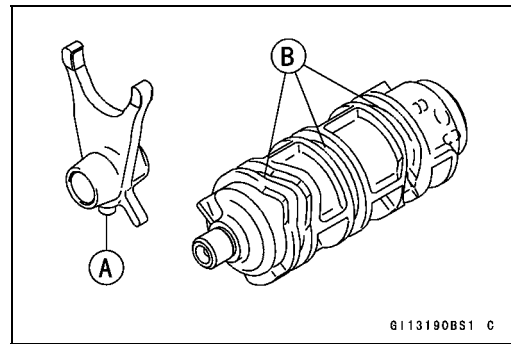

### Gear Dog and Gear Dog Hole Damage

- Visually inspect the gear dogs [A] and gear dog holes [B].
- ★ Replace any damaged gears or gears with excessively worn dogs or dog holes.

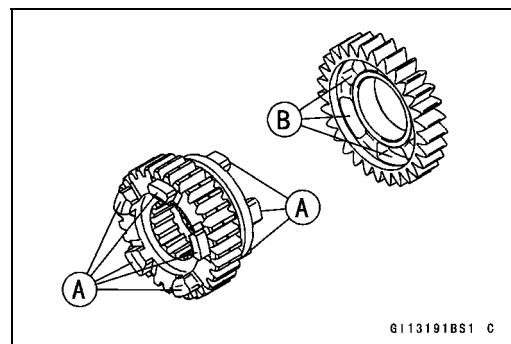

# Wheels/Tires

## Table of Contents

Exploded View .....	10-2
Specifications .....	10-4
Special Tools .....	10-5
Wheels (Rims) .....	10-6
Front Wheel Removal .....	10-6
Front Wheel Installation .....	10-6
Rear Wheel Removal .....	10-7
Rear Wheel Installation .....	10-8
Wheel Inspection .....	10-10
Axle Inspection .....	10-10
Balance Inspection .....	10-11
Balance Adjustment .....	10-11
Balance Weight Removal .....	10-11
Balance Weight Installation .....	10-11
Tires .....	10-13
Air Pressure Inspection/Adjustment .....	10-13
Tire Inspection .....	10-13
Tire Removal .....	10-13
Tire Installation .....	10-13
Tire Repair .....	10-15
Hub Bearing .....	10-16
Hub Bearing Removal .....	10-16
Hub Bearing Installation .....	10-16
Hub Bearing Inspection .....	10-16
Hub Bearing Lubrication .....	10-17

# 10-2 WHEELS/TIRES

## Exploded View

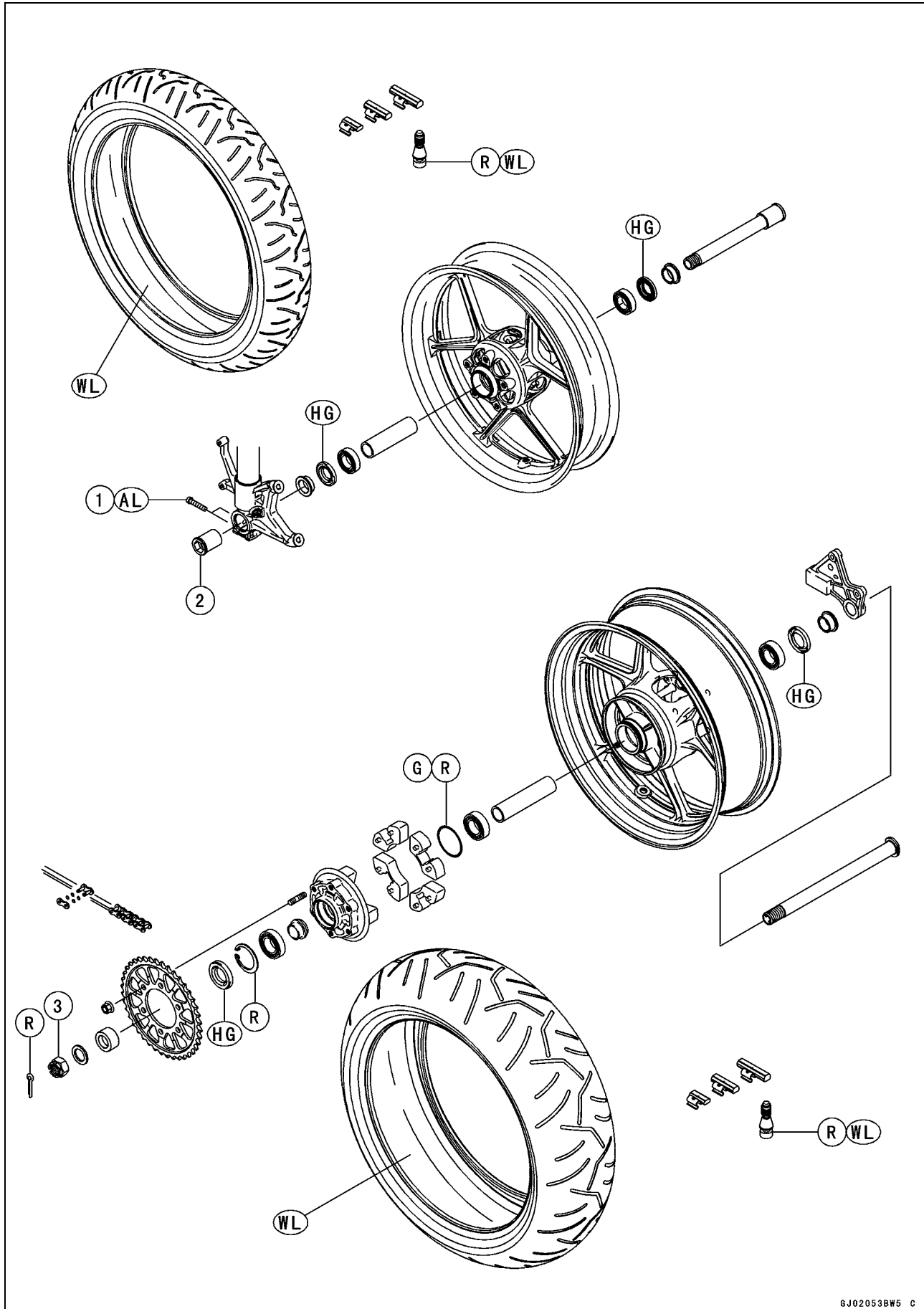

**Exploded View**

<b>No.</b>	<b>Fastener</b>	<b>Torque</b>			<b>Remarks</b>
		<b>N·m</b>	<b>kgf·m</b>	<b>ft·lb</b>	
1	Front Axle Clamp Bolts	20	2.0	15	AL
2	Front Axle Nut	127	13	94	
3	Rear Axle Nut	127	13	94	

AL: Tighten the two clamp bolts alternately two time to ensure even tightening.

G: Apply grease.

HG: Apply high-temperature grease.

R: Replacement Parts

WL: Apply soap and water solution or rubber lubricant.

## 10-4 WHEELS/TIRES

### Specifications

Item	Standard	Service Limit
<b>Wheels (Rims)</b>		
Rim Runout:		
Axial	---	0.5 mm (0.02 in.)
Radial	---	0.8 mm (0.03 in.)
Axle Runout/100 mm	0.05 mm (0.002 in.) or less	0.2 mm (0.01 in.)
Wheel Balance	10 g (0.35 oz.) or less	---
Balance Weights	10 g (0.35 oz.), 20 g (0.71 oz.), 30 g (1.06 oz.)	---
<b>Tires</b>		
Air Pressure (when Cold):		
Front	Up to 180 kg (396 lb) load: 250 kPa (2.5 kgf/cm <sup>2</sup> , 36 psi)	---
Rear	Up to 180 kg (396 lb) load: 290 kPa (2.9 kgf/cm <sup>2</sup> , 41 psi)	---
Tread Depth:		
Front	3.6 mm (0.14 in.)	1 mm (0.04 in.) (AT, CH, DE) 1.6 mm (0.06 in.)
Rear	5.8 mm (0.23 in.)	Up to 130 km/h (80 mph): 2 mm (0.08 in.) Over 130 km/h (80 mph): 3 mm (0.12 in.)
Standard Tires:	Make, Type	Size
Front	BRIDGESTONE, BATTLEAX BT014F RADIAL J	120/65 ZR17 M/C (56 W)
Rear	BRIDGESTONE, BATTLEAX BT014R RADIAL J	180/55 ZR17 M/C (73 W)

AT: Australia

CH: Switzerland

DE: Germany

### WARNING

Use the same manufacturer's tires on both front and rear wheels.

Special Tools

Bearing Driver Set:  
57001-1129

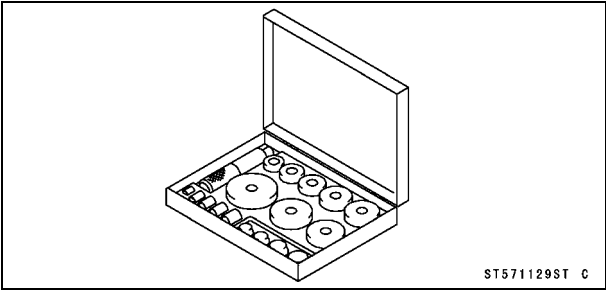

ST571129ST C

Bearing Remover Shaft,  $\phi 13$ :  
57001-1377

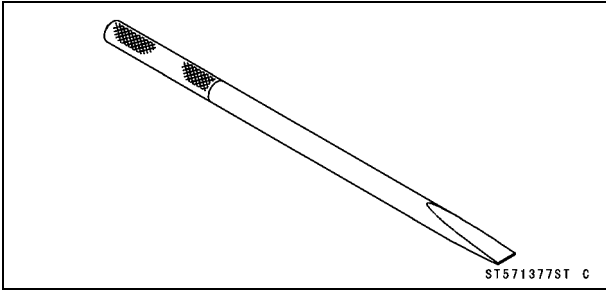

ST571377ST C

Jack:  
57001-1238

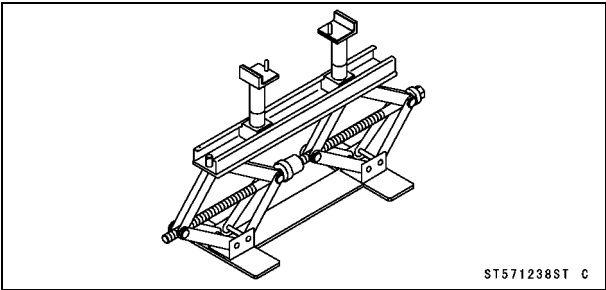

ST571238ST C

Jack Attachment:  
57001-1608

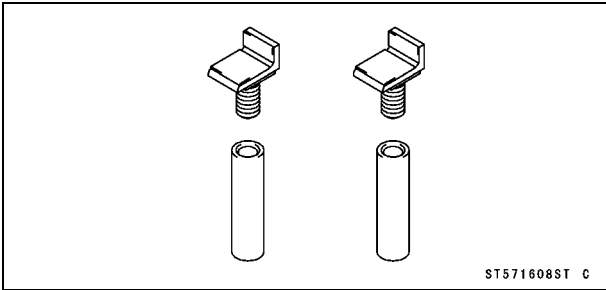

ST571608ST C

Bearing Remover Head,  $\phi 25 \times \phi 28$ :  
57001-1346

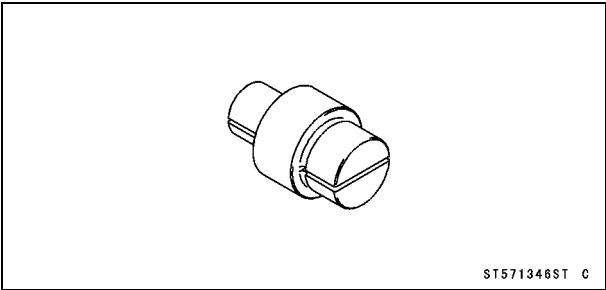

ST571346ST C

## 10-6 WHEELS/TIRES

### Wheels (Rims)

#### Front Wheel Removal

- Remove:
  - Brake Caliper Mounting Bolts [A]
  - Front Brake Calipers [B]
  
- Loosen:
  - Axle Clamp Bolts [A] (Left Side)
  - Axle Nut [B]
  - Axle Clamp Bolts (Right Side)
  
- Remove the lower fairings (see Lower Fairing Removal in the Frame chapter).
- Raise the front wheel off the ground.
  - Special Tools - Jack: 57001-1238**
  - Jack Attachment: 57001-1608**
- Remove the axle nut and pull out the axle to the right and drop the front wheel out of the forks.

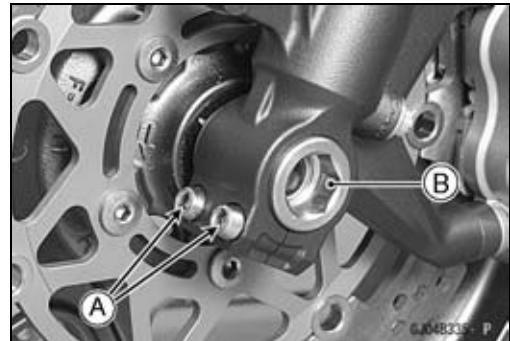
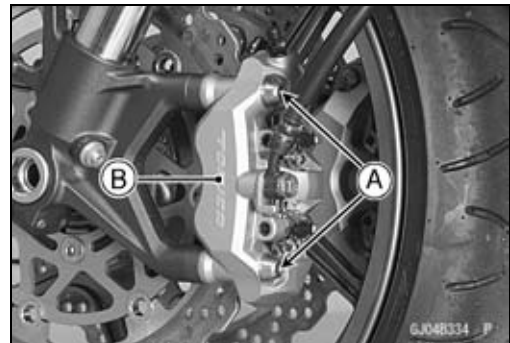

#### CAUTION

**Do not lay the wheel down on one of the discs. This can damage or warp the disc. Place blocks under the wheel so that the disc does not touch the ground.**

#### Front Wheel Installation

##### NOTE

- The direction of the wheel rotation [A] is shown by an arrow [B] on the wheel spoke.
- Check the wheel rotation mark on the front wheel and install it.

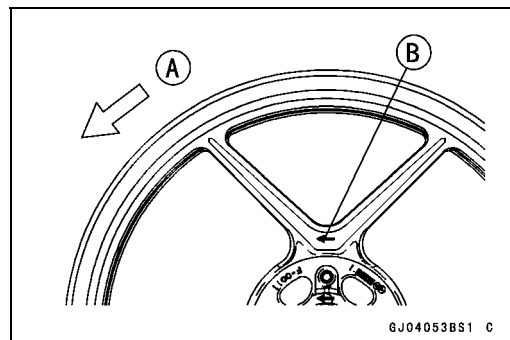

## Wheels (Rims)

- Apply high-temperature grease to the grease seal lip.
- Fit the collars [A] on the both sides of the hub.
- The collars are identical.
- Insert the axle.
- Tighten the axle nut [B].
- Right Axle Clamp Bolts [C]
- Left Axle Clamp Bolts [D]
- Viewed from Rear [E]

**Torque - Front Axle Nut: 127 N·m (13 kgf·m, 94 ft·lb)**

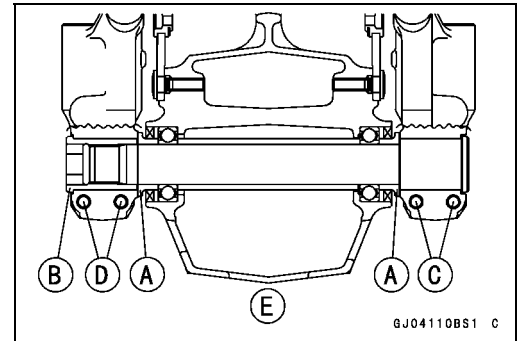

- Before tightening the axle clamp bolts on the right front fork leg, pump the front fork up and down [A] 4 or 5 times to all on the right front fork leg to seat on the front axle.

### NOTE

- Put a block in front of the front wheel to stop moving.
- Tighten the two clamp bolts alternately two times to ensure even tightening torque.

- Tighten the axle clamp bolts on the right fork leg first. Next, tighten the left axle clamp bolts.

**Torque - Front Axle Clamp Bolts: 20 N·m (2.0 kgf·m, 15 ft·lb)**



### NOTE

- Tighten the two clamp bolts alternately two times to ensure even tightening torque.

- Install the front brake calipers (see Caliper Installation in the Brakes chapter).
- Check the front brake effectiveness (see Brake Operation Inspection in the Periodic Maintenance chapter).

## ⚠ WARNING

**Do not attempt to drive the motorcycle until a full brake lever is obtained by pumping the brake lever until the pads are against the disc. The brake will not function on the first application of the lever if this is not done.**

### Rear Wheel Removal

- Raise the rear wheel off the ground with the stand [A].



## 10-8 WHEELS/TIRES

### Wheels (Rims)

- Remove:  
Rear Caliper Mounting Bolts [A]  
Rear Caliper [B]

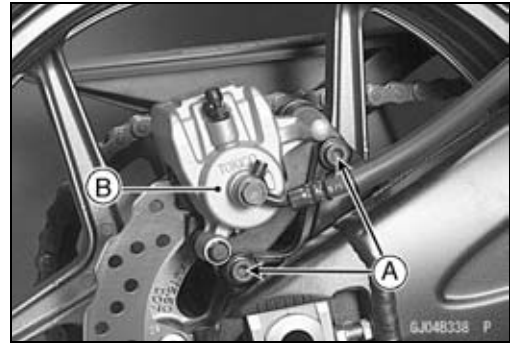

- Remove:  
Cotter Pin [A]  
Axle Nut [B]  
Axle [C] (from Right Side)

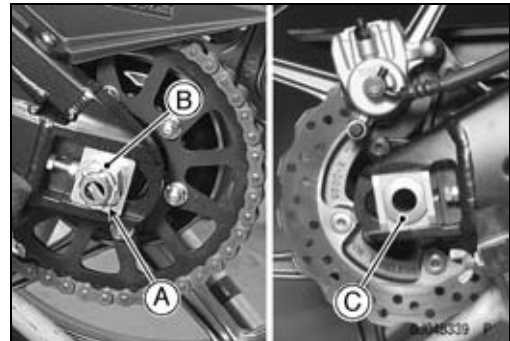

- Remove the drive chain [A] from the rear sprocket toward the left.
- Move the rear wheel back and remove it.



#### CAUTION

**Do not lay the wheel on the ground with the disc facing down. This can damage or warp the disc. Place blocks under the wheel so that the disc does not touch the ground.**

#### Rear Wheel Installation

- Fit the collars on the both sides of the hub.  
Right Side Collar [A] (with Flange)  
Left Side Collar [B]

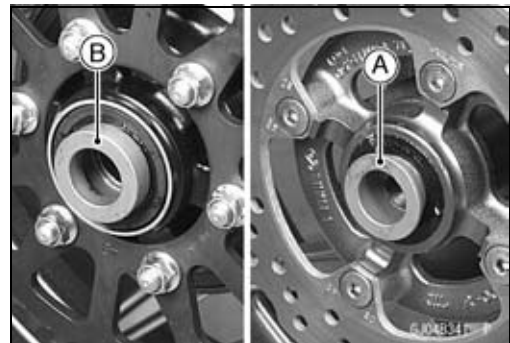

○ If the coupling [A] is removed from the rear wheel, apply the grease as shown.

- Wheel Flange Portion [B]
- O-ring [C]

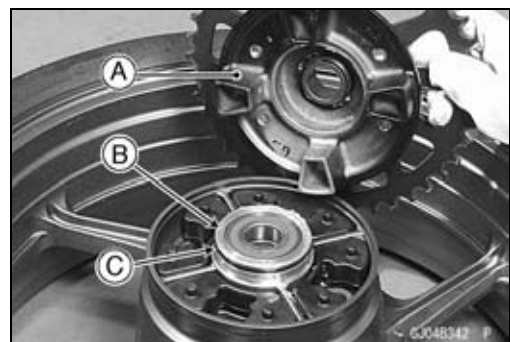

## Wheels (Rims)

- Engage the drive chain with the rear sprocket.
- Install the caliper bracket [A] onto the swingarm stop [B].
- Insert the axle from the right side of the wheel, and tighten the axle nut.

**Torque - Rear Axle Nut: 127 N·m (13 kgf·m, 94 ft·lb)**

- Adjust the drive chain slack after installation (see Drive Chain Slack Inspection in the Periodic Maintenance chapter).

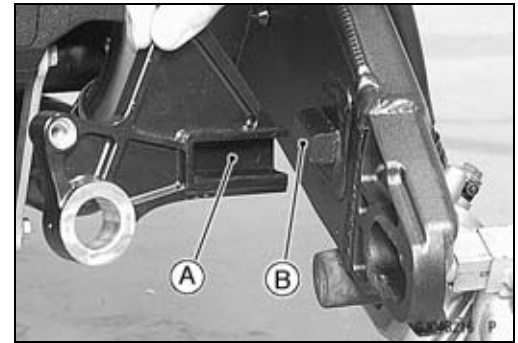

- Insert a new cotter pin [A].

### NOTE

- When inserting the cotter pin, if the slots in the nut do not align with the cotter pin hole in the axle, tighten the nut clockwise [B] up to next alignment.
- It should be within 30°.
- Loosen once and tighten again when the slot goes past the nearest hole.

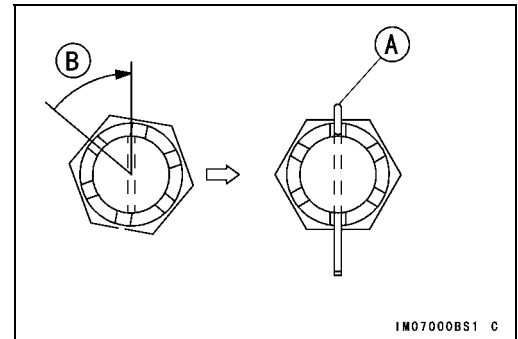

- Install the rear caliper and chain cover (see appropriate chapters).
- Check the rear brake effectiveness (see Brake Operation Inspection in the Periodic Maintenance chapter).

### ⚠ WARNING

Do not attempt to drive the motorcycle until a full brake pedal is obtained by pumping the brake pedal until the pads are against the disc. The brake will not function on the first application of the pedal if this is not done.

- Bend the cotter pin [A] over the nut.

### ⚠ WARNING

If the rear axle nut is not securely tightened or the cotter pin is not installed, an unsafe riding condition may result.

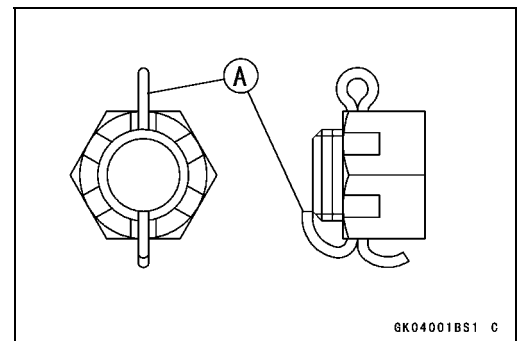

# 10-10 WHEELS/TIRES

## Wheels (Rims)

### Wheel Inspection

- Raise the front/rear wheel off the ground.

**Special Tools - Jack: 57001-1238**

**Jack Attachment: 57001-1608**

- Spin the wheel lightly, and check for roughness or binding.
- ★ If roughness or binding is found, replace the hub bearings (see Hub Bearing Removal/Installation in this chapter).
- Inspect the wheel for small cracks, dents, bending, or warp.
- ★ If there is any damage to the wheel, replace the wheel.
- Remove the wheel, and support it without the tire by the axle.
- Measure the rim runout, radial [A] and axial [B], with a dial gauge.
- ★ If rim runout exceeds the service limit, check the hub bearings (see Hub Bearing Inspection in this chapter).
- ★ If the problem is not due to the bearings, replace the wheel.

### Rim Runout

#### Service Limit:

Axial	0.5 mm (0.02 in.)
Radial	0.8 mm (0.03 in.)

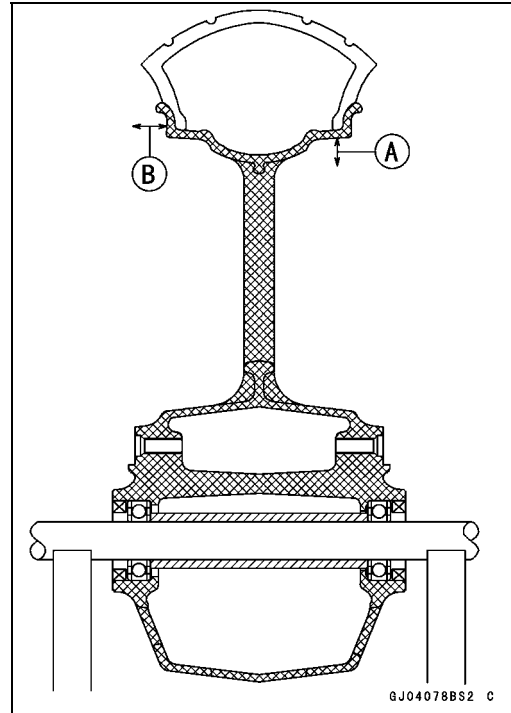

## ⚠ WARNING

**Never attempt to repair a damaged wheel. If there is any damage besides wheel bearings, the wheel must be replaced to insure safe operational condition.**

### Axle Inspection

- Remove the front and rear axles (see Front/Rear Wheel Removal in this chapter).
- Visually inspect the front and rear axle for damages.
- ★ If the axle is damaged or bent, replace it.
- Place the axle in V blocks that are 100 mm (3.94 in.) [A] apart, and set a dial gauge [B] on the axle at a point halfway between the blocks. Turn [C] the axle to measure the runout. The difference between the highest and lowest dial readings is the amount of runout.
- ★ If axle runout exceeds the service limit, replace the axle.

### Axle Runout/100 mm (3.94 in.)

Standard:	0.05 mm (0.002 in.) or less
Service Limit:	0.2 mm (0.01 in.)

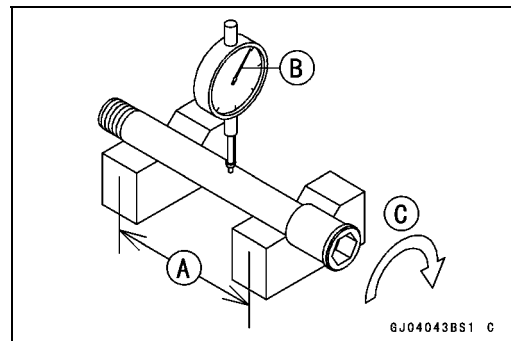

## Wheels (Rims)

### Balance Inspection

- Remove the front and rear wheels (see Front/Rear Wheel Removal in this chapter).
- Support the wheel so that it can be spun freely.
- Spin the wheel lightly, and mark [A] the wheel at the top when the wheel stops.
- Repeat this procedure several times. If the wheel stops of its own accord in various positions, it is well balanced.
- ★ If the wheel always stops in one position, adjust the wheel balance (see Balance Adjustment in this chapter).

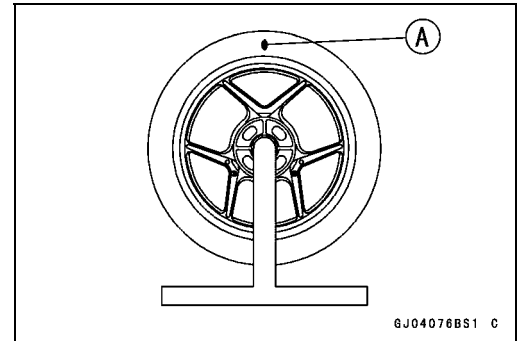

### Balance Adjustment

- If the wheel always stops in one position, provisionally attach a balance weight [A] on the rim at the marking using adhesive tape.
- Rotate the wheel 1/4 turn [B], and see whether or not the wheel stops in this position. If it does, the correct balance weight is being used.
- ★ If the wheel rotates and the weight goes up, replace the weight with the next heavier size. If the wheel rotates and the weight goes down, replace the weight with the next lighter size. Repeat these steps until the wheel remains at rest after being rotated 1/4 turn.
- Rotate the wheel another 1/4 turn and then another 1/4 turn to see if the wheel is correctly balanced.
- Repeat the entire procedure as many times as necessary to achieve correct wheel balance.
- Permanently install the balance weight.

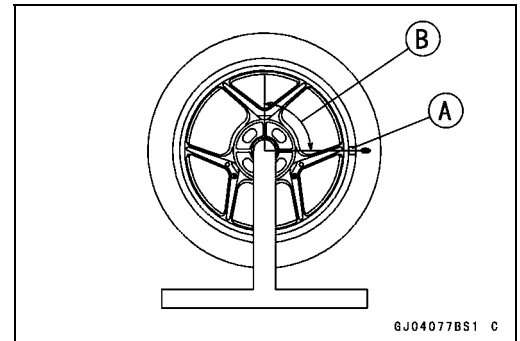

### Balance Weight Removal

- Insert a regular tip screw drivers [A] [B] between the rib [C] and weight [D] as shown.
- Pry the balance weight with two screw drivers and remove the balance weight.
- Discard the used balance weight.

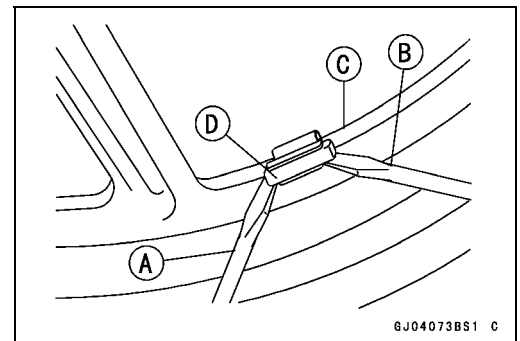

### CAUTION

**Do not tap the screwdrivers. The rim could be damaged.**

### Balance Weight Installation

- Check if the weight portion has any play on the blade [A] and clip [B].
- ★ If it does, discard it.

### WARNING

**If the balance weight has any play on the rib of the rim, the blade and/or clip have been stretched. Replace the loose balance weight. Do not reuse used balance weight. Unbalanced wheels can create an unsafe riding condition.**

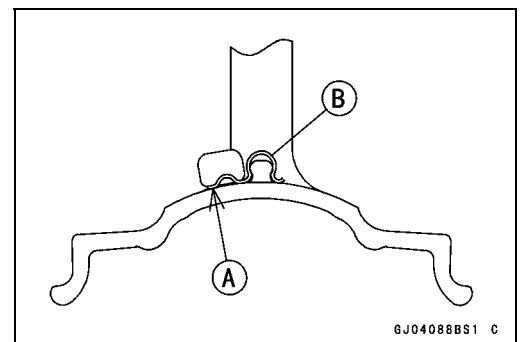

# 10-12 WHEELS/TIRES

## Wheels (Rims)

### Balance Weight

Part Number	Weight
41075-0007	10 g (0.35 oz)
41075-0008	20 g (0.71 oz)
41075-0009	30 g (1.06 oz)

### NOTE

- Balance weights are available from Kawasaki dealers in 10, 20, and 30 gram (0.35 oz, 0.71 oz, and 1.06 oz) sizes. An imbalance of less than 10 grams (0.35 oz) will not usually affect running stability.
- Do not use four or more balance weight (more than 90 gram, 3.2 oz). If the wheel requires an excess balance weight, disassemble the wheel to find the cause.

- Slip the balance weight [A] on to the rib [B], by pushing or lightly hammering [C] the clip [D].

Left Side [E]  
Right Side [F]

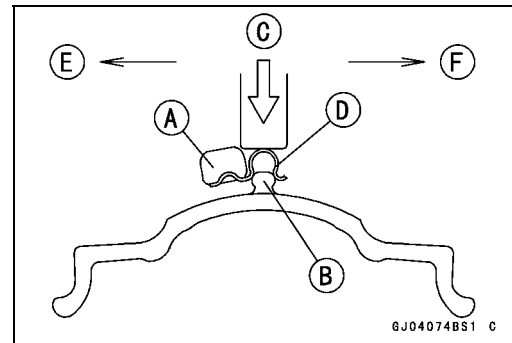

- Be sure to install the balance weight.
- Check that the blade [A] and clip [B] are fully seated on the rim [C] and that the clip is hooked over the rib [D].

Left Side [E]  
Right Side [F]

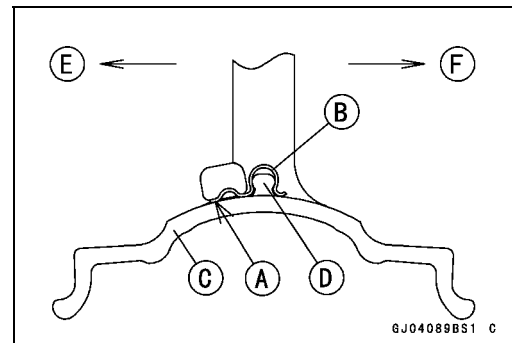

## Tires

### Air Pressure Inspection/Adjustment

- Refer to the Air Pressure Inspection in the Periodic Maintenance chapter.

### Tire Inspection

- Refer to the Wheel/Tire Damage Inspection in the Periodic Maintenance chapter.

### Tire Removal

- Remove:
  - Wheel (see Front/Rear Wheel Removal in this chapter)
  - Valve Core (Let out the air)
- To maintain wheel balance, mark the valve stem position on the tire with chalk so that the tire can be reinstalled in the same position.
  - Chalk Mark or Yellow Mark [A]
  - Air Valve [B]
  - Align [C]

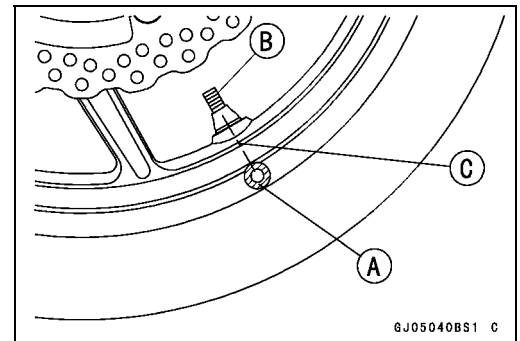

- Lubricate the tire beads and rim flanges on both sides with a soap and water solution or rubber lubricant. This helps the tire beads slip off the rim flanges.

### CAUTION

**Never lubricate with engine oil or petroleum distillates because they will deteriorate the tire.**

- Remove the tire from the rim using a suitable commercially available tire changer.

### NOTE

○ *The tires cannot be removed with hand tools because they fit the rims too tightly.*

### Tire Installation

### ⚠ WARNING

**Use the same manufacturer's on both front and rear wheels.**

- Inspect the rim and tire, and replace them if necessary.
- Clean the sealing surfaces of the rim and tire, and smooth the sealing surfaces of the rim with a fine emery cloth if necessary.
- Remove the air valve and discard it.

### CAUTION

**Replace the air valve whenever the tire is replaced. Do not reuse the air valve.**

## 10-14 WHEELS/TIRES

### Tires

- Install a new valve in the rim.
- Remove the valve cap, lubricate the stem seal [A] with a soap and water solution or rubber lubricant, and pull [B] the valve stem through the rim from the inside out until it snaps into place.

#### CAUTION

**Do not use engine oil or petroleum distillates to lubricate the stem because they will deteriorate the rubber.**

- The air valve is shown in the figure.

Valve Cap [A]  
Valve Core [B]  
Stem Seal [C]  
Valve Stem [D]  
Valve Seat [E]  
Valve Opened [F]

- Check the tire rotation mark on the front and rear tires and install them on the rim accordingly.  
Tire Rotation Mark [A]  
Rotating Direction [B]

- Position the tire on the rim so that the valve [A] align with the tire balance mark [B] (the chalk mark made during removal, or the yellow paint mark on a new tire).
- Install the tire bead over the rim flange using a suitable commercially available tire changer.
- Lubricate the tire beads and rim flanges with a soap and water solution or rubber lubricant to help seat the tire beads in the sealing surfaces of the rim while inflating the tire.
- Center the rim in the tire beads, and inflate the tire with compressed air until the tire beads seat in the sealing surfaces.

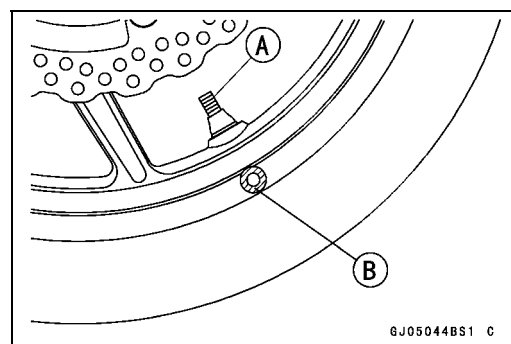
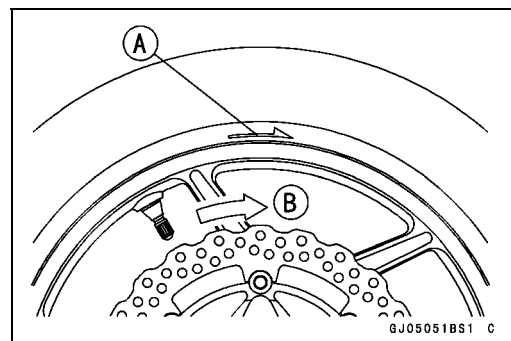
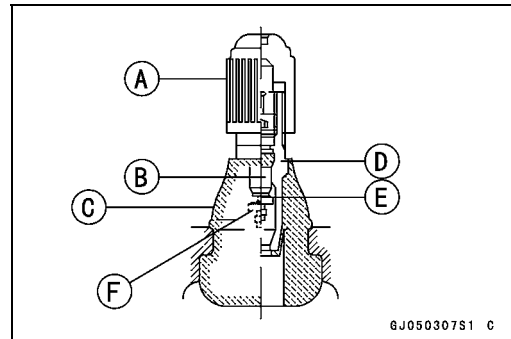
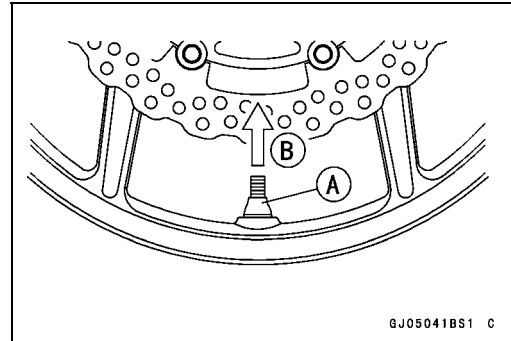

#### WARNING

**Be sure to install the valve core whenever inflating the tire, and do not inflate the tire to more than 400 kPa (4.0 kgf/cm<sup>2</sup>, 57 psi). Overinflation can explode the tire with possibility of injury and loss of life.**

## Tires

- Check to see that the rim lines [A] on both sides of the tire sidewalls are parallel with the rim flanges.
- ★ If the rim flanges and tire sidewall rim lines are not parallel, remove the valve core.
- Lubricate the rim flanges and tire beads.
- Install the valve core and inflate the tire again.
- After the tire beads seat in the rim flanges, check for air leakage.
- Inflate the tire slightly above standard inflation.
- Use a soap and water solution or submerge the tire, and check for bubbles that would indicate leakage.
- Adjust the air pressure to the specified pressure (see Air Pressure Inspection in the Periodic Maintenance chapter).
- Install the air valve cap.
- Adjust the wheel balance (see Balance Adjustment in this chapter).

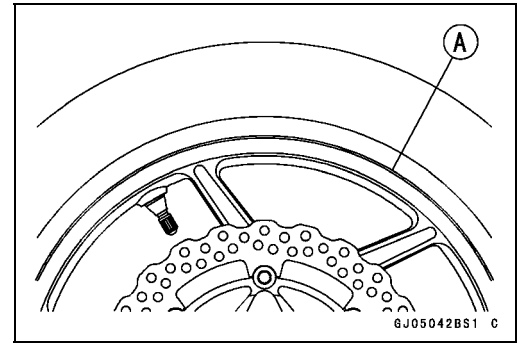

### *Tire Repair*

Currently two types of repair for tubeless tires have come into wide use. One type is called a temporary (external) repair which can be carried out without removing the tire from the rim, and the other type is called permanent (internal) repair which requires tire removal. It is generally understood that higher running durability is obtained by permanent (internal) repairs than by temporary (external) ones. Also, permanent (internal) repairs have the advantage of permitting a thorough examination for secondary damage not visible from external inspection of the tire. For these reasons, Kawasaki does not recommend temporary (external) repair. Only appropriate permanent (internal) repairs are recommended. Repair methods may vary slightly from make to make. Follow the repair methods indicated by the manufacturer of the repair tools and materials so that safe results can be obtained.

## 10-16 WHEELS/TIRES

### Hub Bearing

#### Hub Bearing Removal

- Remove the wheel (see Front/Rear Wheel Removal in this chapter), and take out the following.

- Collars
- Coupling (Out of rear hub)
- Grease Seals

- Use the bearing remover to remove the hub bearing [A].

#### CAUTION

**Do not lay the wheel on the ground with the disc facing down. This can damage or warp the disc. Place blocks under the wheel so that the disc does not touch the ground.**

**Special Tools - Bearing Remover Head,  $\phi 25 \times \phi 28$  [C]: 57001-1346**

**Bearing Remover Shaft,  $\phi 13$  [B]: 57001-1377**

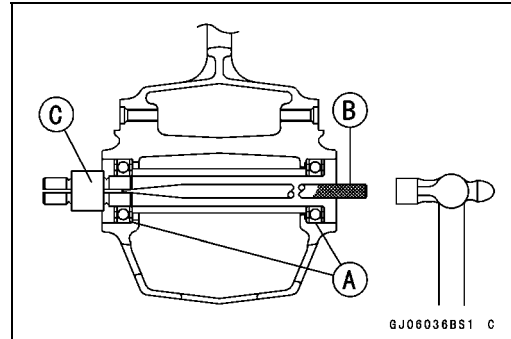

#### Hub Bearing Installation

- Before installing the hub bearings, blow any dirt or foreign particles out of the hub with compressed air to prevent contamination of the bearings.
- Replace the bearings with new ones.
- Install the bearings by using the bearing driver set which does not contact the bearing inner race.
- Press in each right the bearing [A] until they are bottomed.

**Special Tool - Bearing Driver Set [B]: 57001-1129**

- Replace the grease seals with new ones.
- Press in the grease seals [A] so that the seal surface is flush [B] with the end of the hole.
- Apply high-temperature grease to the grease seal lips.

**Special Tool - Bearing Driver Set [C]: 57001-1129**

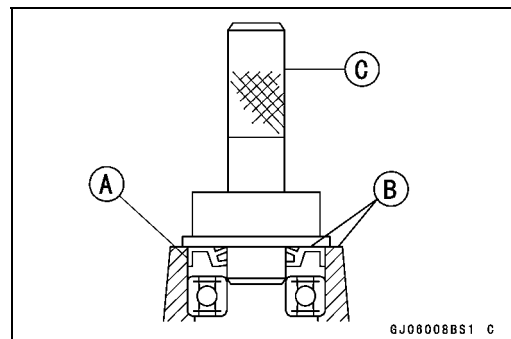
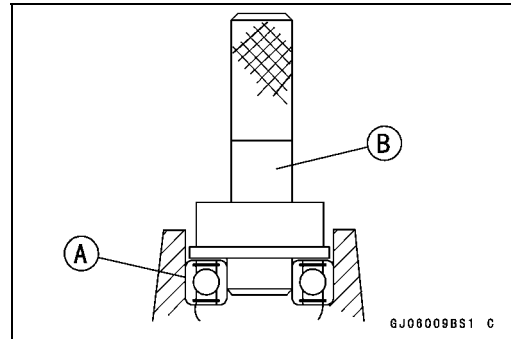

#### Hub Bearing Inspection

Since the hub bearings are made to extremely close tolerances, the clearance can not normally be measured.

#### NOTE

○ Do not remove any bearings for inspection. If any bearings are removed, they will need to be replaced with new ones.

- Turn each bearing in the hub back and forth [A] while checking for plays, roughness, or binding.
- ★ If bearing play, roughness, or binding is found, replace the bearing.
- Examine the bearing seal [B] for tears or leakage.
- ★ If the seal is torn or is leaking, replace the bearing.

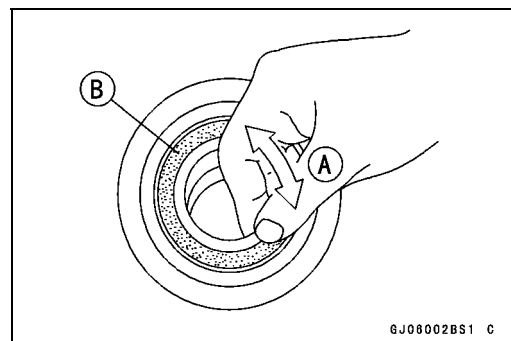

**Hub Bearing**

---

*Hub Bearing Lubrication*

**NOTE**

○ *Since the hub bearings are packed with grease and sealed, lubrication is not required.*



# Final Drive

## Table of Contents

- Exploded View ..... 11-2
- Specifications ..... 11-4
- Special Tools ..... 11-5
- Drive Chain..... 11-6
  - Drive Chain Slack Inspection ..... 11-6
  - Drive Chain Slack Adjustment ..... 11-6
  - Wheel Alignment Inspection/Adjustment ..... 11-6
  - Drive Chain Wear Inspection ..... 11-6
  - Drive Chain Lubrication..... 11-6
  - Drive Chain Removal ..... 11-6
  - Drive Chain Installation ..... 11-7
- Sprocket, Coupling ..... 11-10
  - Engine Sprocket Removal ..... 11-10
  - Engine Sprocket Installation ..... 11-10
  - Rear Sprocket Removal..... 11-11
  - Rear Sprocket Installation..... 11-11
  - Coupling Installation..... 11-11
  - Coupling Bearing Removal ..... 11-12
  - Coupling Bearing Installation ..... 11-12
  - Coupling Bearing Inspection ..... 11-13
  - Coupling Bearing Lubrication..... 11-13
  - Coupling Damper Inspection..... 11-13
  - Sprocket Wear Inspection..... 11-13
  - Rear Sprocket Warp Inspection ..... 11-14

# 11-2 FINAL DRIVE

## Exploded View

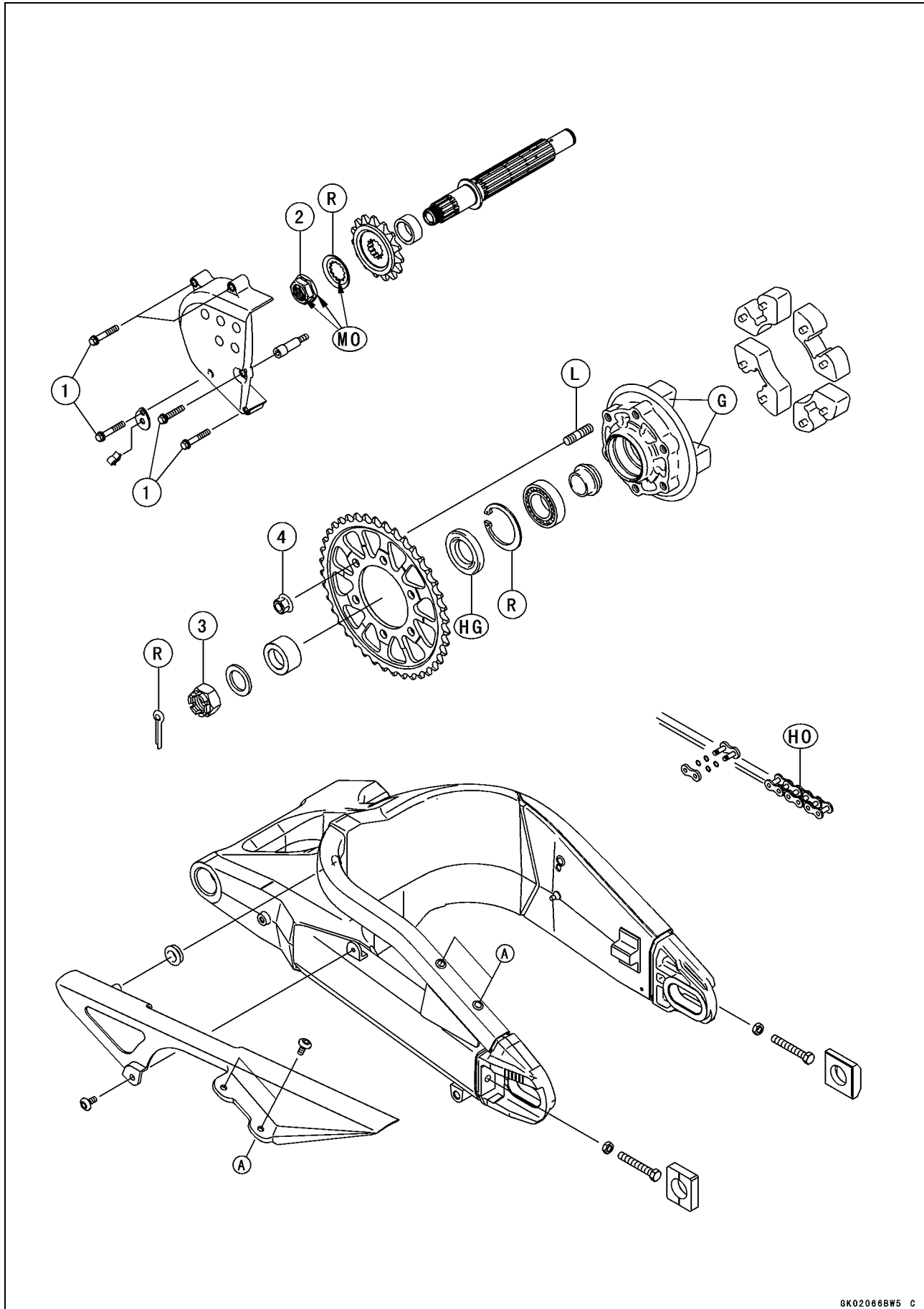

**Exploded View**

No.	Fastener	Torque			Remarks
		N·m	kgf·m	ft·lb	
1	Engine Sprocket Cover Bolts	6.9	0.70	61 in·lb	
2	Engine Sprocket Nut	125	13	92	MO
3	Rear Axle Nut	127	13	94	
4	Rear Sprocket Nuts	59	6.0	43	

G: Apply grease.

HG: Apply high-temperature grease.

HO: Apply heavy oil.

L: Apply a non-permanent locking agent.

MO: Apply molybdenum disulfide oil solution.

(mixture of the engine oil and molybdenum disulfide grease in a weight ratio 10 : 1)

R: Replacement Parts

## 11-4 FINAL DRIVE

### Specifications

Item	Standard	Service Limit
<b>Drive Chain</b> Standard Chain: Make Type Link	ENUMA EK520MVXL 110 links	- - - - - - - - -
<b>Sprockets</b> Rear Sprocket Warp	0.4 mm (0.016 in.) or less	0.5 mm (0.02 in.)

**Special Tools**

**Inside Circlip Pliers:**  
**57001-143**

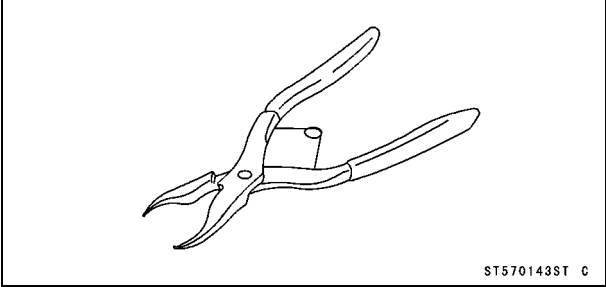

**Bearing Driver Set:**  
**57001-1129**

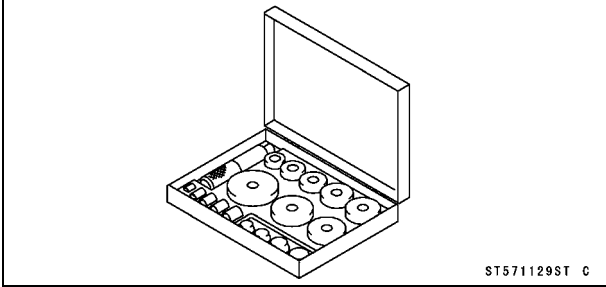

## 11-6 FINAL DRIVE

### Drive Chain

#### *Drive Chain Slack Inspection*

- Refer to the Drive Chain Slack Inspection in the Periodic Maintenance chapter.

#### *Drive Chain Slack Adjustment*

- Refer to the Drive Chain Slack Adjustment in the Periodic Maintenance chapter.

#### *Wheel Alignment Inspection/Adjustment*

- Refer to the Wheel Alignment Inspection in the Periodic Maintenance chapter.

#### *Drive Chain Wear Inspection*

- Refer to the Drive Chain Wear Inspection in the Periodic Maintenance chapter.

#### *Drive Chain Lubrication*

- Refer to the Drive Chain Lubrication Condition Inspection in the Periodic Maintenance chapter.

#### *Drive Chain Removal*

#### NOTE

○ Since the drive chain is installed through the swingarm, the chain cannot be removed other than by cutting it. Prepare the new link pin, link plate, grease seals, and tools for rejoining the chain.

- Using a suitable tool, cut the drive chain by removing the link pins.

**Recommended Tool: EK Joint Tool #50**

#### CAUTION

**Read the Tool Manual before removing.**

- Body [A]
- Handlebar [B]
- Cutting and Riveting Pin [C]
- For Cutting [D]
- For Riveting [E]
- Plate Holder (a) [F]
- Plate Holder (b) [G]
- Gauge [H]

- Grind [A] the pin head to make it flat.
- Set the cutting and riveting pin [B] as shown.

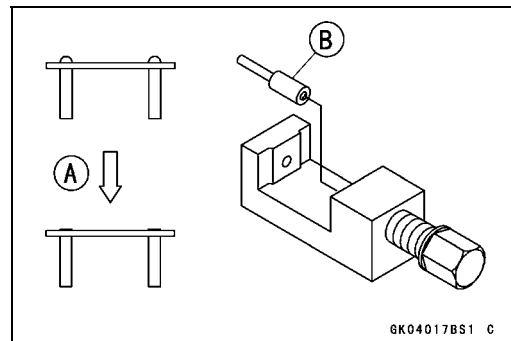
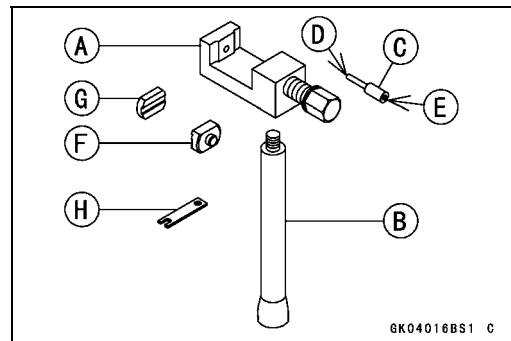

## Drive Chain

- Screw the pin holder until it touches chain pin.
- Be sure that the cutting pin hits center of chain pin.

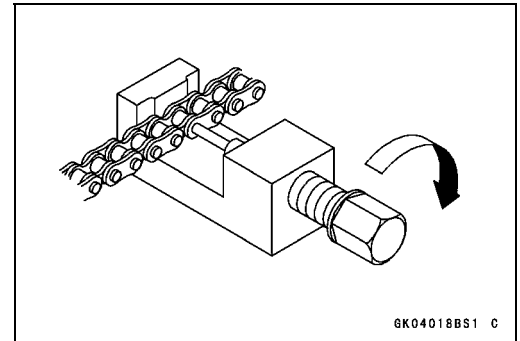

- Screw the handlebar [A] into body.
- Turn the pin holder with wrench [B] clockwise to extract chain pin.

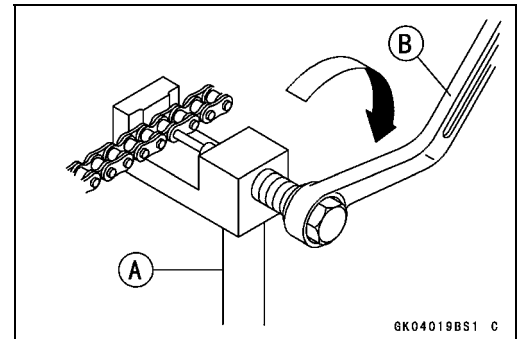

### Drive Chain Installation

- Engage the new drive chain to the old drive chain and pull the end of the old drive chain until they are changing the position.
  - Remove the old drive chain from the new drive chain.
  - Apply grease to the link pins [A] and grease seals [B] [C].
  - Engage the drive chain on the rear sprocket through the swingarm.
  - Insert the link pins in the drive chain ends.
  - Install the grease seals [C].
  - Install the link plate so that the mark [D] faces out.
  - Push the link plate by hand or plier to fix it.
  - In case of grease seal chain, be sure to set the grease seals correctly.
- Set the plate holder (a) [A] and plate holder (b) [B] on the body.

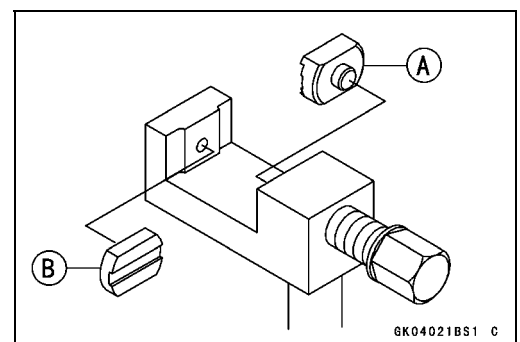
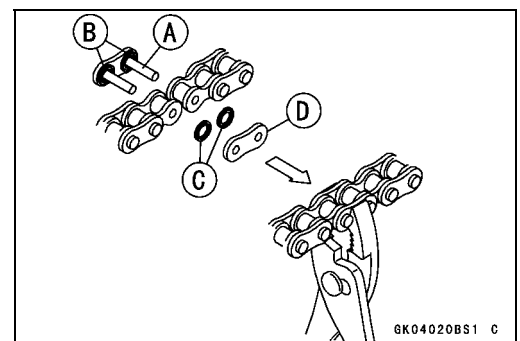

## 11-8 FINAL DRIVE

### Drive Chain

- Fit the plate holder (a) to link plate.
- Turn the pin holder by hand until plate holder (b) touches the other link plate.

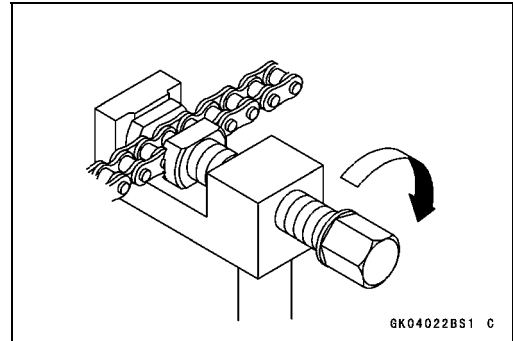

- Turn the pin holder by wrench clockwise until two pins of link come into groove of plate holder (a).
- Take off the plate holder (a).

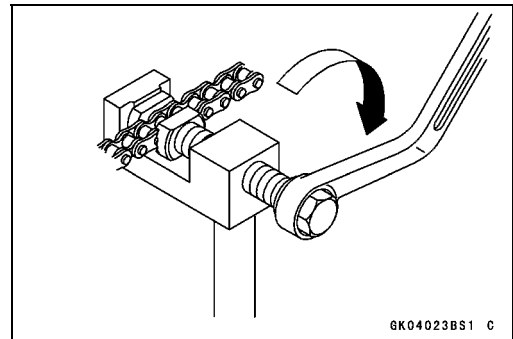

- Set the plate holder (b) [A] and cutting and riveting pin [B] as shown.

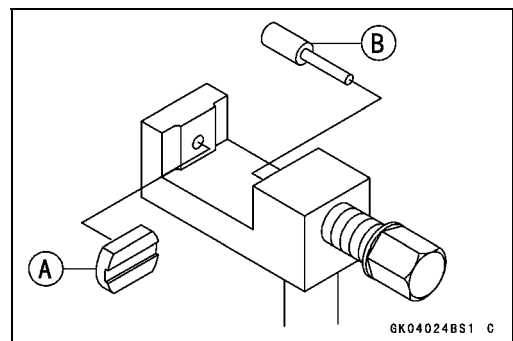

- Turn the pin holder until riveting pin touches link pin.

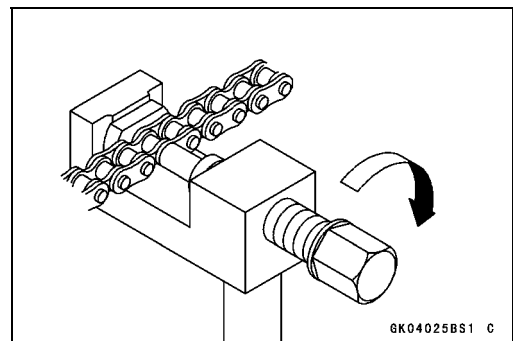

- Turn the wrench clockwise until tip of riveting pin hits of link pin.
- Rivet it.
- Same work for the other link pin.

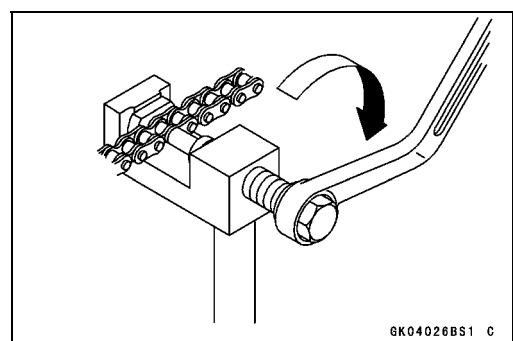

## Drive Chain

- After staking, check the staked area of the link pin for cracks.
- Measure the outside diameter [A] of the link pin and link plates width [B].

### Link Pin Outside Diameter

Standard: 5.7 ~ 6.0 mm (0.22 ~ 0.24 in.)

### Link Plates Outside Width

Standard: 17.25 ~ 17.45 mm (0.679 ~ 0.687 in.)

- ★ If the reading exceeds the specified length, cut and rejoin the chain again.
- Check:
  - Movement of the Rollers
- Adjust the drive chain slack after installing the chain (see Drive Chain Slack Adjustment in the Periodic Maintenance chapter).

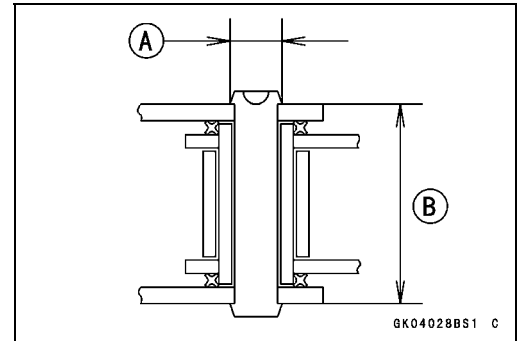

## 11-10 FINAL DRIVE

### Sprocket, Coupling

#### Engine Sprocket Removal

- Remove:
  - Engine Sprocket Cover Bolts [A]
  - Engine Sprocket Cover [B]

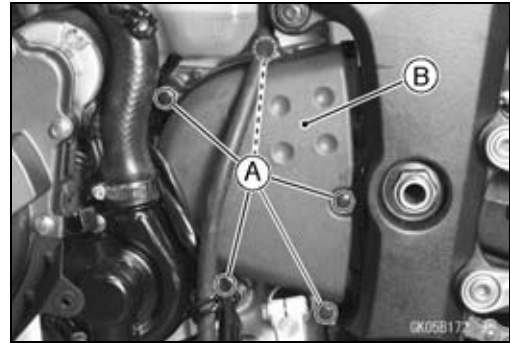

- Flatten out the bended washer [A].
- Remove the engine sprocket nut [B] and washer.

#### NOTE

○When loosening the engine sprocket nut, hold the rear brake on.

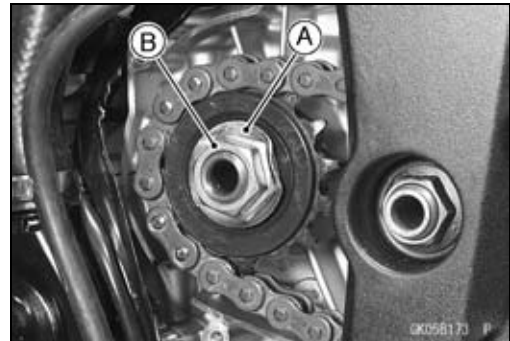

- Raise the rear wheel off the ground.
- Remove the axle cotter pin, and loosen the rear axle nut.
- Loosen the both chain adjuster locknut to loosen the drive chain.
- Remove the drive chain from the rear sprocket toward the right.
- Pull the engine sprocket [A] with drive chain [B] off the output shaft [C].
- Disengage the drive chain from the engine sprocket.

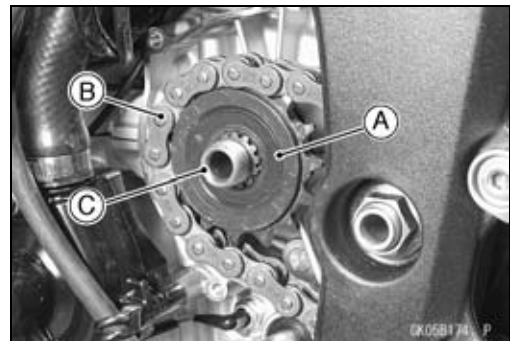

#### Engine Sprocket Installation

- Replace the sprocket washer and axle cotter pin.
- Install the engine sprocket onto the shaft so that the mark side [A] faces outwards.
- Apply molybdenum disulfide oil solution to the threads of the output shaft and the seating surface of the engine sprocket nut.
- After torquing the engine sprocket nut, bend the one side of the washer [B] over the nut.

#### NOTE

○Tighten the nut while applying the rear brake.

**Torque - Engine Sprocket Nut: 125 N·m (13 kgf·m, 92 ft·lb)**

- Adjust the drive chain slack after installing the sprocket (see Drive Chain Slack Adjustment in the Periodic Maintenance chapter).

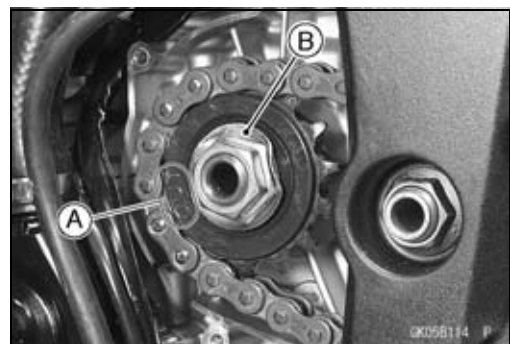

## Sprocket, Coupling

- Install the engine sprocket cover.
- Install the stay [A] and clamp [B] as shown, and tighten the cover bolts.

**Torque - Engine Sprocket Cover Bolts: 6.9 N·m (0.70 kgf·m, 61 in·lb)**

- Bend the end of axle cotter pin surely after tightening the axle nut.

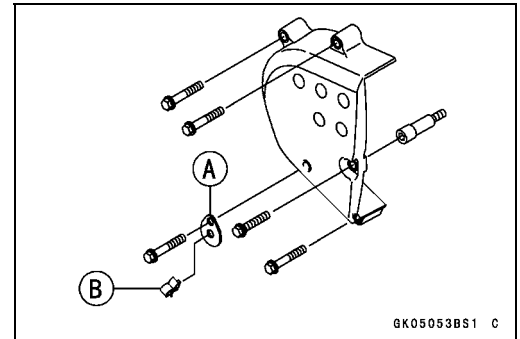

### Rear Sprocket Removal

- Remove the rear wheel (see Rear Wheel Removal in the Wheels/Tires chapter).

#### CAUTION

**Do not lay the wheel on the ground with the disc facing down. This can damage or warp the disc. Place blocks under the wheel so that the disc does not touch the ground.**

- Remove the rear sprocket nuts [A].
- Remove the rear sprocket [B].



### Rear Sprocket Installation

- Install the sprocket facing the tooth number marking [A] outward.
- Tighten the rear sprocket nuts.

**Torque - Rear Sprocket Nuts: 59 N·m (6.0 kgf·m, 43 ft·lb)**

- Install the rear wheel (see Rear Wheel Installation in the Wheels/Tires chapter).



### Coupling Installation

- Grease the following and install the coupling.
  - Coupling Grease Seal Lips [A]
  - Coupling Internal Surface [B]

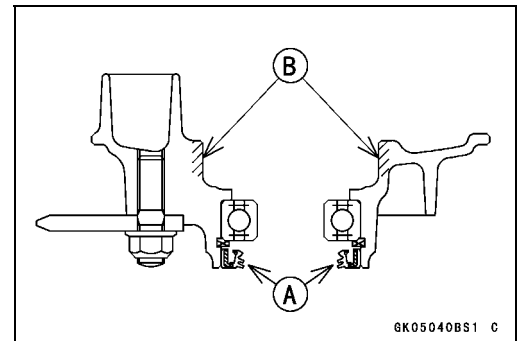

## 11-12 FINAL DRIVE

### Sprocket, Coupling

- Apply grease to the O-ring [A].
- Install the collar [B]

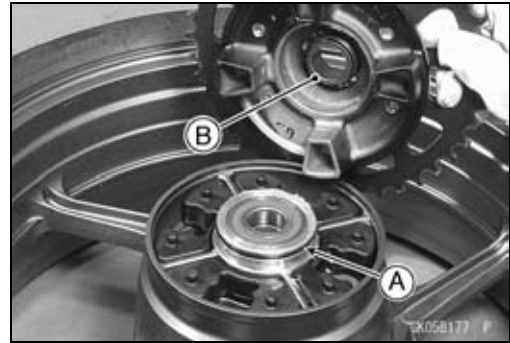

#### Coupling Bearing Removal

- Remove:
  - Coupling
  - Grease Seal
  - Circlip [A]

**Special Tool - Inside Circlip Pliers [B]: 57001-143**

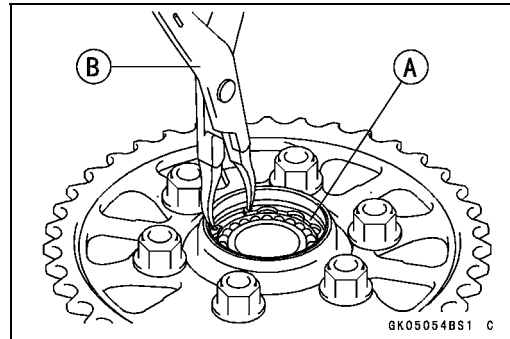

- Remove the bearing [A] by tapping from the wheel side.

**Special Tool - Bearing Driver Set [B]: 57001-1129**

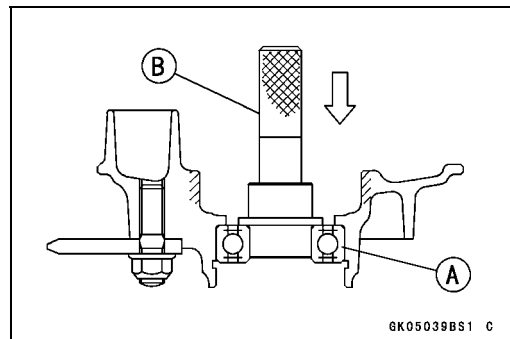

#### Coupling Bearing Installation

- Replace the bearing with a new one.

#### NOTE

○ Install the bearing so that the marked side faces out.

- Press in the bearing [A] until it is bottomed.  
**Special Tool - Bearing Driver Set [B]: 57001-1129**
- Replace the circlip with a new one.  
**Special Tool - Inside Circlip Pliers: 57001-143**

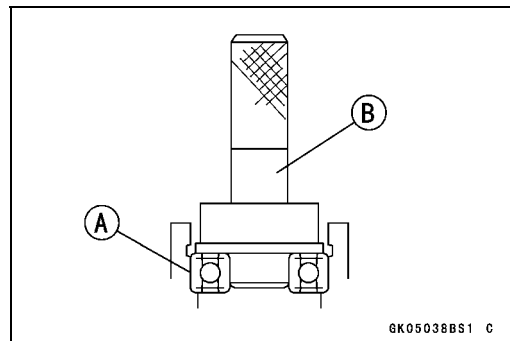

- Replace the grease seal with a new one.
- Press in the grease seal so that the seal surface is flush with the end of the hole.
- Apply high-temperature grease to the grease seal lips.  
**Special Tool - Bearing Driver Set: 57001-1129**

## Sprocket, Coupling

### Coupling Bearing Inspection

Since the coupling bearing is made to extremely close tolerances, the clearance can not normally be measured.

#### NOTE

○It is not necessary to remove the coupling bearing for inspection. If the bearing is removed, it will need to be replaced with a new one.

- Turn the bearing in the coupling back and forth [A] while checking for plays, roughness, or binding.
- ★ If bearing play, roughness, or binding is found, replace the bearing.
- Examine the bearing seal [B] for tears or leakage.
- ★ If the seal is torn or is leaking, replace the bearing.

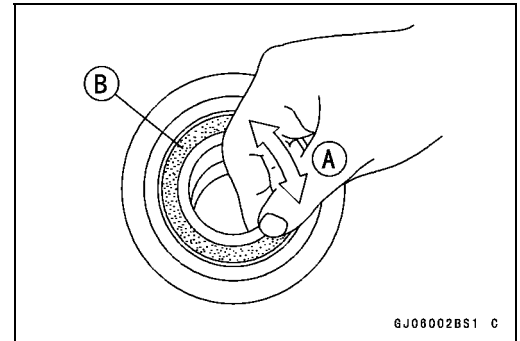

### Coupling Bearing Lubrication

#### NOTE

○Since the coupling bearing is packed with grease and sealed, lubrication is not required.

### Coupling Damper Inspection

- Remove the rear wheel coupling, and inspect the rubber dampers [A].
- Replace the damper if it appears damaged or deteriorated.

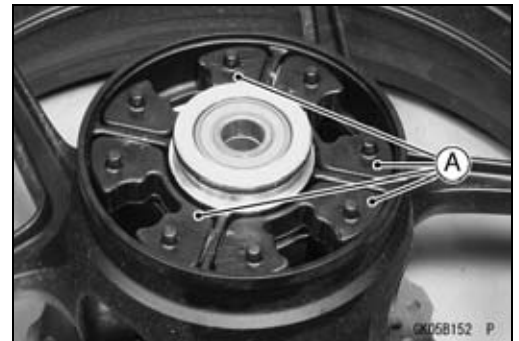

### Sprocket Wear Inspection

- Visually inspect the engine and rear sprocket teeth for wear and damage.
- ★ If the teeth are worn as illustrated, replace the sprocket, and inspect the drive chain wear (see Drive Chain Wear Inspection in the Periodic Maintenance chapter).
  - Worn Tooth (Engine Sprocket) [A]
  - Worn Tooth (Rear Sprocket) [B]
  - Direction of Rotation [C]

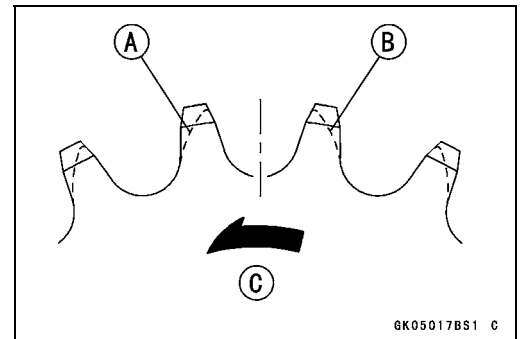

#### NOTE

○If a sprocket requires replacement, the chain is probably worn also.  
When replacing a sprocket, inspect the chain.

## 11-14 FINAL DRIVE

### Sprocket, Coupling

#### *Rear Sprocket Warp Inspection*

- Raise the rear wheel off the ground so that it will turn freely.
- Set a dial gauge [A] against the rear sprocket [B] near the teeth as shown, and rotate [C] the rear wheel to measure the sprocket runout (warp). The difference between the highest and lowest dial gauge readings is the amount of runout (warp).
- ★ If the runout exceeds the service limit, replace the rear sprocket.

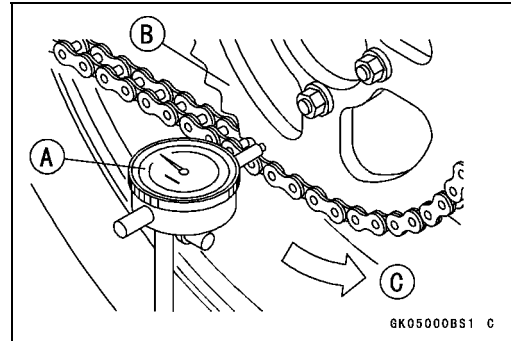

#### **Rear Sprocket Warp**

**Standard:** 0.4 mm (0.016 in.) or less

**Service Limit:** 0.5 mm (0.02 in.)

# Brakes

## Table of Contents

Exploded View .....	12-2	Rear Brake Pad Installation .....	12-14
Specifications .....	12-6	Brake Pad Wear Inspection .....	12-14
Special Tools .....	12-7	Master Cylinder .....	12-15
Brake Lever, Brake Pedal.....	12-8	Front Master Cylinder Removal ...	12-15
Brake Lever Position Adjustment.	12-8	Front Master Cylinder Installation	12-15
Brake Pedal Position Inspection .	12-8	Rear Master Cylinder Removal....	12-16
Brake Pedal Position Adjustment	12-8	Rear Master Cylinder Installation.	12-16
Brake Pedal Removal .....	12-8	Front Master Cylinder	
Brake Pedal Installation .....	12-9	Disassembly.....	12-16
Calipers .....	12-10	Rear Master Cylinder	
Front Caliper Removal .....	12-10	Disassembly.....	12-16
Rear Caliper Removal.....	12-10	Master Cylinder Assembly .....	12-16
Caliper Installation .....	12-10	Master Cylinder Inspection (Visual	
Front Caliper Disassembly.....	12-11	Inspection).....	12-16
Front Caliper Assembly.....	12-11	Brake Disc .....	12-18
Rear Caliper Disassembly .....	12-11	Brake Disc Removal .....	12-18
Rear Caliper Assembly .....	12-11	Brake Disc Installation .....	12-18
Caliper Fluid Seal Damage .....	12-11	Brake Disc Wear .....	12-18
Rear Caliper Dust Boot and		Brake Disc Warp .....	12-18
Friction Boot Damage .....	12-12	Brake Fluid .....	12-19
Caliper Piston and Cylinder		Brake Fluid Level Inspection.....	12-19
Damage.....	12-12	Brake Fluid Change .....	12-19
Rear Caliper Holder Shaft Wear ..	12-12	Brake Line Bleeding.....	12-19
Brake Pads.....	12-13	Brake Hose.....	12-23
Front Brake Pad Removal.....	12-13	Brake Hose Removal/Installation.	12-23
Front Brake Pad Installation.....	12-13	Brake Hose Inspection.....	12-23
Rear Brake Pad Removal .....	12-14		

# 12-2 BRAKES

## Exploded View

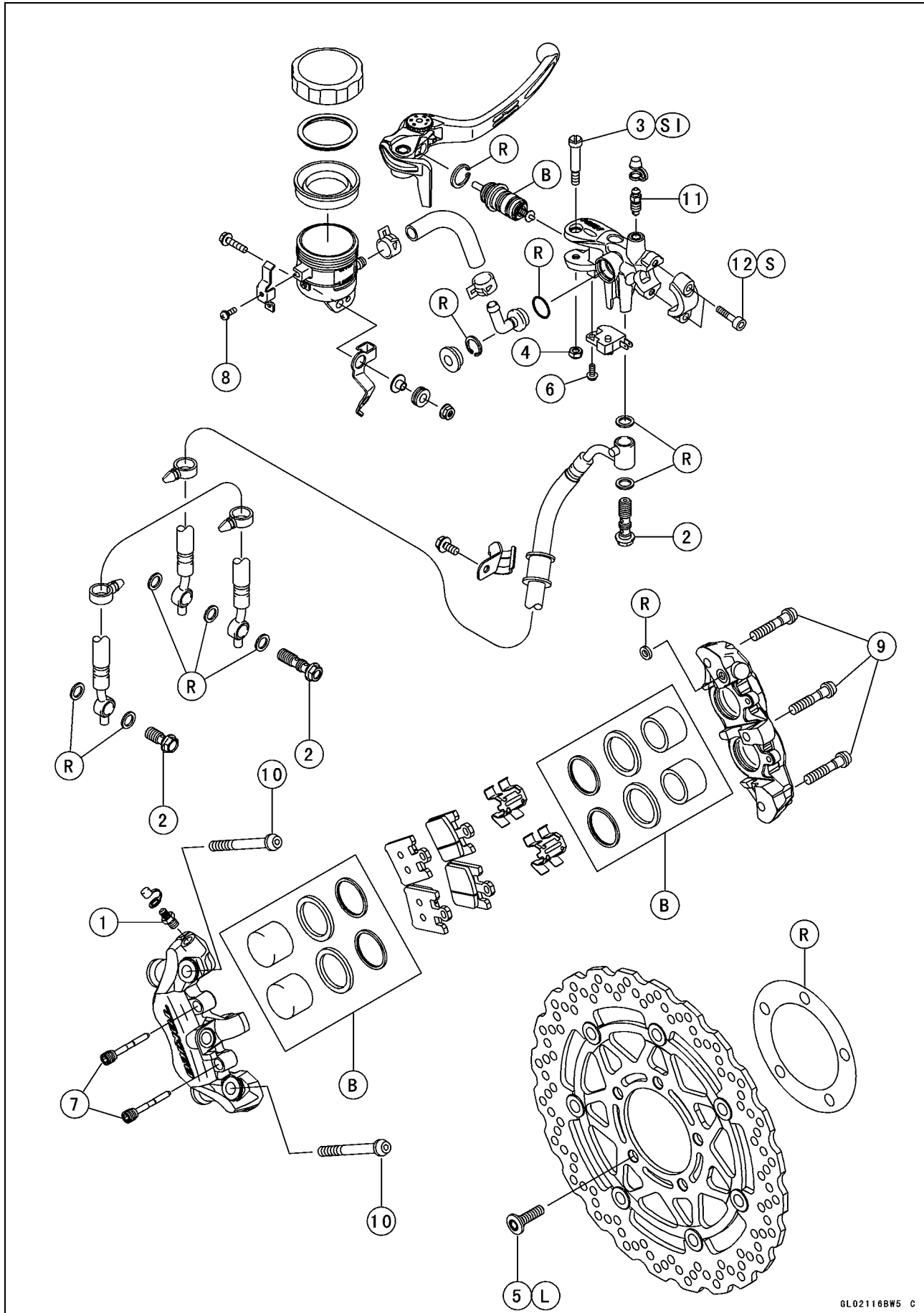

## Exploded View

No.	Fastener	Torque			Remarks
		N·m	kgf·m	ft·lb	
1	Bleed Valves	7.8	0.80	69 in·lb	
2	Brake Hose Banjo Bolts	34	3.5	25	
3	Brake Lever Pivot Bolt	1.0	0.10	9 in·lb	SI
4	Brake Lever Pivot Bolt Locknut	5.9	0.60	52 in·lb	
5	Front Brake Disc Mounting Bolts	27	2.8	20	L
6	Front Brake Light Switch Screw	1.2	0.12	10 in·lb	
7	Front Brake Pad Pins	15	1.5	11	
8	Front Brake Reservoir Cap Stopper Screw	1.2	0.12	10 in·lb	
9	Front Caliper Assembly Bolts	22	2.2	16	
10	Front Caliper Mounting Bolts	34	3.5	25	
11	Front Master Cylinder Bleed Valve	5.9	0.60	52 in·lb	
12	Front Master Cylinder Clamp Bolts	8.8	0.90	78 in·lb	S

B: Apply brake fluid.

L: Apply a non-permanent locking agent.

R: Replacement Parts

S: Follow the specific tightening sequence.

SI: Apply silicone grease.

# 12-4 BRAKES

## Exploded View

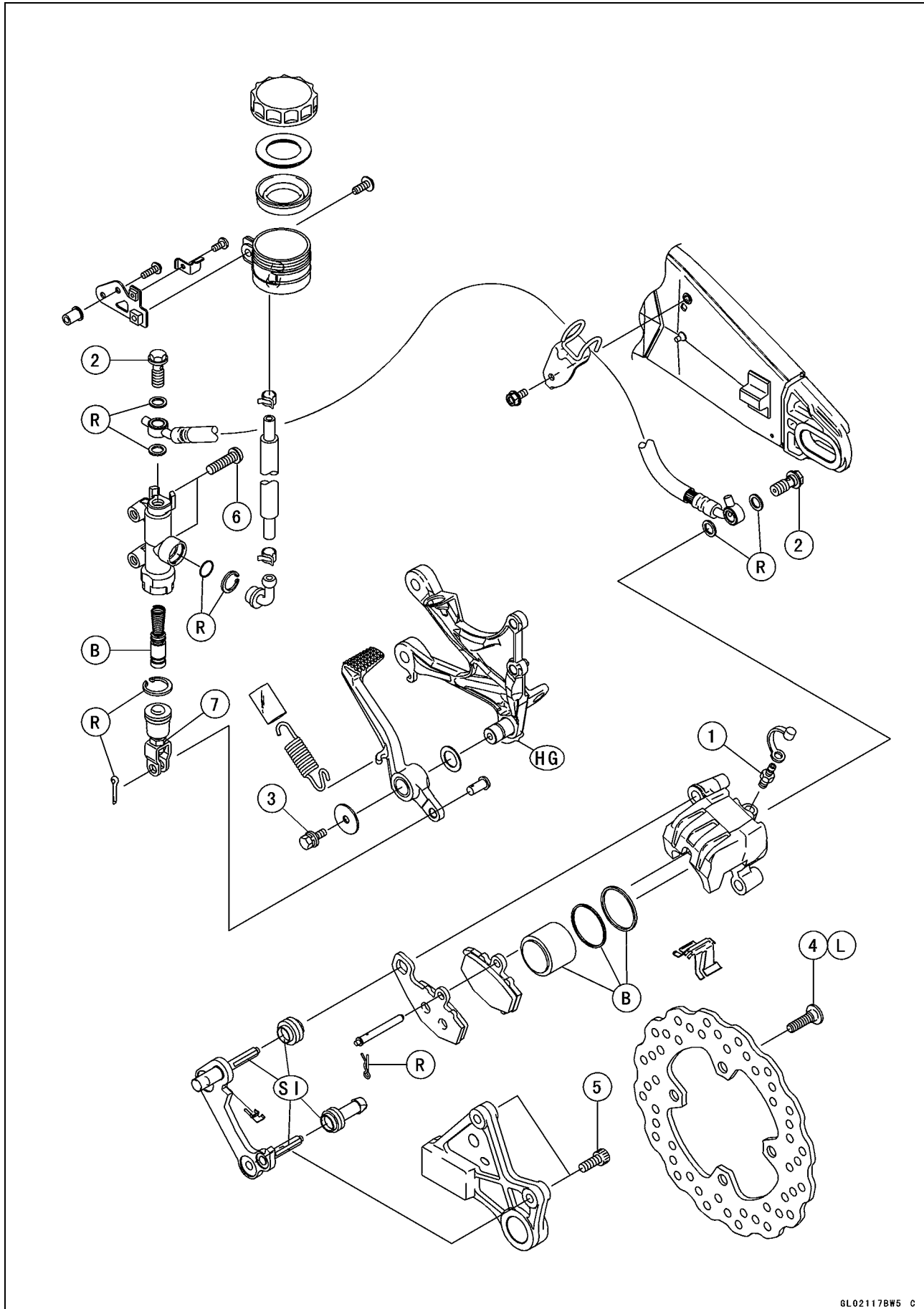

## Exploded View

No.	Fastener	Torque			Remarks
		N·m	kgf·m	ft·lb	
1	Bleed Valve	7.8	0.80	69 in·lb	
2	Brake Hose Banjo Bolts	34	3.5	25	
3	Brake Pedal Bolt	8.8	0.90	78 in·lb	
4	Rear Brake Disc Mounting Bolts	27	2.8	20	L
5	Rear Caliper Mounting Bolts	25	2.5	18	
6	Rear Master Cylinder Mounting Bolts	25	2.5	18	
7	Rear Master Cylinder Push Rod Locknut	18	1.8	13	

B: Apply brake fluid.

HG: Apply high-temperature grease.

L: Apply a non-permanent locking agent.

R: Replacement Parts

SI: Apply silicone grease.

## 12-6 BRAKES

### Specifications

Item	Standard	Service Limit
<b>Brake Lever, Brake Pedal</b>		
Brake Lever Position	6-way adjustable (to suit rider)	---
Brake Lever Free Play	Non-adjustable	---
Pedal Free Play	Non-adjustable	---
Pedal Position	About 60 mm (2.4 in.) below footpeg top	---
<b>Brake Discs</b>		
Thickness:		
Front	5.3 ~ 5.7 mm (0.21 ~ 0.22 in.)	5.0 mm (0.20 in.)
Rear	4.8 ~ 5.2 mm (0.19 ~ 0.20 in.)	4.5 mm (0.18 in.)
Runout	0.15 mm (0.006 in.) or less	0.3 mm (0.01 in.)

**Special Tools**

**Inside Circlip Pliers:**  
**57001-143**

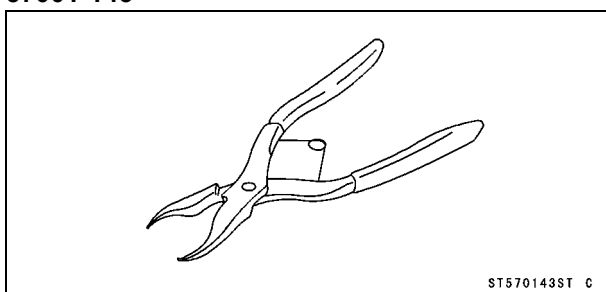

**Jack Attachment:**  
**57001-1608**

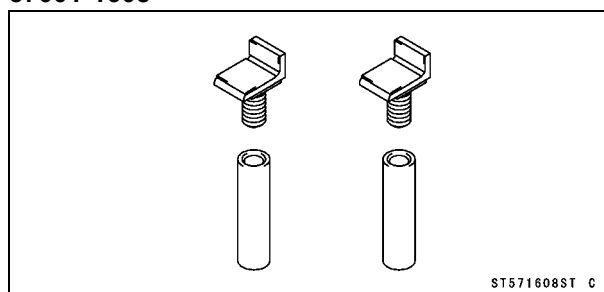

**Jack:**  
**57001-1238**

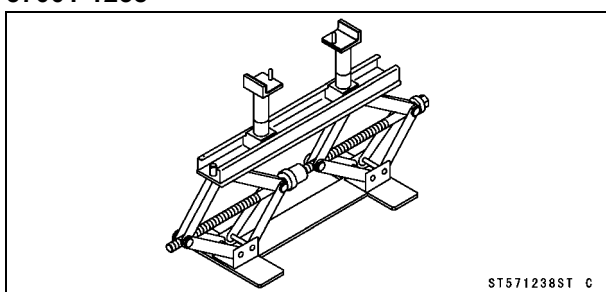

## 12-8 BRAKES

### Brake Lever, Brake Pedal

#### Brake Lever Position Adjustment

The brake lever adjuster has 6 positions so that the brake lever position can be adjusted to suit the operator's hand.

- Push the lever forward and turn the adjuster [A] to align the number with the arrow mark [B] on the lever holder.
- The distance from the grip to the lever is minimum at number 6 and maximum at number 1.

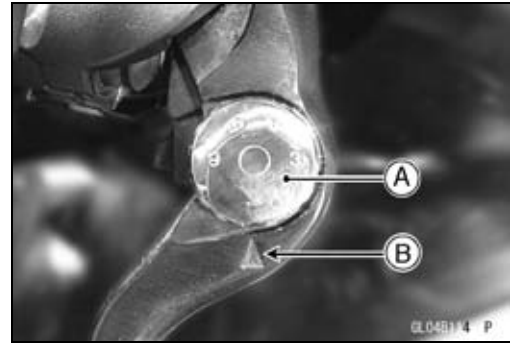

#### Brake Pedal Position Inspection

- Check that the brake pedal [A] is in the correct position. Footpeg [B]

##### Pedal Position

**Standard:** About 60 mm (2.4 in.) [C] below top of footpeg

- ★ If it is incorrect, adjust the brake pedal position.

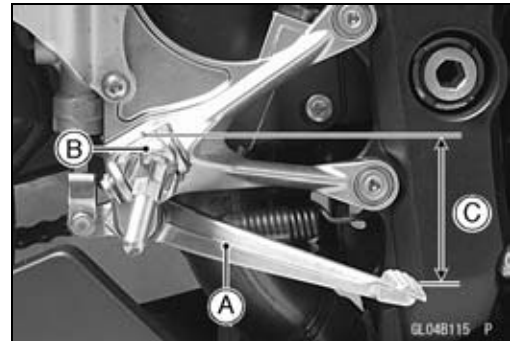

#### Brake Pedal Position Adjustment

##### NOTE

○ Usually it is not necessary to adjust the pedal position, but always adjust it when push rod locknut has been loosened.

- Loosen the locknut [A] and turn the push rod with the hex head [B] to achieve the correct pedal position.
- ★ If the length [C] shown is  $70 \pm 1$  mm ( $2.8 \pm 0.04$  in.), the pedal position will be within the standard range.
- Tighten:

**Torque - Rear Master Cylinder Push Rod Locknut: 18 N·m (1.8 kgf·m, 13 ft·lb)**

- Check the brake light switch operation (see Brake Light Switch Operation Inspection in the Periodic Maintenance chapter).

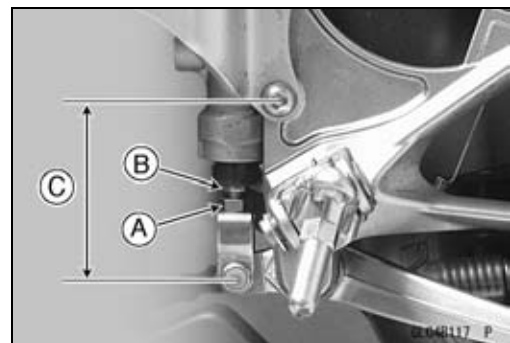

#### Brake Pedal Removal

- Remove:
  - Rear Master Cylinder Mounting Bolts [A]
  - Right Footpeg Bracket Bolts [B]



## Brake Lever, Brake Pedal

- Remove:
  - Cotter Pin [A]
  - Joint Pin [B]
  - Rear Brake Light Switch Spring [C]
  - Return Spring [D]
- Remove the mounting bolt [E] and take out the brake pedal.

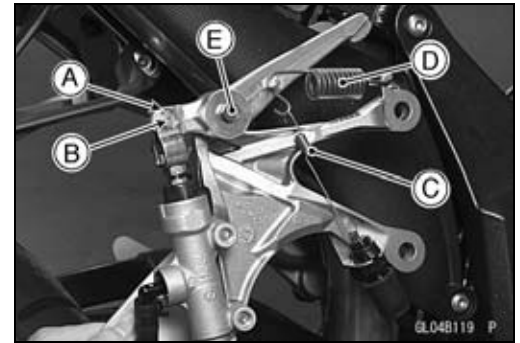

### Brake Pedal Installation

- Apply high-temperature grease to the pivot shaft [A] and install the washer [B].
- Install:
  - Brake Pedal [C]
  - Washer [D]
  - Brake Pedal Bolt [E]

**Torque - Brake Pedal Bolt: 8.8 N·m (0.90 kgf·m, 78 in·lb)**

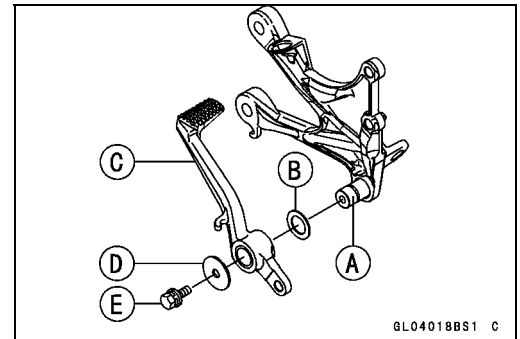

- Hook the lower end of the rear brake light switch spring [A] on the pedal hook.
- Hook the upper end of the return spring [B] on the pedal hook.

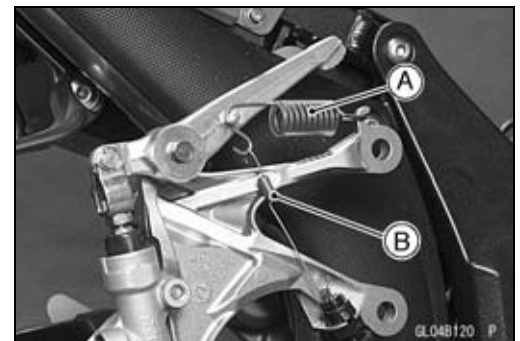

- Replace the cotter pin with a new one.
- Insert the cotter pin [A] and bend the pin ends [B].

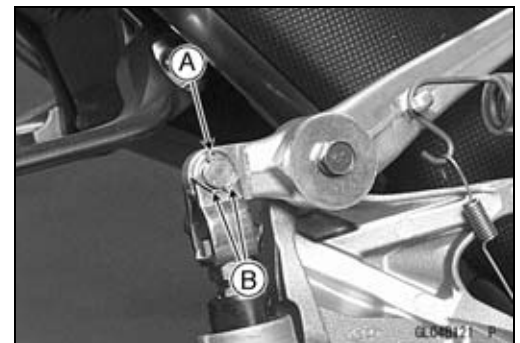

- Install the right footpeg bracket.
  - Torque - Front Footpeg Bracket Bolts: 25 N·m (2.5 kgf·m, 18 ft·lb)**
- Depress the brake pedal [A] and then align the bolts holes of the master cylinder [B].
  - Torque - Rear Master Cylinder Mounting Bolts: 25 N·m (2.5 kgf·m, 18 ft·lb)**
- Check the brake pedal position (see Brake Pedal Position Inspection in this chapter).

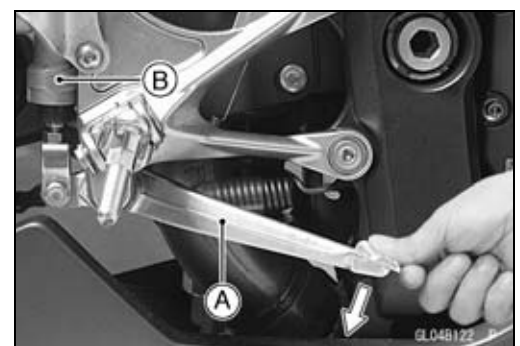

## 12-10 BRAKES

### Calipers

#### Front Caliper Removal

- Loosen the banjo bolt [A] at the brake hose lower end, and tighten it loosely.
- Unscrew the caliper mounting bolts [B], and detach the caliper [C] from the disc.

#### CAUTION

**Do not loosen the caliper assembly bolts [D]. Take out only the caliper mounting bolts for caliper removal. Loosening the caliper assembly bolts will cause brake fluid leakage.**

- Unscrew the banjo bolt and remove the brake hose [E] from the caliper (see Brake Hose Removal/Installation in this chapter).

#### CAUTION

**Immediately wash away any brake fluid that spills.**

#### NOTE

○If the caliper is to be disassembled after removal and if compressed air is not available, disassemble the caliper before the brake hose is removed (see Front Caliper Disassembly in this chapter).

#### Rear Caliper Removal

- Loosen the banjo bolt [A] at the brake hose lower end, and tighten it loosely.
- Unscrew the caliper mounting bolts [B], and detach the caliper [C] from the disc.
- Unscrew the banjo bolt and remove the brake hose [D] from the caliper.

#### CAUTION

**Immediately wash away any brake fluid that spills.**

#### NOTE

○If the caliper is to be disassembled after removal and if compressed air is not available, disassemble the caliper before the brake hose is removed (see Rear Caliper Disassembly in this chapter).

#### Caliper Installation

- Install the caliper and brake hose lower end.
- Replace the washers on each side of hose fitting with new ones.
- Tighten:

##### Torque - Caliper Mounting Bolts

Front: 34 N·m (3.5 kgf·m, 25 ft·lb)

Rear: 25 N·m (2.5 kgf·m, 18 ft·lb)

Brake Hose Banjo Bolts: 34 N·m (3.5 kgf·m, 25 ft·lb)

- Check the fluid level in the brake reservoirs.
- Bleed the brake line (see Brake Line Bleeding in this chapter).
- Check the brake for good braking power, no brake drag, and no fluid leakage.

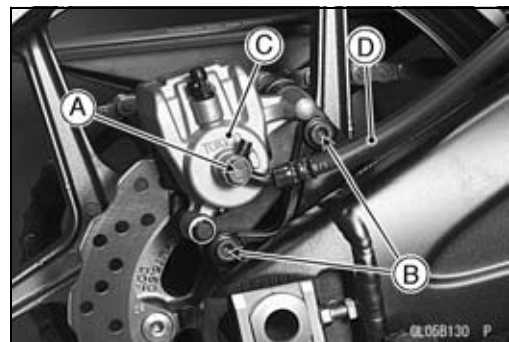
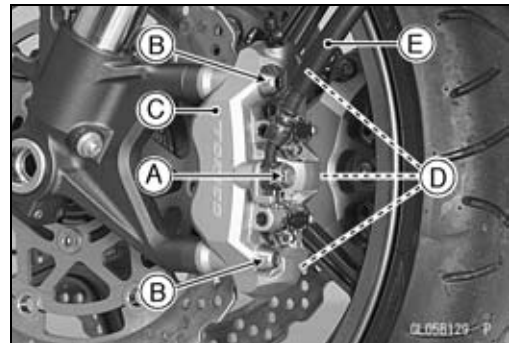

## Calipers

### **⚠ WARNING**

**Do not attempt to drive the motorcycle until a full brake lever or pedal is obtained by pumping the brake lever or pedal until the pads are against the disc. The brakes will not function on the first application of the lever or pedal if this is not done.**

#### *Front Caliper Disassembly*

- Refer to the Caliper Rubber Parts Replacement in the Periodic Maintenance chapter.

#### *Front Caliper Assembly*

- Refer to the Caliper Rubber Parts Replacement in the Periodic Maintenance chapter.

#### *Rear Caliper Disassembly*

- Refer to the Caliper Rubber Parts Replacement in the Periodic Maintenance chapter.

#### *Rear Caliper Assembly*

- Refer to the Caliper Rubber Parts Replacement in the Periodic Maintenance chapter.

#### *Caliper Fluid Seal Damage*

The fluid seal (piston seal) [A] is placed around the piston to maintain clearance between the pad and the disc. If the seal is in a poor condition, it could lead the pad to wear excessively or the brake to drag, which may cause the temperature of the discs or the brake fluid to increase.

- Replace the fluid seal if it exhibits any of the conditions listed below.
  - Brake fluid leakage around the pad.
  - Brakes overheat.
  - Considerable difference in inner and outer pad wear.
  - Seal and piston are stuck together.
- ★ If the fluid seal is replaced, replace the dust seal [B] as well. Also, replace all seals every other time the pads are changed.

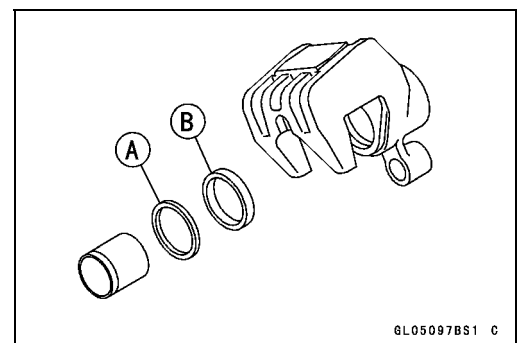
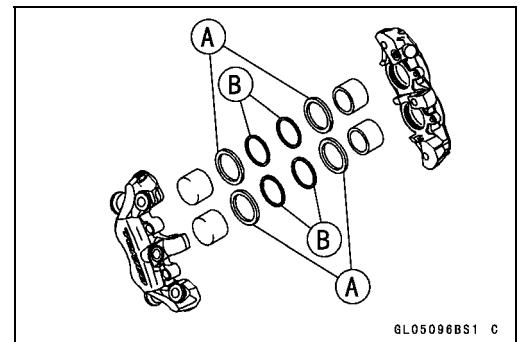

## 12-12 BRAKES

### Calipers

#### Rear Caliper Dust Boot and Friction Boot Damage

- Check that the dust boot [A] and friction boot [B] are not cracked, worn, swollen, or otherwise damaged.
- ★ If they show any damage, replace it.

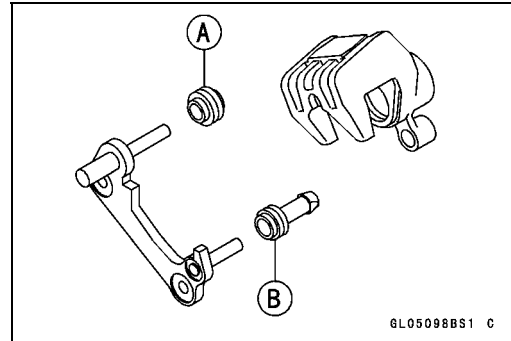

#### Caliper Piston and Cylinder Damage

- Visually inspect the pistons [A] and cylinder surfaces [B].
- ★ Replace the caliper if the cylinder and piston are badly scored or rusty.

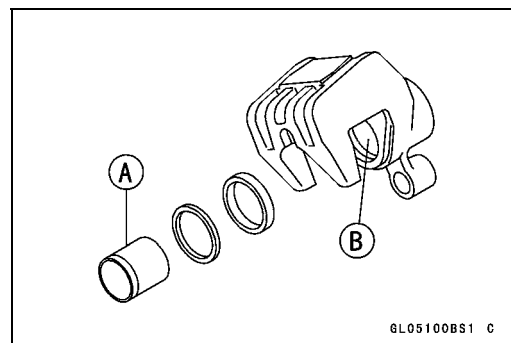
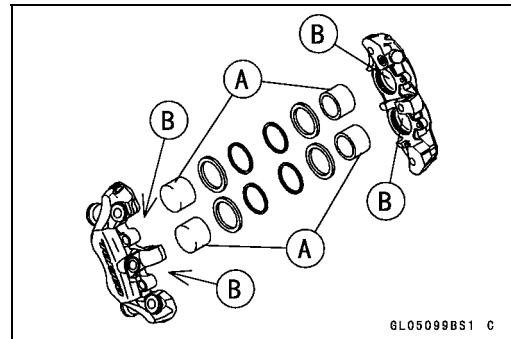

#### Rear Caliper Holder Shaft Wear

The caliper body must slide smoothly on the caliper holder shafts [A]. If the body does not slide smoothly, one pad will wear more than the other, pad wear will increase, and constant drag on the disc will raise brake and brake fluid temperature.

- Check to see that the caliper holder shafts are not badly worn or stepped, and that the rubber friction boots are not damaged.
- ★ If the rubber friction boot is damaged, replace the rubber friction boot. To replace the friction boot, remove the pads and the caliper bracket.
- ★ If the caliper holder shaft is damaged, replace the caliper bracket.

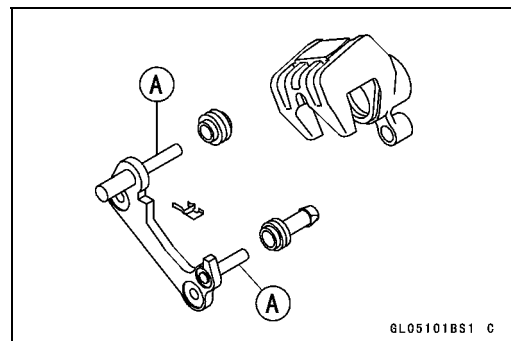

## Brake Pads

### Front Brake Pad Removal

- Loosen:  
Pad Pins [A]

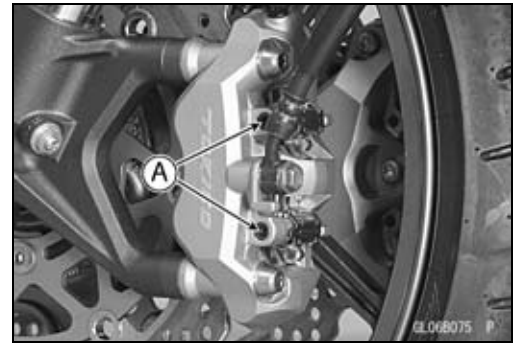

- Remove:  
Pad Pins [A]  
Pad Springs [B]  
Brake Pads [C]

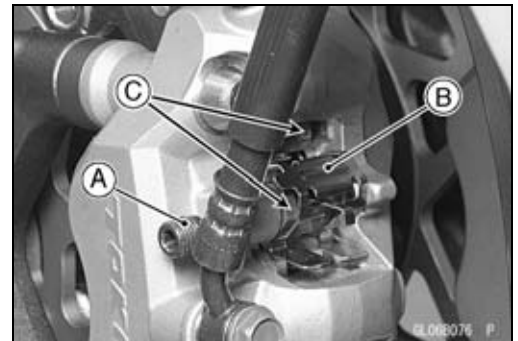

### Front Brake Pad Installation

- Push the caliper pistons in by hand as far as they will go.
- Install the outside pad [A] and insert the pad pin [B] as shown.

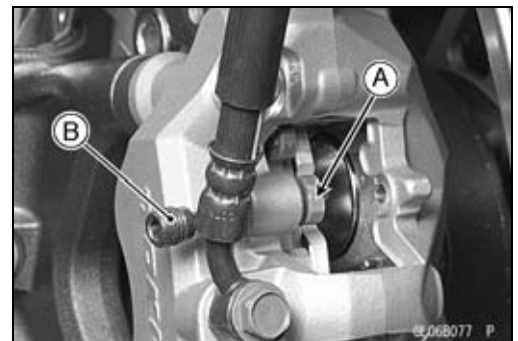

- Set:  
Inside Pad [A]  
Pad Spring [B]
- Pushing the pin holder [C] to hole of the pad and insert the pad pin.

**Torque - Front Brake Pad Pins: 15 N·m (1.5 kgf·m, 11 ft·lb)**

### **⚠ WARNING**

**Do not attempt to drive the motorcycle until a full brake lever is obtained by pumping the brake lever and the pads are against the disc. The brake will not function on the first application of the lever if this is not done.**

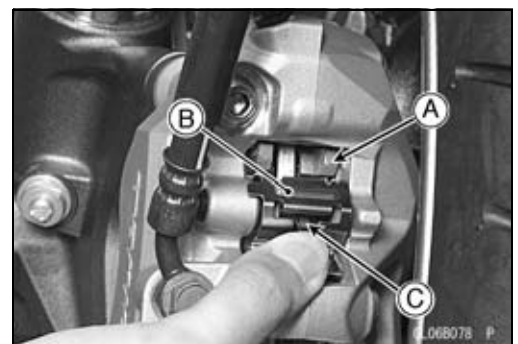

## 12-14 BRAKES

### Brake Pads

#### *Rear Brake Pad Removal*

- Remove the caliper with the hose installed.
- Remove:
  - Clip [A]
  - Pad Pin [B]
  - Brake Pads [C]

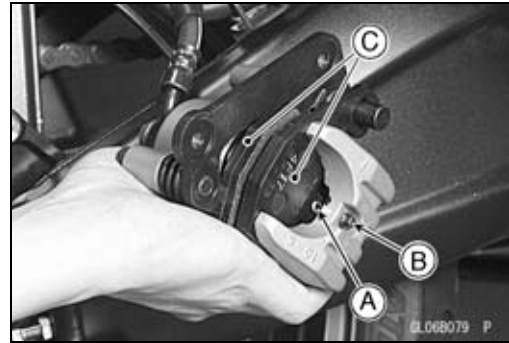

#### *Rear Brake Pad Installation*

- Push the caliper piston in by hand as far as it will go.
- Install the pad spring in place.
- Install the piston side pad [A] first, and then another pad.
- Fit the projections [B] of the pad into the recess [C] of the caliper holder.
- Install the pad pin and clip. The clip must be “outside” of the pads.
- Install the caliper (see Caliper Installation in this chapter).

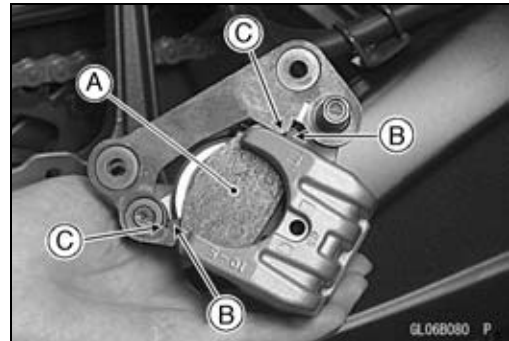

#### **⚠ WARNING**

**Do not attempt to drive the motorcycle until a full brake pedal is obtained by pumping the brake pedal until the pads are against the disc. The brake will not function on the first application of the pedal if this is not done.**

#### *Brake Pad Wear Inspection*

- Refer to the Brake Pad Wear Inspection in the Periodic Maintenance chapter.

## Master Cylinder

### Front Master Cylinder Removal

- Remove the reservoir bracket nut [A].



- Remove the banjo bolt [A] to disconnect the brake hose from the master cylinder (see Brake Hose Removal/Installation in this chapter).
- Unscrew the clamp bolts [B], and take off the master cylinder [C] as an assembly with the reservoir, brake lever, and brake switch installed.
- Disconnect the front brake light switch connector [D].

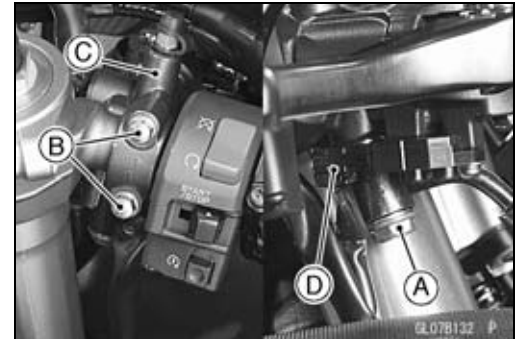

### CAUTION

**Immediately wash away any brake fluid that spills.**

- Remove:
  - Brake Lever Pivot Bolt [A] and Nut
  - Brake Lever [B]
  - Clamp [C] (Slide Out)
  - Brake Hose [D]
  - Front Brake Light Switch [E]

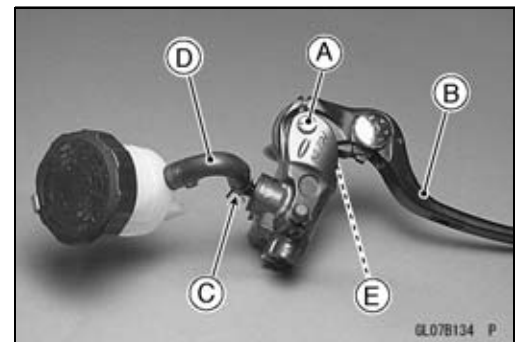

### Front Master Cylinder Installation

- Set the front master cylinder to match its mating surface [A] to the punch mark [B] of the handlebar.
- The master cylinder clamp must be installed with the arrow mark [C] upward.
- Tighten the upper clamp bolt first, and then the lower clamp bolt.

**Torque - Front Master Cylinder Clamp Bolts: 8.8 N·m (0.90 kgf·m, 78 in·lb)**

- Replace the washers that are on each side of the hose fitting with new ones.
- Tighten:

**Torque - Brake Hose Banjo Bolt: 34 N·m (3.5 kgf·m, 25 ft·lb)**

- Bleed the brake line (see Brake Line Bleeding in this chapter).
- Check the brake for good braking power, no brake drag, and no fluid leakage.

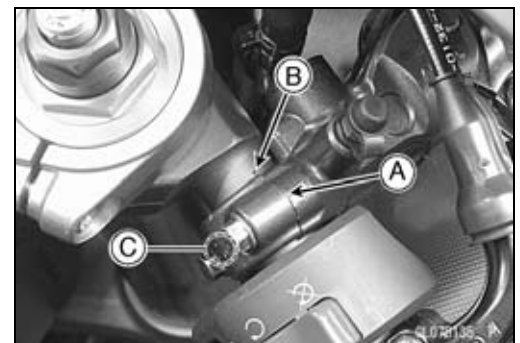

## 12-16 BRAKES

### Master Cylinder

#### Rear Master Cylinder Removal

- Unscrew the brake hose banjo bolt [A] and brake hose [B].
- Remove:
  - Cotter Pin [C]
  - Joint Pin [D]
  - Bolts [E]
  - Foot Guard [F]
  - Rear Master Cylinder
- Slide out the clamp [G].
- Pull off the reservoir hose lower end [H], and drain the brake fluid into a container.

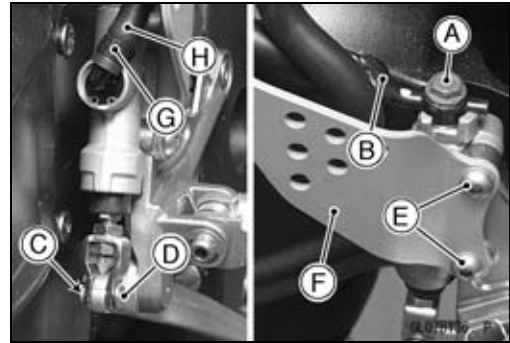

#### Rear Master Cylinder Installation

- Replace the cotter pin with a new one.
- Replace the washers that are on each side of hose fitting with new ones.
- Tighten:
  - **Torque - Rear Master Cylinder Mounting Bolts: 25 N·m (2.5 kgf·m, 18 ft·lb)**
  - **Brake Hose Banjo Bolt: 34 N·m (3.5 kgf·m, 25 ft·lb)**
- Bleed the brake line (see Brake Line Bleeding in this chapter).
- Check the brake for good braking power, no brake drag, and no fluid leakage.

#### Front Master Cylinder Disassembly

- Refer to the Master Cylinder Rubber Parts Replacement in the Periodic Maintenance chapter.

#### Rear Master Cylinder Disassembly

- Refer to the Master Cylinder Rubber Parts Replacement in the Periodic Maintenance chapter.

#### Master Cylinder Assembly

- Refer to the Master Cylinder Rubber Parts Replacement in the Periodic Maintenance chapter.

#### Master Cylinder Inspection (Visual Inspection)

- Remove the master cylinders (see Front/Rear Master Cylinder Removal in this chapter).
  - Disassemble the front and rear master cylinders (see Master Cylinder Rubber Parts Replacement in the Periodic Maintenance chapter).
  - Check that there are no scratches, rust or pitting on the inner wall [A] of each master cylinder and on the outside of each piston [B].
  - ★ If a master cylinder or piston shows any damage, replace them.
  - Inspect the primary cup [C] and secondary cup [D].
  - ★ If a cup is worn, damaged softened (rotted), or swollen, the piston assembly should be replaced to renew the cups.
  - ★ If fluid leakage is noted at the brake lever, the piston assembly should be replaced to renew the cups.
- Front Master Cylinder [J]

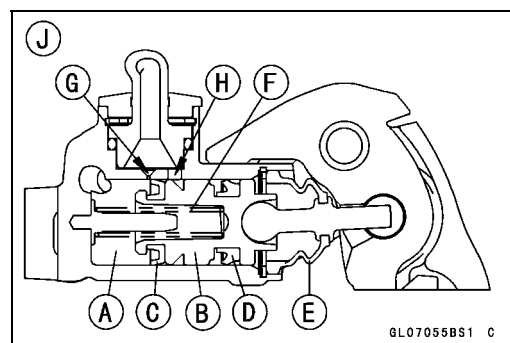

## Master Cylinder

- Check the dust covers [E] for damage.
- ★ If they are damaged, replace them.
- Check the piston return spring [F] for any damage.
- ★ If the springs are damaged, replace them.
- Check that relief port [G] and supply port [H] are not plugged.
- ★ If the relief port becomes plugged, the brake pads will drag on the disc. Blow the ports clean with compressed air.

Rear Master Cylinder [K]

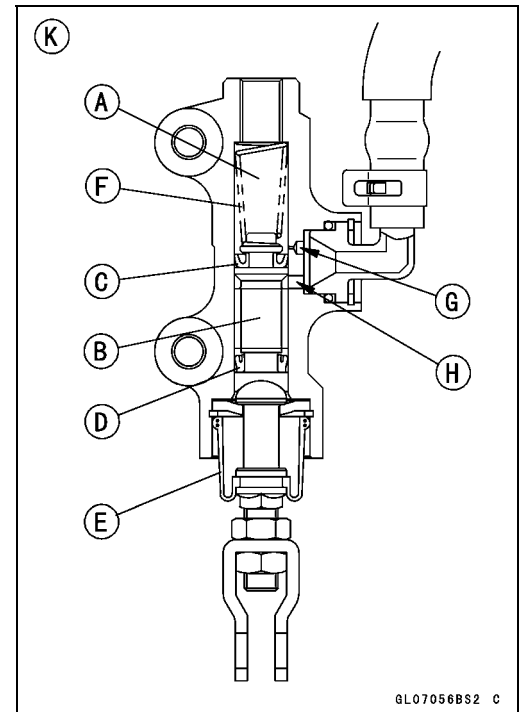

## 12-18 BRAKES

### Brake Disc

#### Brake Disc Removal

- Remove the wheel (see Front/Rear Wheel Removal in the Wheels/Tires chapter).
- Unscrew the mounting bolts, and take off the disc.

#### Brake Disc Installation

- Install the brake disc on the wheel so that the marked side [B] faces out.
- Apply a non-permanent locking agent to the threads of the rear brake disc mounting bolts [A].
- Tighten:

**Torque - Brake Disc Mounting Bolts: 27 N·m (2.8 kgf·m, 20 ft·lb)**

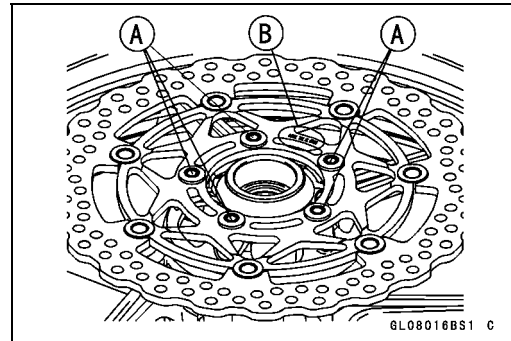

#### Brake Disc Wear

- Measure the thickness of each disc [A] at the point where it has worn the most.
  - ★ If the disc has worn past the service limit, replace it.
- Measuring Area [B]

#### Brake Discs Thickness

##### Standard:

Front	5.3 ~ 5.7 mm (0.21 ~ 0.22 in.)
Rear	4.8 ~ 5.2 mm (0.19 ~ 0.20 in.)

##### Service Limit:

Front	5.0 mm (0.20 in.)
Rear	4.5 mm (0.18 in.)

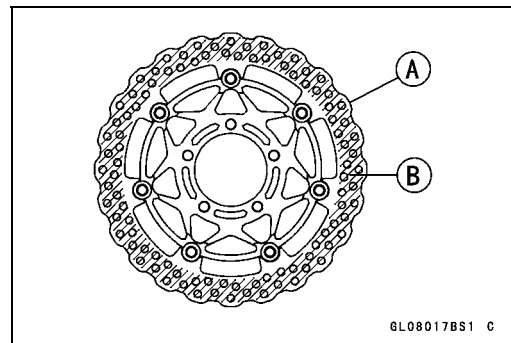

#### Brake Disc Warp

- Jack up the motorcycle so that the wheel is off the ground.

**Special Tools - Jack: 57001-1238**

**Jack Attachment: 57001-1608**

○ For front disc inspection, turn the handlebar fully to one side.

- Set up a dial gauge against the disc [A] as shown and measure disc runout, while turning [B] the wheel by hand.
- ★ If runout exceeds the service limit, replace the disc.

#### Disc Runout

Standard:	0.15 mm (0.006 in.) or less
Service Limit:	0.3 mm (0.01 in.)

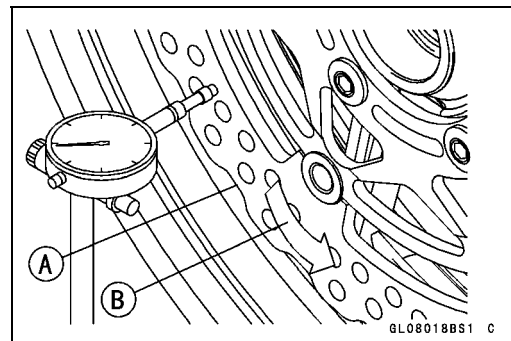

## Brake Fluid

### *Brake Fluid Level Inspection*

- Refer to the Brake Fluid Level Inspection in the Periodic Maintenance chapter.

### *Brake Fluid Change*

- Refer to the Brake Fluid Change in the Periodic Maintenance chapter.

### *Brake Line Bleeding*

The brake fluid has a very low compression coefficient so that almost all the movement of the brake lever or pedal is transmitted directly to the caliper for braking action. Air, however, is easily compressed. When air enters the brake lines, brake lever or pedal movement will be partially used in compressing the air. This will make the lever or pedal feel spongy, and there will be a loss in braking power.

### **⚠ WARNING**

**Be sure to bleed the air from the brake line whenever brake lever or pedal action feels soft or spongy after the brake fluid is changed, or whenever a brake line fitting has been loosened for any reason.**

### **NOTE**

- *The procedure to bleed the front brake line is as follows. Bleeding the rear brake line is the same as for the front brake.*

- Remove:
  - Screw [A]
  - Clamp [B]
  - Front Brake Reservoir Cap [C]
  - Diaphragm Plate
  - Diaphragm
- Fill the reservoir with fresh brake fluid to the upper level line in the reservoir.
- With the reservoir cap off, slowly pump the brake lever several times until no air bubbles can be seen rising up through the fluid from the holes at the bottom of the reservoir.
- Bleed the air completely from the master cylinder by this operation.
- Remove the rubber cap from the bleed valve on the front master cylinder.
- Attach a clear plastic hose [A] to the bleed valve, and run the other end of the hose into a container.

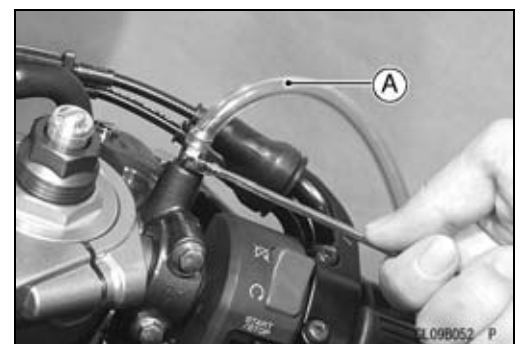
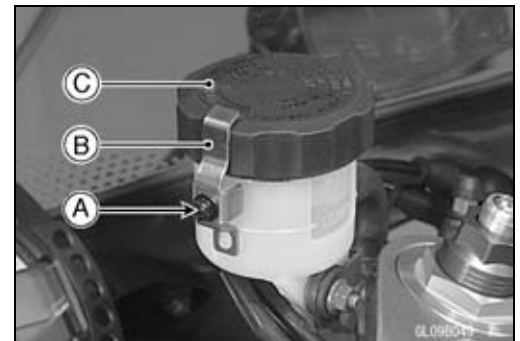

## 12-20 BRAKES

### Brake Fluid

- Bleed the brake line and the master cylinder.
- Repeat this operation until no more air can be seen coming out into the plastic hose.
  1. Pump the brake lever until it becomes hard, and apply the brake and hold it [A].
  2. Quickly open and close [B] the bleed valve while holding the brake applied.
  3. Release the brake [C].

#### NOTE

○ The fluid level must be checked often during the bleeding operation and replenished with fresh brake fluid as necessary. If the fluid in the reservoir runs completely out any time during bleeding, the bleeding operation must be done over again from the beginning since air will have entered the line.

- Remove the clear plastic hose.
- Tighten the bleed valve, and install the rubber cap.

**Torque - Front Master Cylinder Bleed Valve: 5.9 N·m (0.60 kgf·m, 52 in·lb)**

- Remove the rubber cap [A] from the bleed valve on the caliper.
- Attach a clear plastic hose [B] to the bleed valve, and run the other end of the hose into a container.

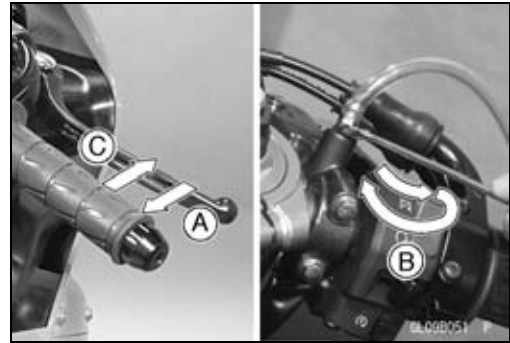

- Bleed the brake line and the caliper.
- Repeat this operation until no more air can be seen coming out into the plastic hose.
  1. Pump the brake lever until it becomes hard, and apply the brake and hold it [A].
  2. Quickly open and close [B] the bleed valve while holding the brake applied.
  3. Release the brake [C].

#### NOTE

○ The fluid level must be checked often during the bleeding operation and replenished with fresh brake fluid as necessary. If the fluid in the reservoir runs completely out any time during bleeding, the bleeding operation must be done over again from the beginning since air will have entered the line.

○ Tap the brake hose lightly from the caliper to the reservoir for more complete bleeding.

○ Front Brake: First bleeding the right caliper then repeat the above steps for the left caliper.

- Remove the clear plastic hose.

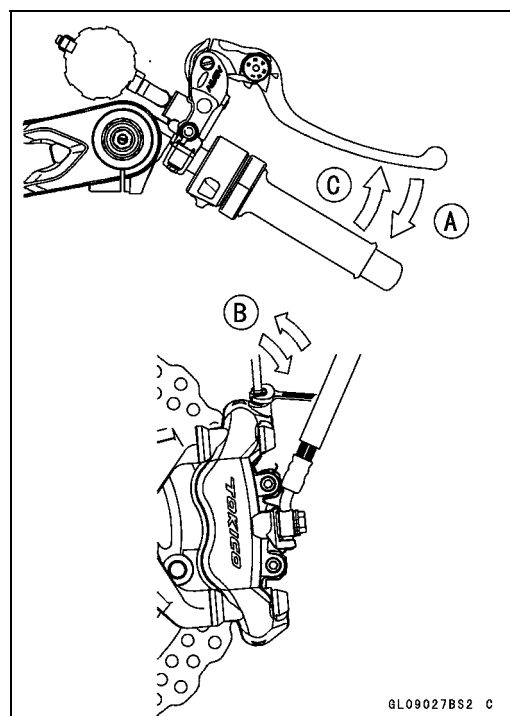
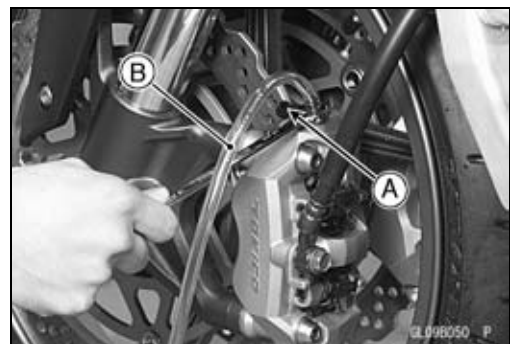

GL09027BS2 C

## Brake Fluid

- Install:
  - Diaphragm [A]
  - Diaphragm Plate [B]
  - Front Brake Reservoir Cap [C]
  - Clamp [D]
  - Screw [E]

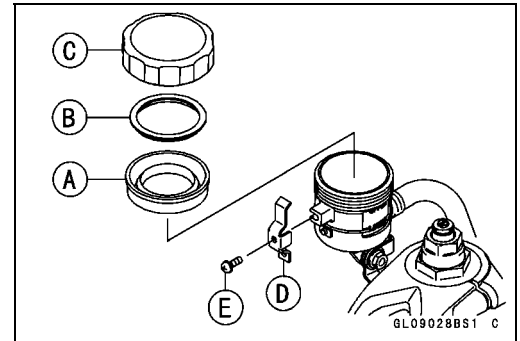

- Follow the procedure below to install the front/rear brake fluid reservoir cap correctly.
  - First, tighten the brake fluid reservoir cap [B] clockwise [C] by hand until the resistance is felt fully; then, tighten the cap an additional 1/6 turn [D] while holding the brake fluid reservoir body [A].

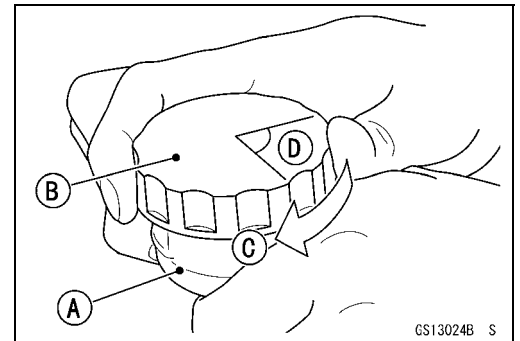

- Tighten the bleed valve, and install the rubber cap.
  - Torque - Bleed Valve: 7.8 N·m (0.80 kgf·m, 69 in·lb)**
- Check the fluid level (see Brake Fluid Level Inspection in the Periodic Maintenance chapter).
- After bleeding is done, check the brake for good braking power, no brake drag, and no fluid leakage.

## 12-22 BRAKES

### Brake Fluid

#### WARNING

**When working with the disc brake, observe the precautions listed below.**

1. Never reuse old brake fluid.
2. Do not use fluid from a container that has been left unsealed or that has been open for a long time.
3. Do not mix two types and brands of fluid for use in the brake. This lowers the brake fluid boiling point and could cause the brake to be ineffective. It may also cause the rubber brake parts to deteriorate.
4. Don't leave the reservoir cap off for any length of time to avoid moisture contamination of the fluid.
5. Don't change the fluid in the rain or when a strong wind is blowing.
6. Except for the disc pads and disc, use only disc brake fluid, isopropyl alcohol, or ethyl alcohol for cleaning of the brake parts. Do not use any other fluid for cleaning these parts. Gasoline, engine oil, or any other petroleum distillate will cause deterioration of the rubber parts. Oil spilled on any part will be difficult to wash off completely and will eventually deteriorate the rubber used in the disc brake.
7. When handling the disc pads or disc, be careful that no disc brake fluid or any oil gets on them. Clean off any fluid or oil that inadvertently gets on the pads or disc with a high-flash point solvent. Do not use one which will leave an oily residue. Replace the pads with new ones if they cannot be cleaned satisfactorily.
8. Brake fluid quickly ruins painted surfaces; any spilled fluid should be completely wiped up immediately.
9. If any of the brake line fittings or the bleed valve is opened at any time, the **AIR MUST BE BLED FROM THE BRAKE LINE.**

**Brake Hose**

---

*Brake Hose Removal/Installation*

- Refer to the Brake Hose and Pipe Replacement in the Periodic Maintenance chapter.

*Brake Hose Inspection*

- Refer to the Brake Hose Damage and Installation Connection Inspection in the Periodic Maintenance chapter.



# Suspension

## Table of Contents

Exploded View .....	13-2
Specifications .....	13-6
Special Tools .....	13-7
Front Fork .....	13-9
Rebound Damping Force Adjustment.....	13-9
Compression Damping Force Adjustment .....	13-9
Spring Preload Adjustment .....	13-10
Front Fork Removal (Each Fork Leg) .....	13-10
Front Fork Installation .....	13-11
Front Fork Oil Change .....	13-11
Front Fork Disassembly .....	13-15
Front Fork Assembly .....	13-16
Inner Tube Inspection .....	13-16
Dust Seal Inspection .....	13-17
Spring Tension .....	13-17
Rear Shock Absorber .....	13-18
Rebound Damping Force Adjustment.....	13-18
Compression Damping Force Adjustment .....	13-18
Spring Preload Adjustment .....	13-18
Rear Shock Absorber Removal .....	13-19
Rear Shock Absorber Installation .....	13-20
Rear Shock Absorber Inspection .....	13-20
Rear Shock Absorber Scrapping .....	13-20
Swingarm.....	13-21
Swingarm Removal.....	13-21
Swingarm Installation.....	13-22
Swingarm Bearing Removal .....	13-23
Swingarm Bearing Installation .....	13-24
Swingarm Bearing, Sleeve Inspection .....	13-24
Chain Guide Inspection.....	13-25
Tie-Rod, Rocker Arm .....	13-26
Tie-Rod Removal .....	13-26
Tie-Rod Installation .....	13-26
Rocker Arm Removal.....	13-26
Rocker Arm Installation.....	13-27
Tie-Rod and Rocker Arm Bearing Removal.....	13-27
Tie-Rod and Rocker Arm Bearing Installation.....	13-27
Rocker Arm/Tie-Rod Bearing, Sleeve Inspection .....	13-29
Rocker Arm/Tie-Rod Bearing Lubrication .....	13-29

# 13-2 SUSPENSION

## Exploded View

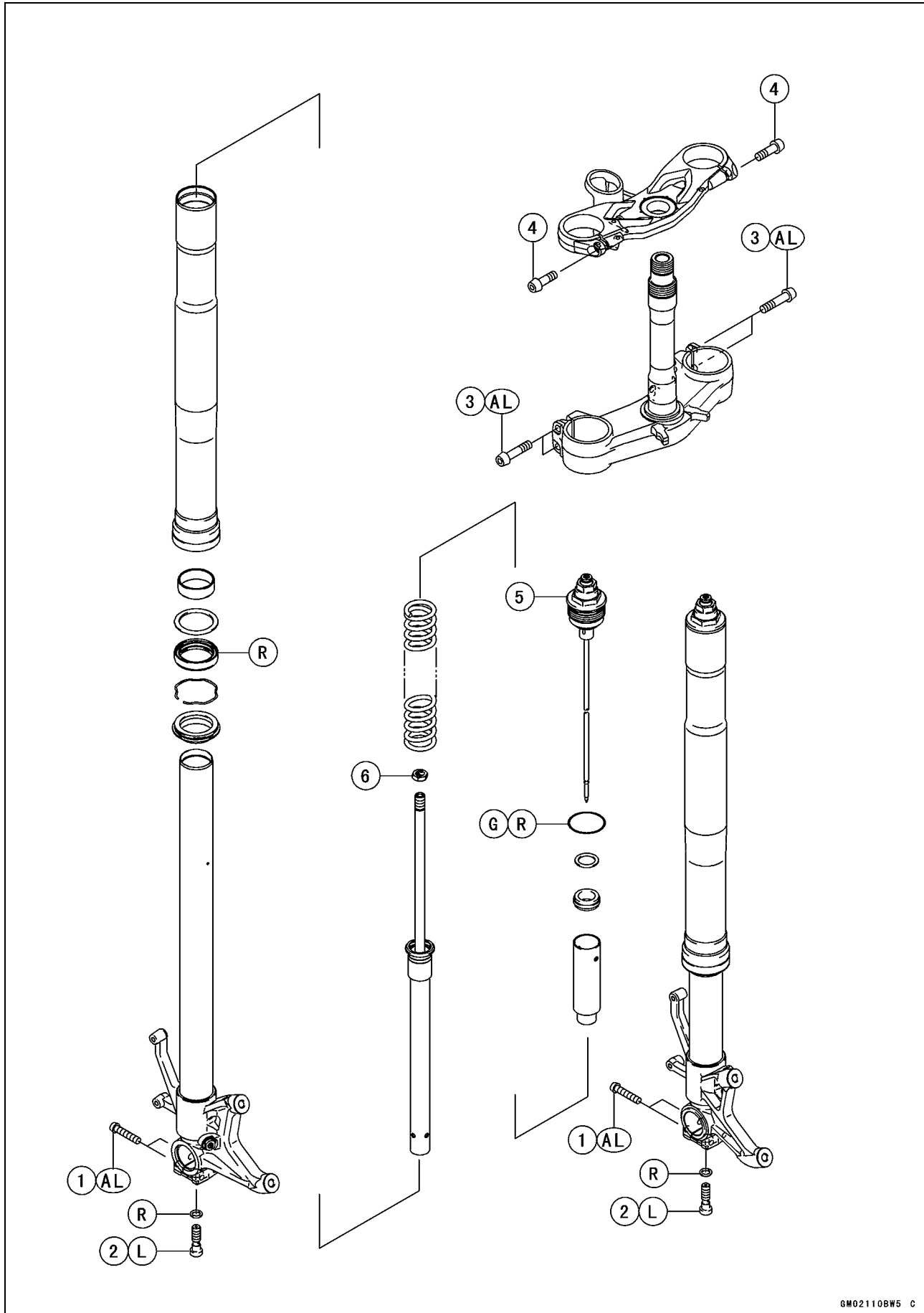

**Exploded View**

No.	Fastener	Torque			Remarks
		N·m	kgf·m	ft·lb	
1	Front Axle Clamp Bolts	20	2.0	15	AL
2	Front Fork Bottom Allen Bolts	35	3.5	26	L
3	Front Fork Clamp Bolts (Lower)	25	2.5	18	AL
4	Front Fork Clamp Bolts (Upper)	20	2.0	15	
5	Front Fork Top Plugs	35	3.5	26	
6	Piston Rod Nuts	20	2.0	15	

AL: Tighten the two clamp bolts alternately two times to ensure even tightening torque.

G: Apply grease.

L: Apply a non-permanent locking agent.

R: Replacement Parts

# 13-4 SUSPENSION

## Exploded View

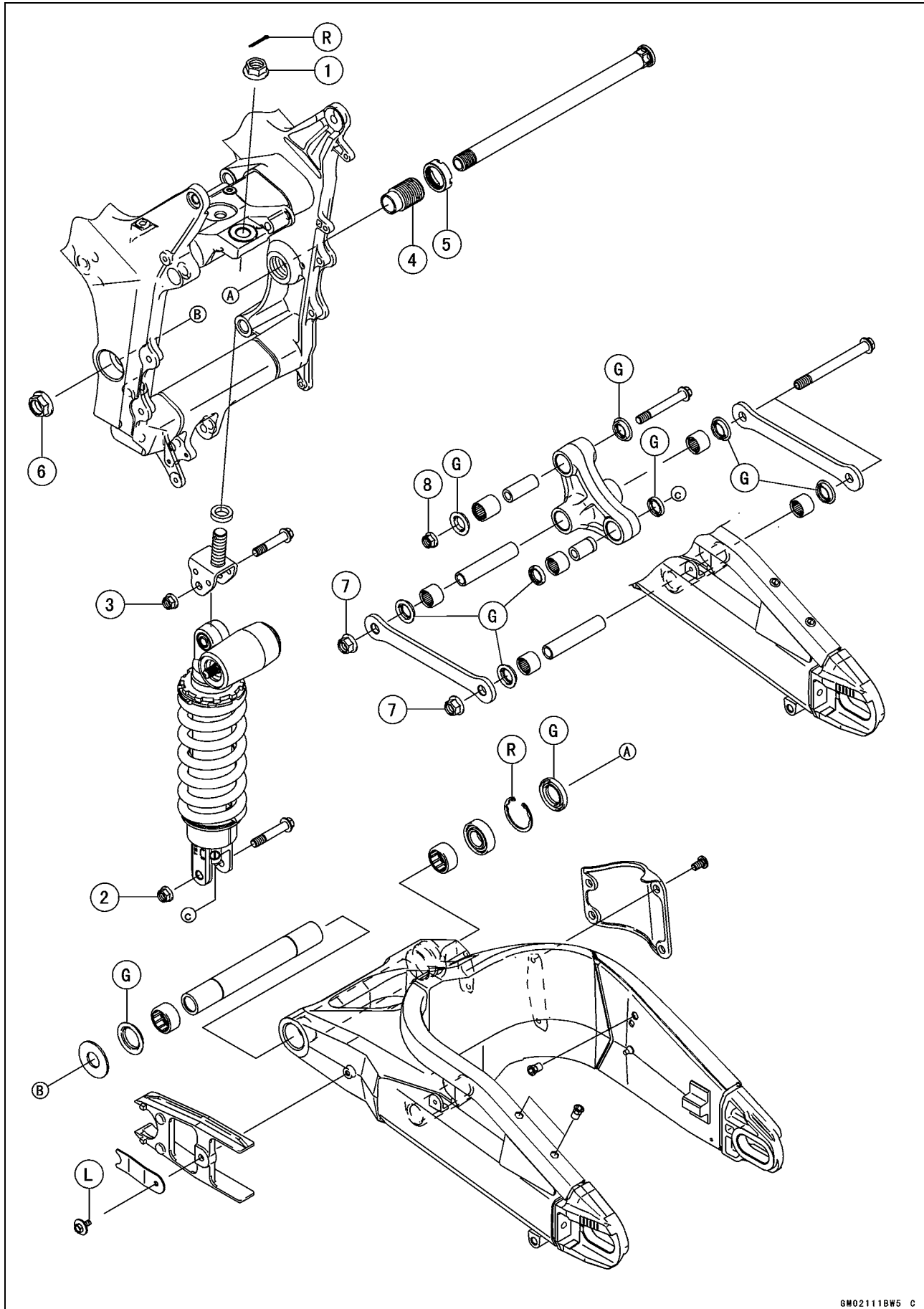

**Exploded View**

No.	Fastener	Torque			Remarks
		N·m	kgf·m	ft·lb	
1	Rear Shock Absorber Bracket Nut	59	6.0	43	
2	Rear Shock Absorber Nut (Lower)	34	3.5	25	
3	Rear Shock Absorber Nut (Upper)	34	3.5	25	
4	Swingarm Pivot Adjusting Collar	20	2.0	15	
5	Swingarm Pivot Adjusting Collar Locknut	98	10	72	
6	Swingarm Pivot Shaft Nut	108	11	81	
7	Tie-Rod Nuts	59	6.0	43	
8	Uni-Trak Rocker Arm Nut	34	3.5	25	

G: Apply grease.

L: Apply a non-permanent locking agent.

R: Replacement Parts

## 13-6 SUSPENSION

### Specifications

Item	Standard
<b>Front Fork (Per One Unit)</b> Fork Inner Tube Diameter Air Pressure Rebound Damper Setting Compression Damper Setting Fork Spring Preload Setting Fork Oil: Viscosity Amount: When Changing Oil After Disassembly and Completely Dry Fork Oil Level: (Fully Compressed, without Spring, below from the Top of the Inner Tube) Fork Spring Free Length	$\phi 41$ mm (1.6 in.) Atmospheric pressure (non-adjustable) 1 3/4 turns out from the fully clockwise position (Usable range: 0 $\longleftrightarrow$ 2 turns out) 3/4 turn out from the fully clockwise position (Usable range: 0 $\longleftrightarrow$ 2 turns out) Adjuster protrusion is 17 mm (0.67 in.) (Usable range: 10 ~ 25 mm) (0.39 ~ 0.98 in.) SS05 or equivalent SAE 5W Approx. 360 mL (12.2 US oz.) 426 $\pm$ 2 mL (14.4 $\pm$ 0.07 US oz.) 109 $\pm$ 2 mm (4.29 $\pm$ 0.08 in.) 247.6 mm (9.75 in.) (Service Limit: 243 mm (9.58 in.))
<b>Rear Shock Absorber</b> Rebound Damper Set Compression Damper Set Spring Preload Setting Position: Standard Usable Range Gas Pressure	9th click from the first click of the fully clockwise position (Usable range: 0 $\longleftrightarrow$ 2 turns out) 3/4 turn out from the fully clockwise position (Usable range: 0 $\longleftrightarrow$ 2 turns out) Spring length: 182.7 mm (7.19 in.) Spring length: 177.7 ~ 187.7 mm (6.996 ~ 7.390 in.) (weaker to stronger) 1 500 kPa (15.3 kgf/cm <sup>2</sup> , 218 psi, non-adjustable)

Special Tools

Inside Circlip Pliers:

57001-143

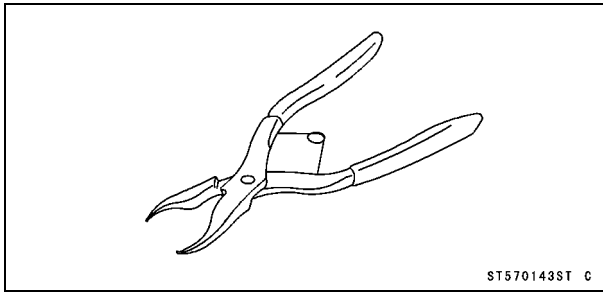

Fork Piston Rod Puller, M12 × 1.25:

57001-1289

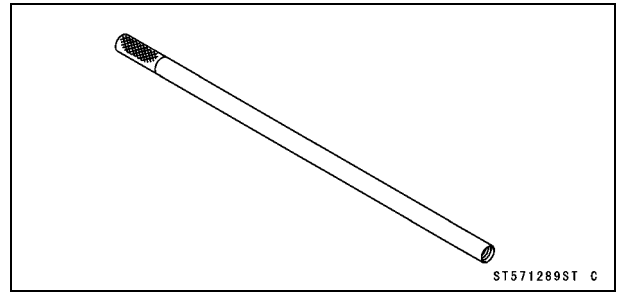

Oil Seal & Bearing Remover:

57001-1058

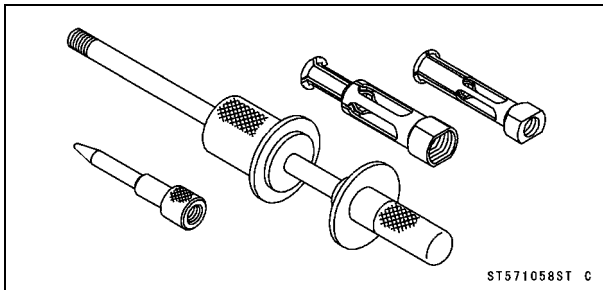

Fork Oil Level Gauge:

57001-1290

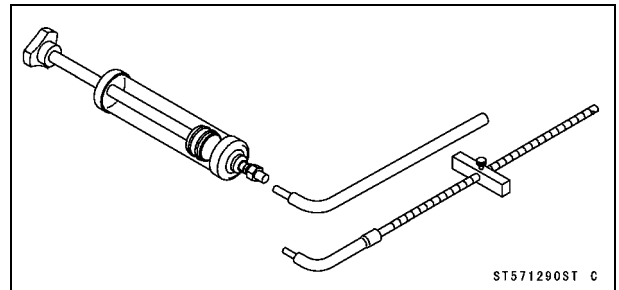

Bearing Driver Set:

57001-1129

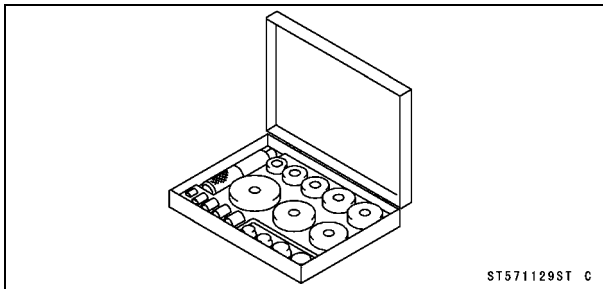

Bearing Remover Head,  $\phi 20 \times \phi 22$ :

57001-1293

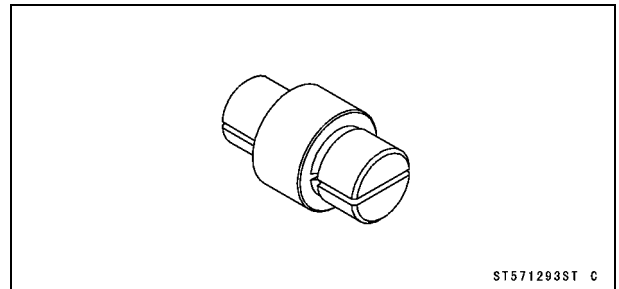

Jack:

57001-1238

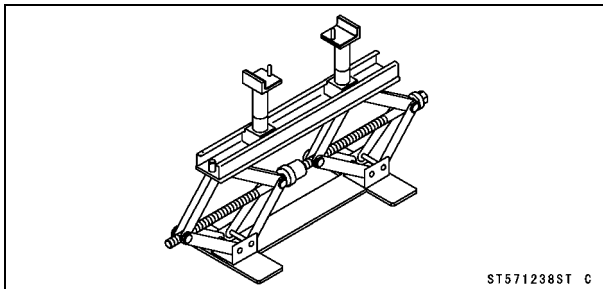

Bearing Remover Shaft,  $\phi 13$ :

57001-1377

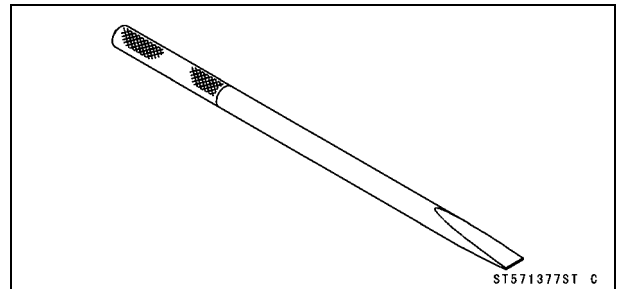

Fork Oil Seal Driver,  $\phi 41$ :

57001-1288

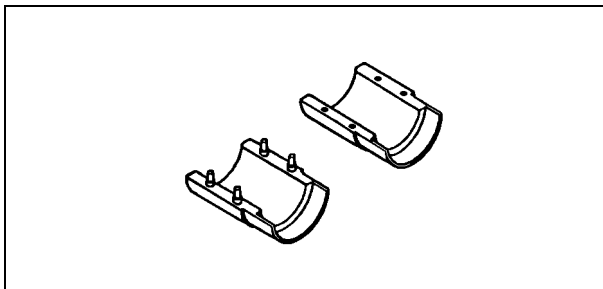

Fork Cylinder Holder, Hex 24:

57001-1537

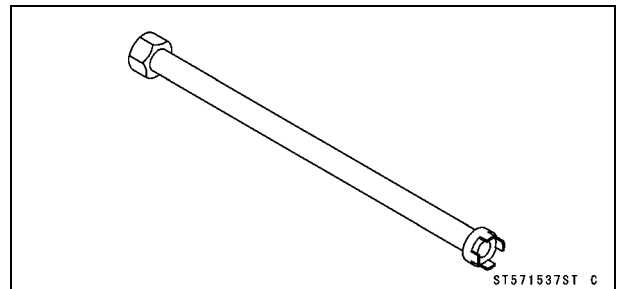

# 13-8 SUSPENSION

## Special Tools

**Hook Wrench T=3.2 R37:**

57001-1539

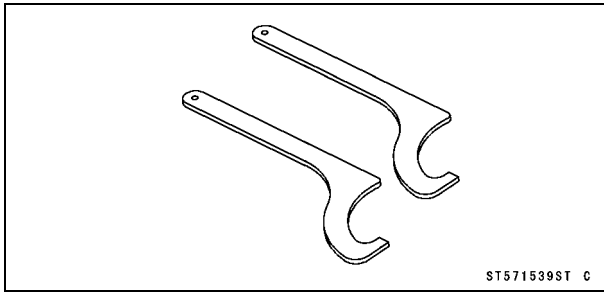

**Stem Bearing Driver,  $\phi 28$ :**

57001-1610

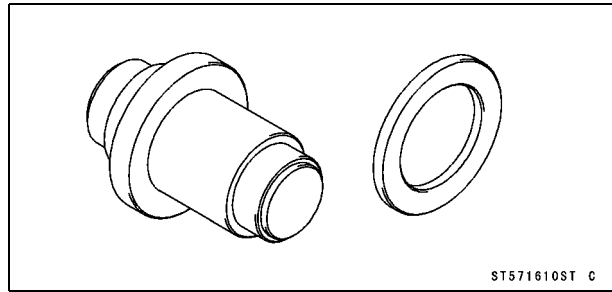

**Fork Spring Compressor:**

57001-1587

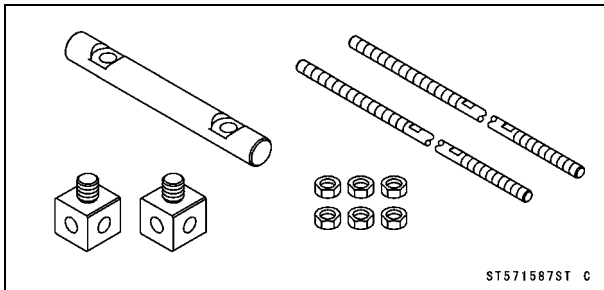

**Clamp:**

57001-1626

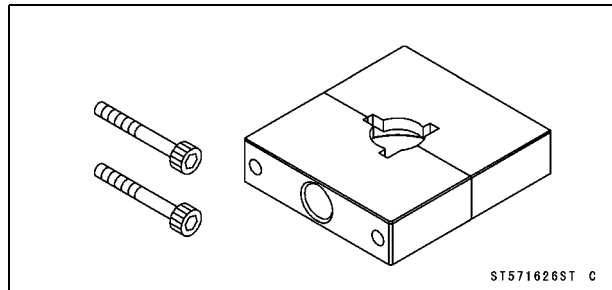

**Swingarm Pivot Nut Wrench:**

57001-1597

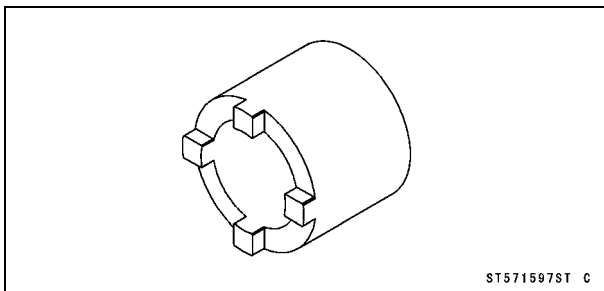

**Spacer,  $\phi 18$ :**

57001-1636

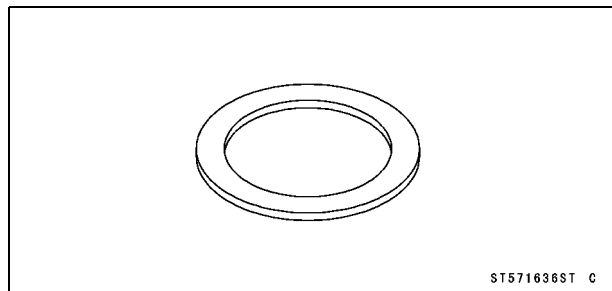

**Jack Attachment:**

57001-1608

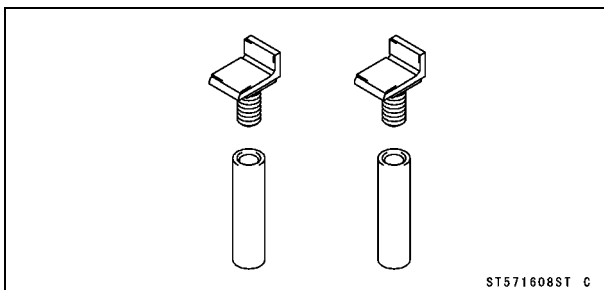

**Spacer,  $\phi 28$ :**

57001-1637

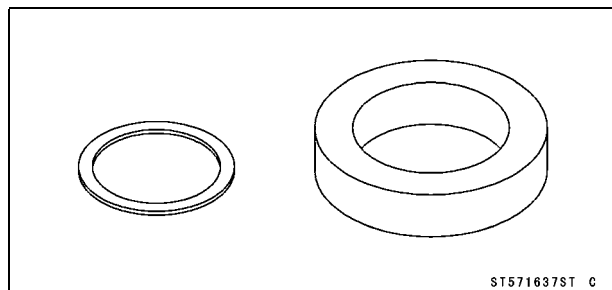

**Needle Bearing Driver,  $\phi 17/\phi 18$ :**

57001-1609

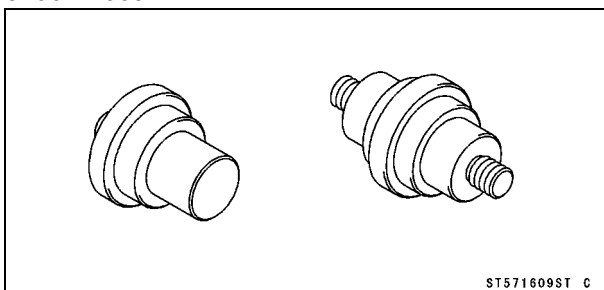

**Hook Wrench R37:**

57001-1641

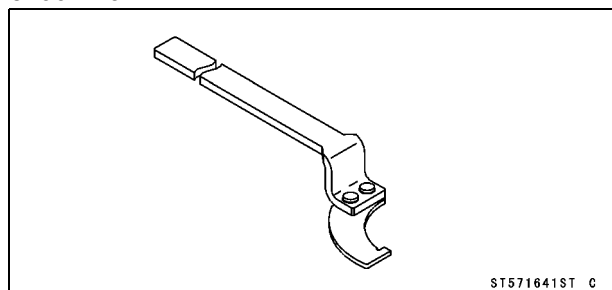

## Front Fork

### Rebound Damping Force Adjustment

- To adjust the rebound damping force, turn the rebound damping adjuster [A] until you feel a click.
- The standard adjuster setting for the average-build rider of 68 kg (150 lb) with no passenger and no accessories is the **1 3/4 turns out** from the fully clockwise position.

#### **⚠ WARNING**

**If both adjusters are not adjusted equally, handling may be impaired and a hazardous condition may result.**

- The damping force can be left soft for average riding. But it should be adjusted harder for high speed riding or riding with a passenger. If the damping feels too soft or too stiff, adjust it in accordance with the following table.

### Rebound Damping Force Adjustment

Adjuster Position	Damping Force	Setting	Load	Road	Speed
2 Turns Out	Weak	Soft	Light	Good	Low
↑	↑	↑	↑	↑	↑
↓	↓	↓	↓	↓	↓
0	Strong	Hard	Heavy	Bad	High

### Compression Damping Force Adjustment

- To adjust the compression damping force, turn the compression damping adjuster [A] until you feel a click.
- The standard adjuster setting for the average-build rider of 68 kg (150 lb) with no passenger and no accessories is the **3/4 turn out** from the fully clockwise position.

#### **⚠ WARNING**

**If both adjusters are not adjusted equally, handling may be impaired and a hazardous condition may result.**

- The damping force can be left soft for average riding. But it should be adjusted harder for high speed riding or riding with a passenger. If the damping feels too soft or too stiff, adjust it in accordance with the following table.

### Compression Damping Force Adjustment

Adjuster Position	Damping Force	Setting	Load	Road	Speed
2 Turns Out	Weak	Soft	Light	Good	Low
↑	↑	↑	↑	↑	↑
↓	↓	↓	↓	↓	↓
0	Strong	Hard	Heavy	Bad	High

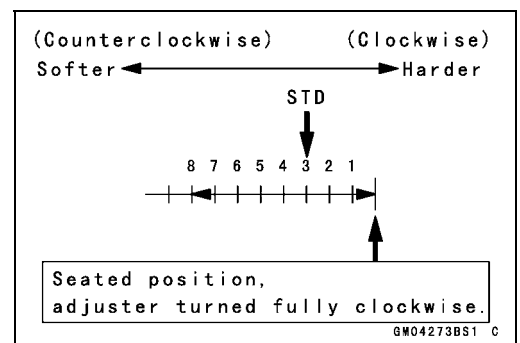
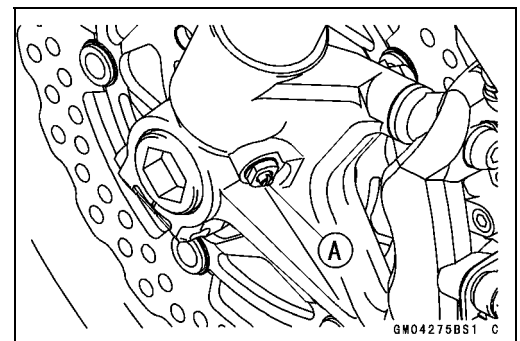
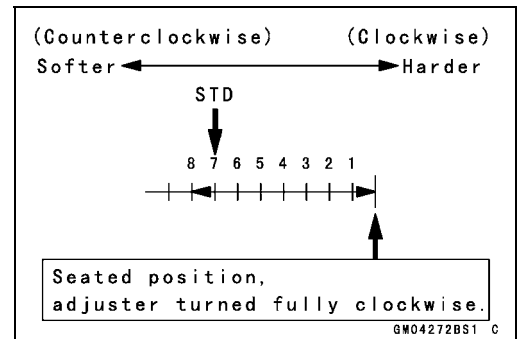
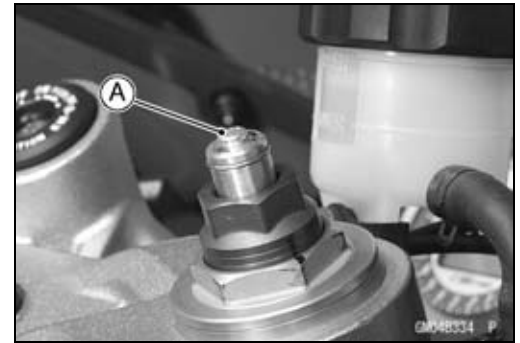

# 13-10 SUSPENSION

## Front Fork

### Spring Preload Adjustment

- Turn the spring preload adjuster [A] to change spring preload setting.
- The standard adjuster setting for the average-build rider of 68 kg (150 lb) with no passenger and no accessories is the 17 mm (0.67 in.) [B] from top as shown.

#### Adjuster Protrusion (from top)

- Standard: 17 mm (0.67 in.)
- Usable Range: 10 ~ 25 mm (0.39 ~ 0.98 in.)

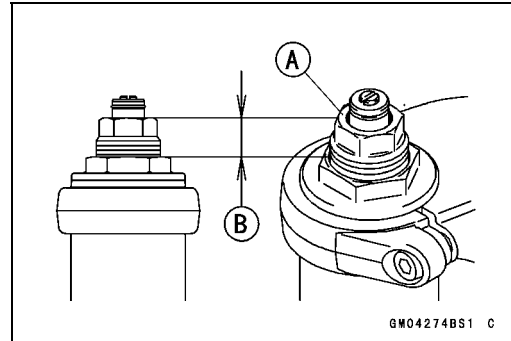

### ⚠ WARNING

If both adjusters are not adjusted equally, handling may be impaired and a hazardous condition may result.

- The spring preload can be left soft for average riding. But it should be adjusted harder for high speed riding or riding with a passenger. If the spring action feels too soft or too stiff, adjust it in accordance with the following table.

### Spring Action

Adjuster Position	Damping Force	Setting	Load	Road	Speed
25 mm	Weak	Soft	Light	Good	Low
↑	↑	↑	↑	↑	↑
↓	↓	↓	↓	↓	↓
10 mm	Strong	Hard	Heavy	Bad	High

### Front Fork Removal (Each Fork Leg)

- Remove:
  - Center Fairings (see Center Fairing Removal in the Frame chapter)
  - Upper Inner Fairings (see Upper Inner Fairing Removal in the Frame chapter)
  - Front Wheel (see Front Wheel Removal in the Wheels/Tires chapter)
  - Front Fender (see Front Fender Removal in the Frame chapter)
- ★ Loosen the handlebar bolt [A], upper fork clamp bolt [B] and fork top plug [D] beforehand if the fork leg is to be disassembled.

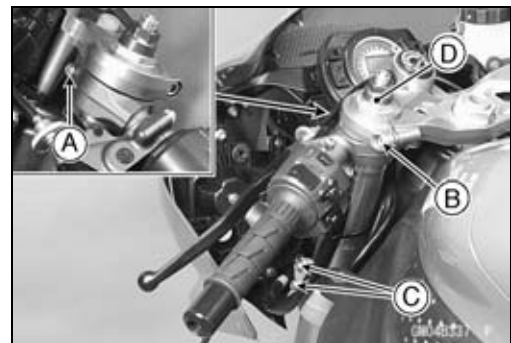

### NOTE

○ Loosen the top plug after loosening the handlebar bolt and upper fork clamp bolt.

- Loosen the handlebar bolt [A], upper fork clamp bolt [B] and lower fork clamp bolts [C].
- With a twisting motion, work the fork leg down and out.

## Front Fork

### Front Fork Installation

- Install the fork so that the top end [A] of the outer tube as shown.  
6.5 mm (0.26 in.) [B]
- Tighten the lower fork clamp bolts and fork top plug.  
**Torque - Front Fork Clamp Bolts (Lower): 25 N·m (2.5 kgf·m, 18 ft·lb)**  
**Front Fork Top Plug: 35 N·m (3.5 kgf·m, 26 ft·lb)**
- Tighten the handlebar bolt and upper fork clamp bolt.  
**Torque - Handlebar Bolt: 25 N·m (2.5 kgf·m, 18 ft·lb)**  
**Front Fork Clamp Bolt (Upper): 20 N·m (2.0 kgf·m, 15 ft·lb)**

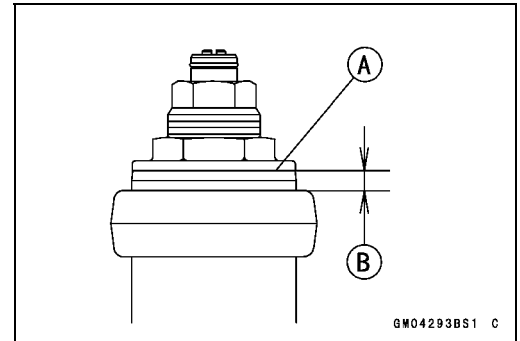

### NOTE

- Tighten the two clamp bolts alternately two times to ensure even tightening torque.
- Tighten the top plug before tightening the handlebar bolt and upper fork clamp bolt.
- Install the removed parts (see appropriate chapters).
- Adjust the spring preload and the damping force.

### Front Fork Oil Change

- Remove the front fork (see Front Fork Removal in this chapter).
- Hold the inner tube lower end in a vise.
- Unscrew the top plug [A] out of the outer tube.



- Install the clamps [A] as shown.

### NOTE

- Set the three grooves of clamp to the three pins [B] of front fork, pull up the outer tube [C] to hold it by the clamps, and then tighten the two bolts [D].

**Special Tools - Fork Spring Compressor: 57001-1587**  
**Clamp: 57001-1626**

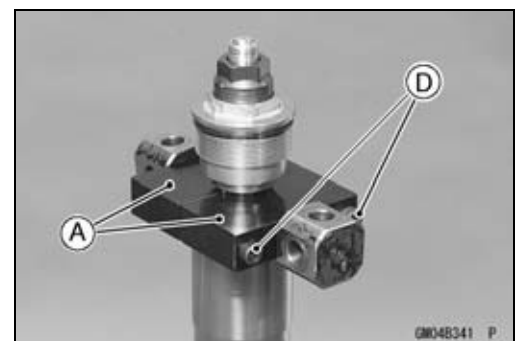
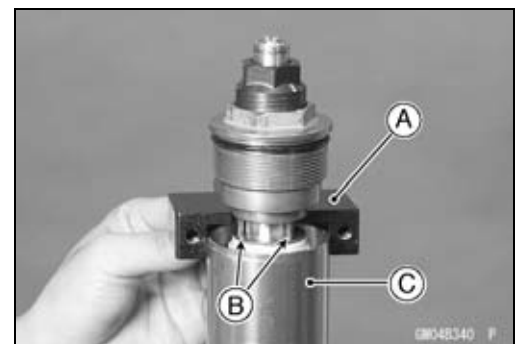

# 13-12 SUSPENSION

## Front Fork

- Insert the holder bar [A] into the axle hole of the front fork [B].

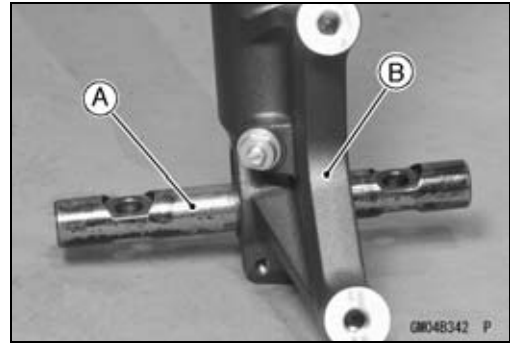

- Insert the compression shaft and install the nut.
- Insert the lower end of the compression shaft [A] into the hole [B] of the holder bar.

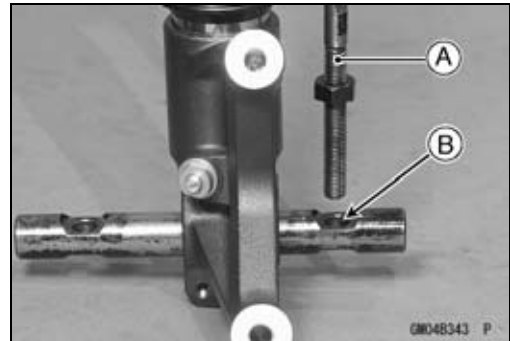

- Screw the adjust nut [A] onto the compression shaft as shown.
- Screw the locknut [B].  
About 20 mm (0.79 in.) [C]
- Set the other side compression shaft same process.

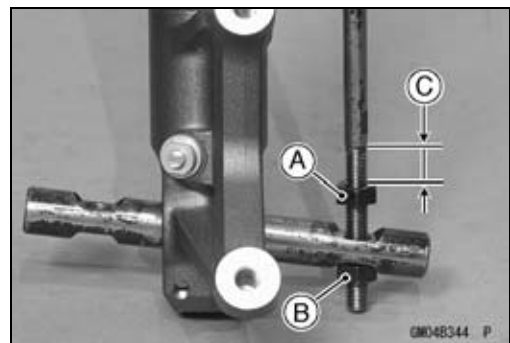

- Set the holder bar [A] and compression shafts [B].

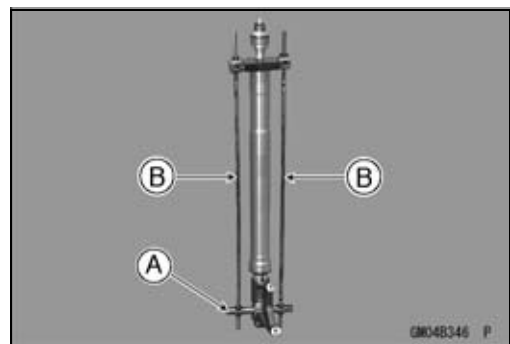

- Screw in nuts [A] come out the piston rod nut.



## Front Fork

- Holding the piston rod nut with a wrench [A], remove the top plug assy [B] from the piston rod.

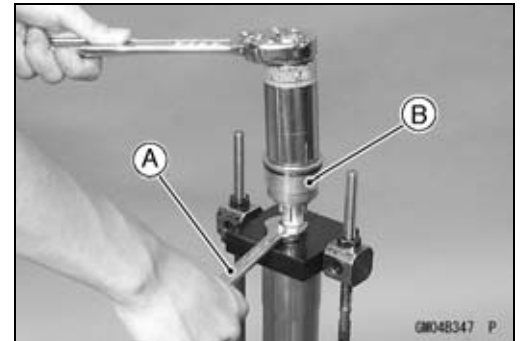

- Remove:
  - Washer [A]
  - Collar [B]
  - Collar [C]
  - Fork Spring [D]

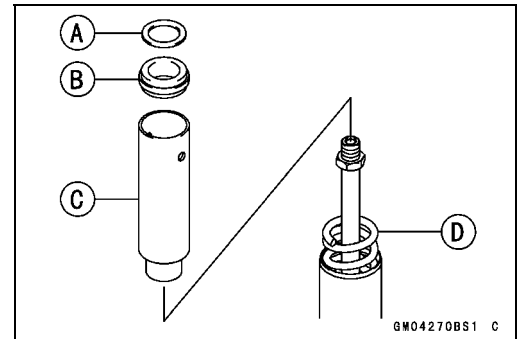

- Drain the fork oil into a suitable container.
- Pump the piston rod [B] up and down at least ten times to expel the oil from the fork.

**Special Tool - Fork Piston Rod Puller, M12 × 1.25 [A]: 57001-1289**

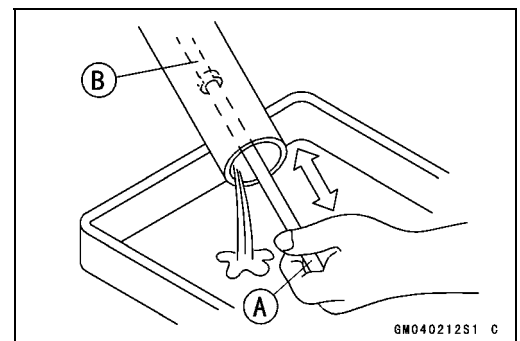

- Hold the fork tube upright, press the inner tube [A] and the piston rod all the way down.
- Pour in the type and amount of fork oil specified.

### Fork Oil

**Viscosity: SS05 or equivalent SAE 5W**

**Amount (per side):**

**When changing oil: approx. 360 mL (12.2 US oz.)**

**After disassembly and completely dry:**

**426 ±2 mL (14.4 ±0.07 US oz.)**

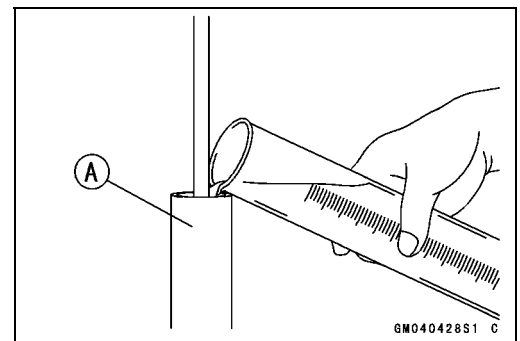

- ★ If necessary, measure the oil level as follows.

- Hold the inner tube vertically in a vise.
- Pump the inner tube several times to expel air bubbles.
- Using the piston rod puller [A], move the piston rod [B] up and down more than ten times in order to expel all the air from the fork oil.

**Special Tool - Fork Piston Rod Puller, M12 × 1.25: 57001-1289**

- Remove the piston rod puller.
- Wait until the oil level settles.
- With the fork fully compressed and the piston rod fully pushed in, insert a tape measure or rod into the inner tube, and measure the distance from the top of the outer tube to the oil.

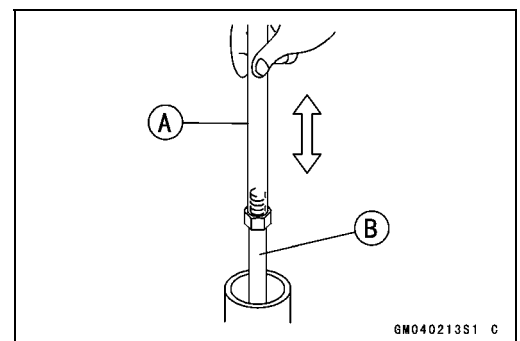

# 13-14 SUSPENSION

## Front Fork

Oil Level (fully compressed, without spring)

Standard: 109 ±2 mm (4.29 ±0.08 in.)

(from the top of the outer tube)

### NOTE

○Fork oil level may also be measured using the fork oil level gauge.

**Special Tool - Fork Oil Level Gauge [A]: 57001-1290**

- With the fork fully compressed and without fork spring, insert the gauge tube into the inner tube [B] and position the stopper across the top end [F] of the outer tube [C].
- Set the gauge stopper [D] so that its lower side shows the oil level distance specified [E].
- Pull the handle slowly to pump out the excess oil until the oil no longer comes out.
- ★If no oil is pumped out, there is insufficient oil in the inner tube. Pour in enough oil, then pump out the excess oil as shown above.

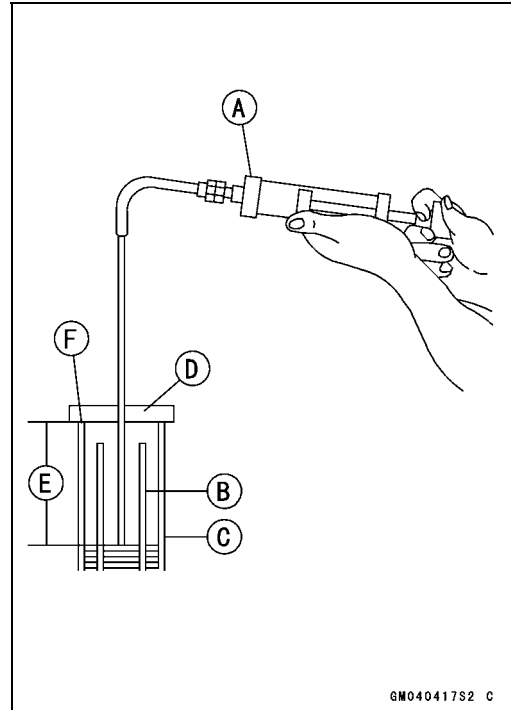

- Screw the fork piston rod puller onto the end of the piston rod.

**Special Tool - Fork Piston Rod Puller, M12 × 1.25: 57001-1289**

- Pull the puller up above the outer tube top.
- Install the fork spring [A] with the smaller end facing [B] upward.
- Install:
  - Collar
  - Collar
  - Washer

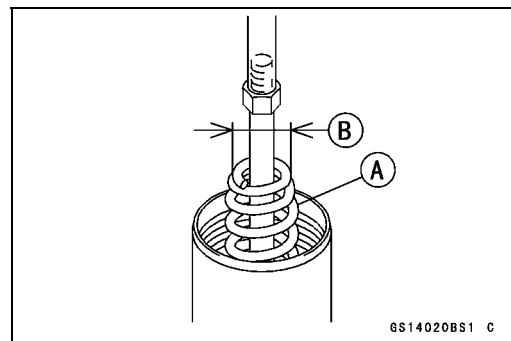

- Set the fork spring compressor to the pins of front fork using the outer tube as a guide.

**Special Tools - Fork Spring Compressor: 57001-1587**  
**Clamp: 57001-1626**

### NOTE

○Set the three grooves of clamp to the three pins of front fork, pull up the outer tube to hold it by the clamps, and then tighten the two bolts.

- Hold the piston rod nut [A].
- Remove the piston rod puller [B].

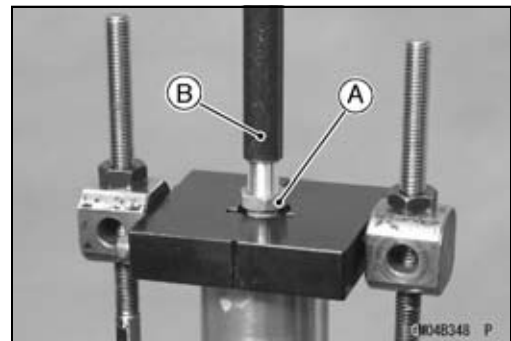

## Front Fork

- Screw in the top plug assy [A] stopped onto the piston rod.
- Check the O-ring [B] on the top plug and replace it with a new one if damaged.
- Holding the top plug with a wrench, tighten the piston rod nut [C] against the top plug.

**Torque - Piston Rod Nut: 20 N·m (2.0 kgf·m, 15 ft·lb)**

- While holding up the fork spring compressor, pull out the fork spring stopper.
- Remove the fork spring compressor.

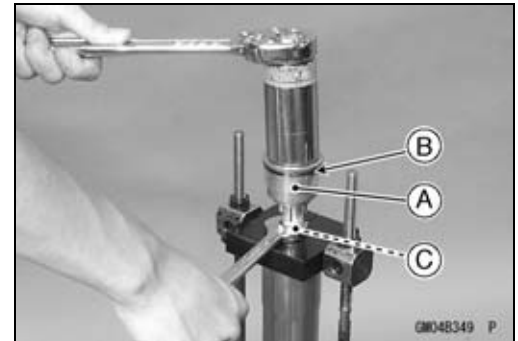

- Raise the outer tube and screw the top plug into it and install it to the steering stem.
- Screw in the spring preload adjuster [A] of the top plug so that the distance between the adjuster top and the top plug surface is 17 mm (0.67 in.) [B].
- Turn in the rebound damping adjuster until the fully tightened position and turn backward the 1 3/4 turns out.
- Install the front fork (see Front Fork Installation in this chapter).

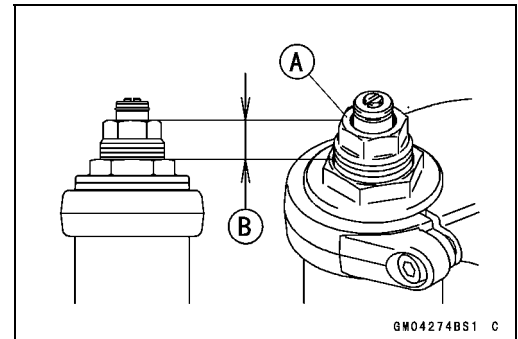

### Front Fork Disassembly

- Remove the front fork (see Front Fork Removal in this chapter).
- Drain the fork oil (see Front Fork Oil Change in this chapter).
- Hold the front fork in a vise [A].
- Stop the cylinder [B] from turning by using the fork cylinder holder [C].

**Special Tool - Fork Cylinder Holder: 57001-1537**

- Unscrew the Allen bolt [D], then take the bolt and gasket out of the bottom of the inner tube.
- Take the cylinder unit [A].
- Do not disassemble the cylinder unit.

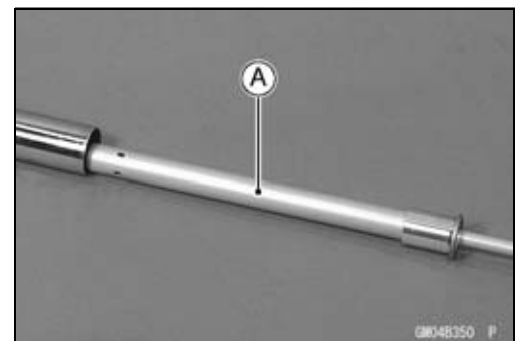
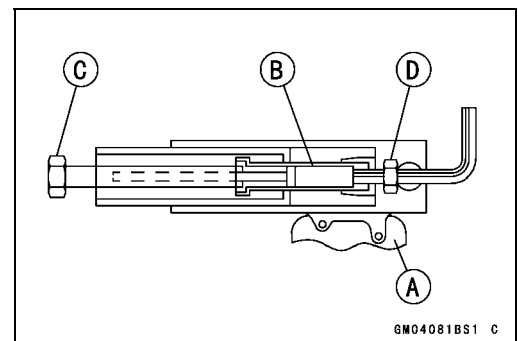

## 13-16 SUSPENSION

### Front Fork

- Separate the outer tube from the inner tube.
- Pull out the dust seal.
- Remove the retaining ring [A] from the outer tube.
- Remove the oil seal [B] and washer [C].

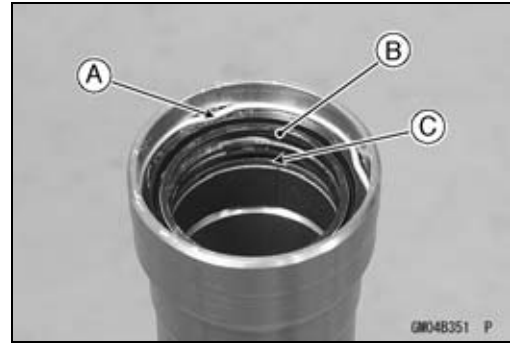

#### Front Fork Assembly

- Replace the following parts with a new one.
  - Oil Seal
  - Bottom Allen Bolt Gasket
- Insert the cylinder unit [A] into the inner tube [B].
- Stop the cylinder from turning by using the fork cylinder holder.

**Special Tool - Fork Cylinder Holder: 57001-1537**

- Apply a non-permanent locking agent to the Allen bolt and tighten it.

**Torque - Front Fork Bottom Allen Bolt: 35 N·m (3.5 kgf·m, 26 ft·lb)**

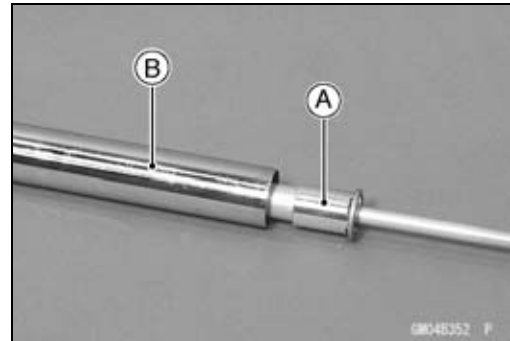

- Install the following parts into the inner tube [A].
  - Dust Seal [B]
  - Retaining Ring [C]
  - Oil Seal [D]
  - Washer [E]

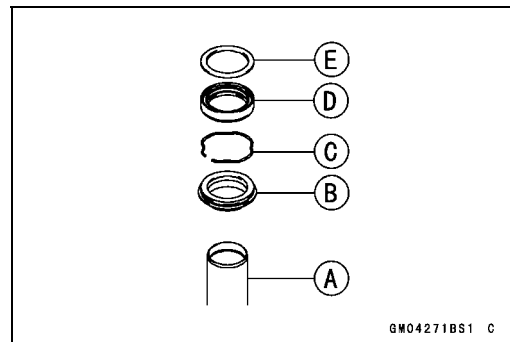

- Insert the inner tube to the outer tube.
- After installing the washer, install the oil seal [A] by using the fork oil seal driver [B].

**Special Tool - Fork Oil Seal Driver,  $\phi 41$ : 57001-1288**

- Install the retaining ring and dust seal into the outer tube.
- Pour in the specified type of oil (see Front Fork Oil Change in this chapter).

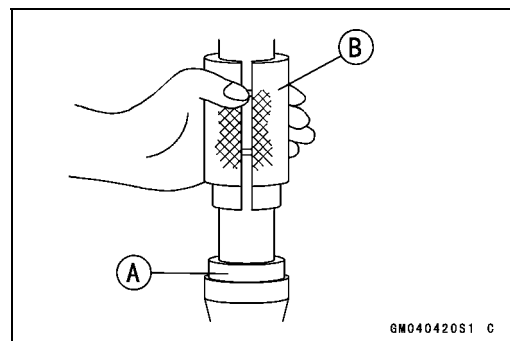

#### Inner Tube Inspection

- Visually inspect the inner tube [A], and repair any damage.
- Nicks or rust damage can sometimes be repaired by using a wet-stone to remove sharp edges or raised areas which cause seal damage.
- ★ If the damage is not repairable, replace the inner tube. Since damage to the inner tube damages the oil seal, replace the oil seal whenever the inner tube is repaired or replaced.

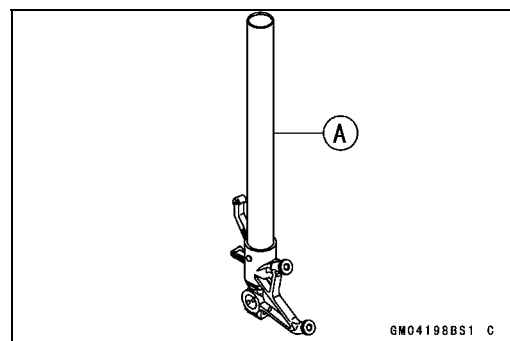

## Front Fork

### CAUTION

If the inner tube is badly bent or creased, replace it. Excessive bending, followed by subsequent straightening, can weaken the inner tube.

- Temporarily assemble the inner and outer tubes, and pump them back and forth manually to check for smooth operation.
- If you feel binding or catching, the inner and outer tubes must be replaced.

### ⚠ WARNING

A straightened inner or outer fork tube may fall in use, possibly causing an accident. Replace a badly bent or damaged inner or outer tube and inspect the other tube carefully before reusing it.

### Dust Seal Inspection

- Inspect the dust seals [A] for any signs of deterioration or damage.
- ★ Replace it if necessary.

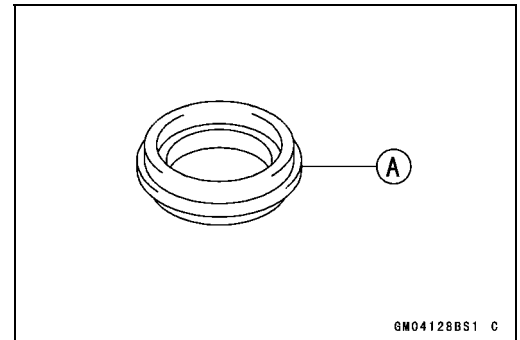

### Spring Tension

- Since a spring becomes shorter as it weakens, check its free length [A] to determine its condition.
- ★ If the spring of either fork leg is shorter than the service limit, it must be replaced. If the length of a replacement spring and that of the remaining spring vary greatly, the remaining spring should also be replaced in order to keep the fork legs balanced for motorcycle stability.

### Spring Free Length

Standard: 247.6 mm (9.75 in.)

Service Limit: 243 mm (9.58 in.)

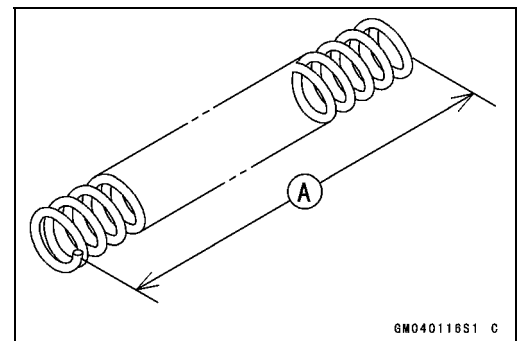

# 13-18 SUSPENSION

## Rear Shock Absorber

### Rebound Damping Force Adjustment

- To adjust the rebound damping force, turn the lower damping adjuster [A] to the desired position, until you feel a click.
- The standard adjuster setting for an average-build rider of 68 kg (150 lb) with no passenger and no accessories is the **9th click** from the 1st click of the fully clockwise position.

### Rebound Damping Force Adjustment

Adjuster Position	Damping Force	Setting	Load	Road	Speed
2 Turns Out	Weak	Soft	Light	Good	Low
↑	↑	↑	↑	↑	↑
↓	↓	↓	↓	↓	↓
0	Strong	Hard	Heavy	Bad	High

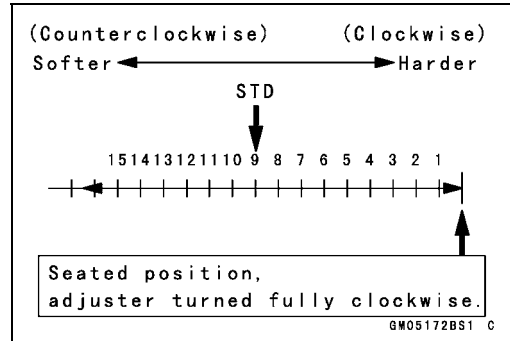
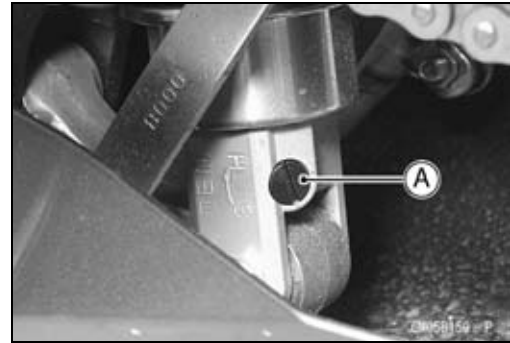

### Compression Damping Force Adjustment

- To adjust the compression damping force, turn the upper damping adjuster [A] to the desired position until you feel a click.
- The standard adjuster setting for the average-build rider of 68 kg (150 lb) with no passenger and no accessories is the **3/4 turn out** from the fully clockwise position.

### Rebound Damping Force Adjustment

Adjuster Position	Damping Force	Setting	Load	Road	Speed
2 Turns Out	Weak	Soft	Light	Good	Low
↑	↑	↑	↑	↑	↑
↓	↓	↓	↓	↓	↓
0	Strong	Hard	Heavy	Bad	High

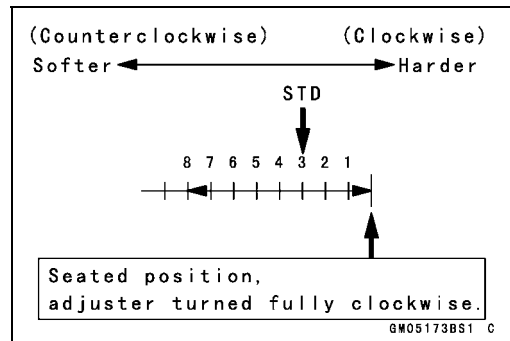
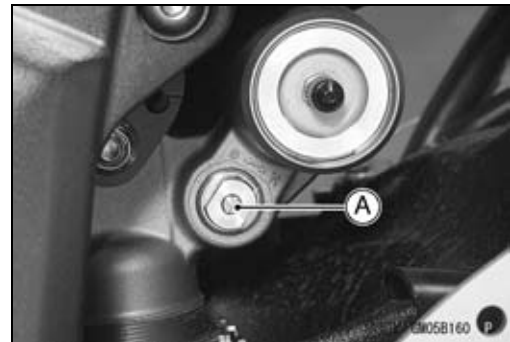

### Spring Preload Adjustment

- Remove the rear shock absorber from the frame (see Rear Shock Absorber Removal in this chapter).
- Loosen the locknut and turn out the adjusting nut to free the spring.

**Special Tools - Hook Wrench T=3.2 R37: 57001-1539**  
**Hook Wrench R37: 57001-1641**

## Rear Shock Absorber

- To adjust the spring preload, turn in the adjusting nut [A] to the desired position and tighten the locknut [B].  
Spring Length [C]

### Spring Preload Setting

**Standard:** Spring length 182.7 mm (7.19 in.)

**Usable Range:** Spring length 177.7 ~ 187.7 mm (6.996 ~ 7.390 in.)

- The standard adjusting nut setting for an average-build rider of 68 kg (150 lb) with no passenger and no accessories is 180 mm (7.0 in.) spring length.

- Remove the bolts [A], chain cover [B] and left foot guard [C] for turning the hook wrench easily.

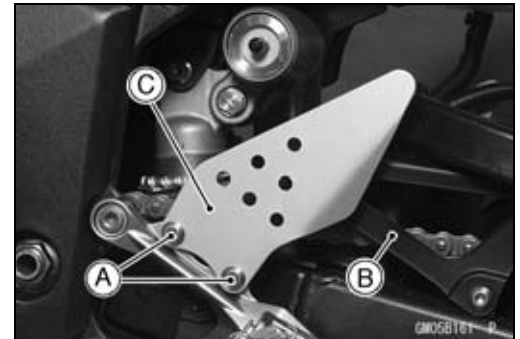
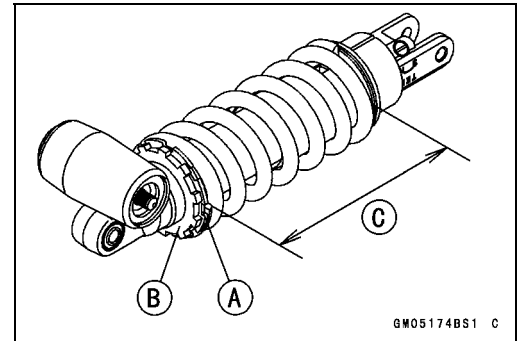

- To adjust the spring preload, turn in the adjusting nut to the desired position and tighten the locknut by using hook wrenches [A] with the rear shock absorber attached the frame.

**Special Tools - Hook Wrench T=3.2 R37: 57001-1539**

**Hook Wrench R37: 57001-1641**

- ★ If the spring action feels too soft or too stiff, adjust it.

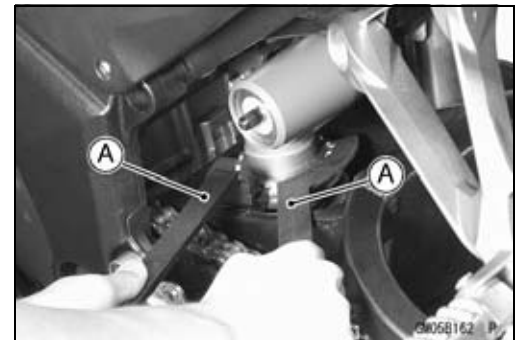

### Spring Adjustment

Adjuster Position	Damping Force	Setting	Load	Road	Speed
187.7 mm (7.390 in.)	Weak	Soft	Light	Good	Low
↑	↑	↑	↑	↑	↑
↓	↓	↓	↓	↓	↓
177.7 mm (6.996 in.)	Strong	Hard	Heavy	Bad	High

### Rear Shock Absorber Removal

- Remove:  
Lower Fairings (see Lower Fairings Removal in the Frame chapter).
- Using the jack, raise the rear wheel off the ground.

**Special Tools - Jack: 57001-1238**

**Jack Attachment: 57001-1608**

- Squeeze the brake lever slowly and it with a band [A].

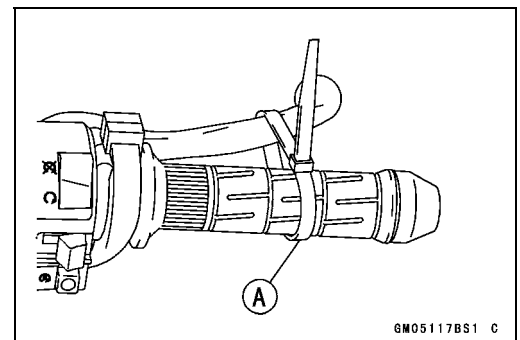

### **⚠ WARNING**

**Be sure to hold the front brake when removing the shock absorber, or the motorcycle may fall over. It could cause an accident and injury.**

## 13-20 SUSPENSION

### Rear Shock Absorber

- Remove:
  - Lower Shock Absorber Nut and Bolt [A]
  - Upper Tie-Rod Nut and Bolt [B]
  - Upper Shock Absorber Nut and Bolt [C]
- Remove the shock absorber downward.

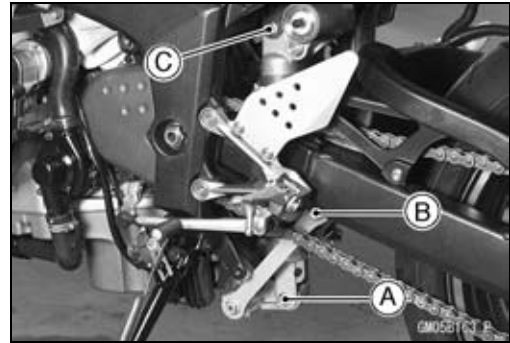

#### Rear Shock Absorber Installation

- Tighten:
  - Torque - Rear Shock Absorber Nuts: 34 N·m (3.5 kgf·m, 25 ft·lb)**
  - Tie-Rod Nuts: 59 N·m (6.0 kgf·m, 43 ft·lb)**

#### Rear Shock Absorber Inspection

- Remove the rear shock absorber (see Rear Shock Absorber Removal in this chapter).
- Visually inspect the following items.
  - Smooth Stroke
  - Oil Leakage
  - Crack or Dent
- ★ If there is any damage to the rear shock absorber, replace it.
- Visually inspect the bushing.
- ★ If it show any signs of damage, replace it.

#### Rear Shock Absorber Scrapping

##### **⚠ WARNING**

Since the reservoir tank of the rear shock absorber contains nitrogen gas, do not incinerate the reservoir tank without first releasing the gas or it may explode.

- Remove the valve cap and release the nitrogen gas completely from the gas reservoir.
- Remove the valve [A].

##### **⚠ WARNING**

Since the high pressure gas is dangerous, do not point the valve toward your face or body.

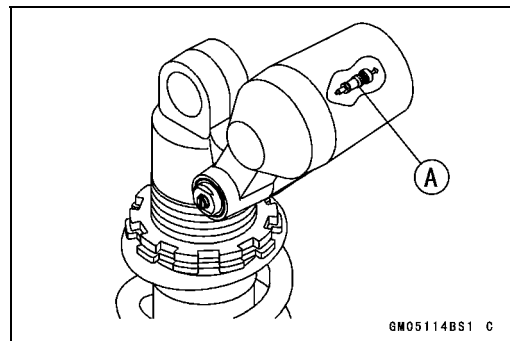

## Swingarm

### Swingarm Removal

- Remove:
  - Bolts [A]
  - Chain Cover [B]
  - Rear Wheel (see Rear Wheel Removal in the Wheels/Tires chapter)
  - Engine Sprocket (see Engine Sprocket Removal in the Final Drive chapter)
  
- Remove:
  - Bolt [A]
  - Brake Hose Clamp [B]
  
- Remove the brake pedal (see Brake Pedal Removal in the Brakes chapter).
- Remove:
  - Bolts [A]
  - Cover [B]
  - Center Pipe (see Muffler Body Removal in the Engine Top End chapter)
  
- Remove:
  - Upper Tie-Rod Nut and Bolt [A]
  - Rear Shock Absorber [B] (see Rear Shock Absorber Removal in this chapter)
  - Drive Chain (see Drive Chain Removal in the Final Drive chapter)
  
- Unscrew the swingarm pivot shaft locknut [A].

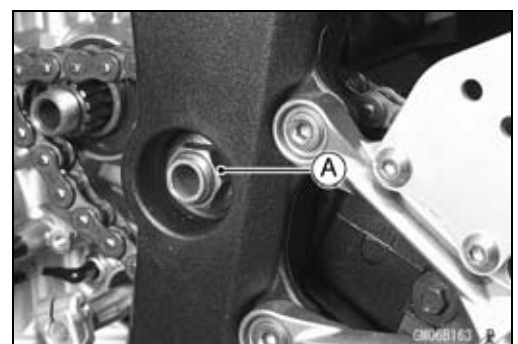
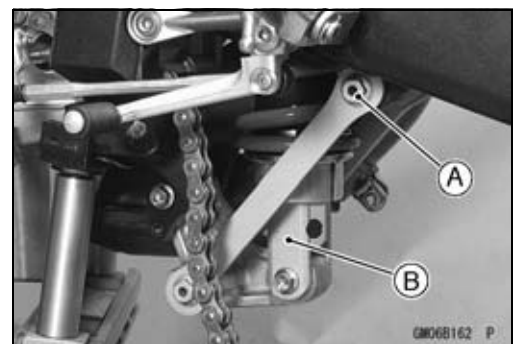
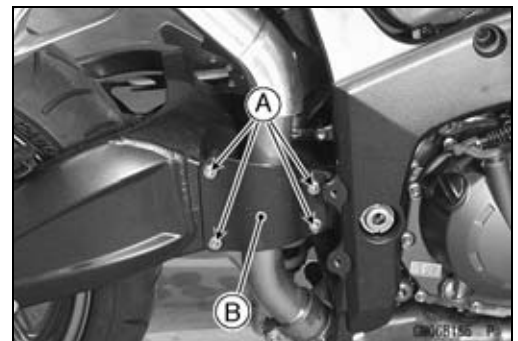
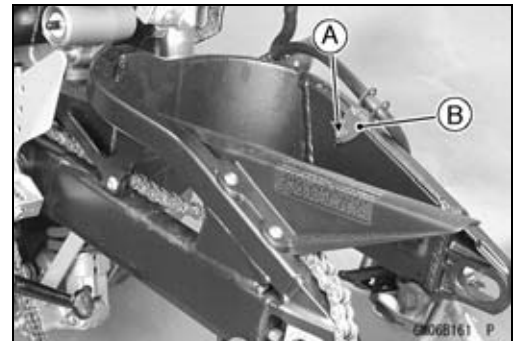
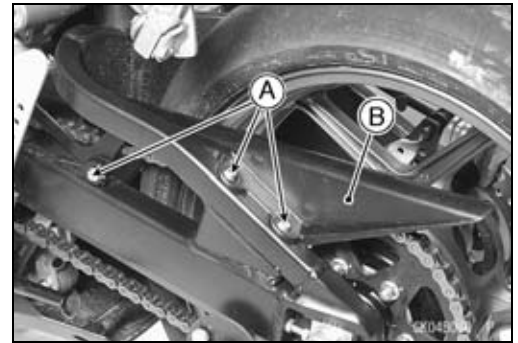

## 13-22 SUSPENSION

### Swingarm

- Unscrew the swingarm pivot collar locknut [A] using the nut wrench [B].

**Special Tool - Swingarm Pivot Nut Wrench: 57001-1597**

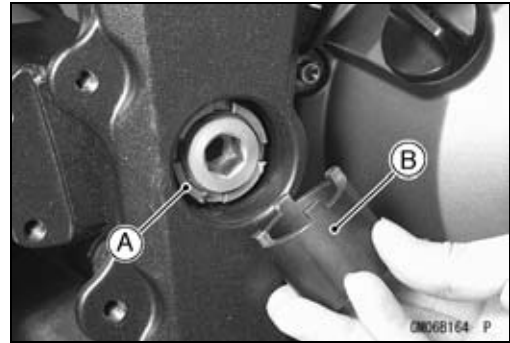

- Unscrew the swingarm pivot shaft [A] few times.
- Turn out the swingarm pivot adjusting collar [B].
- Pull out the pivot shaft right side of the motorcycle and remove the swingarm.

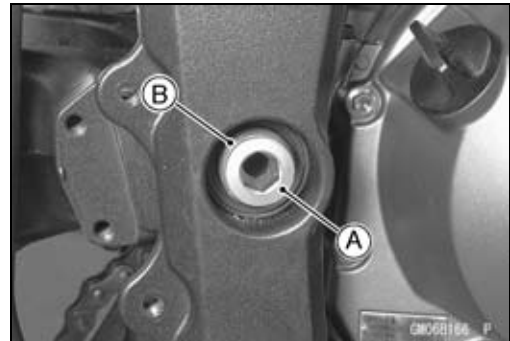

#### Swingarm Installation

- Apply plenty of grease to the lip [A] of the oil seals.
- Install the oil seal.

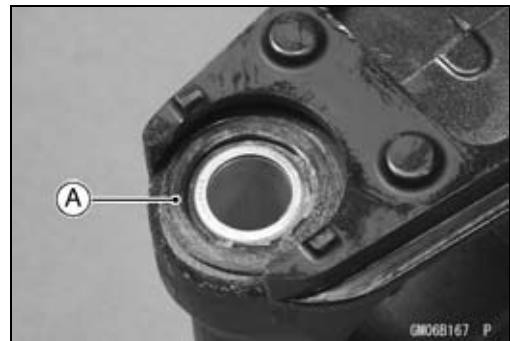

- Place the adjusting collar [A] the frame [B] as shown.

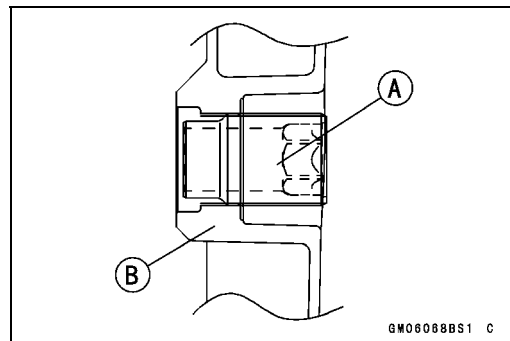

- Insert the pivot shaft [A] into the frame from the right side.
- Tighten the pivot shaft so that the clearance between the adjusting collar [B] and the ball bearing [C] come to 0 mm (0 in.).

**Torque - Swingarm Pivot Adjusting Collar: 20 N·m (2.0 kgf·m, 15 ft·lb)**

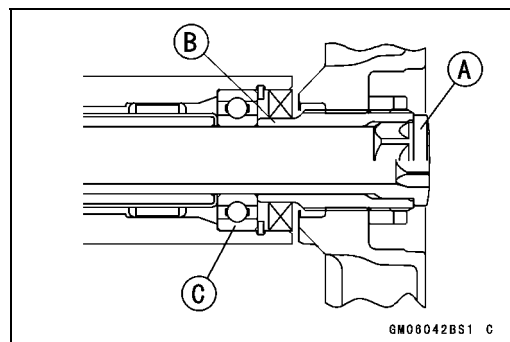

## Swingarm

- Be sure to install the washer [A].

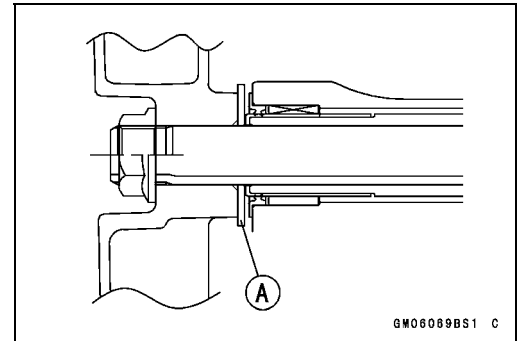

- Tighten the adjusting collar locknut [A] with the swingarm pivot nut wrench [B].

**Special Tool - Swingarm Pivot Nut Wrench: 57001-1597**

**Torque - Swingarm Pivot Adjusting Collar Locknut: 98 N·m (10 kgf·m, 72 ft·lb)**

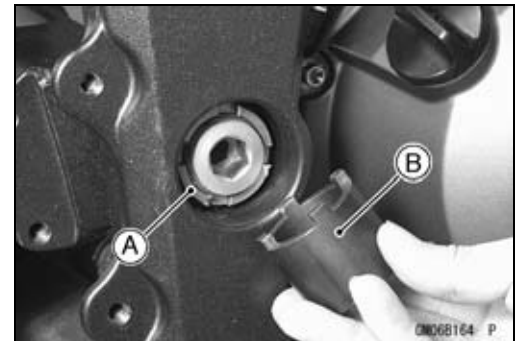

- Tighten the pivot shaft nut [A].

**Torque - Swingarm Pivot Shaft Nut: 108 N·m (11 kgf·m, 81 ft·lb)**

- Install the removed parts (see appropriate chapters).

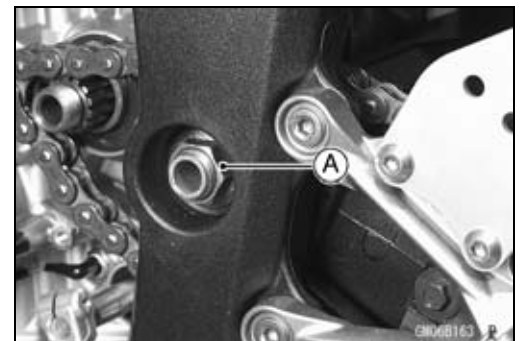

### Swingarm Bearing Removal

- Remove:
  - Swingarm (see Swingarm Removal in this chapter)
  - Washer [A]
  - Oil Seals [B]
  - Sleeve [C]
  - Circlip [D] (Right Side)

**Special Tool - Inside Circlip Pliers: 57001-143**

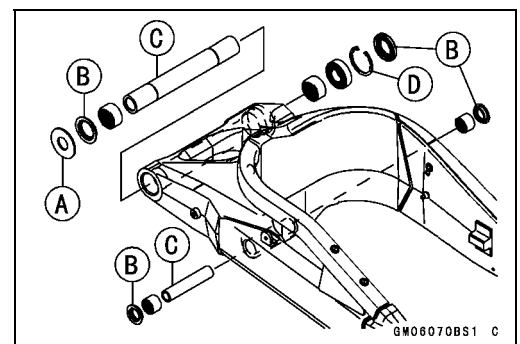

- Remove the ball bearing and needle bearings.

**Special Tool - Oil Seal & Bearing Remover [A]: 57001-1058**

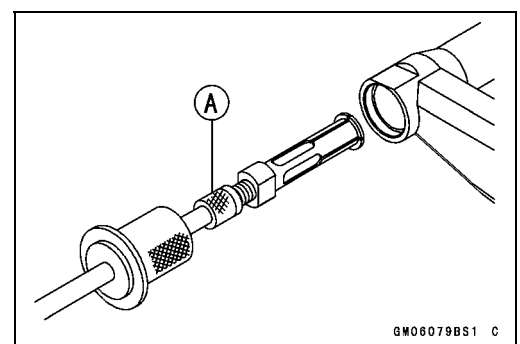

## 13-24 SUSPENSION

### Swingarm

#### Swingarm Bearing Installation

- Replace the ball and needle bearings [A] with new ones.
- Install the ball and needle bearings so that the manufacturer's marks face out.

**Special Tools - Bearing Driver Set: 57001-1129**

**Needle Bearing Driver,  $\phi 28$  [B]: 57001-1610**

**Spacer,  $\phi 28$ : 57001-1637**

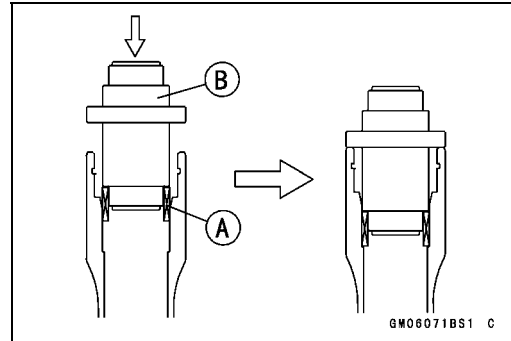

- Install the needle bearings [A], ball bearing [B] and oil seals [C] position as shown.

Circlip [D]

32.5 mm (1.28 in.) [E]

17 mm (0.67 in.) [F]

0.5 mm (0.02 in.) [G]

1 mm (0.04 in.) [H]

5 mm (0.20 in.) [I]

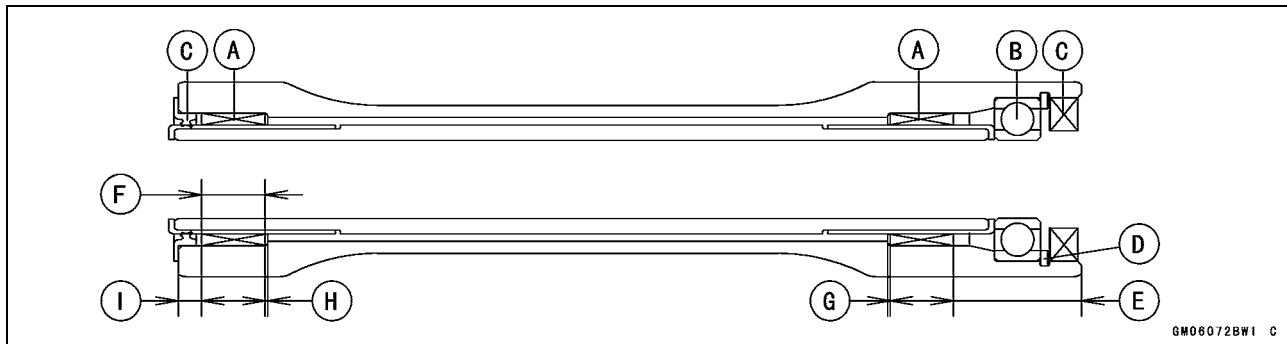

#### Swingarm Bearing, Sleeve Inspection

##### CAUTION

**Do not remove the bearings for inspection. Removal may damage them.**

- Inspect the needle bearings [A] and ball bearing installed in the swingarm.
- The rollers and ball in a bearing normally wear very little, and wear is difficult to measure. Instead of measuring, visually inspect the bearing for abrasion, discoloration, or other damage.
- ★ If the needle bearing and sleeve [B] show any signs of abnormal wear, discoloration, or damage, replace them as a set.

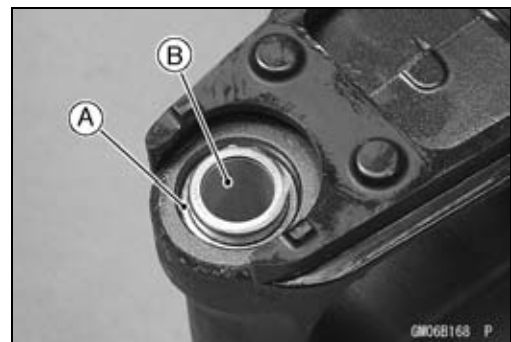

### Swingarm

- Turn the bearing in the coupling back and forth [A] while checking for plays, roughness, or binding.
- ★ If bearing play, roughness, or binding is found, replace the bearing.
- Examine the bearing seal [B] for tears or leakage.
- ★ If the seal is torn or is leaking, replace the bearing.

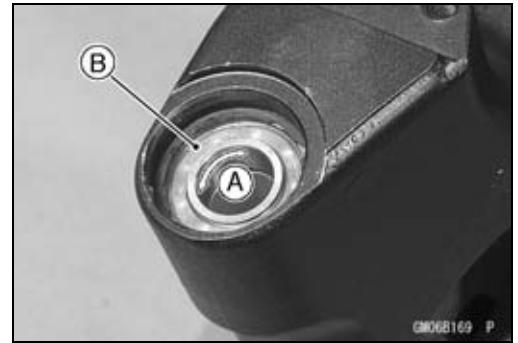

### *Chain Guide Inspection*

- Refer to the Chain Guide Wear Inspection in the Periodic Maintenance chapter.

## 13-26 SUSPENSION

### Tie-Rod, Rocker Arm

#### Tie-Rod Removal

- Remove the lower fairings (see Lower Fairing Removal in the Frame chapter).
- Squeeze the brake lever slowly and hold it with a band [A].

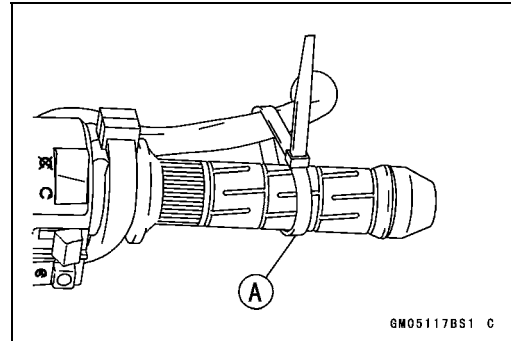

- Using the jack, raise the rear wheel off the ground.

**Special Tools - Jack: 57001-1238**

**Jack Attachment: 57001-1608**

- Remove:
  - Center Pipe (see Muffler Body Removal in the Engine Top End chapter)
  - Upper Tie-Rod Bolt and Nut [A]
  - Lower Tie-Rod Bolt and Nut [B]
  - Tie-Rods [C]

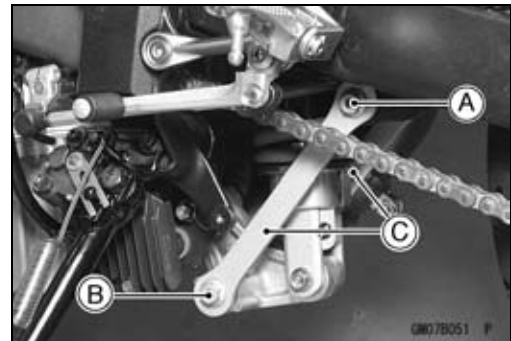

#### Tie-Rod Installation

- Apply grease to the inside of the grease seals.
- Install the tie-rods so that the marked side faces [A] outside.
- Tighten:
  - Torque - Tie-Rod Nuts: 59 N·m (6.0 kgf·m, 43 ft·lb)**



#### Rocker Arm Removal

- Remove:
  - Lower Fairings (see Lower Fairing Removal in the Frame chapter)
  - Regulator/Rectifier [A] (see Regulator/Rectifier Removal in the Electrical System chapter)
- Squeeze the brake lever slowly and hold it with a band.
- Using the jack, raise the rear wheel off the ground.

**Special Tools - Jack: 57001-1238**

**Jack Attachment: 57001-1608**

- Remove:
  - Center Pipe (see Muffler Body Removal in the Engine Top End chapter)
  - Lower Rear Shock Absorber Bolt and Nut [B]
  - Lower Tie-Rod Bolt and Nut [C]
  - Rocker Arm Bolt and Nut [D]
  - Rocker Arm [E]

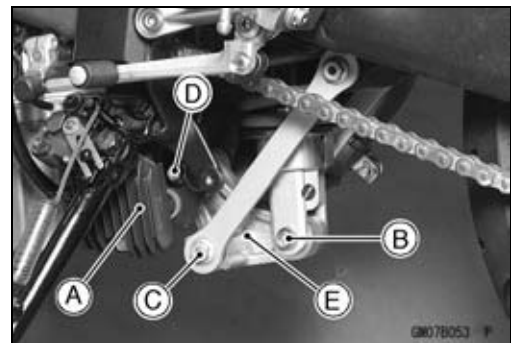

## Tie-Rod, Rocker Arm

### Rocker Arm Installation

- Apply grease to the inside of the grease seals.
- Tighten:
  - Torque - Uni-Trak Rocker Arm Nut: 34 N·m (3.5 kgf·m, 25 ft·lb)**
  - Tie-Rod Nuts: 59 N·m (6.0 kgf·m, 43 ft·lb)**
  - Rear Shock Absorber Nut (Lower): 34 N·m (3.5 kgf·m, 25 ft·lb)**

### Tie-Rod and Rocker Arm Bearing Removal

- Remove:
    - Tie-Rods (see Tie-Rod Removal in this chapter)
    - Rocker Arm (see Rocker Arm Removal in this chapter)
    - Sleeves [A]
    - Oil Seal [B]
    - Swingarm [C]
  - Remove the needle bearings [D], using the bearing remover head and bearing remover shaft.
- Special Tools - Bearing Remover Head,  $\phi 20 \times \phi 22$ : 57001-1293**
- Bearing Remover Shaft,  $\phi 13$ : 57001-1377**

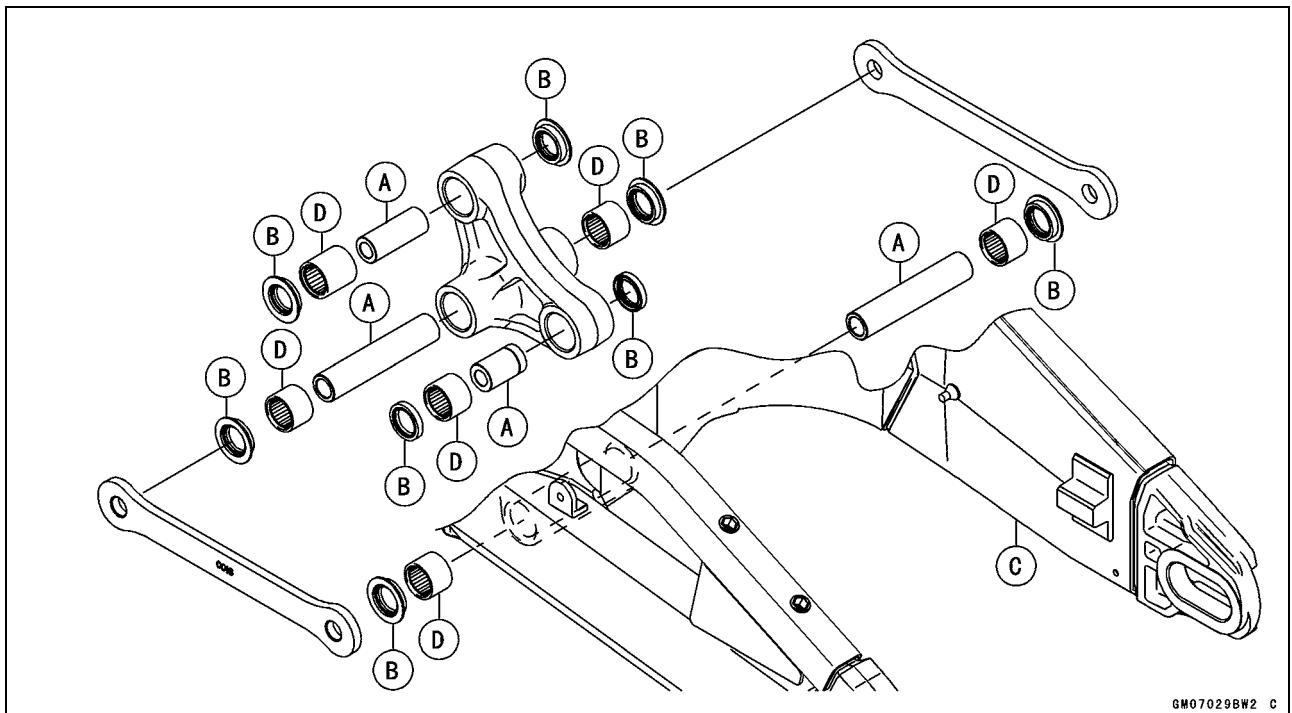

GM07029BW2 C

### Tie-Rod and Rocker Arm Bearing Installation

- Replace the needle bearing and oil seals with new ones.
- Apply plenty of grease to the lips of the oil seals.
- Install the needle bearings and oil seals position as shown.

# 13-28 SUSPENSION

## Tie-Rod, Rocker Arm

- Screw the needle bearing driver [A] into the driver holder [B].
- Insert the needle bearing driver into the needle bearing [C] and press the needle bearing into the housing until the driver contacts the end surface of the housing.  
 Bearing Pressing Depth: 5.5 mm (0.22 in.)[D]  
 5.0 mm (0.20 in.)[E]

**NOTE**

○For a bearing of inner diameter  $\phi 18$ , select the pressing side of the needle bearing driver according to its pressing depth.

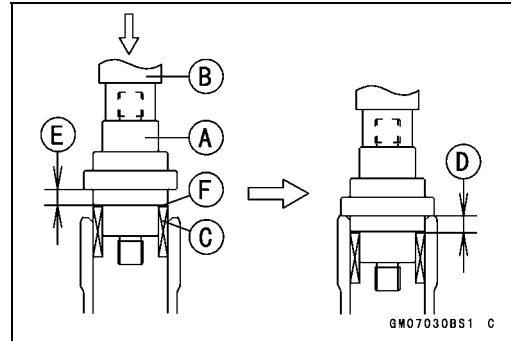

- Special Tools - Bearing Driver Set: 57001-1129**  
**Needle Bearing Driver,  $\phi 17/\phi 18$ : 57001-1609**  
**Spacer,  $\phi 18$  [F]: 57001-1636**

**NOTE**

○Install the needle bearings so that the marked side faces out.

- Needle Bearing [A]
- Oil Seals [B]
- Front [C]
- Right Side [D]
- Left Side [E]
- Rear Shock Absorber [F]
- Tie-Rod [G]
- Rocker Arm [H]
- 7.5 mm (0.30 in.) [I]
- 5.0 mm (0.20 in.) [J]
- 5.5 mm (0.22 in.) [K]

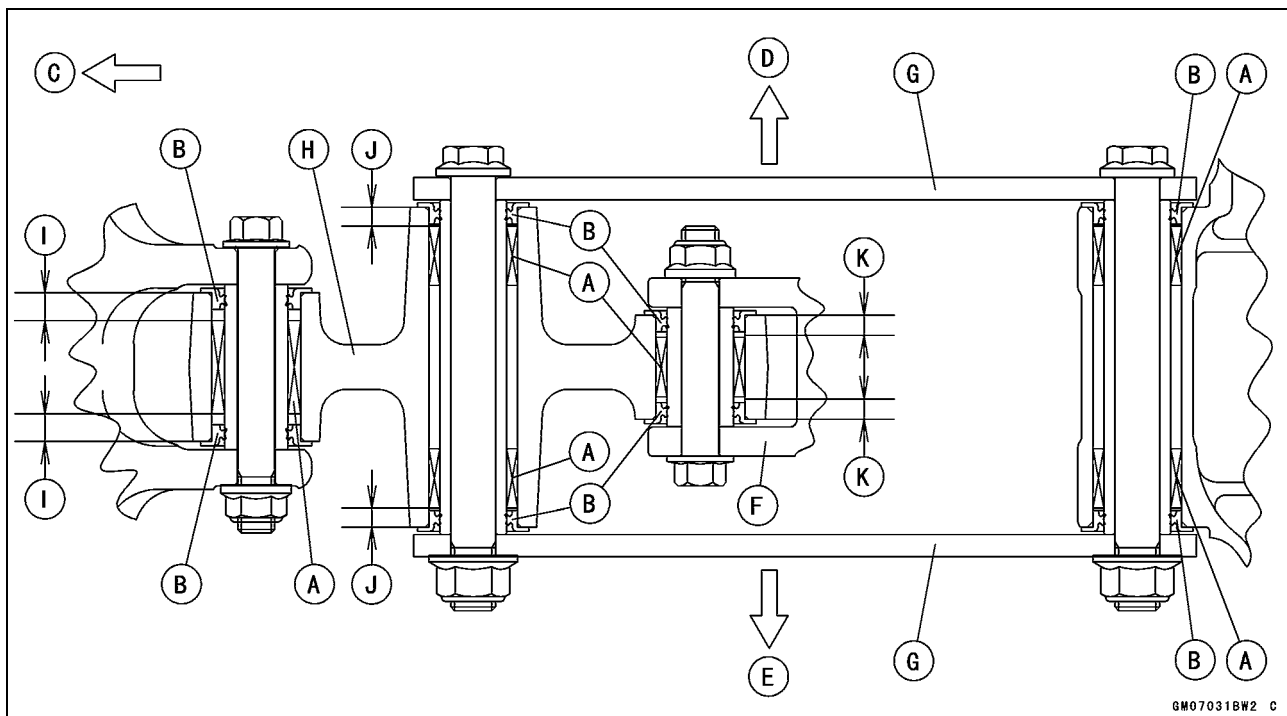

## Tie-Rod, Rocker Arm

### Rocker Arm/Tie-Rod Bearing, Sleeve Inspection

#### CAUTION

**Do not remove the bearings for inspection. Removal may damage them.**

- Visually inspect the locker arm, or tie-rod sleeves [A] and needle bearings [B].
- The rollers in a needle bearing normally wear very little, and wear is difficult to measure. Instead of measuring, inspect the bearing for abrasion, color change, or other damage.
- ★ If there is any doubt as to the condition of any of the needle bearings or sleeve replace the sleeve and needle bearings as a set.

### Rocker Arm/Tie-Rod Bearing Lubrication

#### NOTE

○ Since the bearings are packed with grease, lubrication is not required.

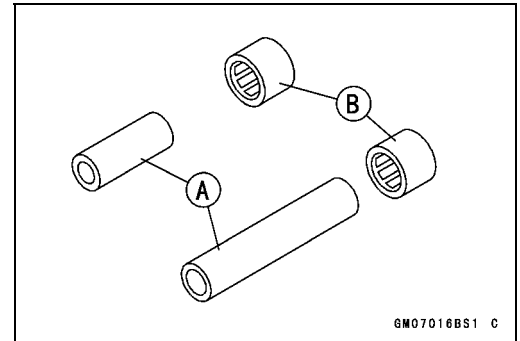



---

---

# Steering

## Table of Contents

Exploded View .....	14-2
Special Tools .....	14-4
Steering .....	14-5
Steering Inspection .....	14-5
Steering Adjustment.....	14-5
Steering Stem.....	14-6
Stem, Stem Bearing Removal.....	14-6
Stem, Stem Bearing Installation.....	14-7
Steering Stem Bearing Lubrication .....	14-9
Steering Stem Warp.....	14-9
Stem Cap Deterioration, Damage.....	14-9
Handlebar .....	14-10
Handlebar Removal .....	14-10
Handlebar Installation .....	14-10

# 14-2 STEERING

## Exploded View

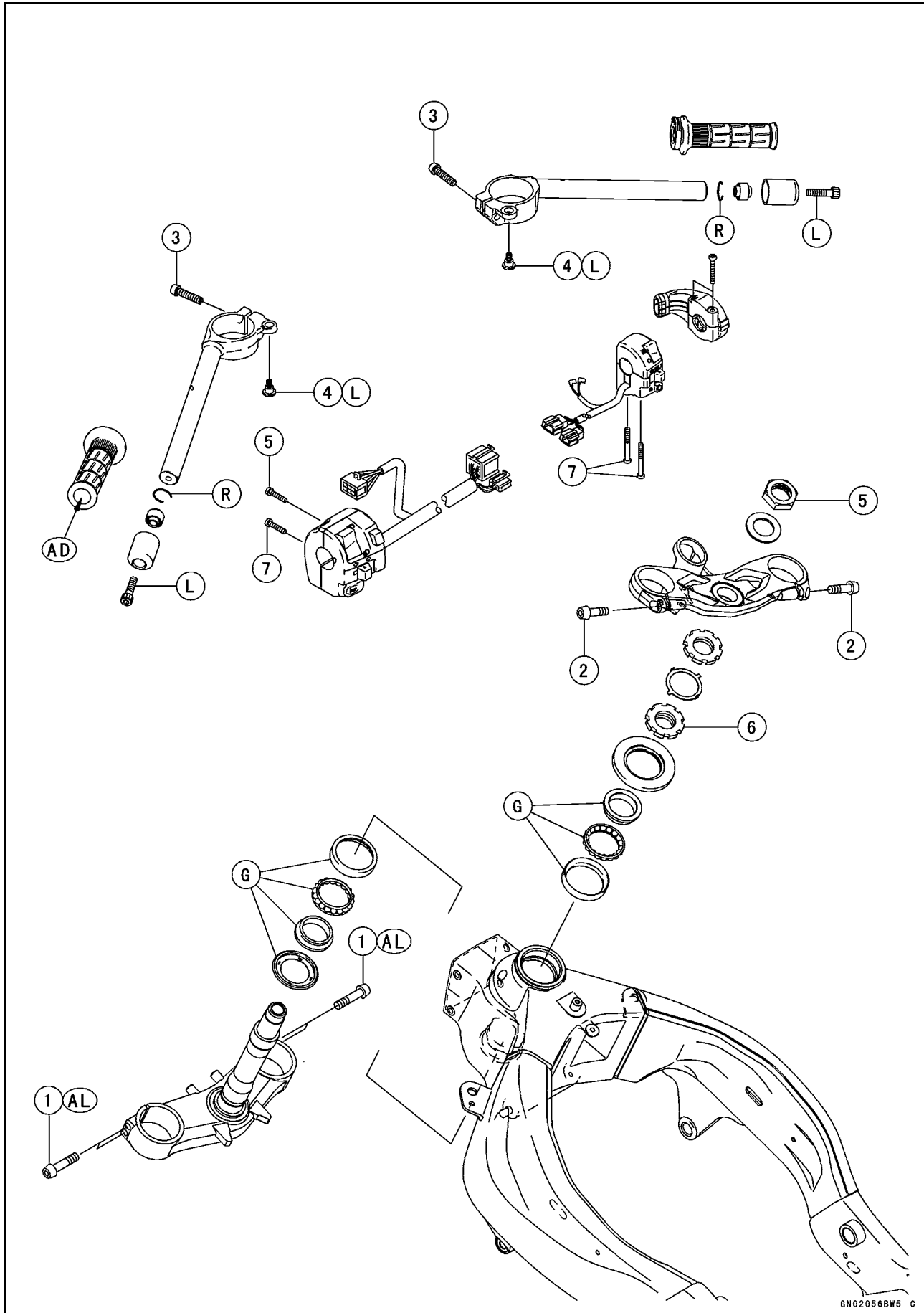

**Exploded View**

No.	Fastener	Torque			Remarks
		N·m	kgf·m	ft·lb	
1	Front Fork Clamp Bolts (Lower)	25	2.5	18	AL
2	Front Fork Clamp Bolts (Upper)	20	2.0	15	
3	Handlebar Bolts	25	2.5	18	
4	Handlebar Position Bolts	9.8	1.0	87 in·lb	L
5	Steering Stem Head Nut	78	8.0	58	
6	Steering Stem Nut	20	2.0	15	
7	Switch Housing Screws	3.5	0.36	31 in·lb	

AD: Apply adhesive.

AL: Tighten the two clamp bolts alternately two times to ensure even tightening torque.

G: Apply grease.

L: Apply a non-permanent locking agent.

R: Replacement Parts

# 14-4 STEERING

## Special Tools

**Bearing Puller Adapter:  
57001-136**

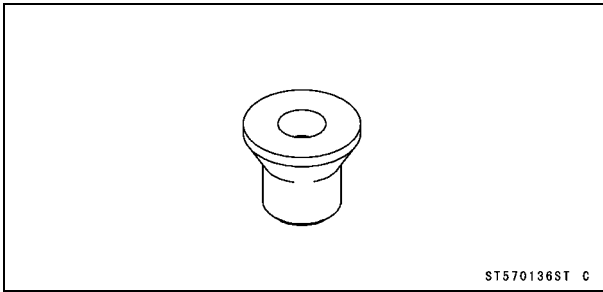

**Bearing Driver Set:  
57001-1129**

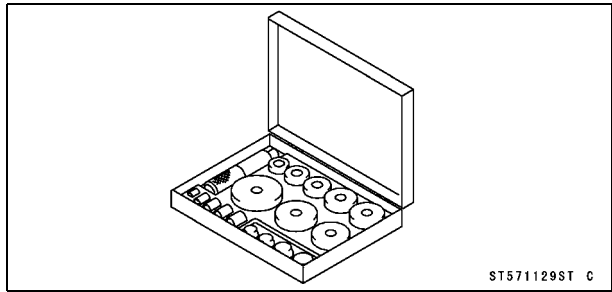

**Bearing Puller:  
57001-158**

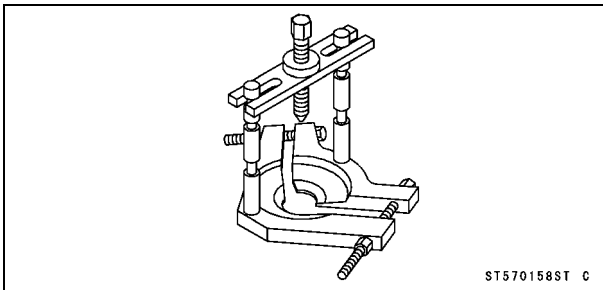

**Steering Stem Bearing Driver,  $\phi 42.5$ :  
57001-1344**

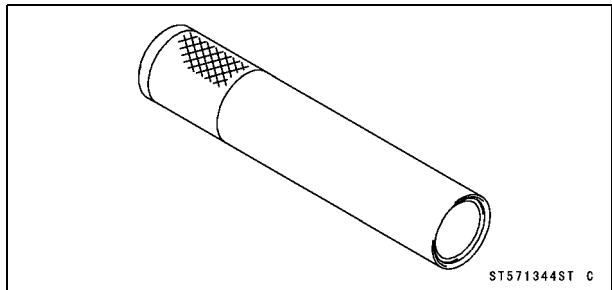

**Head Pipe Outer Race Press Shaft:  
57001-1075**

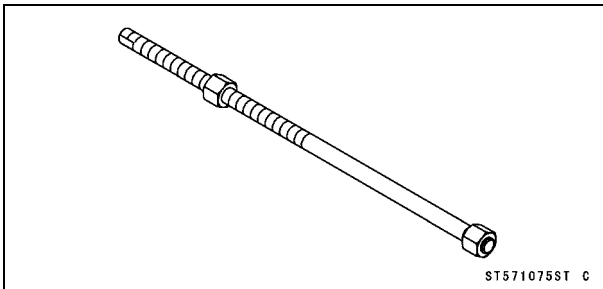

**Steering Stem Bearing Driver Adapter,  $\phi 41.5$ :  
57001-1345**

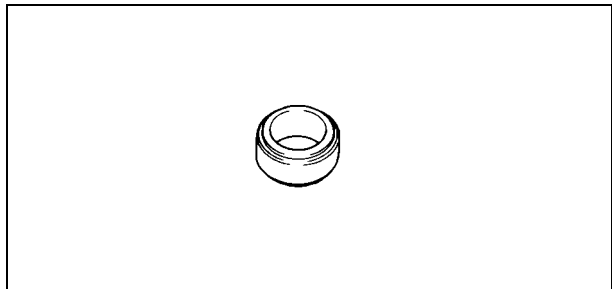

**Steering Stem Nut Wrench:  
57001-1100**

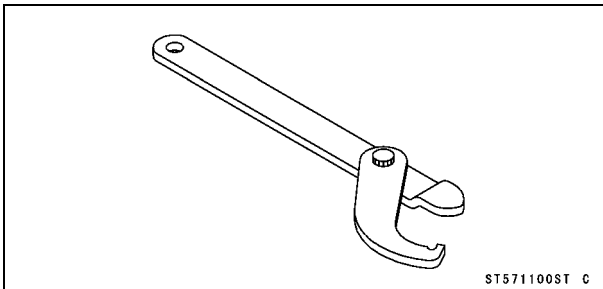

**Head Pipe Outer Race Driver,  $\phi 55$ :  
57001-1446**

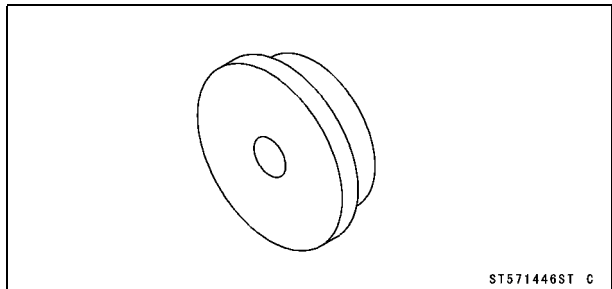

**Steering**

---

*Steering Inspection*

- Refer to the Steering Inspection in the Periodic Maintenance chapter.

*Steering Adjustment*

- Refer to the Steering Adjustment in the Periodic Maintenance chapter.

## 14-6 STEERING

### Steering Stem

#### Stem, Stem Bearing Removal

- Remove:
  - Upper Fairing (see Upper Fairing Removal in the Frame chapter)
  - Front Wheel (see Front Wheel Removal in the Wheels/Tires chapter)
  - Front Fork (see Front Fork Removal in the Suspension chapter)
  - Brake Hose Clamp Bolt [A]



- Remove:
  - Steering Stem Head Nut [A] and Washer [B]
  - Steering Stem Head
  - Handlebars (see Handlebar Removal in this chapter)



- Bend the claws [A] of lock washer straighten.
- Remove the steering stem locknut [B].
  - Special Tool - Steering Stem Nut Wrench: 57001-1100**
- Remove the lock washer.

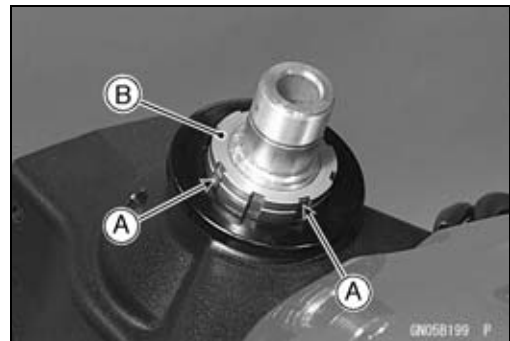

- Pushing up the stem base, and remove the steering stem nut [A] with stem cap.

**Special Tool - Steering Stem Nut Wrench [B]: 57001-1100**

- Remove:
  - Steering Stem [C]
  - Upper Ball Bearing Inner Race

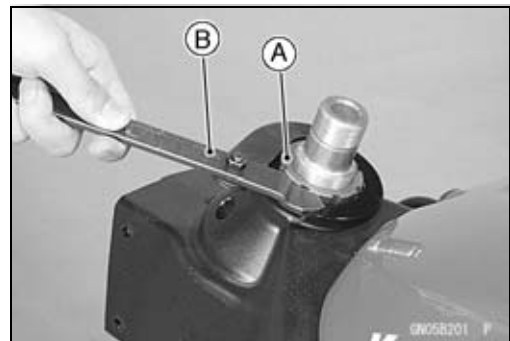

- To remove the bearing outer races [A] pressed into the head pipe [B], insert a bar [C] into the recesses [D] of head pipe, and applying it to both recess alternately hammer it to drive the race out.

#### NOTE

○If either steering stem bearing is damaged, it is recommended that both the upper and lower bearings (including outer races) should be replaced with new ones.

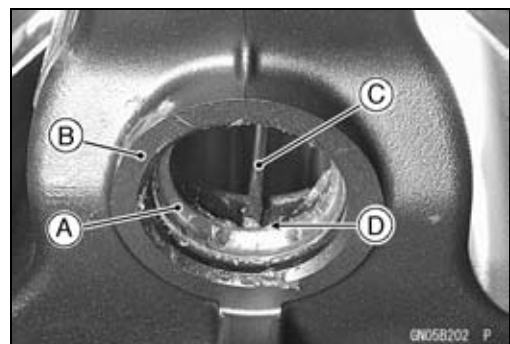

**Steering Stem**

- Remove the lower bearing inner race (with its oil seal) [A] which is pressed onto the steering stem [B] with the bearing puller [C] and adapter [D].

**Special Tools - Bearing Puller Adapter: 57001-136**

**Bearing Puller: 57001-158**

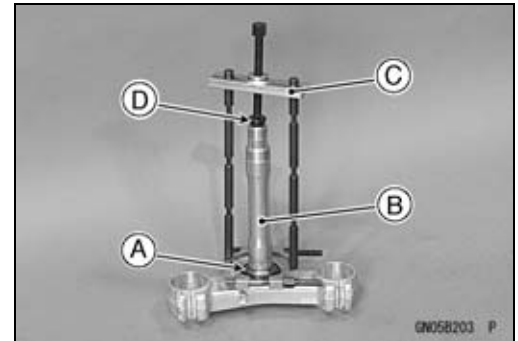

**Stem, Stem Bearing Installation**

- Replace the bearing outer races with new ones.
- Drive them into the head pipe at the same time.

**Special Tools - Head Pipe Outer Race Press Shaft [A]: 57001-1075**

**Bearing Driver Set: 57001-1129**

**Head Pipe Outer Race Driver,  $\phi 55$  [B]: 57001-1446**

- Apply grease to the outer races.

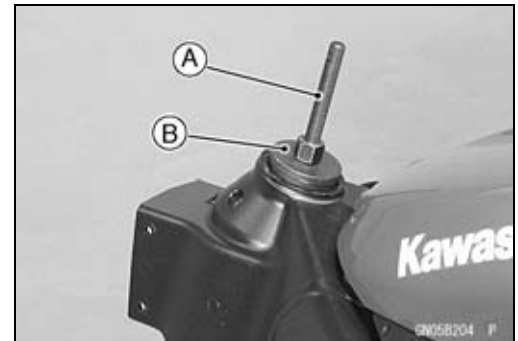

- Replace the bearing inner races and oil seal with new ones.
- Install the oil seal [D] on the steering stem, and drive the lower ball bearing inner race [A] applied the grease onto the stem.

**Special Tools - Steering Stem Bearing Driver,  $\phi 42.5$  [B]: 57001-1344**

**Steering Stem Bearing Driver Adapter,  $\phi 41.5$  [C]: 57001-1345**

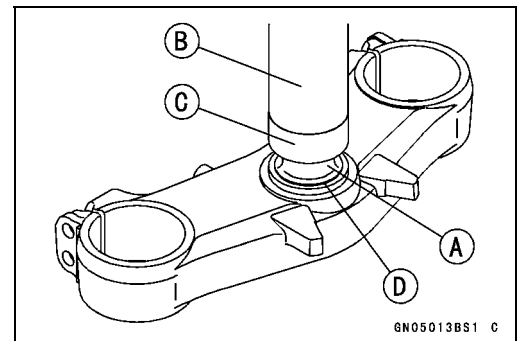

- Install the lower ball bearing [A] onto the stem.
- Apply grease:
  - Inner and Outer Races
  - Lower and Upper Ball Bearings
- The lower and upper ball bearings are identical.



- Install the stem [A] through the head pipe and install the ball bearing [B] and inner race [C] on it.
- Install:
  - Stem Cap [D]
  - Steering Stem Nut [E]

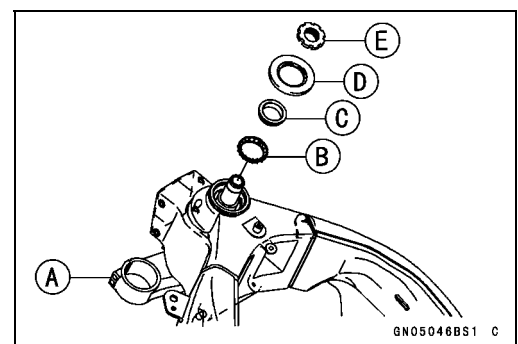

## 14-8 STEERING

### Steering Stem

- Settle the bearings in place as follows.
- Tighten the steering stem nut with **55 N·m (5.6 kgf·m, 41 ft·lb)** of torque first, and loosen it a fraction of a turn until it turns lightly (To tighten the stem nut to the specified torque, hook the wrench on the stem nut, and pull the wrench at the hole by **305 N (31.0 kgf, 69 lb)** [B] force in the direction shown.). Afterward tighten it again with specified torque using a special tool [A].

**Special Tool - Steering Stem Nut Wrench: 57001-1100**

**Torque - Steering Stem Nut: 20 N·m (2.0 kgf·m, 15 ft·lb)**

- For the torque of 20 N·m (2.0 kgf·m, 15 ft·lb), pull the wrench at the hole by 101 N (11.1 kgf, 25 lb) force.
- Install the lock washer [A] so that claw [B] of washer fit the notch [C] of steering stem locknut [D].

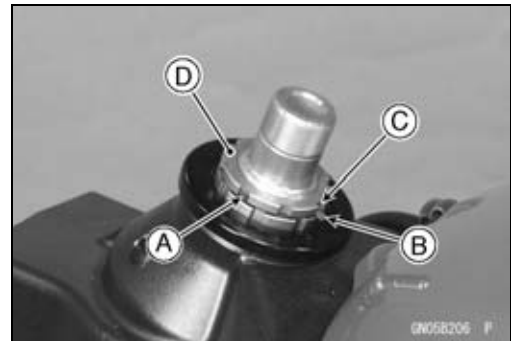
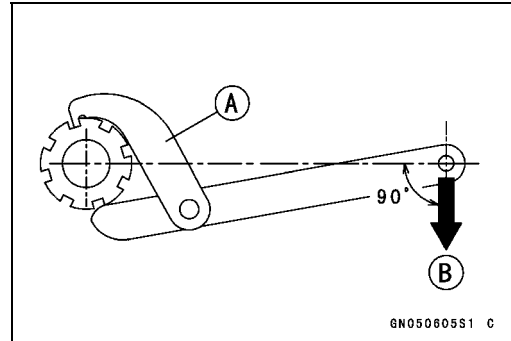

- First tighten the steering stem locknut by hand until the resistance is felt fully, then tighten the steering stem lock nut so that align the claw [A] of stem lock nut to the notch [B] of stem nut by hand.
- Check that there is no play and the steering stem turns smoothly without rattles. If not, the steering stem bearing may be damaged.
- Bend the claw of lock washer [C] to steering stem nut notch.

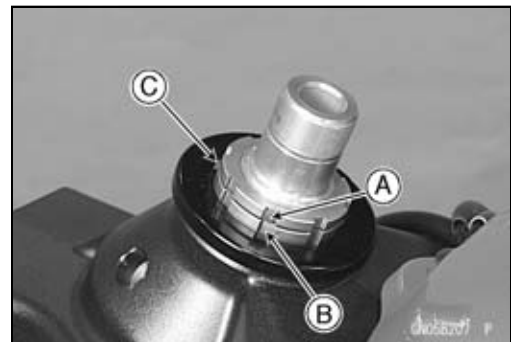

- Install the stem head [A] with handlebars to the steering stem [B].
- Install the washer, and temporary tighten the stem head nut [C].
- Install the front fork (see Front Fork Installation in the Suspension chapter).

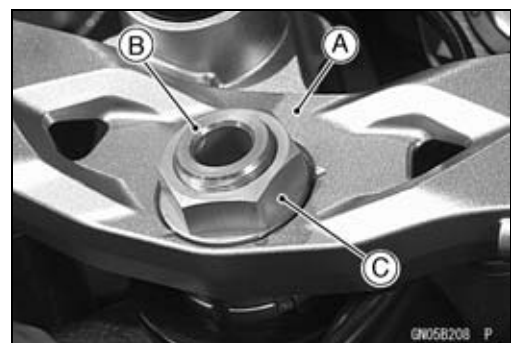

## Steering Stem

### NOTE

- Tighten the upper fork clamp bolts [A] first, next the stem head nut [B], last the lower fork clamp bolts [C] and the handlebar bolts [D].
- Tighten the two lower fork clamp bolts alternately two times to ensure even tightening torque.

**Torque - Front Fork Clamp Bolts (Upper):** 20 N·m (2.0 kgf·m, 15 ft·lb)

**Steering Stem Head Nut:** 78 N·m (8.0 kgf·m, 58 ft·lb)

**Front Fork Clamp Bolts (Lower):** 25 N·m (2.5 kgf·m, 18 ft·lb)

**Handlebar Bolts:** 25 N·m (2.5 kgf·m, 18 ft·lb)

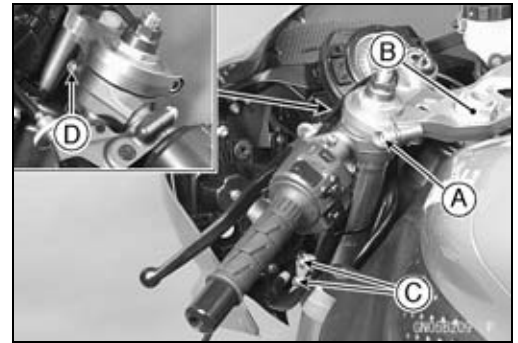

### ⚠ WARNING

Do not impede the handlebar turning by routing the cables, harnesses and hoses improperly (see Cable, Wire, and Hose Routing section in the Appendix chapter).

### Steering Stem Bearing Lubrication

- Refer to the Steering Stem Bearing Lubrication in the Periodic Maintenance chapter.

### Steering Stem Warp

- Whenever the steering stem is removed, or if the steering can not be adjusted for smooth action, check the steering stem for straightness.
- ★ If the steering stem [A] is bent, replace the steering stem.

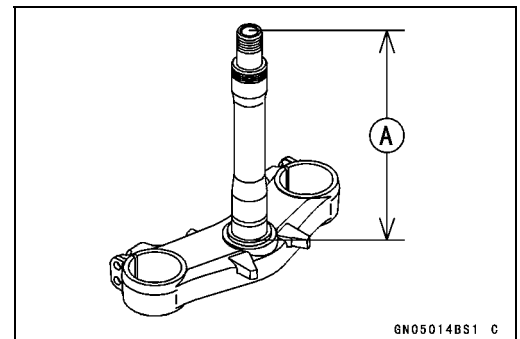

6N05014BS1 C

### Stem Cap Deterioration, Damage

- ★ Replace the stem cap if its oil seal [A] shows damage.



0N06210 F

## 14-10 STEERING

### Handlebar

#### Handlebar Removal

- Remove:
  - Clutch Lever Clamp Bolts [A]
  - Clutch Lever Assembly [B]
  - Left Switch Housing [C]
  - Handlebar Weight [D]
  
- Remove:
  - Front Brake Master Cylinder [A] (see Front Master Cylinder Removal in the Brakes chapter)
  - Right Switch Housing [B]
  - Throttle Case [C]
  - Handlebar Weight [D]
  - Throttle Grip [E]
  
- Loosen:
  - Front Fork Clamp Bolts [A]
  - Handlebar Bolts [B]
- Remove:
  - Steering Stem Head Nut
  - Steering Stem Head with Handlebars [C]
  
- Remove:
  - Handlebar Position Bolts [A]
- Remove the handlebars [B].
- Remove the left handlebar grip.

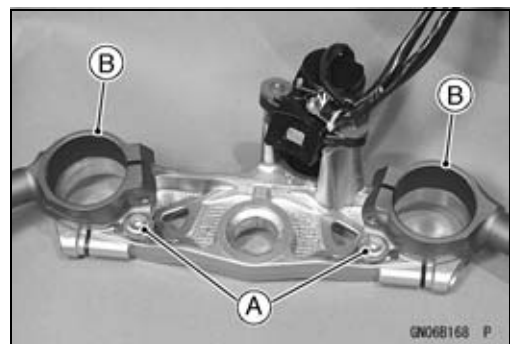
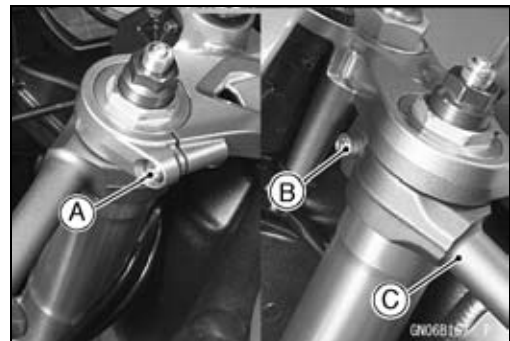
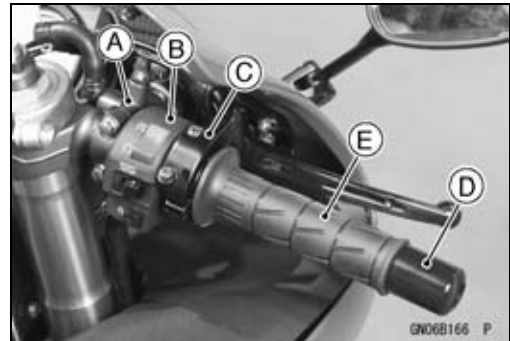
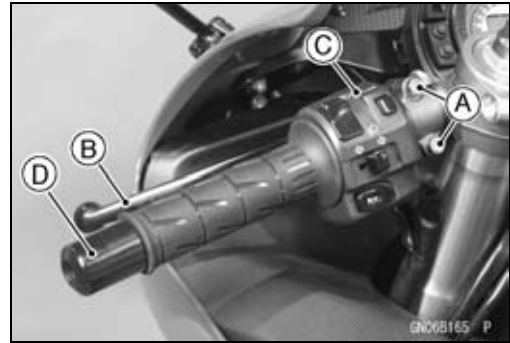

#### Handlebar Installation

- Apply adhesive cement to the inside of the left handlebar grip.
- Apply a non-permanent locking agent to the threads of handlebar position bolts.
- Tighten:
  - Torque - Handlebar Bolts: 25 N·m (2.5 kgf·m, 18 ft·lb)**
  - Handlebar Position Bolts: 9.8 N·m (1.0 kgf·m, 87 in·lb)**
- Install the front brake master cylinder (see Front Master Cylinder Installation in the Brakes chapter).

## Handlebar

- Install the left and right switch housings.
- Fit the projection [A] into a small hole [B] in the handlebar.

**Torque - Switch Housing Screws: 3.5 N·m (0.36 kgf·m, 31 in·lb)**

- Install:
  - Clutch Lever (see Clutch Lever Installation in the Clutch chapter)

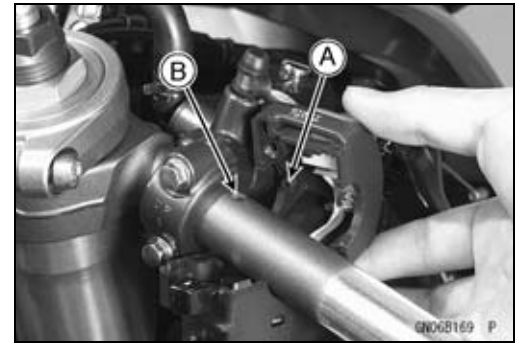

- Install:
  - Throttle Grip
  - Throttle Cable Tips
  - Throttle Cases
- Fit the projection [A] into a small hole [B] in the handlebar.

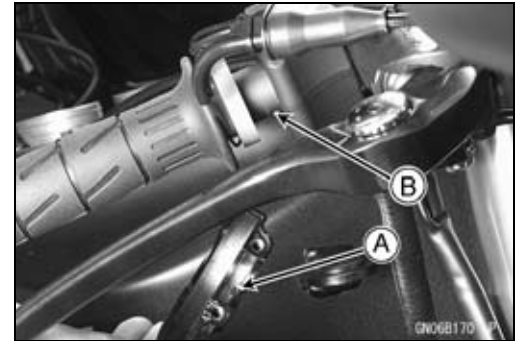

- Apply a non-permanent locking agent to the threads of handlebar weight bolts, and tighten them.
- Install the removed parts (see appropriate chapters).



# Frame

## Table of Contents

Exploded View .....	15-2
Seats .....	15-8
Rear Seat Removal.....	15-8
Rear Seat Installation.....	15-8
Front Seat Removal .....	15-8
Front Seat Installation .....	15-8
Fairings.....	15-9
Lower Fairing Removal .....	15-9
Lower Fairing Installation .....	15-9
Center Fairing Removal .....	15-9
Center Fairing Installation .....	15-10
Windshield Removal .....	15-10
Windshield Installation .....	15-10
Upper Fairing Removal .....	15-10
Upper Fairing Disassembly.....	15-11
Upper Fairing Assembly.....	15-11
Upper Fairing Installation .....	15-12
Upper Inner Fairing Removal.....	15-12
Upper Inner Fairing Installation.....	15-12
Center Inner Fairing Removal.....	15-12
Center Inner Fairing Installation.....	15-12
Right and Left Inner Fairing Removal .....	15-13
Right and Left Inner Fairing Installation .....	15-13
Side Covers.....	15-14
Left Side Cover Removal .....	15-14
Left Side Cover Installation .....	15-14
Right Side Cover Removal.....	15-14
Right Side Cover Installation.....	15-14
Seat Cover.....	15-15
Seat Cover Removal.....	15-15
Seat Cover Installation .....	15-15
Fenders .....	15-16
Front Fender Removal .....	15-16
Front Fender Installation .....	15-16
Flap and Rear Fender Rear Removal.....	15-16
Flap and Rear Fender Rear Installation.....	15-17
Rear Fender Front Removal .....	15-18
Rear Fender Front Installation .....	15-18
Frame .....	15-19
Rear Frame Removal.....	15-19
Rear Frame Installation.....	15-19
Frame Inspection .....	15-19
Side Stand .....	15-20
Side Stand Removal .....	15-20
Side Stand Installation .....	15-20

# 15-2 FRAME

## Exploded View

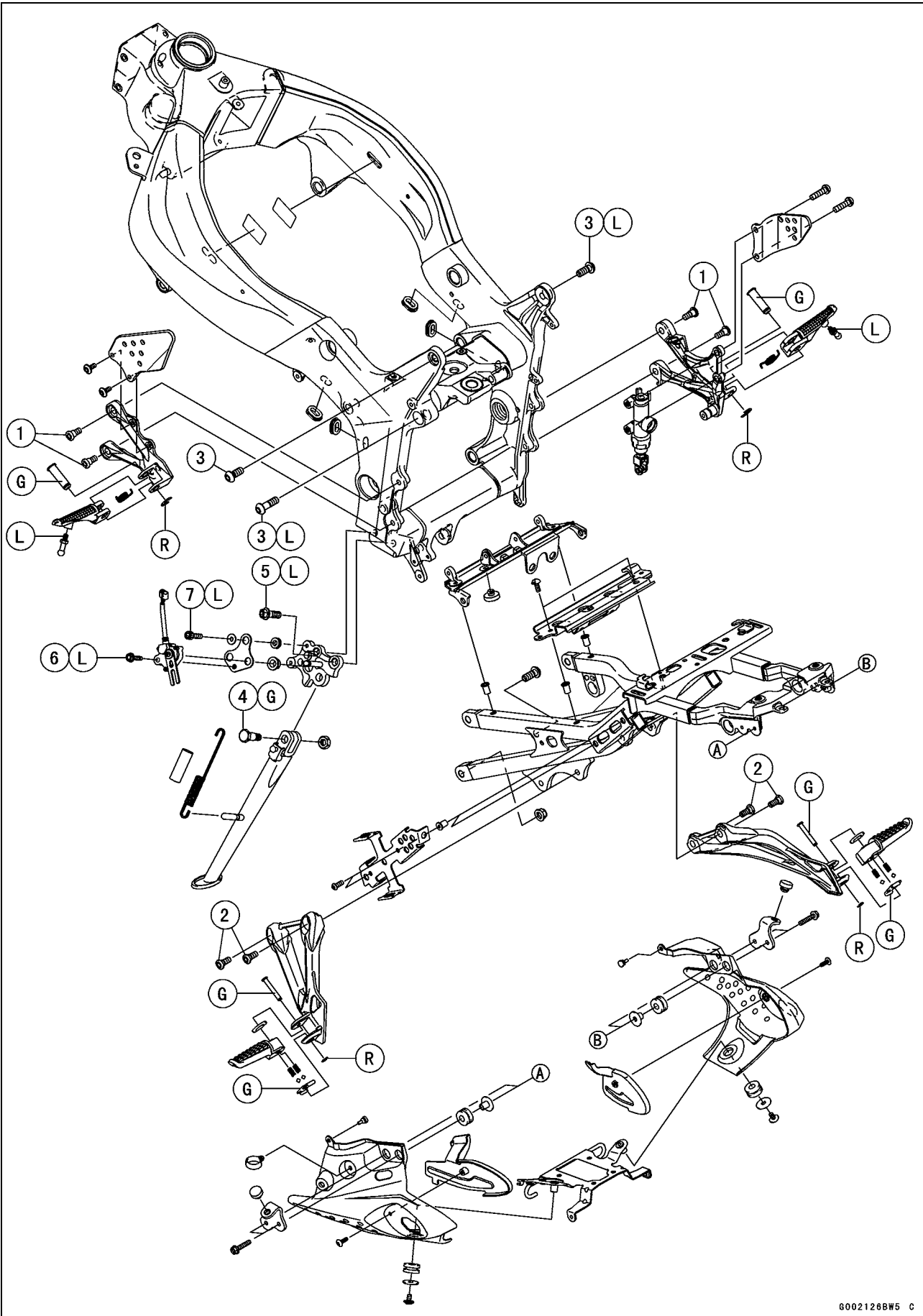

**Exploded View**

No.	Fastener	Torque			Remarks
		N·m	kgf·m	ft·lb	
1	Front Footpeg Bracket Bolts	25	2.5	18	
2	Rear Footpeg Bracket Bolts	25	2.5	18	
3	Rear Frame Bolts	59	6.0	44	L (2)
4	Side Stand Bolt	44	4.5	32	G
5	Side Stand Bracket Bolts	49	5.0	36	L
6	Side Stand Switch Bolt	8.8	0.90	78 in·lb	L
7	Side Stand Switch Bracket Bolt	3.9	0.40	35	L

G: Apply grease.

L: Apply a non-permanent locking agent.

R: Replacement Parts

# 15-4 FRAME

## Exploded View

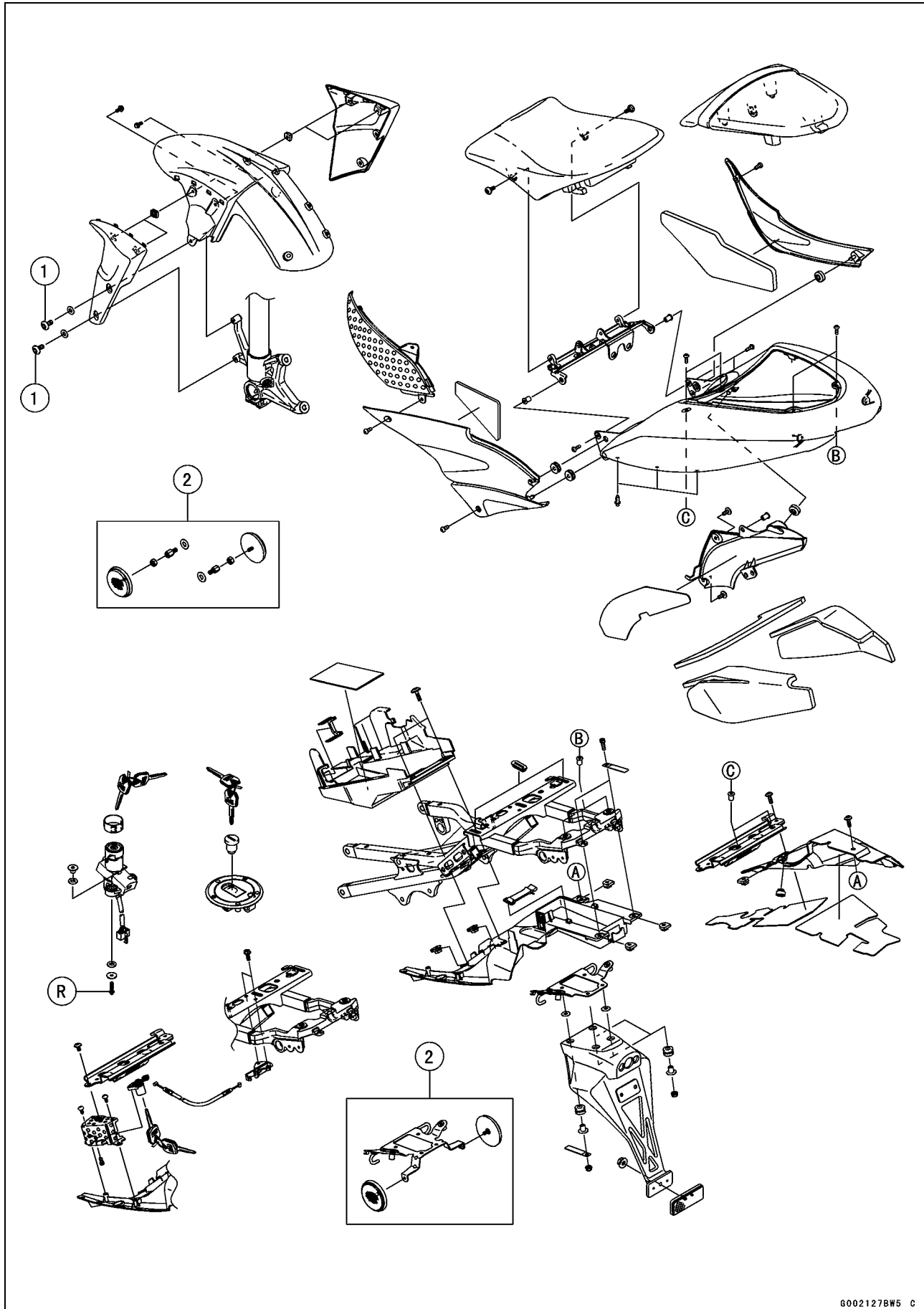

**Exploded View**

No.	Fastener	Torque			Remarks
		N·m	kgf·m	ft·lb	
1	Front Fender Mounting Bolts	3.9	0.40	35 in·lb	

2. United States and Canada Models  
R: Replacement Parts

# 15-6 FRAME

## Exploded View

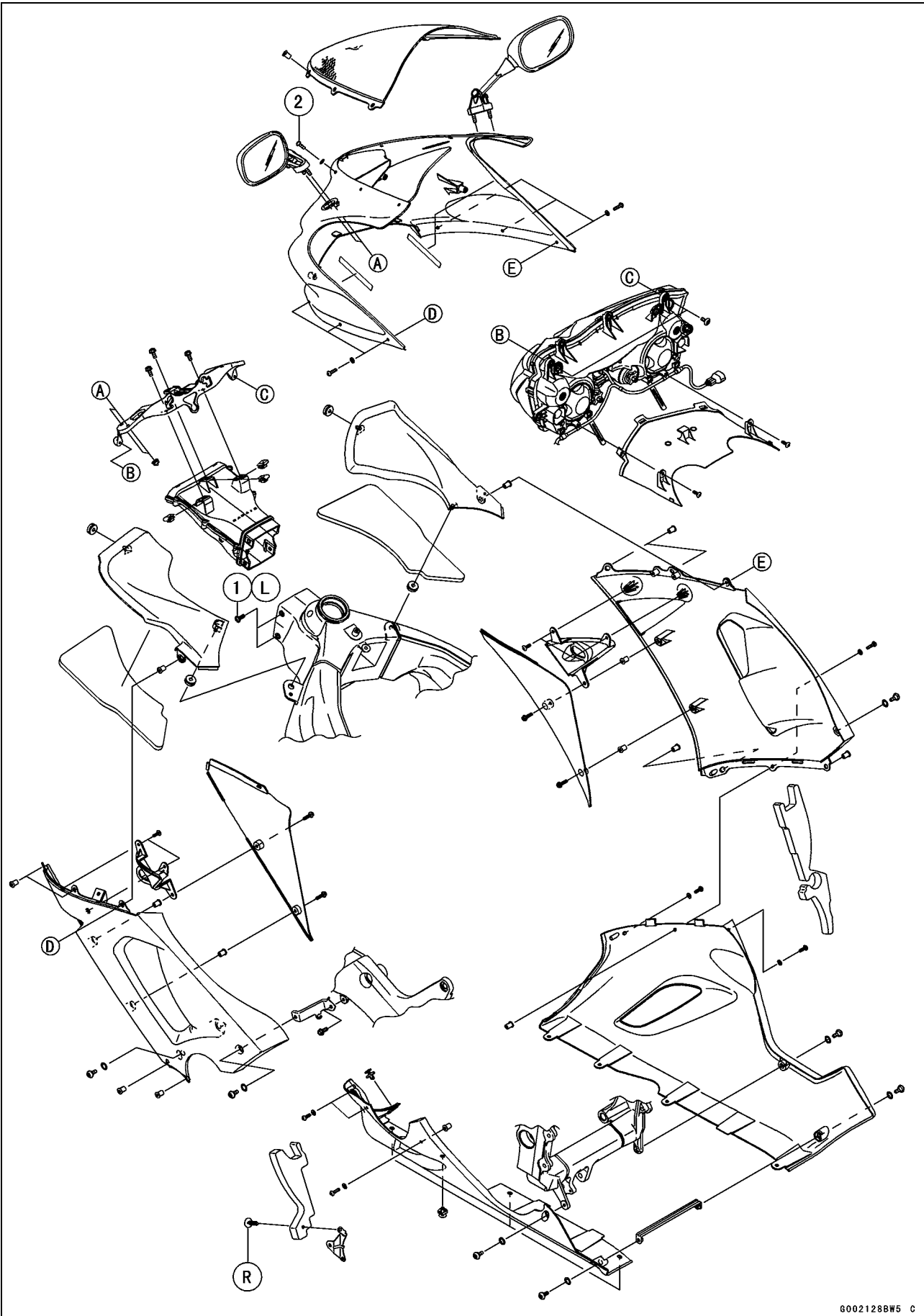

**Exploded View**

No.	Fastener	Torque			Remarks
		N·m	kgf·m	ft·lb	
1	Air Inlet Duct Mounting Bolts	6.9	0.70	61	L
2	Windshield Mounting Bolts	0.4	0.04	4 in·lb	

L: Apply a non-permanent locking agent.

R: Replacement Parts

## 15-8 FRAME

### Seats

#### Rear Seat Removal

- Insert the ignition switch key [A] into the seat lock, turning the key counterclockwise, pulling the front part of the seat [B] up, and pull the seat forward.

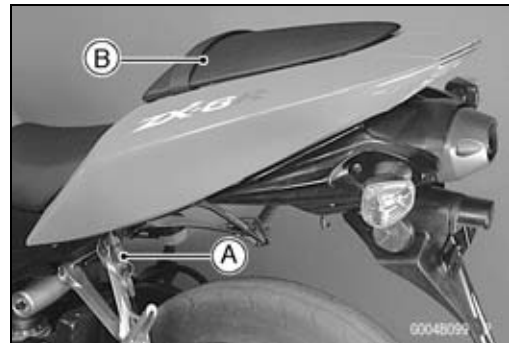

#### Rear Seat Installation

- Put the rear seat hook [A] on the rib [B].
- Insert the seat pins [C] into the latch holes [D].



#### Front Seat Removal

- Remove:
  - Side Covers (Both Side) (see Right/Left Side Cover Removal in this chapter)
  - Mounting Bolts [A] (Both Side)
- Remove the front seat by pulling the front of it up and forward.

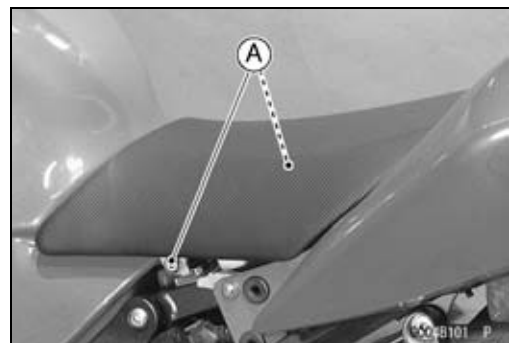

#### Front Seat Installation

- Slip the front seat hooks [A] under the brace [B] of the bracket.
- Tighten the mounting bolts.

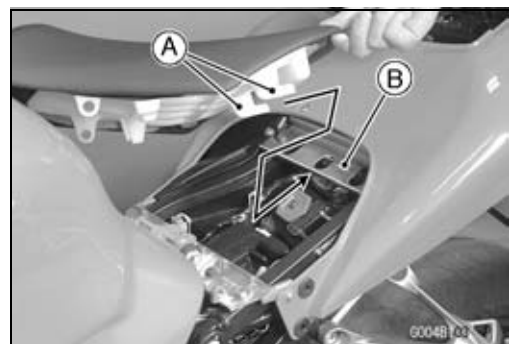

## Fairings

### Lower Fairing Removal

- Remove:
  - Bolts [A] with Washers
  - Clear the hook portion from the slot.

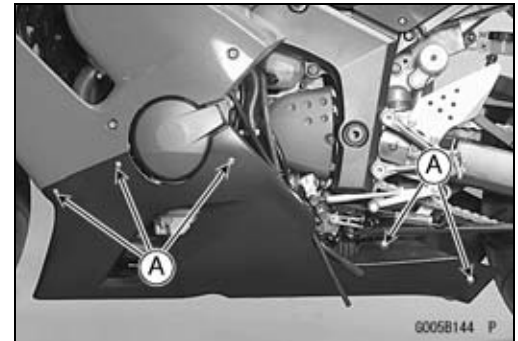

- Pull up the core [A] by the thin blade driver.
- Remove:
  - Quick Rivets [B]
- Separate the right lower fairing from the left lower fairing.

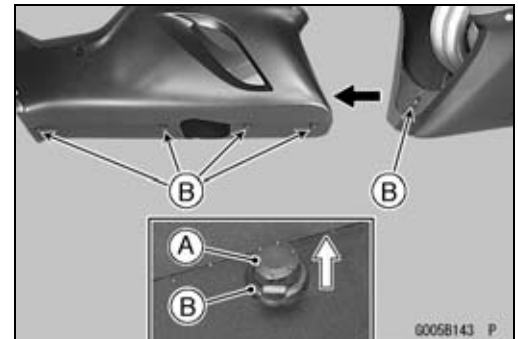

### Lower Fairing Installation

- Set the quick rivet [A] and push the core [B].

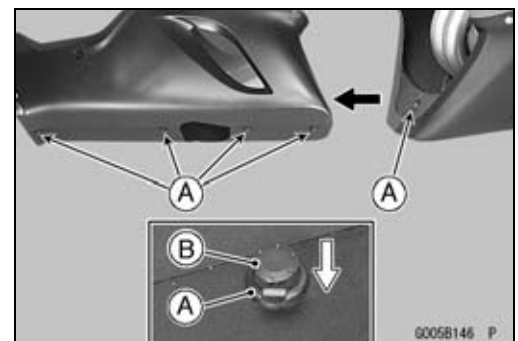

- Insert the hook portion [A] into the slot [B].

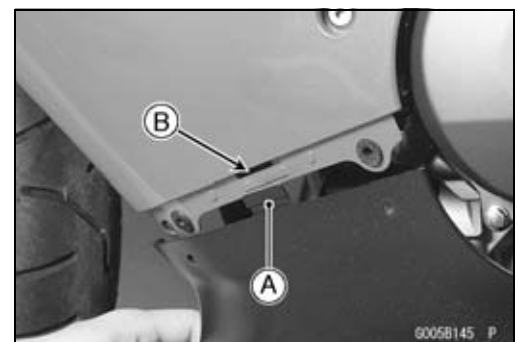

### Center Fairing Removal

- Remove:
  - Lower Fairings (see Lower Fairing Removal in this chapter)
  - Bolts [A] with Washers
  - Left Turn Signal Lead Connector
- Remove the separator bracket bolt from left center fairing (California Model).
- Remove the left center fairing.

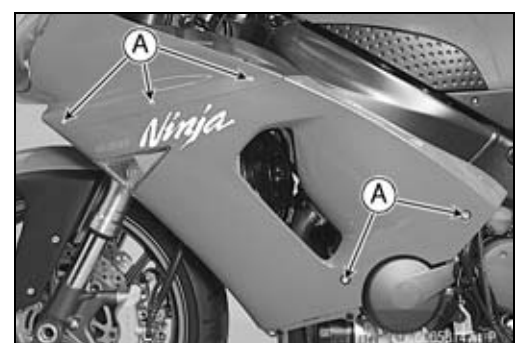

## 15-10 FRAME

### Fairings

- Remove:
  - Right Turn Signal Lead Connector [A]
  - Immobilizer Amplifier Connector [B] (Immobilizer Models)

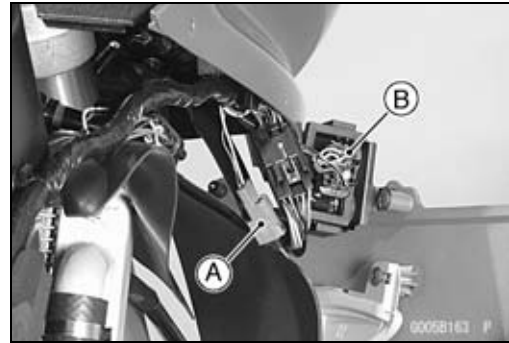

#### Center Fairing Installation

- Install the separator bracket bolt (California Model).
- Connect the immobilizer amplifier connector (Immobilizer Models).
- Connect the turn signal lead connectors.
- Insert the hook [A] into the slot [B].
- Install the washers and bolts.

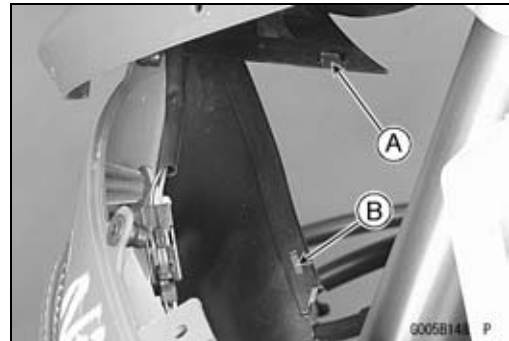

#### Windshield Removal

- Remove:
  - Bolts [A] and Washers
  - Windshield [B]

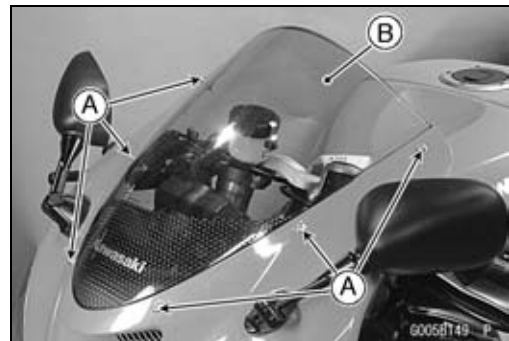

#### Windshield Installation

- Put the front tongue [A] into the hollow [B].
  - Torque - Windshield Mounting Bolts: 0.4 N·m (0.04 kgf·m, 4 in·lb)**

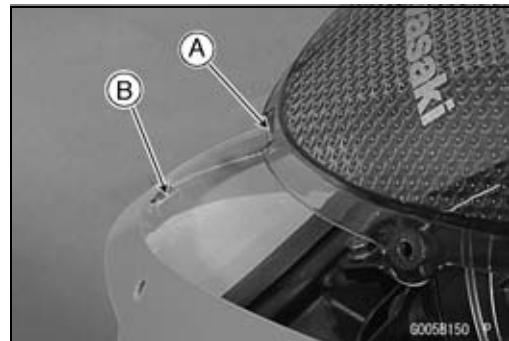

#### Upper Fairing Removal

- Remove:
  - Lower Fairings (see Lower Fairing Removal in this chapter)
  - Center Fairings (see Center Fairing Removal in this chapter)
  - Windshield (see Windshield Removal in this chapter)
  - Upper Inner Fairing (see Upper Inner Fairing Removal in this chapter)
  - Headlight Lead Connector [A]



## Fairings

- Open the clamps [A] (Both Side).

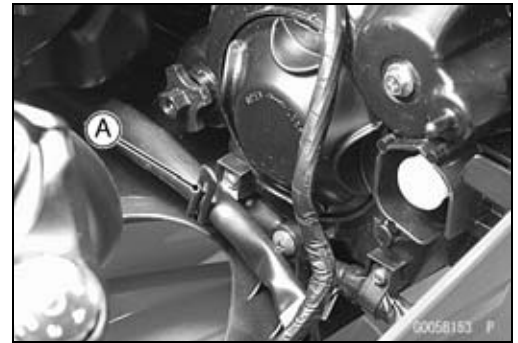

- Disconnect the meter lead connector [A].

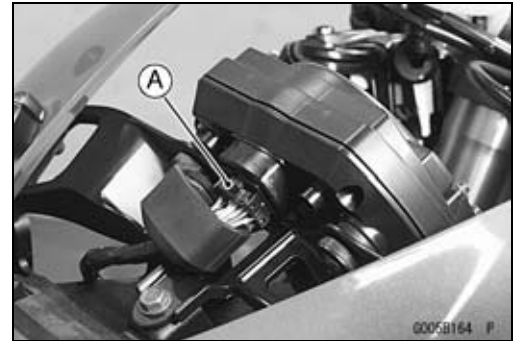

- Remove:
  - Bolts [A] (Both Side)
  - Upper Fairing
- Pull out the upper fairing forward.



### Upper Fairing Disassembly

- Remove:
  - Center Inner Fairing (see Center Inner Fairing Removal in this chapter)
  - Nuts [A] and Rear View Mirrors (Both Side)
  - Meter Unit (see Meter Unit Removal in the Electrical System chapter)
  - Headlight (see Headlight Removal in the Electrical System chapter)
- Pull out the air inlet duct [B] from the upper fairing.

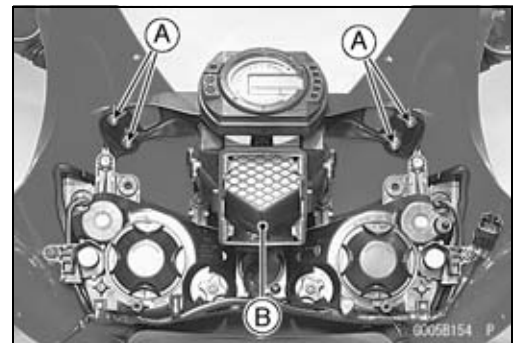

### Upper Fairing Assembly

- Install the air inlet duct [A] in the upper fairing.
- Install the removed parts (see appropriate chapters).



## 15-12 FRAME

### Fairings

#### Upper Fairing Installation

- Fit the opening [A] of the upper fairing into the ram air duct [B].
- Apply a non-permanent locking agent to the threads and, tighten the bolts.

**Torque - Air Inlet Duct Mounting Bolts: 6.9 N·m (0.70 kgf·m, 61 in·lb)**

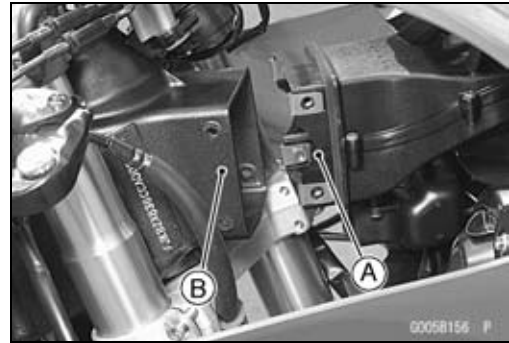

#### Upper Inner Fairing Removal

- Remove the bolt [A].
- Remove the upper inner fairing.
- Remove the upper inner fairing by pulling rear of it up and upward, clear the fairing from the stopper.
- Remove the upper inner fairing by sliding front of it up and backward.



#### Upper Inner Fairing Installation

- Fit the hole [A] of the upper fairing on to the projection [B] of the upper inner fairing.
- Tighten the bolt.

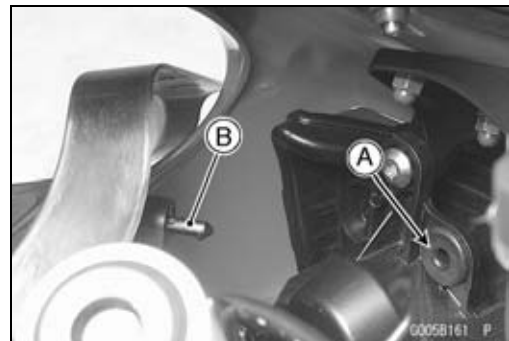

#### Center Inner Fairing Removal

- Remove:
  - Upper Fairing (see Upper Fairing Removal in this chapter)
  - Screws [A]
  - Center Inner Fairing [B]
- Slide out the center inner fairing backward.

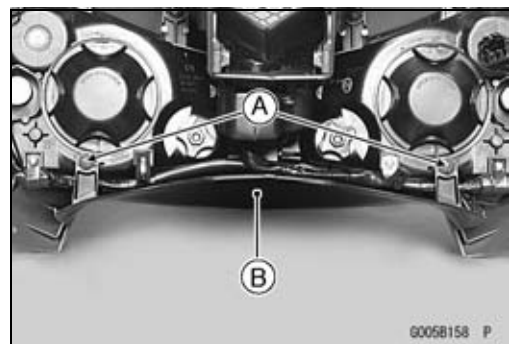

#### Center Inner Fairing Installation

- Insert the holes [A] of the center inner fairing into the tangs [B] of the upper fairing.

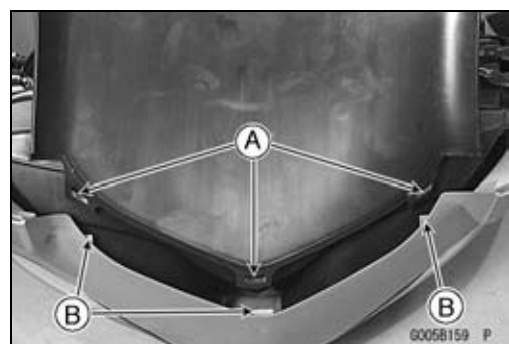

## Fairings

### *Right and Left Inner Fairing Removal*

- Remove:
  - Right and Left Center Fairings (see Center Fairing Removal in this chapter)
  - Bolts [A]
  - Inner Fairing [B]

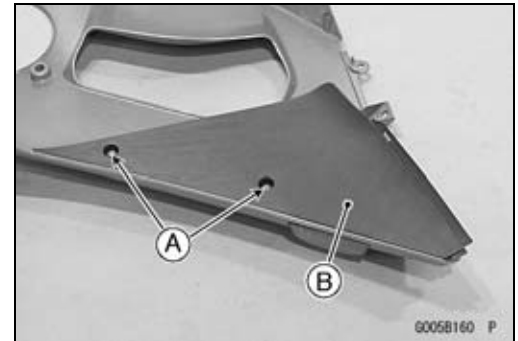

### *Right and Left Inner Fairing Installation*

- Tighten the bolts [A].

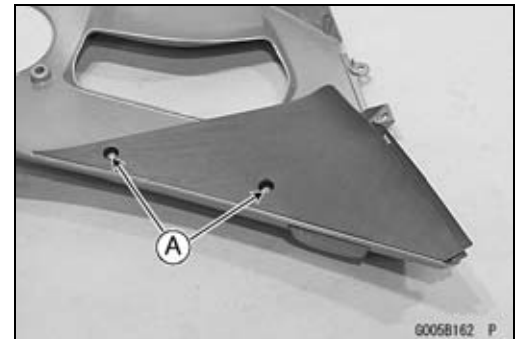

## 15-14 FRAME

### Side Covers

#### *Left Side Cover Removal*

- Remove:
  - Bolts [A]
- Pull out the side cover [B].

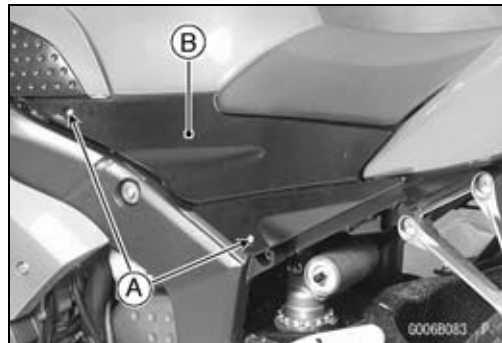

#### *Left Side Cover Installation*

- Insert the projections [A] into the holes [B].

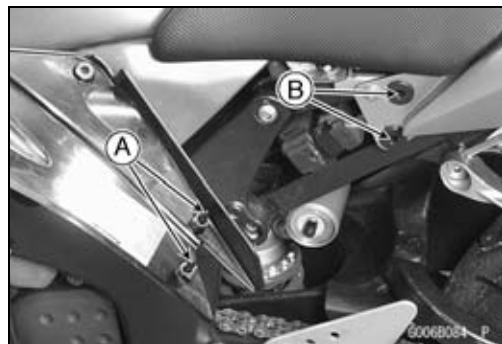

#### *Right Side Cover Removal*

- Remove:
  - Bolt [A]
- Pull out the side cover [B].

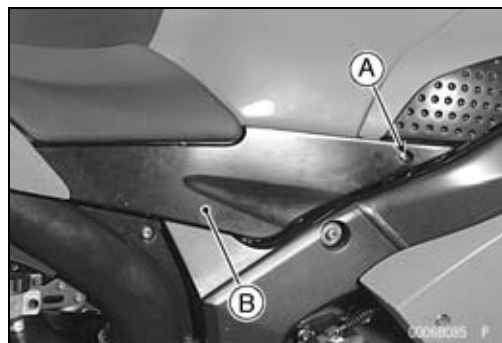

#### *Right Side Cover Installation*

- Insert the projection [A] into the hole [B].

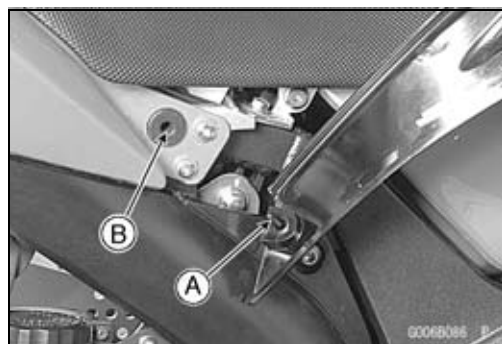

## Seat Cover

### Seat Cover Removal

- Remove:
  - Seats (see Rear/Front Seat Removal in this chapter)
  - Bolts [A]

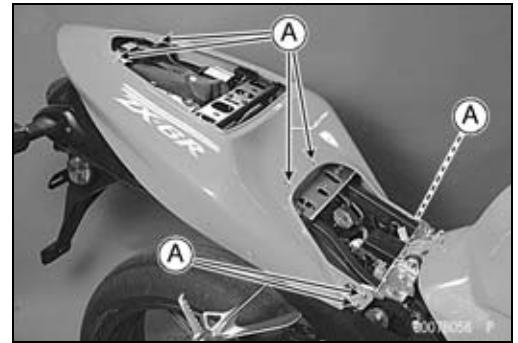

- Remove:
  - Rivet Screws [A]
- Pull the seat cover backward, and clear the stoppers.

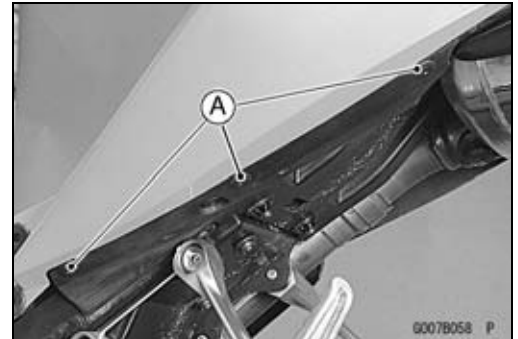

- Disconnect:
  - Tail/Brake Light Connector [A]

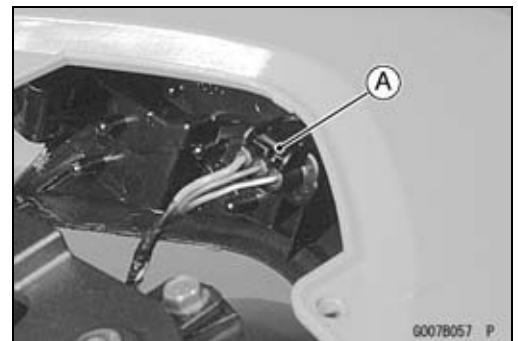

- Remove:
  - Bolts [A]
  - Tail/Brake Light [B]

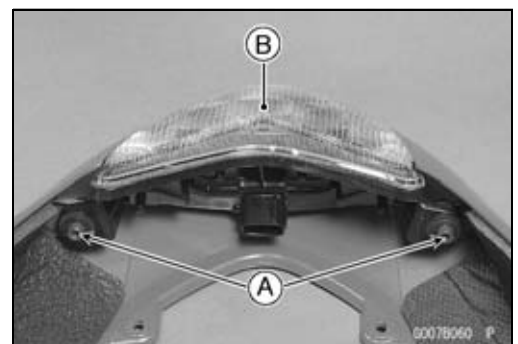

### Seat Cover Installation

- Install the tail/brake light.
- Insert the projections [A] into the holes [B].
- Connect the tail/brake light connector.
- Install:
  - Bolts
  - Rivet Screws

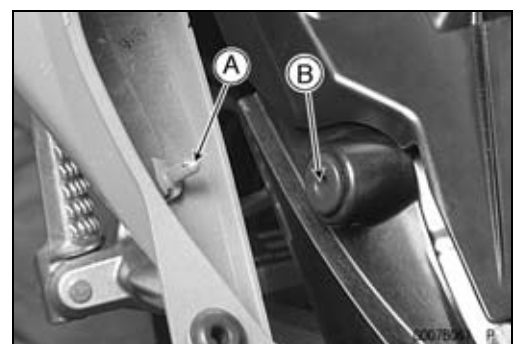

## 15-16 FRAME

### Fenders

#### Front Fender Removal

- Remove:
  - Brake Hose Clamps [A] (Both Side)
  - Bolts [B] with Washer (Both Side)
- Remove the front fender assy [C].

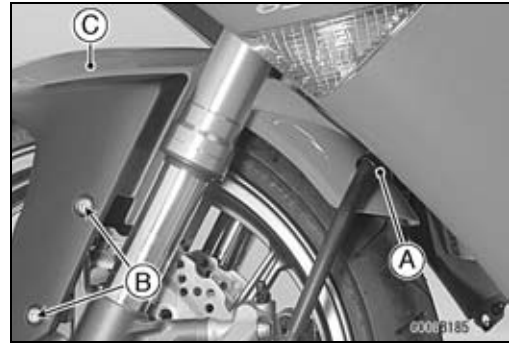

- Remove:
  - Bolts [A]
- Separate the front fender cover [B] and front fender [C].

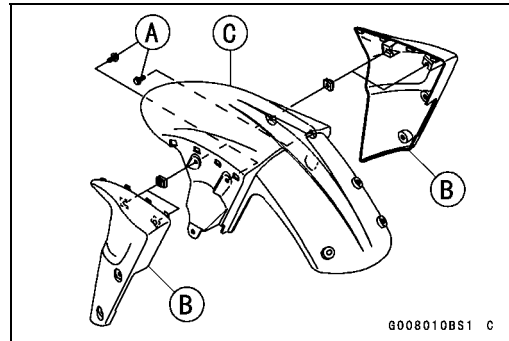

#### Front Fender Installation

- Install the front fender assy to the front fork.
- Tighten:
  - Torque - Front Fender Mounting Bolts: 3.9 N·m (0.40 kgf·m, 35 in·lb)**
- Install the brake hose clamps to the front fender holes.

#### Flap and Rear Fender Rear Removal

- Remove:
  - Seats (see Rear/Front Seat Removal in this chapter)
  - Seat Cover (see Seat Cover Removal in this chapter)
  - Fuel Tank (see Fuel Tank Removal in the Fuel System (DFI) chapter)
  - Relay Box [A] (see Relay Box Removal in the Electrical System chapter)
  - Starter Relay Assy (see Starter Relay Inspection in the Electrical System chapter)
  - Clamps [B]
  - Connectors [C]
  - Bolts [D]
  - Fuse Box [E]
  - Turn Signal Relay [F]
  - Owner's Tool [G]

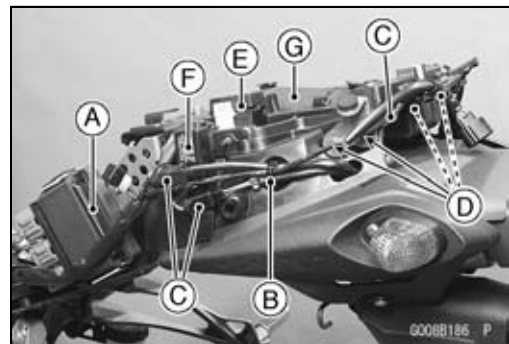

## Fenders

- Remove:
  - Nuts [A]
  - Bolts [B]
  - Flap [C] (with License Light)
  - Turn Signal Lights

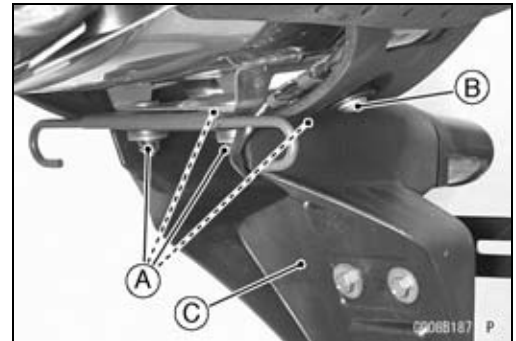

- Remove:
  - Muffler Body and Center Pipe (see Muffler Body Removal in the Engine Top End chapter)
  - Battery (see Battery Removal in the Electrical System chapter)
  - Exhaust Butterfly Valve Actuator (see Exhaust Butterfly Valve Actuator Removal in the Fuel System (DFI) chapter)
  - ECU (see ECU Removal in the Fuel System (DFI) chapter)
  - Bolts [A]
  - Screws [B]

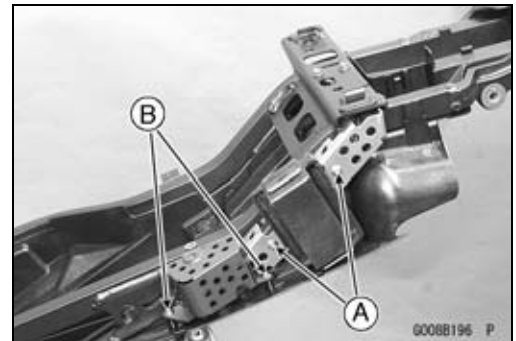

- Remove:
  - Bolts [A]
- Pull out the rear fender rear backward and downward.

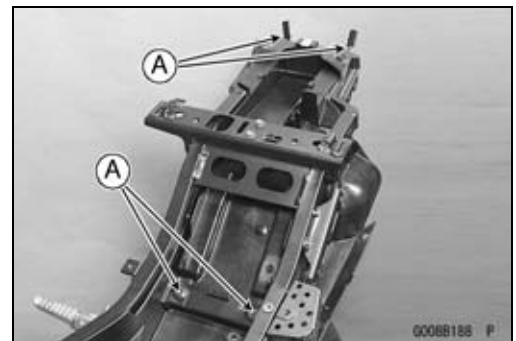

### *Flap and Rear Fender Rear Installation*

- Hang the hook [A] of the rear fender rear on the rear fender front.



## 15-18 FRAME

### Fenders

- Install the removed parts (see appropriate chapters).
- Install the harness clamp in accordance with Cable, Wire, and Hose Routing section in the Appendix chapter.
- Install the flap.
- ★ If there is a gap between the tire and flap, adjust it using the washer [A].

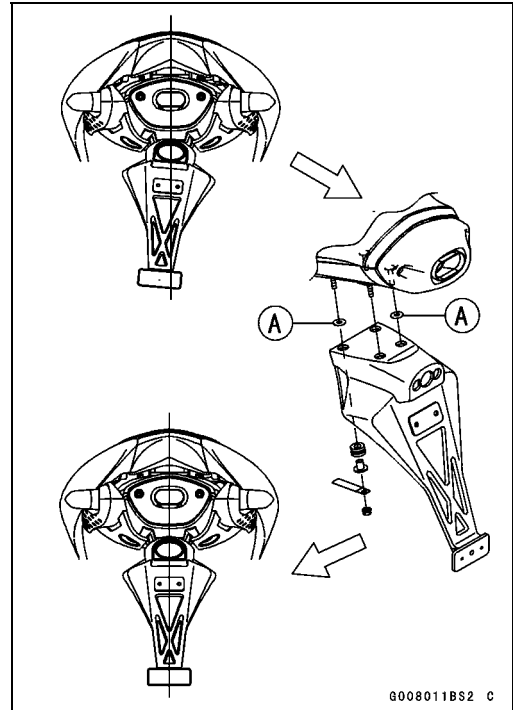

#### *Rear Fender Front Removal*

- Remove:
  - Rear Fender Rear (see Flap and Rear Fender Rear Removal in this chapter)
- Remove the rear fender front [A] upward.

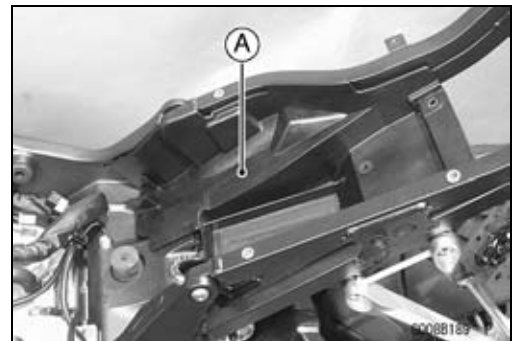

#### *Rear Fender Front Installation*

- Install the rear fender front on the chassis.
- Install the removed parts (see appropriate chapters).
- Run the harness correctly (see Cable, Wire, and Hose Routing section in the Appendix chapter).

## Frame

### Rear Frame Removal

- Remove:
  - Rear Fender Front (see Rear Fender Front Removal in this chapter)
  - Frame Bolts [A] and Nuts
  - Rear Footpeg Bracket Bolts [B] and Bracket (Both Side)

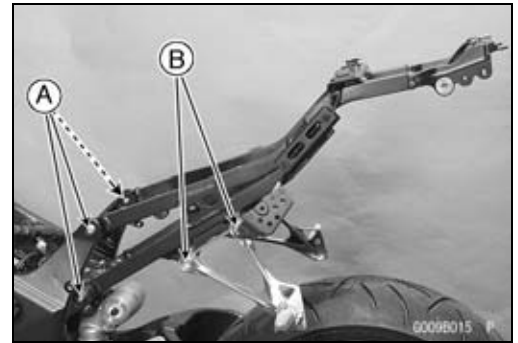

### Rear Frame Installation

- Apply a non-permanent locking agent to the threads of rear frame bolt.
- Tighten:
  - Torque - Rear Frame Bolts and Nuts: 59 N·m (6.0 kgf·m, 44 ft·lb)
  - Rear Footpeg Bracket Bolts: 25 N·m (2.5 kgf·m, 18 ft·lb)

### Frame Inspection

- Visually inspect the frame for cracks, dents, bending, or warp.
- ★ If there is any damage to the frame, replace it.

#### **⚠ WARNING**

**A repaired frame may fail in use, possibly causing an accident. If the frame is bent, dented, cracked, or warped, replace it.**

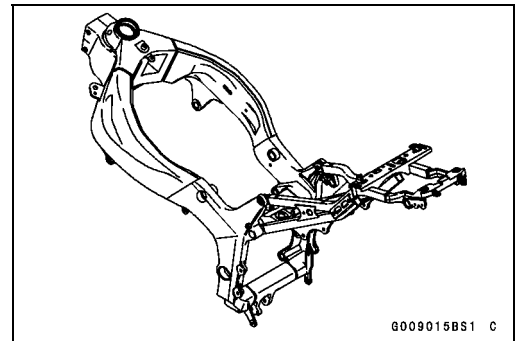

# 15-20 FRAME

## Side Stand

### Side Stand Removal

- Raise the rear wheel off the ground with the stand.
- Remove:
  - Lower Fairings (see Lower Fairing Removal in this chapter)
  - Fuel Tank (see Fuel Tank Removal in the Fuel System (DFI) chapter)
- Disconnect the side stand switch lead connector [A].



- Remove:
  - Side Stand Switch Bolt [A]
  - Spring [B]
  - Side Stand Bolt [C]
  - Side Stand [D]
  - Switch Bracket Bolts [E]
  - Side Stand Bracket Bolts [F]

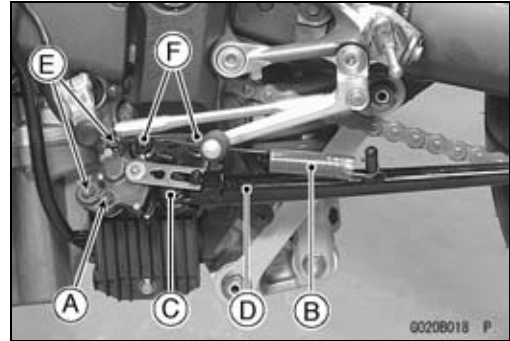

### Side Stand Installation

- Apply grease to the sliding area [A] of the side stand [B] and thread of the side stand bolt [C].
- Tighten the bolt and lock them with the nut.
  - Torque - Side Stand Bracket Bolts [D]: 49 N·m (5.0 kgf·m, 36 ft·lb)**
  - Side Stand Bolt: 44 N·m (4.5 kgf·m, 32 ft·lb)**
- Hook the spring [E] so that face the long spring end upward.
- Install the spring hook direction as shown.
- Install the switch bracket and side stand switch.
- Apply a non-permanent locking agent to the thread of the switch bolt.
- Torque - Side Stand Switch Bolt [F]: 8.8 N·m (0.90 kgf·m, 78 in·lb)**

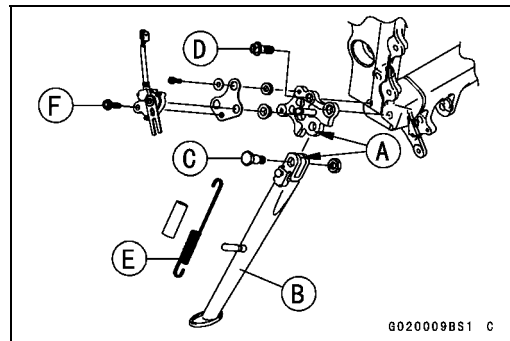

# Electrical System

## Table of Contents

Parts Location.....	16-3	Stick Coil (Ignition Coil together with Spark Plug Cap) Removal .	16-41
Exploded View.....	16-4	Stick Coil (Ignition Coil together with Spark Plug Cap) Installation.....	16-42
Wiring Diagram (United States, Canada and New Zealand).....	16-10	Stick Coil (Ignition Coil together with Spark Plug Cap) Inspection	16-42
Wiring Diagram (Other than United States, Canada, New Zealand, Australia and Malaysia) .....	16-12	Stick Coil Primary Peak Voltage ..	16-43
Wiring Diagram (Australia) .....	16-14	Spark Plug Removal .....	16-43
Wiring Diagram (Malaysia) .....	16-16	Spark Plug Installation .....	16-44
Specifications .....	16-18	Spark Plug Clean and Inspection.	16-44
Special Tools and Sealant .....	16-19	Spark Plug Gap Inspection .....	16-44
Precautions.....	16-20	Camshaft Position Sensor Removal .....	16-44
Electrical Wiring.....	16-22	Camshaft Position Sensor Installation.....	16-44
Wiring Inspection .....	16-22	Camshaft Position Sensor Inspection.....	16-44
Battery .....	16-23	Camshaft Position Sensor Peak Voltage Inspection.....	16-45
Battery Removal .....	16-23	Interlock Operation Inspection .....	16-46
Battery Installation .....	16-23	IC Igniter Inspection.....	16-47
Battery Activation .....	16-23	Electric Starter System.....	16-49
Precautions .....	16-26	Starter Motor Removal.....	16-49
Interchange .....	16-26	Starter Motor Installation.....	16-49
Charging Condition Inspection.....	16-27	Starter Motor Disassembly.....	16-49
Refreshing Charge.....	16-27	Starter Motor Assembly .....	16-49
Charging System.....	16-29	Brush Inspection .....	16-50
Alternator Cover Removal.....	16-29	Commutator Cleaning and Inspection.....	16-51
Alternator Cover Installation.....	16-29	Armature Inspection.....	16-51
Stator Coil Removal .....	16-29	Brush Lead Inspection .....	16-51
Stator Coil Installation .....	16-30	Right-hand End Cover Assembly Inspection.....	16-52
Alternator Rotor Removal .....	16-30	Starter Relay Inspection.....	16-52
Alternator Rotor Installation .....	16-30	Lighting System.....	16-54
Alternator Inspection .....	16-32	Headlight Beam Horizontal Adjustment .....	16-54
Regulator/Rectifier Removal .....	16-33	Headlight Beam Vertical Adjustment .....	16-54
Regulator/Rectifier Inspection.....	16-33	Headlight Bulb Replacement .....	16-54
Charging Voltage Inspection.....	16-35	City Light Bulb Replacement.....	16-55
Starter Motor Clutch .....	16-37	Headlight Removal/Installation .....	16-55
Starter Motor Clutch Removal/Inspection.....	16-37	Tail/Brake Light (LED) Removal...	16-56
Starter Motor Clutch Inspection .....	16-37	Tail/Brake Light (LED) Installation	16-56
Starter Motor Clutch Disassembly	16-37		
Starter Motor Clutch Assembly .....	16-37		
Ignition System.....	16-38		
Crankshaft Sensor Removal .....	16-39		
Crankshaft Sensor Installation.....	16-40		
Crankshaft Sensor Inspection.....	16-40		
Crankshaft Sensor Peak Voltage.	16-40		
Timing Rotor Removal .....	16-41		
Timing Rotor Installation .....	16-41		

## 16-2 ELECTRICAL SYSTEM

---

License Plate Light Bulb Replacement.....	16-56	Brake Light Timing Inspection.....	16-93
Turn Signal Light Bulb Replacement.....	16-58	Brake Light Timing Adjustment ....	16-93
Turn Signal Relay Inspection .....	16-59	Neutral Switch Replacement.....	16-93
Radiator Fan System.....	16-62	Switch Inspection .....	16-94
Fan Motor Inspection .....	16-62	Water Temperature Sensor Inspection.....	16-95
Meter, Gauge, Indicator Unit.....	16-64	Speed Sensor Removal .....	16-95
Meter Unit Removal .....	16-64	Speed Sensor Installation .....	16-95
Meter Unit Disassembly .....	16-64	Speed Sensor Inspection.....	16-96
Electronic Combination Meter Assembly Inspection .....	16-65	Fuel Reserve Switch Inspection...	16-96
Immobilizer System (Equipped Models).....	16-74	Relay Box .....	16-97
Operational Cautions .....	16-74	Relay Box Removal .....	16-97
Key Registration.....	16-74	Relay Circuit Inspection .....	16-97
Immobilizer System Parts Replacement.....	16-90	Diode Circuit Inspection .....	16-98
Immobilizer System Inspection ....	16-92	Fuse.....	16-100
Switches and Sensors .....	16-93	30 A Main Fuse Removal.....	16-100
		Fuse Box Fuse Removal.....	16-100
		15 A ECU Fuse Removal.....	16-100
		Fuse Installation.....	16-101
		Fuse Inspection.....	16-101

## Parts Location

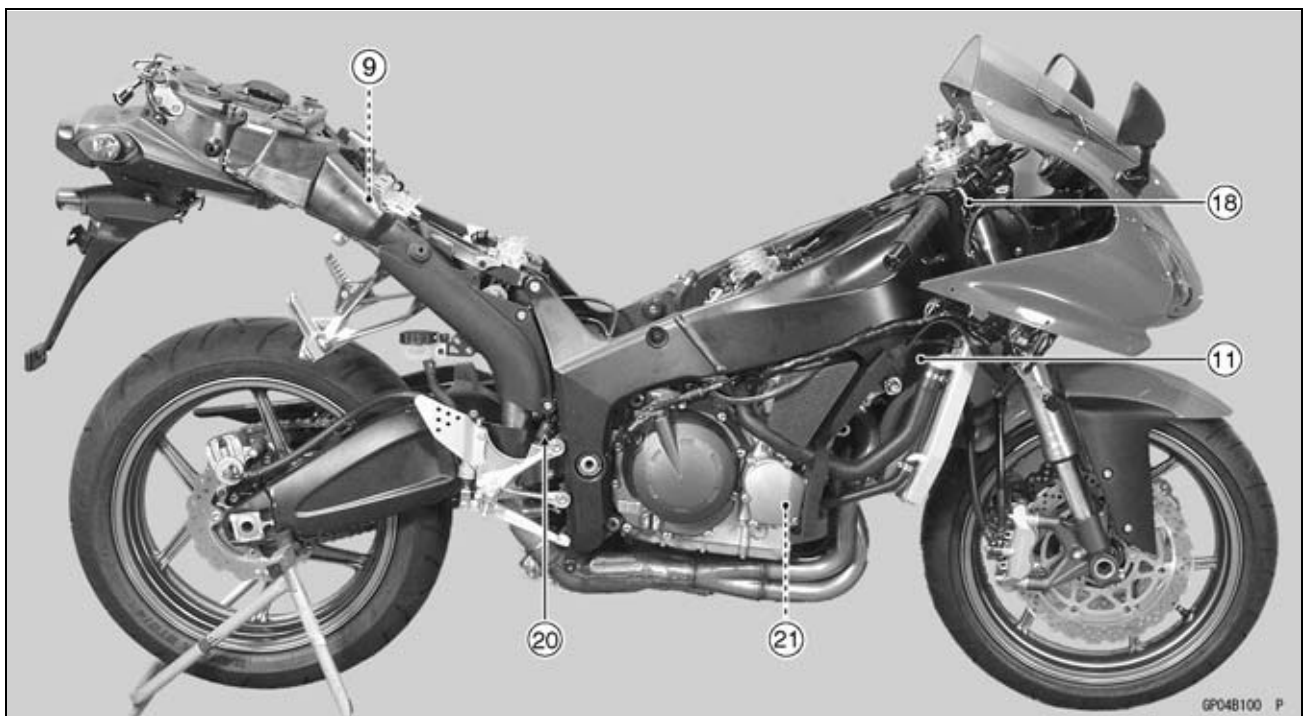
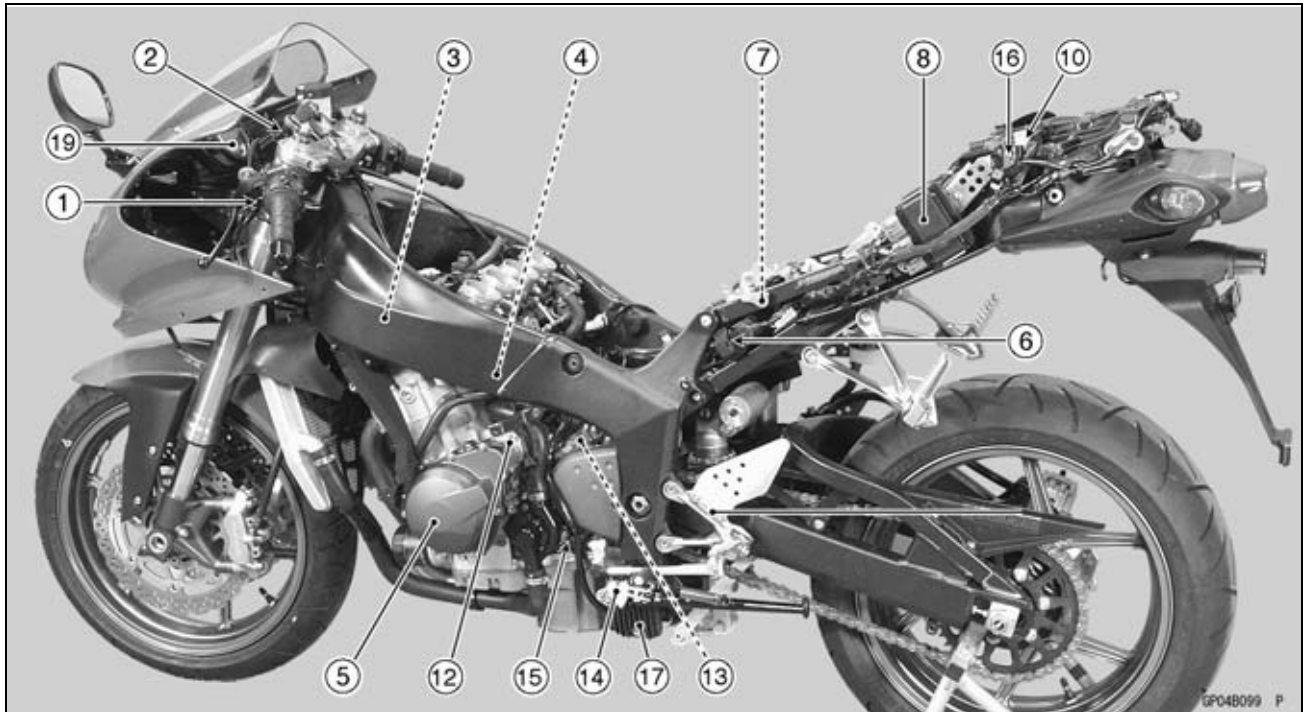

- |   |                              |
|---|------------------------------|
| 1. Starter Lockout Switch                   | 12. Starter Motor            |
| 2. Ignition Switch with Immobilizer Antenna | 13. Speed Sensor             |
| 3. Stick Coils                              | 14. Side Stand Switch        |
| 4. Water Temperature Sensor                 | 15. Neutral Switch           |
| 5. Alternator                               | 16. Turn Signal Relay        |
| 6. Starter Relay with Main Fuse             | 17. Regulator/rectifier      |
| 7. Battery 12 V 8 Ah                        | 18. Front Brake Light Switch |
| 8. Relay Box                                | 19. Meter Unit               |
| 9. ECU (Electric Control Unit)              | 20. Rear Brake Light Switch  |
| 10. Fuse Box with ECU Main Fuse             | 21. Crankshaft Sensor        |
| 11. Camshaft Position Sensor                |                              |

Immobilizer Amplifier (Right Center Fairing Side)

# 16-4 ELECTRICAL SYSTEM

## Exploded View

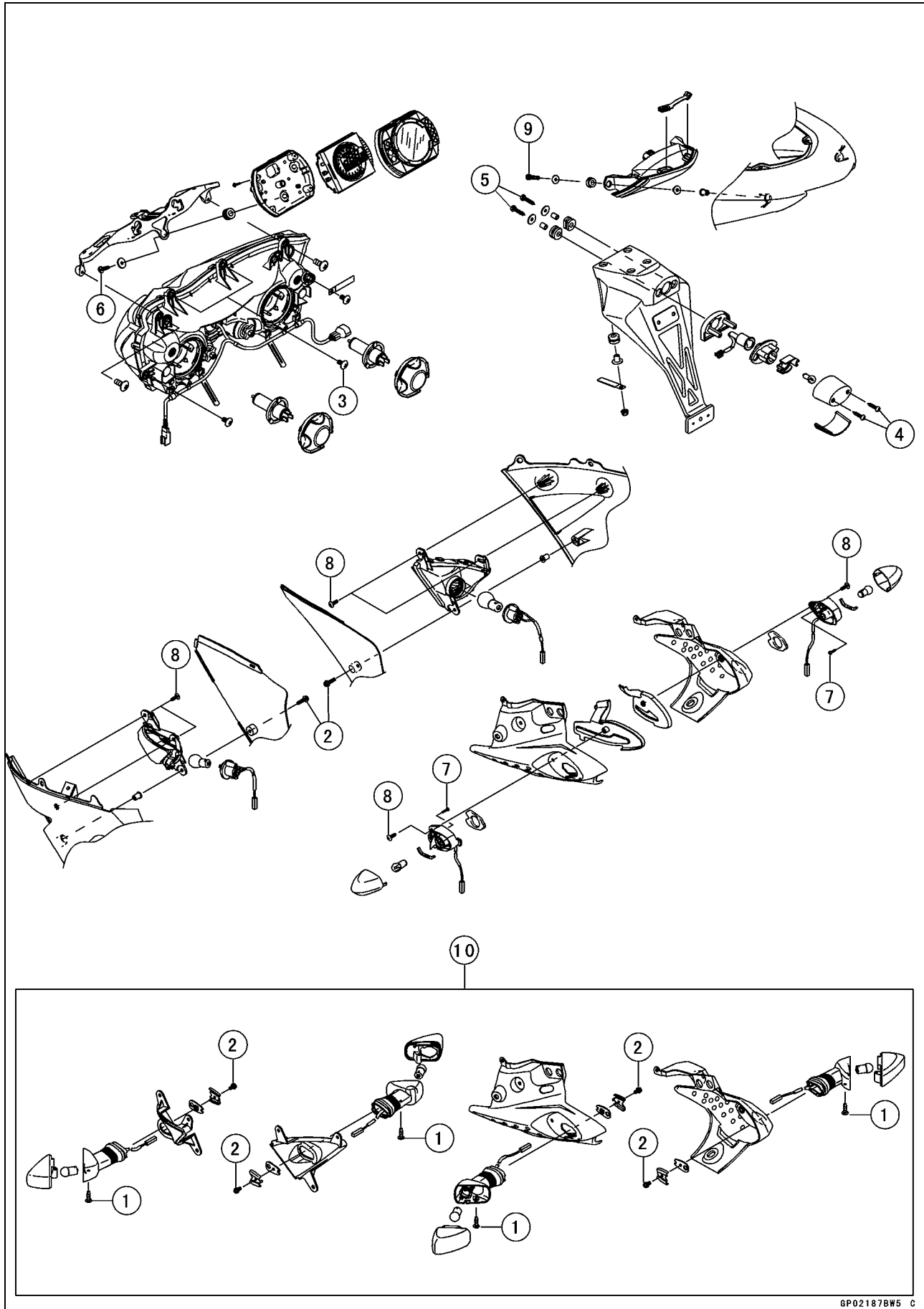

**Exploded View**

<b>No.</b>	<b>Fastener</b>	<b>Torque</b>			<b>Remarks</b>
		<b>N·m</b>	<b>kgf·m</b>	<b>ft·lb</b>	
1	Front Turn Signal Light Lens Screws	1.0	0.10	9 in·lb	
2	Front Turn Signal Light Mounting Screws	1.2	0.12	10 in·lb	
3	Headlight Mounting Screws	1.2	0.12	10 in·lb	
4	Licence Light Assembly Screws	0.9	0.09	8 in·lb	
5	Licence Light Mounting Screws	1.2	0.12	10 in·lb	
6	Meter Mounting Screws	1.2	0.12	10 in·lb	
7	Rear Turn Signal Light Lens Screws	1.0	0.10	9 in·lb	
8	Rear Turn Signal Light Mounting Screws	1.2	0.12	10 in·lb	
9	Tail/Brake Light Mounting Screws	4.0	0.40	35 in·lb	

10. United States and Canada Models

# 16-6 ELECTRICAL SYSTEM

## Exploded View

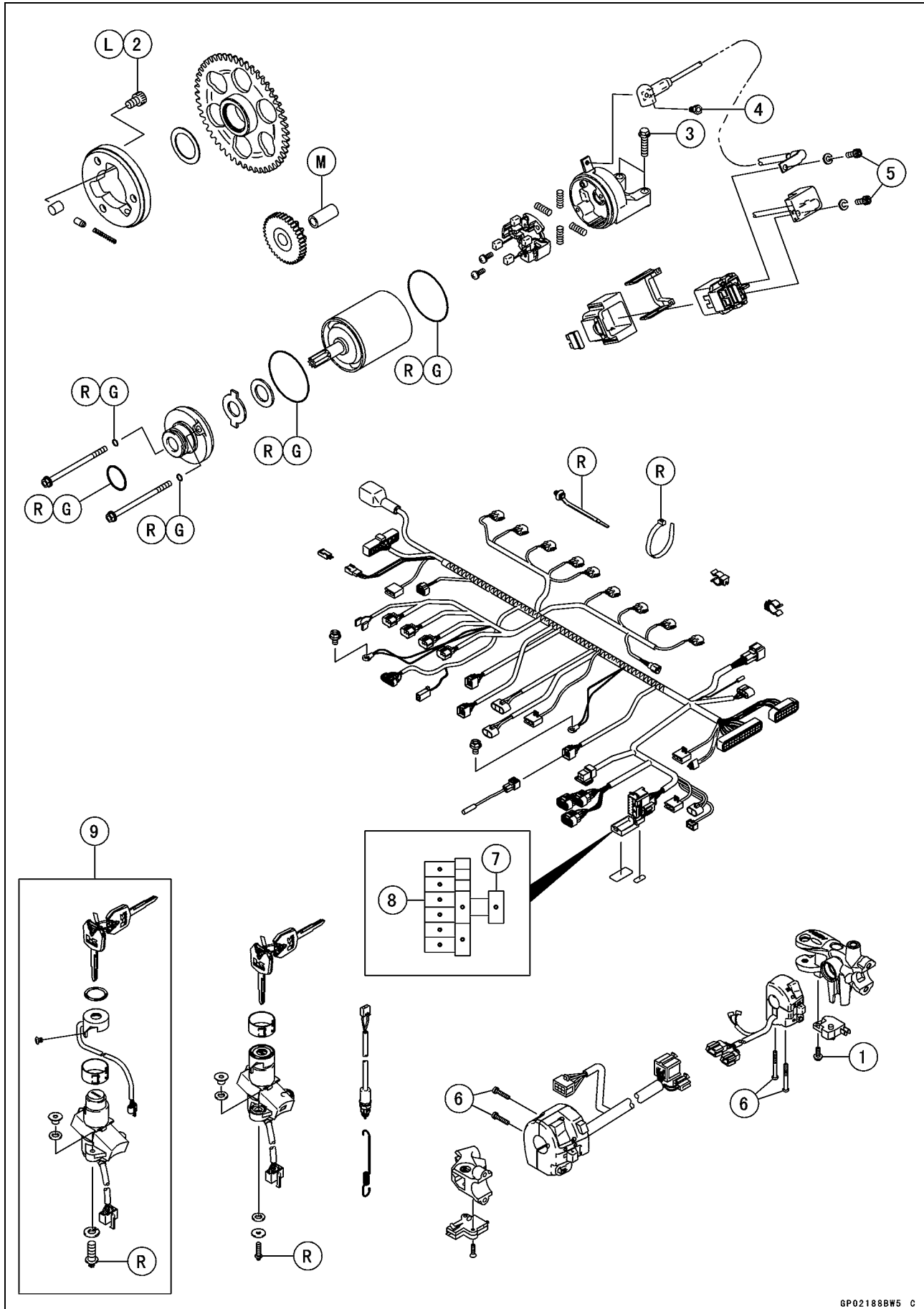

**Exploded View**

No.	Fastener	Torque			Remarks
		N·m	kgf·m	ft·lb	
1	Front Brake Light Switch Screw	1.2	0.12	10 in·lb	
2	Starter Motor Clutch Bolts	34	3.5	25	L
3	Starter Motor Mounting Bolts	11	1.1	97 in·lb	
4	Starter Motor Cable Terminal Bolt	2.7	0.28	24 in·lb	
5	Starter Relay Cable Terminal Bolts	3.9	0.40	35 in·lb	
6	Switch Housing Screws	3.5	0.36	31 in·lb	

7. ECU Main Fuse

8. Fuse Box

9. Immobilizer Models

G: Apply grease.

M: Apply molybdenum disulfide grease.

R: Replacement Parts

# 16-8 ELECTRICAL SYSTEM

## Exploded View

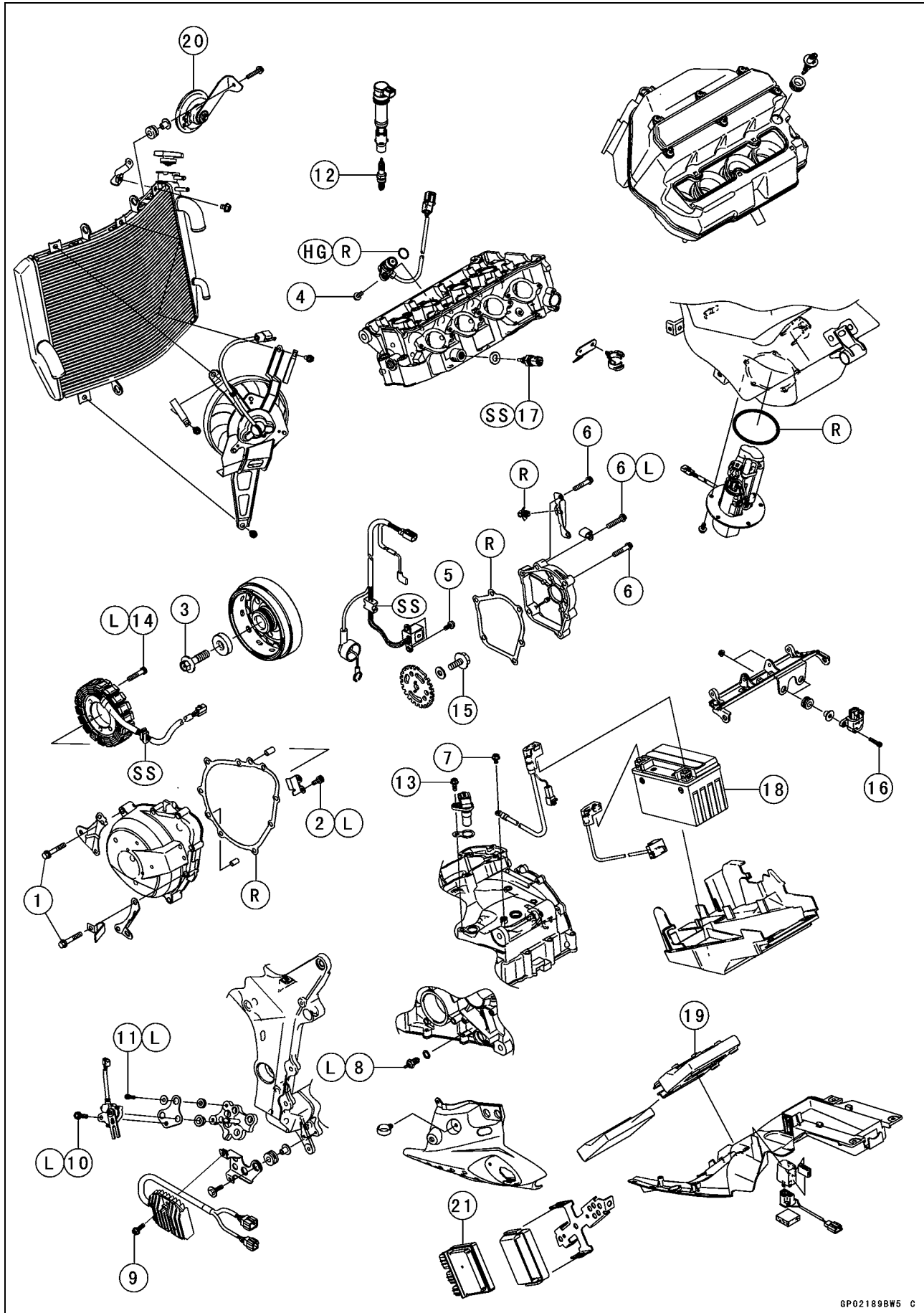

## Exploded View

No.	Fastener	Torque			Remarks
		N·m	kgf·m	ft·lb	
1	Alternator Cover Bolts	12	1.2	104 in·lb	
2	Alternator Lead Holding Plate Bolts	6.9	0.70	61 in·lb	L
3	Alternator Rotor Bolt	110	11	81	
4	Camshaft Position Sensor Bolt	12	1.2	104 in·lb	
5	Crankshaft Sensor Bolts	5.9	0.60	52 in·lb	
6	Crankshaft Sensor Cover Bolts	9.8	1.0	87 in·lb	L (1)
7	Engine Ground Lead Terminal Bolt	9.8	1.0	87 in·lb	
8	Neutral Switch	15	1.5	11	L
9	Regulator/Rectifier Bolts	6.9	0.70	61 in·lb	
10	Side Stand Switch Bolt	8.8	0.90	78 in·lb	L
11	Side Stand Switch Bracket Bolt	3.9	0.40	35	L
12	Spark Plugs	13	1.3	115 in·lb	
13	Speed Sensor Bolt	12	1.2	104 in·lb	
14	Stator Coil Bolts	12	1.2	104 in·lb	L
15	Timing Rotor Bolt	45	4.5	33	
16	Vehicle-down Sensor Bolts	5.9	0.60	52 in·lb	
17	Water Temperature Sensor	25	2.5	18	SS

18. Battery

19. ECU

20. Horn

21. Relay Box

HG: Apply high-temperature grease.

L: Apply a non-permanent locking agent.

R: Replacement Parts

SS: Apply silicone sealant.

# 16-10 ELECTRICAL SYSTEM

## Wiring Diagram (United States, Canada and New Zealand)

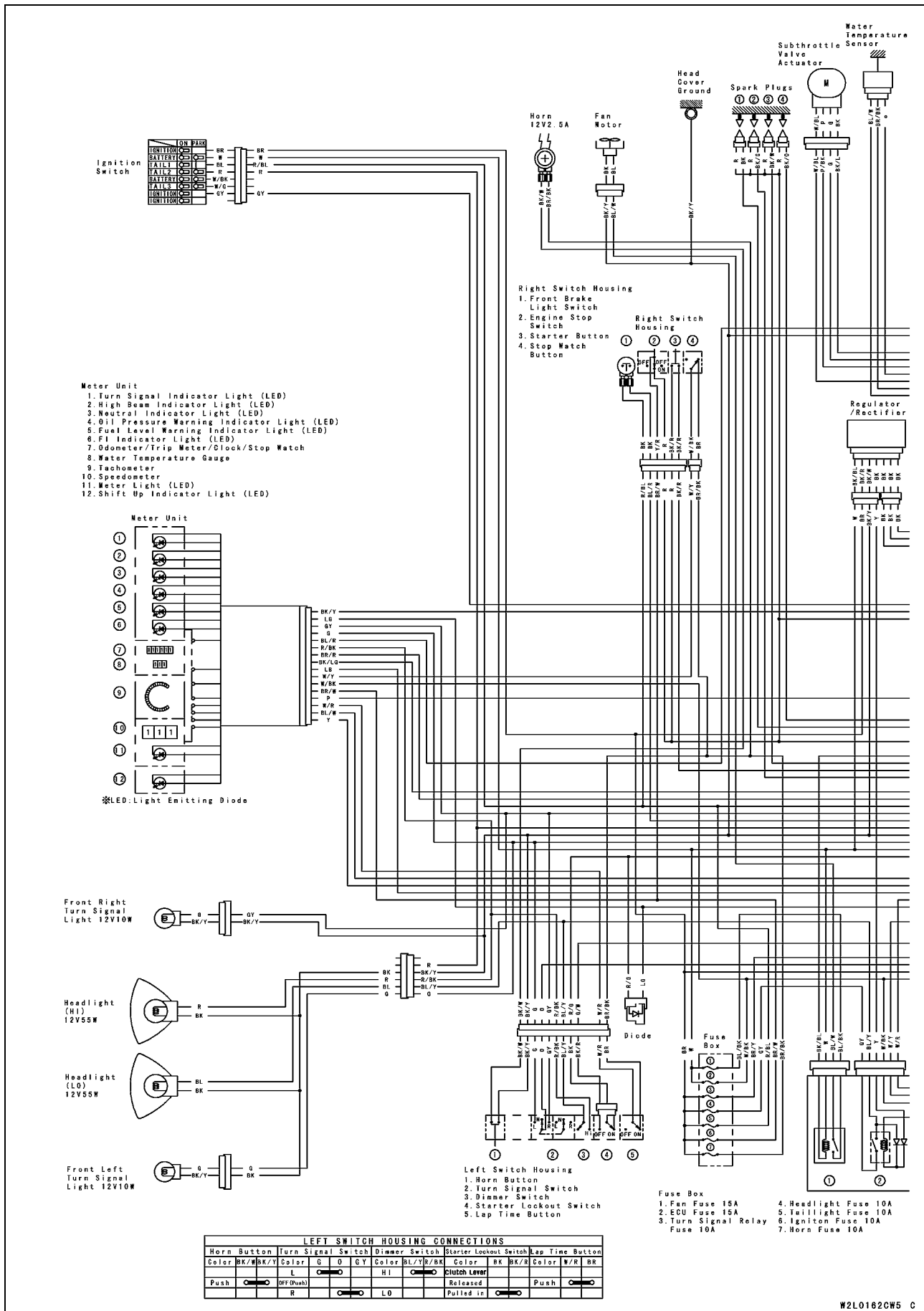

## Wiring Diagram (United States, Canada and New Zealand)

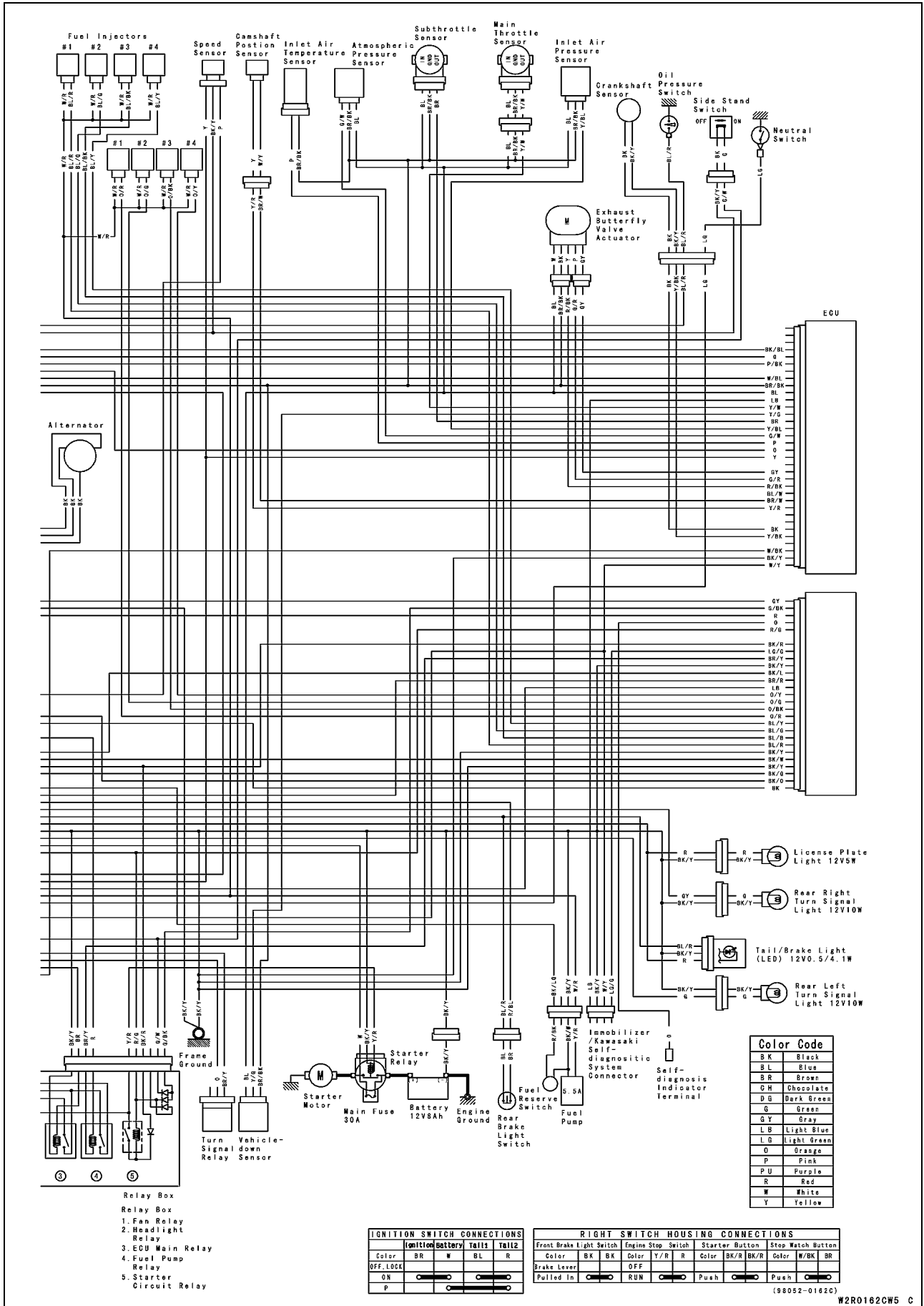

# 16-12 ELECTRICAL SYSTEM

## Wiring Diagram (Other than United States, Canada, New Zealand, Australia and Malaysia)

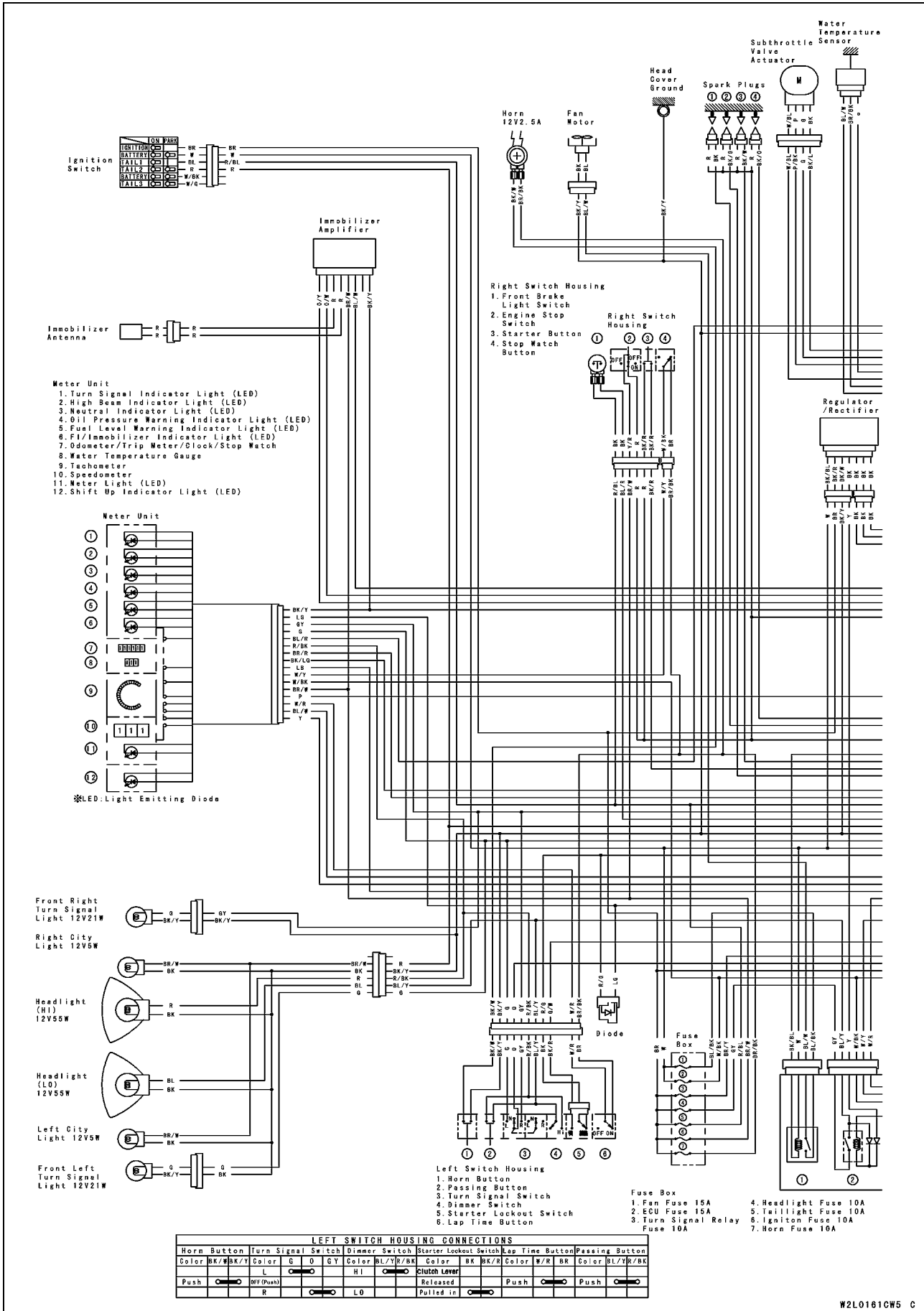

## Wiring Diagram (Other than United States, Canada, New Zealand, Australia and Malaysia)

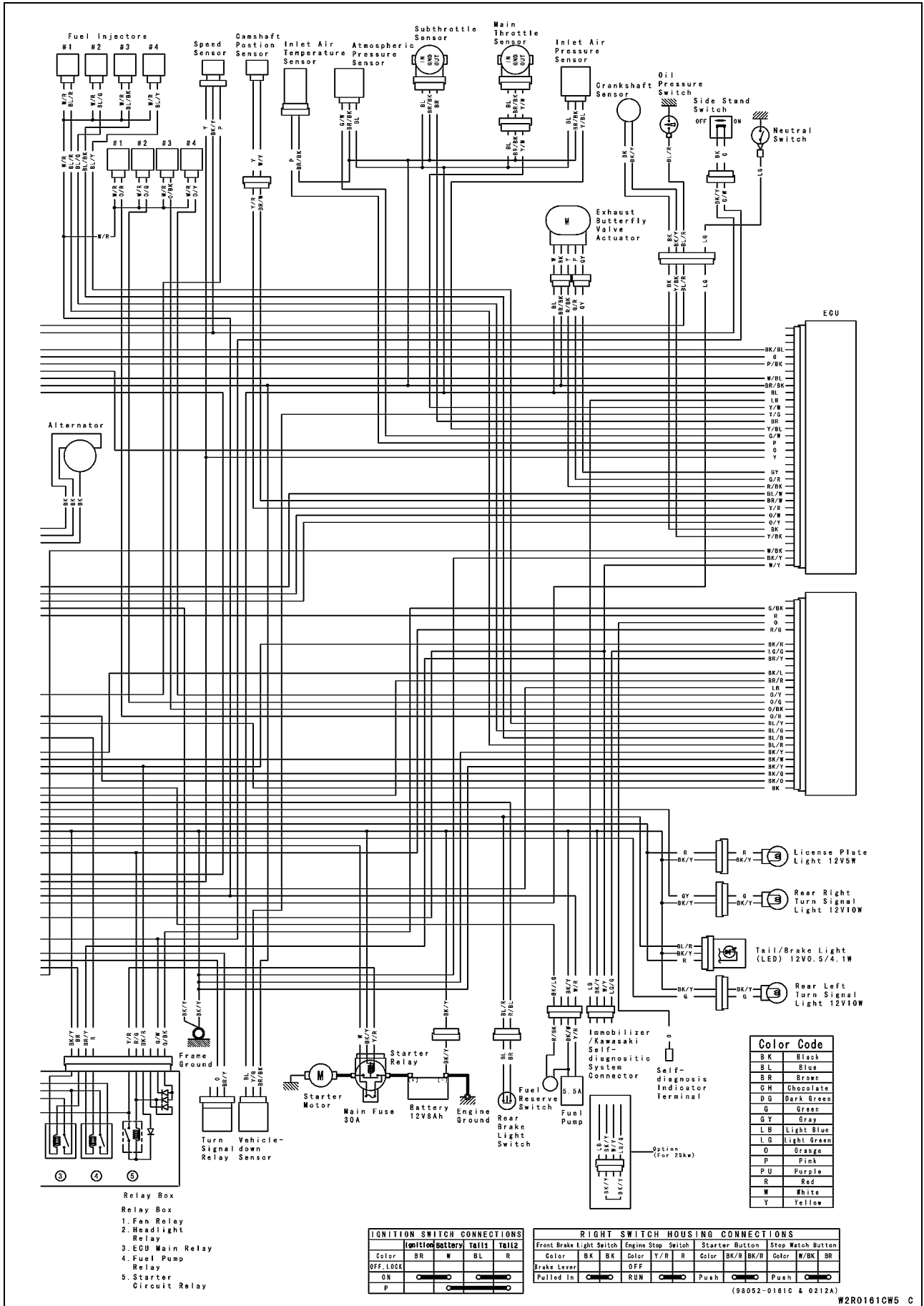

Color Code	Color
BK	Black
BL	Blue
BR	Brown
CH	Chocolate
DG	Dark Green
G	Green
GY	Gray
LB	Light Blue
LG	Light Green
O	Orange
P	Pink
PU	Purple
R	Red
W	White
Y	Yellow

Color	IGNITION SWITCH CONNECTIONS			
	Ignition	Battery	Tail1	Tail2
Color	BR	W	BL	R
OFF LOCK	○	○	○	○
ON	○	○	○	○
P	○	○	○	○

RIGHT SWITCH HOUSING CONNECTIONS									
Front Brake Light Switch		Engine Stop Switch		Starter Button		Stop Watch Button			
Color	BK	BK	Color	Y/R	R	Color	W/BK	BR	
Brake Lever	OFF	OFF	Color	Y/R	R	Color	BK/R	BK/R	
Pulled In	○	○	RUN	○	○	Push	○	Push	○

# 16-14 ELECTRICAL SYSTEM

## Wiring Diagram (Australia)

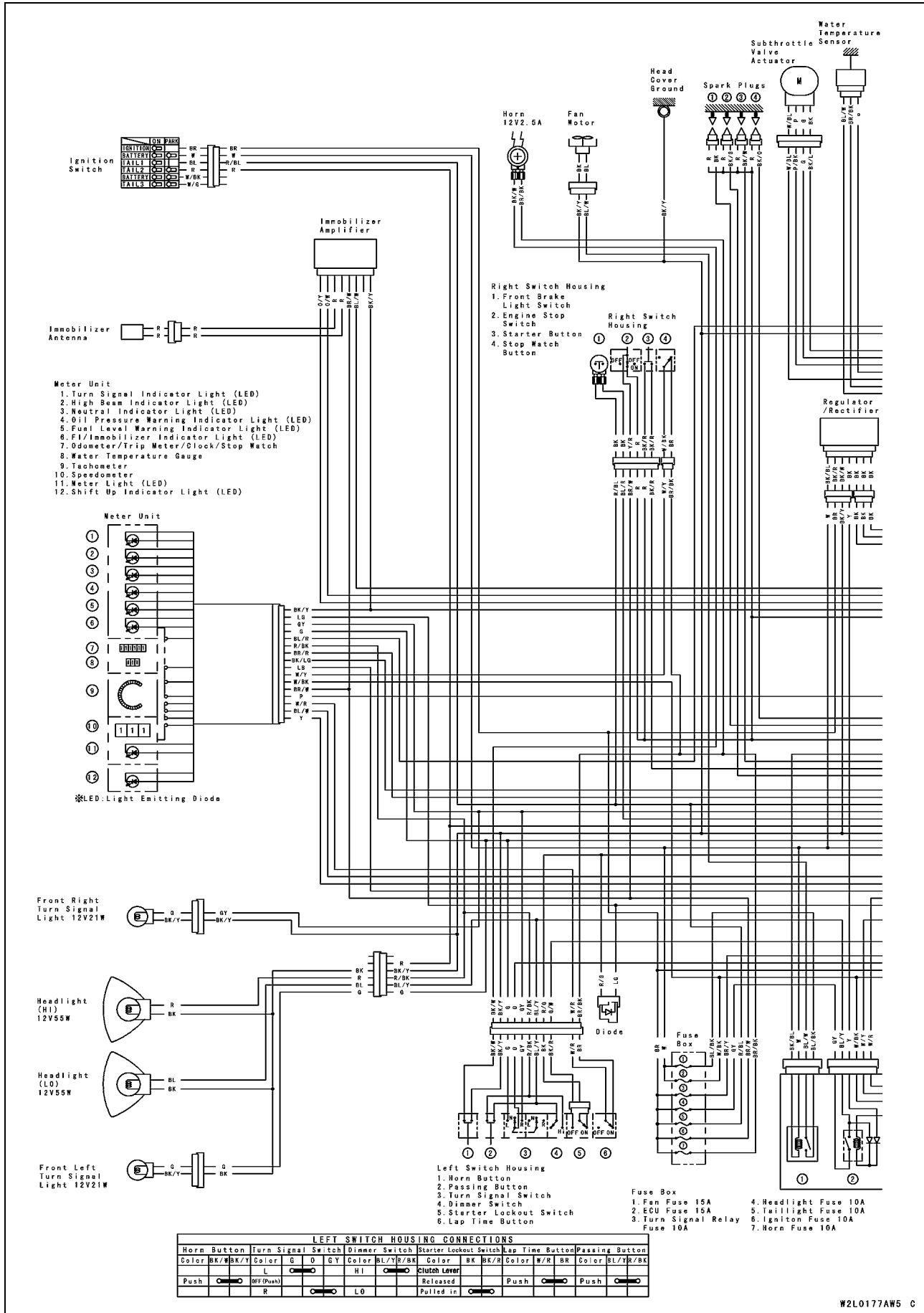

## Wiring Diagram (Australia)

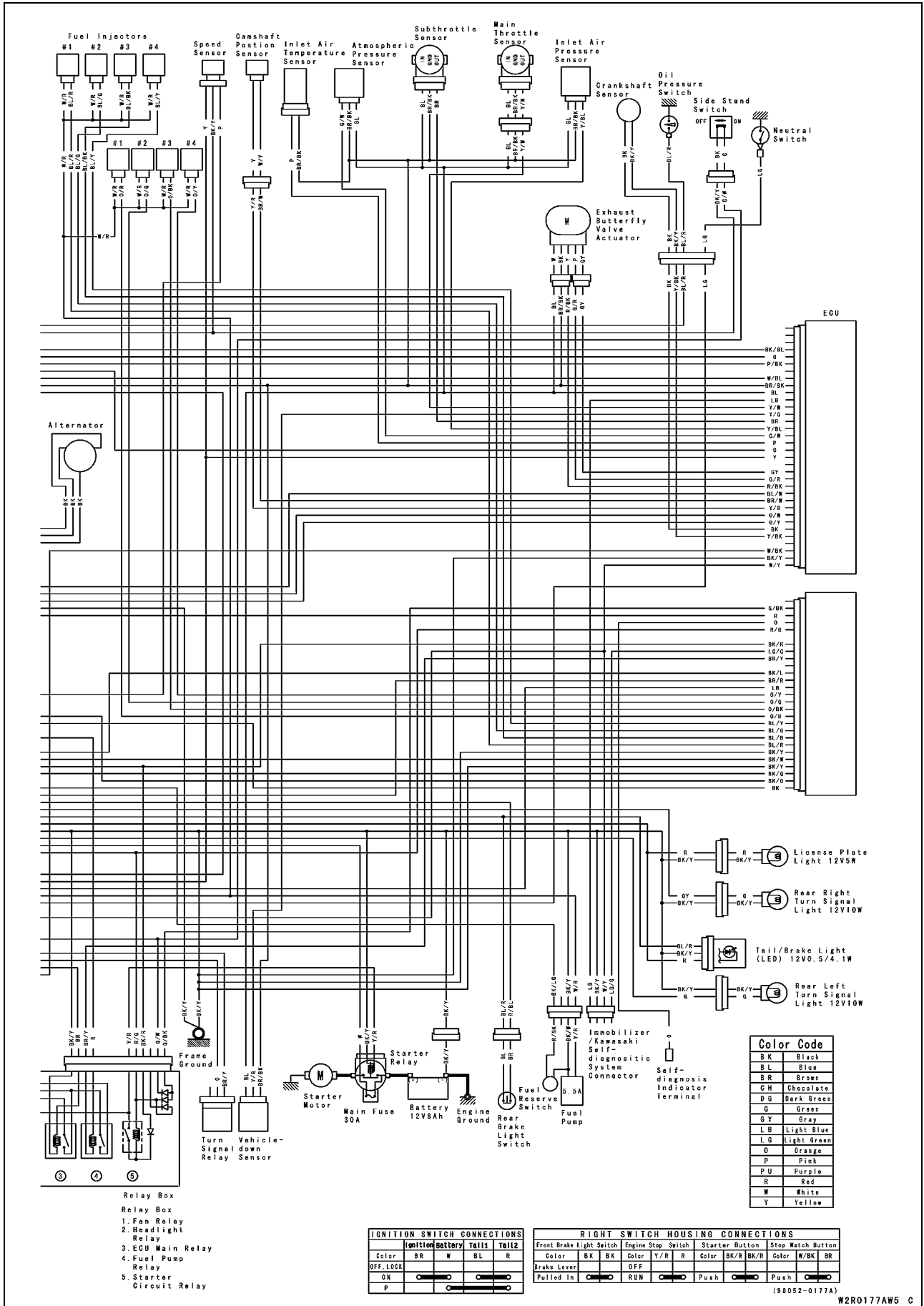

# 16-16 ELECTRICAL SYSTEM

## Wiring Diagram (Malaysia)

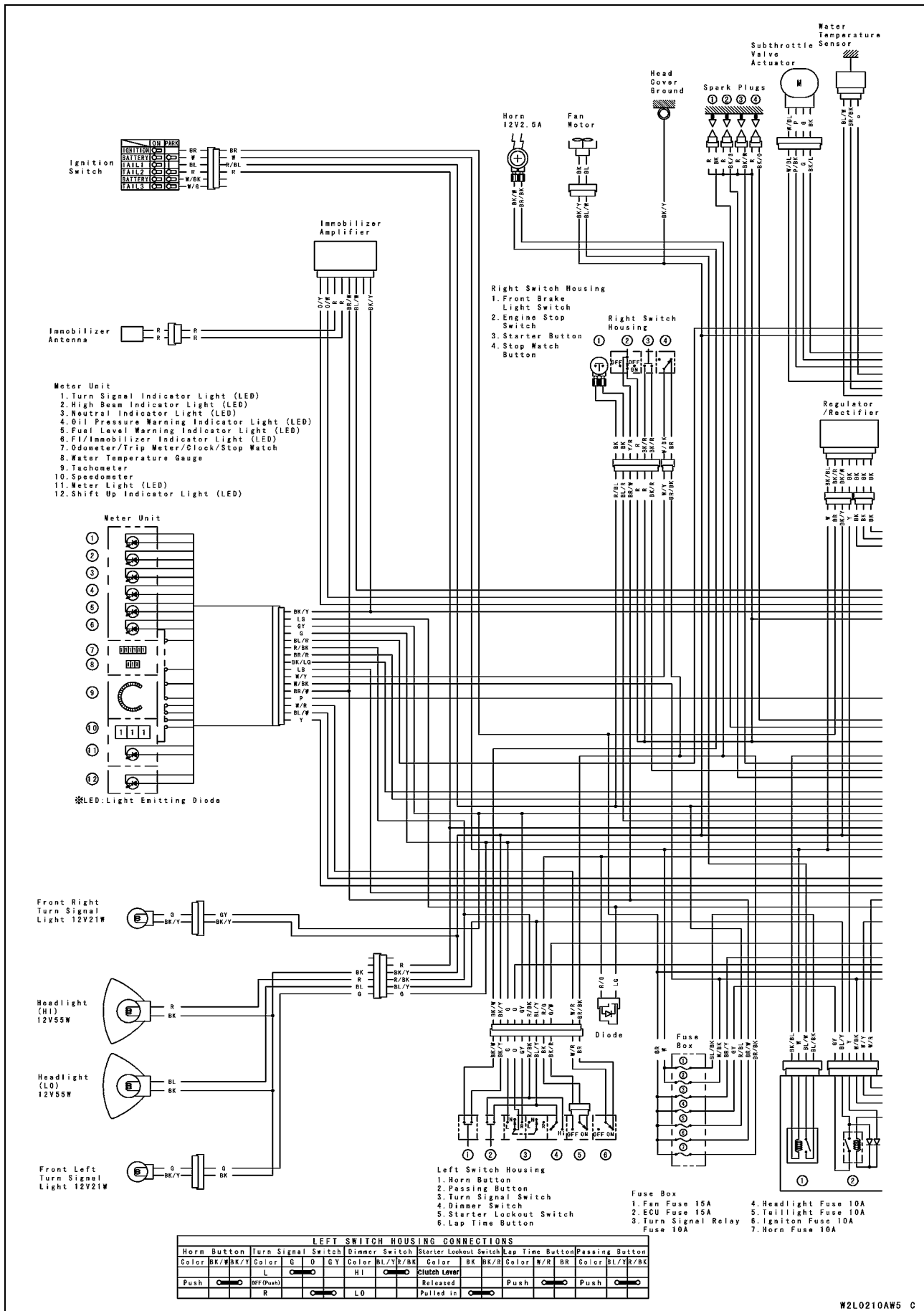

## Wiring Diagram (Malaysia)

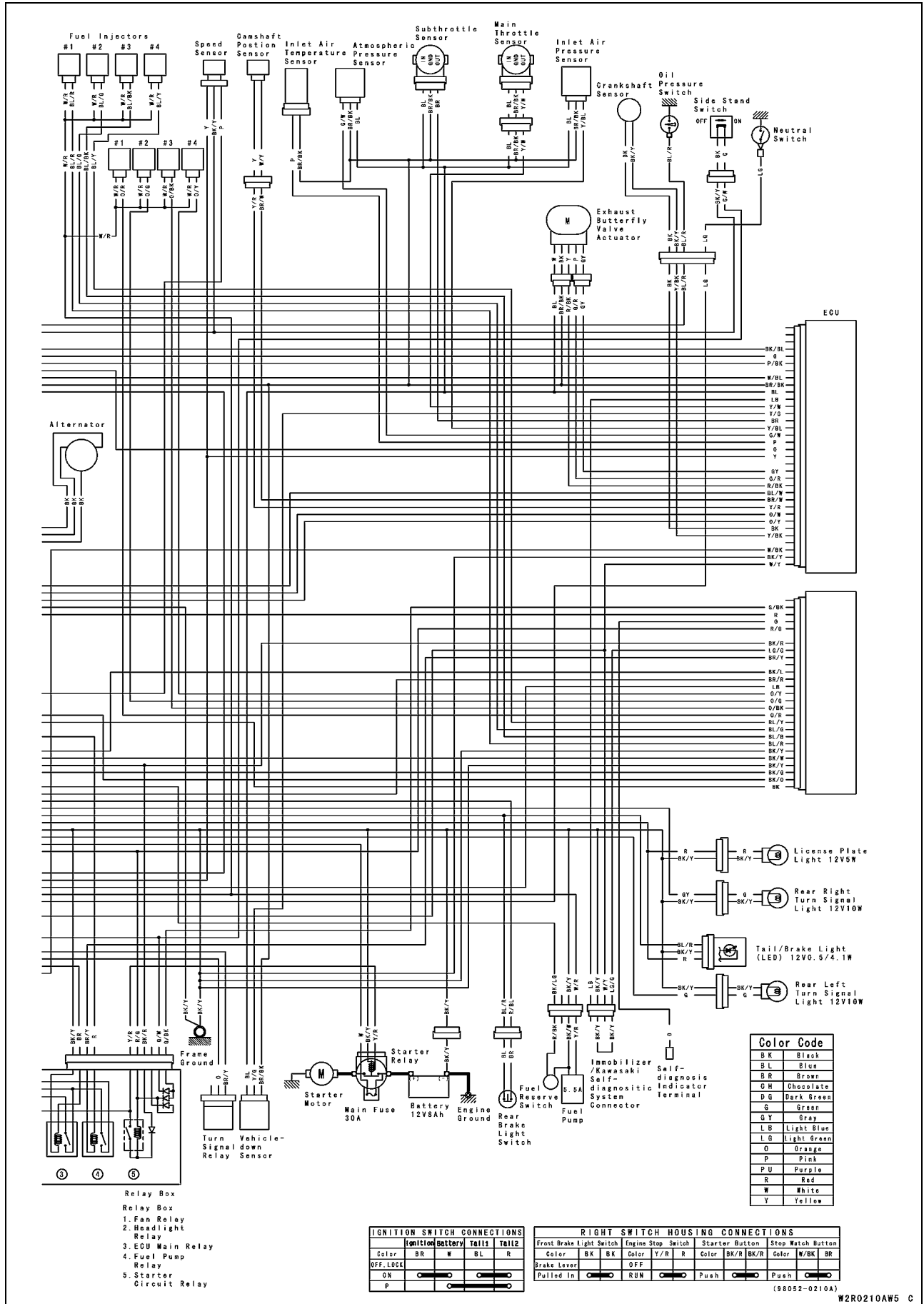

## 16-18 ELECTRICAL SYSTEM

### Specifications

Item	Standard
<b>Battery</b>	
Type	Sealed battery
Capacity	12 V 8 Ah
Voltage	12.8 V or more
<b>Charging System</b>	
Type	Three-phase AC
Alternator Output Voltage	42 V or more @4 000 r/min (rpm)
Stator Coil Resistance	0.3 ~ 0.4 $\Omega$
Charging Voltage (Regulator/rectifier Output Voltage)	14.2 ~ 15.2 V
<b>Ignition System</b>	
Crankshaft Sensor Resistance	380 ~ 570 $\Omega$
Crankshaft Sensor Peak Voltage	3.2 V or more
Camshaft Position Sensor Resistance	400 ~ 460 $\Omega$
Camshaft Position Sensor Peak Voltage	0.4 V or more
Spark Plug Gap	0.7 mm ~ 0.8 mm (0.028 ~ 0.032 in.)
Stick Coil:	
Primary Winding Resistance	1.2 ~ 1.6 $\Omega$
Secondary Winding Resistance	8.5 ~ 11.5 k $\Omega$
Primary Peak Voltage	100 V or more
<b>Electric Starter System</b>	
Starter Motor:	
Brush Length	7 mm (0.28 in.), Service Limit: 3.5 mm (0.14 in.)
Commutator Diameter	24 mm (0.94 in.), Service Limit: 23 mm (0.91 in.)
<b>Switch and Sensor</b>	
Rear Brake Light Switch Timing	ON after about 10 mm (0.39 in.) pedal travel
Engine Oil Pressure Switch Connections	When engine is stopped: ON When engine is running: OFF
Fan Switch Resistance:	
Rising Temperature	From OFF to ON @93 ~ 103°C (199 ~ 217°F)
Falling Temperature	Fan stops with the temperature 3 ~ 8°C (38 ~ 46°F) lower than the operation temperature range.
	ON: Less than 0.5 $\Omega$ OFF: More than 10 M $\Omega$
Water Temperature Sensor Resistance	In the text

Special Tools and Sealant

Flywheel Holder:  
57001-1313

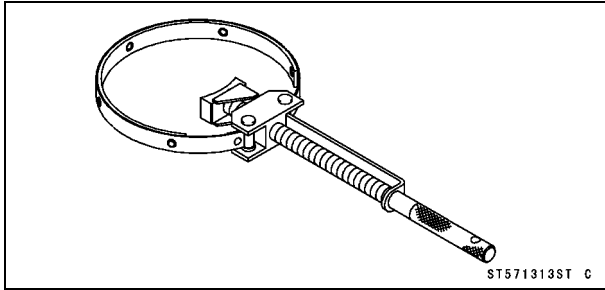

Harness Adapter:  
57001-1542

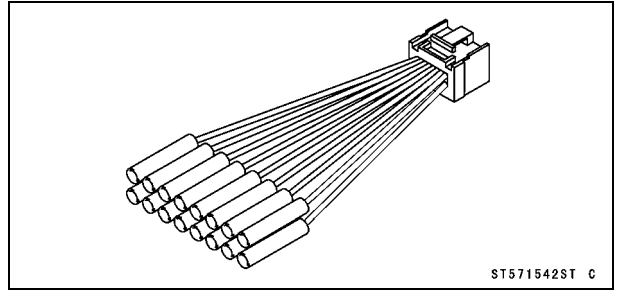

Hand Tester:  
57001-1394

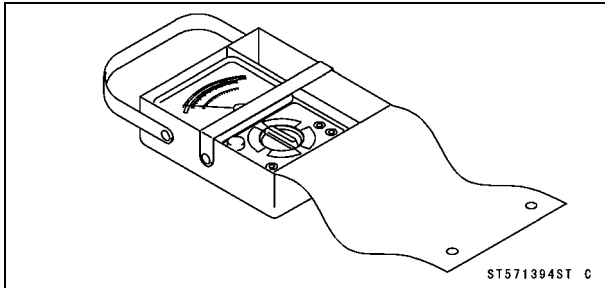

Key Registration Unit:  
57001-1582

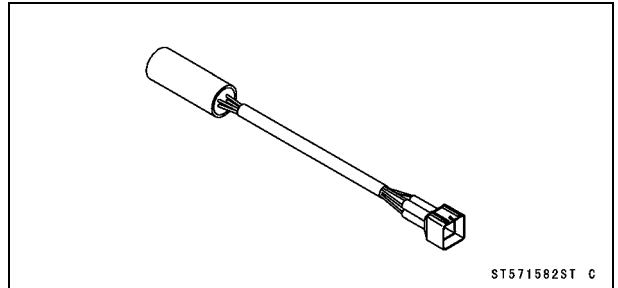

Flywheel Puller Assembly, M38 × 1.5/M35 × 1.5:  
57001-1405

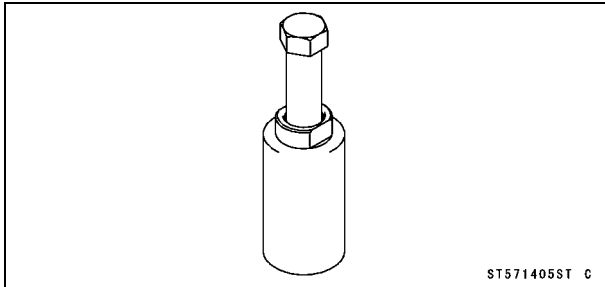

Flywheel & Pulley Holder:  
57001-1605

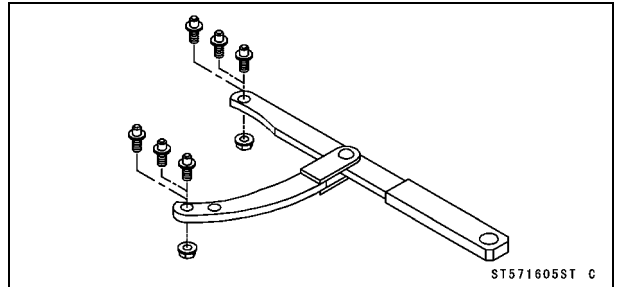

Peak Voltage Adapter:  
57001-1415

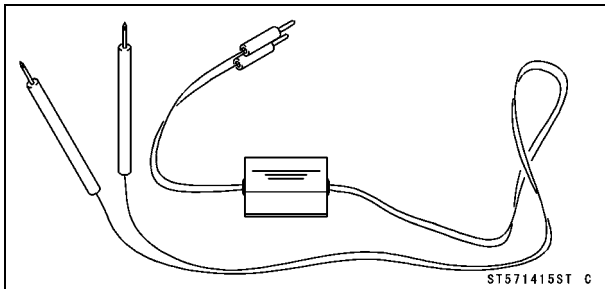

Kawasaki Bond (Silicone Sealant):  
56019-120

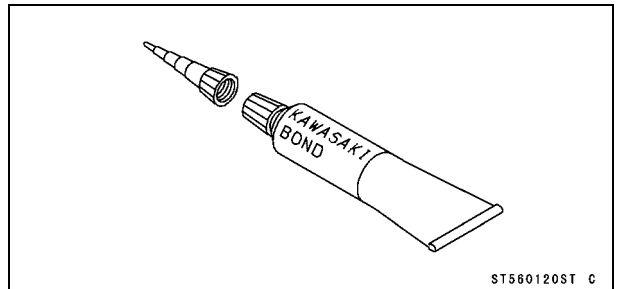

Lead Wire - Peak Voltage Adapter:  
57001-1449

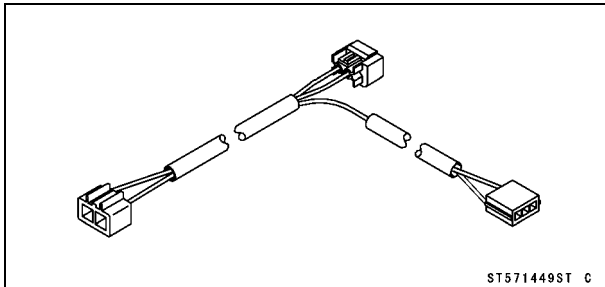

Kawasaki Bond (Silicone Sealant):  
92104-0004

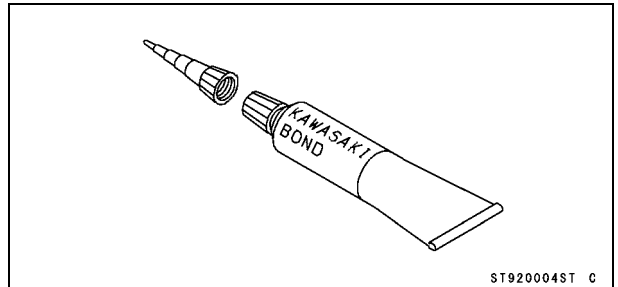

# 16-20 ELECTRICAL SYSTEM

## Precautions

There are a number of important precautions that are musts when servicing electrical systems. Learn and observe all the rules below.

- Do not reverse the battery lead connections. This will burn out the diodes on the electrical parts.
- Always check battery condition before condemning other parts of an electrical system. A fully charged battery is a must for conducting accurate electrical system tests.
- The electrical parts should never be struck sharply, as with a hammer, or allowed to fall on a hard surface. Such a shock to the parts can damage them.
- To prevent damage to electrical parts, do not disconnect the battery cables or any other electrical connections when the ignition switch is on, or while the engine is running.
- Because of the large amount of current, never keep the starter button pushed when the starter motor will not turn over, or the current may burn out the starter motor windings.
- Do not use a meter illumination bulb rated for other than voltage or wattage specified in the wiring diagram, as the meter or gauge panel could be warped by excessive heat radiated from the bulb.
- Take care not to short the cables that are directly connected to the battery positive (+) terminal to the chassis ground.
- Troubles may involve one or in some cases all items.  
Never replace a defective part without determining what CAUSED the failure. If the failure was caused by some other item or items, they must be repaired or replaced, or the new replacement will soon fail again.
- Make sure all connectors in the circuit are clean and tight, and examine wires for signs of burning, fraying, etc. Poor wires and bad connections will affect electrical system operation.
- Measure coil and winding resistance when the part is cold (at room temperature).
- Color Codes:

BK: Black	G: Green	P: Pink
BL: Blue	GY: Gray	PU: Purple
BR: Brown	LB: Light Blue	R: Red
CH: Chocolate	LG: Light Green	W: White
DG: Dark Green	O: Orange	Y: Yellow

- Electrical Connectors  
Female Connectors [A]

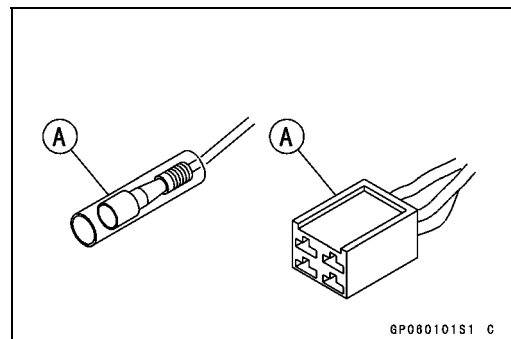

Precautions

Male Connectors [B]

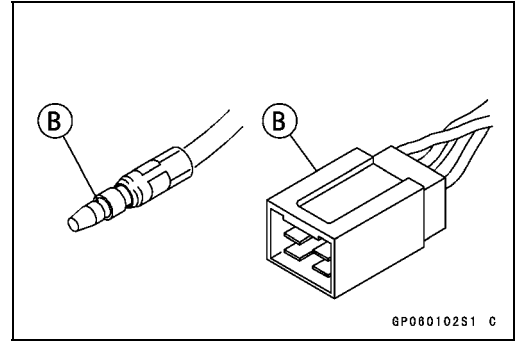

## 16-22 ELECTRICAL SYSTEM

### Electrical Wiring

#### Wiring Inspection

- Visually inspect the wiring for signs of burning, fraying, etc.
- ★ If any wiring is poor, replace the damaged wiring.
- Pull each connector [A] apart and inspect it for corrosion, dirt, and damage.
- ★ If the connector is corroded or dirty, clean it carefully. If it is damaged, replace it.
- Check the wiring for continuity.
- Use the wiring diagram to find the ends of the lead which is suspected of being a problem.
- Connect the hand tester between the ends of the leads.

#### Special Tool - Hand Tester: 57001-1394

- Set the tester to the  $\times 1 \Omega$  range, and read the tester.
- ★ If the tester does not read  $0 \Omega$ , the lead is defective. Replace the lead or the wiring harness [B] if necessary.

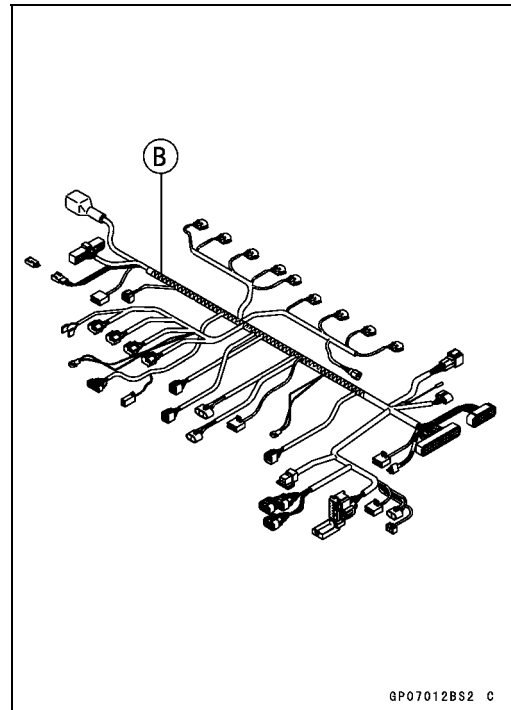
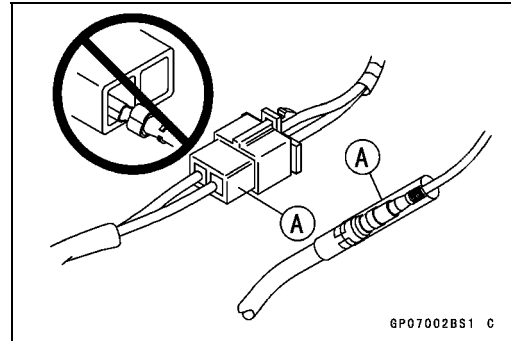

## Battery

### Battery Removal

- Remove:
  - Front Seat (see Front Seat Removal in the Frame chapter)
  - Fuel Tank (see Fuel Tank Removal in the Fuel System (DFI) chapter)
  - Bolts [A]
  - Connector [B]
  - Fuel Tank Bracket [C]

- Slide the caps [A].
- Disconnect the negative (-) cable [B] and then positive (+) cable [C].

#### CAUTION

**Be sure to disconnect the negative (-) cable first.**

- Remove the battery.

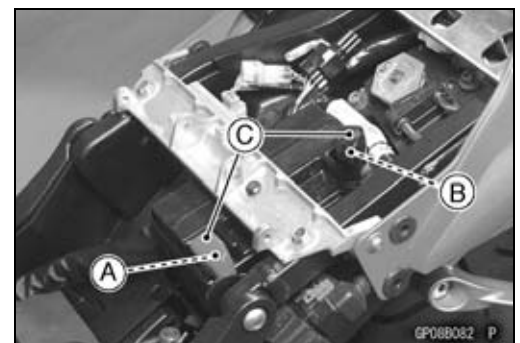
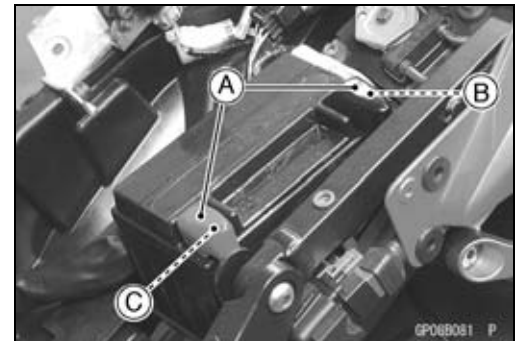
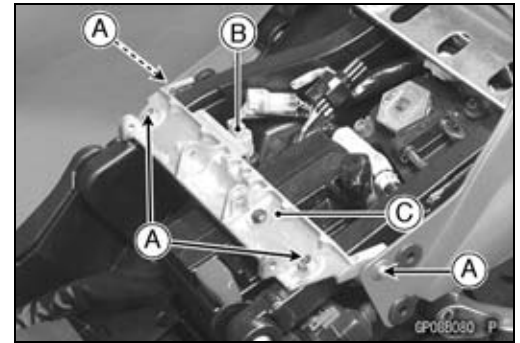

### Battery Installation

- Visually inspect the surface of the battery container.
- ★ If any signs of cracking or electrolyte leakage from the sides of the battery.
- Put the battery into the battery case.
- Install the fuel tank bracket and connector.
- Connect the positive cable [A] (red cap) to the (+) terminal first, and then the negative cable [B] to the (-) terminal.
- Apply a light coat of grease on the terminals to prevent corrosion.
- Cover the terminals with the caps [C].

#### CAUTION

**If each battery cable is not correctly disconnected or connected, sparks can arise at electrical connections, causing damage to electrical and DFI parts.**

### Battery Activation

#### Electrolyte Filling

- Make sure that the model name [A] of the electrolyte container matches the model name [B] of the battery. These names must be the same.

**Battery Model Name for ZX636C: YTX9-BS**

#### CAUTION

**Be sure to use the electrolyte container with the same model name as the battery since the electrolyte volume and specific gravity vary with the battery type. This is to prevent overfilling of the electrolyte, shorting the battery life, and deterioration of the battery performance.**

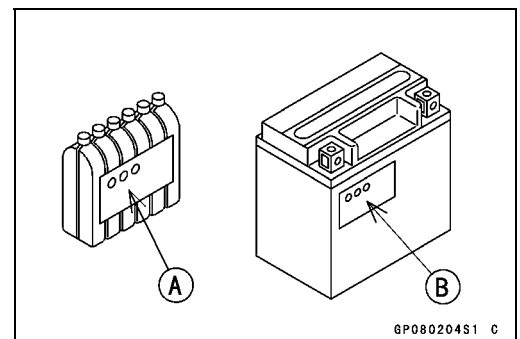

# 16-24 ELECTRICAL SYSTEM

## Battery

### CAUTION

Do not remove the aluminum sealing sheet [A] from the filler ports [B] until just prior to use. Be sure to use the dedicated electrolyte container for correct electrolyte volume.

- Place the battery on a level surface.
- Check to see that the sealing sheet has no peeling, tears, or holes in it.
- Remove the sealing sheet.

### NOTE

○The battery is vacuum sealed. If the sealing sheet has leaked air into the battery, it may require a longer initial charge.

- Remove the electrolyte container from the vinyl bag.
- Detach the strip of caps [A] from the container and set aside, these will be used later to seal the battery.

### NOTE

○Do not pierce or otherwise open the sealed cells [B] of the electrolyte container. Do not attempt to separate individual cells.

- Place the electrolyte container upside down with the six sealed cells into the filler ports of the battery. Hold the container level, push down to break the seals of all six cells. You will see air bubbles rising into each cell as the ports fill.

### NOTE

○Do not tilt the electrolyte container

- Check the electrolyte flow.
- ★If no air bubbles [A] are coming up from the filler ports, or if the container cells have not emptied completely, tap the container [B] a few times.
- Keep the container in place for **20** minutes or more. Don't remove the container from the battery until it's empty, the battery requires all the electrolyte from the container for proper operation.

### CAUTION

Removal of the container before it is completely empty can shorten the service life of the battery. Do not remove the electrolyte container until it is completely empty and 20 minutes have elapsed.

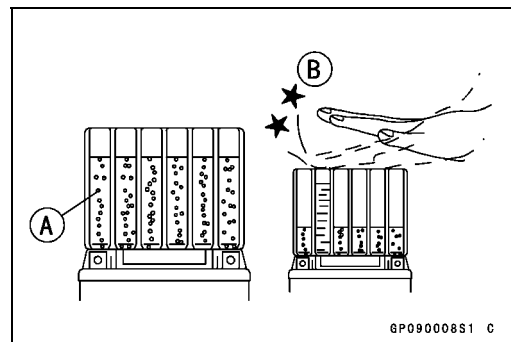
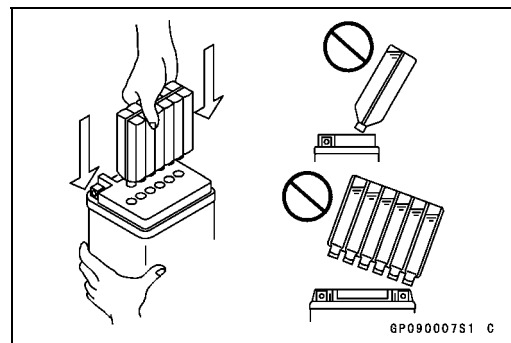
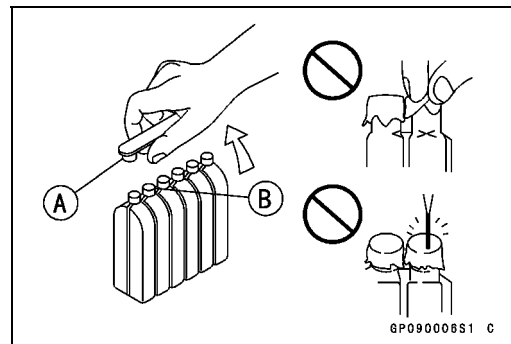
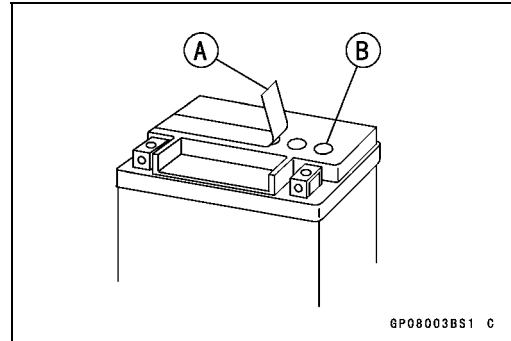

## Battery

- Gently remove the container from the battery.
- Let the battery sit for **30** minutes prior to charging to allow the electrolyte to permeate into the plates for optimum performance.

### NOTE

○ *Charging the battery immediately after filling can shorten service life. Let the battery sit for at least 30 minutes after filling.*

### Initial Charge

- Place the strip [A] of caps loosely over the filler ports.
- Newly activated sealed batteries require an initial charge.

**Standard Charge: 0.9 A × 5 ~ 10 hours**

- ★ If using a recommended battery charger, follow the charger's instructions for newly activated sealed battery.

#### Kawasaki-recommended chargers

**Optimate III**

**Yuasa 1.5 Amp Automatic Charger**

**Battery Mate 150-9**

- ★ If the above chargers are not available, use equivalent one.

### NOTE

○ *Charging rates will vary depending on how long the battery has been stored, temperature, and the type of charger used. Let battery sit 30 minutes after initial charge, then check voltage using a voltmeter. If it is not at least 12.8 V, repeat charging cycle.*

- After charging is completed, press down firmly with both hands to seat the strip of caps [A] into the battery (don't pound or hammer). When properly installed, the strip of the caps will be level with the top of the battery.

### CAUTION

**Once the strip of the caps [A] is installed onto the battery, never remove the caps, nor add water or electrolyte to the battery.**

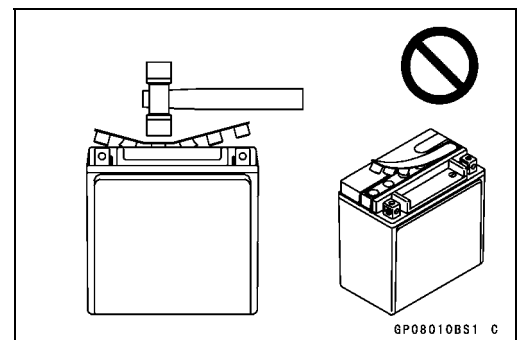
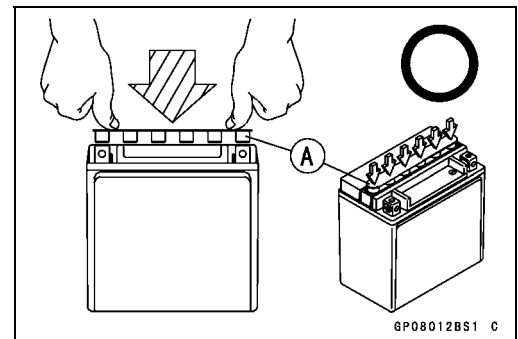
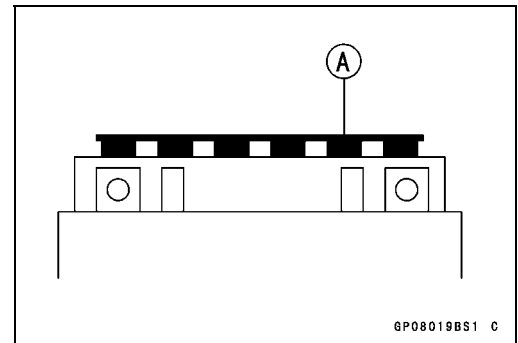

## 16-26 ELECTRICAL SYSTEM

### Battery

#### NOTE

- To ensure maximum battery life and customer satisfaction, it is recommended the battery be load tested at three times its amp-hour rating for 15 seconds. Re-check voltage and if less than 12.8 V repeat the charging cycle and load test. If still below 12.8 V the battery is defective.

#### Precautions

- 1) No need of topping-up

No topping-up is necessary in this battery until it ends its life under normal use. Forcibly prying off the seal cap to add water is very dangerous. Never do that.

- 2) Refreshing charge.

If an engine will not start, a horn sounds weak, or lamps are dim, it indicates the battery has been discharged. Give refresh charge for 5 to 10 hours with charge current shown in the specification (see Specifications in this chapter).

When a fast charge is inevitably required, do it following precisely the maximum charge current and time conditions indicated on the battery.

#### CAUTION

**This battery is designed to sustain no unusual deterioration if refresh-charged according to the method specified above. However, the battery's performance may be reduced noticeably if charged under conditions other than given above. Never remove the seal cap during refresh charge.**

**If by chance an excessive amount of gas is generated due to overcharging, the relief valve releases the gas to keep the battery normal.**

- 3) When you do not use the motorcycle for months.

Give a refresh charge before you store the motorcycle and store it with the negative cable removed. Give a refresh charge **once a month** during storage.

- 4) Battery life.

If the battery will not start the engine even after several refresh charges, the battery has exceeded its useful life. Replace it (Provided, however, the vehicle's starting system has no problem).

#### ⚠ WARNING

**Keep the battery away from sparks and open flames during charging, since the battery gives off an explosive gas mixture of hydrogen and oxygen. When using a battery charger, connect the battery to the charger before turning on the charger.**

**This procedure prevents sparks at the battery terminals which could ignite any battery gases.**

**No fire should be drawn near the battery, or no terminals should have the tightening loosened.**

**The electrolyte contains sulfuric acid. Be careful not to have it touch your skin or eyes. If touched, wash it off with liberal amount of water. Get medical attention if severe.**

#### Interchange

A sealed battery can fully display its performance only when combined with a proper vehicle electric system. Therefore, replace a sealed battery only on a motorcycle which was originally equipped with a sealed battery.

Be careful, if a sealed battery is installed on a motorcycle which had an ordinary battery as original equipment, the sealed battery's life will be shortened.

**Battery**

*Charging Condition Inspection*

- Battery charging condition can be checked by measuring battery terminal voltage with a digital voltmeter [A].
- Remove:
  - Fuel Tank (see Fuel Tank Removal in the Fuel System (DFI) chapter)
  - Battery Cable Caps (see Battery Removal in this chapter)
- Disconnect the battery terminals.

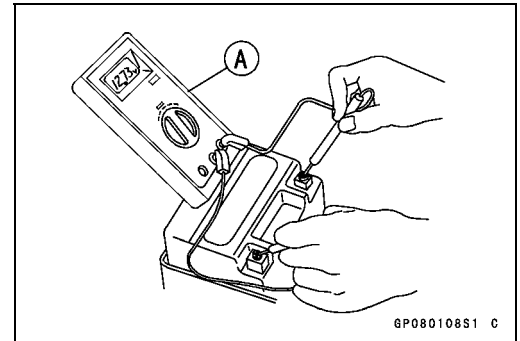

**CAUTION**

**Be sure to disconnect the negative (-) cable first.**

- Measure the battery terminal voltage.

**NOTE**

○ Measure with a digital voltmeter which can be read one decimal place voltage.

- ★ If the reading is 12.8 V or more, no refresh charge is required, however, if the read is below the specified, refresh charge is required.

**Battery Terminal Voltage**

**Standard: 12.8 V or more**

Terminal Voltage (V) [A]

Battery Charge Rate (%) [B]

Good [C]

Refresh charge is required [D]

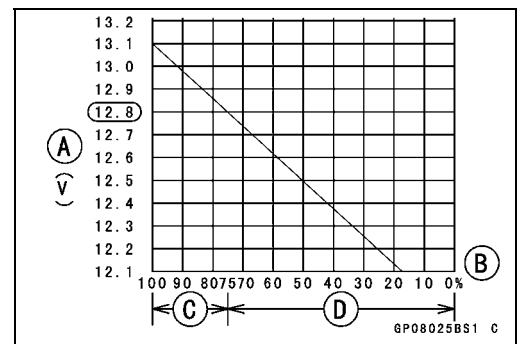

*Refreshing Charge*

- Remove the battery [A] (see Battery Removal in this chapter).
- Do refresh charge by following method according to the battery terminal voltage.

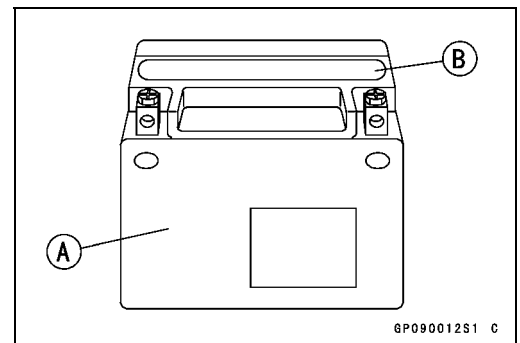

**⚠ WARNING**

**This battery is sealed type. Never remove sealing cap [B] even at charging. Never add water. Charge with current and time as stated below.**

# 16-28 ELECTRICAL SYSTEM

## Battery

Terminal Voltage: 11.5 ~ less than 12.8 V  
 Standard Charge 0.9 A × 5 ~ 10 h (see following chart)  
 Quick Charge 4 A × 1 h

### CAUTION

If possible, do not quick charge. If quick charge is done unavoidably, do standard charge later on.

Terminal Voltage: less than 11.5 V  
 Charging Method: 0.9 A × 20 h

### NOTE

○ Increase the charging voltage to a maximum voltage of 25 V if the battery will not accept current initially. Charge for no more than 5 minutes at the increased voltage then check if the battery is drawing current. If the battery will accept current decrease the voltage and charge by the standard charging method described on the battery case. If the battery will not accept current after 5 minutes, replace the battery.

Battery [A]  
 Battery Charger [B]  
 Standard Value [C]  
 Current starts to flow [D]

- Determine the battery condition after refresh charge.
- Determine the condition of the battery left for 30 minutes after completion of the charge by measuring the terminal voltage according to the table below.

Criteria	Judgement
12.8 V or higher	Good
12.0 ~ lower than 12.8 V	Charge insufficient → Recharge
lower than 12.0 V	Unserviceable → Replace

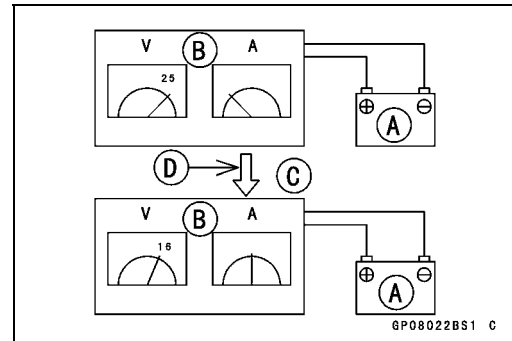
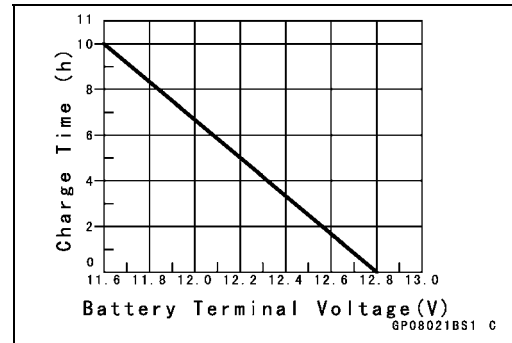

## Charging System

### Alternator Cover Removal

- Remove:
  - Left Center Fairing (see Center Fairing Removal in the Frame chapter)
  - Fuel Tank (see Fuel Tank Removal in the Fuel System (DFI) chapter)
  - Coolant Reserve Tank (see Coolant Reserve Tank Removal in the Cooling System chapter)
  - Alternator Lead Connector [A]

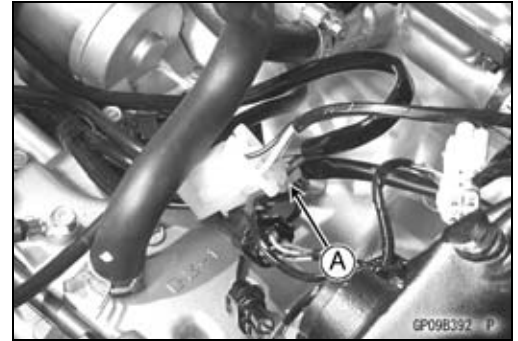

- Remove:
  - Bolts [A]
  - Cover [B]

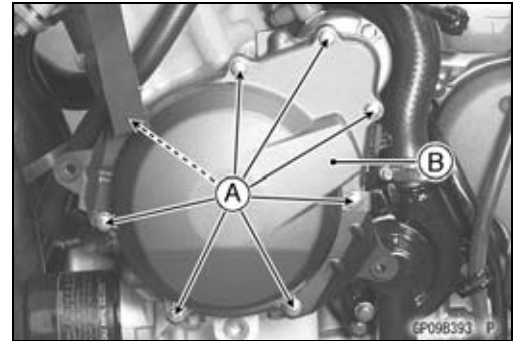

### Alternator Cover Installation

- Apply silicone sealant to the alternator lead grommet and crankcase halves mating surface [A] on the front and rear sides of the cover mount.

**Sealant - Kawasaki Bond (Silicone Sealant): 92104-0004**

- Check that dowel pins [B] are in place on the crankcase.
- Install a new gasket and the alternator cover.
- Tighten:

**Torque - Alternator Cover Bolts: 12 N·m (1.2 kgf·m, 104 in·lb)**

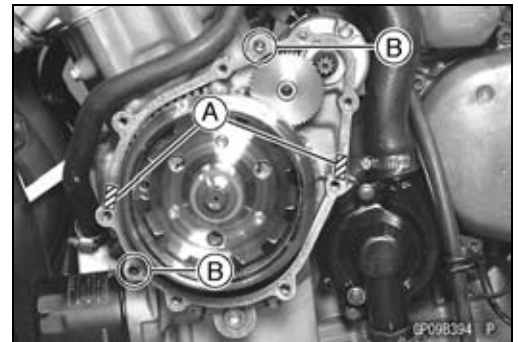

### Stator Coil Removal

- Remove:
  - Alternator Cover (see Alternator Cover Removal in this chapter)
  - Holding Plate Bolts [A] and Plate
  - Alternator Lead Grommet [B]
  - Stator Coil Bolts [C]
- Remove the stator coil [D] from the alternator cover.

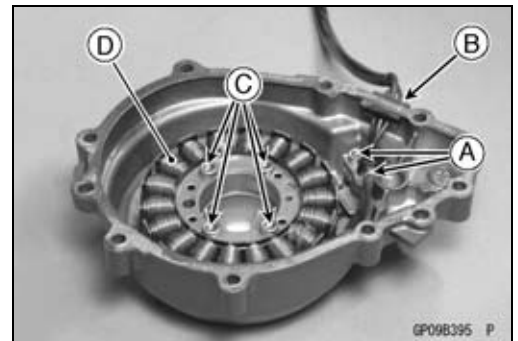

## 16-30 ELECTRICAL SYSTEM

### Charging System

#### Stator Coil Installation

- Apply a non-permanent locking agent to the threads of the stator coil bolts and tighten them.

**Torque - Stator Coil Bolts: 12 N·m (1.2 kgf·m, 104 in·lb)**

- Apply silicone sealant to the circumference of the alternator lead grommet, and fit the grommet into the notch of the cover securely.

**Sealant - Kawasaki Bond (Silicone Sealant): 92104-0004**

- Secure the alternator lead with a holding plate, and apply a non-permanent locking agent to the threads of the plate bolts and tighten them.

**Torque - Alternator Lead Holding Plate Bolts: 6.9 N·m (0.70 kgf·m, 61 in·lb)**

- Install the alternator cover (see Alternator Cover Installation in this chapter).

#### Alternator Rotor Removal

- Remove:
  - Alternator Cover (see Alternator Cover Removal in this section)
  - Starter Idle Gear and Shaft
- Wipe oil off the outer circumference of the rotor.
- Hold the alternator rotor steady with the flywheel holder [A], and remove the rotor bolt [B].

**Special Tool - Flywheel Holder: 57001-1313**

- Using the flywheel puller [A], remove the alternator rotor from the crankshaft.

**Special Tool - Flywheel Puller, M38 × 1.5: 57001-1405**

#### CAUTION

**Do not attempt to strike the alternator rotor itself. Striking the rotor can cause the magnets to lose their magnetism.**

#### Alternator Rotor Installation

- Using a cleaning fluid, clean off any oil or dirt on the following portions and dry them with a clean cloth.
  - Crankshaft Tapered Portion [A]
  - Alternator Rotor Tapered Portion [B]
- Apply a thin coat of molybdenum disulfide grease to the crankshaft [C].

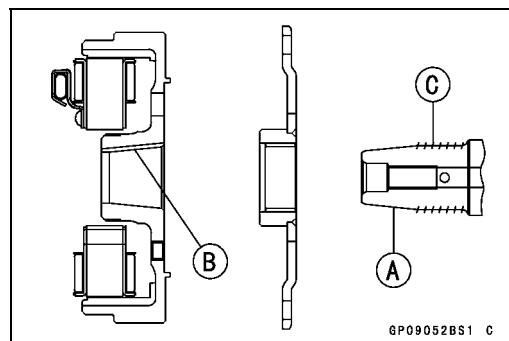
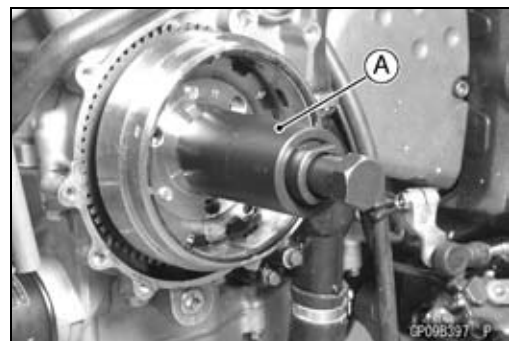
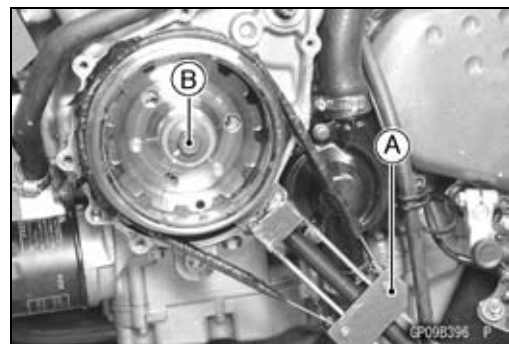

## Charging System

- Install the starter gear [A] and washer [B].
- Again, clean the crankshaft tapered portion [C] and dry there.

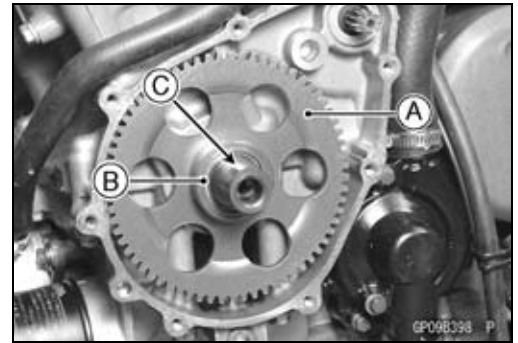

- Install the alternator rotor [A] while turning [B] it counter-clockwise.

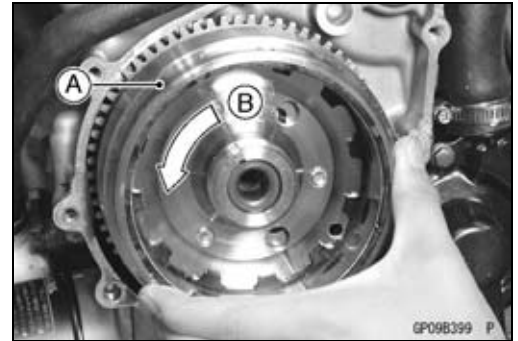

- Install the washer [A].

### NOTE

○ Confirm the alternator rotor fit or not to the crankshaft before tightening it with specified torque.

- Install the rotor bolt [B] and tighten it with 70 N·m (7.0 kgf·m, 52 ft·lb) of torque.
- Remove the rotor bolt.
- Check the tightening torque with flywheel puller [C].
- ★ If the rotor is not pulled out with 40 N·m (4.1 kgf·m, 30 ft·lb) of drawing torque, it is installed correctly.
- ★ If the rotor is pulled out with under 40 N·m (4.1 kgf·m, 30 ft·lb) of drawing torque, clean off any oil dirt or flaw of the crankshaft and rotor tapered portion, and dry them with a clean cloth. Then, confirm that it is not pulled out with above torque.
- Tighten the alternator rotor bolt while holding the alternator rotor steadily with the flywheel holder.

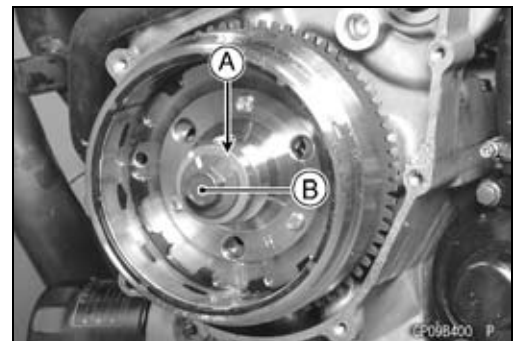

**Special Tool - Flywheel Holder: 57001-1313**

**Torque - Alternator Rotor Bolt: 110 N·m (11 kgf·m, 81 ft·lb)**

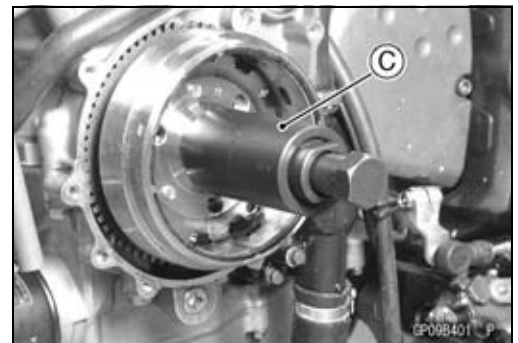

- Apply a thin coat of molybdenum disulfide grease to the shaft [A], and install it and starter idle gear [B].
- Install the alternator cover (see Alternator Cover Installation in this chapter).

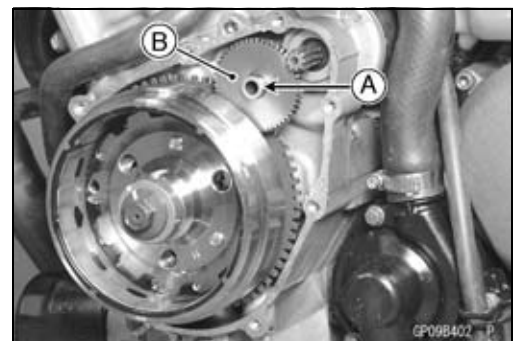

## 16-32 ELECTRICAL SYSTEM

### Charging System

#### Alternator Inspection

There are three types of alternator failures: short, open (wire burned out), or loss in rotor magnetism. A short or open in one of the coil wires will result in either a low output, or no output at all. A loss in rotor magnetism, which may be caused by dropping or hitting the alternator, by leaving it near an electromagnetic field, or just by aging, will result in low output.

- To check the alternator output voltage, do the following procedures.
  - Turn off the ignition switch.
  - Remove the fuel tank (see Fuel Tank Removal in the Fuel System (DFI) chapter).
  - Disconnect the alternator lead connector [A].
  - Connect the hand tester as shown in the table 1.
  - Start the engine.
  - Run it at the rpm given in the table 1.
  - Note the voltage readings (total 3 measurements).

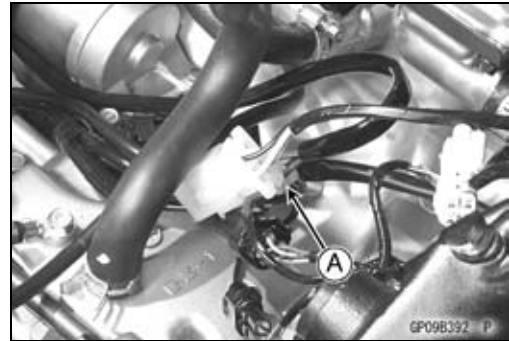

**Table 1 Alternator Output Voltage**

Tester Range	Connections		Reading @4 000 rpm
	Tester (+) to	Tester (-) to	
250 V AC	One Black lead	Another Black lead	42 V or more

- ★ If the output voltage shows the value in the table, the alternator operates properly.
- ★ If the output voltage shows a much higher than the value in the table, the regulator/rectifier is damaged. A much lower reading than that given in the table indicates that the alternator is defective.
- Check the stator coil resistance as follows.
  - Stop the engine.
  - Connect the commercially available tester as shown in the table 2.
  - Note the readings (total 3 measurement).

**Table 2 Stator Coil Resistance**

Tester Range	Connections		Reading
	Tester (+) to	Tester (-) to	
$\times 1 \Omega$	One Black lead	Another Black lead	0.3 ~ 0.4 $\Omega$

- ★ If there is more resistance than shown in the table, or no tester reading (infinity) for any two leads, the stator has an open lead and must be replaced. Much less than this resistance means the stator is shorted, and must be replaced.
- Using the highest resistance range of the hand tester, measure the resistance between each of the black leads and chassis ground.
- ★ Any hand tester reading less than infinity ( $\infty$ ) indicates a short, necessitating stator replacement.
- ★ If the stator coils have normal resistance, but the voltage check showed the alternator to be defective; then the rotor magnets have probably weakened, and the rotor must be replaced.

**Special Tool - Hand Tester: 57001-1394**

## Charging System

### Regulator/Rectifier Removal

- Remove:
  - Bolts [A]
  - Regulator/Rectifier [B]
  
- Remove:
  - Fuel Tank (see Fuel Tank Removal in the Fuel System (DFI) chapter)
  - Connector [A]

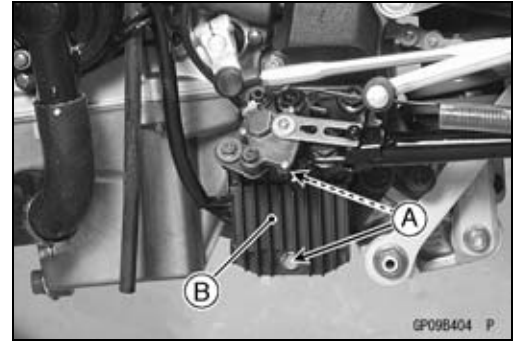

### Regulator/Rectifier Inspection

#### Rectifier Circuit Check

- Check the rectifier resistance as follows.
  - Disconnect the regulator/rectifier connector.
  - Connect the hand tester (special tool) to the regulator/rectifier as shown in the table, and check the resistance in both directions of each diode in the rectifier following the table.
- ★ The resistance should be low in one direction and more than ten times as much in the other direction. If any two leads are low or high in both directions, the rectifier is defective and the regulator/rectifier must be replaced.

#### NOTE

○ The actual meter reading varies with the meter used and the individual rectifier, but, generally speaking the lower reading should be from zero to one half the scale.

No.	Connections		Reading	Tester Range
	Tester (+)	Tester (-)		
1	BK1	BK/BL	∞	× 10 Ω or × 100 Ω
2	BK2			
3	BK3			
4	BK1	BK/W	1/2 scale or less	
5	BK2			
6	BK3			
7	BK/BL	BK1	∞	
8		BK2		
9		BK3		
10	BK/W	BK1	∞	
11		BK2		
12		BK3		

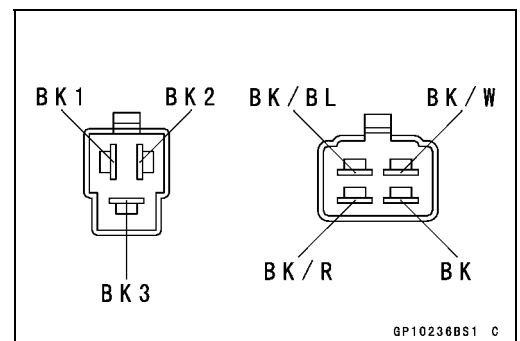

# 16-34 ELECTRICAL SYSTEM

## Charging System

### Regulator Circuit Check

To test the regulator out of circuit, use three 12 V batteries and a test light (12 V 3 ~ 6 W bulb in a socket with leads).

#### CAUTION

**The test light works as an indicator and also a current limiter to protect the regulator/rectifier from excessive current. Do not use an ammeter instead of a test light.**

- Do the 1st step regulator circuit test.
- Connect the test light and the 12 V battery to the regulator/rectifier as shown.
- Check BK1, BK2, and BK3 terminal respectively.
- ★ If the test light turns on, the regulator/rectifier is defective. Replace it.
- ★ If the test light does not turn on, continue the test.

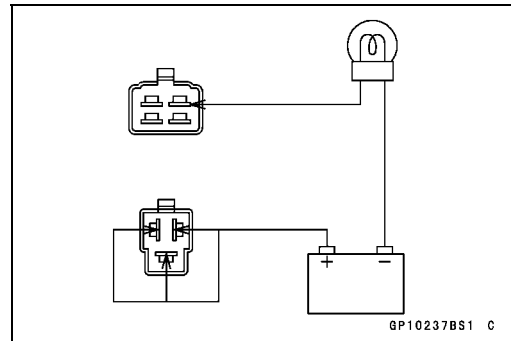

- Do the 2nd step regulator circuit test.
- Connect the test light and the 12 V battery in the same manner as specified in the "1st step regulator circuit test".
- Apply 12 V to the BK/R terminal.
- Check BK1, BK2, and BK3 terminal respectively.
- ★ If the test light turns on, the regulator/rectifier is defective. Replace it.
- ★ If the test light does not turn on, continue the test.

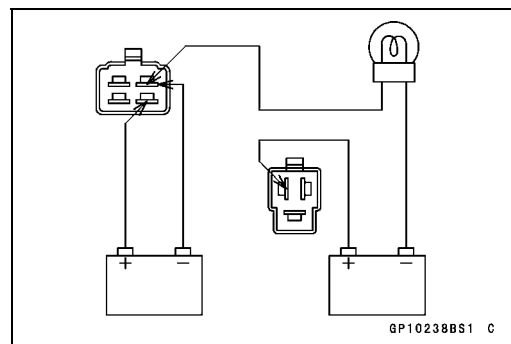

- Do the 3rd step regulator circuit test.
- Connect the test light and the 12 V battery in the same manner as specified in the "1st step regulator circuit test".
- Momentarily apply 24 V to the BK/R terminal by adding a 12 V battery.
- Check BK1, BK2, and BK3 terminals respectively.

#### CAUTION

**Do not apply more than 24 volts. If more than 24 volts is applied the regulator/rectifier may be damaged. Do not apply 24 V more than a few seconds. If 24 volts is applied for more than a few seconds, the regulator/rectifier may be damaged.**

- ★ If the test light did not light when the 24 V was applied momentarily to the BK/R terminal, the regulator/rectifier is defective. Replace it.
- ★ If the regulator/rectifier passes all of the tests described, it may still be defective. If the charging system still does not work properly after checking all of the components and the battery, test the regulator/rectifier by replacing it with a known good unit.

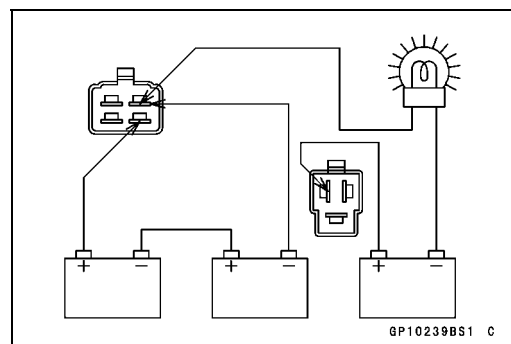

## Charging System

### Charging Voltage Inspection

- Check the battery condition (see Charging Condition Inspection in this chapter).
- Warm up the engine to obtain actual alternator operating conditions.
- Remove:
  - Front Seat (see Front Seat Removal in the Frame chapter)
  - Caps
- Check that the ignition switch is turned off, and connect the hand tester [A] as shown in the table.

**Special Tool - Hand Tester: 57001-1394**

- Start the engine, and note the voltage readings at various engine speeds with the headlight turned on and then turned off. (Disconnect the headlight connector in the upper fairing.) The readings should show nearly battery voltage when the engine speed is low, and, as the engine speed rises, the readings should also rise. But they must be kept under the specified voltage.



### Charging Voltage

Tester Range	Connections		Reading
	Tester (+) to	Tester (-) to	
25 V DC	Battery (+)	Battery (-)	14.2 ~ 15.2 V

- Turn off the ignition switch to stop the engine, and disconnect the hand tester.
- ★ If the charging voltage is kept between the values given in the table, the charging system is considered to be working normally.
- ★ If the charging voltage is much higher than the values specified in the table, the regulator/rectifier is defective or the regulator/rectifier leads are loose or open.
- ★ If the charging voltage does not rise as the engine speed increases, then the regulator/rectifier is defective or the alternator output is insufficient for the loads. Check the alternator and regulator/rectifier to determine which part is defective.

# 16-36 ELECTRICAL SYSTEM

## Charging System

### Charging System Circuit

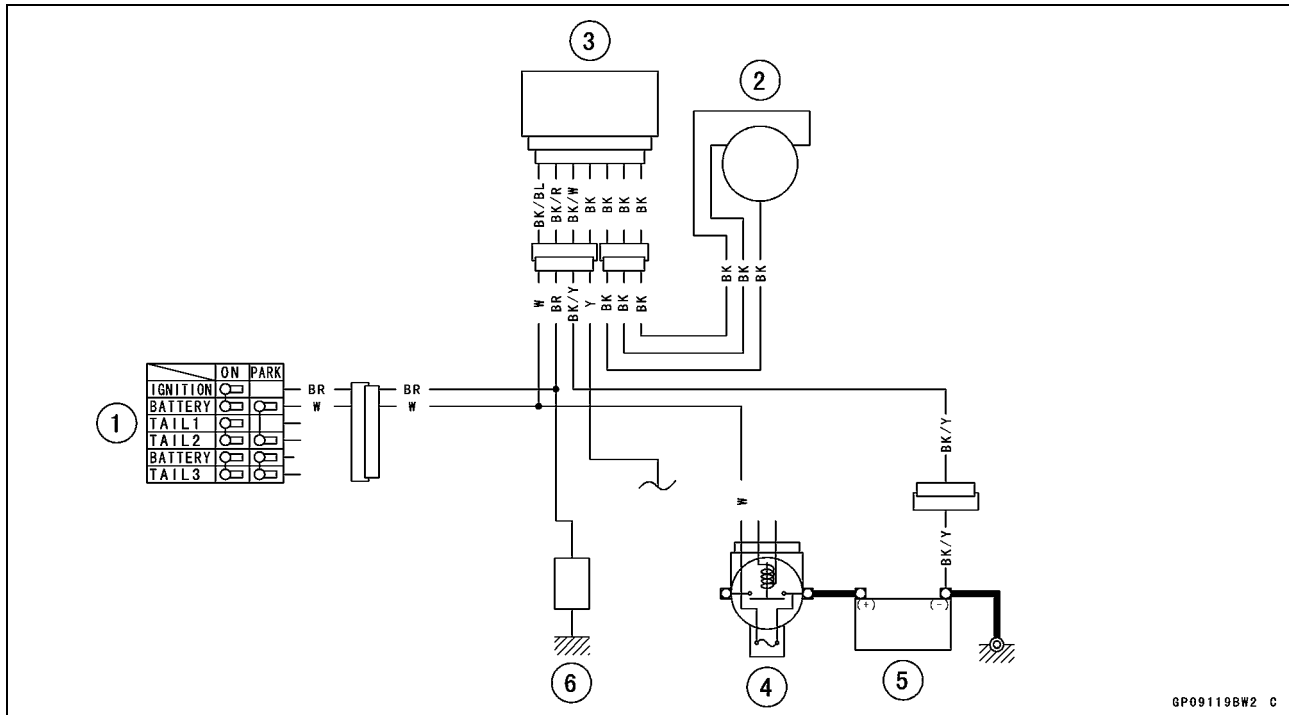

GP091198W2 C

1. Ignition Switch
2. Alternator
3. Regulator/rectifier
4. Main Fuse 30 A
5. Battery 12 V 8 Ah
6. Load

## Starter Motor Clutch

### Starter Motor Clutch Removal/Inspection

- Refer to the Alternator Rotor Removal and Installation in this chapter.

### Starter Motor Clutch Inspection

- Remove:
  - Alternator Cover (see Alternator Cover Removal in this chapter)
  - Starter Idle Gear
- Turn the starter motor clutch gear [A] by hand. The starter motor clutch gear should turn clockwise [B] freely, but should not turn counterclockwise [C].
- ★ If the starter motor clutch does not operate as it should or if it makes noise, go to the next step.
- Disassemble the starter motor clutch, and visually inspect the clutch parts.
- ★ If there is any worn or damaged part, replace it.

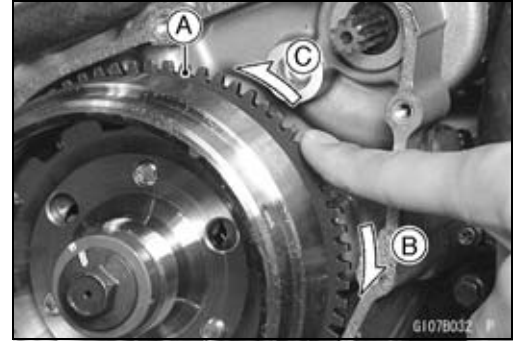

### NOTE

○ Examine the starter motor clutch gear as well. Replace it if it is worn or damaged.

### Starter Motor Clutch Disassembly

- Remove:
  - Alternator Rotor (see Alternator Rotor Removal in this chapter)
  - Starter Motor Clutch Bolts [A]
  - Starter Motor Clutch [B]

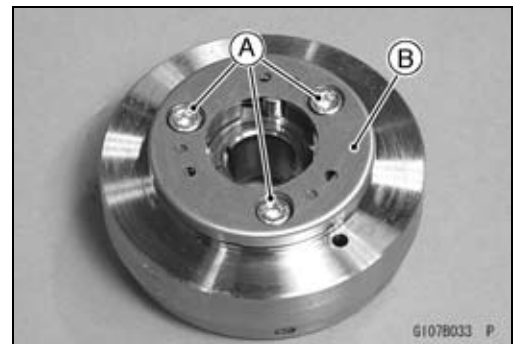

### Starter Motor Clutch Assembly

- Apply a non-permanent locking agent to the threads of the starter motor clutch bolts and tighten them.
- Torque - Starter Motor Clutch Bolts: 34 N·m (3.5 kgf·m, 25 ft·lb)**

# 16-38 ELECTRICAL SYSTEM

## Ignition System

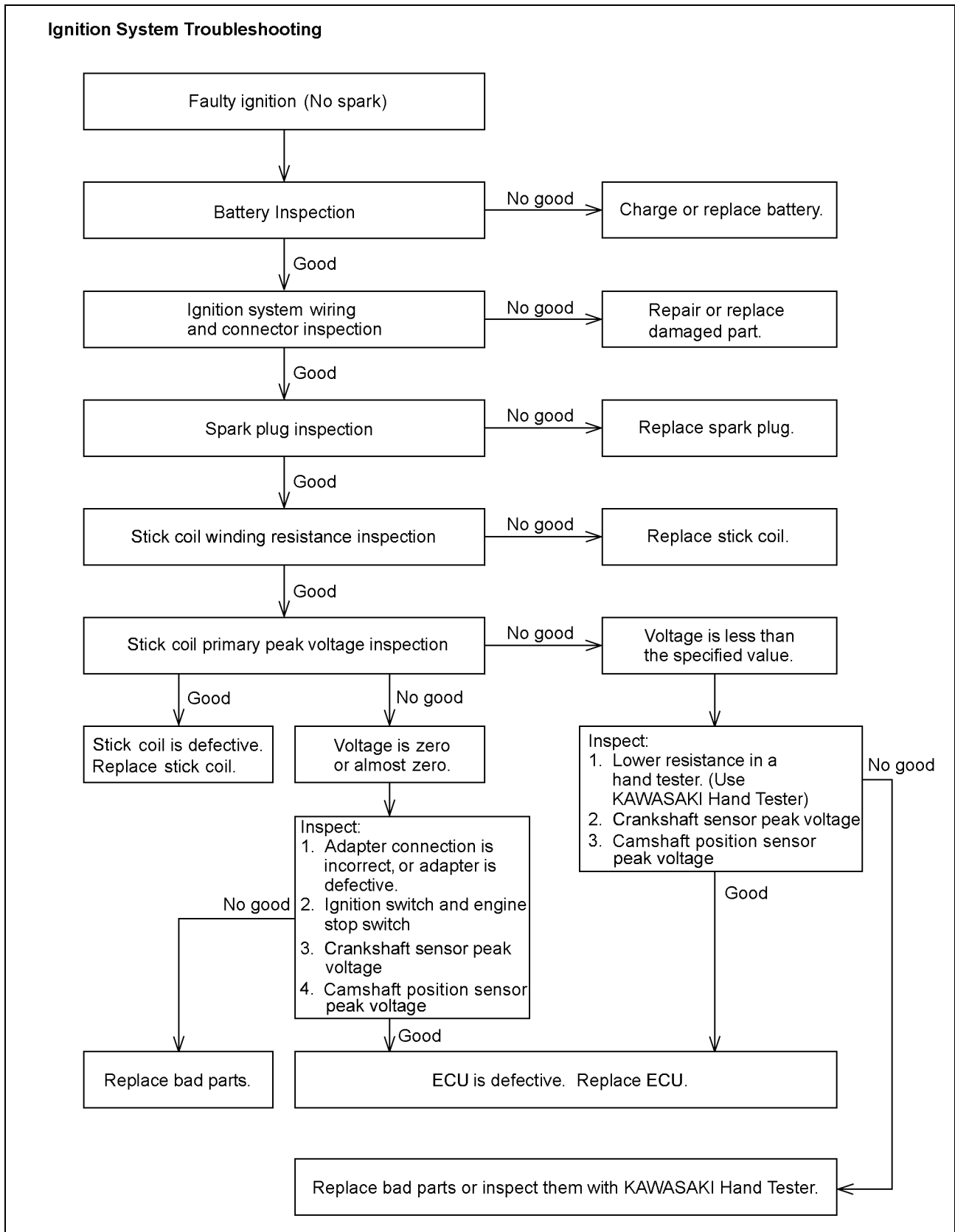

## Ignition System

### **⚠ WARNING**

The ignition system produces extremely high voltage. Do not touch the spark plugs or stick coils while the engine is running, or you could receive a severe electrical shock.

### **CAUTION**

Do not disconnect the battery leads or any other electrical connections when the ignition switch is on, or while the engine is running. This is to prevent IC igniter damage.

Do not install the battery backwards. The negative side is grounded. This is to prevent damage to the diodes and IC igniter.

### *Crankshaft Sensor Removal*

- Remove:
  - Fuel Tank (see Fuel Tank Removal in the Fuel System (DFI) chapter)
  - Right Center Fairing (see Center Fairing Removal in the Frame chapter)
  - Crankshaft Sensor Lead Connector [A]
  
- Remove:
  - Bolts [A]
  - Crankshaft Sensor Cover [B]
  - Oil Pressure Switch Terminal [C]
  - Neutral Switch Lead Connector
  
- Remove:
  - Bolts [A]
  - Crankshaft Sensor [B]
- Pull out the grommet [C].

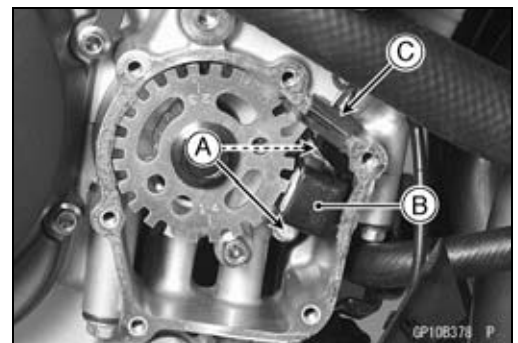
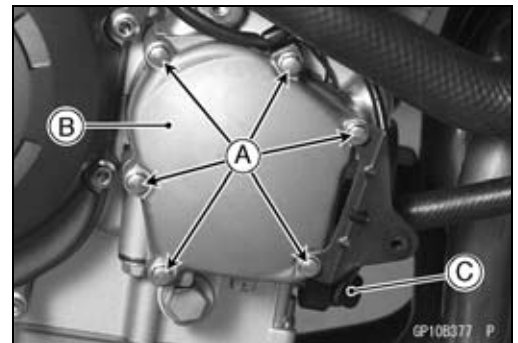

## 16-40 ELECTRICAL SYSTEM

### Ignition System

#### *Crankshaft Sensor Installation*

- Route the crankshaft sensor lead correctly (see Cable, Wire, and Hose Routing section in the Appendix chapter).
- Tighten:
  - Torque - Crankshaft Sensor Bolts: 5.9 N·m (0.60 kgf·m, 52 in·lb)**
- Apply silicone sealant.
  - Crankshaft Sensor Lead Grommet (Around) [A]
  - Crankcase Halves Mating Surfaces [B]
  - Sealant - Kawasaki Bond (Silicone Sealant): 92104-0004**
- Install the gasket.
- Apply a non-permanent locking agent.
  - Crankshaft Sensor Cover Bolt [A]
- Install the bolt with clamp [B].
- Tighten:
  - Torque - Crankshaft Sensor Cover Bolts: 9.8 N·m (1.0 kgf·m, 87 in·lb)**
- Connect sensor lead connector.
- Install the removed parts (see appropriate chapters).

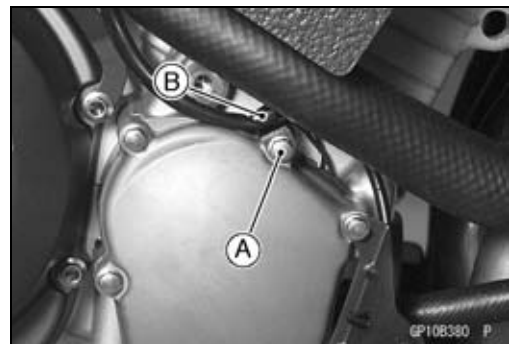
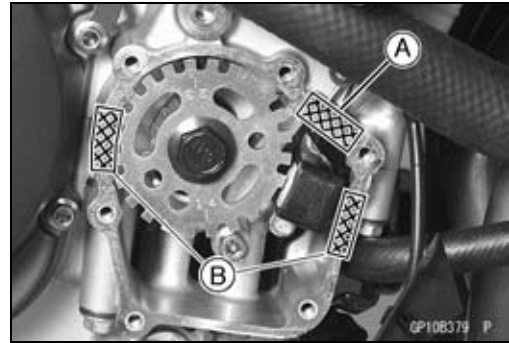

#### *Crankshaft Sensor Inspection*

- Remove:
  - Crankshaft Sensor Lead Connector (see Crankshaft Sensor Removal in this chapter)
- Set the hand tester [A] to the  $\times 100 \Omega$  range and connect the (+) lead to the black lead and (-) lead to the black/yellow lead in the connector [B].
- Special Tool - Hand Tester: 57001-1394**
- ★ If there is more resistance than the specified value, the coil has an open lead and must be replaced. Much less than this resistance means the coil is shorted, and must be replaced.

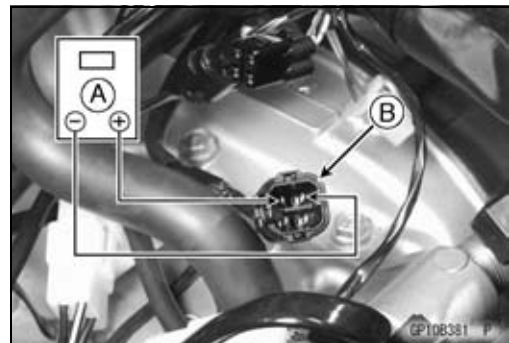

#### **Crankshaft Sensor Resistance: 380 ~ 570 $\Omega$**

- Using the highest resistance range of the tester, measure the resistance between the crankshaft sensor leads and chassis ground.
- ★ Any tester reading less than infinity ( $\infty$ ) indicates a short, necessitating replacement of the crankshaft sensor assembly.

#### *Crankshaft Sensor Peak Voltage*

##### **NOTE**

- Be sure the battery is fully charged.
- Using the peak voltage adapter is a more reliable way to determine the condition of the crankshaft sensor than crankshaft sensor internal resistance measurements.

- Remove:
  - Crankshaft Sensor Lead Connector (see Crankshaft Sensor Removal in this chapter)

## Ignition System

- Set the hand tester [A] to the  $\times 10$  V DC range, and connect it peak voltage adapter [B].
- Connect the black lead (-) [D] of the adapter to black/yellow lead and red lead (+) [C] to black lead in the crankshaft sensor connector [E].
- Turn the ignition switch on and engine stop switch on.

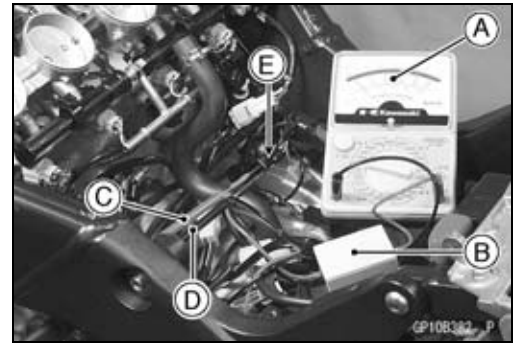

- Pushing the starter button, turn the engine 4 ~ 5 seconds with the transmission gear in neutral to measure the crankshaft sensor peak voltage.
- Repeat the measurement 5 or more times.

### Crankshaft Sensor Peak Voltage

**Standard: 3.2 V or more**

**Special Tools - Hand Tester: 57001-1394**

**Peak Voltage Adapter: 57001-1415**

**Type: KEK-54-9-B**

- ★ If the tester reading is not specified one, check the crankshaft sensor.

### Timing Rotor Removal

- Remove the crankshaft sensor (see Crankshaft Sensor Removal in this chapter).
- Remove the timing rotor [A].
- Holding the timing rotor with the flywheel and pulley holder [B] and unscrew the bolt [C].

**Special Tool - Flywheel and Pulley Holder: 57001-1605**

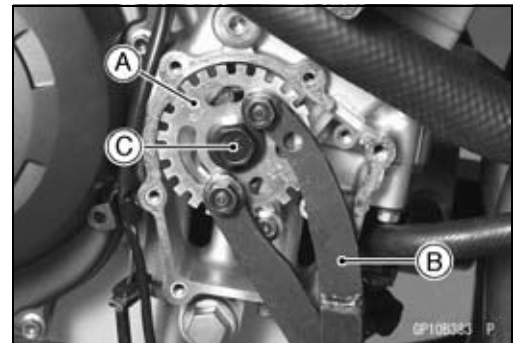

### Timing Rotor Installation

- Fit the rotor to the crankshaft.
- Tighten the rotor bolt.

**Torque - Timing Rotor Bolt: 45 N·m (4.5 kgf·m, 33 ft·lb)**

**Special Tool - Flywheel and Pulley Holder: 57001-1605**

- Install the crankshaft sensor (see Crankshaft Sensor Installation in this chapter).

### Stick Coil (Ignition Coil together with Spark Plug Cap) Removal

- Remove:
  - Air Cleaner Housing (see Air Cleaner Housing Removal in the Fuel System (DFI) chapter)
- Disconnect the stick coil connectors [A].
- Pull the stick coils [B] off the spark plugs.

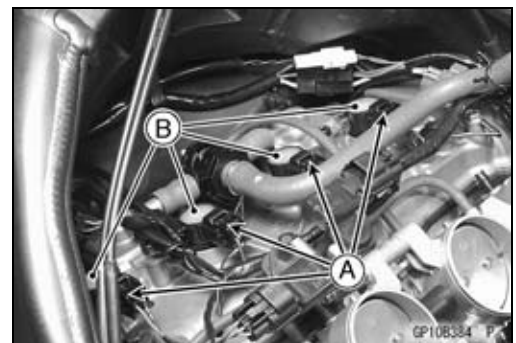

### CAUTION

**Do not pry the connector part of the coil while removing the coil.**

## 16-42 ELECTRICAL SYSTEM

### Ignition System

#### *Stick Coil (Ignition Coil together with Spark Plug Cap) Installation*

- Connect the connectors [A].

<b>CAUTION</b>
----------------

<b>Do not tap the coil head while installing the coil.</b>
--

- Run the hoses and harness correctly (see Cable, Wire, and Hose Routing section in the Appendix chapter).
- Install removed parts (see appropriate chapters).

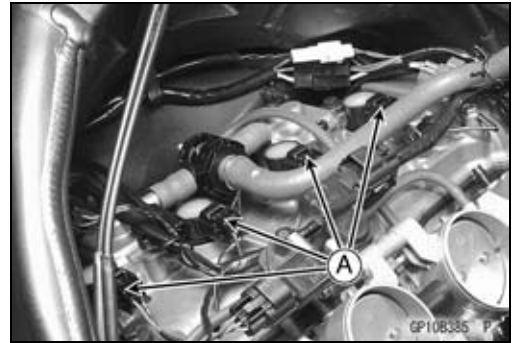

#### *Stick Coil (Ignition Coil together with Spark Plug Cap) Inspection*

- Remove the stick coils (see Stick Coil (Ignition Coil together with Spark Plug Cap) Removal in this chapter).
- Measure the primary winding resistance [A] as follows.
  - Connect the hand tester between the coil terminals.
  - Set the tester to the  $\times 1 \Omega$  range, and read the tester.
- Measure the secondary winding resistance [B] as follows.
  - Connect the tester between the plug terminal and (-) coil terminal.
  - Set the tester to the  $\times 1 \text{ k}\Omega$  range and read the tester.

#### **Ignition Coil Winding Resistance**

**Primary Windings: 1.2 ~ 1.6  $\Omega$**

**Secondary Windings: 8.5 ~ 11.5  $\text{k}\Omega$**

- ★ If the tester does not read as specified, replace the coil.

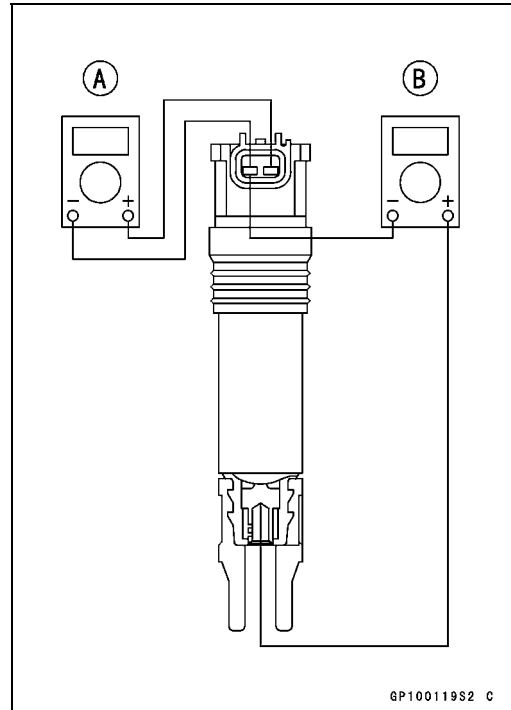

## Ignition System

### Stick Coil Primary Peak Voltage

#### NOTE

○ Be sure the battery is fully charged.

- Remove the stick coils (see Stick Coil (Ignition Coil together with Spark Plug Cap) Removal in this chapter), but do not remove the spark plugs.
- Measure the primary peak voltage as follows.
- Install the new spark plug [A] into each stick coil [B], and ground them onto the engine.
- Connect peak voltage adapter [C] into the hand tester [D] which is set to the  $\times 250$  V DC range.
- Connect the adapter to the lead wire-peak voltage adapter [E] which is connected between the stick coil connector and stick coil.

ECU [F]

**Special Tools - Hand Tester: 57001-1394**

**Peak Voltage Adapter: 57001-1415**

**Type: KEK-54-9-B**

**Lead Wire-Peak Voltage Adapter: 57001-1449**

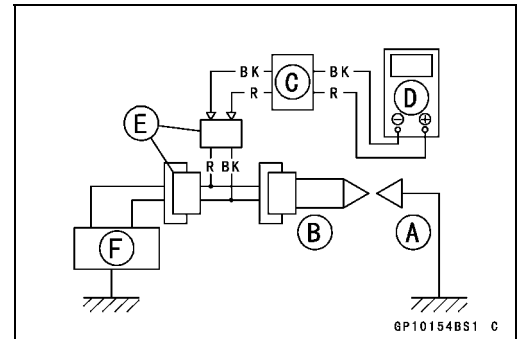

### Primary Lead Connection

**Adapter (R, +) to lead wire-peak voltage adapter:**

**Stick Coil #1 (BK)**

**Stick Coil #2 (BK/G)**

**Stick Coil #3 (BK/W)**

**Stick Coil #4 (BK/O)**

**Adapter (BK, -) to lead wire-peak voltage adapter (R)**

## ⚠ WARNING

**To avoid extremely high voltage shocks, do not touch the spark plugs or tester connections.**

- Turn the ignition switch and the engine stop switch ON.
- Pushing the starter button, turn the engine 4 ~ 5 seconds with the transmission in neutral to measure the primary peak voltage.
- Repeat the measurements 5 times for one stick coil.

### Stick Coil Primary Peak Voltage

**Standard: 100 V or more**

- Repeat the test for the other stick coil.
- ★ If the reading is less than the specified value, check the following.
  - Stick Coils (see Stick Coil (Ignition Coil together with Spark Plug Cap) Inspection in this chapter)
  - Crankshaft Sensor (see Crankshaft Sensor Inspection in this section)
  - ECU (see ECU Power Supply Inspection in the Fuel System (DFI) chapter)

### Spark Plug Removal

- Refer to the Spark Plug Replacement in the Periodic Maintenance chapter.

## 16-44 ELECTRICAL SYSTEM

### Ignition System

#### *Spark Plug Installation*

- Refer to the Spark Plug Replacement in the Periodic Maintenance chapter.

#### *Spark Plug Clean and Inspection*

- Refer to the Spark Plug Clean and Gap Inspection in the Periodic Maintenance chapter.

#### *Spark Plug Gap Inspection*

- Refer to the Spark Plug Clean and Gap Inspection in the Periodic Maintenance chapter.

#### *Camshaft Position Sensor Removal*

- Remove:
  - Right Center Fairing (see Center Fairing Removal in the Frame chapter)
  - Air Cleaner Housing (see Fuel System (DFI) chapter)
  - Connector [A]

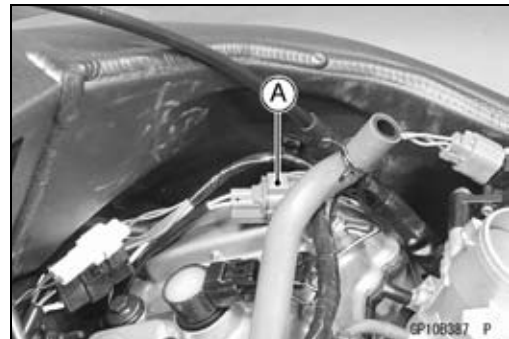

- Remove:
  - Camshaft Position Sensor Bolt [A]
  - Camshaft Position Sensor [B]

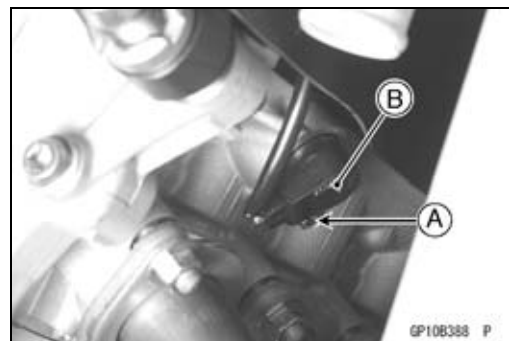

#### *Camshaft Position Sensor Installation*

- Apply high-temperature grease to the O-ring on the camshaft position sensor.
- Tighten:
  - Torque - Camshaft Position Sensor Bolt: 12 N·m (1.2 kgf·m, 104 in·lb)**

#### *Camshaft Position Sensor Inspection*

- Remove:
  - Camshaft Position Sensor Lead Connector [A] (see Camshaft Position Sensor Removal in this section)



## Ignition System

- Set the hand tester to the  $\times 10 \Omega$  range and connect it to the terminals.

**Special Tool - Hand Tester: 57001-1394**

- ★ If there is more resistance than the specified value, the sensor coil has an open lead and must be replaced. Much less than this resistance means the sensor coil is shorted, and must be replaced.

**Camshaft Position Sensor Resistance: 400 ~ 460  $\Omega$**

- Using the highest resistance range of the tester, measure the resistance between the camshaft position sensor leads and chassis ground.
- ★ Any tester reading less than infinity ( $\infty$ ) indicates a short, necessitating replacement of the camshaft position sensor.

### Camshaft Position Sensor Peak Voltage Inspection

- Remove:
  - Camshaft Position Sensor Lead Connector (see Camshaft Position Sensor Removal in this chapter)
- Set the hand tester [A] to the 10 V DC range.
- Connect commercially available peak voltage adapter [B] to the hand tester and camshaft position sensor leads in the terminals.

**Special Tool -**                      **Hand Taster: 57001-1394**  
    **Peak Voltage Adapter: 57001-1415**  
    **Type: KEK-54-9-B**

#### Connections:

Camshaft Position Sensor Terminal	Adapter	Hand Tester
White/Yellow [C]	← Red →	(-)
Yellow [D]	← Black →	(+)

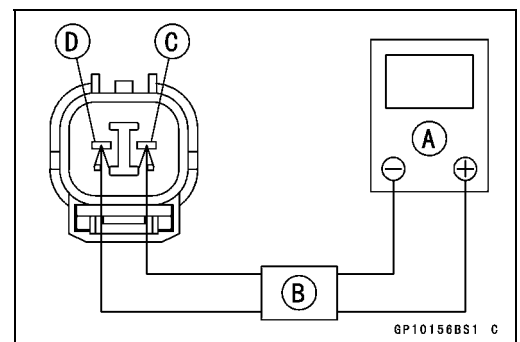
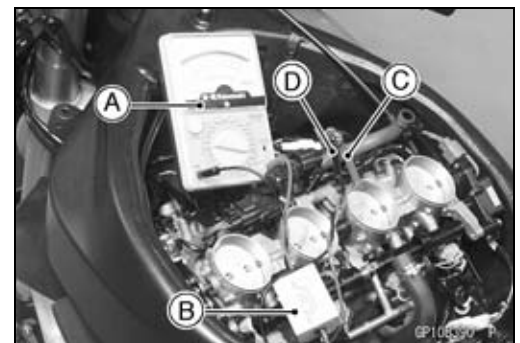
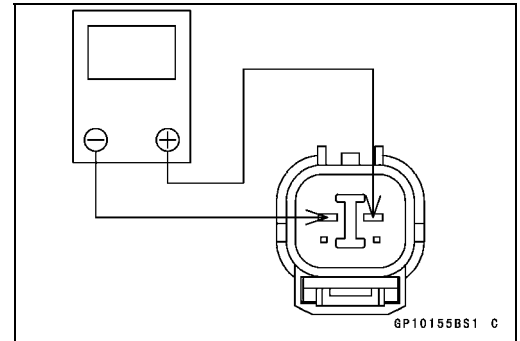

- Turn the ignition switch and engine stop switch on.
- Pushing the starter button, turn the engine 4 ~ 5 seconds with the transmission gear in neutral to measure the camshaft position sensor peak voltage.
- Repeat the measurement 5 or more times.

### Camshaft Position Sensor Peak Voltage

**Standard: 0.4 V or more**

- ★ If the peak voltage is lower than the standard, inspect the camshaft position sensor.

## 16-46 ELECTRICAL SYSTEM

### Ignition System

#### *Interlock Operation Inspection*

- Using the stand [A], raise the rear wheel off the ground.



#### **1st Check**

- Start the engine to the following conditions.

##### **Condition**

**Transmission Gear** → 1st Position

**Clutch Lever** → Release

**Side Stand** → Down or Up

- Turn the ignition switch ON and push the starter button.
- Then the starter motor should not turn when the starter system circuit is normality.
- ★ If the engine is start, inspect the starter lockout switch, neutral switch and relay box.
- ★ If their parts are normality replace the ECU.

#### **2nd Check**

- Start the engine to the following conditions.

##### **Condition**

**Transmission Gear** → 1st Position

**Clutch Lever** → Pulled in

**Side Stand** → Up

- Turn the ignition switch ON and push the starter button.
- Then the starter motor should turn when the starter system circuit is normality.
- ★ If the starter motor is not turn, inspect the starter lockout switch, neutral switch and relay box.
- ★ If their parts are normality replace the ECU.

#### **3rd Check**

- Inspect the engine for its secure stop after the following operations are completed.
- Run the engine to the following conditions.

##### **Condition**

**Transmission Gear** → 1st Position

**Clutch Lever** → Release

**Side Stand** → Up

- Set the side stand on the ground, then the engine will stop.
- ★ If whichever may not be stopped, inspect the gear position switch, starter lockout switch, side stand switch and relay box.
- ★ If their parts are normality, replace the ECU.

---

**Ignition System**

---

*IC Igniter Inspection*

- The IC igniter is built in the ECU [A].
- Refer to the Interlock Operation Inspection, Ignition System Troubleshooting chart and Fuel System (DFI) chapter for ECU Power Supply Inspection.

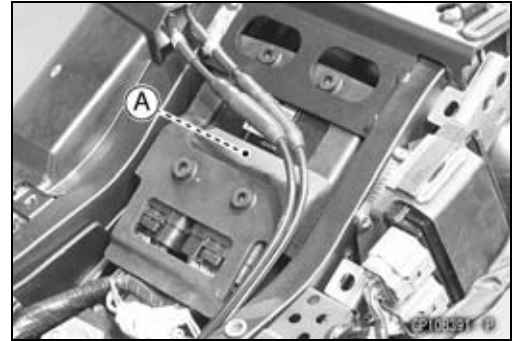

# 16-48 ELECTRICAL SYSTEM

## Ignition System

### Ignition System Circuit

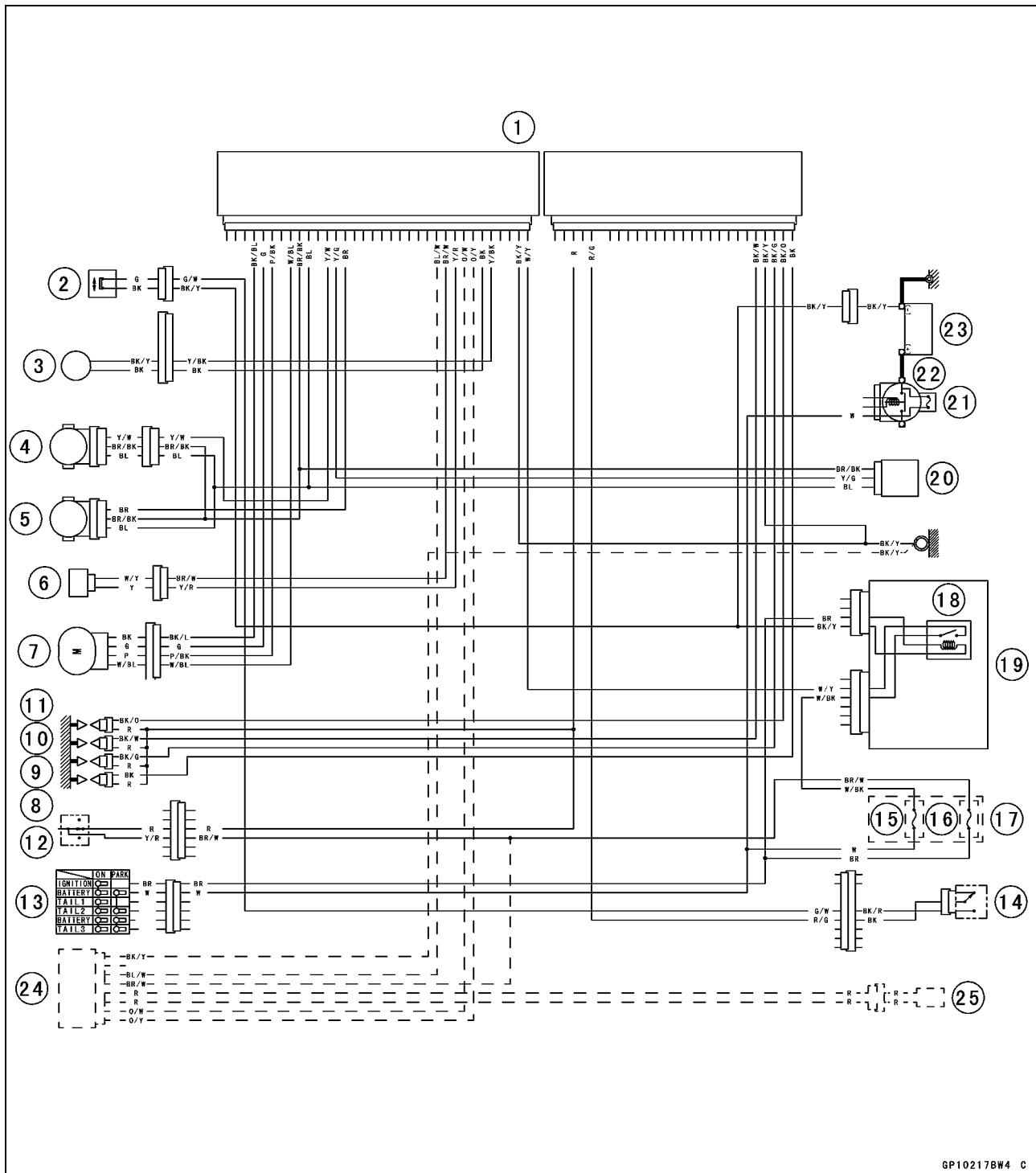

GP102178W4 C

- |                                     |                            |
|-------------------------------------|----------------------------|
| 1. ECU                              | 13. Ignition Switch        |
| 2. Side Stand Switch                | 14. Starter Lockout Switch |
| 3. Crankshaft Sensor                | 15. ECU Fuse 15 A          |
| 4. Main Throttle Sensor             | 16. Ignition Fuse 10 A     |
| 5. Subthrottle Sensor               | 17. Fuse Box               |
| 6. Camshaft Position Sensor         | 18. ECU Main Relay         |
| 7. Exhaust Butterfly Valve Actuator | 19. Relay Box              |
| 8. Stick Coil #1                    | 20. Vehicle-down Sensor    |
| 9. Stick Coil #2                    | 21. Starter Relay          |
| 10. Stick Coil #3                   | 22. Main Fuse 30 A         |
| 11. Stick Coil #4                   | 23. Battery 12 V 8 Ah      |
| 12. Engine Stop Switch              | 24. Immobilizer Amplifier  |
|                                     | 25. Immobilizer Antenna    |

## Electric Starter System

### Starter Motor Removal

- Remove the fuel tank (see Fuel Tank Removal in the Fuel System (DFI) chapter).
- Slide back the rubber cap.
- Remove the starter motor terminal bolt [A] and the mounting bolts [B].
- Pull out the starter motor [C].

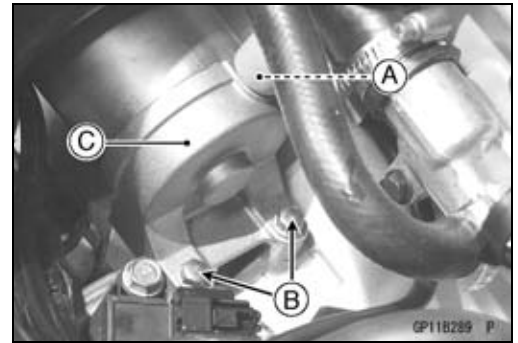

### Starter Motor Installation

#### CAUTION

**Do not tap the starter motor shaft or body. Tapping the shaft or body could damage the motor.**

- When installing the starter motor, clean the starter motor legs [A] and crankcase [B] where the starter motor is grounded.

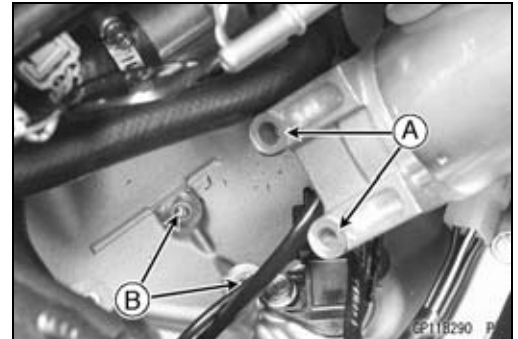

- Replace the O-ring [A] with a new one.
- Apply grease to the O-ring.
- Tighten:

**Torque - Starter Motor Mounting Bolts: 11 N·m (1.1 kgf·m, 97 in·lb)**

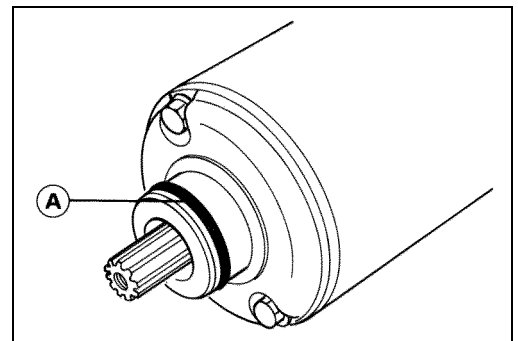

### Starter Motor Disassembly

- Take off the starter motor through bolts [A] and remove both end covers [B] and pull the armature out of the yoke [C].

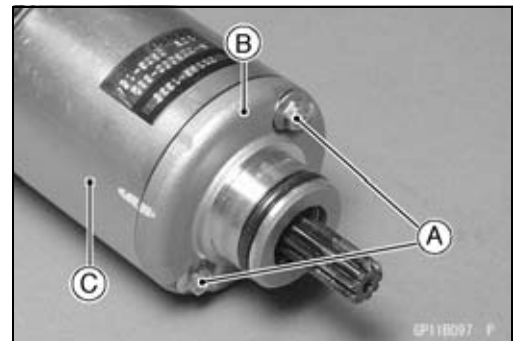

### Starter Motor Assembly

- Apply a thin coat of grease to the oil seal [A].
- Fit the toothed washer [B] into the left-hand end cover.
- Install the washer [C].

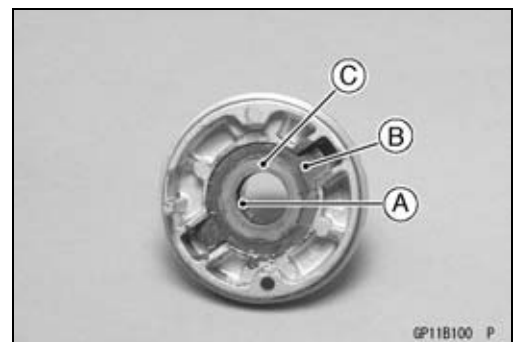

# 16-50 ELECTRICAL SYSTEM

## Electric Starter System

- Press the springs holding the brush leads with suitable clips [A] as shown.
- Put the armature [B] among the brushes.

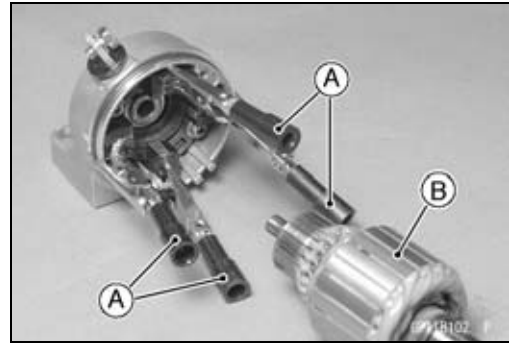

- Install the O-rings [A] as shown.

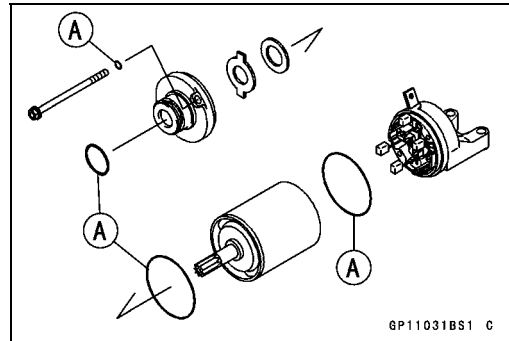

- Align the groove [A] in the right-hand end cover and the hollow mark [B] on the yoke.

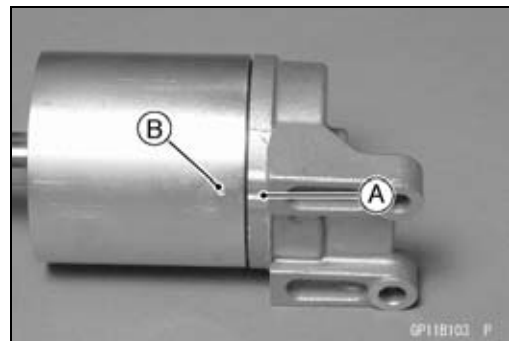

- Align the hollow mark [A] on the left-hand end cover and the hollow mark [B] on the yoke.

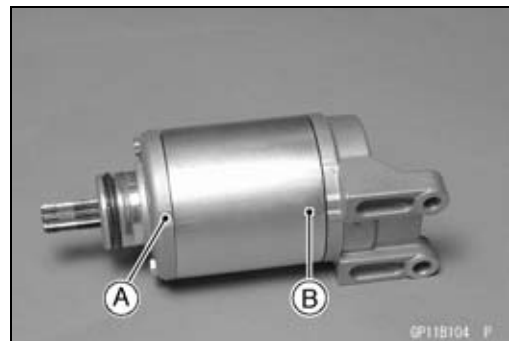

### Brush Inspection

- Measure the length [A] of each brush.
- ★ If any is worn down to the service limit, replace the brush holder assembly.

#### Starter Motor Brush Length

Standard: 7 mm (0.28 in.)

Service Limit: 3.5 mm (0.14 in.)

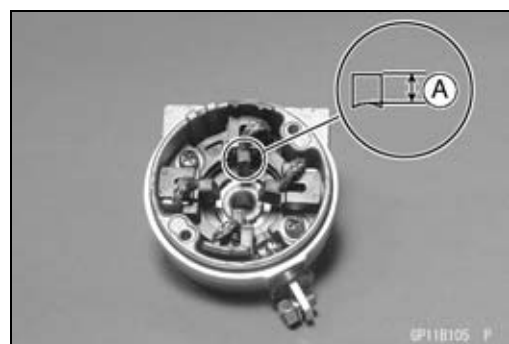

## Electric Starter System

### Commutator Cleaning and Inspection

- Smooth the commutator surface [A] if necessary with fine emery cloth [B], and clean out the grooves.

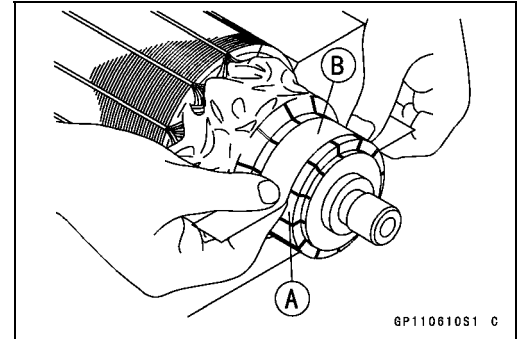

- Measure the diameter [A] of the commutator [B].
- ★ If the commutator diameter is less than the service limit, replace the starter motor with a new one .

#### Commutator Diameter

Standard: 24 mm (0.94 in.)

Service Limit: 23 mm (0.91 in.)

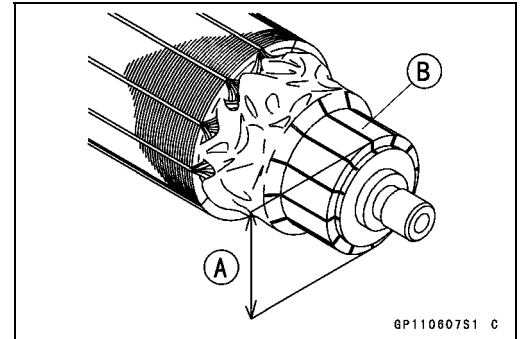

### Armature Inspection

- Using the  $\times 1 \Omega$  hand tester range, measure the resistance between any two commutator segments [A].

#### Special Tool - Hand Tester: 57001-1394

- ★ If there is a high resistance or no reading ( $\infty$ ) between any two segments, a winding is open and the starter motor must be replaced.
- Using the highest hand tester range, measure the resistance between the segments and the shaft [B].
- ★ If there is any reading at all, the armature has a short and the starter motor must be replaced.

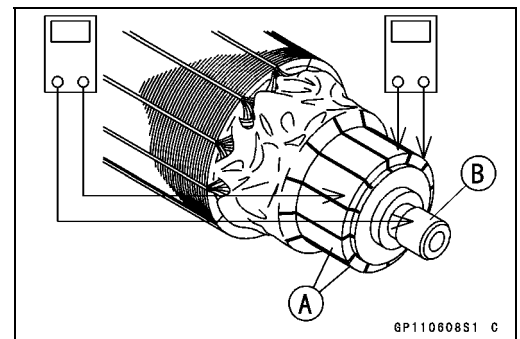

### NOTE

○ Even if the foregoing checks show the armature to be good, it may be defective in some manner not readily detectable with the hand tester. If all other starter motor and starter motor circuit components check good, but the starter motor still does not turn over or only turns over weakly, replace the starter motor with a new one.

### Brush Lead Inspection

- Using the  $\times 1 \Omega$  hand tester range, measure the resistance as shown.

Terminal Bolt and Positive Brush [A]

Right-hand End Cover and Negative Brush [B]

#### Special Tool - Hand Tester: 57001-1394

- ★ If there is not close to zero ohms, the brush lead has an open. Replace the positive brush assembly and/or the negative brush subassembly.

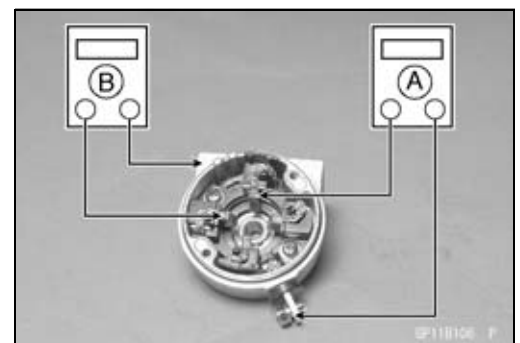

# 16-52 ELECTRICAL SYSTEM

## Electric Starter System

### Right-hand End Cover Assembly Inspection

- Using the highest hand tester range, measure the resistance as shown.

Terminal and Right-hand End Cover [A]

**Special Tool - Hand Tester: 57001-1394**

- ★ If there is any reading, the right-hand end cover assembly have a short. Replace the right-hand end cover assembly.

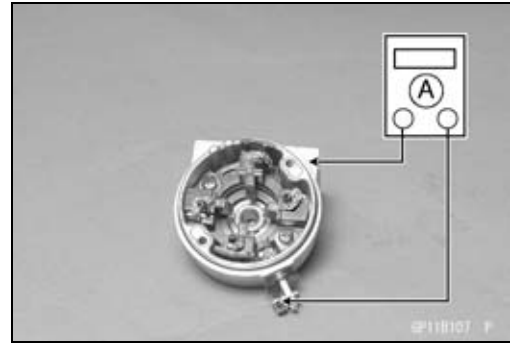

### Starter Relay Inspection

- Remove:
  - Left Side Cover (see Left Side Cover Removal in the Frame chapter)
  - Connector [A]
  - Battery Cable [B]
  - Starter Cable [C]
  - Starter Relay [D]

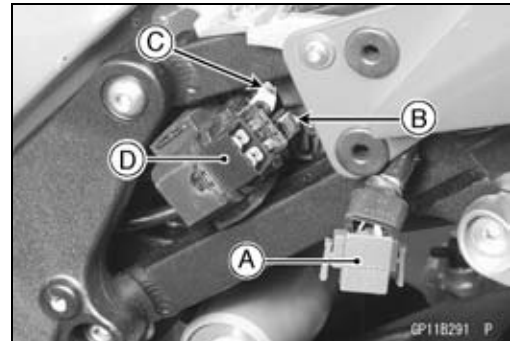

- Connect the hand tester [A] and 12 V battery [B] to the starter relay [C] as shown.

**Special Tool - Hand Tester: 57001-1394**

- ★ If the relay does not work as specified, the relay is defective. Replace the relay.

### Testing Relay

**Tester Range: × 1 Ω range**

**Criteria: When battery is connected → 0 Ω**

**When battery is disconnected → ∞ Ω**

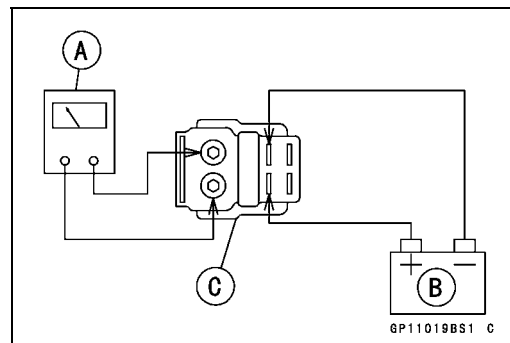

## Electric Starter System

## Electric Starter Circuit

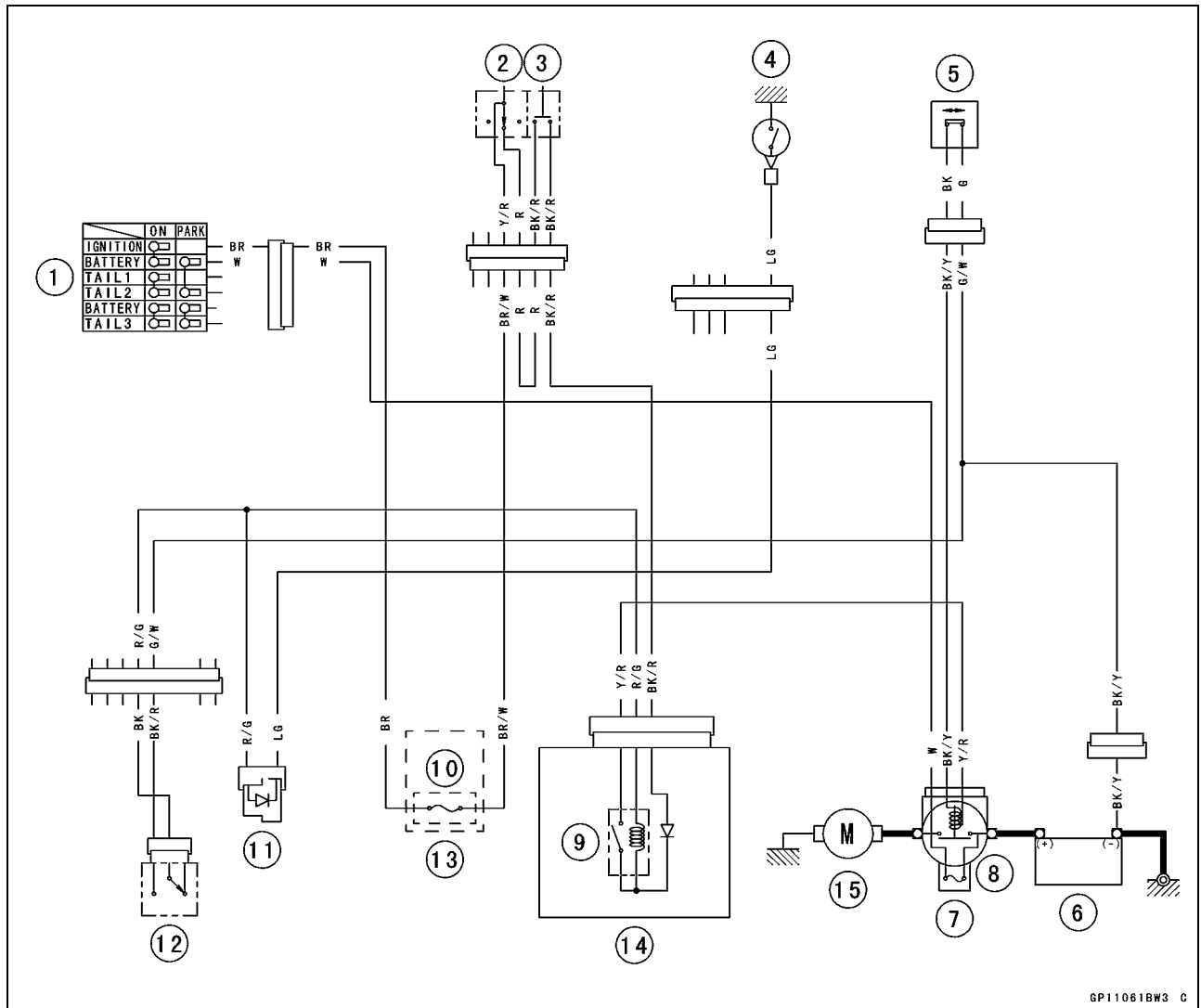

1. Ignition Switch
2. Engine Stop Switch
3. Starter Button
4. Neutral Switch
5. Side Stand Switch
6. Battery 12 V 8 Ah
7. Starter Relay
8. Main Fuse 30 A
9. Starter Circuit Relay
10. Ignition Fuse 10 A
11. Diode
12. Starter Lockout Switch
13. Fuse Box
14. Relay Box
15. Starter Motor

## 16-54 ELECTRICAL SYSTEM

### Lighting System

This motorcycle adopt the daylight system and have a headlight relay in the relay box. The headlight does not go on when the ignition switch and the engine stop switch are first turned on. The headlight comes on after the starter button is released and stays on until the ignition switch is turned off. The headlight will go out momentarily whenever the starter button is pressed and come back on when the button is released.

#### *Headlight Beam Horizontal Adjustment*

- Refer to the Headlight Aiming Inspection in the Periodic Maintenance chapter.

#### *Headlight Beam Vertical Adjustment*

- Refer to the Headlight Aiming Inspection in the Periodic Maintenance chapter.

#### *Headlight Bulb Replacement*

- Turn the dust cover [A] counterclockwise [B].

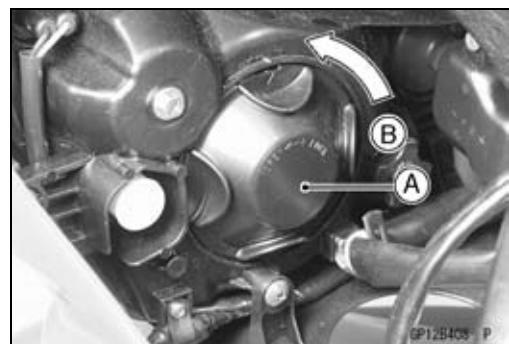

- Remove:
  - Headlight Connector [A]
  - Hook [B]
  - Headlight Bulb [C]

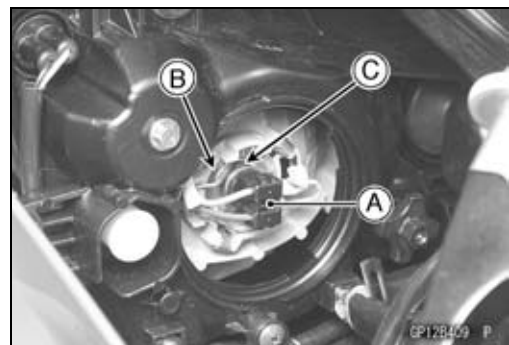

#### CAUTION

**When handling the quartz-halogen bulb, never touch the glass portion with bare hands. Always use a clean cloth. Oil contamination from hands or dirty rags can reduce bulb life or cause the bulb to explode.**

#### NOTE

○Clean off any contamination that inadvertently gets on the bulb with alcohol or soap and water solution.

- Replace the headlight bulb.
- Fit the projection [A] of the bulb in the hollow [B] of the headlight.

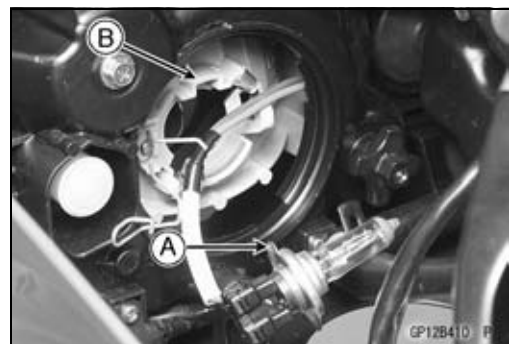

## Lighting System

- Turn the dust cover clockwise, align the mark [A] on the headlight and mark [B] the dust cover.
- After installation, adjust the headlight aim (see Headlight Aiming Inspection in the Periodic Maintenance chapter).

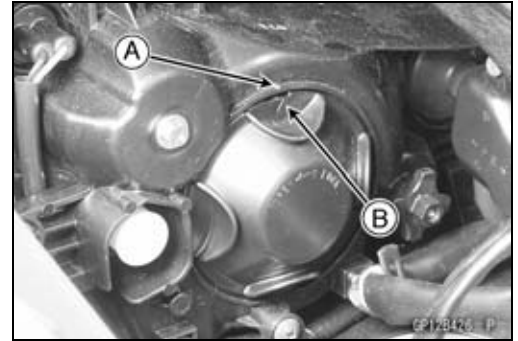

### City Light Bulb Replacement

- Remove:
  - Upper Inner Fairing (see Upper Inner Fairing Removal in the Frame chapter)
- Turn the socket [A] counterclockwise and pull out the socket together with the bulb.

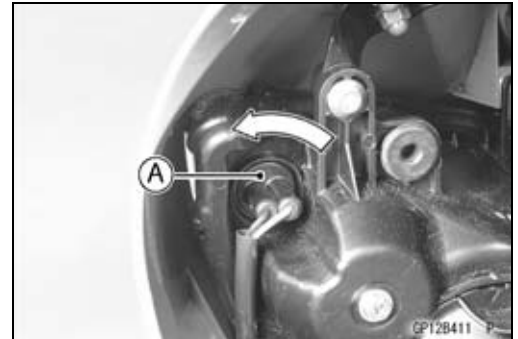

- Pull the bulb [A] out of the socket [B].

<b>CAUTION</b>
<b>Do not turn the bulb. Pull the bulb out to prevent damage to the bulb. Do not use bulb rated for greater wattage than the specified value.</b>

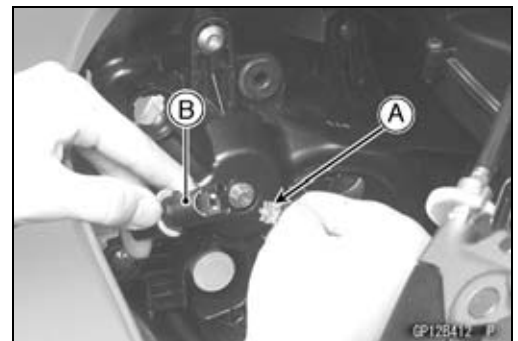

- Pushing the socket and turn it clockwise.
- Fit the projections [A] of the socket into the grooves [B] of the headlight.

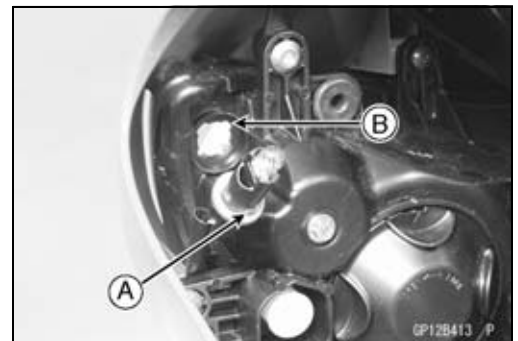

### Headlight Removal/Installation

- Remove:
  - Upper Fairing (see Upper Fairing Removal in the Frame chapter)
- Remove:
  - Bolts [A]
  - Screws [B]
- Refer to the Upper Fairing Assembly in the Frame chapter.



## 16-56 ELECTRICAL SYSTEM

### Lighting System

#### *Tail/Brake Light (LED) Removal*

- Remove:
  - Seat Cover (see Seat Cover Removal in the Frame chapter)
- Unscrew the mounting bolt [A].
- Remove the tail/brake light (LED) [B].

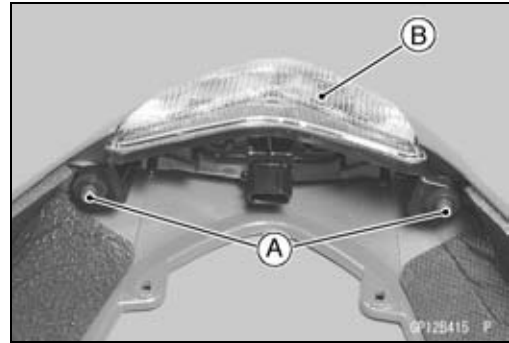

#### *Tail/Brake Light (LED) Installation*

- Refer to the Seat Cover Installation in the Frame chapter.

#### *License Plate Light Bulb Replacement*

- Remove:
  - Screws [A]
  - License Plate Light Cover [B]
  - Bulb
- Insert the new bulb [A] by aligning its upper and lower pins [B] with the upper and lower grooves [C] in the socket, and turn the bulb clockwise.
- Turn the bulb about 15° degrees.

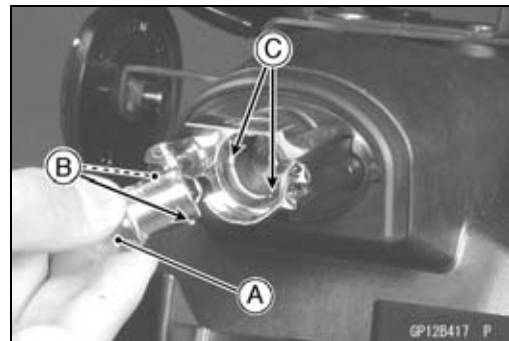
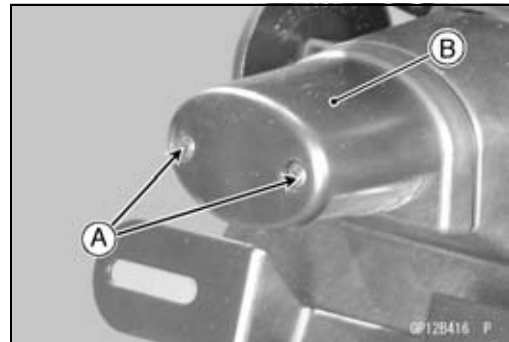

Lighting System

Headlight/Tail Light Circuit

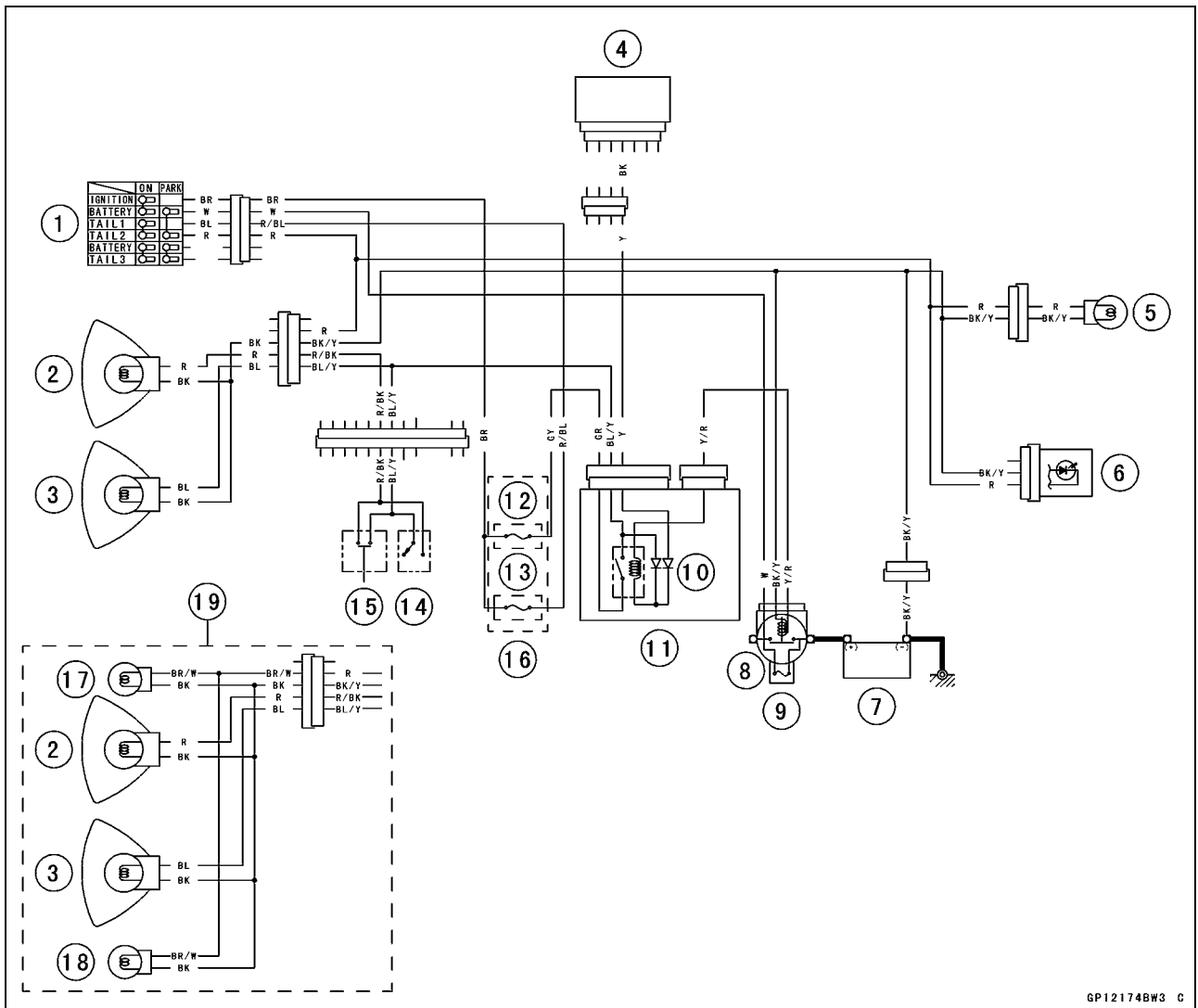

GP12174BW3 C

1. Ignition Switch
2. Headlight (High Beam)
3. Headlight (Low Beam)
4. Regulator/Rectifier
5. License Plate Light
6. Tail/Brake Light (LED)
7. Battery 12 V 8 Ah
8. Main Fuse 30 A
9. Starter Relay
10. Headlight Relay
11. Relay Box
12. Headlight Fuse 10 A
13. Tail Light Fuse 10 A
14. Dimmer Switch
15. Passing Button
16. Fuse Box
17. Right City Light
18. Left City Light

## 16-58 ELECTRICAL SYSTEM

### Lighting System

#### Turn Signal Light Bulb Replacement

##### For the European, Malaysian and Australian Models

- Remove:
  - Lower Fairings (see Lower Fairing Removal in the Frame chapter)
  - Center Fairings (see Center Fairing Removal in the Frame chapter)
- Turn the socket [A] counterclockwise and pull out the socket together with the bulb.
- Push and turn the bulb counterclockwise and remove it.
  
- Unscrew:
  - Screw [A]
- Remove:
  - Turn Signal Light [B]

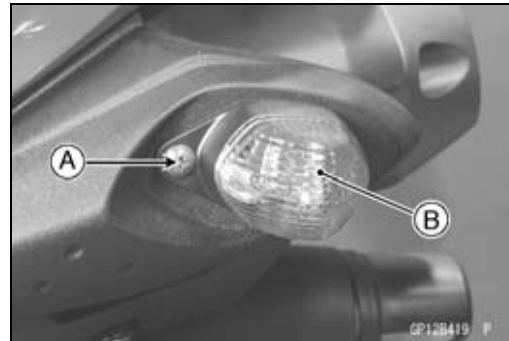
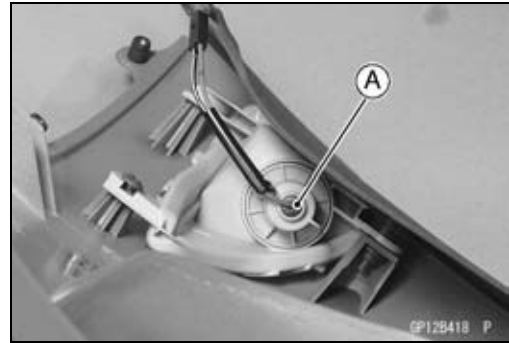

- Unscrew the screw [A] and removed the signal lens [B].
- Push and turn the bulb counterclockwise and remove it.

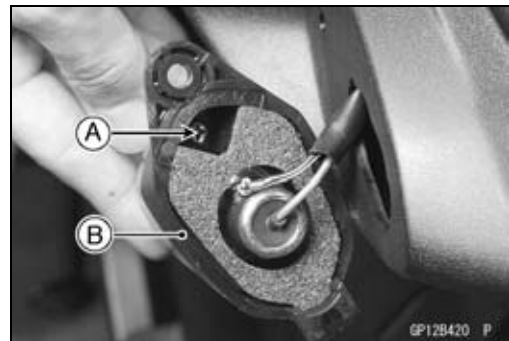

- Insert the new bulb [A] by aligning its upper and lower pins [B] with the upper and lower grooves [C] in the socket, and turn the bulb clockwise.
- Turn the bulb about 15° degrees.

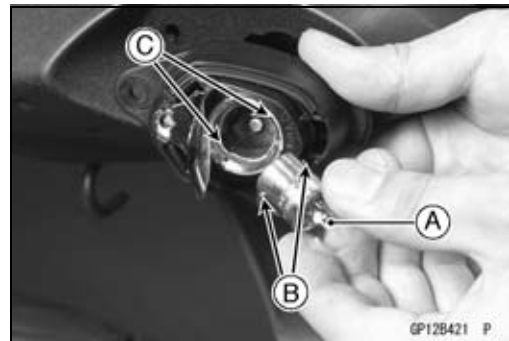

##### For the U.S.A. and Canadian Models

- Unscrew the screw [A] and remove the turn signal lens [B].

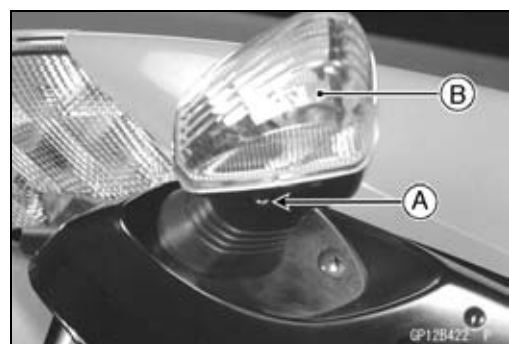

## Lighting System

- Push and turn the bulb [A] counterclockwise and remove it.



- Insert the new bulb [A] by aligning its upper and lower pins [B] with the upper and lower grooves [C] in the socket, and turn the bulb clockwise.

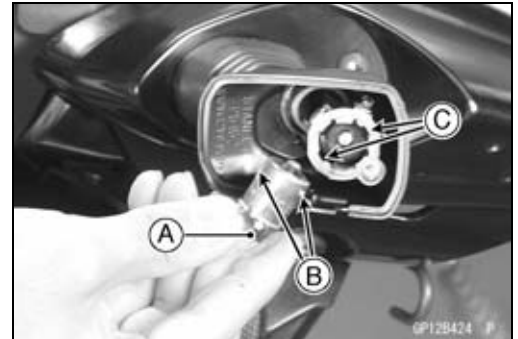

### Turn Signal Relay Inspection

- Remove:
  - Seat Cover (see Seat Cover Removal in the Frame chapter)
  - Turn Signal Relay [A]

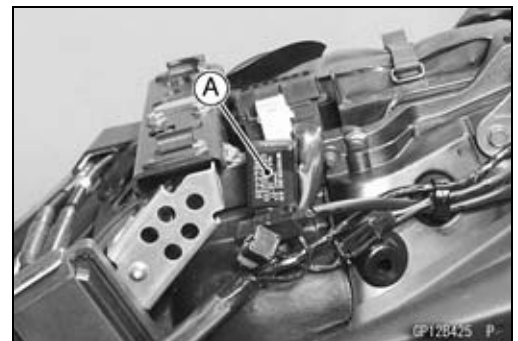

### United States, Canada and New Zealand Models

- Connect one 12 V battery and turn signal lights as indicated in the figure, and count how many times the lights flash for one minute.
  - Turn Signal Relay [A]
  - Turn Signal Lights [B]
  - 12 V Battery [C]
- ★ If the lights do not flash as specified, replace the turn signal relay.

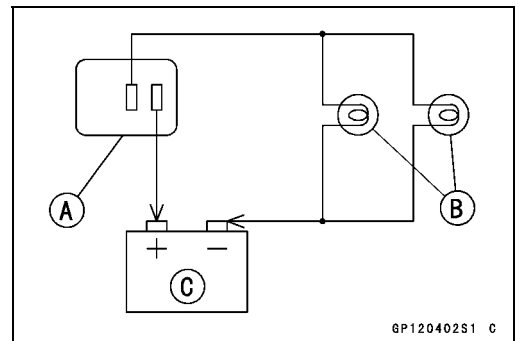

### Testing Turn Signal Relay

Load		Flashing Times (c/m*)
The Number of Turn Signal Lights	Wattage (W)	
1**	21	140 ~ 250
2	42	75 ~ 95

\*: Cycle(s) per minute

\*\* : Correspond to "one light burned out"

# 16-60 ELECTRICAL SYSTEM

## Lighting System

### Other than United States, Canada and New Zealand Models

- Connect one 12 V battery and turn signal lights as indicated in the figure, and count how many times the lights flash for one minute.

Turn Signal Relay [A]

Turn Signal Lights [B]

12 V Battery [C]

- ★ If the lights do not flash as specified, replace the turn signal relay.

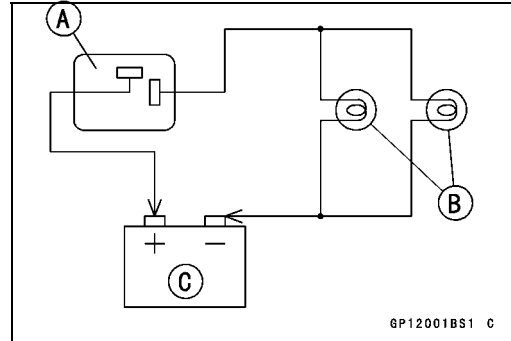

### Testing Turn Signal Relay

Load		Flashing Times (c/m*)
The Number of Turn Signal Lights	Wattage (W)	
1**	21	Light stays on
2	42	75 ~ 95

\*: Cycle(s) per minute

\*\* : Correspond to "one light burned out"

## Lighting System

## Turn Signal Light Circuit

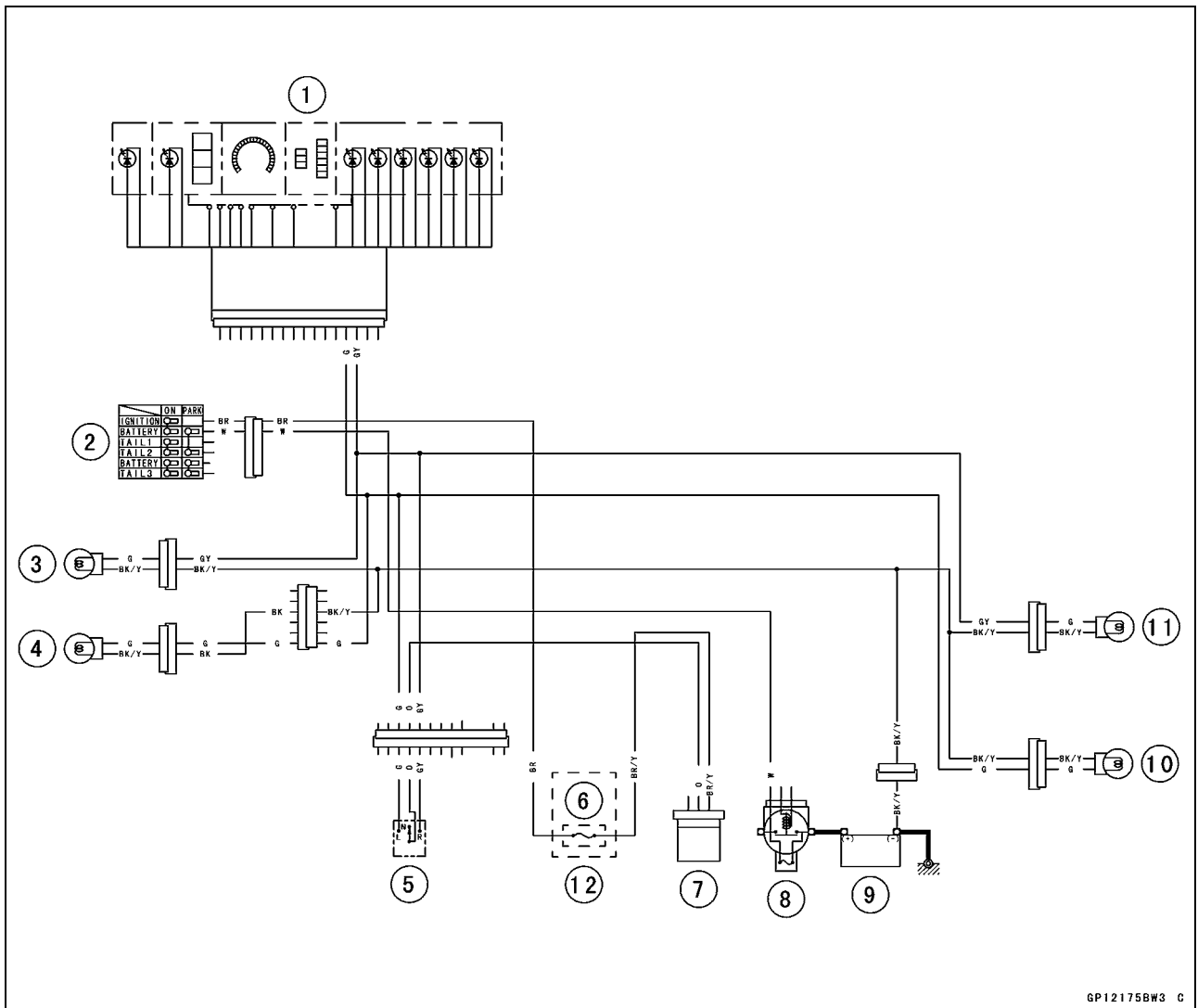

1. Meter Unit
2. Ignition Switch
3. Front Right Turn Signal Light
4. Front Left Turn Signal Light
5. Turn Signal Switch
6. Turn Signal Relay Fuse 10 A
7. Turn Signal Relay
8. Main Fuse 30 A
9. Battery 12 V 8 Ah
10. Rear Left Turn Signal Light
11. Rear Right Turn Signal Light
12. Fuse Box

## 16-62 ELECTRICAL SYSTEM

### Radiator Fan System

#### *Fan Motor Inspection*

- Remove the air cleaner housing (see Air Cleaner Housing Removal in the Fuel System (DFI) chapter).
- Disconnect the connector [A].
- Using an auxiliary leads, supply battery power to the fan motor.
- ★ If the fan does not rotate, the fan motor is defective and must be replaced.

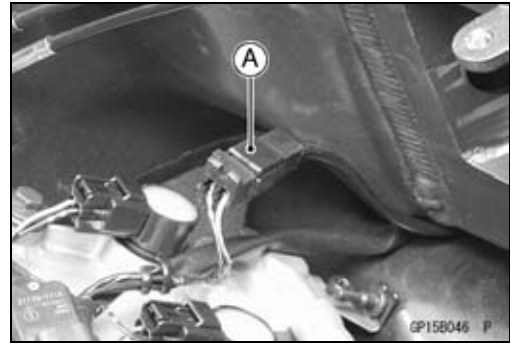

Radiator Fan System

Radiator Fan Circuit

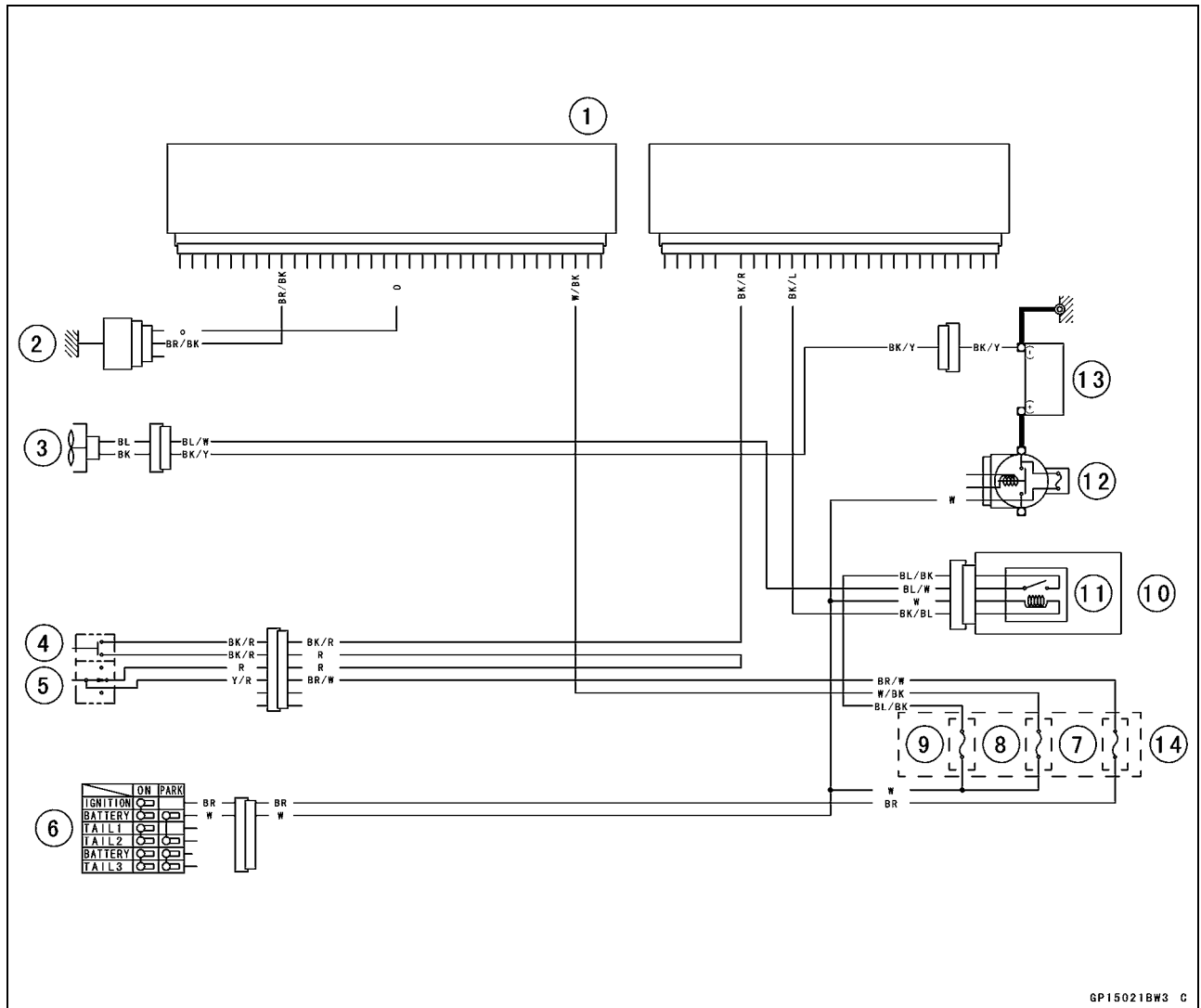

GP15021BW3 C

1. ECU
2. Water Temperature Sensor
3. Radiator Fan
4. Starter Button
5. Engine Stop Switch
6. Ignition Switch
7. Ignition Fuse 10 A
8. ECU Fuse 15 A
9. Fan Fuse 15 A
10. Relay Box
11. Radiator Fan Relay
12. Main Fuse 30 A
13. Battery 12 V 8 Ah
14. Fuse Box

## 16-64 ELECTRICAL SYSTEM

### Meter, Gauge, Indicator Unit

#### Meter Unit Removal

- Remove:
  - Upper Fairing (see Upper Fairing Removal in the Frame chapter)
  - Nuts [A]
  - Screws [B]

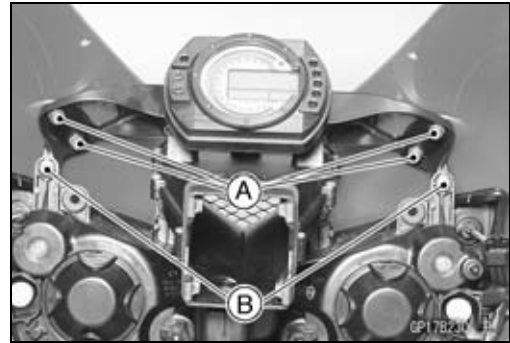

- Remove the bolts [A].

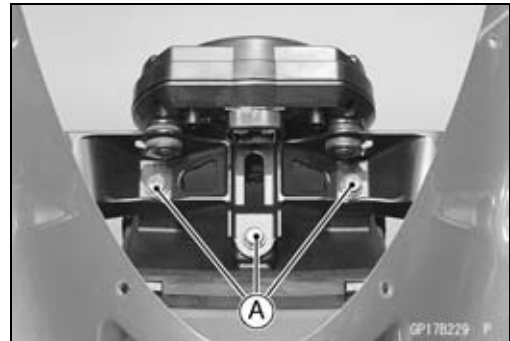

- Remove the screws [A].

#### CAUTION

Place the meter unit so that the face is up. If a meter unit is left upside down or sideways for any length of time, it will malfunction.



#### Meter Unit Disassembly

- Remove:
  - Meter Unit (see Meter Unit Removal in this chapter)
  - Screws [A]
  - Lower Meter Cover [B]



- Separate the meter assembly [A] and upper meter cover [B].

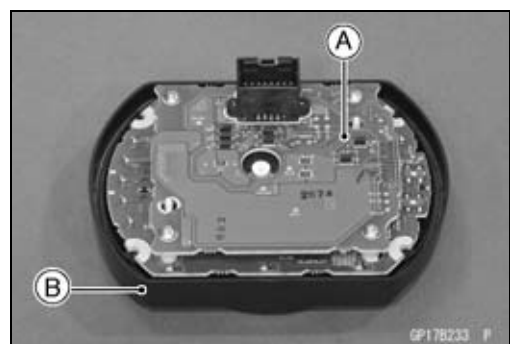

**Meter, Gauge, Indicator Unit**

*Electronic Combination Meter Assembly Inspection*

- Remove the meter assembly [A].
  - [1] Ignition
  - [2] Fuel Reserve Switch
  - [3] Stop Watch (+)
  - [4] Lap Time (+)
  - [5] Neutral Indicator Light (LED) Ground (-)
  - [6] FI Indicator Light (LED) Ground (-)
  - [7] Tachometer Pulse
  - [8] Water Temperature Sensor
  - [9] Ground (-)
  - [10] Battery (+)
  - [11] Oil Pressure Warning Indicator Light (LED) Ground (-)
  - [12] Speed Sensor Supply Voltage
  - [13] Right Turn Signal Light (LED) (+)
  - [14] Left Turn Signal Indicator Light (LED) (+)
  - [15] High Beam Indicator Light (LED)
  - [16] Speed Sensor Pulse

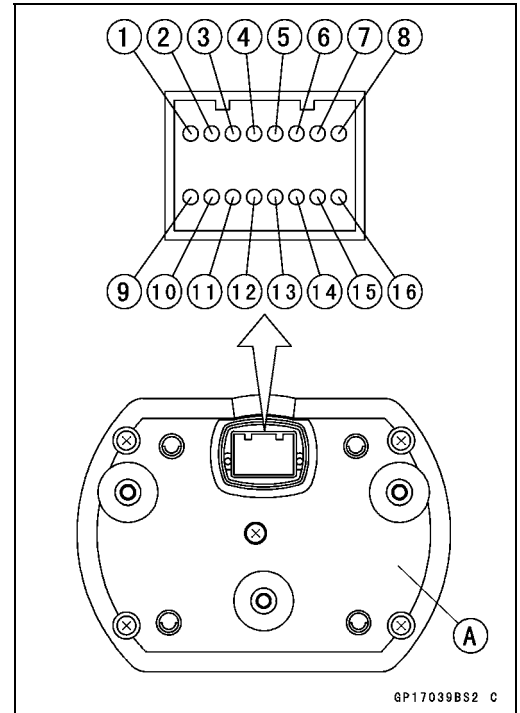

**CAUTION**

**Do not drop the meter unit. Place the meter unit so that it faces upward. If the meter assembly is left upside down or sideways for a long time or dropped, it will malfunction.**

**CAUTION**

**Do not short each terminals.**

**Liquid Crystal Display (LCD) Segments Check**

- Connect the harness adapter to the meter assembly connector.

**Special Tool - Harness Adapter: 57001-1542**

- Using the auxiliary wires, connect the 12 V battery to the each connector of harness adapter as follows.
  - Connect the battery positive terminal to the terminal [10].
  - Connect the battery negative terminal to the terminal [9].

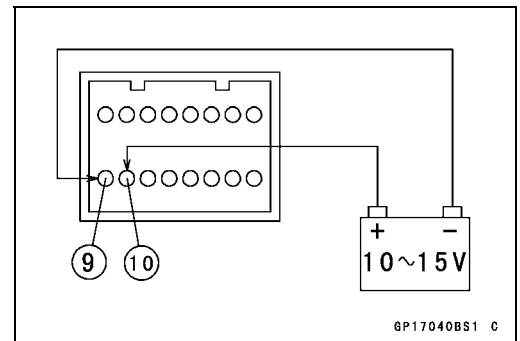

- Connect the terminal [1] to the terminal [10].

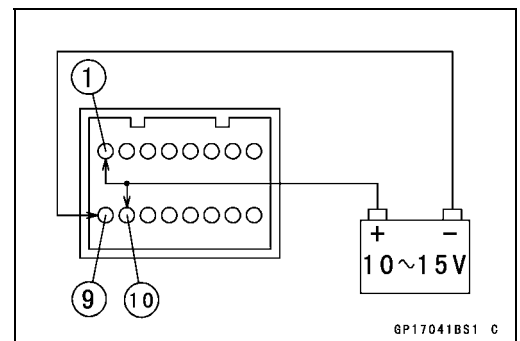

# 16-66 ELECTRICAL SYSTEM

## Meter, Gauge, Indicator Unit

- The tachometer LCD segments momentarily to its last readings two times and segment movement is reversal.
- When the terminals are connected, all the LCD segments [A] and LED light [B] appear for three seconds.
- ★If the LCD segments and LED warning light will not appear, replace the meter assembly.
- Disconnect the terminal [1].
- All the LCD segments and LED warning light disappear.
- ★If the segments do not disappear, replace the meter assembly.

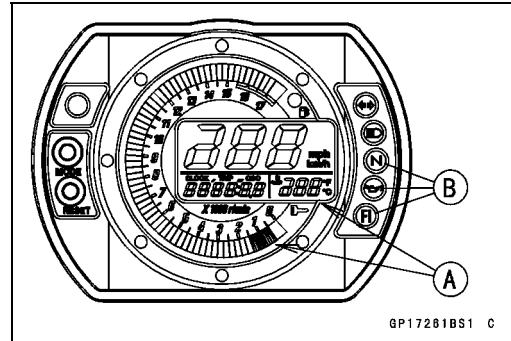

### MODE AND RESET BUTTON Operation Check

- Connect the 12 V battery and terminals in the same manner as specified in the “Liquid Crystal Display (LCD) Segments Check”.
- Check that the display [B] change to the ODO, TRIP, CLOCK and STOP WATCH displays each time the mode selector button [A] is pressed.
- If the fuel level warning indicator light (LED) blinked, display change to ODO, TRIP, CLOCK, STOP WATCH and FUEL.
- ★If the display function does not work, replace the meter assembly.

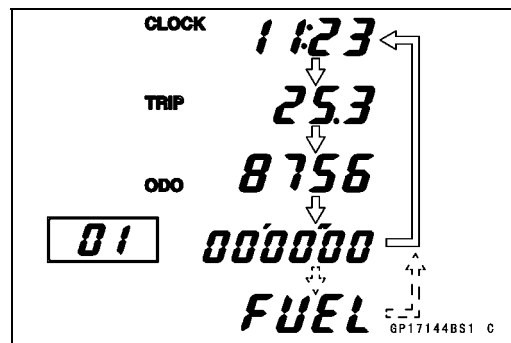
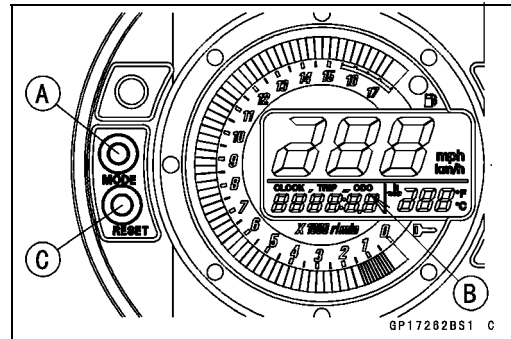

- Indicate the clock mode.
- Check that when the RESET button in CLOCK mode is pushed for more than two seconds, the meter display turns to the clock set mode.
- Both the hour and minute display start flashing.

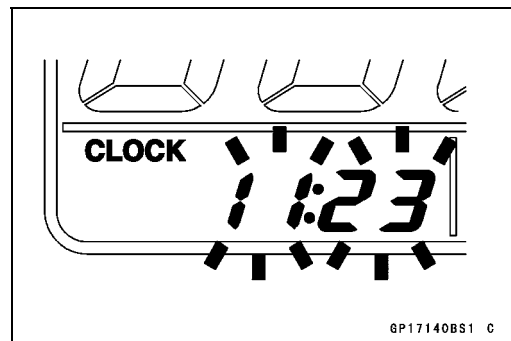

- In the HOUR/MINUTE setting mode, press the reset button [C] again to effect the HOUR setting mode.
- The hour display flashes on the display.
- Press the mode selector button [A] to set the hour.

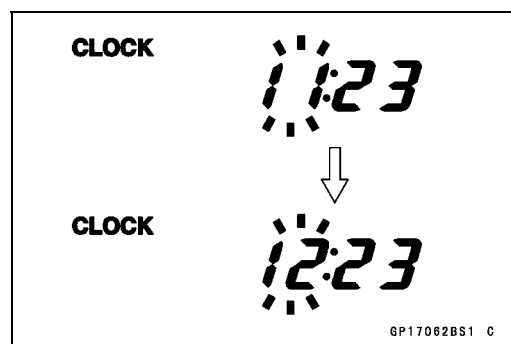

## Meter, Gauge, Indicator Unit

- In the HOUR setting mode, press the reset button [C] to effect the MINUTE setting mode.
- The minute display flashes on the display.
- Press the mode selector button [A] to set the minute.

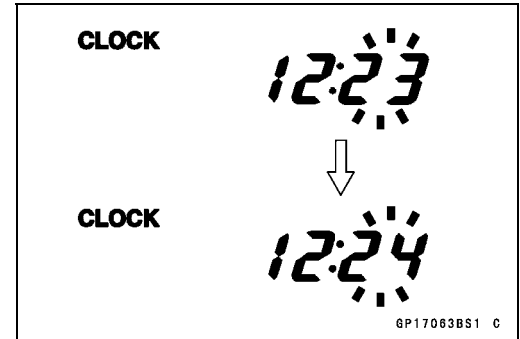

- In the MINUTE setting mode, press the reset button [C] to return to the HOUR/MINUTE setting mode.
- Press the mode selector button [A] to complete the time setting process.
- The clock starts counting the seconds a soon as the mode selector button is pressed.

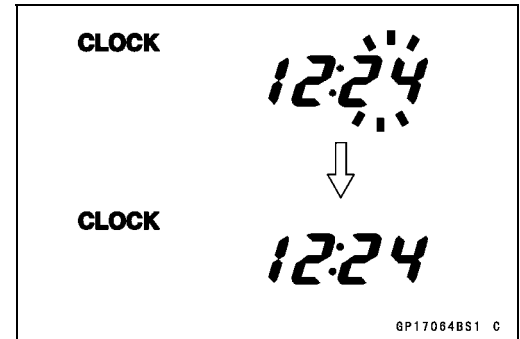

- Indicate the ODO mode.
- ★ If the display function does not work and adjust, replace the meter assembly.
- ★ Check that the display [A] [B] change to the mile and °F, Mile and °C, km and °F, km and °C display each time by pushing the RESET bottom while MODE bottom pushed in.

### NOTE

○ Mile/Km Display can alternate between English and metric modes (mile and km) in the digital meter. Make sure that km or mile according to local regulations is correctly displayed before riding.

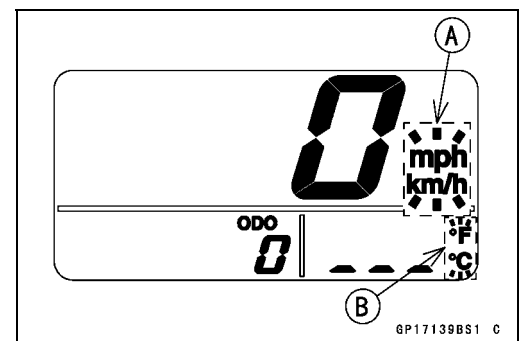

### Speedometer Check

- Connect the 12 V battery and terminals in the same manner as specified in the "Liquid Crystal Display (LCD) Segments Check".
- The speed equivalent to the input frequency is indicated in the oscillator [A], if the square wave (illustrated as shown) would be input into the terminal [16].
- Indicates approximately 60 mph in case the input frequency would be approximately 1 168 Hz.
- Indicates approximately 60 km/h in case the input frequency would be approximately 730 Hz.

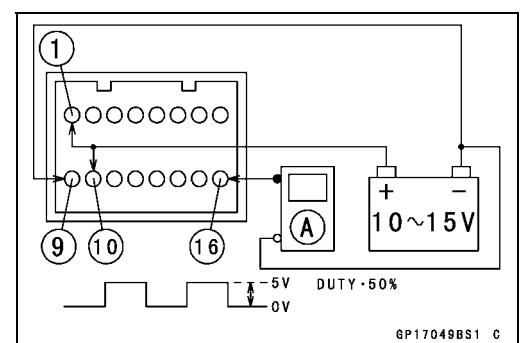

- If the oscillator is not available, the speedometer can be checked as follows.
- Install the meter unit.
- Raise the rear wheel off the ground, using the jack.
- Turn on the ignition switch.
- Rotate the rear wheel by hand.
- Check that the speedometer shows the speed.
- ★ If the speedometer does not work, check the speed sensor electric source voltage and speed sensor.
- ★ The electric source voltage and speed sensor are normal, replace the meter assembly.

# 16-68 ELECTRICAL SYSTEM

## Meter, Gauge, Indicator Unit

### Speed Sensor Electric Source Check

- Connect the 12 V battery and terminals in the same manner as specified in the “Liquid Crystal Display (LCD) Segments Check”.
- Set the hand tester to the DC 25 V range and connect it to the terminals [12] and [9].
- ★ If the voltage is less than 8 V, replace the meter assembly.

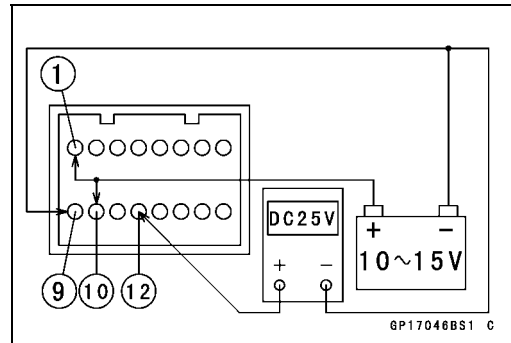

### Odometer Check

- Check the odometer with the speedometer check in the same way.
- ★ If value indicated in the odometer is not added, replace the meter assembly.

#### NOTE

- The data is maintained even if the battery is disconnected.
- When the figures come to 999999, they are stopped and locked.

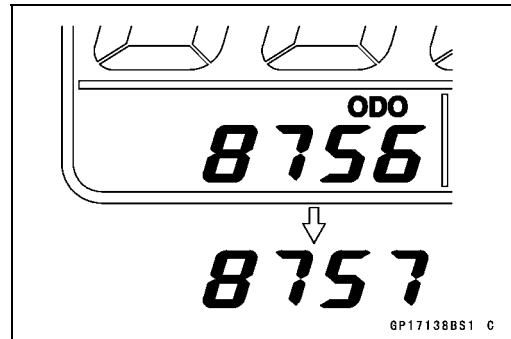

### Trip Meter Check

- Check the trip meter with the speedometer in the same way.
- ★ If value indicated in the trip meter is not added, replace the meter assembly.
- Check that when the RESET button is pushed for more than two seconds, the figure display turns to 0.0.
- ★ If the figure display does not indicate 0.0, replace the meter assembly.

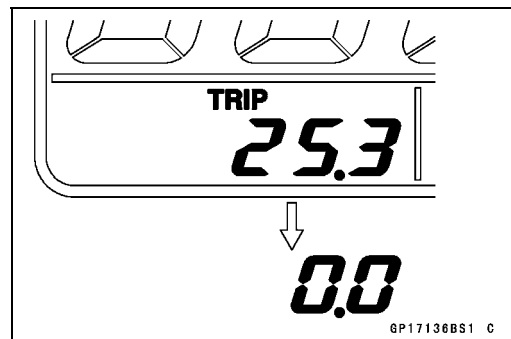

### Water Temperature Meter Check

- Connect the 12 V battery and terminals in the same manner as specified in the “Liquid Crystal Display (LCD) Segments Check”.
- Connect the variable rheostat [A] to the terminal [8] as shown.
- Check that the number of segments matches the resistance value of the variable rheostat.

Resistance Value (Ω)	Temperature Meter	Warning Indicate
	—	[A]—
209.8	50°C (122°F)	[B]—
69.1	80°C (176°F)	[B]—
21.2	120°C (248°F)	[C] Flash
17	HI	[D] Flash

- If any display function does not work, replace the meter assembly.

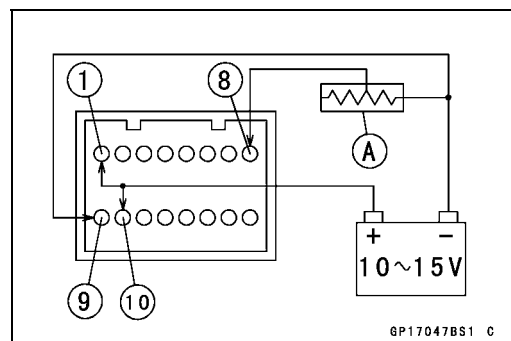

## Meter, Gauge, Indicator Unit

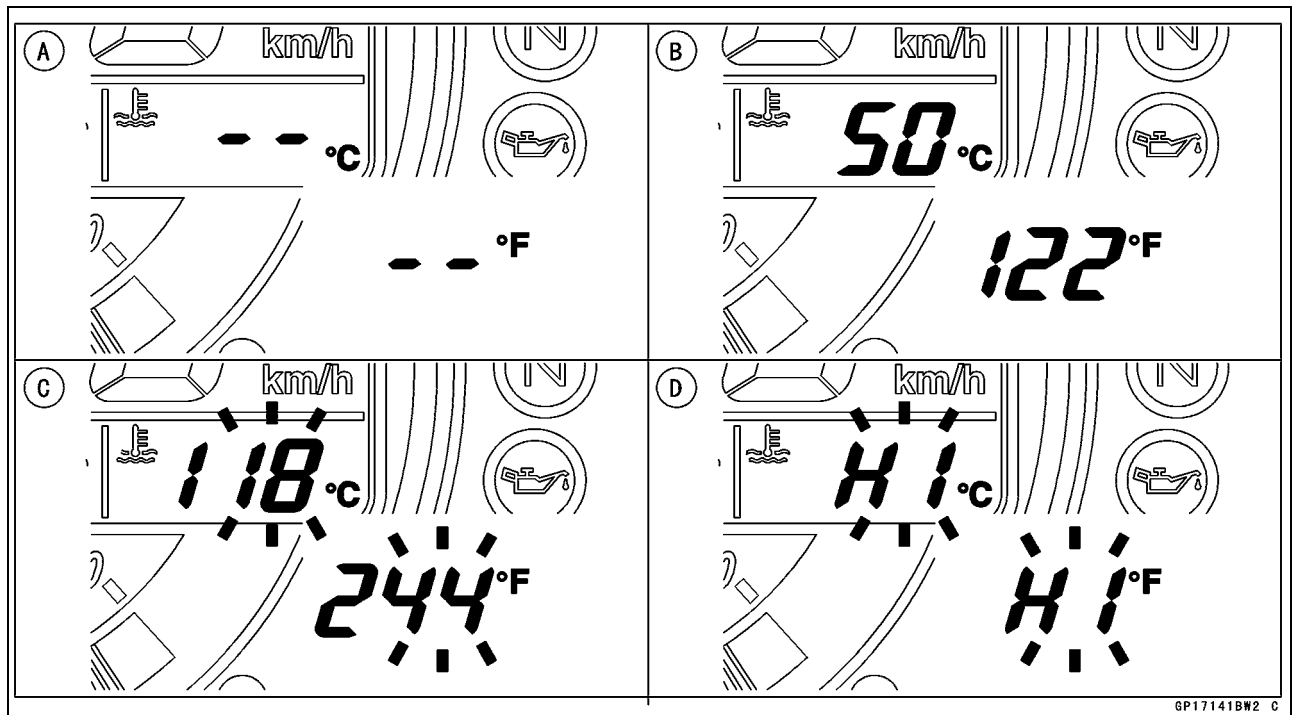
**Tachometer Check**

- Connect the 12 V battery and terminals in the same manner as specified in the “Liquid Crystal Display (LCD) Segments Check”.
  - The revolutions per minute (rpm) equivalent to the input frequency is indicated in the oscillator [A] if the square wave (illustrated as shown) would be input into the terminal [7].
- Indicates approximately 6 000 rpm in case the input frequency would be approximately 200 Hz.
- If the oscillator is not available, the tachometer can be checked as follows.
- Connect the 12 V battery and terminals in the same manner as specified in the “Liquid Crystal Display (LCD) Segments Check”.
- Using an auxiliary wire, quickly open and connect the terminal [1] to the terminal [7] repeatedly.
- Then the tachometer segment [A] should flick [B].
- ★ If the hand does not flick, replace the meter assembly.

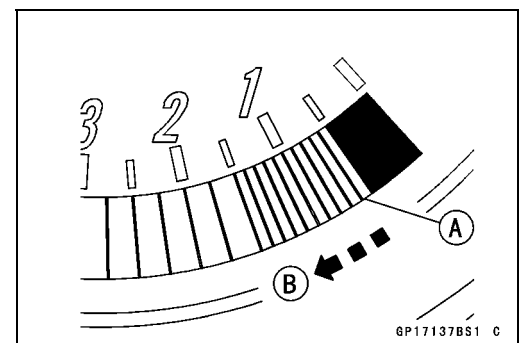
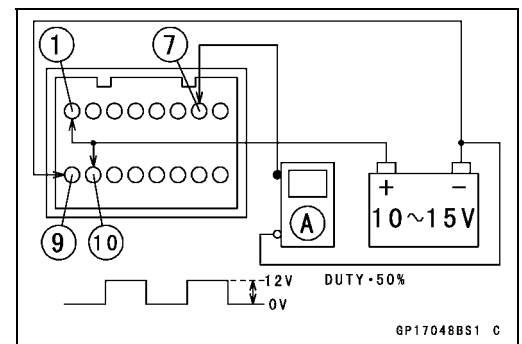

# 16-70 ELECTRICAL SYSTEM

## Meter, Gauge, Indicator Unit

### Stop Watch Check

- Connect the 12 V battery and terminal in the same manner as specified in the “Liquid Crystal Display (LCD) Segments Check”.
- Press the mode selector button each time to set the stop watch mode.
- Connect the auxiliary wire to the terminal [3] as shown, then stop watch start to count.
- While count the stop watch, connect the auxiliary wire to the terminal [4] as shown, then indicate the counted time during ten seconds.
- Connect the variable rheostat [A] to the terminal [8] as shown.
- When Set the resistance to less than  $21.1 \Omega$ , lap display segment indicate the water temperature.
- ★ If the display function does not work, replace the meter assembly.

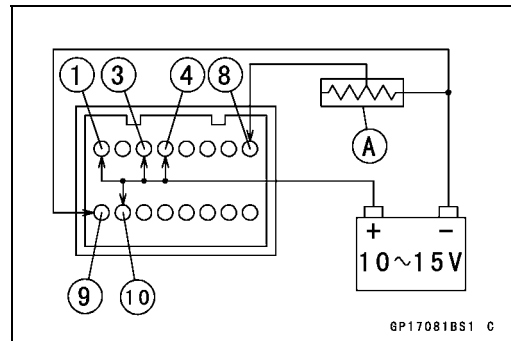
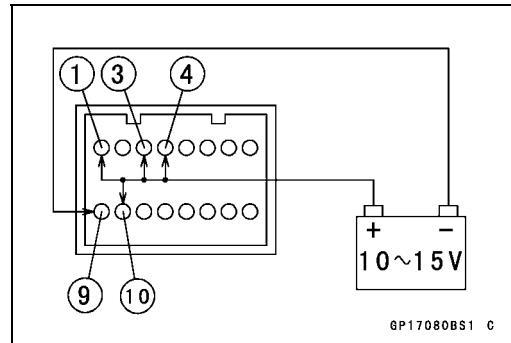

### Lights (LED) Inspection

- Connect the 12 V battery and terminals in the same manner as specified in the “Liquid Crystal Display (LCD) Segments check”.
- Neutral Indicator Light (LED) [A]
- FI Indicator Light (LED) [B]
- Oil Pressure Warning Indicator Light (LED) [C]
- Turn Signal Indicator Light (LED) [D]
- High Beam Indicator Light (LED) [E]
- Fuel Level Warning Indicator Light (LED) [F]
- Shift Up Indicator Light (LED) [G]

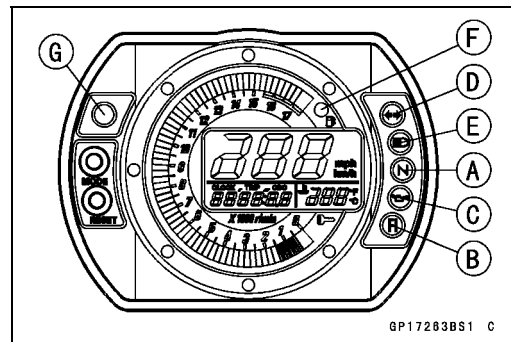

- Using the auxiliary leads and harness adapter, connect a 12 V battery to the meter unit connector as follows.

**Special Tool - Harness Adapter: 57001-1542**

### Neutral Indicator Light (LED)

Battery Negative (-) Terminal To Terminal [5]

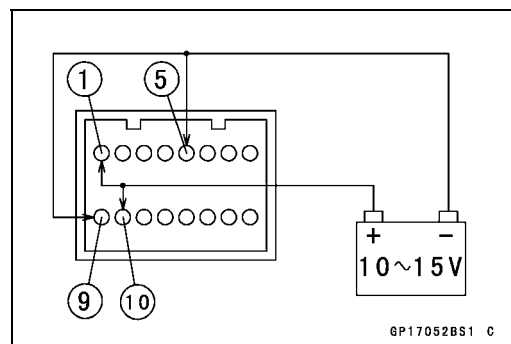

Meter, Gauge, Indicator Unit

**FI Indicator Light (LED)**

Battery Negative (-) Terminal To Terminal [6]

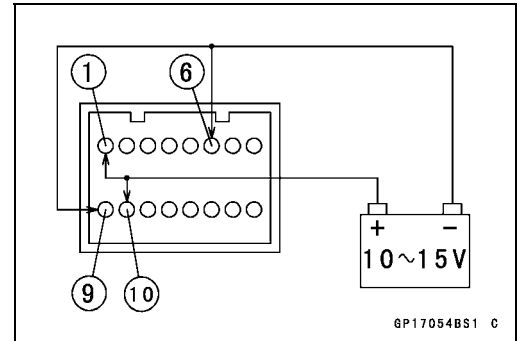

**Oil Pressure Warning Indicator Light (LED)**

Battery Negative (-) Terminal To Terminal [11]

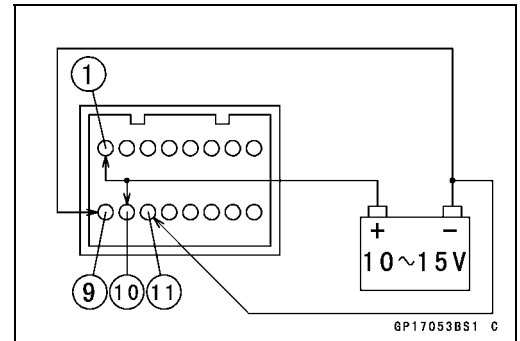

**Right and Left Turn Signal Indicator Light (LED)**

Battery Positive (+) Terminal to Terminal [13]

Battery Positive (+) Terminal to Terminal [14]

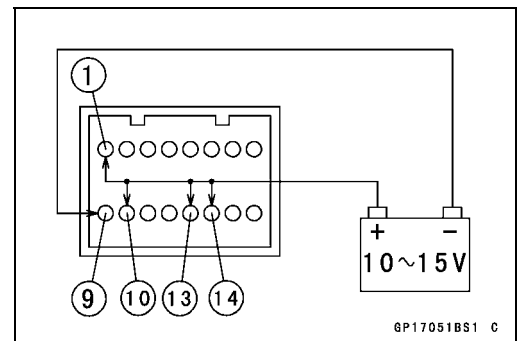

**High Beam Indicator Light (LED)**

Battery Positive (+) Terminal to Terminal [15]

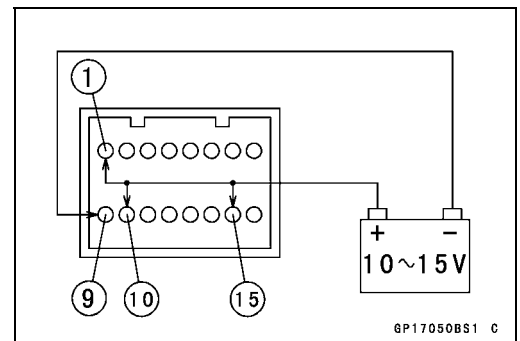

**Fuel Level Warning Indicator Light (LED)**

- Connect a variable rheostat [A] to terminal [2] and [9] as shown.
- Adjust the resistance value to the approximately 22 Ω.
- The FUEL segments flashes on the display.

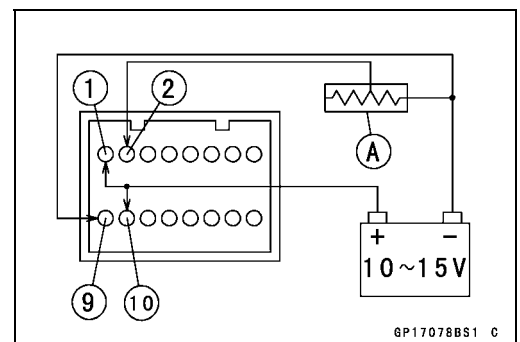

★If each lights (LED) does not go on, replace the meter assembly.

## 16-72 ELECTRICAL SYSTEM

### Meter, Gauge, Indicator Unit

#### Shift Up Indicator Light (LED)

- Connect the 12 V battery and terminal in the same manner as specified in the “Liquid Crystal Display (LCD) Segments Check”.
- The revolutions per minute (rpm) equivalent to the input frequency is indicated in the oscillator [A] if the square wave (illustrated as shown) would be input into the terminal [7].
- When set the oscillator more than 440 Hz, shift up indicator light (LED) go on.

★If each LED lights does not go on, replace the meter assembly.

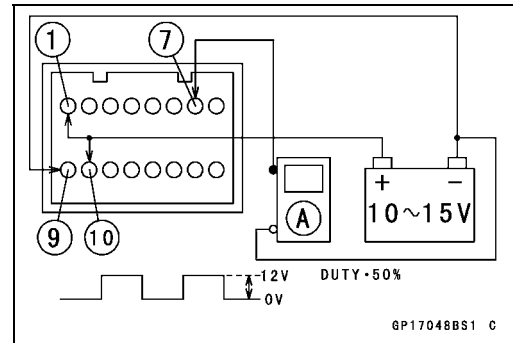

Meter, Gauge, Indicator Unit

Meter Circuit

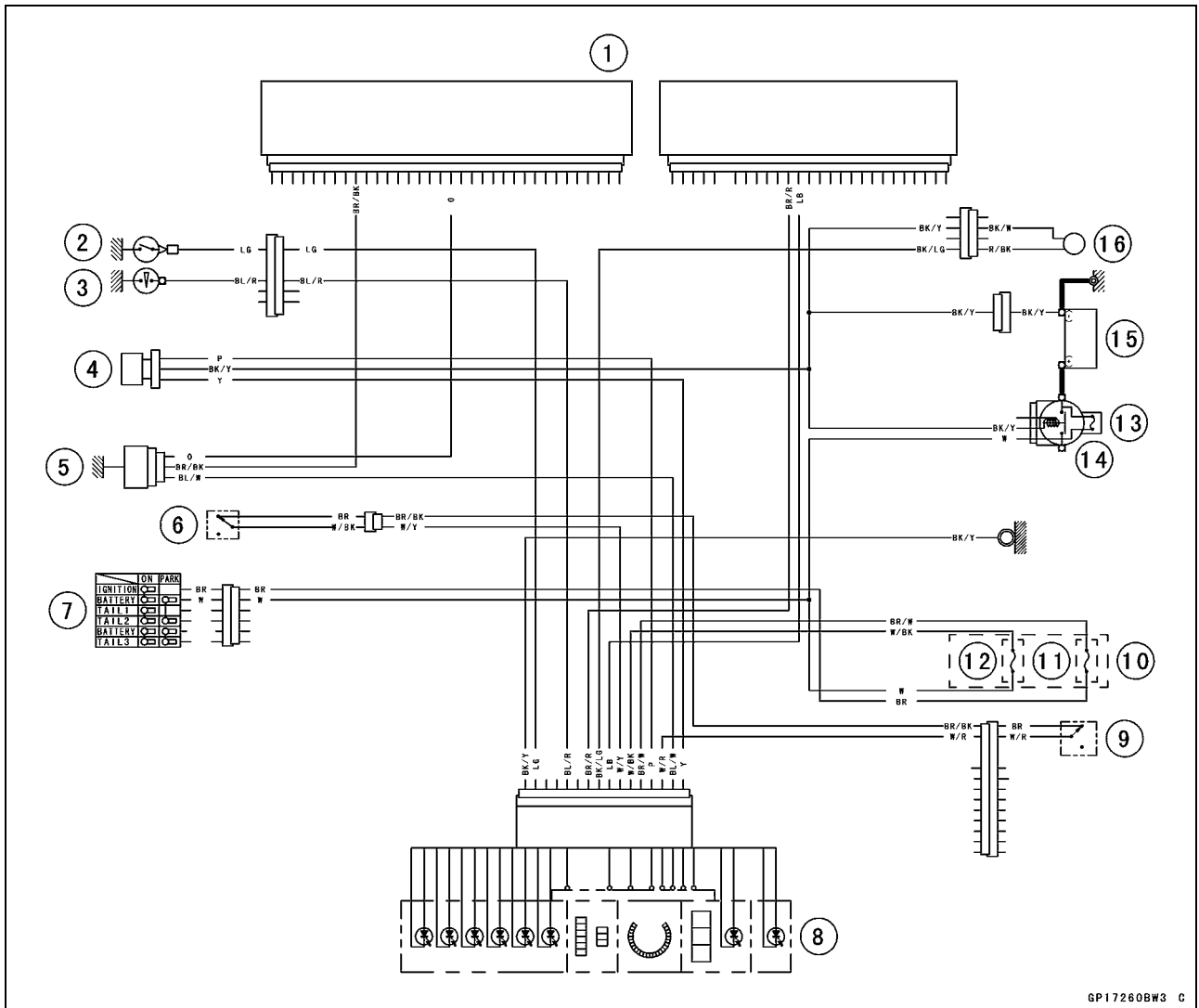

1. ECU
2. Neutral Switch
3. Oil Pressure Switch
4. Speed Sensor
5. Water Temperature Sensor
6. Stop Watch Switch
7. Ignition Switch
8. Meter Unit
9. Lap Switch
10. Fuse Box
11. Ignition Fuse 10 A
12. ECU Fuse 15 A
13. Starter Relay
14. Main Fuse 30 A
15. Battery 12 V 8 Ah
16. Fuel Reserve Switch

## 16-74 ELECTRICAL SYSTEM

### Immobilizer System (Equipped Models)

This motorcycle is equipped with an immobilizer system to protect the motorcycle from theft. This system provides a theft proof device by means of matching a code between the inbuilt key transponder and ECU (Electronic Control Unit). If the code does not match, ignition system, injectors, subthrottle valve actuator and exhaust butterfly valve actuator will not operate and the engine will not start.

#### Abstract

- Do not keep more than one immobilizer key of any system on a key ring. Jamming of the key code signal may occur and the operation of the system may be affected.
- The FI indicator light illuminates for two seconds and then extinguishes when the ignition is first switched on. This shows the system is operating correctly.
- If the FI indicator light illuminates when the ignition switch is turned to the ON position and stays illuminated this shows the DFI system has a fault. Refer to the service code to identify the faulty component.
- If the FI indicator light flashes when the ignition switch is turned to the ON position this shows the immobilizer system has a fault. Refer to service code to identify the faulty component.
- The FI indicator light will flash for a period of 24 hours once the ignition switch has been switched OFF and the key removed. This flashing can be set to on or off as desired by holding the Mode and Reset buttons down for two seconds within twenty seconds of switching the ignition off.
- If all coded keys (master key and user keys) are lost the ECU and ignition switch will have to be replaced.
- The immobilizer system can not function until the master key code is registered in the ECU.
- A total of six keys can be registered in the ECU at any one time (one master key and five user keys).
- If the master key is lost it is not possible to register new user keys.

#### Operational Cautions

1. Do not put two keys of any immobilizer system on the same key ring.
2. Do not submerge any key in water.
3. Do not expose any key to excessively high temperature.
4. Do not place any key close to magnet.
5. Do not place a heavy item on any key.
6. Do not grind any key or alter its shape.
7. Do not disassemble the plastic part of any key.
8. Do not drop the key and/or apply any shocks to the key.
9. When a user key is lost, the user should go to his dealer to invalidate the lost key registration in the electronic control unit (ECU).
10. When the master key is lost, the user should go to his dealer and have a new ECU installed and register a new master key and user keys.

#### NOTE

○ No.9 and 10 are strongly recommended to the customer to ensure security of the motorcycle.

#### Key Registration

**Case 1: When the user key has been lost or additional spare user key is required.**

- Prepare a new spare user key.
- Cut the key in accordance with the shape of the current user key.
- Remove:
  - Front Seat (see Front Seat Removal in the Frame chapter)
- Disconnect the immobilizer/Kawasaki self-diagnosis system connector [A].

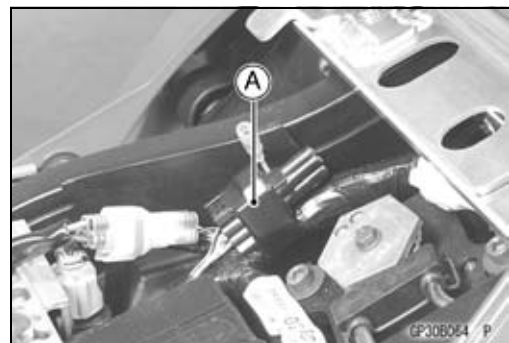

## Immobilizer System (Equipped Models)

- Connect the key registration unit [A].  
Special Tool - Key Registration Unit: 57001-1582



- Insert the master key to the ignition switch and turn it ON.  
**Verified**
- The FI indicator light [A] blinks to display the registration mode (go to the next step).

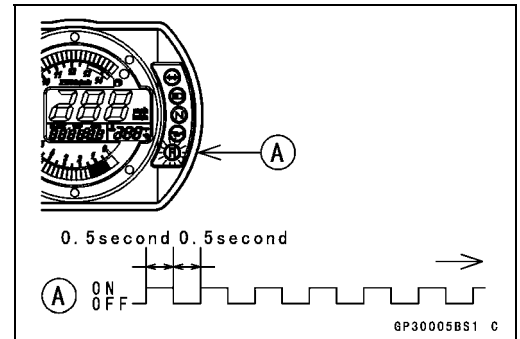

### Not Verified

- The FI indicator light [A] blinks to display the collation error (refer to the following failure illustrations).  
Immobilizer Amplifier Failure

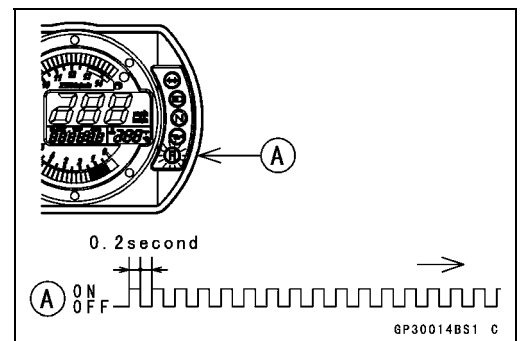

### Master Key Collation Error

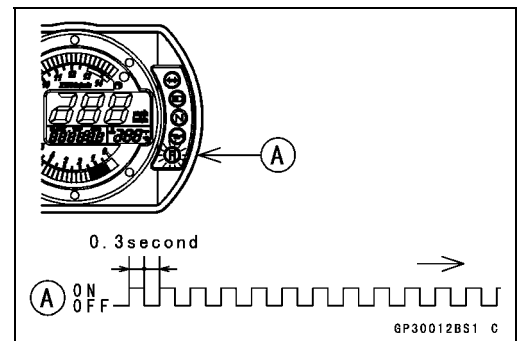

- Turn the master key OFF and remove the master key.
- The FI indicator light [A] blinks continuously to display that the ECU is in the registration mode for 15 seconds.

### NOTE

- Insert next key and turn ON within 15 seconds after previous key is turned off and removed otherwise registration mode will be ended and the FI indicator light stops flashing.
- To return to the registration mode start the master key verification procedure. This applies to all user key registration.

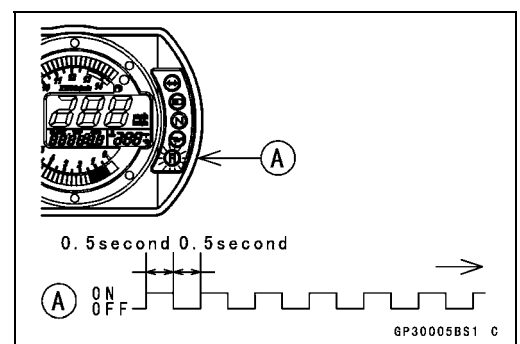

# 16-76 ELECTRICAL SYSTEM

## Immobilizer System (Equipped Models)

- Insert the user key 1 to the ignition switch and turn it ON.

### NOTE

○Keep the other user key away from the immobilizer antenna.

- If there is any problem in the registration, the FI indicator light [A] blinks to display the collation error.  
Immobilizer Amplifier Failure

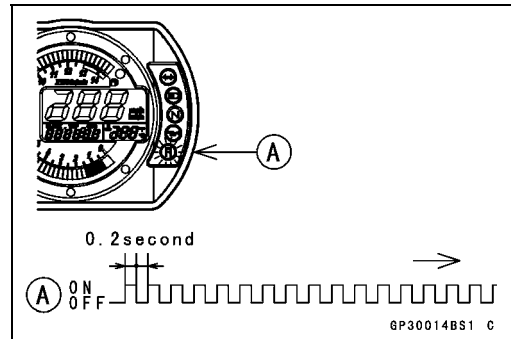

When Registered User Key is Inserted.

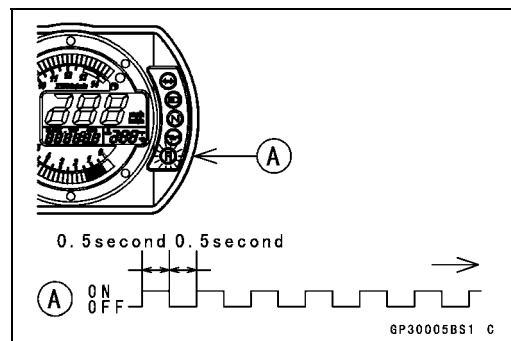

User Key Collation Error

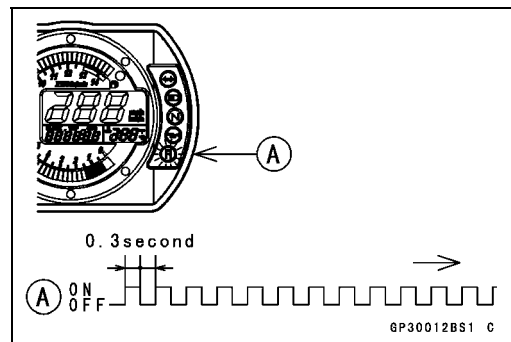

- The user key 1 is successfully registered in the ECU.
- The FI indicator light [A] blinks 2 times and stops for 1 second and then repeats this cycle.

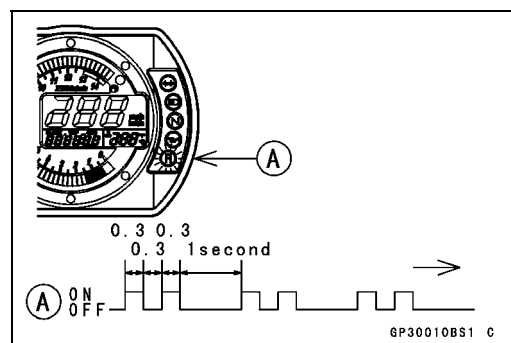

**Immobilizer System (Equipped Models)**

- Turn the user key 1 OFF and remove off the user key 1.
- The FI indicator light [A] blinks to display the registration mode.

**NOTE**

- Turn off the ignition switch and wait for the period of 15 seconds or more. The registration mode automatically finishes and the FI indicator light will switch off.
- This procedure registered the master key and one user key.
- Continue with the procedure to register the second and later keys before the 15 seconds period has elapsed.

- Insert the user key 2 to the ignition switch and turn it ON.

- If there is any problem in the registration, the FI indicator light [A] blinks to display the collation error.  
Immobilizer Amplifier Failure

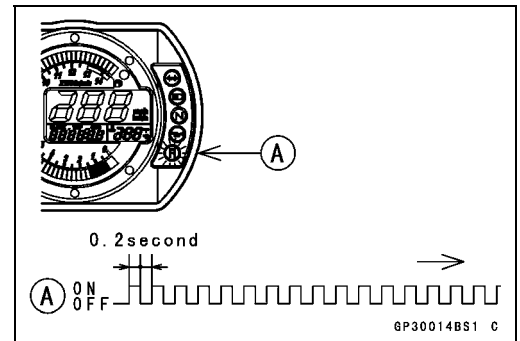
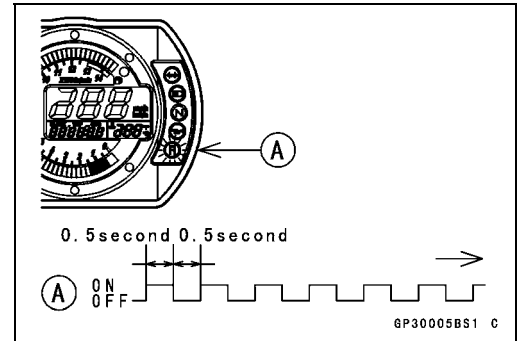

When Registered User Key is Inserted.

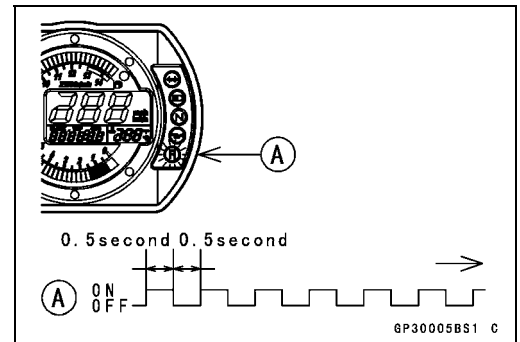

User Key Collation Error

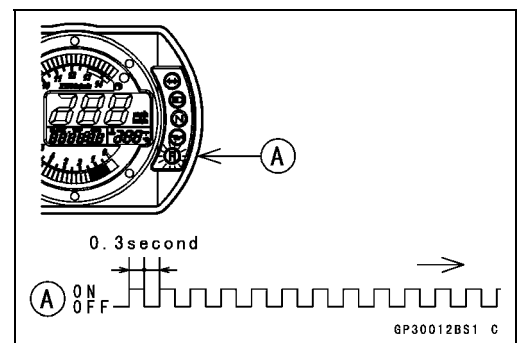

# 16-78 ELECTRICAL SYSTEM

## Immobilizer System (Equipped Models)

- The user key 2 is registered in the ECU.
- The FI indicator light [A] blinks 3 times and stops for 1 second and then repeats this cycle.
- This procedure has registered the master key and 2 user keys.
- Continue with the procedure to register an additional 3 user keys.

**NOTE**

○ The ECU can store up to the six key codes (master key × 1 and user key × 5).

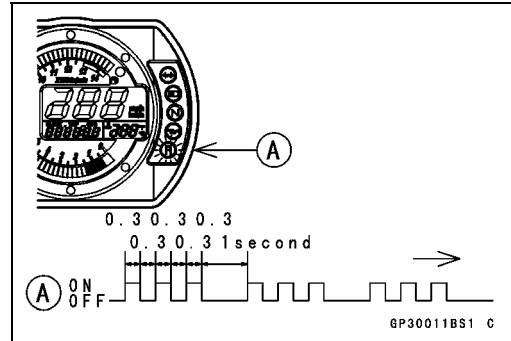

### User Key Indicator Flashes

	FI Indicator Light Blinks	FI Indicator Light Stop	Remarks
<b>User Key 3</b>	4 times	1 seconds	Repeat
<b>User Key 4</b>	5 times	1 seconds	Repeat
<b>User Key 5</b>	6 times	1 seconds	Repeat

- Turn OFF the ignition switch and wait for period of more than 15 seconds.
- The registration mode automatically ends.
- FI indicator light goes off [A].

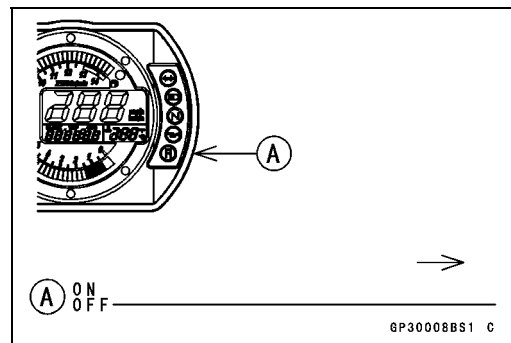

- Remove the key registration unit and connect the immobilizer Kawasaki self-diagnostic system connector.

**NOTE**

○ Turn the ignition switch ON with the registered user key.  
 ○ Check that the engine can be started using all registered user keys.

Immobilizer System (Equipped Models)

Spare User Key Registration Flow Chart

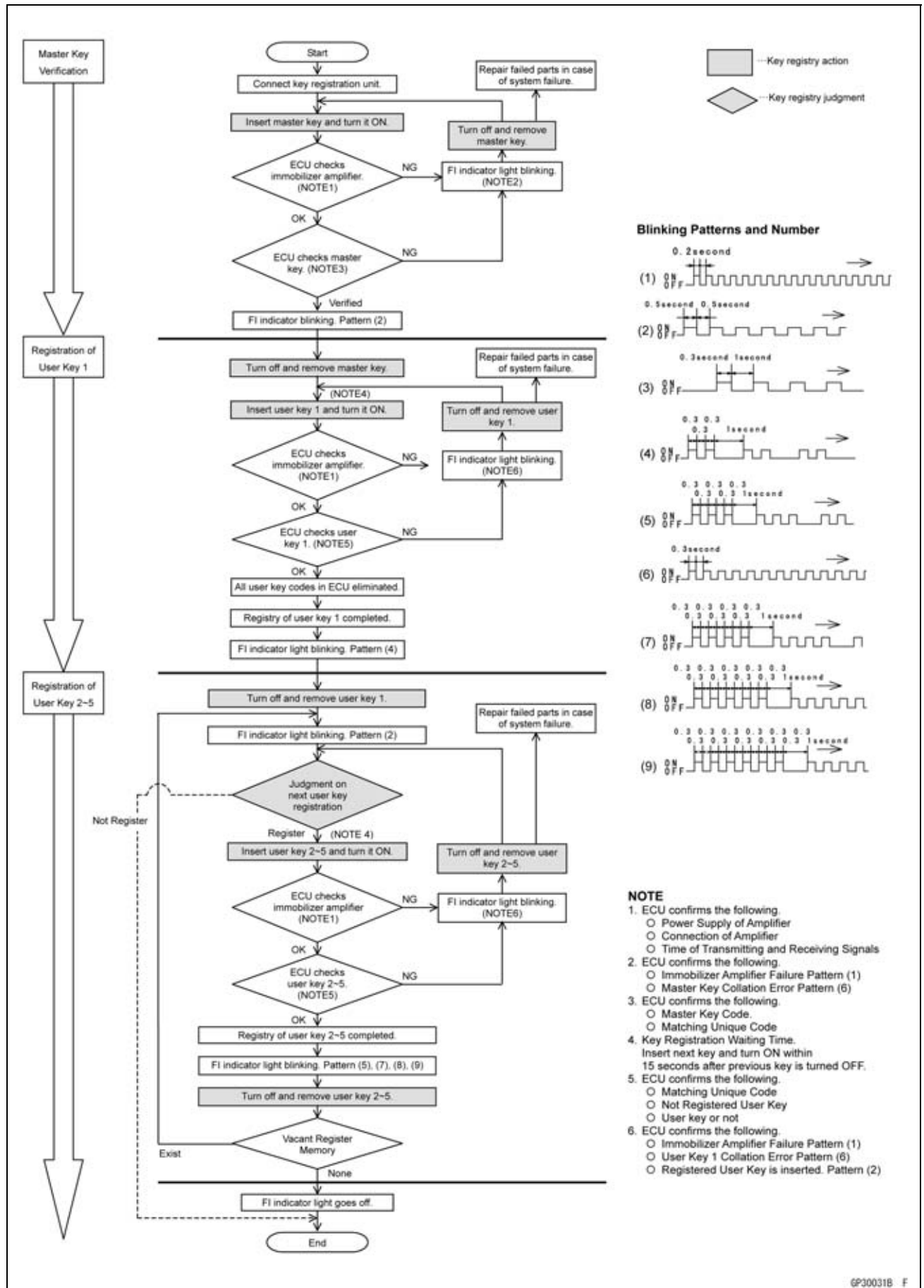

## 16-80 ELECTRICAL SYSTEM

### Immobilizer System (Equipped Models)

**Case 2: When the ignition switch is faulty and to be replaced.**

- Prepare a new ignition switch [A] and two new user keys [B].
- These parts are available as a set. Prepare the current master key [C].

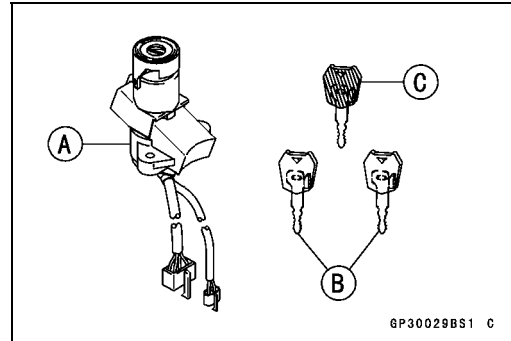

- Remove:
    - Ignition Switch and Immobilizer Antenna (see Immobilizer System Parts Replacement in this chapter)
    - Front Seat (see Front Seat Removal in the Frame chapter)
  - Disconnect the immobilizer/Kawasaki self-diagnostic system connector.
  - Connect the key registration unit [A].
- Special Tool - Key Registration Unit: 57001-1582**



- Connect:
  - New Ignition Switch Lead Connector [A]
  - Immobilizer Antenna Lead Connector [B]

#### NOTE

○ Keep the antenna more than 15 cm from the ignition switch.

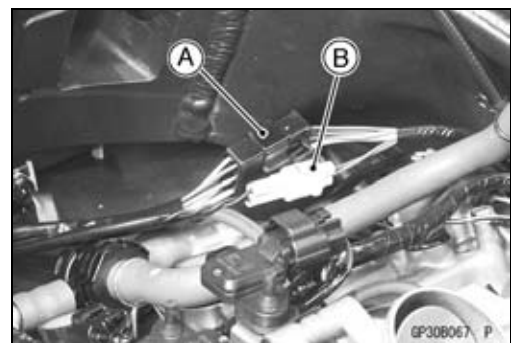

- Put the current master key [A] at the antenna [B]. Insert the new user key 1 [C] to the new ignition switch [D] and turn it ON.

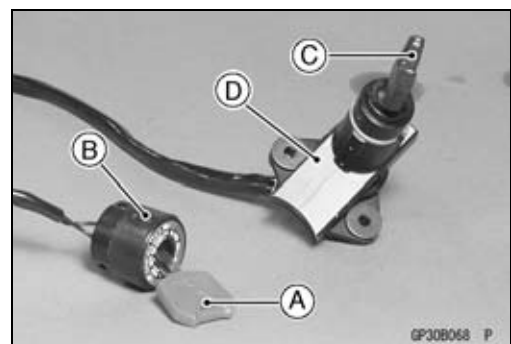

#### Verified

○ The FI indicator light [A] blinks to display the ECU is in the registration mode (go to the next step).

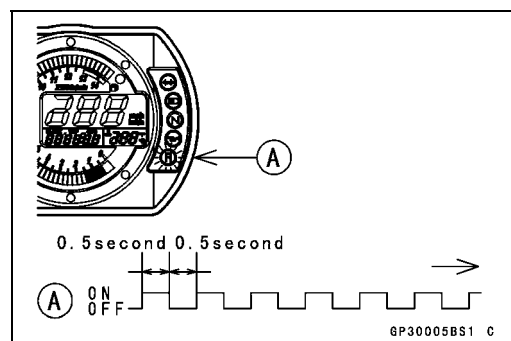

## Immobilizer System (Equipped Models)

### Not Verified

- The FI indicator light [A] blinks to display the collation error.

Immobilizer Amplifier Failure

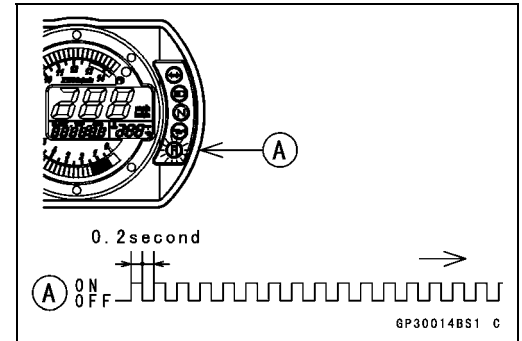

Master Key Collation Error

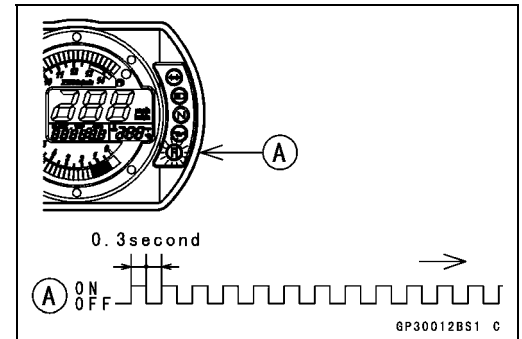

- Turn off and remove the new user key 1.
- Temporarily place the antenna [A] on the new ignition switch [B].
- Insert the user key 1 [C] again into the new ignition switch and turn it ON.

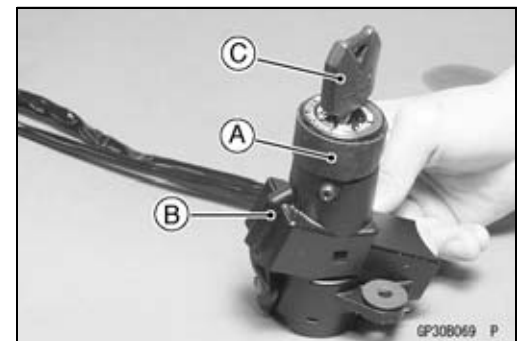

### NOTE

- Place the antenna on the ignition switch, insert the next key and turn ON within 15 seconds after previous key is turned off and removed otherwise registration mode will be ended and the FI indicator light stops flashing.
- To return to the registration mode start the master key verification procedure. This applies to all user key registration.
- Keep other user keys away from the immobilizer antenna.

- If there is any problem in the registration, the FI indicator light [A] blinks to display the collation error.

Immobilizer Amplifier Failure

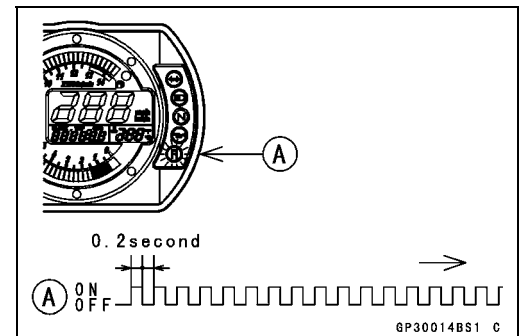

# 16-82 ELECTRICAL SYSTEM

## Immobilizer System (Equipped Models)

When Registered User Key is Inserted.

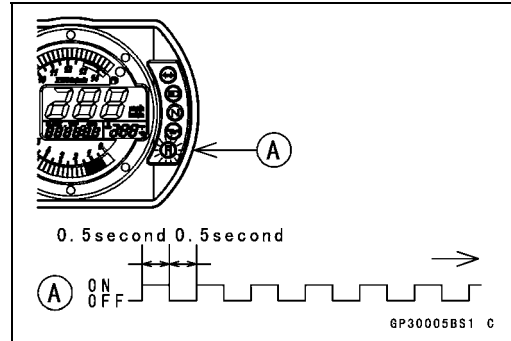

User Key Collation Error

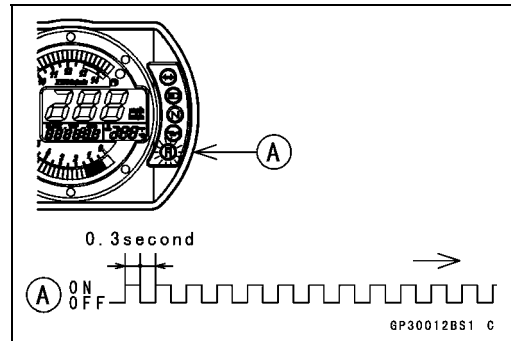

- The user key 1 is successfully registered in the ECU.
- The FI indicator light [A] blinks 2 times and stops for 1 second and then repeats this cycle to indicate successful registering of user key 1.

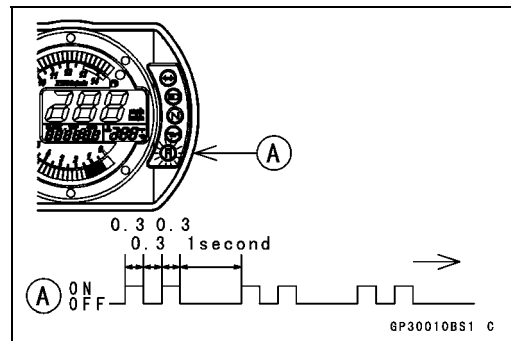

- Turn off and remove user key 1.
- The FI indicator light [A] blinks to display the registration mode.

### NOTE

- Turn off the ignition switch and wait for the period more than 15 seconds. The registration mode automatically ends and FI indicator light goes off.
  - This procedure has , registered the master key and one user key.
  - Continue the procedure to program the second and later keys.
- Insert the user key 2 to the ignition switch and turn it ON.

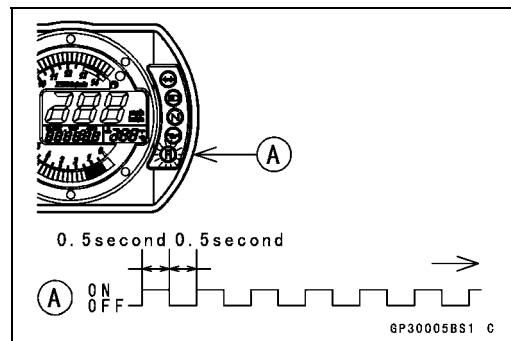

**Immobilizer System (Equipped Models)**

○ If there is any problem in the registration, the FI indicator light [A] blinks to display the collation error.  
Immobilizer Amplifier Failure

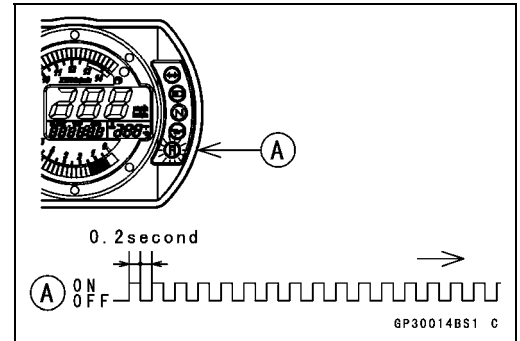

When Registered User Key is Inserted.

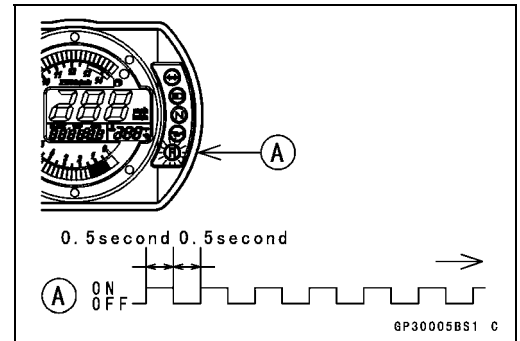

User Key Collation Error

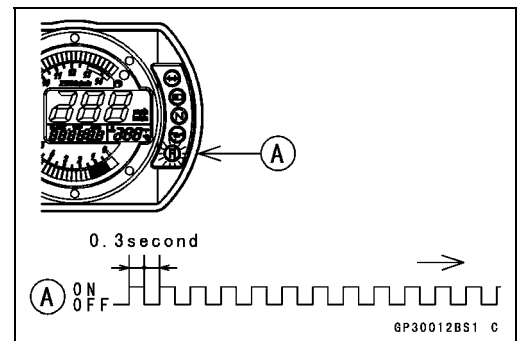

- The user key 2 is successfully registered in the ECU.
- The FI indicator light [A] blinks 3 times and stops for 1 second and then repeat this cycle to indicate successful programming of user key 2.
- Turn OFF the ignition switch and wait for period more than 15 seconds.
- The registration mode automatically ends.

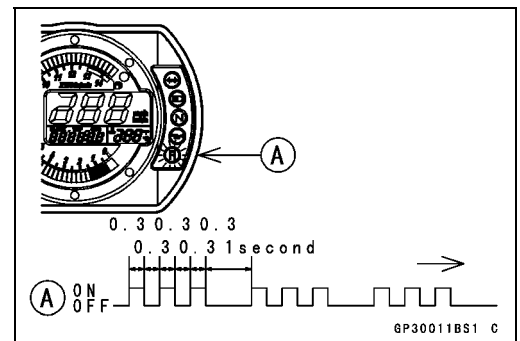

- FI indicator light goes off [A].

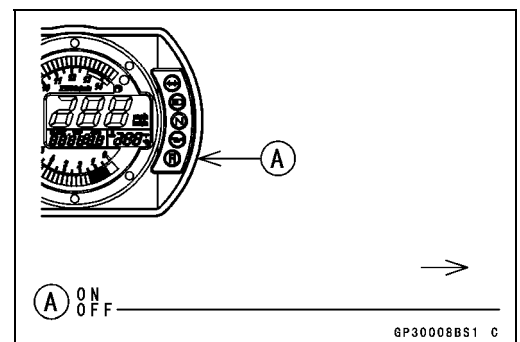

# 16-84 ELECTRICAL SYSTEM

## Immobilizer System (Equipped Models)

- Remove the key registration unit and connect the immobilizer/Kawasaki self-diagnostic system connector.

### NOTE

- Turn the ignition switch ON with the registered user key.
- Check that the engine can be started using all registered user keys.

- Install the new ignition switch and antenna.

### Case 3: When the electric control unit (ECU) is faulty and has to be replaced.

- Prepare a new ECU [A], current master key [B] and current user keys [C].

### NOTE

- The key registration unit is not required.

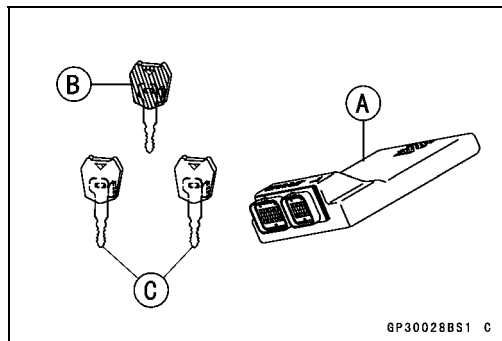

- Replace:  
Electric Control Unit [A] (see Immobilizer System Parts Replacement in this chapter)

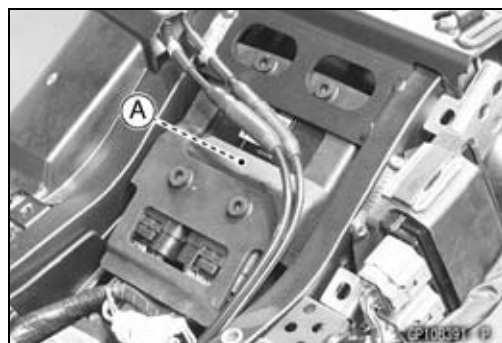

- Insert the current master key into the ignition switch and turn it ON.

- If there is any problem in the registration, the FI indicator light [A] blinks to display the collation error.  
Immobilizer Amplifier Failure

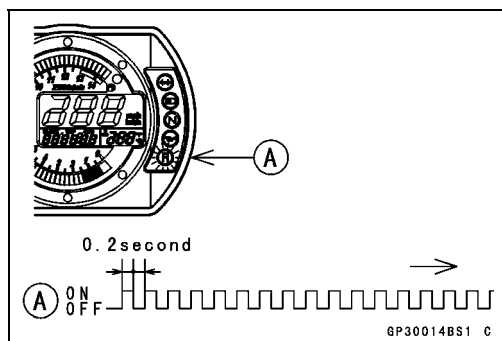

### Master Key Collation Error

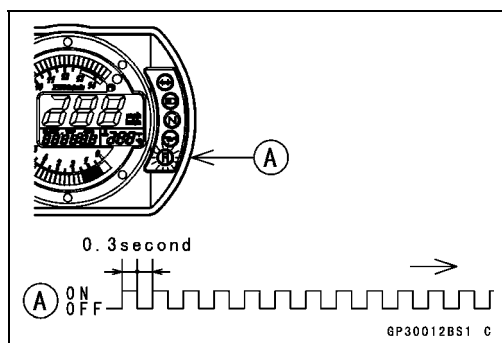

## Immobilizer System (Equipped Models)

- The master key is registered in the ECU.
- The FI indicator light [A] blinks 1 time and stops for 1 second and the repeats this cycle to indicate successful registration of the master key.

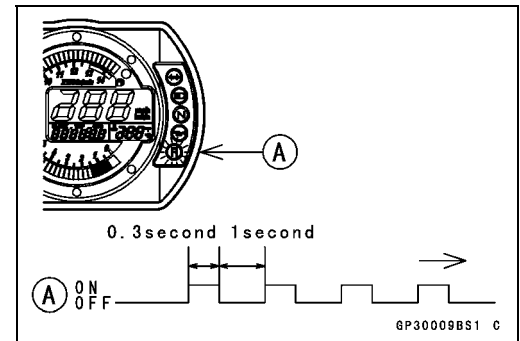

- Turn of the master key and remove it.
- The FI indicator light [A] blinks to display the registration mode.

### NOTE

- Insert next key and turn ON within 15 seconds after previous key is turned off and removed otherwise registration mode will be ended and the FI indicator light goes off.
- To return to the registration mode start the master key verification procedure. This applies to all user key registration.

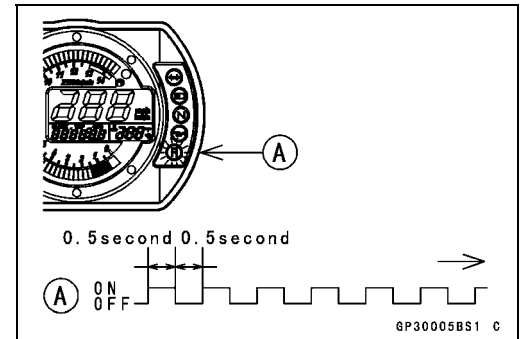

- Insert the user key 1 to the ignition switch and turn it ON.

### NOTE

- Keep the other user keys away from the immobilizer antenna.
- If there is any problem in the registration, the FI indicator light [A] blinks to display the collation error. Immobilizer Amplifier Failure

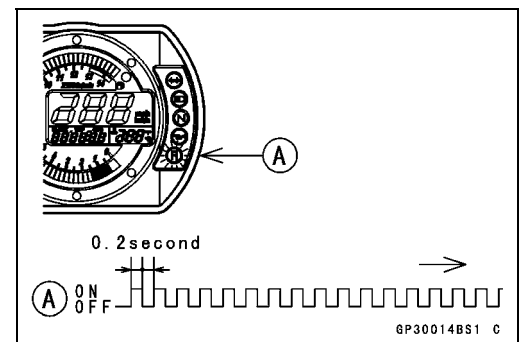

When Registered User Key is Inserted.

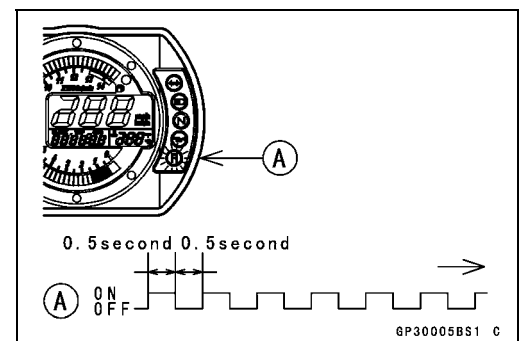

# 16-86 ELECTRICAL SYSTEM

## Immobilizer System (Equipped Models)

### User Key Collation Error

- The user key 1 is registered in the ECU.
- The FI indicator light [A] blinks 2 times and stops for 1 second and then repeats this cycle to indicate successful registration of user key.

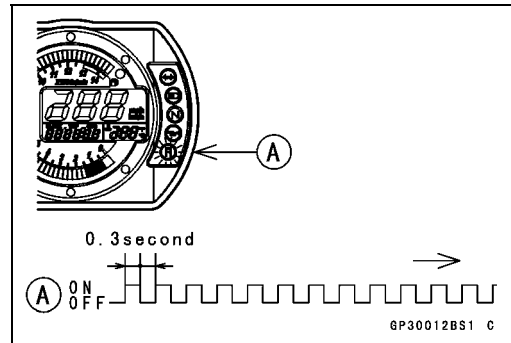

- Turn off and remove the user key 1.
- The FI indicator light [A] blinks to display the registration mode codes.

### NOTE

- Insert next key and turn ON within 15 seconds after previous key is turned off and removed otherwise registration mode will be ended and the FI indicator light goes off.
  - To return to the registration mode start the master key verification procedure. This applies to all user key registration.
- Insert the user key 2 to the ignition switch and turn it ON.
  - If there is any problem in the registration, the FI indicator light [A] blinks to display the collation error code.  
Immobilizer Amplifier Failure

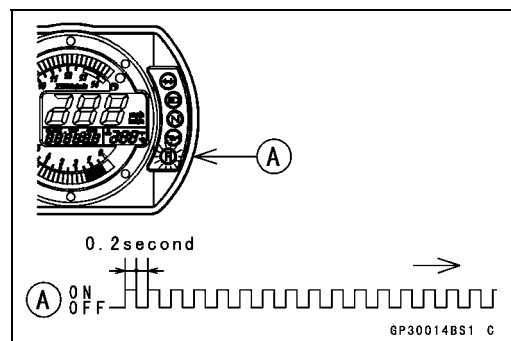
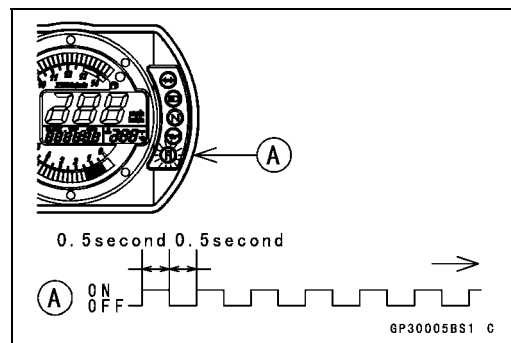
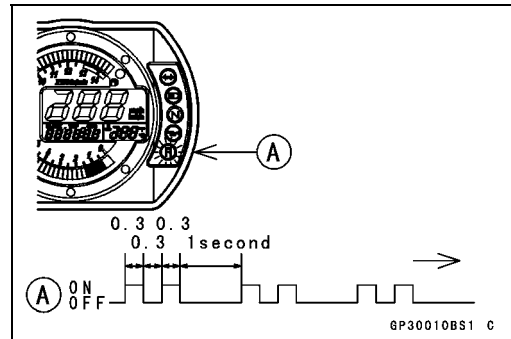

## Immobilizer System (Equipped Models)

When Registered User Key is Inserted.

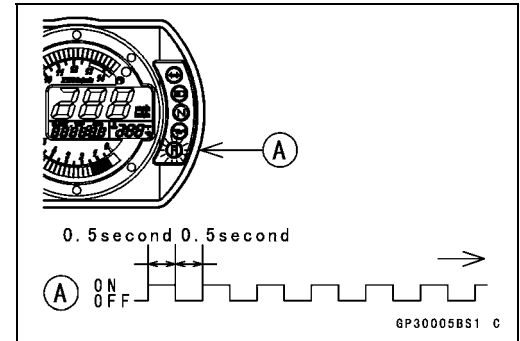

User Key Collation Error

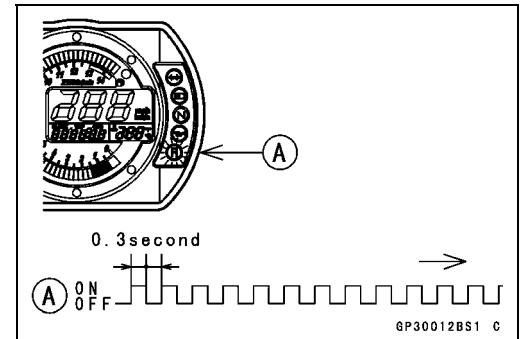

- The user key 2 is registered in the ECU.
- The FI indicator light [A] blinks 3 times and stops for 1 second and then repeats this cycle to indicate successful registration of user key 2.
- Turn OFF the ignition switch and wait for period more than 15 seconds.
- The registration mode automatically ends.

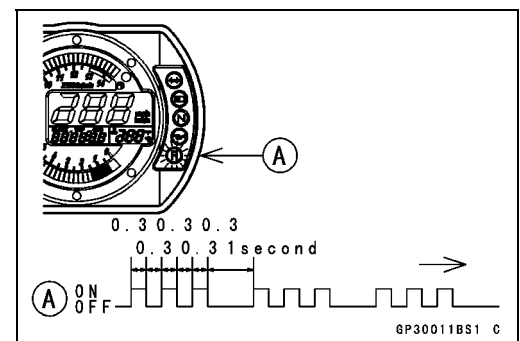

- FI indicator light goes off [A].

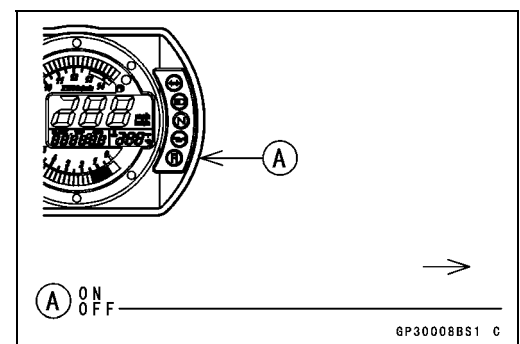

### NOTE

- Turn the ignition switch ON with the registered user key.
- Check that the engine can be started using all registered user keys.

### Case 4: When master key is faulty or lost.

The master key replacement is considered very rare case. However if it is required, the following is necessary.

### NOTE

- The ECU must be replaced with a new one because the master key code that is registered in the current ECU can not be rewritten.

## 16-88 ELECTRICAL SYSTEM

### Immobilizer System (Equipped Models)

- Prepare a new ECU [A], new master key [B] and current user keys [C].

#### NOTE

- The key registration unit is not required.
- The key registration process is same as the electric control unit replacement.

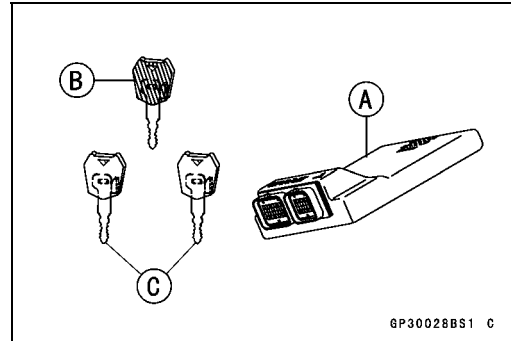

#### Case 5: When replacing the antenna.

- Prepare a new antenna.
- Refer to the Immobilizer System Parts Replacement in this chapter.

#### NOTE

- No key registration is required.

Immobilizer System (Equipped Models)

All Keys Initial Registration Flow Chart

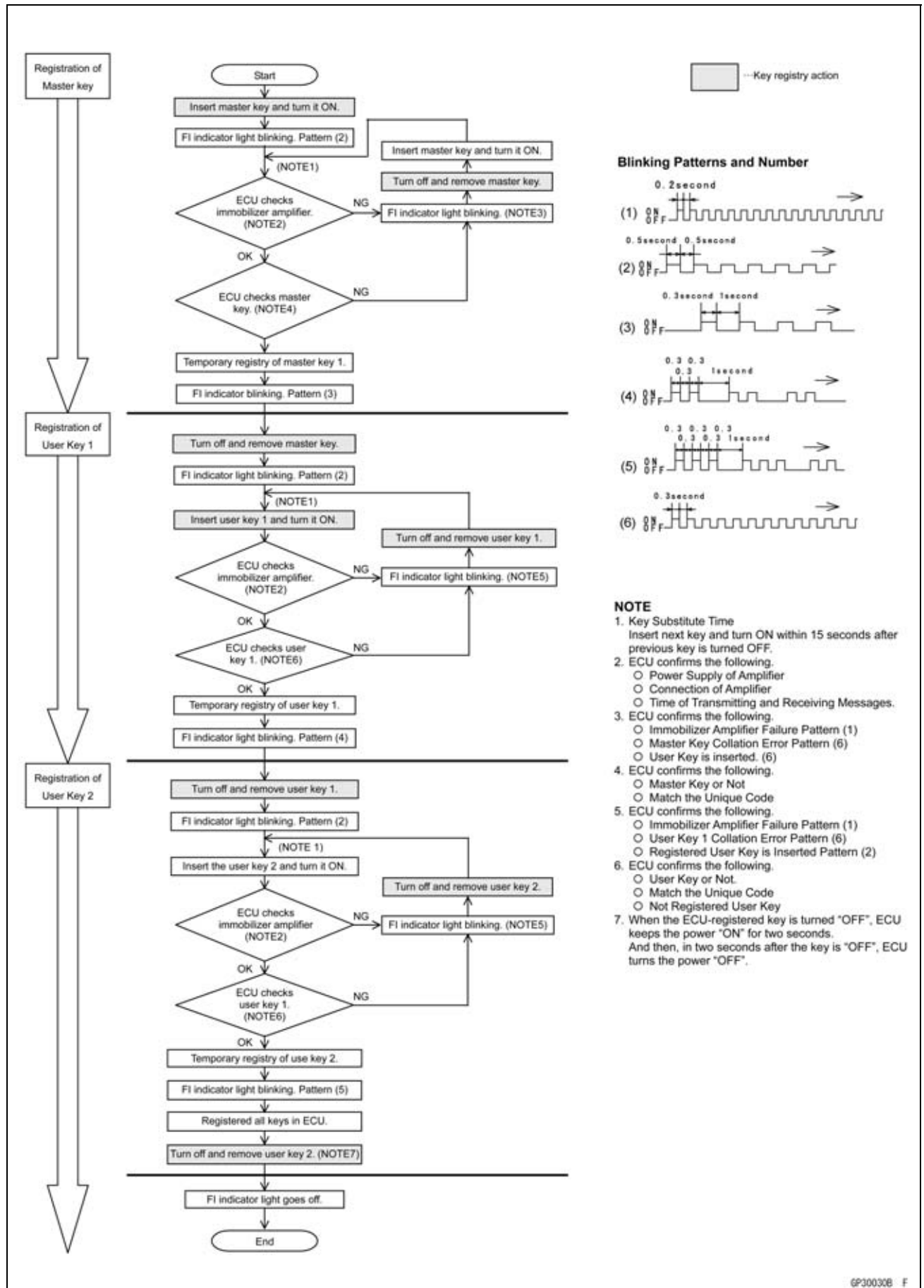

## 16-90 ELECTRICAL SYSTEM

### Immobilizer System (Equipped Models)

#### Immobilizer System Parts Replacement

##### Immobilizer Antenna

- Remove:
  - Air Cleaner Housing (see Air Cleaner Housing Removal in the Fuel System (DFI) chapter)
- Disconnect the lead connectors [A].

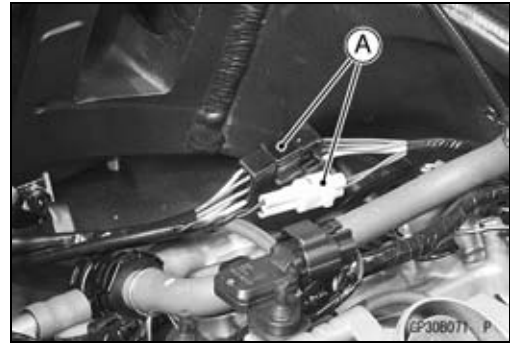

- Remove:
  - Steering Stem Head and Handlebar (see Handlebar Removal in the Steering chapter)
- Using a small chisel [A] or punch, turn out the Torx bolts.



- Cut the band [A].
- Remove the screw [B].
- Remove the antenna [C] with the cover [D].
- Pull the lower parts [E] of the cover outside to clear the projection [F] of the ignition switch.

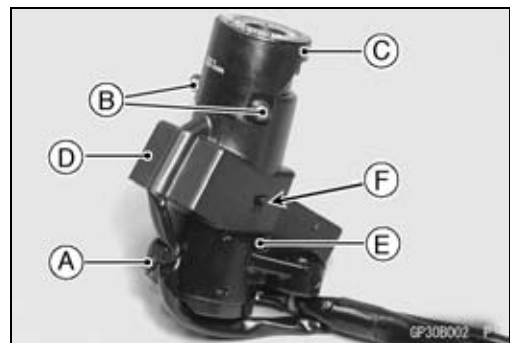

- Tighten a new Torx bolt [A] until the bolt head [B] is broken [C].
- Run the leads correctly (see Cable, Wire, and Hose Routing section in the Appendix chapter).

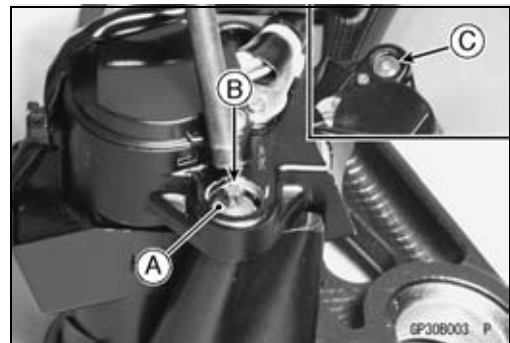

##### Immobilizer Amplifier Replacement

- Remove:
  - Right Center Fairing (see Center Fairing Removal in the Frame chapter)
- Remove the screws [A].

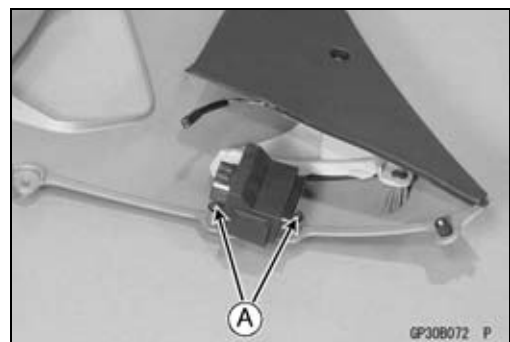

**Immobilizer System (Equipped Models)**

**ECU (Electric Control Unit) Replacement (for European Model)**

- Remove:
  - Seat Cover (see Seat Cover Removal in the Frame chapter)
- Using a small chisel or other suitable tool, turn out the screws [A].
- Remove the bolt [B] and guard bracket [C].
- Remove the ECU.

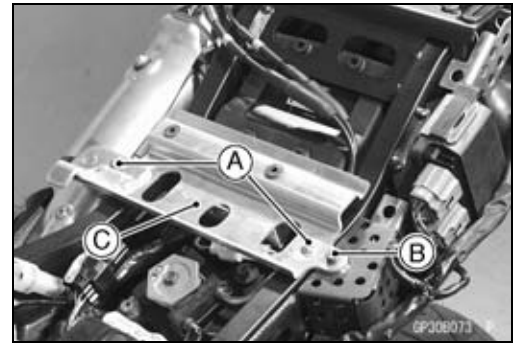

- Connect the connectors [A].

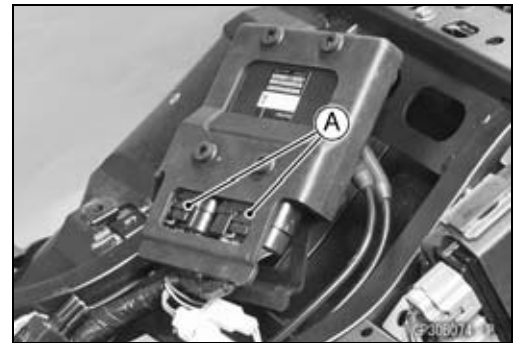

- Install:
  - Guard Bracket [A]

<b>CAUTION</b>
<b>Do not pinch the leads.</b>

- Tighten new screws [B] use Kawasaki genuine screws of which threads are coated with locking agent.

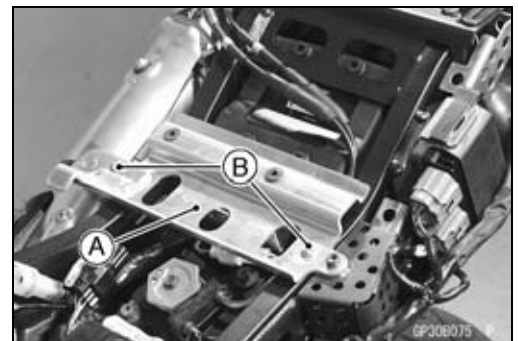

**Immobilizer Relational Parts Replacement Chart**

		Failed or Lost Part					
		Master Key (Red)	User Key (Black)	Ignition Switch	Antenna	Amplifier	ECU
*	Master Key (Red)	●					
	User Key (Black)		●	○			
	Ignition Switch			●			
	Antenna				●		
	Amplifier					●	
	ECU	○					●
*	Replacement Part						
●	Main Replacement Part						
○	Additional Replacement Part						

# 16-92 ELECTRICAL SYSTEM

## Immobilizer System (Equipped Models)

### Immobilizer System Inspection

- Refer to the Immobilizer Amplifier and Blank Key Detection section in the Fuel System (DFI) chapter.

### Immobilizer System Circuit

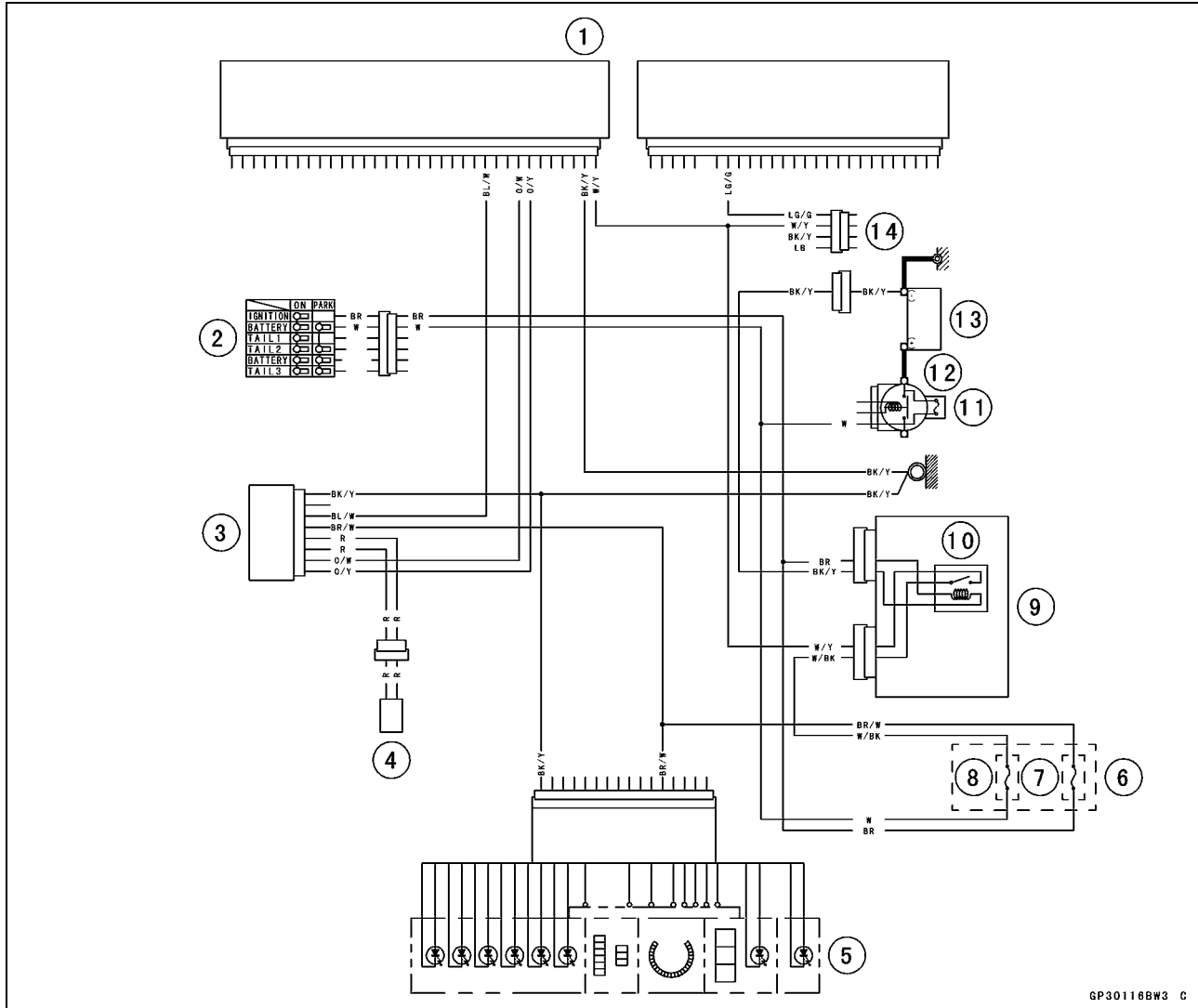

GP30116BW3 C

1. ECU
2. Ignition Switch
3. Immobilizer Amplifier
4. Immobilizer Antenna
5. Meter Unit
6. Fuse Box
7. Ignition Fuse 10 A
8. ECU Fuse 15 A
9. Relay Box
10. ECU Main Relay
11. Starter Relay
12. Main Fuse 30 A
13. Battery 12 V 8 Ah
14. Immobilizer/Kawasaki Self-diagnostic System Connector

## Switches and Sensors

### Brake Light Timing Inspection

- Refer to the Brake Light Switch Operation Inspection in the Periodic Maintenance chapter.

### Brake Light Timing Adjustment

- Refer to the Brake Light Switch Operation Inspection in the Periodic Maintenance chapter.

### Neutral Switch Replacement

#### CAUTION

**Never drop the neutral switch, especially on a hard surface.  
Such a shock to the neutral switch can damage it.**

- Drain the engine oil (see Engine Oil Change in the Periodic Maintenance chapter).
- Disconnect the neutral switch lead [A].
- Remove the neutral switch [B].
- Replace the gasket with a new one.

#### NOTE

○ *Two kinds of gaskets are available.*

- ★ If replacing the crankcase, shift drum related parts and neutral switch, install the washer of 1.5 mm (0.06 in.) thickness, and inspect the continuity (see Switch Inspection in this chapter).
- ★ If there is no continuity with 1.5 mm (0.06 in.) thickness washer, change the washer of 1.2 mm (0.05 in.) thickness, and install it.

Thickness	Part Number
1.5 mm (0.06 in.)	11060-1676
1.2 mm (0.05 in.)	11060-1684

- Apply a non-permanent locking agent to the threads of the neutral switch, and tighten it.

**Torque - Neutral Switch: 15 N·m (1.5 kgf·m, 11 ft·lb)**

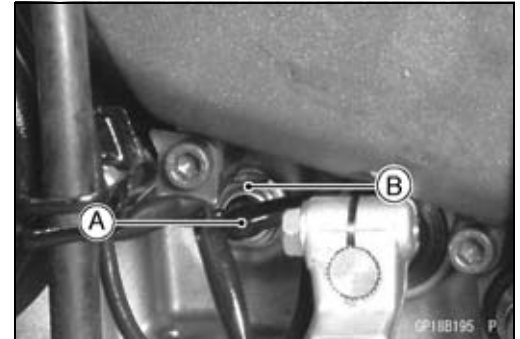

# 16-94 ELECTRICAL SYSTEM

## Switches and Sensors

### Switch Inspection

- Using a hand tester, check to see that only the connections shown in the table have continuity (about zero ohms).
- For the handlebar switches and the ignition switch, refer to the tables in the Wiring Diagram.
- ★ If the switch has an open or short, repair it or replace it with a new one.

**Special Tool - Hand Tester: 57001-1394**

### Rear Brake Light Switch Connections

	BR	BL
When brake pedal is pushed down	○ ——— ○	
When brake pedal is released		

### Side Stand Switch Connections

	G	BK
When side stand is up	○ ——— ○	
When side stand is down		

### Neutral Switch Connections

	SW. Terminal	TTT
When transmission is in neutral	○ ——— ○	
When transmission is not in neutral		

### Oil Pressure Switch Connections\*

	SW. Terminal	TTT
When engine is stopped	○ ——— ○	
When engine is running		

\*: Engine lubrication system is in good condition

## Switches and Sensors

### Water Temperature Sensor Inspection

- Remove the water temperature sensor (see Water Temperature Sensor Removal in the Fuel System (DFI) chapter).
- Suspend the sensor [A] in a container of coolant so that the temperature-sensing projection [E] and threaded portion [E] are submerged.
- Suspend an accurate thermometer [B] in the coolant.

#### NOTE

- The sensor and thermometer must not touch the container side or bottom.
- Place the container over a source of heat and gradually raise the temperature of the coolant while stirring the coolant gently.
- Using the hand tester, measure the internal resistance of the sensor.
- The sensor sends electric signals to the ECU (Electronic Control Unit) and coolant temperature gauge in the meter unit.
- Measure the resistance across the terminals and the body (for the gauge) at the temperatures shown in the table.
- ★ If the hand tester does not show the specified values, replace the sensor.

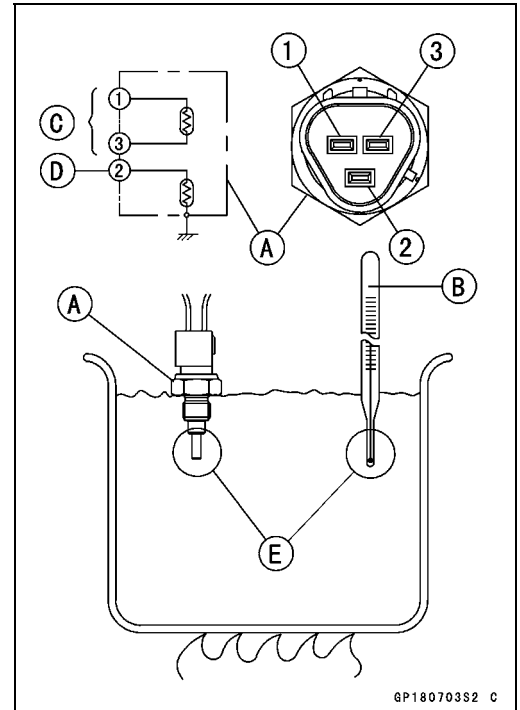

### Water Temperature Sensor

Resistance for ECU [C]	
Temperature	Resistance (kΩ) (Terminal [1]-[3])
20°C (68°F)	2.46 +0.115 -0.143
80°C (176°F)	0.32 ±0.011
110°C (230°F)	0.1426 ±0.0041

Resistance for Water Temperature Gauge [D]	
Temperature	Resistance (Ω) (Terminal [2]-Body)
50°C (122°F)	210 ±40
120°C (248°F)	21.2 ±1.5

### Speed Sensor Removal

- Remove:
  - Fuel Tank (see Fuel Tank Removal in the Fuel System (DFI) chapter)
- Disconnect the speed sensor lead connector [A].
- Remove the speed sensor bolt [B] and spacer.
- Remove the speed sensor [C].

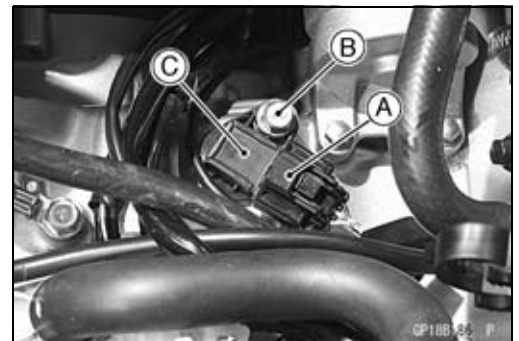

### Speed Sensor Installation

- Install the speed sensor.
  - Torque - Speed Sensor Bolt: 12 N·m (1.2 kgf·m, 104 in·lb)**

# 16-96 ELECTRICAL SYSTEM

## Switches and Sensors

### Speed Sensor Inspection

- Remove:
  - Speed Sensor (see Speed Sensor Removal in this chapter)
- Connect the speed sensor connector [A] with the battery [B], 10 kΩ resistor [C] and hand tester [D] as shown.
- Set the tester to the DC 25 V range.

**Special Tool - Hand Tester: 57001-1394**

- Trace [A] each side of the speed sensor surface with the screw driver.
- Then the tester indicator should flick [B].
- ★ If the tester indicator does not flick, replace the speed sensor.

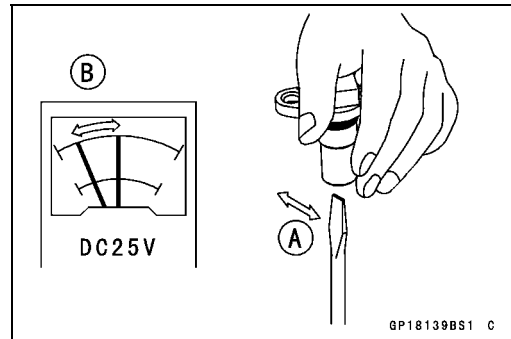
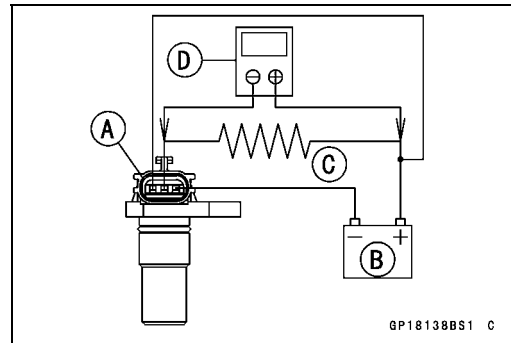

### Fuel Reserve Switch Inspection

- Fill the fuel tank with fuel.
- Close the fuel tank cap surely.
- Remove the fuel tank (see Fuel Tank Removal in the Fuel System (DFI) chapter).
- Connect the test light [A] (12 V 3.4 W bulb in a socket with leads) and the 12 V battery [B] to the fuel pump connector [C].

#### Connections

**Battery (+) → 12 V 3.4 W Bulb (one side)**

**12 V 3.4 W Bulb (other side) → R/BK Lead Terminal**

**Battery (-) → BK/W Lead Terminal**

**Special Tool - Needle Adapter Set: 57001-1457**

- ★ If the test light turn on, the reserve switch is defective. Replace the fuel pump.

- Remove:
  - Fuel Pump (see Fuel Pump Removal in the Fuel System (DFI) chapter)
- Connect the test light (12 V 3.4 W bulb in a socket with leads) and the 12 V battery to the fuel pump connector as shown.
  - 12 V Battery [A]
  - Test Light [B]
  - Fuel Pump Connector [C]
  - Fuel Reserve Switch [D]

- ★ If the test light doesn't light, replace the fuel pump.

#### NOTE

○ It may take a long time to turn on the test light in case that the fuel reserve switch is inspected just after the fuel pump is removed. Leave the fuel reserve switch with leads for inspection connected for few minutes.

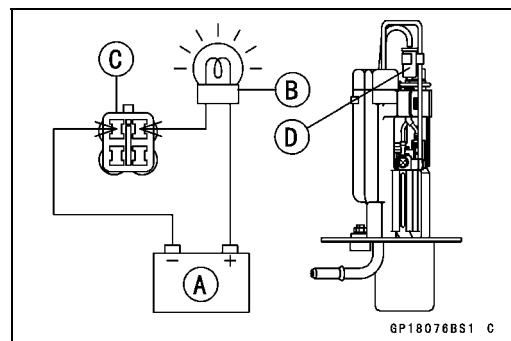
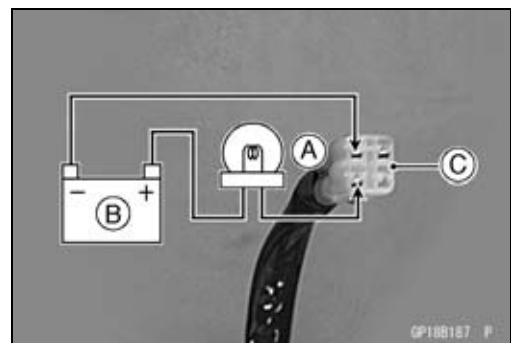

## Relay Box

The relay box [A] has relays and diodes. The relays and diodes can not be removed.



### Relay Box Removal

- Remove:
  - Seat Cover (see Seat Cover Removal in the Frame chapter)
- Take out the relay box [A] and disconnect the connectors [B].

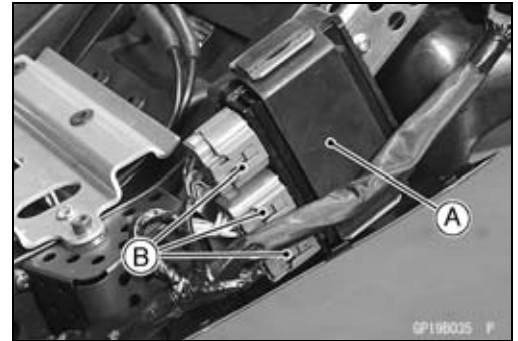

### Relay Circuit Inspection

- Remove the relay box (see Relay Box Removal in this chapter).
  - Check conductivity of the following numbered terminals by connecting the hand tester and one 12 V battery to the relay box as shown (see Relay Box Internal Circuit in this section).
- ★ If the tester does not read as specified, replace the relay box.

### Relay Circuit Inspection (with the battery disconnected)

	Tester Connection	Tester Reading ( $\Omega$ )
Headlight Relay	11-16	$\infty$
ECU Main Relay	12-13	$\infty$
	5-10	Not $\infty^*$
Fuel Pump Relay	12-14	$\infty$
	1-7	Not $\infty^*$
Starter Circuit Relay	6-9	$\infty$
	3-9	$\infty$
Fan Relay	17-19	$\infty$
	18-20	Not $\infty^*$

\*: The actual reading varies with the hand tester used.

# 16-98 ELECTRICAL SYSTEM

## Relay Box

### Relay Circuit Inspection (with the battery connected)

	Battery Connection		Tester Connection	Tester Reading ( $\Omega$ )
	(+)	(-)		
ECU Main Relay	15-9		11-16	0
	5-10		12-13	0
Fuel Pump Relay	7-1		12-14	0
Fan Relay	18-20		17-19	0

	Battery Connection		Tester Connection DC 25 V Range	Tester Reading (V)
	(+)	(-)		
Starter Circuit Relay	6-3		9-3	Battery Voltage

(+): Apply positive lead.  
(-): Apply negative lead.

### Diode Circuit Inspection

- Remove the relay box (see Relay Box Removal in this chapter).
- Check conductivity of the following pairs of terminals (see Relay Box Internal Circuit in this section).

### Diode Circuit Inspection

Tester Connection	2-3, 2-4, 3-4, 3-6, 4-8, 9-15, 9-16
-------------------	-------------------------------------

★ The resistance should be low in one direction and more than ten times as much in the other direction. If any diode shows low or high in both directions, the diode is defective and the relay box must be replaced.

### NOTE

○ The actual meter reading varies with the meter or tester used and the individual diodes, but generally speaking, the lower reading should be from zero to one half the scale.

Relay Box

Relay Box Internal Circuit

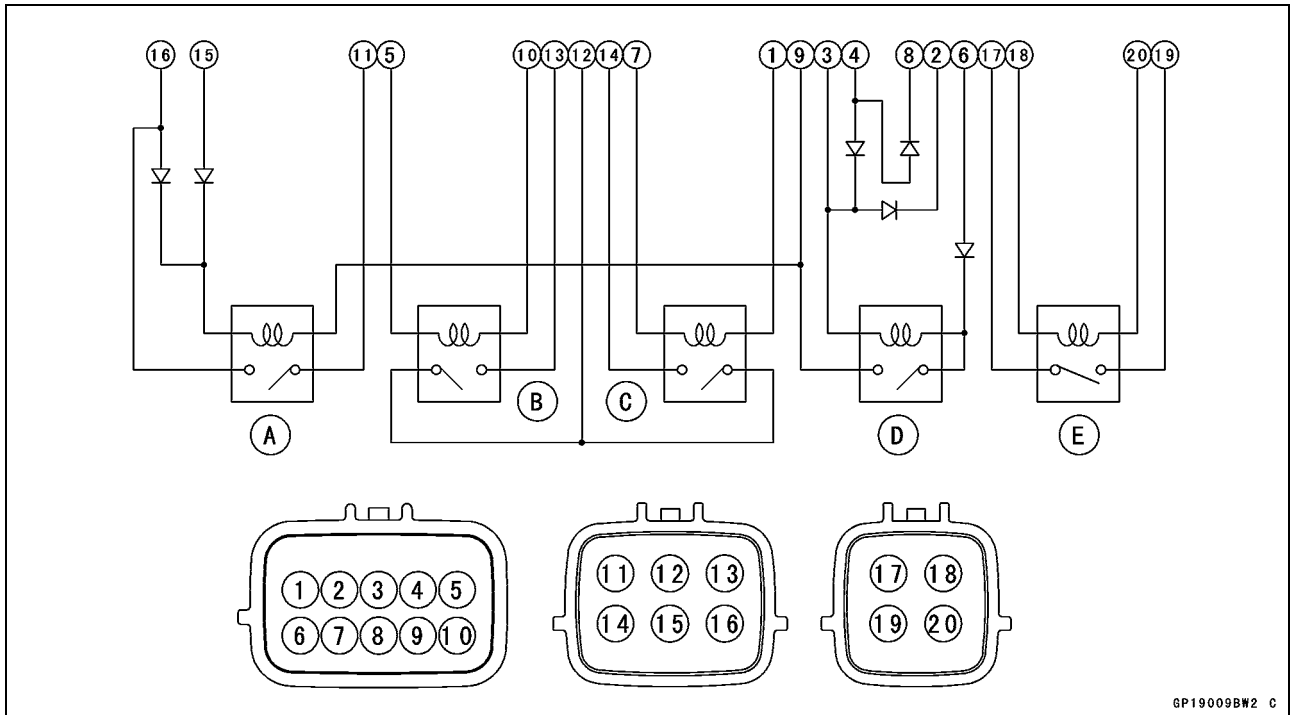

GP19009BW2 C

- A: Headlight Relay
- B: ECU Main Relay
- C: Fuel Pump Relay
- D: Starter Circuit Relay
- E: Fan Relay

## 16-100 ELECTRICAL SYSTEM

### Fuse

#### 30 A Main Fuse Removal

- Remove:
  - Left Side Cover (see Left Side Cover Removal in the Frame chapter)
  - 30 A Main Fuse Connector [A]
  
- Pull out the main fuse [A] from the starter relay with needle nose pliers.

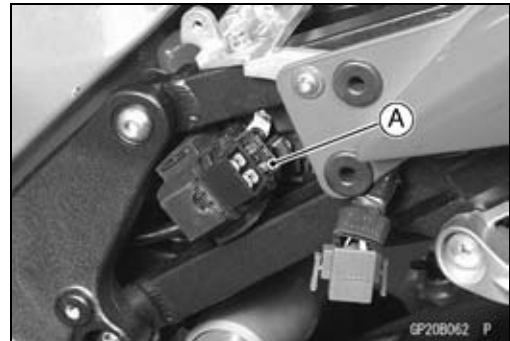
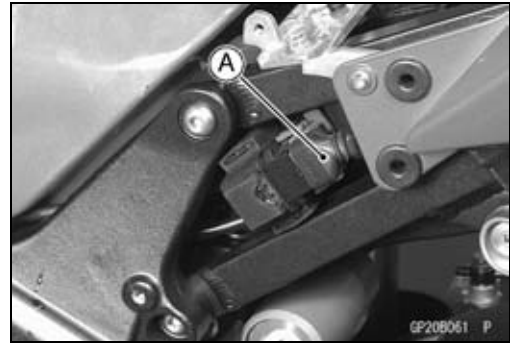

#### Fuse Box Fuse Removal

- Remove the rear seat (see Rear Seat Removal in the Frame chapter).
- Push the hook [A] to lift up the lid [B].



- Pull the fuses [A] straight out of the fuse box with needle nose pliers.

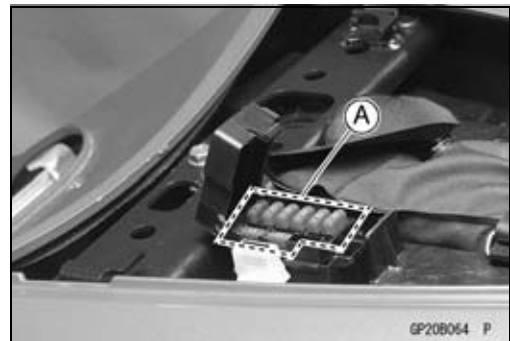

#### 15 A ECU Fuse Removal

- Remove:
  - Rear Seat (see Rear Seat Removal in the Frame chapter)
- Pull the hook [A] to lift up the lid [B]



## Fuse

- Pull the ECU fuse [A] straight out of the fuse box with needle nose pliers.

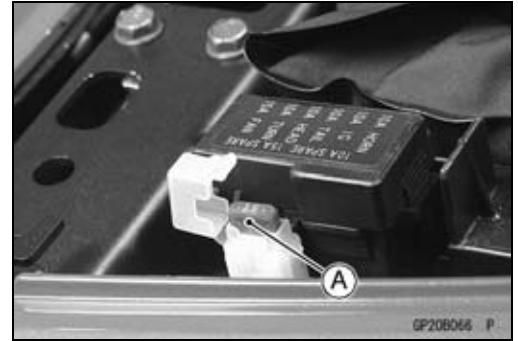

### Fuse Installation

- If a fuse fails during operation, inspect the electrical system to determine the cause, and then replace it with a new fuse of proper amperage.
- Install the fuse box fuses on the original position as specified on the lid.

### Fuse Inspection

- Remove the fuse (see Fuse Removal in this chapter).
- Inspect the fuse element.
- ★ If it is blown out, replace the fuse. Before replacing a blown fuse, always check the amperage in the affected circuit. If the amperage is equal to or greater than the fuse rating, check the wiring and related components for a short circuit.

Housing [A]

Fuse Element [B]

Terminals [C]

Blown Element [D]

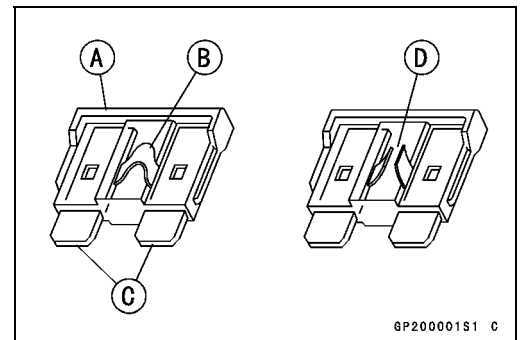

### CAUTION

**When replacing a fuse, be sure the new fuse matches the specified fuse rating for that circuit. Installation of a fuse with a higher rating may cause damage to wiring and components.**



# Appendix

## Table of Contents

Cable, Wire, and Hose Routing .....	17-2
Troubleshooting Guide .....	17-28

# 17-2 APPENDIX

## Cable, Wire, and Hose Routing

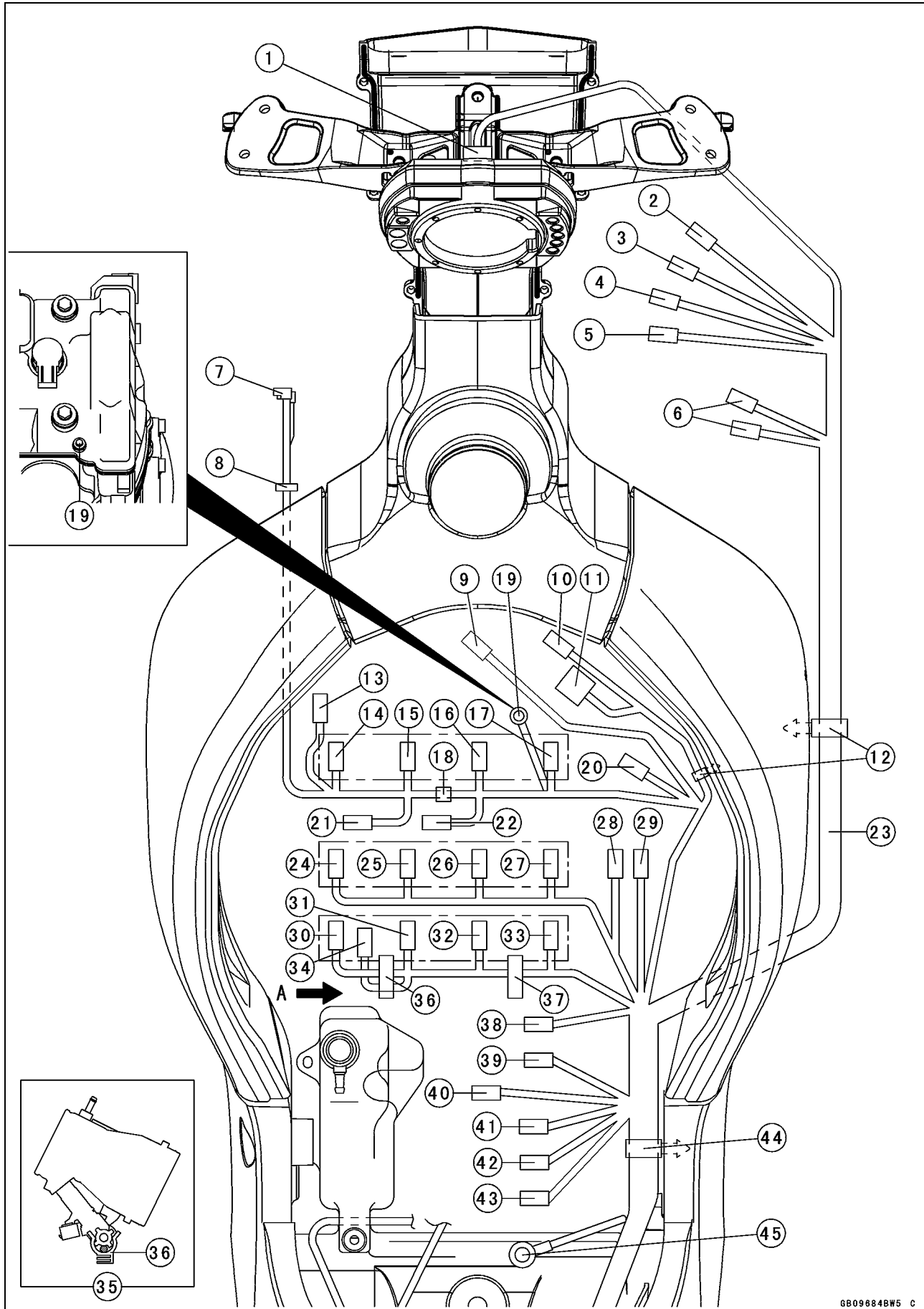

---

**Cable, Wire, and Hose Routing**

---

1. Meter Connector
2. Left Switch Housing Lead Connector
3. Front Right Turn Signal Light Connector
4. Headlight Harness Connector
5. Immobilizer Amplifier (Equipped Models)
6. Right Switch Housing Lead Connector
7. Horn Lead Connectors
8. Clamp the horn lead.
9. Camshaft Position Sensor Lead Connector
10. Immobilizer Antenna (Equipped Models)
11. Ignition Switch Lead Connector
12. Clamp
13. Radiator Fan Lead Connector
14. Stick Coil #1 Connector
15. Stick Coil #2 Connector
16. Stick Coil #3 Connector
17. Stick Coil #4 Connector
18. White Mark
19. Engine Ground
20. Subthrottle Sensor Connector
21. Inlet Air Pressure Sensor Connector
22. Atmospheric Pressure Sensor Connector
23. Main Harness
24. Secondary Fuel Injector #1 Connector
25. Secondary Fuel Injector #2 Connector
26. Secondary Fuel Injector #3 Connector
27. Secondary Fuel Injector #4 Connector
28. Inlet Air Temperature Sensor Connector
29. Main Throttle Sensor Connector
30. Primary Fuel Injector #1 Connector
31. Primary Fuel Injector #2 Connector
32. Primary Fuel Injector #3 Connector
33. Primary Fuel Injector #4 Connector
34. Water Temperature Sensor Connector
35. View A
36. Clamp
37. Clamp
38. Regulator/Rectifier Lead Connector
39. Subthrottle Valve Actuator Lead Connector
40. Speed Sensor Connector
41. Side Stand Switch Lead Connector
42. Engine Harness
43. Rear Brake Light Switch Lead Connector
44. Clamp
45. Frame Ground

# 17-4 APPENDIX

## Cable, Wire, and Hose Routing

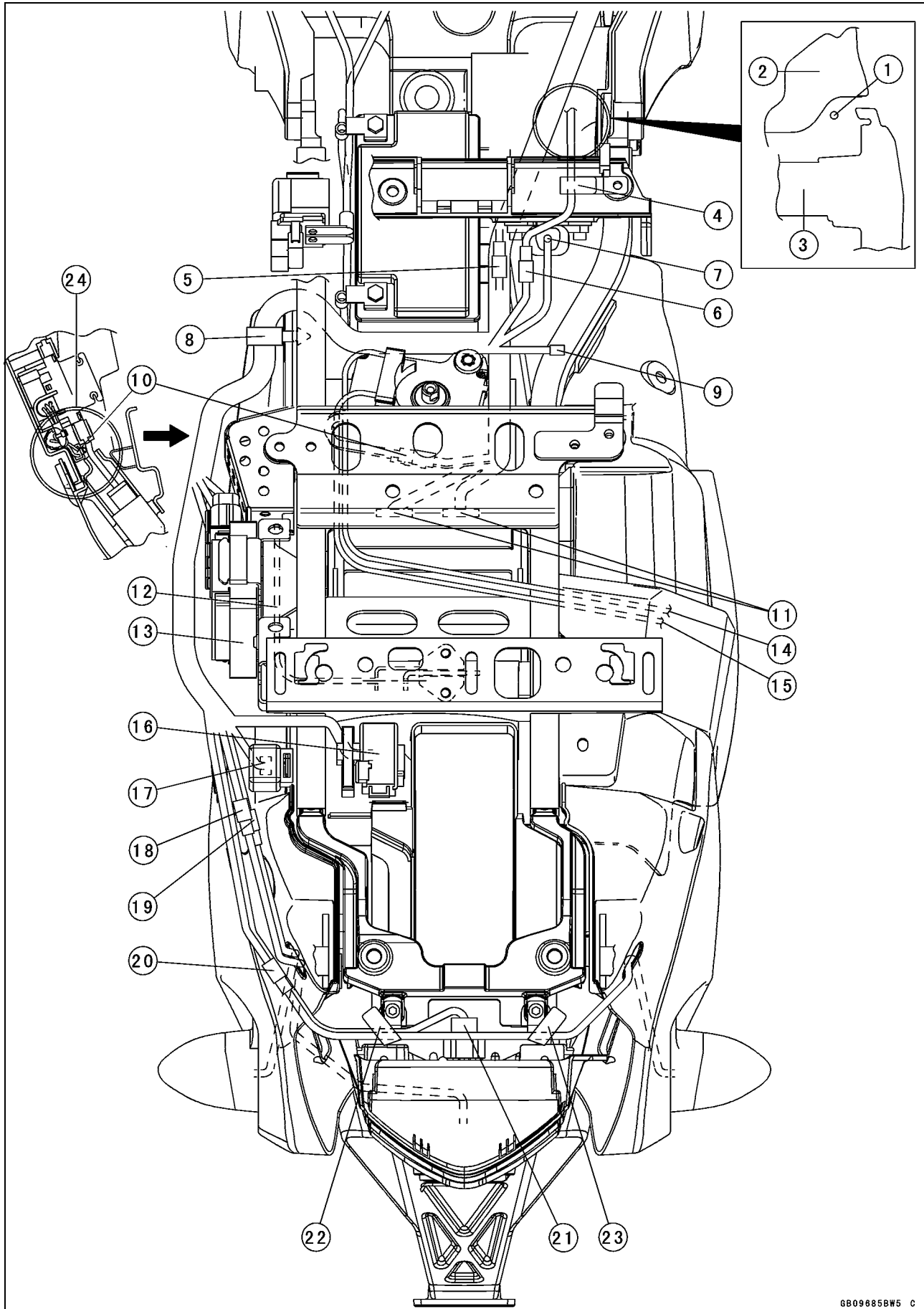

---

**Cable, Wire, and Hose Routing**

---

1. Fuel Pump Lead
2. Fuel Tank
3. Frame
4. Clamp
5. Immobilizer/Kawasaki Diagnosis System Connector
6. Fuel Pump Lead Connector
7. Vehicle-down Sensor Lead Connector
8. Clamp
9. Self-diagnosis Indicator Terminal
10. Exhaust Butterfly Valve Actuator Lead Connector
11. ECU Connectors
12. Seat Lock Cable
13. Relay Box
14. Exhaust Butterfly Valve Cable (Accelerator)
15. Exhaust Butterfly Valve Cable (Decelerator)
16. Fuse Box
17. Turn Signal Relay Connector
18. Licence Plate Light Connector
19. Rear Left Turn Signal Light Connector
20. Rear Right Turn Signal Light Connector
21. Tail/Brake Light Connector
22. Clamp the together with tail/brake and rear turn signal light lead.
23. Clamp

# 17-6 APPENDIX

## Cable, Wire, and Hose Routing

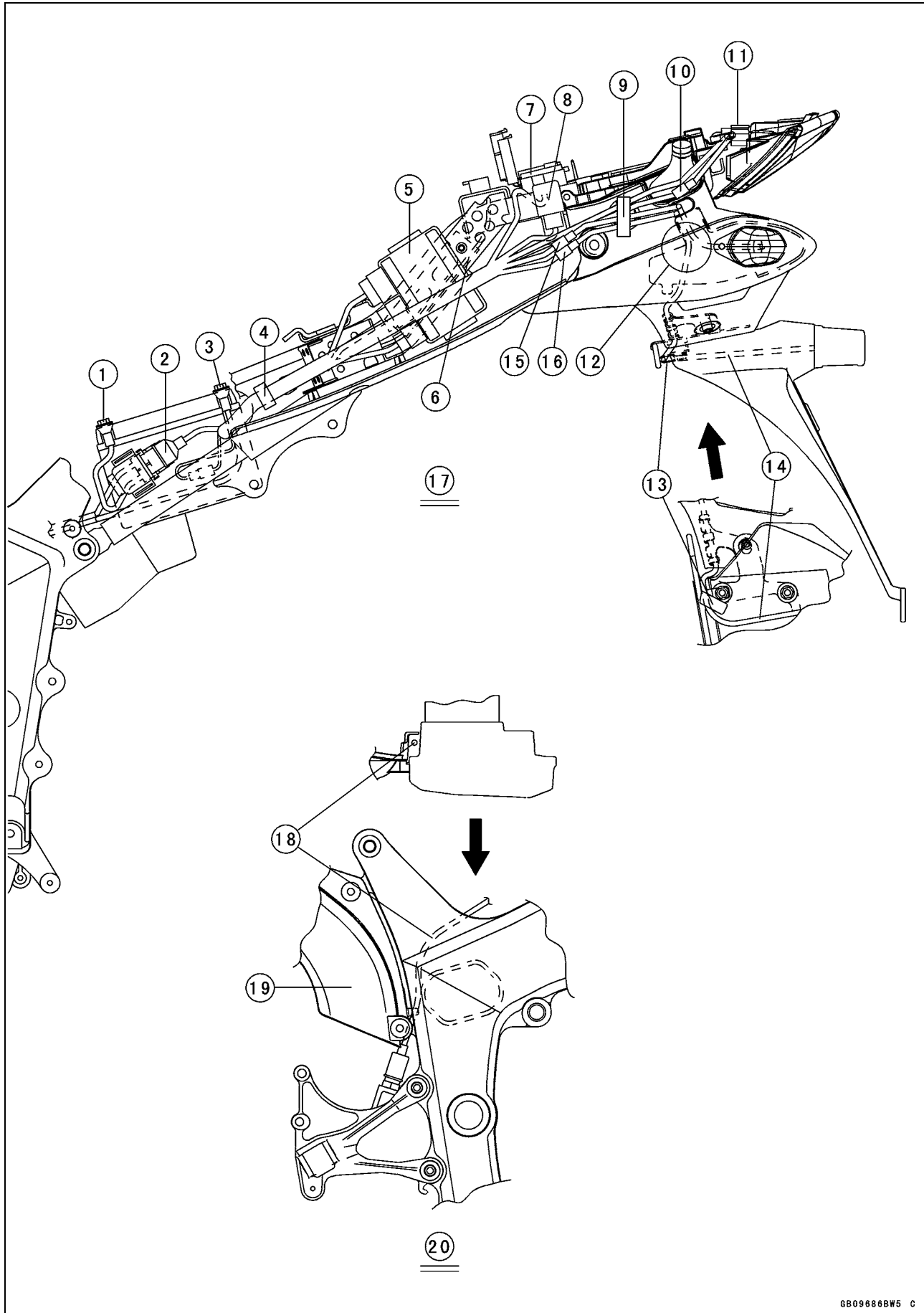

---

**Cable, Wire, and Hose Routing**

---

1. Battery Positive Terminal
2. Starter Relay
3. Battery Negative Terminal
4. Clamp
5. Relay Box
6. Run the seat lock cable into the relay box bracket.
7. Fuse Box
8. Turn Signal Relay
9. Clamp
10. Rear Right Turn Signal Light Connector
11. Tail/Brake Light Connector
12. Run the licence plate light and rear left turn signal light lead into the left turn signal light cover.
13. Clamp
14. Licence Plate Light Lead
15. Rear Left Turn Signal Light Connector
16. Licence Plate Light Connector
17. Left Side View
18. Run the rear brake light switch lead between front frame and cover.
19. Cover
20. Right Side View

# 17-8 APPENDIX

## Cable, Wire, and Hose Routing

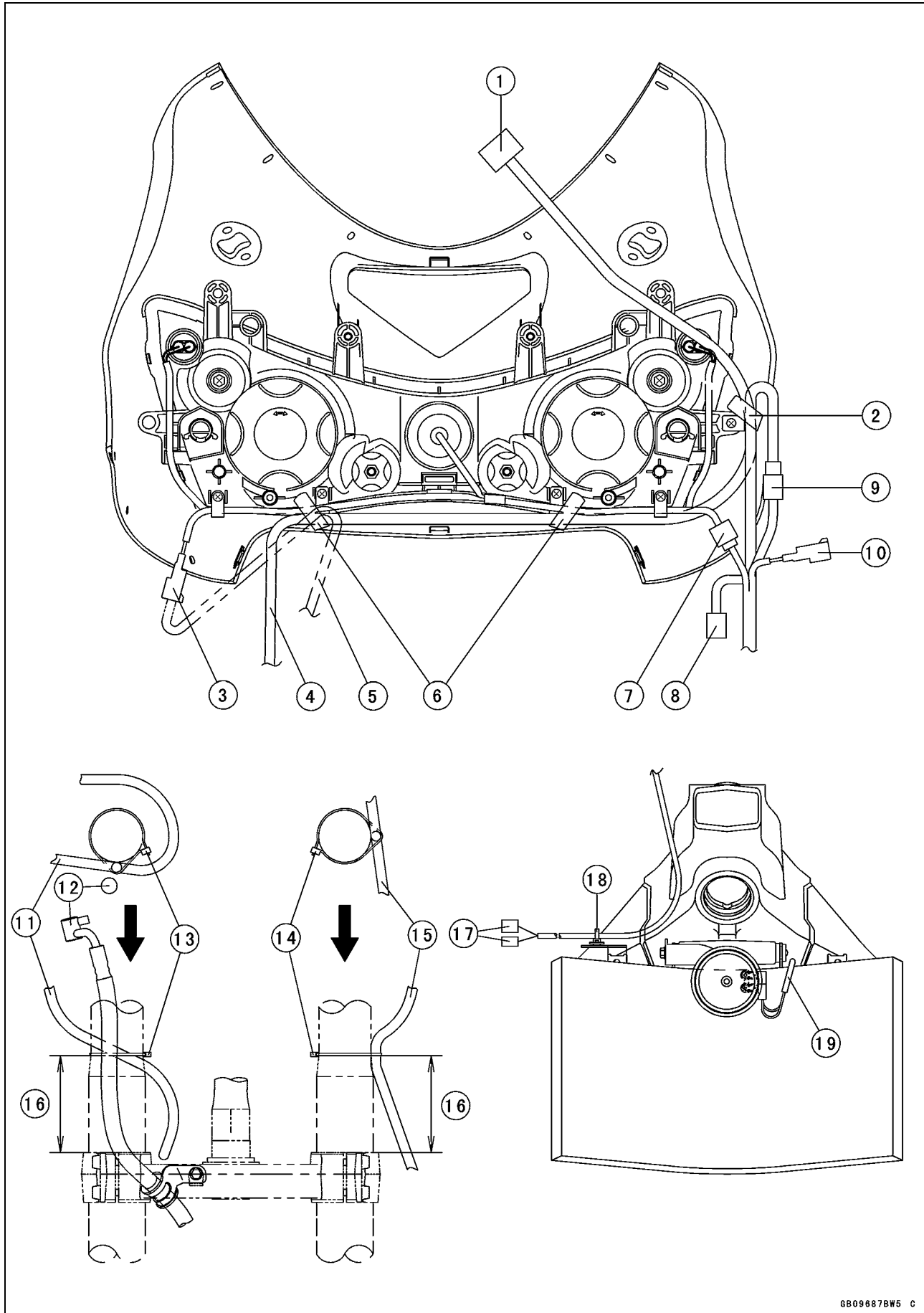

---

**Cable, Wire, and Hose Routing**

---

1. Meter Connector
2. Clamp the meter connector and front turn signal light connector.
3. Front Left Turn Signal Light Connector
4. Left Switch Housing Lead
5. United States, Canada and California Model only
6. Clamps
7. Headlight Connector
8. Immobilizer Amplifier (Equipped Models)
9. Front Right Turn Signal Light Connector
10. Front Right Turn Signal Light Connector
11. Right Switch Housing Lead
12. Front Brake Hose
13. Band
14. Band
15. Left Switch Housing Lead
16. Approx. 72 mm (2.8 in.)
17. Right Switch Housing Lead Connector
18. Band
19. Run the horn lead between frame and radiator.

# 17-10 APPENDIX

## Cable, Wire, and Hose Routing

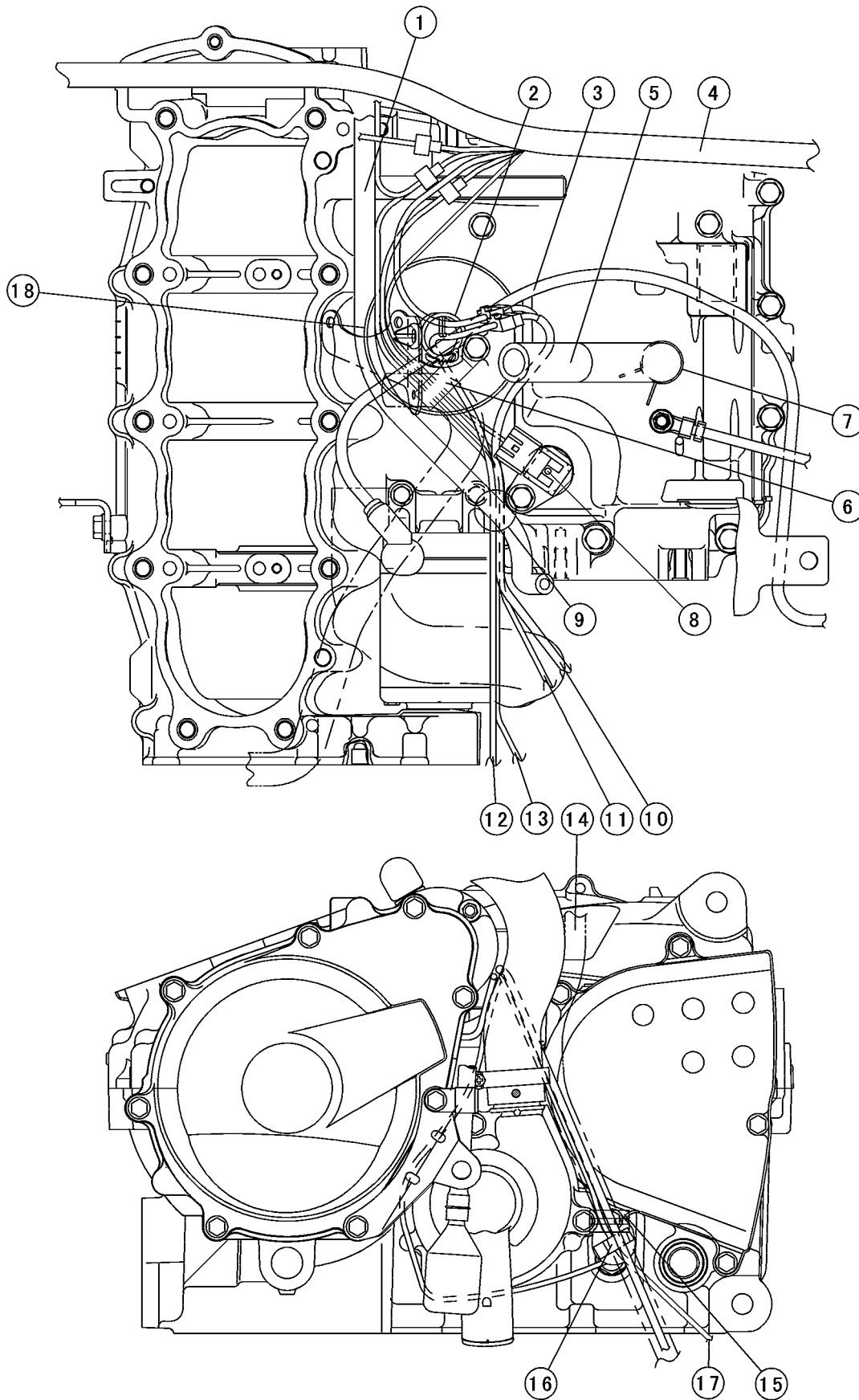

---

**Cable, Wire, and Hose Routing**

---

1. Reserve Return Hose
2. Clamp
3. Starter Motor Cable
4. Main Harness
5. Run the harnesses under the breather hose.
6. Clamp
7. Clamp
8. Speed Sensor
9. Force the harness into between the bosses of the upper crankcase.
10. Regulator/Rectifier Lead
11. Side Stand Switch Lead
12. Alternator Lead
13. Neutral Switch Lead
14. Reserve Tank Over Flow Hose
15. Clamp the regulator/rectifier lead together with the fuel tank drain hose and reserve tank over flow hose.
16. Clamp the side stand switch lead.
17. Adjust the clamp position so that the side stand lead does not loosen.
18. Run the alternator lead under the starter motor cable.

# 17-12 APPENDIX

## Cable, Wire, and Hose Routing

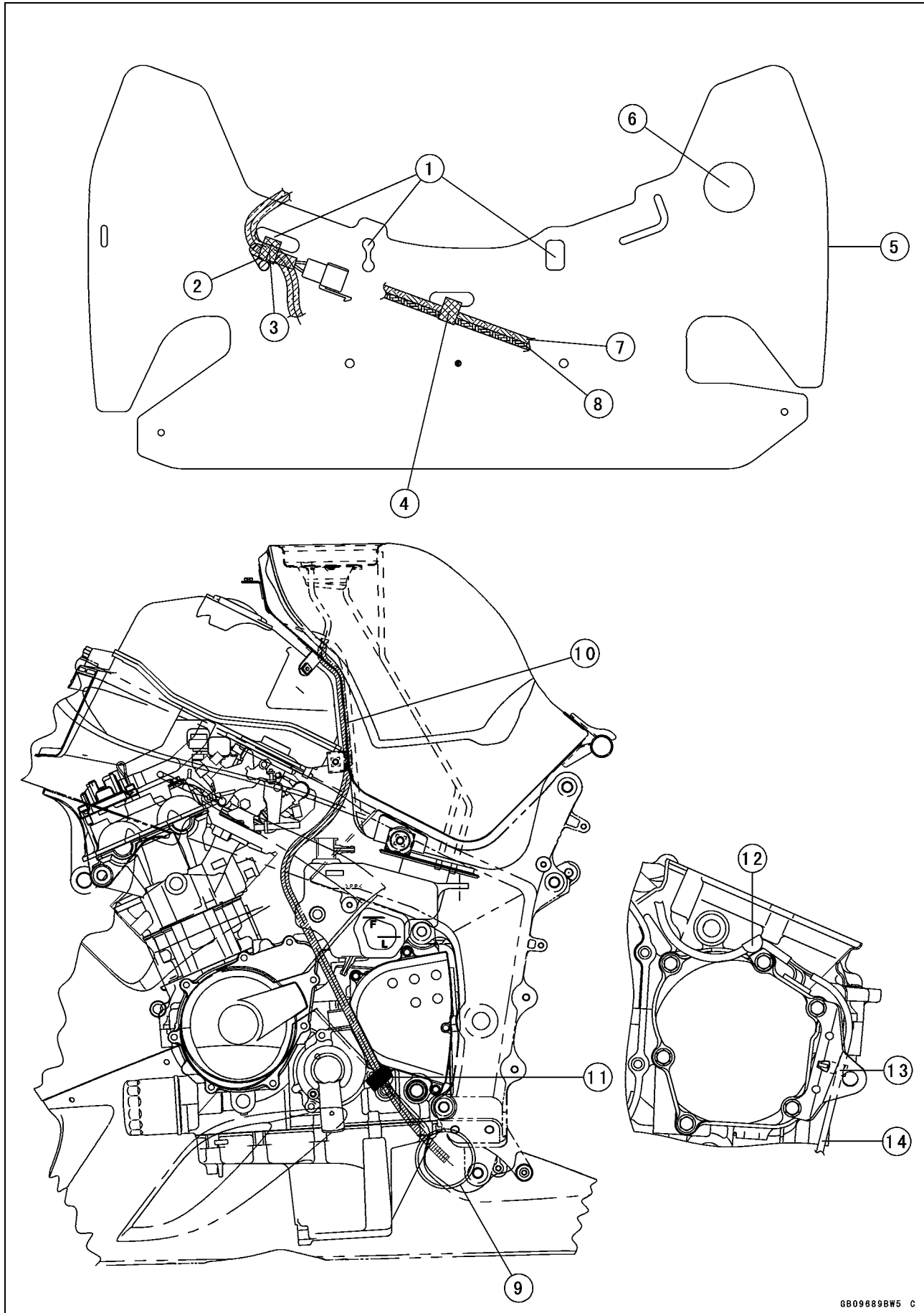

---

**Cable, Wire, and Hose Routing**

---

1. Insert the holes of heat insulation rubber plate in to the radiator stay.
2. Run the fan lead from the holes of heat insulation rubber plate.
3. After install the holes of heat insulation rubber plate, clamp the lead as shown.
4. Clamp the leads so that the heat insulation rubber plate does not fit the radiator.
5. Heat Insulation Rubber Plate
6. Insert the holes of heat insulation rubber plate into the radiator cap.
7. Immobilizer Antenna Lead (Equipped Models)
8. Ignition Switch Lead
9. Position the fuel tank drain hose outside of the lower fairing.
10. Fuel Tank Drain Hose
11. Clamp the regulator/rectifier lead together with the fuel tank drain hose and reserve tank over flow hose.
12. Clamp
13. Clamp
14. To the Oil Pressure Switch

# 17-14 APPENDIX

## Cable, Wire, and Hose Routing

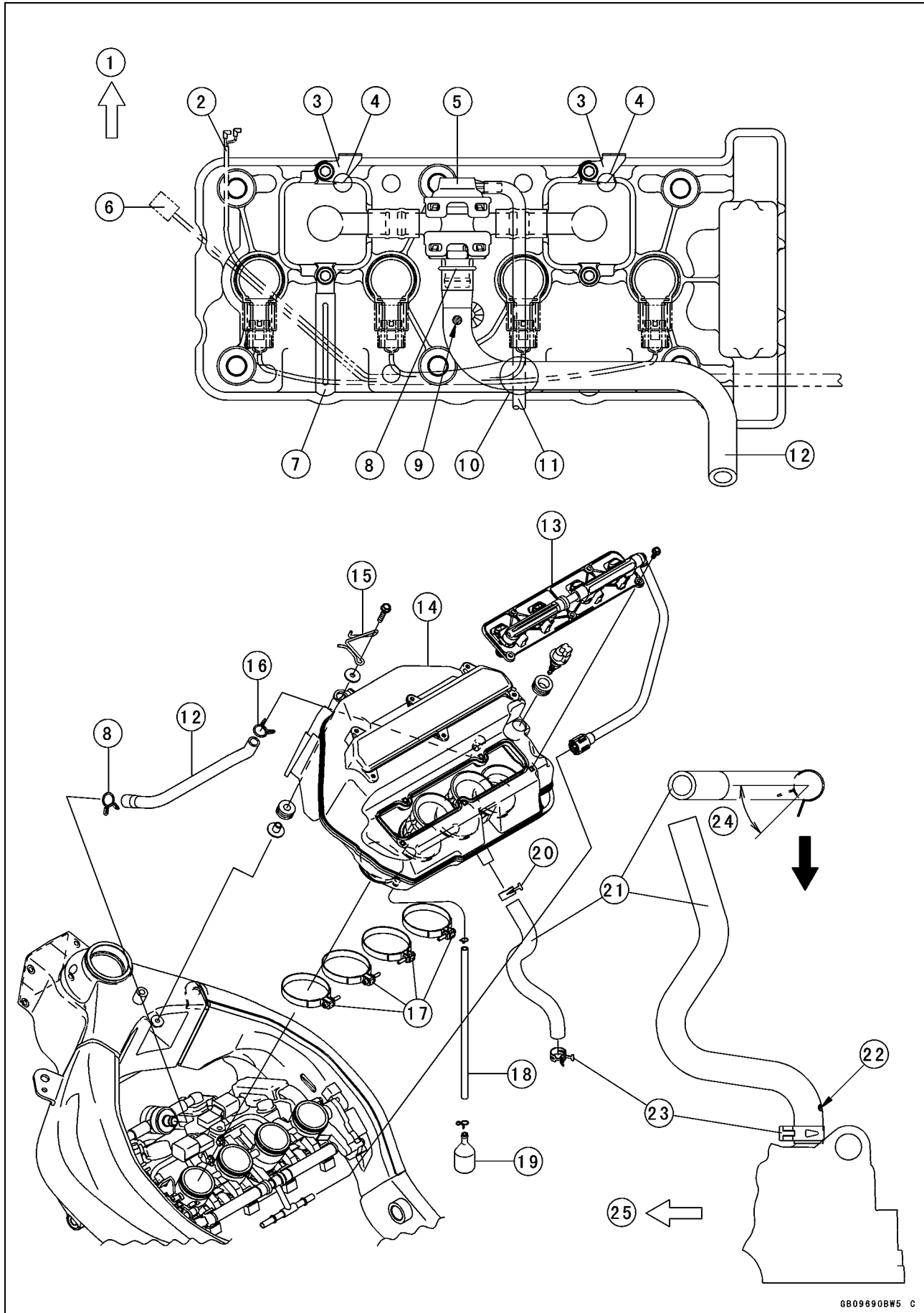

---

**Cable, Wire, and Hose Routing**

---

1. Front
2. Horn Lead
3. Clamps
4. Fit the clamp to the air suction valve cover.
5. Vacuum Switch Valve
6. Radiator Fan Lead
7. Clamp the together with radiator fan lead and horn lead.
8. Position the clamp pinch head facing the cylinder head.
9. Position the paint mark as shown.
10. Run the vacuum switch valve hose over the harnesses.
11. From Throttle Body Assy
12. Vacuum Switch Valve Hose (To the Air Cleaner Housing)
13. Nozzle Assy
14. Air Cleaner Housing
15. Clamp (For Throttle and Clutch Cable)
16. Clamp (Position the clamp pinch head facing right side.)
17. Air Cleaner Housing Holder Clamp
18. Tube
19. Oil Catch Tank
20. Clamp (Position the clamp pinch head facing right side.)
21. Blowby Tube
22. Face the paint mark backward.
23. Clamp
24. 0 ~ 10°
25. Front

# 17-16 APPENDIX

## Cable, Wire, and Hose Routing

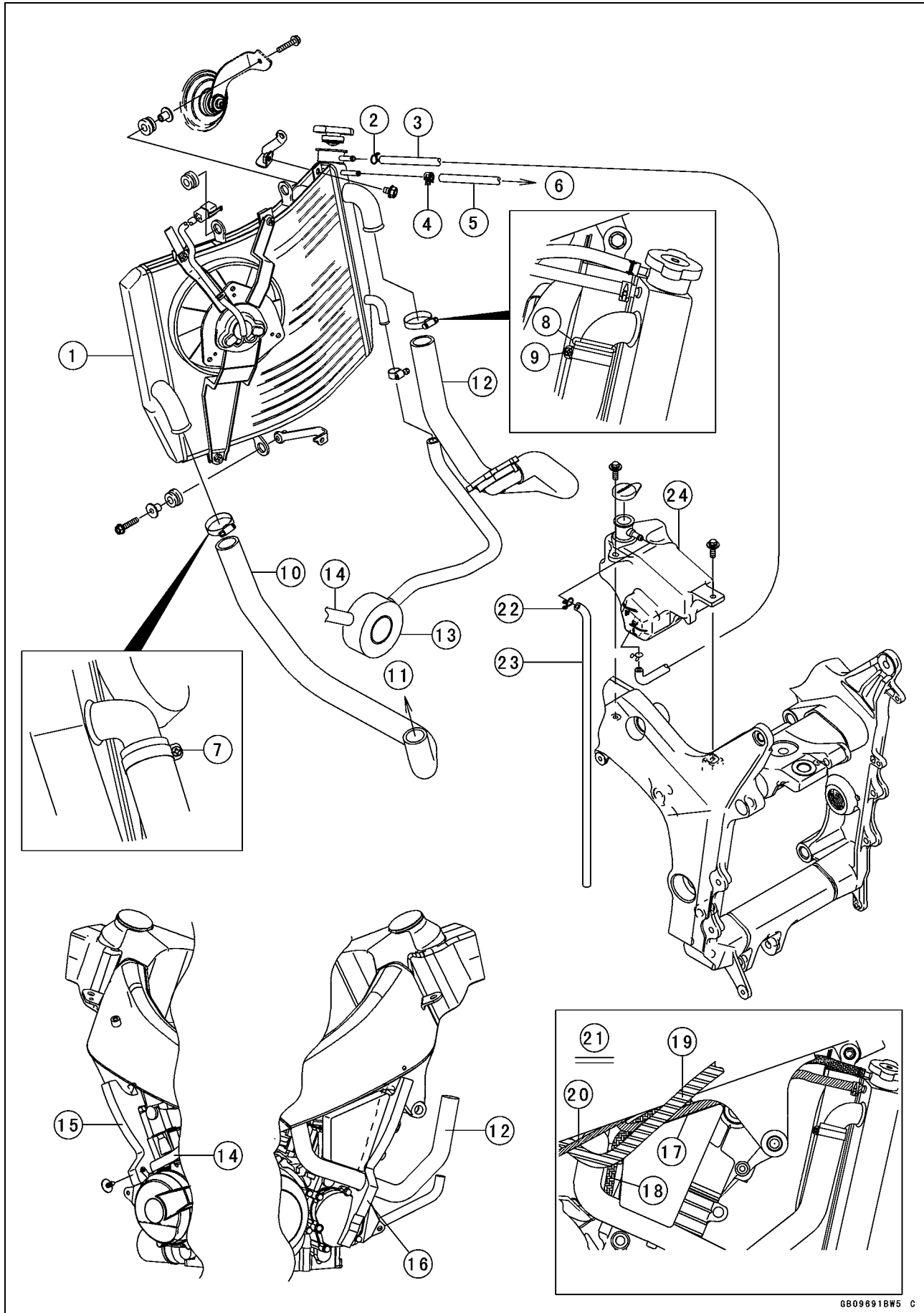

---

**Cable, Wire, and Hose Routing**

---

1. Radiator
2. Clamp
3. Radiator Over Flow Hose
4. Clamp
5. Radiator Coolant Return Hose
6. To the Cylinder Head
7. Install the bolt head of the hose clamp as shown.
8. Insert radiator hose to the corner position of the radiator pipe.
9. Install the bolt head of the hose clamp as shown.
10. Hose
11. To the Water Pump
12. Hose
13. Oil Cooler
14. Hose
15. Left Heat Insulation Damper
16. Right Heat Insulation Damper
17. First run the radiator coolant return hose under the clutch cable. Then run it over the main harness left side, radiator over flow hose and camshaft chain tensioner. Next run it cylinder side more than the other harness.
18. Run the radiator over flow hose under the clutch cable, main harness and radiator coolant return hose.
19. Main Harness
20. Clutch Cable
21. Right Side View
22. Clamp
23. Reserve Tank Drain Hose
24. Coolant Reserve Tank



---

**Cable, Wire, and Hose Routing**

---

1. Hose Clamp
2. Hose Clamp
3. Hose
4. Oil Cooler
5. Oil Filter
6. White Mark
7. Clamp
8. Hose
9. Clamp
10. Radiator Hose
11. Front View
12. Align the paint mark and embossed line.
13. Face the paint mark upward.
14. Install the clamp as shown.
15. Install the clamp as shown.
16. Clamp (California Model only)
17. Hose Clamp
18. Hose Clamp
19. Hose Clamp
20. Align the paint mark and embossed line.
21. Hose Clamp
22. Align the paint mark and embossed line.
23. Neutral Switch Lead
24. Align the paint mark and embossed line.
25. Install the bolt head of the hose clamps direction as shown illustration.

# 17-20 APPENDIX

## Cable, Wire, and Hose Routing

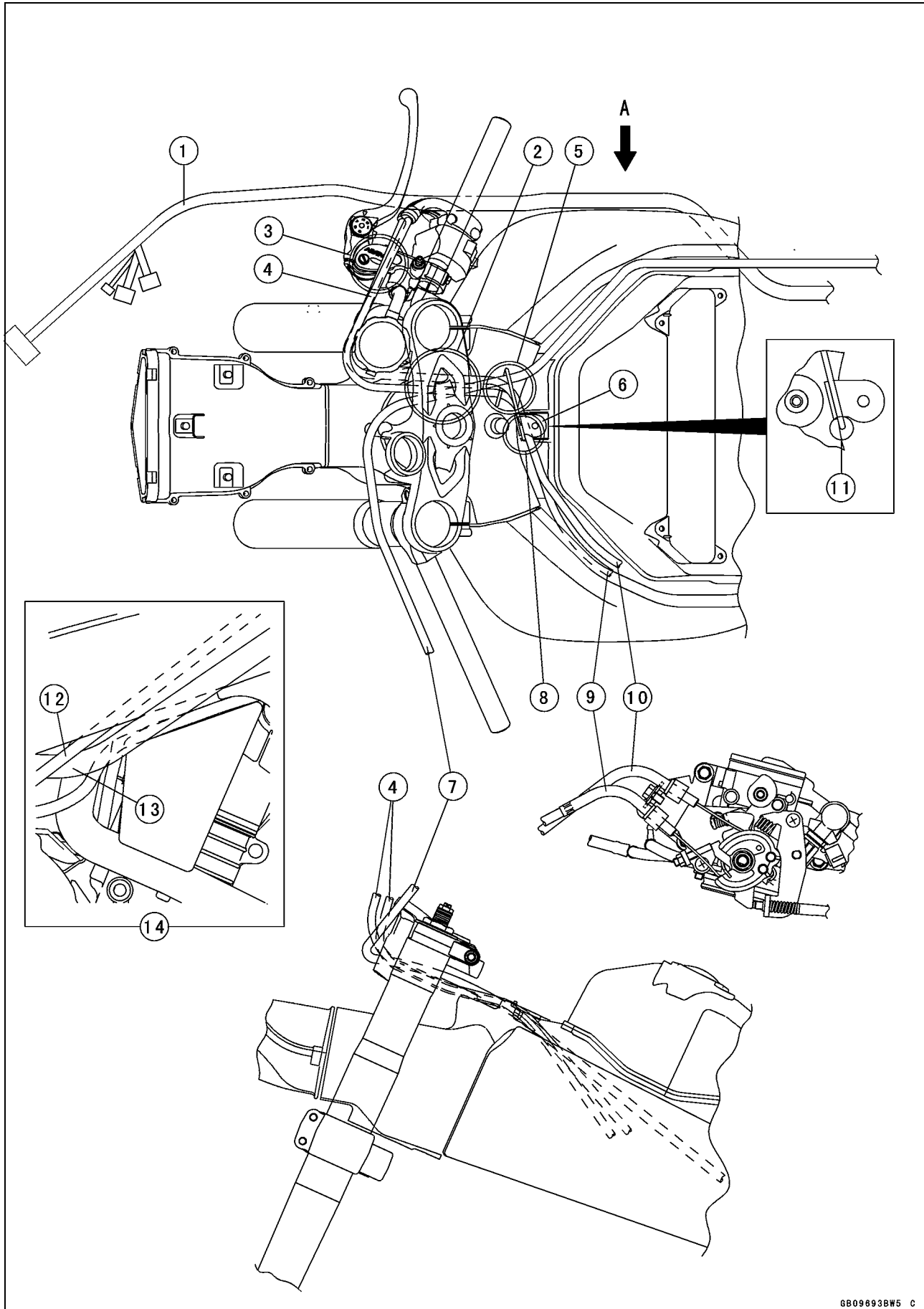

---

**Cable, Wire, and Hose Routing**

---

1. Main Harness
2. Run the clutch cable over the throttle cable.
3. Run the throttle cable over the front master cylinder.
4. Throttle Cables
5. Run the clutch and throttle cable into the clamp.
6. Clamp (Tighten the clamp with air cleaner housing.)
7. Clutch Cable
8. Run the throttle cable under the clamp.
9. Throttle Cable (Accelerator)
10. Throttle Cable (Decelerator)
11. Fit the frame as shown.
12. Run the clutch cable over the main harness.
13. Run the main harness under the clutch cable.
14. Right Side View

# 17-22 APPENDIX

## Cable, Wire, and Hose Routing

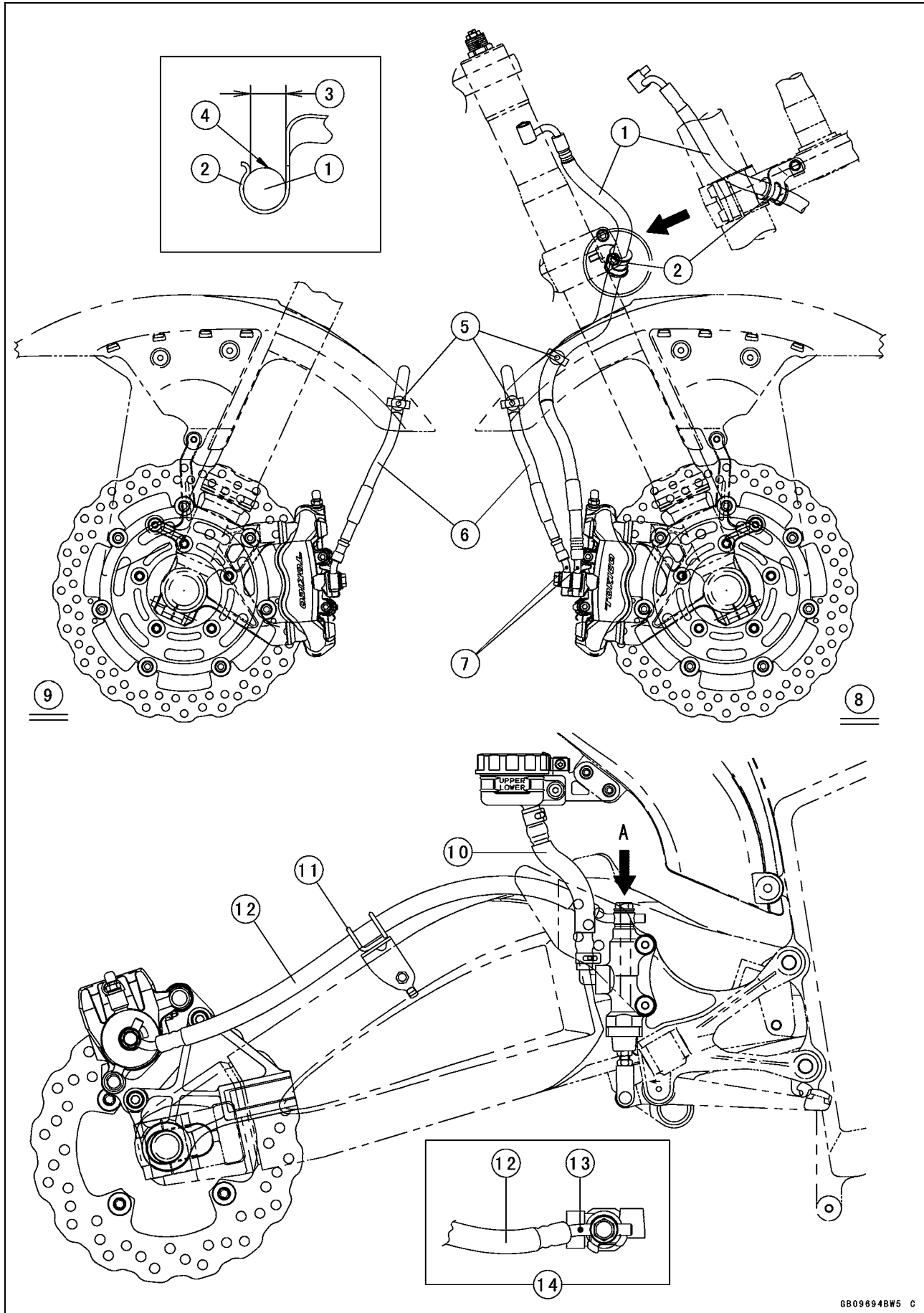

---

**Cable, Wire, and Hose Routing**

---

1. Brake Hose
2. Clamp
3. Install the brake hose so that align the mark with the center of opening of the clamp.
4. Mark
5. Clamps
6. Brake Hose
7. Face the paint mark outside.
8. Right Side View
9. Left Side View
10. Brake Hose
11. Clamp
12. Brake Hose
13. Face the paint mark outside.
14. View A

# 17-24 APPENDIX

## Cable, Wire, and Hose Routing

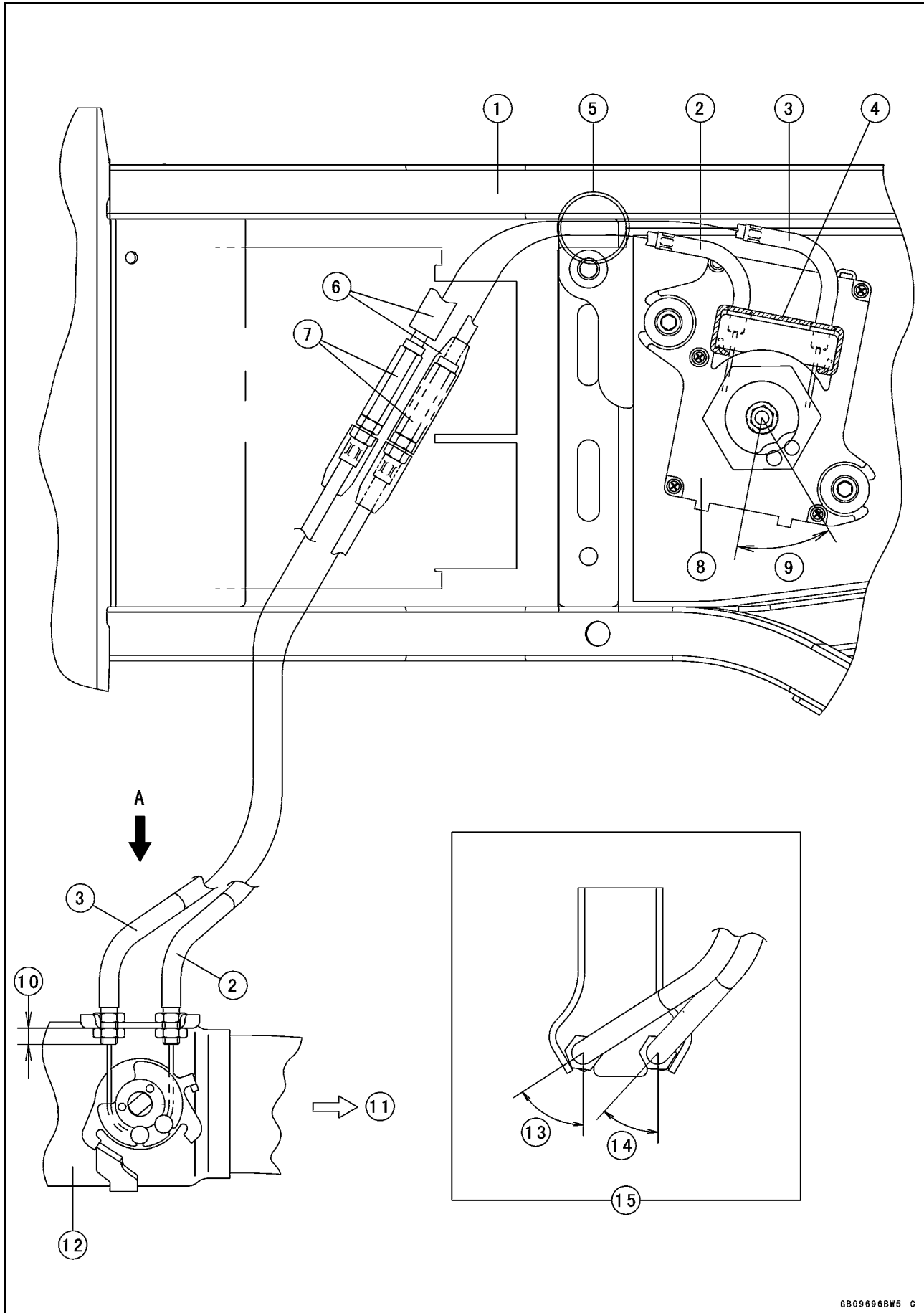

---

**Cable, Wire, and Hose Routing**

---

1. Rear Frame
2. Exhaust Butterfly Valve Cable (Accelerator)
3. Exhaust Butterfly Valve Cable (Decelerator)
4. Holder
5. Position the exhaust butterfly valve cable (accelerator) over the exhaust butterfly valve cable (decelerator).
6. Dust Cover
7. Adjusters
8. Exhaust Butterfly Valve Actuator
9.  $41.7^\circ \pm 7^\circ$  (Original Position of Pulley)
10. 6 mm (0.24 in.)
11. Front
12. Muffler Body
13. Approx.  $57^\circ$
14. Approx.  $42^\circ$
15. View A

# 17-26 APPENDIX

## Cable, Wire, and Hose Routing

### California Model

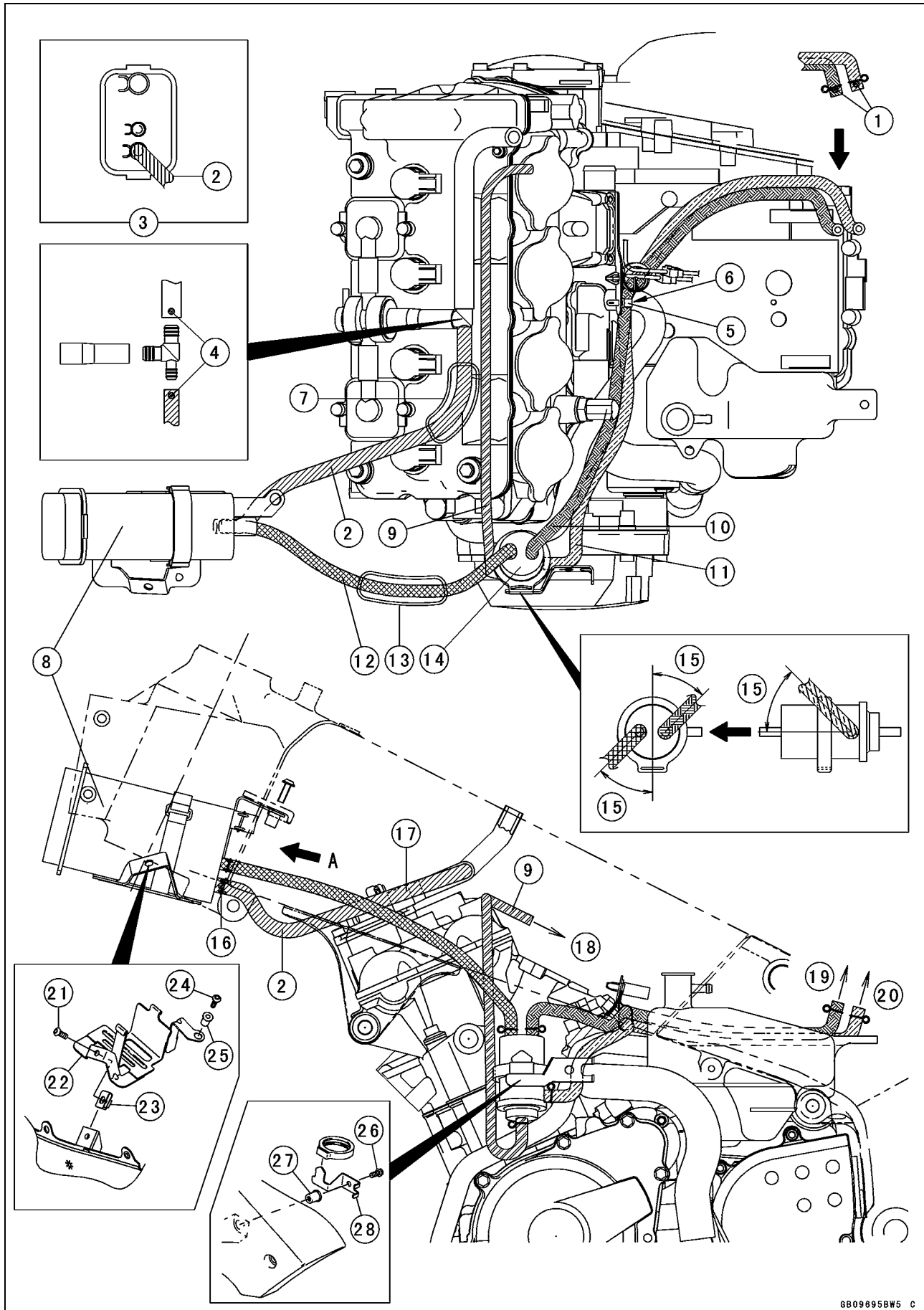

---

**Cable, Wire, and Hose Routing**

---

1. White Marks
2. Hose (Green)
3. View A
4. White Marks
5. Clamp
6. Position the red hose under the blue hose, and clamp the them.
7. Run the green hose over the harness.
8. Canister
9. Hose (White)
10. Hose (Blue)
11. Hose (Red)
12. Hose (Blue)
13. Run the blue hose outside of the frame.
14. Separator
15. Approx. 45°
16. Face the paint mark left side.
17. Run the green hose forward of the engine mount.
18. To the Fitting of the Throttle Body #4
19. To the Fuel Tank (Blue Hose)
20. To the Fuel Tank (Red Hose)
21. Bolt
22. Install the nut to the center fairing.
23. Canister Bracket
24. Bolt
25. Install the nut to the frame.
26. Bolt
27. Install the nut to the center fairing.
28. Separator Bracket

## 17-28 APPENDIX

### Troubleshooting Guide

---

#### NOTE

- Refer to the *Fuel System* chapter for most of DFI trouble shooting guide.
- This is not an exhaustive list, giving every possible cause for each problem listed. It is meant simply as a rough guide to assist the troubleshooting for some of the more common difficulties.

#### Engine Doesn't Start, Starting Difficulty:

##### Starter motor not rotating:

- Starter lockout switch or neutral switch trouble
- Starter motor trouble
- Battery voltage low
- Starter relay not contacting or operating
- Starter button not contacting
- Wiring open or shorted
- Ignition switch trouble
- Engine stop switch trouble
- Fuse blown

##### Starter motor rotating but engine doesn't turn over:

- Immobilizer system trouble
- Starter clutch trouble
- Vehicle-down sensor (DFI) coming off

##### Engine won't turn over:

- Valve seizure
- Valve lifter seizure
- Cylinder, piston seizure
- Crankshaft seizure
- Connecting rod small end seizure
- Connecting rod big end seizure
- Transmission gear or bearing seizure
- Camshaft seizure
- Starter idle gear seizure

##### No fuel flow:

- No fuel in tank
- Fuel pump trouble
- Fuel tank air vent obstructed
- Fuel filter clogged
- Fuel line clogged

##### No spark; spark weak:

- Vehicle-down sensor (DFI) coming off
- Ignition switch not ON
- Engine stop switch turned OFF
- Clutch lever not pulled in or gear not in neutral
- Battery voltage low
- Immobilizer system trouble
- Spark plug dirty, broken, or gap maladjusted
- Stick coil shorted or not in good contact
- Stick coil trouble
- Spark plug incorrect
- IC igniter in ECU trouble

- Camshaft position sensor trouble
- Neutral, starter lockout, or side stand switch trouble
- Crankshaft sensor trouble
- Ignition switch or engine stop switch shorted
- Wiring shorted or open
- Fuse blown

##### Fuel/air mixture incorrect:

- Bypass screw and/or idle adjusting screw maladjusted
- Air passage clogged
- Air cleaner clogged, poorly sealed, or missing

##### Compression Low:

- Spark plug loose
- Cylinder head not sufficiently tightened down
- No valve clearance
- Cylinder, piston worn
- Piston ring bad (worn, weak, broken, or sticking)
- Piston ring/groove clearance excessive
- Cylinder head gasket damaged
- Cylinder head warped
- Valve spring broken or weak
- Valve not seating properly (valve bent, worn, or carbon accumulation on the seating surface)

#### Poor Running at Low Speed:

##### Spark weak:

- Battery voltage low
- Spark plug dirty, broken, or maladjusted
- Stick coil wiring trouble
- Stick coil not in good contact
- Spark plug incorrect
- IC igniter in ECU trouble
- Camshaft position sensor trouble
- Crankshaft sensor trouble
- Stick coil trouble
- Immobilizer system trouble

##### Fuel/air mixture incorrect:

- Bypass screw maladjusted
- Air passage clogged
- Air bleed pipe bleed holes clogged
- Pilot passage clogged
- Air cleaner clogged, poorly sealed, or missing
- Fuel tank air vent obstructed
- Fuel pump trouble
- Throttle body assy holder loose
- Air cleaner duct loose

##### Compression low:

- Spark plug loose
- Cylinder head not sufficiently tightened down

## Troubleshooting Guide

No valve clearance  
 Cylinder, piston worn  
 Piston ring bad (worn, weak, broken, or sticking)  
 Piston ring/groove clearance excessive  
 Cylinder head warped  
 Cylinder head gasket damaged  
 Valve spring broken or weak  
 Valve not seating properly (valve bent, worn, or carbon accumulation on the seating surface)

### Other:

IC igniter in ECU trouble  
 Throttle body assy not synchronizing  
 Engine oil viscosity too high  
 Drive train trouble  
 Brake dragging  
 Air suction valve trouble  
 Vacuum switch valve trouble  
 Engine overheating  
 Clutch slipping

## Poor Running or No Power at High Speed:

### Firing incorrect:

Spark plug dirty, broken, or maladjusted  
 Stick coil wiring trouble  
 Stick coil not in good contact  
 Spark plug incorrect  
 Camshaft position sensor trouble  
 IC igniter in ECU trouble  
 Crankshaft sensor trouble  
 Stick coil trouble

### Fuel/air mixture incorrect:

Air cleaner clogged, poorly sealed, or missing  
 Air cleaner O-ring damaged  
 Air cleaner duct loose  
 Water or foreign matter in fuel  
 Throttle body assy holder loose  
 Fuel to injector insufficient  
 Fuel tank air vent obstructed  
 Fuel line clogged  
 Fuel pump trouble

### Compression low:

Spark plug loose  
 Cylinder head not sufficiently tightened down  
 No valve clearance  
 Cylinder, piston worn  
 Piston ring bad (worn, weak, broken, or sticking)  
 Piston ring/groove clearance excessive  
 Cylinder head gasket damaged  
 Cylinder head warped  
 Valve spring broken or weak

Valve not seating properly (valve bent, worn, or carbon accumulation on the seating surface.)

### Knocking:

Carbon built up in combustion chamber  
 Fuel poor quality or incorrect  
 Spark plug incorrect  
 IC igniter in ECU trouble  
 Camshaft position sensor trouble  
 Crankshaft sensor trouble

### Miscellaneous:

Throttle valve won't fully open  
 Brake dragging  
 Clutch slipping  
 Engine overheating  
 Engine oil level too high  
 Engine oil viscosity too high  
 Drive train trouble  
 Air suction valve trouble  
 Vacuum switch valve trouble  
 Catalytic converter melt down due to muffler overheating (KLEEN)

## Overheating:

### Firing incorrect:

Spark plug dirty, broken, or maladjusted  
 Spark plug incorrect  
 IC igniter in ECU trouble

### Muffler overheating:

For KLEEN, do not run the engine even if with only one cylinder misfiring or poor running (Request the nearest service facility to correct it)  
 For KLEEN, do not push-start with a dead battery (Connect another full-charged battery with jumper cables, and start the engine using the electric starter)  
 For KLEEN, do not start the engine under misfire due to spark plug fouling or poor connection of the stick coil  
 For KLEEN, do not coast the motorcycle with the ignition switch off (Turn the ignition switch ON and run the engine)  
 IC igniter in ECU trouble

### Fuel/air mixture incorrect:

Throttle body assy holder loose  
 Air cleaner duct loose  
 Air cleaner poorly sealed, or missing  
 Air cleaner O-ring damaged  
 Air cleaner clogged

### Compression high:

Carbon built up in combustion chamber

### Engine load faulty:

Clutch slipping  
 Engine oil level too high  
 Engine oil viscosity too high  
 Drive train trouble

## 17-30 APPENDIX

### Troubleshooting Guide

---

Brake dragging

**Lubrication inadequate:**

- Engine oil level too low
- Engine oil poor quality or incorrect

**Oil cooler incorrect:**

- Oil cooler clogged

**Gauge incorrect:**

- Water temperature gauge broken
- Water temperature sensor broken

**Coolant incorrect:**

- Coolant level too low
- Coolant deteriorated
- Wrong coolant mixed ratio

**Cooling system component incorrect:**

- Radiator fin damaged
- Radiator clogged
- Thermostat trouble
- Radiator cap trouble
- Radiator fan switch trouble
- Radiator fan relay trouble
- Fan motor broken
- Fan blade damaged
- Water pump not turning
- Water pump impeller damaged

**Over Cooling:**

**Gauge incorrect:**

- Water temperature gauge broken
- Water temperature sensor broken

**Cooling system component incorrect:**

- Radiator fan switch trouble
- Thermostat trouble

**Clutch Operation Faulty:**

**Clutch slipping:**

- Friction plate worn or warped
- Steel plate worn or warped
- Clutch spring broken or weak
- Clutch hub or housing unevenly worn
- No clutch lever play
- Clutch inner cable trouble
- Clutch release mechanism trouble

**Clutch not disengaging properly:**

- Clutch plate warped or too rough
- Clutch spring compression uneven
- Engine oil deteriorated
- Engine oil viscosity too high
- Engine oil level too high
- Clutch housing frozen on drive shaft
- Clutch hub nut loose
- Clutch hub spline damaged
- Clutch friction plate installed wrong
- Clutch lever play excessive
- Clutch release mechanism trouble

**Gear Shifting Faulty:**

**Doesn't go into gear; shift pedal doesn't return:**

- Clutch not disengaging
- Shift fork bent or seized
- Gear stuck on the shaft
- Gear positioning lever binding
- Shift return spring weak or broken
- Shift return spring pin loose
- Shift mechanism arm spring broken
- Shift mechanism arm broken
- Shift pawl broken

**Jumps out of gear:**

- Shift fork ear worn, bent
- Gear groove worn
- Gear dogs and/or dog holes worn
- Shift drum groove worn
- Gear positioning lever spring weak or broken
- Shift fork guide pin worn
- Drive shaft, output shaft, and/or gear splines worn

**Overshifts:**

- Gear positioning lever spring weak or broken
- Shift mechanism arm spring broken

**Abnormal Engine Noise:**

**Knocking:**

- IC igniter in ECU trouble
- Carbon built up in combustion chamber
- Fuel poor quality or incorrect
- Spark plug incorrect
- Overheating

**Piston slap:**

- Cylinder/piston clearance excessive
- Cylinder, piston worn
- Connecting rod bent
- Piston pin, piston pin hole worn

**Valve noise:**

- Valve clearance incorrect
- Valve spring broken or weak
- Camshaft bearing worn
- Valve lifter worn

**Other noise:**

- Connecting rod small end clearance excessive
- Connecting rod big end clearance excessive
- Piston ring/groove clearance excessive
- Piston ring worn, broken, or stuck
- Piston ring groove worn
- Piston seizure, damage
- Cylinder head gasket leaking
- Exhaust pipe leaking at cylinder head connection
- Crankshaft runout excessive

## Troubleshooting Guide

Engine mount loose  
 Crankshaft bearing worn  
 Primary gear worn or chipped  
 Camshaft chain tensioner trouble  
 Camshaft chain, sprocket, guide worn  
 Air suction valve damaged  
 Vacuum switch valve damaged  
 Alternator rotor loose  
 Catalytic converter melt down due to muffler overheating (KLEEN)

### Abnormal Drive Train Noise:

#### Clutch noise:

Clutch damper weak or damaged  
 Clutch housing/friction plate clearance excessive  
 Clutch housing gear worn  
 Wrong installation of outside friction plate

#### Transmission noise:

Bearings worn  
 Transmission gear worn or chipped  
 Metal chips jammed in gear teeth  
 Engine oil insufficient

#### Drive line noise:

Drive chain adjusted improperly  
 Drive chain worn  
 Rear and/or engine sprocket worn  
 Chain lubrication insufficient  
 Rear wheel misaligned

### Abnormal Frame Noise:

#### Front fork noise:

Oil insufficient or too thin  
 Spring weak or broken

#### Rear shock absorber noise:

Shock absorber damaged

#### Disc brake noise:

Pad installed incorrectly  
 Pad surface glazed  
 Disc warped  
 Caliper trouble

#### Other noise:

Bracket, nut, bolt, etc. not properly mounted or tightened

### Oil Pressure Warning Light Goes On:

Engine oil pump damaged  
 Engine oil screen clogged  
 Engine oil filter clogged  
 Engine oil level too low  
 Engine oil viscosity too low  
 Camshaft bearing worn  
 Crankshaft bearing worn  
 Oil pressure switch damaged  
 Wiring faulty  
 Relief valve stuck open

O-ring at the oil passage in the crankcase damaged

### Exhaust Smokes Excessively:

#### White smoke:

Piston oil ring worn  
 Cylinder worn  
 Valve oil seal damaged  
 Valve guide worn  
 Engine oil level too high

#### Black smoke:

Air cleaner clogged

#### Brown smoke:

Air cleaner duct loose  
 Air cleaner O-ring damaged  
 Air cleaner poorly sealed or missing

### Handling and/or Stability Unsatisfactory:

#### Handlebar hard to turn:

Cable routing incorrect  
 Hose routing incorrect  
 Wiring routing incorrect  
 Steering stem nut too tight  
 Steering stem bearing damaged  
 Steering stem bearing lubrication inadequate  
 Steering stem bent  
 Tire air pressure too low

#### Handlebar shakes or excessively vibrates:

Tire worn  
 Swingarm pivot bearing worn  
 Rim warped, or not balanced  
 Wheel bearing worn  
 Handlebar bolt loose  
 Steering stem nut loose  
 Front, rear axle runout excessive  
 Engine mounting bolt loose

#### Handlebar pulls to one side:

Frame bent  
 Wheel misalignment  
 Swingarm bent or twisted  
 Swingarm pivot shaft runout excessive  
 Steering maladjusted  
 Front fork bent  
 Right and left front fork oil level uneven

#### Shock absorption unsatisfactory:

(Too hard)  
 Front fork oil excessive  
 Front fork oil viscosity too high  
 Rear shock absorber adjustment too hard  
 Tire air pressure too high  
 Front fork bent  
 (Too soft)  
 Tire air pressure too low  
 Front fork oil insufficient and/or leaking  
 Front fork oil viscosity too low

## 17-32 APPENDIX

---

### Troubleshooting Guide

---

- Rear shock adjustment too soft
- Front fork, rear shock absorber spring weak
- Rear shock absorber oil leaking

#### **Brake Doesn't Hold:**

- Air in the brake line
- Pad or disc worn
- Brake fluid leakage
- Disc warped
- Contaminated pad
- Brake fluid deteriorated
- Primary or secondary cup damaged in master cylinder
- Master cylinder scratched inside

#### **Battery Trouble:**

##### **Battery discharged:**

- Charge insufficient
- Battery faulty (too low terminal voltage)
- Battery cable making poor contact
- Load excessive (e.g., bulb of excessive wattage)
- Ignition switch trouble
- Alternator trouble
- Wiring faulty
- Regulator/rectifier trouble

##### **Battery overcharged:**

- Alternator trouble
- Regulator/rectifier trouble
- Battery faulty

### MODEL APPLICATION

Year	Model	Beginning Frame No.
2005	ZX636-C1	JKBZXJC1□5A000001 JKBZX636CCA000001 ZX636C-000001

□:This digit in the frame number changes from one machine to another.



KAWASAKI HEAVY INDUSTRIES, LTD.  
Consumer Products & Machinery Company

Part No.99924-1345-02

Printed in Japan