

# Canon

## Digital Video Camcorder Instruction Manual



Introduction

Mastering  
the Basics

Using the Full  
Range of Features

Editing

Using a Memory Card

Additional  
Information

# MV6i MC

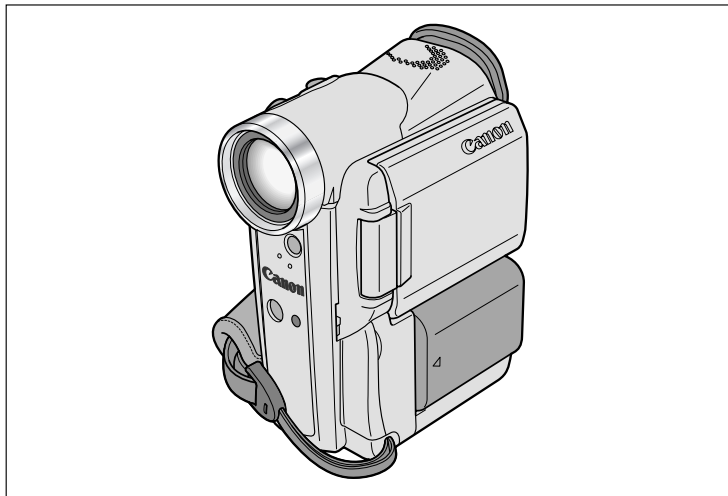

Mini **DV** Digital  
Video  
Cassette

 **BUBBLE JET  
DIRECT**

**PAL**

# Important Usage Instructions

**E**

Introduction

**WARNING:**



**TO REDUCE THE RISK OF ELECTRIC SHOCK, DO NOT REMOVE COVER (OR BACK). NO USER SERVICEABLE PARTS INSIDE. REFER SERVICING TO QUALIFIED SERVICE PERSONNEL.**

**WARNING:**



**TO REDUCE THE RISK OF FIRE OR ELECTRIC SHOCK, DO NOT EXPOSE THIS PRODUCT TO RAIN OR MOISTURE.**

**CAUTION:**

**TO REDUCE THE RISK OF ELECTRIC SHOCK AND TO REDUCE ANNOYING INTERFERENCE, USE THE RECOMMENDED ACCESSORIES ONLY.**

**CAUTION:**

**DISCONNECT THE MAINS PLUG FROM THE SUPPLY SOCKET WHEN NOT IN USE.**

CA-PS700 identification plate is located on the bottom.

- Use of CV-150F/CV-250F DV cable is necessary to comply with the technical requirement of EMC Directive.

## Reference Guide

The following manuals are supplied with the camcorder:

### ■ **Digital Video Camcorder MV6i MC Instruction Manual**

This manual explains the camcorder operations from basic video recording to the use of the full range of features.

### ■ **DIGITAL VIDEO SOLUTION DISK Software Instruction Manual**



This manual explains how to download images from the memory card to a computer using the supplied USB cable. You can add sample images for Card Mix from the supplied DIGITAL VIDEO SOLUTION DISK.

### ■ **Windows XP Users Only**

#### **DV NETWORK SOLUTION DISK Software Instruction Manual**

This manual explains how to download/upload images from/to the memory card using a DV (IEEE1394) cable. You can also perform videoconference and file transfer over the Internet using the provided software. Available functions depend upon the camcorder model of your contact and networking environment.

### **Trademark Acknowledgements**

- Canon is a registered trademark of Canon Inc.
- Mini  is a trademark.
-  logo is a trademark.
- Windows® is either a registered trademark or trademark of Microsoft Corporation in the United States and/or other countries.
- Other names and products not mentioned above may be registered trademarks or trademarks of their respective companies.

# Contents

**Introduction**

|                                      |   |
|--------------------------------------|---|
| Important Usage Instructions .....   | 2 |
| Reference Guide .....                | 3 |
| Thank you for Choosing a Canon ..... | 7 |
| Introducing the MV6i MC .....        | 8 |

**Mastering the Basics**

|                                       |   |
|---------------------------------------|---|
| Finding Your Way Around the MV6i MC.. | 9 |
|---------------------------------------|---|

**Preparations**

|                               |    |
|-------------------------------|----|
| Powering Your Camcorder ..... | 12 |
| Loading a Cassette .....      | 16 |

**Basic Recording**

|                                    |    |
|------------------------------------|----|
| Recording Movies onto a Tape ..... | 18 |
| Zooming .....                      | 23 |
| Using the LCD Screen .....         | 25 |

**Basic Playback**

|   |    |
|---|----|
| Playing Back a Tape .....                       | 28 |
| Connections for Playback<br>on a TV Screen..... | 32 |
| Tips for Making Better Videos .....             | 36 |

**Using the Full Range of Features****General**

|  |    |
|--|----|
| Searching and Reviewing<br>While Recording ..... | 38 |
| Using the Menus .....                            | 39 |
| Using the Wireless Controller .....              | 48 |

**For Recording**

|  |    |
|--|----|
| Setting the Date and Time.....           | 51 |
| Recording Still Images onto a Tape ..... | 54 |
| Turning the Image Stabilizer Off .....   | 56 |
| Using the Various Recording Programs ..  | 57 |
| Using Digital Effects.....               | 61 |
| Using the Multi-Image Screen .....       | 67 |
| Audio Recording .....                    | 69 |
| Setting the Self-Timer .....             | 71 |

**When Making Manual Adjustments**

|                                 |    |
|---------------------------------|----|
| Adjusting AE Shift .....        | 73 |
| Setting the Shutter Speed ..... | 74 |
| Adjusting Focus Manually .....  | 76 |
| Setting the White Balance.....  | 77 |

**For Playback**

|  |    |
|--|----|
| Enlarging the Image during Playback .....                    | 79 |
| Displaying Date, Time and<br>Camcorder Data (Data Code)..... | 80 |
| Searching the Tape<br>(Photo Search/Date Search) .....       | 83 |
| Returning to a Pre-Marked Position .....                     | 84 |

**Editing**

|  |     |
|--|-----|
| Editing to a VCR.....  | 85  |
| Dubbing to/from a Tape<br>with Digital Video Equipment .....                               | 86  |
| Recording from a VCR, TV or Analog<br>Camcorder (Analog Line-in) .....                     | 89  |
| Digitally Outputting Analog Video<br>and Audio Signals<br>(Analog-Digital Converter) ..... | 91  |
| Recording Over Existing Scenes<br>(AV Insert Editing).....                                 | 93  |
| Audio Dubbing .....  | 96  |
| Setting the Audio Mix .....  | 99  |
| Connecting to a Computer Using a DV<br>(IEEE1394) Cable .....                              | 101 |

## Using a Memory Card

|   |     |
|---|-----|
| Inserting and Removing the<br>Memory Card .....                       | 102 |
| Selecting the Image Quality/Size .....                                | 103 |
| Recording Still Images on<br>a Memory Card .....                      | 107 |
| Recording Motion JPEG Movies<br>on a Memory Card .....                | 112 |
| Recording Panoramic Images<br>(Stitch Assist) .....                   | 115 |
| Playing Back a Memory Card .....                                      | 117 |
| Settings of Still Images/Movies .....                                 | 120 |
| Preventing Accidental Erasure (Protect)                               | 123 |
| Marking a Still Image for Printing<br>(Print Mark) .....              | 124 |
| Erasing Still Images/Movies .....                                     | 126 |
| Printing with the Direct Print Function..                             | 128 |
| Combining Images and Recording<br>Them to a Cassette (Card Mix) ..... | 135 |
| Copying Still Images<br>from Tape to Memory Card .....                | 138 |
| Copying Still Images<br>from Memory Card to Tape .....                | 139 |
| Formatting a Memory Card.....   | 140 |
| Connecting to a Computer Using a<br>USB Cable .....                   | 141 |
| Other Information and Precautions .....                               | 142 |

## Additional Information

|                                   |     |
|-----------------------------------|-----|
| Preparing the Camcorder.....      | 145 |
| Notes on Using the Batteries..... | 146 |
| Maintenance .....                 | 149 |
| Troubleshooting.....              | 153 |
| The MV6i MC System Diagram.....   | 157 |
| Optional Accessories .....        | 158 |
| Screen Displays .....             | 160 |
| Specifications .....              | 167 |
| Index .....                       | 169 |



## Symbols used in this instruction manual

 : Reference page numbers

 : Functions that can be operated from the body of the camcorder

 : Functions that can be operated from the wireless controller

 : Supplementary notes for camcorder operation

 : Operation confirmation beeps (  22)

- Capital letters are used to refer to settings displayed in the menus and buttons labelled on the camcorder itself, e.g. Press the MENU button.

## Switch Positions by Operating Modes

| Operating Mode  | POWER switch | TAPE/CARD switch |
|-----------------|--------------|------------------|
| CAMERA          | CAMERA       | TAPE             |
| PLAY (VCR)      | PLAY (VCR)   | TAPE             |
| CARD CAMERA     | CAMERA       | CARD             |
| CARD PLAY (VCR) | PLAY (VCR)   | CARD             |

\* Available functions vary depending on the operating mode. It is indicated as follows:

**CAMERA** : Function can be used in this mode.

CAMERA : Function cannot be used in this mode.

# Thank you for Choosing a Canon

First, we'd like to thank you for purchasing this Canon camcorder. Its advanced technology makes it very easy to use — you will soon be making high-quality videos which will give you pleasure for years to come.







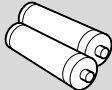
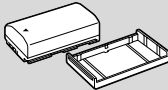
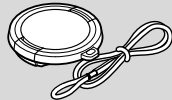

To get the most out of your new camcorder, we recommend that you read this manual thoroughly — there are many sophisticated features which will add to your recording enjoyment.

## Getting started

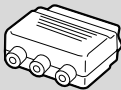
To get started we suggest that you master the basic operations of the camcorder first, before moving on to use its full range of features.

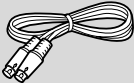
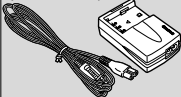
- When connecting the camcorder to your personal computer, use the optional CV-150F or CV-250F DV cable.
- When connecting the camcorder to your PC equipped with a USB terminal, use the supplied IFC-300PCU USB cable.

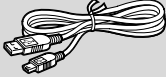
Your camcorder is supplied with the following accessories:

|  |  |
|--|--|
| WL-D77 Wireless Controller<br>          | Two AA batteries<br>  |
| NB-2L Battery Pack<br>                  | Lens cap and lens cap cord<br>                                |
| Lithium button battery CR1616<br>       | CA-PS700 Compact Power Adapter (including AC power cable)<br> |
| PC-A10 SCART Adapter (Europe, Asia)<br> | STV-250N Stereo Video Cable<br>                               |
| S-150 S-video Cable<br>                | CB-2LTE Battery Charger (including AC power cable)<br>       |
| Hard Case for SD Memory Card<br>      | SDC-8M SD Memory Card (with pre-recorded sample images)<br> |
| IFC-300PCU USB Cable<br>              | DIGITAL VIDEO SOLUTION DISK, DV NETWORK SOLUTION DISK<br>   |

# Introducing the MV6i MC

E

Introduction

## 10× Optical and 400× Digital Zoom

This zoom range will more than take care of all your picture-taking needs, from wide-angle shots to close-ups at full telephoto (7.5× optical zoom and 30× digital zoom when using a memory card).

## Image Stabilizer

Stabilises your recordings even in long telephoto shots (in CAMERA mode).

## Night Mode

Allows recording even in dark places. The Night mode adjusts automatically to the optimum shutter speed (in CAMERA mode).

## Super Night Mode and Low Light Plus Mode

With the Super Night mode (in CAMERA mode) and Low Light Plus mode (in CARD CAMERA mode), you can keep on shooting without turning the lights on. The assist lamp (White LED) lights up to illuminate the subject.

## Still Images

Just press the photo button to capture still images like photographs.

## Analog Line-in Recording/ AV Insert Editing/ Audio Dubbing

## Digital Effects

Show your creativity by using the special effects and faders. The multi-image screen captures moving subjects in 4, 9 or 16 sequences of still images.

## Memory Card

You can record images on a SD Memory Card or MultiMediaCard. Images recorded in Stitch Assist mode can be merged into one panoramic scene with the supplied software.

## Direct Print

You can print still images by connecting to a Canon Printer with Direct Print Function. Refer to p. 128 for printers that can be used with your camcorder.

## USB Terminal

Allows transfer of memory card data to a computer with built-in USB port. You can organise and edit images on your computer using the supplied software.

## IEEE 1394 DV Terminal

The DV terminal allows high-quality transfer with virtually no deterioration in quality of images. You can edit images by connecting the camcorder to a PC with IEEE1394 terminal. Windows XP Users can use the supplied software to perform videoconference and file transfer over the Internet\*.

\* Windows Messenger 4.5 or higher required.

# Finding Your Way Around the MV6i MC

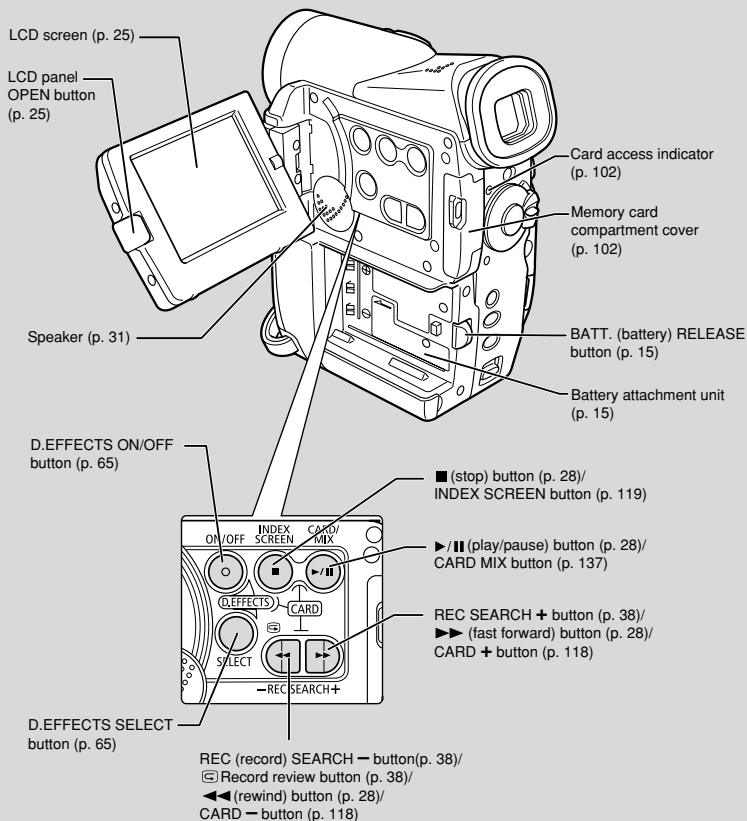

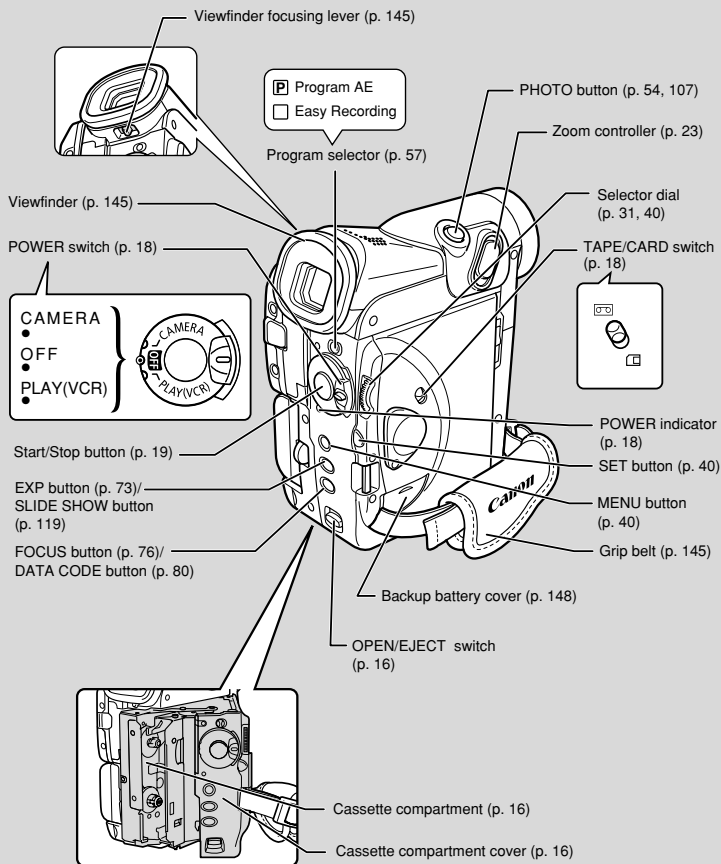

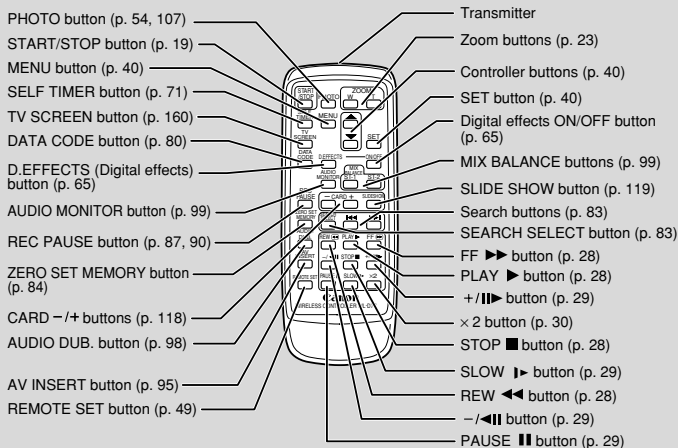
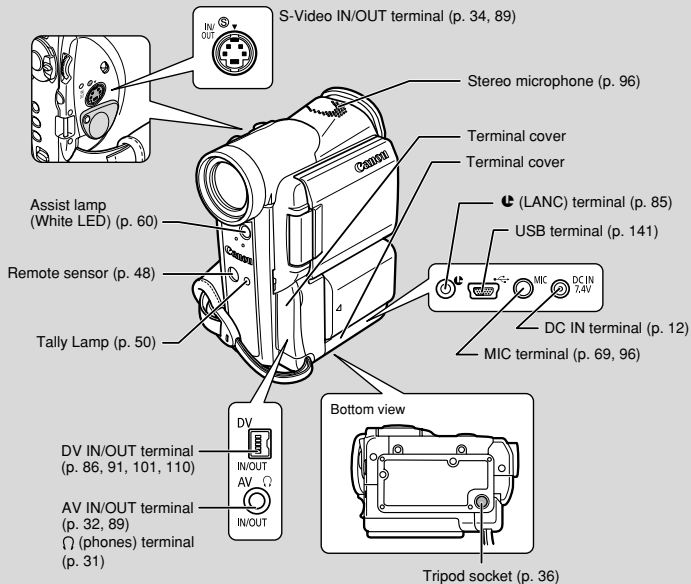

## Powering Your Camcorder

Before operating your camcorder, you will need to use the power adapter to:

**Provide power from a household power socket**

or

**Charge a battery pack**

### **Notes:**

- The power adapter converts current from a household power socket (100–240 V AC, 50/60 Hz) to the DC current used by your camcorder.
- If the adapter is used next to a TV, it may cause bars to appear on the TV — move the adapter away from the TV or the aerial cable.
- Do not connect an unspecified product to the camcorder's DC terminal. Likewise, do not connect the power adapter to an unspecified product.

### Connecting the camcorder to a household power socket

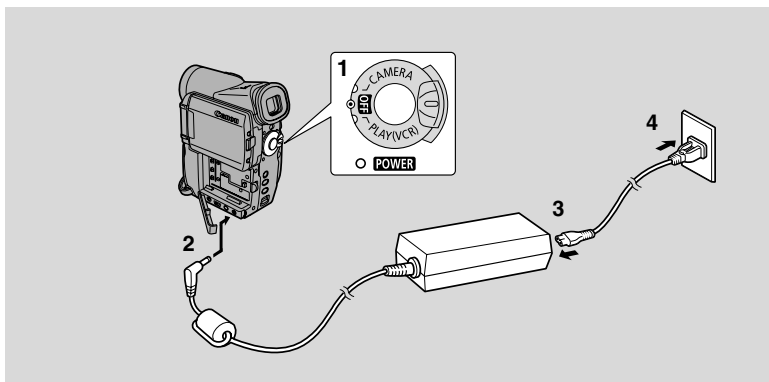

Use the power adapter to provide your camcorder with instant power from a household power socket. Always turn the camcorder off before connecting/removing the power source.

1. Set the **POWER** switch to **OFF**.
2. Connect the power adapter to the camcorder's **DC IN** terminal.
3. Connect the power cable to the power adapter.
4. Plug the power cable into a household power socket.
5. Disconnect the power adapter from the camcorder after use. Unplug the power cable from the household power socket, then disconnect it from the adapter.

## CA-PS700 Compact Power Adapter

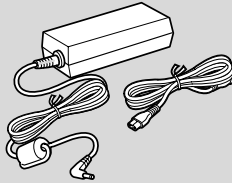

### Specifications

|                                    |                              |
|------------------------------------|------------------------------|
| <b>Power supply</b>                | 100–240 V AC, 50/60 Hz 0.32A |
| <b>Rated output</b>                | 7.4 V DC, 2.0 A              |
| <b>Operating temperature range</b> | 0°C - 40°C                   |
| <b>Dimensions</b>                  | 112 × 29 × 45mm              |
| <b>Weight</b>                      | 186g (without power cable)   |

Weight and dimensions are approximate.  
Errors and omissions excepted.  
Subject to change without notice.

## Charging the battery pack

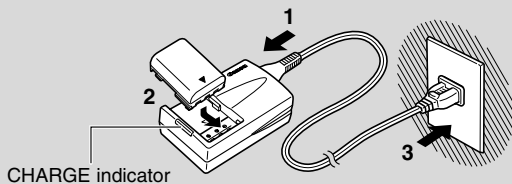

Your battery pack has been partially charged before it left the factory. It should have enough power for you to check that your camcorder is working properly. Charge the battery pack fully using the Battery Charger CB-2LTE if you want it to power the camcorder for more than a few minutes.

Always turn the camcorder off before attaching/removing the battery pack.

### 1. Connect the power cable to the charger.

### 2. Attach the battery pack to the charger.

- Align the front end of the battery pack with the guides on the charger, then press and slide the battery pack into the charger to set it in place.

### 3. Plug the AC plug into a household power socket.

- The charge indicator lights in red and charging starts.
- The indicator light changes to green when the battery pack is fully charged.

### 4. Unplug the charger from the household power socket.

### 5. Remove the battery pack by sliding it out.

### 6. Disconnect the power cable from the charger.



#### Note:

- You can find details on using the battery pack in the “Notes on Using the Battery Pack” (📖 146). These notes include charging and recording times and how to install the backup battery.

## Attaching the battery pack

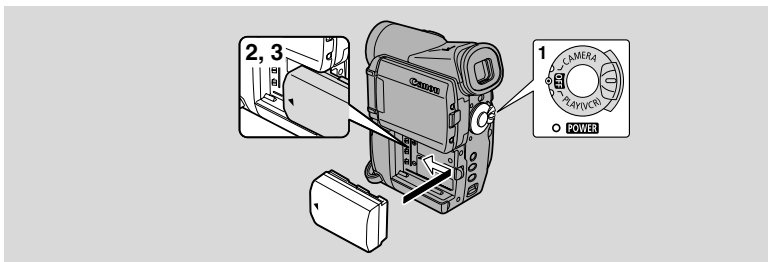

1. Turn the **POWER** switch to **OFF**.
2. Align the front end of the battery pack with the line on the camcorder, press lightly and slide the battery until it clicks into place.
3. Remove the battery pack after use.  
Press the **BATT. RELEASE** button and remove the battery.

## CB-2LTE Battery Charger

### Specifications

|                                    |   |
|------------------------------------|---|
| <b>Power supply</b>                | 100 – 240 V AC, 50/60Hz,<br>0.17A (100V) – 0.10A (240V) |
| <b>Rated output</b>                | 8.4V DC, 0.5A   |
| <b>Operating temperature range</b> | 0°C - 40°C  |
| <b>Dimensions</b>                  | 91 × 29.5 × 56 mm                                       |
| <b>Weight</b>                      | 82 g (without power cable)                              |

Weight and dimensions are approximate.  
Errors and omissions excepted.  
Subject to change without notice.

## Loading a Cassette

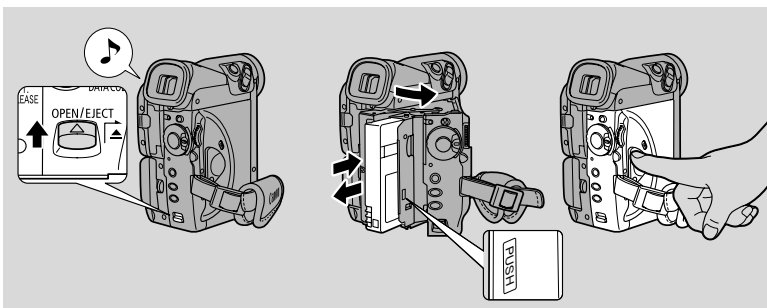



Only use videocassettes marked with the Mini DV logo.

### Loading and unloading

1. **Make sure that you have attached a power source.**
2. **Slide the OPEN / EJECT ▲ switch to release the cassette compartment cover.**
  - Pull the cover fully open (while holding the button) and wait a couple of seconds for the cassette compartment to open automatically.
  - The confirmation beep sounds when the cassette cover fully opens.
3. **Load or unload the cassette.**
  - Insert the cassette gently with the window facing outward, and the REC/SAVE tab to the bottom.
  - Remove the cassette by pulling it straight out.
4. **Press the PUSH mark on the compartment until it clicks, and wait for it to close.**
5. **Click the cover back into place.**

#### **Notes:**

- Do not interfere with the cassette compartment while it is opening or closing automatically, and do not attempt to close the cover until the cassette compartment has fully retracted.
- After loading a cassette, use record search (  38) to find the point where you want to start recording.
- Be careful not to get your fingers caught in the cassette compartment cover.
-  flashes if no cassette is inserted when turning on the power (in CAMERA and PLAY (VCR) mode).
- With some types of tapes, the remaining tape display may not give an accurate reading (  161).

## Protecting tapes from accidental erasure

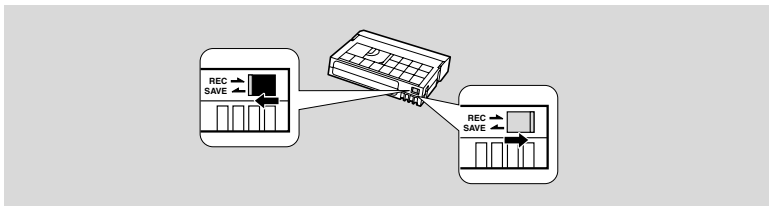

To protect your recordings from accidental erasure, slide the tab on the cassette to the left. (This switch position is usually labelled SAVE or ERASE OFF.) If you load a protected cassette in CAMERA mode, the message “THE TAPE IS SET FOR ERASURE PREVENTION” appears for approx. 4 seconds and  starts flashing. If you wish to record on that cassette, slide the tab back to the right.

## Cassette Handling Precautions

- Do not use tapes that have been jammed as video heads may become dirty.
- Rewind tapes after use. If the tape becomes slack and damaged, it may cause picture and sound distortion.
- Return cassettes in the case and store them upright.
- Do not leave the cassette in the camcorder after use.
- Do not use cassettes with spliced tapes or nonstandard cassettes as they may damage the camcorder.
- Do not insert anything into the small holes of the cassette, or cover them with cellophane tape.
- Handle cassettes with care. Do not drop or subject them to severe impact as this may damage the cassettes.
- Rewind tapes from time to time if they are stored for a long time.
- With cassettes equipped with a memory function, metal plated terminals may become dirty with use. Clean the terminals with a cotton swab after about 10 times of loading/unloading. The memory function is not supported by the camcorder.

## Recording Movies onto a Tape

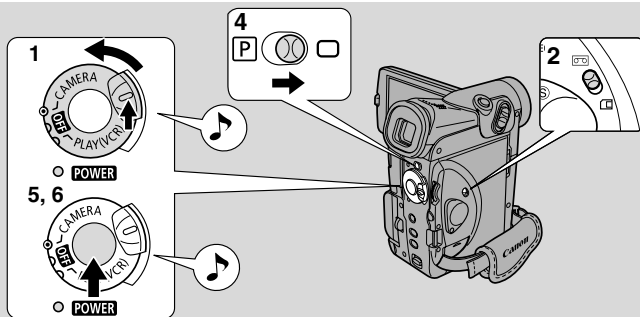
**E**

### Before you start recording

Have you completed the following steps?

- Attaching a power source ( 12 ).
- Removing the lens cap ( 145 ).
- Fastening the grip belt ( 145 ).
- Choosing the display: viewfinder ( 145 ) or LCD screen ( 25 ).



#### **Note:**

- When you're using the viewfinder, fully close the LCD or rotate the LCD so that it faces the same direction as the lens ( 25 ).

You may also want to install the backup battery ( 148 ) in order to set the date and time display ( 51 ).

### Recording

- 1. Press and hold the small button on the POWER switch and turn the POWER switch to CAMERA.**
- 2. Make sure the TAPE/CARD switch is set to TAPE.**
  - The camcorder automatically sets to record pause mode. PAUSE appears in the display.
  - If you haven't set the date and time display, SET THE TIME ZONE, DATE AND TIME appears in the display. For setting the time zone, see p. 51. For setting the date and time, see p. 53.
  - The camcorder power indicator lights up.
  - The confirmation beep sounds.
  - The camcorder will turn itself off if you leave it in record pause mode for more than about 5 minutes. To return to record pause mode, turn the POWER switch to OFF and then back to CAMERA.
  - Recording still images onto a memory card ( 107 ), recording movies onto a memory card ( 112 ).

3. **Load a cassette** (  16).
4. **Slide the program selector to** 
  - This selects the camcorder's Easy Recording program. It allows you to simply point and shoot without making any manual adjustments (  58).
5. **Press and release the start/stop button once to begin recording.**
  - For still image recording to a tape, see p. 54.
6. **Press and release the start/stop button again to pause recording.**
  - The camcorder returns to record pause mode and PAUSE reappears in the display.
  - You can stop and restart recording as often as you like by pressing the start/stop button.

**Note:**

- After loading a cassette, start recording when the tape counter has stopped.

**When you have finished recording**

- Replace the lens cap.
- Return the LCD screen flush to the camcorder body.
- Unload the cassette.
- Turn the POWER switch to OFF.
- Disconnect the power source.

**Notes:**

- To check that the camcorder is recording correctly, make a test recording first.
- Before making important recordings, clean the video heads using a Canon DVM-CL Digital Video Head Cleaning Cassette or a commercially available digital video head cleaning cassette.
- You cannot monitor the sound from the speaker when recording.
- About the built-in microphone: When recording near loud sounds (such as fireworks, drums or concerts), sound may become distorted or may be recorded not in the actual sound level.
- For tips on how to make better videos, see p. 36.
- For extra recording time, set REC MODE to LP mode (  20).

## Changing the Recording Mode



You can choose between SP (standard play) and LP (long play). LP extends the tape usage by 1.5 times.

It is not possible to dub audio or insert images to a tape that has been recorded in LP mode.

### MENU

( 39)

▶VCR SET UP

▶▶REC MODE...SP

CAMERA

PLAY (VCR)

CARD CAMERA

CARD PLAY (VCR)

**To change to LP mode, open the menu, select VCR SET UP, REC MODE and set it to LP.**



### Notes:

- Depending on the nature and usage condition of the tape, recording/playback in LP mode may cause image or sound distortion. We recommend using the SP mode for important recordings.
- We recommend recording in SP mode if you plan to transfer the images to a computer.
- If you record in both modes on the same tape, the image may become distorted during playback and the time code may not be written correctly.
- If you playback a tape recorded on another digital equipment on this camcorder, or vice versa, image and sound may become distorted.

## 16:9 (Wide screen TV recording)



Produces images in the 16:9 format for playback on wide screen TVs.

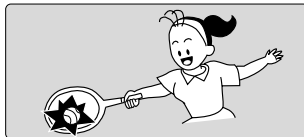

CAMERA

PLAY (VCR)

CARD CAMERA

CARD PLAY (VCR)

### MENU

( 39)

▶CAM.SET UP

▶▶16:9.....OFF

**To switch 16:9 to ON, open the menu and select CAM.SET UP. Then select 16:9, set it to ON and close the menu.**



### Notes:

- The 16:9 mode is an electronically processed effect.
- “16:9” is shown in the display when you switch the 16:9 mode on.
- You cannot use the 16:9 mode with the Easy Recording program.
- You cannot use the multi-image screen when setting the 16:9 mode on.
- If you play back a recording made for 16:9 on a normal TV screen, the image will appear to be vertically “squashed” (compressed).

## Confirmation/Warning beeps



The camcorder's short operation confirmation beeps are indicated by  in the illustrations. Beeps sound upon certain camcorder operations such as when you turn the camcorder on, during the self-timer countdown, right before the camcorder's automatic shut-off, and also upon any unusual condition of the camcorder. Beeps are not recorded on the tape.

CAMERA

PLAY (VCR)

CARD CAMERA

CARD PLAY (VCR)

**MENU**(  39)

▶ SYSTEM

▶▶ BEEP.....ON

**To turn the beep off, open the menu and select SYSTEM. Then select BEEP, set it to OFF and close the menu.**

## Demonstration mode



You can see a demonstration of the camcorder's main features. To see the demonstration, do either of the following:

- With no cassette or memory card inserted, turn the DEMO MODE on in the CAMERA menu or CARD CAMERA menu and close the menu.
- Leave the camcorder with no cassette or memory card inserted for five minutes after turning it on.

CAMERA

PLAY (VCR)

CARD CAMERA

CARD PLAY (VCR)

**MENU**(  39)

▶ DISP. SET UP

▶▶ DEMO MODE.....ON

**To turn the demonstration mode off, open the menu and select DISP. SET UP. Then select DEMO MODE, set it to OFF and close the menu.**

 **Notes:**

- To cancel the demo mode once it has begun: push any button, turn off the power, load a cassette or insert a memory card.
- The start-up image does not appear when the demonstration mode is turned off (the camcorder picture appears sooner).

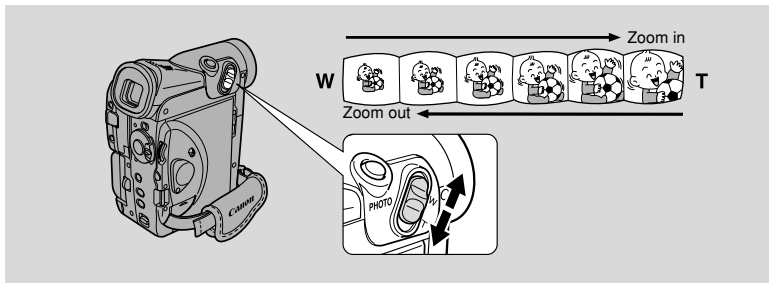

## 10× optical zoom (card 7.5×)

The camcorder's zoom lens allows you to choose the best picture angle for each scene:

- Move the zoom control towards W to zoom out to wide-angle.
- Move it towards T to zoom in to telephoto.

You can also control the speed of zooming:

- Move the control slightly to zoom slowly.
- Move it farther to zoom more quickly. (The farther you move the zoom control, the faster the zoom speed.)

The T and W buttons on the wireless controller adjust the picture angle, but not the zoom speed.

## 40×/400× digital zoom (card 30×)

Magnifies the camcorder's zoom range by up to 40× in CAMERA mode.

The zoom control continues to work as usual. You can freely zoom in and out between 1× and 400× magnification — the camcorder automatically switches between optical zooming (up to 10×) and digital zooming (10× to 40× or 10× to 400×).

CAMERA

PLAY (VCR)

CARD CAMERA

CARD PLAY (VCR)

**MENU**

( 39)

▶ CAM.SET UP

▶ D.ZOOM.....40×

**To change the digital zoom, open the menu and select CAM.SET UP. Then select D.ZOOM, set it to OFF or 400× and close the menu.**

**Notes:**

- When zooming, as a rule, keep at least 1 m between you and your subject. However when the zoom is at the wide-angle position, you can focus on a subject as close as 1 cm.
- Image resolution is slightly lower when the magnification is greater than 10 $\times$ .
- You cannot use digital zoom in the Night and Super Night recording program.
- You cannot use digital zoom when the multi-image screen is set. The display becomes “— — —”.
- The zoom indicator appears for 4 seconds. When the digital zoom is set to 40 $\times$ , the zoom indicator extends (light blue). When the digital zoom is set to 400 $\times$  zoom, the zoom indicator extends again (a darker blue).
- Because the image stabilizer cannot be used in CARD CAMERA mode, we recommend mounting the camcorder on a tripod at large magnifications.

## Using the LCD Screen

### Opening and closing the LCD screen

Slide the LCD panel OPEN button and open the panel by pulling it away from the camcorder. This automatically switches the LCD screen on and the viewfinder off. Close the LCD panel until it clicks securely closed. When you close the LCD panel, the LCD screen automatically switches off and the viewfinder switches back on.

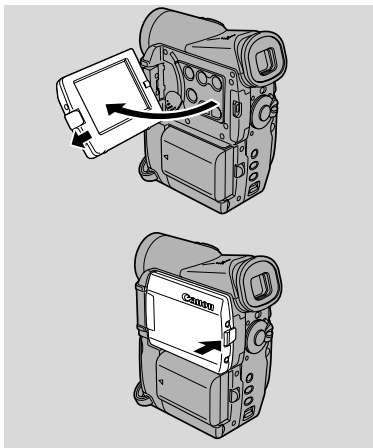

### Changing the angle of the LCD screen

You can choose the angle of the screen that suits you best by opening and rotating the screen, also you can rotate the LCD screen so that faces in the direction of the lens ( 27).

You can also push the panel flat against the camcorder until it is flush with the side, with the screen facing outwards.

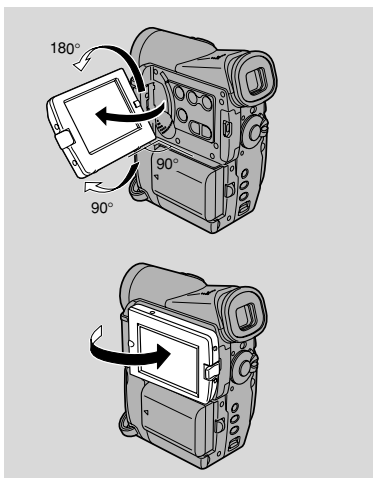

#### Notes:

- Avoid touching the LCD screen when moving the LCD panel.
- Do not hold the camcorder by the LCD panel or the viewfinder.
- Make sure you open the LCD panel at 90°, before attempting to rotate it.

- Always rotate the LCD panel vertically into place, before closing it or pushing it flat against the side of the camcorder.
- Always fully close the LCD panel until it clicks securely.
- Be careful not to leave the LCD, viewfinder or lens exposed to direct sunlight outdoors or in a window. Doing so could cause damage.
- Bright light falling on the LCD screen may cause glare that makes it difficult for you to view the image. In this case, switch to using the viewfinder. You are also able to adjust the brightness of the screen (see “Adjusting the LCD screen” below).

### Adjusting the LCD screen



You can adjust the brightness of the LCD screen.

CAMERA

PLAY (VCR)

CARD CAMERA

CARD PLAY (VCR)

**MENU**

( 39 )

▶ DISP. SET UP

▶ BRIGHTNESS •• ———+

**Open the menu and select DISP.SET UP from the menu. Then select BRIGHTNESS, adjust the level with the selector dial and close the menu.**

A bar showing the level appears in the display.

- Turn the selector dial up to make the display brighter.
- Turn the selector dial down to make the display darker.

#### **Notes:**

- The camcorder will remember your brightness setting even after you turn it off.
- The brightness of the LCD does not affect that of the recorded images or the viewfinder.

#### **About the LCD Screen**

The LCD screen built into this camcorder is a high precision product. However, small black dots or bright points of light (red, blue or green) may appear constantly on the LCD screen. This is not a malfunction of the LCD screen and they are not recorded on the tape. (Effective dots: more than 99.99%)

## Allowing the subject to monitor recording



When you turn the LCD panel so that it faces the same direction as the lens, you can watch yourself during recording or let your subject monitor recording. The viewfinder is also activated when the panel is in this position. (Adjust the viewfinder, 145)

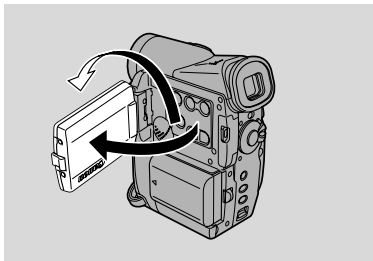

- You can choose the display style, reversed (mirror on) or not (mirror off). The recording itself is unaffected regardless of which one you choose.

CAMERA

PLAY (VCR)

CARD CAMERA

CARD PLAY (VCR)

**MENU**

( 39)

▶ DISP.SET UP

▶ LCD MIRROR...ON

**To turn the mirror mode off, open the menu and select DISP.SET UP. Then select LCD MIRROR, set it to OFF and close the menu.**

**The indicators that appear in the LCD display when LCD MIRROR is turned on:**

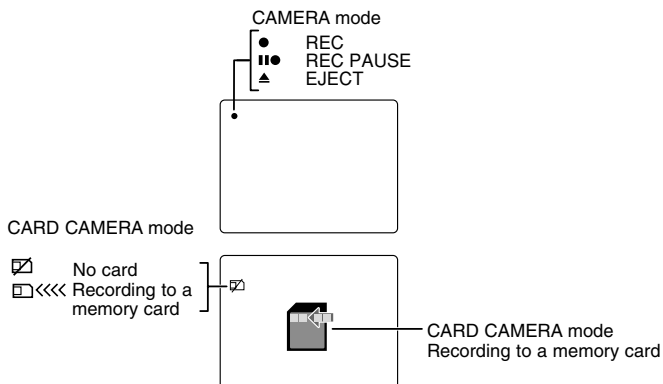

## Playing Back a Tape

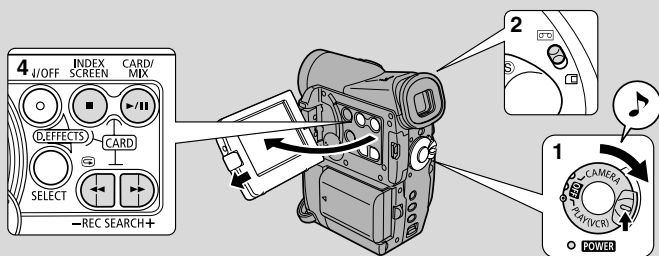

You can use the LCD screen for instant, on-the-spot playback. The camcorder also plays back the sound track via the built-in speaker (  31).

- When you play back a tape, you can also close the LCD panel with its screen side facing up.
- When you're using the viewfinder to view playback, close the LCD panel.

For playing back your recordings on a TV, see p. 32.

For using the wireless controller, see p. 48.

### Note:

- To avoid accidental recording, make sure that you slide the tab on the cassette so that it exposes the hole (the switch position is usually labelled SAVE or ERASE OFF).

### 1. Attach a power source and turn the **POWER** switch to **PLAY (VCR)**.

- The power indicator lights up.

### 2. Make sure the **TAPE/CARD** switch is set to **TAPE**.

### 3. Load the cassette.

### 4. Press the **▶** (play) button to start playback.

- To end playback, press the **■** (stop) button.
- To wind the tape forwards, stop playback and press the **▶▶** (fast forward) button.
- To wind the tape backwards, stop playback and press the **◀◀** (rewind) button.
- If the playback picture is rough (mosaic-like noise), clean the video heads using a Canon DVM-CL Digital Video Head Cleaning Cassette or a commercially available digital video head cleaning cassette.

## Other playback modes



### Playback pause

Press the **||** (pause) button. To resume normal playback, press it again, or press the **▶** (play) button. The camcorder automatically goes into stop mode after about 5 minutes' playback pause.

### Fast forward playback

To play back the recording at about 11.5 times normal speed, press and hold the **▶▶** (fast forward) button during normal playback or press and hold the **▶▶** (fast forward) button during normal fast forward.

### Rewind playback

For reverse playback at about 11.5 times normal speed, press and hold the **◀◀** (rewind) button during normal playback or press and hold the **◀◀** (rewind) button during normal rewind.

## Special playback



### Frame Advance

To play back frame by frame, press the **+ / ||▶** button repeatedly during playback pause.

Press and hold to play back continuous frame advance.

### Frame Reverse

To play back in reverse frame by frame, press the **- / ◀||** button repeatedly during playback pause.

Press and hold to play back continuous frame reverse.

### Slow Forward Playback

To play back at about 1/3 normal speed, press the **SLOW ▶** button during normal playback.

Press the **PLAY ▶** button to return to normal playback.

### Slow Reverse Playback

To play back in reverse at about 1/3 normal speed, press the **- / ◀||** button and then the **SLOW ▶** button during normal playback.

Press the **PLAY ▶** button to return to normal playback.

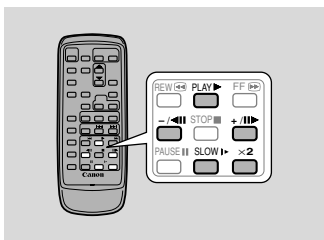

**Reverse Playback**

To play back in reverse at normal speed, press the  $-/\blacktriangleleft\|\|$  button during normal forward playback.

Press the PLAY  $\blacktriangleright$  button to return to normal forward playback.

**Forward  $\times 2$  Playback**

Press the  $\times 2$  button during normal playback.

Press the PLAY  $\blacktriangleright$  button to return to normal playback.

**Reverse  $\times 2$  Playback**

Press the  $-/\blacktriangleleft\|\|$  button and then the  $\times 2$  button during normal playback.

Press the PLAY  $\blacktriangleright$  button to return to normal playback.

**Notes:**

- Mosaic-like noise appears on the screen during some of the special playback modes.
- There's no audio during special playback.

## Built-in speaker



The camcorder has a built-in speaker so you can review the sound track alongside the picture when you're using the LCD screen to play back. The built-in speaker is monaural.

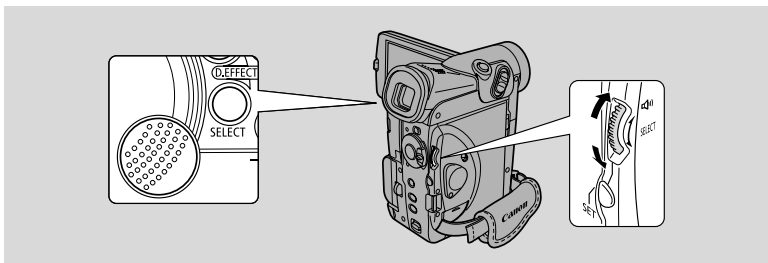

CAMERA

PLAY (VCR)

CARD CAMERA

CARD PLAY (VCR)

Adjust the speaker volume by turning the selector dial.

- Turn the selector dial up to increase the volume, and down to lower the volume.
- A bar appears in the display to indicate the current volume. It disappears in 4 seconds.
- You can turn off the volume completely by turning the selector dial down until OFF appears.



### Notes:

- Sometimes audio may sound distorted when the volume is turned up high. If this happens, turn down the volume.
- The speaker does not sound if PHONES is displayed. Set AV/headphones to AV ( 32).

## Using the headphones

- You can also use the headphones to monitor the sound track. Change the setting of the AV/headphones terminal through the menu ( 32).
- You can adjust the headphone volume separately from the built-in speaker.
- The levels you adjust for the built-in speaker and headphones are memorized separately. The camcorder remembers your levels even if you turn the camcorder off and back on again.
- The speaker turns off when you use headphones.

## Connections for Playback on a TV Screen

You can connect the camcorder to a TV or VCR in order to play back your recordings. You will need to attach a power source to the camcorder ( 12). Power off all devices before starting the connections.

See your TV or VCR instruction manual for further details.

### Switching the AV/headphone terminal

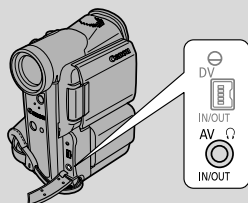

Through the menu, the camcorder's AV/headphone terminal can be switched to function as either the AV terminal or the headphone terminal.

CAMERA

PLAY (VCR)

CARD CAMERA

CARD PLAY (VCR)

**MENU**

( 39)

▶VCR SET UP

▶▶AV / PHONES...AV

**Open the menu and select VCR SET UP. Then select AV/PHONES and set it to AV or PHONES and close the menu.**

- When the terminal is switched to PHONES, PHONES appears in the display.

#### Using the headphones

- Make sure you switch the AV/headphones terminal to PHONES before using headphones. If the AV/headphones terminal is not switched to PHONES before you use the headphones, noise will come out from the headphones.

**If your TV (or VCR) has a SCART terminal (without S (S1)-video)**

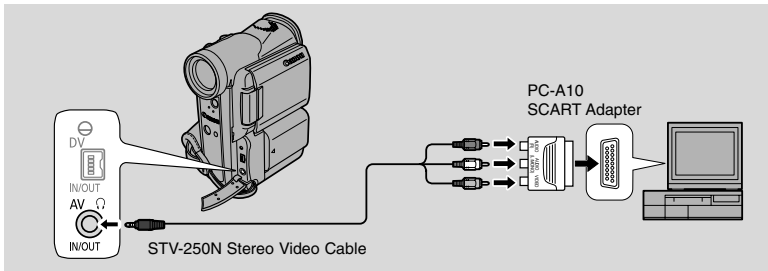

- Connect the PC-A10 SCART adapter to the TV or VCR's SCART terminal.
- Connect the camcorder to the adapter. Connect the camcorder using the STV-250N Stereo Video Cable. Connect the white plug to the white audio terminal **L** (left). Connect the red plug to the red audio terminal **R** (right). Connect the yellow plug to the yellow video terminal **VIDEO**.
- If you are connecting the camcorder to a TV, set the TV/VIDEO selector on the television to VIDEO.
- If you are connecting the camcorder to a VCR, set the input selector on the VCR to LINE.



**Note:**

- The SCART Adapter PC-A10 is for output only. For analog line-in recording or analog-digital conversion, please use a SCART adapter with input capability (commercially available).

## If your TV (or VCR) has an S (S1) -video input terminal

For higher picture quality, we recommend playing back recordings on a TV with an S (S1) terminal.

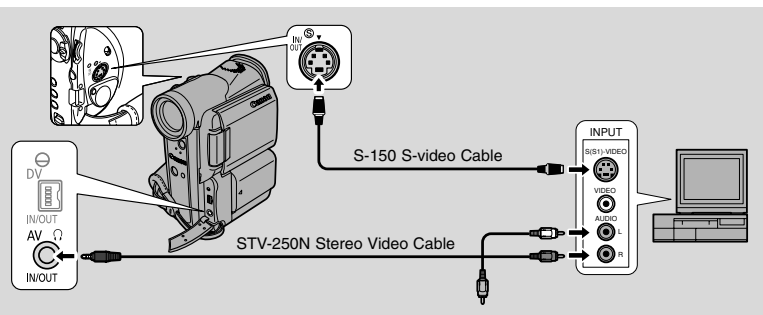

- Use the S-150 S-video Cable to connect the S-video terminals. Use the STV-250N Stereo Video Cable to connect the AUDIO terminals. Connect the white plug to the white AUDIO terminal **L** (left). Connect the red plug to the red AUDIO terminal **R** (right). Do not connect the yellow plug.
- If you are connecting the camcorder to a TV, set the TV/VIDEO selector on the television to VIDEO.
- If you are connecting the camcorder to a VCR, set the input selector on the VCR to LINE.

## If your TV (or VCR) has audio/video input terminals

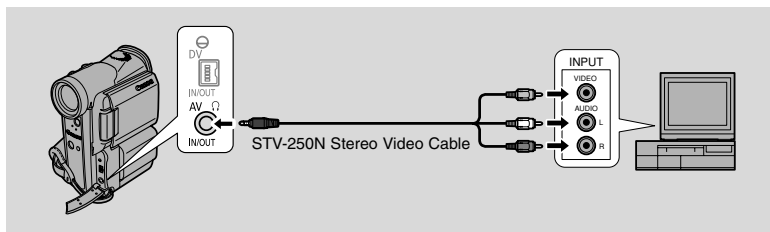

- Connect the camcorder using the STV-250N Stereo Video Cable. Connect the white plug to the white audio terminal **L** (left). Connect the red plug to the red audio terminal **R** (right). Connect the yellow plug to the yellow video terminal **VIDEO**.
- If you are connecting the camcorder to a TV, set the TV/VIDEO selector on the television to VIDEO.
- If you are connecting the camcorder to a VCR, set the input selector on the VCR to LINE.

### **Note:**

- If you are going to use the TV as a monitor while you are shooting, remember to keep the TV volume turned down as long as the camcorder's audio terminals are connected. If the sound from the TV speakers is picked up by the microphone, an unpleasant high-pitched squeal, called feedback, may be produced.

## Tips for Making Better Videos

### Holding the camcorder

For maximum stability, grip the camcorder in your right hand and keep your right elbow pressed against your body. If necessary support the camcorder with your left hand. With practice, you will be able to operate the controls by touch, without taking your eye off the action.



### Using a tripod

To prevent any unwanted movement, you can mount the camcorder on a tripod, (or any flat surface at a suitable height) and operate it with the wireless controller.

- When you are using a tripod, be careful not to leave the viewfinder exposed to bright sunlight as it may melt. (The light is concentrated by the viewfinder lens.)
- Make sure that the fastening screw of the tripod is no longer than 5.5 mm, as it will damage the camcorder.

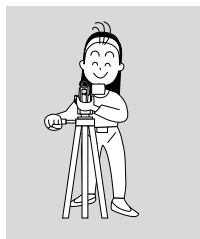

### Composition

The most important element in the scene does not have to be in the centre. For a more interesting picture, try to position your subject so it is slightly to one side. Leave some space on the side of the frame that the subject is facing or moving towards.

Don't cut off the top of the subject's head, and don't cut people off at the neck, hips or knees (move a little bit above or below).

Watch out for distracting objects in the background.



## Picture angle

Instead of zooming while recording, try to choose your picture angle before you begin. A good way to tell a story with video is to begin with a long shot that establishes the situation, and then move in with medium shots and close-ups to show the details. Remember to change your viewpoint for each shot.



Long shot



Medium shot



Close-up

Remember that any camcorder movement or change in picture angle should have a definite purpose. Avoid unnecessary or half-hearted movements.

## Camcorder moves

Use pans to record a landscape or follow a moving subject. Decide the area you want to cover and stand facing the end of your panning angle. Without moving your feet, turn your waist to the starting position. Start recording, and after a few seconds begin to turn slowly from the waist. Hold the final image for a few seconds before you stop recording.



Pan

Tilt the camcorder up to exaggerate the height of the subject. Tilt down from the top of a building, for example, as an introduction to subjects at the bottom.



Tilt

# Searching and Reviewing While Recording

## Record search



When the camcorder is in record pause mode, you can use record search to play the tape forwards or backwards to find the point where you want to start or resume recording. This is useful when you want to add a new scene to a previously used cassette. By using record search, you can ensure a smooth, noise-free join between the new scene and the old one.

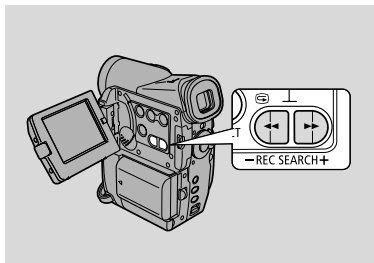

CAMERA

PLAY (VCR)

CARD CAMERA

CARD PLAY (VCR)

1. **Press and hold the REC SEARCH + or – button on the camcorder while you check the picture in the display.**
  - The + button plays the recording forwards and the – button plays it backwards.
2. **Release the button when you find the point where you want to start recording.**
  - The camcorder returns to record pause mode.

## Record review



When the camcorder is in record pause mode, you can use record review to play back the last few seconds of your recording and then return automatically to record pause mode. You can quickly make sure that a scene has been recorded properly and then go on to shoot the next scene, without producing any noise in the picture.

CAMERA

PLAY (VCR)

CARD CAMERA

CARD PLAY (VCR)

1. **Press and release the  (record review) button while you check the picture in the display.**
  - The camcorder rewinds the tape, plays back the last few seconds, and returns to record pause mode.



### Note:

- Noise may appear on the screen when you play the tape backwards.

# Using the Menus



E

Many of the camcorder's advanced functions are selected from menus which appear in the display.

There are 4 main menus:

|              |                  |       |
|--------------|------------------|-------|
| CAM. MENU    | Camera menu      | ( 41) |
| VCR MENU     | VCR menu         | ( 42) |
| C. CAM. MENU | Card camera menu | ( 44) |
| C. PLAY MENU | Card play menu   | ( 45) |

## ● CAMERA CAM. MENU

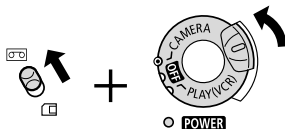
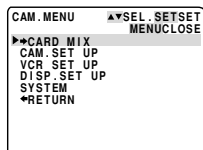

## ● PLAY (VCR) VCR MENU

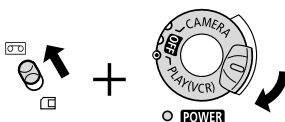
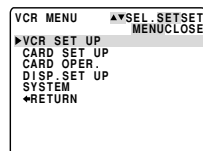

## ● CARD CAMERA C. CAM. MENU

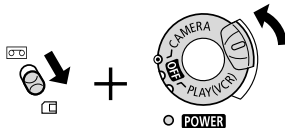
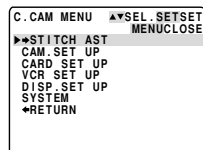

## ● CARD PLAY (VCR) C. PLAY MENU

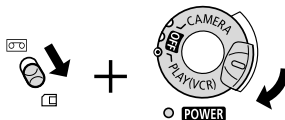
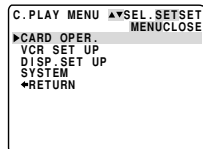

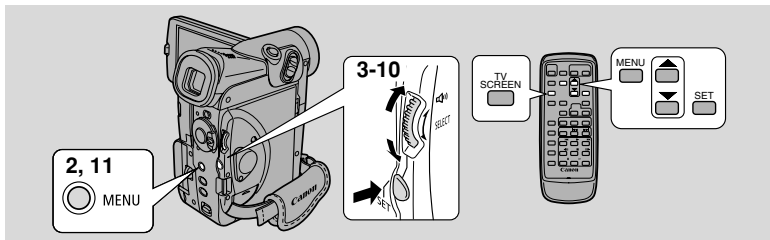

1. Turn the **POWER** switch and the **TAPE/CARD** switch to the desired settings.
2. Press the **MENU** button to open the menu.
3. Turn the selector dial and move the arrow to the desired submenu.
4. Press the **SET** button to select.
  - The submenu appears.
5. Turn the selector dial and move the arrow to the desired function.
6. Press the **SET** button to select.
  - The function and its settings only appear.
7. Turn the selector dial and move the arrow to the desired setting.
  - If you are setting a function other than the white balance or shutter speed, the function will be set if you skip to step 11.
8. Press the **SET** button to select.
  - The function is set and you return to the submenu.
9. Turn the selector dial and move the arrow to **← RETURN**.
10. Press the **SET** button to select.
  - You return to the main menu.
11. Press the **MENU** button.
  - The main menu disappears.

**Notes:**

- Pressing the **MENU** button at any time closes the menu.
- Selecting **← RETURN** takes you back one menu, or closes the main menu.
- Items that are unavailable, due to the tape or card situation or the settings of other menu items, appear in purple.
- You may often find it convenient to use the wireless controller to move around the menus. Press its **MENU** button to open/close the menu and use the arrow keys in place of turning the selector dial. Push the **SET** button to select.

- Pressing the start/stop button or the PHOTO button will close the menu and start recording.
- You can display the menus on a connected TV screen by turning TV SCREEN ( 160) on through the menu or using the wireless controller's TV SCREEN button. See p. 32 for TV connecting instructions.

## List of Menus



Turn to appropriate page for a detailed explanation of each function.

### CAM. MENU

CAMERA

- To card mix submenu
- To camera set up submenu
- To VCR set up submenu
- To display set up submenu
- To system menu
- Close main menu

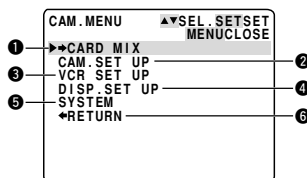

#### 1 Card mix submenu

- Mix type..... 136
- Mix level..... 136

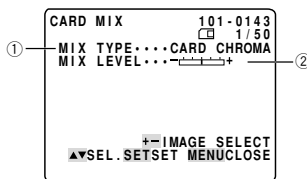

#### 2 Camera set up submenu

- Shutter speed..... 74
- Digital zoom..... 23
- Image stabilizer..... 56
- 16:9 effect..... 21
- White balance..... 77
- Self-Timer..... 71
- Return

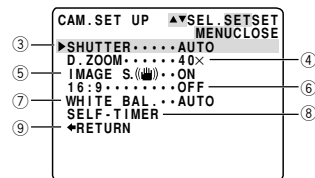

**CAM. MENU, cont.****3 VCR set up submenu**

- 10 Recording mode..... 20
- 11 Wind screen ..... 70
- 12 Audio mode ..... 69
- 13 AV or headphones..... 32
- 14 Return

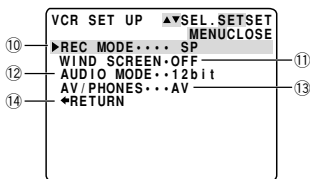
**4 Display set up submenu**

- 15 Brightness ..... 26
- 16 LCD Mirror mode..... 27
- 17 TV screen..... 160
- 18 Date/time display ..... 53
- 19 Card access display..... 104
- 20 Demo mode..... 22
- 21 Return

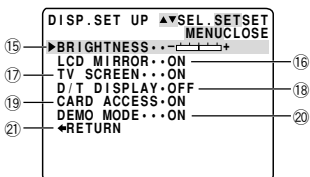
**5 System submenu**

- 22 Wireless controller..... 49
- 23 Tally Lamp..... 50
- 24 Beep ..... 22
- 25 Time zone/  
Daylight saving time..... 51
- 26 Date/time set..... 53
- 27 Return

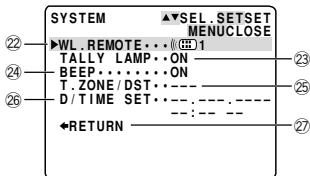
**VCR MENU** PLAY (VCR)

- 1 To VCR set up submenu
- 2 To card set up submenu
- 3 To card operations submenu
- 4 To display set up submenu
- 5 To system submenu
- 6 Close main menu

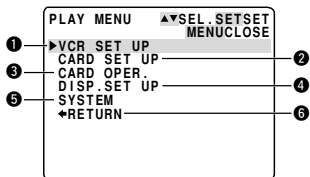

## 1 VCR set up submenu

- ① Recording mode..... 20
- ② Output channel..... 100
- ③ Audio dubbing..... 97
- ④ Wind screen..... 70
- ⑤ Audio mode..... 69
- ⑥ AV or headphones..... 32
- ⑦ Analog-digital converter..... 92
- ⑧ Return

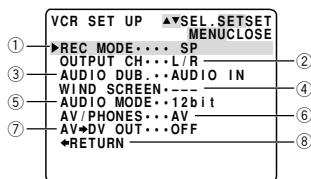

## 2 Card set up submenu

- ⑨ Still image quality..... 103
- ⑩ Movie Size..... 103
- ⑪ File numbers..... 105
- ⑫ Return

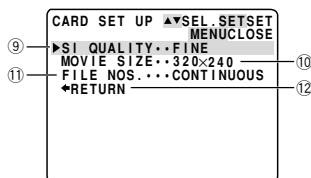

## 3 Card operations submenu

- ⑬ Copy from tape to card..... 138
- ⑭ Return

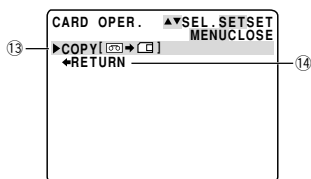

## 4 Display set up submenu

- ⑮ Brightness..... 26
- ⑯ Displays..... 160
- ⑰ 6-second auto date..... 82
- ⑱ Data code..... 81
- ⑲ Date/time select..... 80
- ⑳ Card access display..... 104
- ㉑ Return

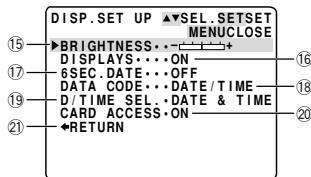

## VCR MENU, cont.

### 5 System submenu

- 22 Wireless controller..... 49
- 23 Tally Lamp..... 50
- 24 Beep..... 22
- 25 Time zone/  
Daylight saving time..... 51
- 26 Date/time set..... 53
- 27 Return

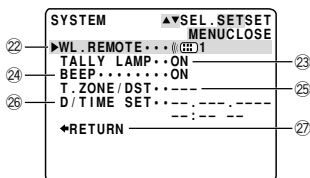

## C. CAM MENU CARD CAMERA

- 1 To stitch assist mode
- 2 To camera set up submenu
- 3 To card set up submenu
- 4 To VCR set up submenu
- 5 To display set up submenu
- 6 To system submenu
- 7 Close main menu

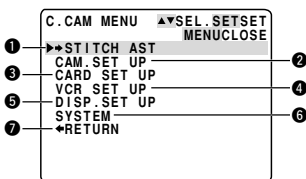

### 2 Camera set up submenu

- 1 Shutter speed..... 74
- 2 Digital zoom..... 23
- 3 White balance..... 77
- 4 Self-timer..... 71
- 5 Return

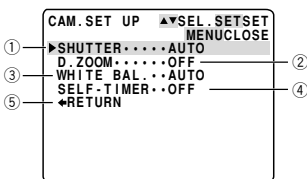

### 3 Card set up submenu

- 6 Still image quality..... 103
- 7 Still image size..... 103
- 8 Movie size..... 103
- 9 File numbers..... 105
- 10 Shutter sound..... 106
- 11 Return

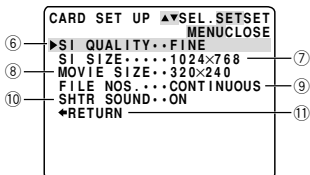

**4 VCR set up submenu**

- ⑫ AV or headphones..... 32

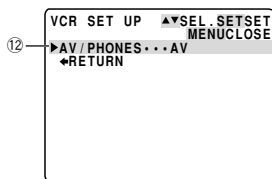
**5 Display set up submenu**

- ⑬ Brightness ..... 26  
 ⑭ LCD Mirror mode..... 27  
 ⑮ TV screen..... 160  
 ⑯ Date/time display ..... 53  
 ⑰ Card access display..... 104  
 ⑱ Demo mode..... 22  
 ⑲ Return

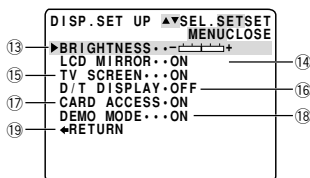
**6 System submenu**

- ⑳ Wireless controller..... 49  
 ㉑ Tally Lamp..... 50  
 ㉒ Beep..... 22  
 ㉓ Time zone/  
     Daylight saving time..... 51  
 ㉔ Date/time set..... 53  
 ㉕ Return

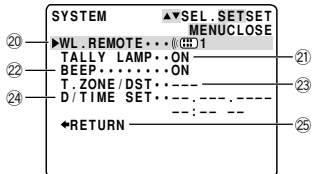
**C. PLAY MENU** CARD PLAY (VCR)

- ① To card operations submenu  
 ② To VCR set up submenu  
 ③ To display set up submenu  
 ④ To system submenu  
 ⑤ Close main menu

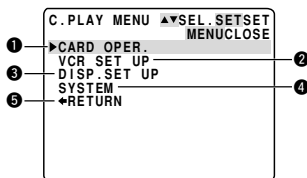



#### 4 System submenu

- ⑰ Wireless controller ..... 49
- ⑱ Tally Lamp ..... 50
- ⑲ Beep ..... 22
- ⑳ Time zone/  
Daylight saving time ..... 51
- ㉑ Date/time set ..... 53
- ㉒ Return

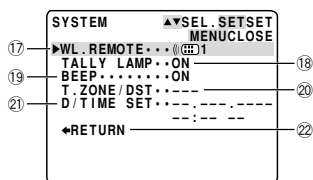

- #### 5 Direct Printing Mode
- (Appears when connecting a printer with direct print function.)  
..... 128

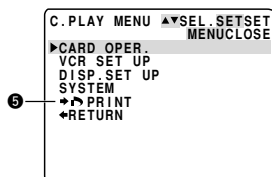

## Using the Wireless Controller



The supplied wireless controller can operate the camcorder from a distance of up to 5 m. Point it at the camcorder's remote sensor while you press the buttons.

The tally lamp lights up to let you know that the camcorder is in range and responding to your commands.

There are some functions that cannot be operated without the wireless controller:

- Special playback ( 29)
- Photo/date search ( 83)
- Zero set memory ( 84)
- Audio mix ( 99)
- Dubbing from a digital video equipment ( 86)
- Analog line-in ( 89)
- AV insert ( 93)
- Audio dubbing ( 96)

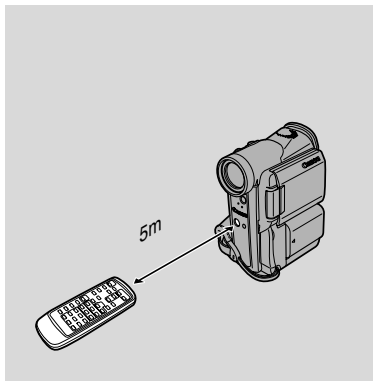

### Inserting batteries

Insert two AA batteries, following the  $\oplus$  and  $\ominus$  markings. Be careful not to reverse the polarity of the batteries.

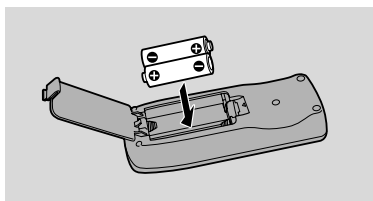

#### Notes:

- When using the wireless controller in brightly lit places or outdoors, the effective range will be less.
- The camcorder may have difficulty picking up the remote control signals at extremely close range.
- Do not leave the controller exposed to direct sunlight, or in hot or humid places.
- When the batteries run out, replace them both together.
- If the wireless controller doesn't work, see p. 50.

## When Operating 2 Canon DV Camcorders (Remote Sensor Mode)

To prevent interference from other Canon wireless controllers being used nearby, there are 2 remote sensor modes and an off setting. The wireless controller and the camcorder have to be set to the same mode in order to be compatible.

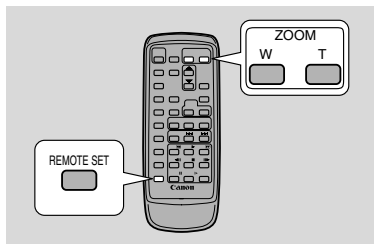

The wireless controller and the camcorder have been preset to mode 1. If you change the mode on the camcorder, be sure to change the mode on the wireless controller to the same mode.

CAMERA

PLAY (VCR)

CARD CAMERA

CARD PLAY (VCR)

**MENU**

( 39)

►SYSTEM

►WL.REMOTE... ( 1)

( 1) : Mode 1

( 2) : Mode 2

OFF ( ) : Sensor off

To turn the remote sensor off:

**Open the menu and select SYSTEM. Then select WL.REMOTE, set it to OFF and close the menu.**

- ( ) appears in the display.

To change the mode...

...on the camcorder:

**Open the menu and select SYSTEM. Then select WL.REMOTE, set it to ( 1) or ( 2) and close the menu.**

- The selected mode will appear on the display for 4 seconds.

...on the wireless controller:

**Press and hold the REMOTE SET button on the wireless controller. Simultaneously press the ZOOM W button for mode 1 or the ZOOM T button for mode 2. Continue to press simultaneously for over 2 seconds.**

- Be sure to set the wireless controller to the same mode as the camcorder.

### If your wireless controller isn't working:

Make sure the camcorder and the wireless controller are both set to the same mode. Check the mode the camcorder is set to by pushing any button other than the REMOTE SET button on the wireless controller. The camcorder's mode appears in purple for about 4 seconds. Set the wireless controller's mode accordingly by pressing the aforementioned button combinations. If the wireless controller still doesn't work, change the batteries.

#### Notes:

- The mode the camcorder is set to also appears for 4 seconds when you turn the power on.
- When you replace the batteries, the wireless controller returns to mode 1. Change the mode again if necessary.

### Turning off the tally lamp



The tally lamp lets you know that the camera is recording, receiving signals from the wireless controller or counting down for the self-timer. However, its flashing may be reflected into the lens during close-up recording, or when recording through glass.

You may therefore decide to turn it off.

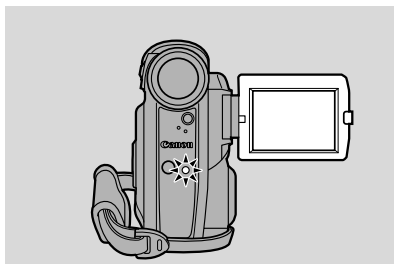

CAMERA

PLAY (VCR)

CARD CAMERA

CARD PLAY (VCR)

**MENU**(  39)

▶ SYSTEM

▶▶ TALLY LAMP •• ON

**To turn the tally lamp off, open the menu and select SYSTEM. Then select TALLY LAMP, set it to OFF and close the menu.**

- The tally lamp no longer flashes during recording, but it will still light up when the camera receives a signal from the wireless controller and during the self-timer countdown.

## Setting the Date and Time

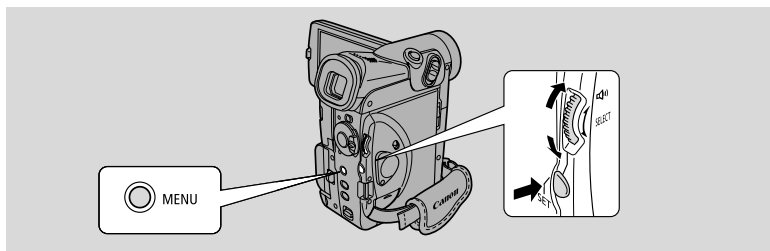

The date and/or time display forms part of the data code. You can choose to display or hide it during playback ( 80).

Set the date and time display when you first start using your camcorder. Install the backup battery before you begin ( 148).

- Before you start setting the date and time, select your home time zone from the menu.

### Setting the time zone/daylight saving time



CAMERA

PLAY (VCR)

CARD CAMERA

CARD PLAY (VCR)

**MENU**

( 39)

▶ SYSTEM

▶ T.ZONE / DST • • PARIS

1. **Open the menu and select SYSTEM and press the SET button.**
2. **Select T.ZONE/DST and press the SET button.**
  - The time zone display appears on the screen.
  - Your camcorder's time zone is factory-preset to Paris. If you are at another time zone, select your time zone first and daylight saving time (DST) setting if necessary.
3. **Move up or down the list of time zones with the selector dial. Select the option that represents your time zone and press the SET button.**
  - If you are now in daylight saving time, select the time zone with the daylight saving time mark \* next to the area.
4. **Close the menu.**

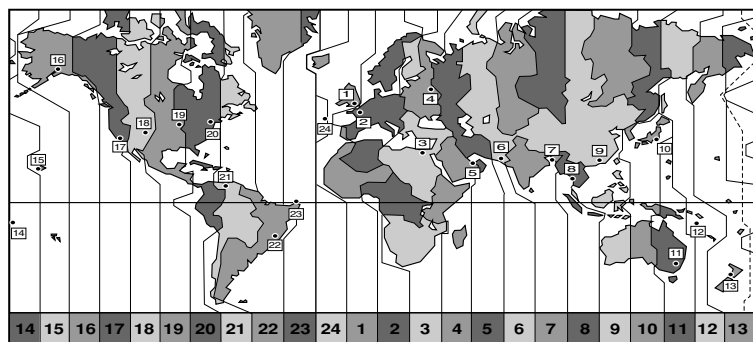

| No. | Time zone           | No. | Time zone                     |
|-----|---------------------|-----|-------------------------------|
| 1   | LONDON              | 13  | WELLGTN (Wellington)          |
| 2   | PARIS               | 14  | SAMOA                         |
| 3   | CAIRO               | 15  | HONOLU. (Honolulu)            |
| 4   | MOSCOW              | 16  | ANCHOR. (Anchorage)           |
| 5   | DUBAI               | 17  | L.A. (Los Angeles)            |
| 6   | KARACHI             | 18  | DENVER                        |
| 7   | DACCA               | 19  | CHICAGO                       |
| 8   | BANGKOK             | 20  | N.Y. (New York)               |
| 9   | H. KONG (Hong Kong) | 21  | CARACAS                       |
| 10  | TOKYO               | 22  | RIO (Rio de Janeiro)          |
| 11  | SYDNEY              | 23  | FERNAN. (Fernando de Noronha) |
| 12  | SOLOMON             | 24  | AZORES                        |



### Notes:

- After you have selected your time zone and set the date and time, when you travel to another time zone, there is no need to reset the date and time. Just set the time zone to your destination and the camcorder's clock will automatically change to display the correct time for your destination.
- The camcorder automatically accounts for the number of days in a month and leap year.

## Setting the clock



After you set the date and time, the date/time and home time zone will be displayed for about 4 seconds each time you turn the power on.

CAMERA

PLAY (VCR)

CARD CAMERA

CARD PLAY (VCR)

**MENU**

(□ 39)

▶ SYSTEM

▶▶ D/TIME SET ·· 1. JAN, 2003  
12:00 AM

1. Open the menu and select **SYSTEM**.
2. Select **D/TIME SET** and press the **SET** button.
  - The year display starts to flash.
3. Turn the selector dial up and down to change the year. Press the **SET** button to move to another part of the display.
  - Once you move from the year, the next part of the display starts flashing.
4. Set the month, day, hours, and minutes in the same way.
5. Press the **MENU** button when finished, and to start the clock.



### Notes:

- To make a change to part of the date and time, press the **SET** button at step 3 to move to the part to be changed. Turn the dial to make the change, then close the menu.
- The date can be set to any year between 2003 and 2030.
- If you press the **MENU** button in the middle of setting the date and time, you leave the menu, and the clock starts.
- If you press the **SET** button after setting the minutes you can set the date and time again from the start.

## Date and time display



You can choose to display or hide the date and time display during recording. When the date and time display is set to **ON**, date and time are shown in the lower left-hand corner of the display but the time zone disappears in about 4 seconds. The large, 4-second display will no longer appear when you turn on the power. It is not automatically superimposed on your recordings.

CAMERA

PLAY (VCR)

CARD CAMERA

CARD PLAY (VCR)

**MENU**

(□ 39)

▶ DISP. SET UP

▶▶ D/T DISPLAY · OFF

**To turn it on, open the menu and select DISP.SET UP. Then select D/T DISPLAY, set it to ON and close the menu.**

## Recording Still Images onto a Tape



To take still images on a memory card, see p. 107.

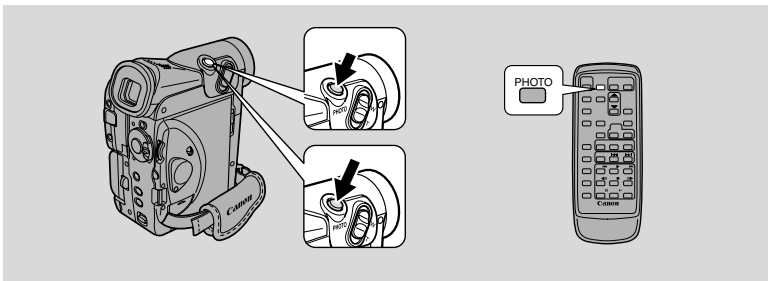

You can record still images like photographs. The camcorder records the picture and sound to tape for several seconds. The exposure is automatically adjusted. Copy still images automatically to a memory card (□ 138) for transfer to a PC for image enhancement and printout. Also, starting your shooting with a still image makes it easy to find the beginning again later with the Photo Search function(□ 83).

You can take a still image at any time during regular video recording, or you can put the camcorder into record pause mode first, then take a still image.

CAMERA

PLAY (VCR)

CARD CAMERA

CARD PLAY (VCR)

During record mode





**Press the PHOTO button fully down and the still image will be taken immediately.**

- The camcorder takes the image immediately, and then records the “photo” to the tape for approximately 6 seconds. During this time the camcorder also records the sound, and the display shows the still image.
- A counter display appears, and counts up as the camcorder records the image.
- The camcorder returns to record pause mode.

During record pause mode

**1. Press the PHOTO button halfway down and hold it.**

- “PHOTO” flashes at the bottom right of display.
- Exposure is locked.
- During autofocus ● flashes white in the display as the camcorder adjusts the focus and it is displayed continuously as a green mark when the camcorder is ready to take the still image.

- If the subject is unsuitable for autofocus (  154), the camcorder may not be able to focus, and  may continue to flash white in the display. Continue to hold the PHOTO button halfway down, then adjust the focus manually with the selector dial.
- If you are using manual focus (  76), the  mark starts as a continuous green mark. Focus with the selector dial.

## 2. Press the PHOTO button fully down to take the still image.

- The camcorder takes the image immediately, and then records the “photo” to the tape for approximately 6 seconds. During this time the camcorder also records the sound, and the display shows the still image.
- A counter display appears, and counts up as the camcorder records the still image.  disappears from the display.
- The camcorder returns to record pause mode.



### Notes:

- The camcorder automatically returns to record pause mode after recording a still image for approximately 6 seconds. If you turn the POWER switch to OFF during that time, the camcorder will respond only after recording is complete.
- The wireless controller’s PHOTO button has no half-way setting. Press the button fully and the camcorder immediately takes the “photo”.
- Record still images under sufficient lighting condition (in which you can identify the subject on the screen).

## Turning the Image Stabilizer Off

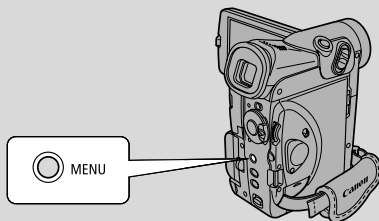

With most camcorders, even the slightest hand movements will be noticeable during telephoto recording. However, the MV6i MC image stabilizer allows you to obtain steady recordings even at high magnification.

- The image stabilizer cannot be used in CARD CAMERA mode.

CAMERA

PLAY (VCR)

CARD CAMERA

CARD PLAY (VCR)

**MENU**

( 39)

▶ CAM.SET UP

▶▶ IMAGE S. ( ) • ON

**To turn the image stabilizer off, open the menu and select CAM.SET UP. Then select IMAGE S. ( ), set it to OFF and close the menu.**

- The ( ) mark disappears from the display when the stabilizer is off.
- The image stabilizer cannot be turned off when the program selector is set to the □ (Easy Recording) position.

### **Notes:**

- Keep the image stabilizer turned off when the camcorder is mounted on a tripod.
- The image stabilizer is designed to deal with a normal degree of camcorder shake.
- The image stabilizer may not be as effective as usual during the Low Light, Night and Super Night mode.

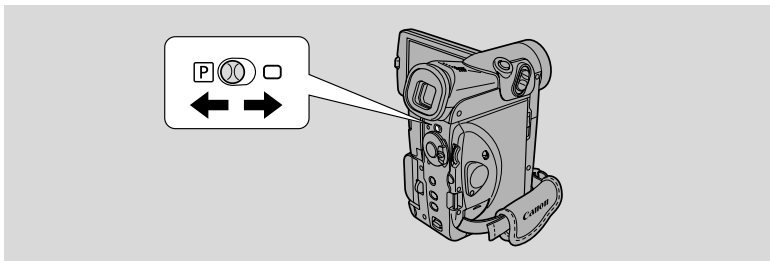

The camcorder is equipped with the Easy Recording program and several program AE modes. The availability of functions differs depending on the selected mode.

- For simple point-and-shoot operation, select the Easy Recording program. Slide the program selector to the □ position.
- For normal shooting conditions, slide the program selector to **P** (program AE) mode. Open the program menu and select AUTO (□ 58).
- For various other recording conditions, the camcorder has additional specialised AE (auto exposure) programs.

## Availability of functions in each recording program

| Recording Program                | □ (Easy Recording) | Auto     | Sports | Portrait | Spotlight | Sand & Snow | Low Light | Night | Super Night | Low Light Plus |   |
|----------------------------------|--------------------|----------|--------|----------|-----------|-------------|-----------|-------|-------------|----------------|---|
| Position of program selector     | □                  | <b>P</b> |        |          |           |             |           |       |             |                |   |
| Position of the TAPE/CARD switch | □/□                |          |        |          |           |             |           | □     | □           |                |   |
| Digital Zoom                     | ○                  | ○        |        |          |           |             | ×         |       | ○           |                |   |
| Shutter speed                    | A                  | ○        | A      |          |           |             |           |       |             |                |   |
| Focus                            |                    | ○        |        |          |           |             |           |       |             |                |   |
| White balance                    |                    | ○        |        |          |           |             |           |       |             |                |   |
| AE shift                         |                    | ○        |        | ×        | ○         | ×           | ○         |       |             |                |   |
| Image stabilizer*1               | ON                 | ○        |        |          |           |             | ×         |       |             |                |   |
| Digital effects*2                | ×                  | ○        |        |          |           |             |           |       |             |                |   |
| 16:9*1                           |                    | ○        |        |          |           |             |           |       |             | ×              | × |
| Card mix*1                       |                    | ○        |        |          |           |             |           |       |             | ×              | × |

○ : Available    × : Not available    A : Automatic function only

\*1 Can be used only when the TAPE/CARD switch is set to □.

\*2 Only Black and White can be used in CARD CAMERA mode.

You cannot use the multi-image screen in the Night and Super Night recording program.

## Setting the program AE mode



CAMERA

PLAY (VCR)



CARD CAMERA

CARD PLAY (VCR)

1. Slide the program selector to  (program AE) mode.
2. Press the SET button to display the program menu.
3. Turn the selector dial to move the arrow up or down the display.
4. Press the SET button to select the desired program.
  - The program will appear in the display.



### Notes:

- The name of your selected recording program appears constantly on the left of the display, with the exception of Auto, which is displayed and then disappears after 4 seconds.
- Avoid changing programs during recording as the brightness of the image may change suddenly.
- If you switch the camcorder from the  program to the  program, the camcorder returns to the Auto mode.
- When recording in dark places a bright light in the scene may cause a vertical light bar (“smear”) to appear. This is a normal feature of camcorders.



## Easy Recording Program

The camcorder adjusts focus, exposure and other settings automatically, allowing you to just point and shoot.



## Program AE Modes

### Auto

The camcorder adjusts focus, exposure and other settings automatically. However, you have the option of adjusting the settings manually.



## Sports

---

Use this mode to record sports scenes (such as tennis or golf), moving objects (such as roller coasters) or when recording from a moving car.

- This mode is set at a high shutter speed and should therefore be used in sufficient light.
- This mode is mainly intended for frame-by-frame or slow playback. The picture may not appear smooth when played back in normal speed.



## Portrait

---

Use this mode to give accent to your subject by blurring the background or foreground.

- The blur effect increases the more you zoom to telephoto.
- This mode is set at a higher shutter speed. The picture may not appear smooth when played back.



## Spotlight

---

Use this mode to record spotlit scenes such as shows, recitals or fireworks.



## Sand & Snow

---

Use this mode in bright places such as a sunny beach or ski resort. It prevents the subject from being underexposed.

- The subject may become overexposed in dark surroundings. Check the image on the screen.
- This mode is set at a higher shutter speed. The picture may not appear smooth when played back.



## Low Light

---

Use this mode to record in dimly lit places. The shutter is fixed at a slow shutter speed.

- Moving subjects may leave a trailing afterimage.
- Picture quality may not be as good as in other modes.
- The camcorder may have difficulty to focus automatically.



## Night (CAMERA mode)

---

In CAMERA mode, use this mode to record in dark places. The shutter speed is adjusted automatically. It is useful when recording in places with changing light conditions (such as in amusement parks).

- Moving subjects may leave a trailing afterimage.
- Picture quality may not be as good as in other modes.
- White points may appear on the screen.
- Autofocus may not work as well as in other modes.

In such case, adjust the focus manually.



## Super Night (CAMERA mode)

---

In CAMERA mode, use this mode to record in very dark places. The shutter speed is adjusted automatically. The White LED lights up automatically responding to the surrounding brightness and illuminates the subject in the center of the screen, allowing you to record brightly in color.



## Low Light Plus (CARD CAMERA mode)

---

In CARD CAMERA mode, use this mode to record in dark places. The shutter is fixed at a slow shutter speed. The White LED lights up illuminating the subject in the centre of the screen, allowing you to record brightly in colour.





Concerning Super Night and Low Light Plus modes:

- The range of the White LED is limited. Check the image on the screen when recording.
  - Use this mode for recordings at close range (up to 2m).
  - Moving subjects may leave a trailing afterimage.
  - Picture quality may not be as good as in other modes.
  - White points may appear on the screen.
  - Autofocus may not work as well as in other modes.
- In such case, adjust the focus manually.

## Using Digital Effects

Use the camcorder's digital effects for more interesting productions.

- Faders:** Start or end scenes on a tape with a fade to or from black (  62). Fade Trigger, Wipe, Corner, Jump, Flip, Puzzle, Zigzag, Beam, Tide
- Effects:** Add flavour to your recordings (  64). Art, Black and White, Sepia, Mosaic, Ball, Cube, Wave, Color Mask, Mirror
- Multi-image Screen:** Divides the display to show 4, 9 or 16 still images. Has 4 transition speed options: fast, moderate, slow and manual (  67).

### Availability of digital effects by mode



|                    | CAMERA | PHOTO | PLAY (VCR) | CARD CAMERA | CARD PLAY (VCR) |
|--------------------|--------|-------|------------|-------------|-----------------|
| Faders             | ○      | ×     | ○          | ×           | ×               |
| Effects            | ○      | ○     | ○          | ○ *1        | ×               |
| Multi-image Screen | ○ *2   | ○ *2  | ○          | ×           | ×               |

○ : Available      × : Not available

\*1 : Black and White only

\*2 : Cannot be used in Night and Super Night recording program.

#### **Notes:**

- When you do not want to use digital effects, press the D.EFFECTS SELECT button and select D.EFFECT **OFF** from the digital effects menu. Press the D.EFFECTS SELECT button to close the menu.
- The camcorder remembers your chosen digital effect setting until you change it.
- Digital effects can be selected but not operated on a blank blue screen (appears in PLAY (VCR) mode). The display continues to flash.
- Digital effects operated during PLAY (VCR) mode are not recorded onto the original tape.
- Digital effects can be added to another tape when dubbing using the AV out terminal (PLAY (VCR) mode), but not the DV out terminal.
- You cannot operate digital effects while photo/date searching.
- If you slide the program selector to  (Easy Recording) while the digital effect display is flashing, it will disappear from the display and reappear when you return to  (program AE) mode.
- The digital effect display will flash for 2 seconds after setting, even if DISPLAYS is set to OFF in the menu.
- The image quality may be slightly lower with digital effects.

## Faders

### Fade Trigger (FADE-T)

The image gradually fades in.



The image gradually fades out.

### Wipe (WIPE)

The image begins as a thin vertical line in the centre of the screen and expands sideways until it fills the whole screen.



The image is wiped off from both sides of the screen.

### Corner Wipe (CORNER)

The image appears from the corners until it fills the whole screen.



The image is wiped off from the corners.

### Jump (JUMP)

A small image appears from the left, jumps into the centre and enlarges until it fills the whole screen.



The image shrinks, jumps from the centre to the left and disappears.

### Flip (FLIP)

The image flips into the screen.



The image flips out of the screen.

## Faders

### Puzzle (PUZZLE)

The image appears in 16 pieces.  
The pieces move around until the puzzle is solved.



The image divides into 16 pieces.  
The pieces move around and disappear.

### Zigzag (ZIGZAG)

The image appears in zigzag  
from the top of the screen.

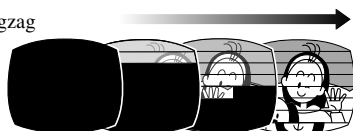

White stripes appear in zigzag from  
the bottom of the screen until they  
cover the whole image.

### Beam (BEAM)

The screen turns yellow, forms  
a beam and the full image appears.

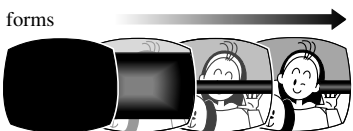

A yellow beam appears in the middle  
of the screen and expands until it  
covers the whole image.

### Tide (TIDE)

The image appears from both  
sides like tides.

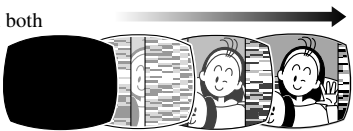

The image disappears from both  
sides like tides.

## Effects

### Art (ART)

The image becomes like a paint (solarization).

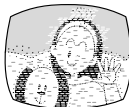

### Black and White (BLK & WHT)

The image becomes black and white.



### Sepia (SEPIA)

The image becomes monochrome with a brownish tint.



### Mosaic (MOSAIC)

The image is blurred through enlarging the size of some pixels.

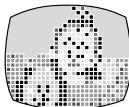

### Ball (BALL)

The image becomes like a ball.



### Cube (CUBE)

The image becomes a cube and rotates.



### Wave (WAVE)

Both ends of the image sway in waves.



### Colour Masking (COLOR M.)

The image becomes a rhombus surrounded by a masking frame that changes the colours.



### Mirror (MIRROR)

Creates a symmetrical image as if there would be a mirror in the centre of the screen.



#### Note:

- Only Black and White can be used in CARD CAMERA mode.

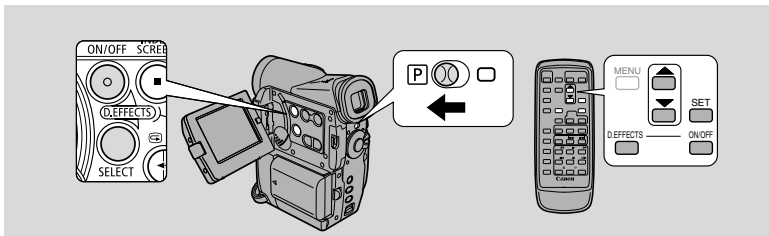

## Operating faders



Sound and image fade together.

When operating faders in CAMERA mode, make sure the program selector is set to **P**.

CAMERA

PLAY (VCR)

CARD CAMERA

CARD PLAY (VCR)

Select fader

1. **Press the D.EFFECTS SELECT button to open the digital effects menu.**
  - D.EFFECT **Off**, FADER, EFFECT and MULTI-S appear.
2. **Select FADER.**
  - The settings appear. Select the setting by turning the selector dial.
3. **Select the desired setting.**
  - You return to the digital effects menu.
4. **Press the D.EFFECTS SELECT button to close the menu.**
  - The name of your selected fader flashes in the display.

Fader on/off

5. **Press the D.EFFECTS ON/OFF button.**
    - The name of your selection stops flashing.
    - Each time you press the ON/OFF button, the chosen fader is activated (display lights continuously) or deactivated (display flashes).
  6. **If you're in CAMERA mode:**
    - Fade in-** Press the start/stop button.
    - Fade out-** Press the start/stop button.
- If you're in PLAY (VCR) mode:**
- Fade in-** Press the ► (play) button.
  - Fade out-** Press the || (pause) button.

### Note:

- Faders cannot be selected when Card Mix is activated.

## Operating effects



Sound records/plays back normally.

When operating effects in CAMERA or CARD CAMERA mode, make sure the program selector is set to **P**.

CAMERA

PLAY (VCR)

CARD CAMERA

CARD PLAY (VCR)

Select effect

**1. Press the D.EFFECTS SELECT button to open the digital effects menu.**

- D.EFFECT **OFF**, FADER, EFFECT and MULTI-S appear.

**2. Select EFFECT.**

- The settings appear. Select the setting by turning the selector dial.

**3. Select the desired setting.**

- You return to the digital effects menu.

**4. Press the D.EFFECTS SELECT button to close the menu.**

- The menu disappears and the name of your selected setting flashes in the display.

Effect on/off

**5. If you're in PLAY (VCR) mode, press the ► (play) button.**

**6. Press the D.EFFECTS ON/OFF button.**

- The name of your selection stops flashing and takes effect on the display.
- Each time you press the D.EFFECTS ON/OFF button, the chosen effect is activated or deactivated.

CAMERA

PLAY (VCR)

CARD CAMERA

CARD PLAY (VCR)

**1. Press the D.EFFECTS SELECT button.**

- BLK&WHT flashes in the display.

**2. Press the D.EFFECTS ON/OFF button.**

- The effect is activated and the image appears in black and white.

## Using the Multi-Image Screen

Divides your display image into 4, 9 or 16 smaller images with the Image Capture feature. With this feature, the camcorder captures the current scene being shot or replayed. Choose the transition speed — manual, fast (every 4 frames), moderate (every 6 frames\*) or slow (every 8 frames\*) — at which to capture a moving subject, such as a person playing tennis or golf. Sound is recorded normally.

\* In Low Light mode: moderate (every 8 frames), slow (every 12 frames)

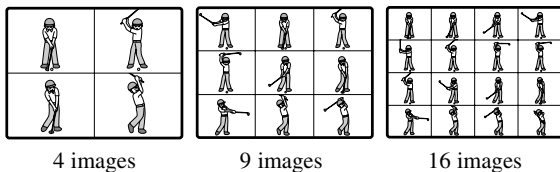

### Operating the multi-image screen



In PLAY (VCR) mode, you can only operate the multi-image screen in the following playback modes:

When M.S.SPEED is set to MANUAL: Still image playback, slow forward/reverse playback

When M.S.SPEED is set to FAST, MODERATE or SLOW: Still image playback

CAMERA \*

PLAY (VCR)

CARD CAMERA

CARD PLAY (VCR)

\* Make sure the program selector is set to  and any program other than the Night and Super Night recording program.

Select multi-image screen

- 1. Press the D.EFFECTS SELECT button to open the digital effects menu.**
  - D.EFFECT **OFF**, FADER, EFFECT and MULTI-S appear.
- 2. Select MULTI-S.**
  - M.S.SPEED and M.S.SPLIT settings appear.
- 3. Select M.S.SPEED.**
  - MANUAL, FAST, MODERATE and SLOW settings appear.
- 4. Select the desired setting.**
  - You return to the digital effects menu.
- 5. Select MULTI-S again.**
  - M.S.SPEED and M.S.SPLIT settings appear.
- 6. Select M.S.SPLIT.**
  - 4, 9, 16 settings appear.

**7. Select the desired setting.**

- You return to the digital effects menu.

**8. Press the D.EFFECTS SELECT button to close the menu.**

- The digital effects menu disappears.
- MULTI-S flashes in the display.

Multi-image screen on/off

**9. Press the D.EFFECTS ON/OFF button.**

- MULTI-S stops flashing.
- Manual: As you press the D.EFFECTS ON/OFF button, scenes will be captured one after another in the indicated number of times. If you push and hold the D.EFFECTS ON/OFF button for more than a second, the last image captured will be erased.
- The image currently being recorded is framed in blue. The frame disappears after the last image is captured.
- Automatic: The camcorder will capture the indicated number of images at the indicated speed.

**10. Press the start/stop button to begin recording.**

- The multi-image screen is recorded to the tape.

**Notes:**

- You can operate the multi-image screen from record or record pause mode.
- After all the images have been captured, press the D.EFFECTS ON/OFF button quickly to cancel the multi-image screen.
- If you are operating the multi-image screen in PLAY (VCR) mode and you stop or pause the tape, or press any other playback button or the date/photo search button, the multi-image screen will be cancelled.
- You cannot use digital zoom or the 16:9 mode when the multi-image screen is set. The display becomes “- - -”.
- The multi-image screen cannot be selected when Card Mix is activated.

## Audio Recording

### Selecting the audio mode



The camcorder can record sound in two audio modes — 16-bit and 12-bit. The 16-bit mode produces the higher sound quality (slightly superior to CD) while the 12-bit mode records on 2 channels (stereo 1), leaving 2 channels free (stereo 2) for you to add new sound at a later time.

CAMERA

PLAY (VCR)

CARD CAMERA

CARD PLAY (VCR)

**MENU**

( 39)

▶ VCR SET UP

▶▶ AUDIO MODE •• 12 bit

**To switch to the 16-bit mode, open the menu and select VCR SET UP. Then select AUDIO MODE, set it to “16 bit” and close the menu.**

- “16 bit” is shown in the display for approximately 4 seconds.



#### Notes:

- For details on adding new sound, see p. 96.
- For details of playing back a tape that has new sound on stereo 2, see p. 99.
- When you record to the MV6i MC from a camcorder with DV terminal outputs, the audio mode becomes automatically set to 12 bit.
- In PLAY (VCR) mode, the audio mode takes effect when doing analog line-in recording or AV insert. When you do DV in recording, the setting automatically changes to that of the digital device connected to the camcorder.

### External microphone

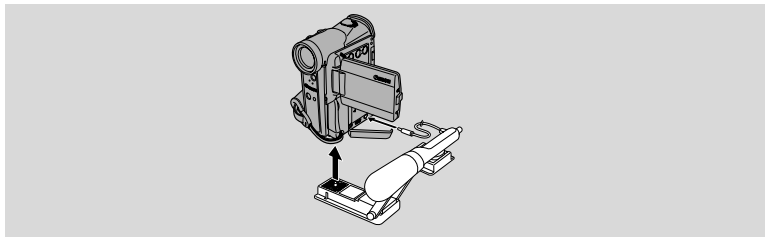

For greater creative control over audio recording, you can connect an external microphone to the camcorder via the MIC terminal. When using the MIC terminal, use a microphone with a built-in power supply (condenser microphone). It is possible to connect almost any stereo microphone with a plug diameter of 3.5 mm, however, their audio levels will be different from that of the built-in microphone. Attach the microphone to the optional SA-1 Adapter Bracket.

 **Note:**

- When using an external microphone, use a microphone cable not longer than 3 meters to avoid electromagnetic interference.

**Wind screen**

The camcorder has an automatic wind screen to prevent wind noise from interfering with the sound track. Make sure it's off when you want the microphone to be as sensitive as possible. Use the wind screen when recording in windy places such as the beach or near buildings.

CAMERA

PLAY (VCR)

CARD CAMERA

CARD PLAY (VCR)

**MENU**

( 39 )

▶ VCR SET UP

▶▶ WIND SCREEN • OFF

**To turn it on, open the menu and select VCR SET UP. Then select WIND SCREEN, set it to ON and close the menu.**

- WS  is shown in the display when you turn the wind screen on.

 **Notes:**

- Low sound may be reduced together with the wind noise. We recommend turning off the wind screen for normal recordings.
- The wind screen function cannot be turned on/off during recording.
- The wind screen can be used for audio dubbing with the built-in microphone in PLAY (VCR) mode as well as recording (when AUDIO DUB. is set to MIC. IN in VCR SET UP submenu).
- The wind screen does not operate when an external microphone is connected to the MIC terminal.

## Setting the Self-Timer

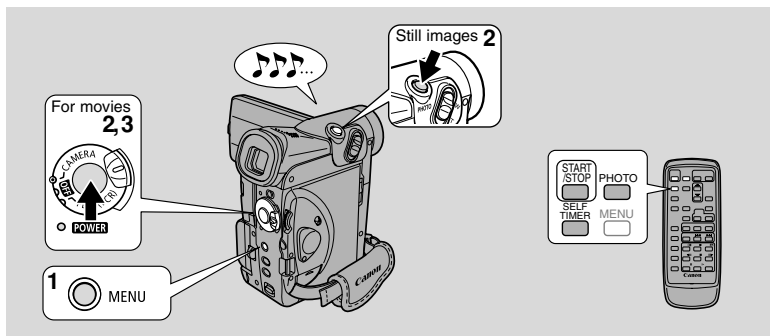
**E**

This is useful when you want to include yourself in the picture when recording movies or still images to a tape or memory card.

**CAMERA****PLAY (VCR)****CARD CAMERA****CARD PLAY (VCR)****MENU**

( 39 )

▶ CAM. SET UP

▶▶ SELF-TIMER •• OFF

### 1. Open the menu, select VCR SET UP and set the SELF-TIMER to ON

**or****press the SELF-TIMER button on the wireless controller.**

- SELF-T appears in the display.
- To have the subject monitor recording, rotate the LCD panel 180° ( 27).

For movies

### 2. Press the start/stop button.

- The camcorder starts to record after a 10-second countdown period (or after 2 seconds when you use the wireless controller). The time remaining counts down in the display (e.g. "5 SEC").
- SELF-T disappears from the display when recording begins.
- The tally lamp starts flashing.

### 3. Press the start/stop button to end recording.

For still images

### 2. Press the PHOTO button on the camcorder body or the wireless controller.

- The camcorder automatically adjusts the focus 2 seconds before the countdown is complete. The ● mark flashes white then turns green after the focus and exposure are set. If you are using the wireless controller, the ● mark starts flashing immediately after you press the PHOTO button.



- The camcorder takes the still image for approximately 6 seconds.
- If you're in CAMERA mode, the camcorder returns to record pause mode after recording to a tape. If you're in CARD CAMERA mode, the currently recording image appears after recording onto a memory card.

**Notes:**

- To cancel the self-timer setting, set the SELF-TIMER to OFF through the menu, or press the SELF-TIMER button on the wireless controller.
- To cancel the countdown of the self-timer, press the start/stop button (when recording a movie) or PHOTO button (when recording a still image).

## Adjusting AE Shift

**E**

By controlling the level of the automatic exposure (AE) function, you can lighten or darken the image slightly. This allows you to compensate for backlit, overexposed scenes.

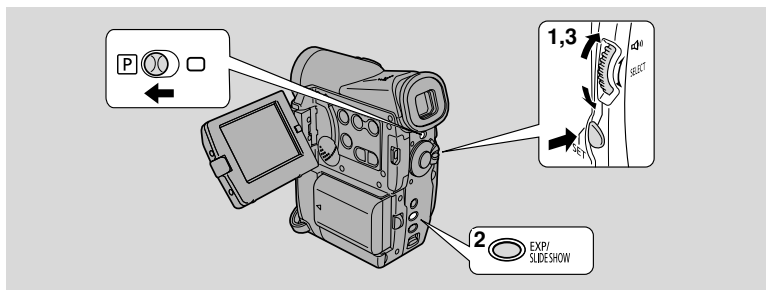

CAMERA

PLAY (VCR)

CARD CAMERA

CARD PLAY (VCR)

Make sure the program selector is set to **P**.

- 1. Press the SET button and select any recording program other than Spotlight, Sand & Snow, Night or Super Night from the program menu.**
- 2. Press the EXP button.**
  - ▶AE  $\pm 0$  appears light blue.
- 3. Turn the selector dial to choose your desired level.**
  - Levels are from  $-2$  to  $+2$ , in  $0.25$  intervals (excluding  $-1.75$  and  $+1.75$ ).
  - The higher the setting, the brighter the image.

### Notes:

- You cannot adjust the exposure without the ▶ mark before AE in the display. Press the EXP button so that ▶ appears before AE. Then you can adjust the exposure manually.
- You cannot adjust the AE Shift when the camcorder is set to  (Easy Recording), the Spotlight, Sand & Snow, Night or Super Night recording program.
- To cancel AE shift, set it to  $\pm 0$  and press the EXP button.

# Setting the Shutter Speed



Set the shutter speed manually to take stable shots of quickly moving subjects.

CAMERA

PLAY (VCR)

CARD CAMERA

CARD PLAY (VCR)

**MENU**

( 39)

▶CAM.SET UP

▶SHUTTER.....AUTO

1. Make sure the camcorder is set to the  (program AE) mode.
2. Press the SET button and choose AUTO from the program menu.
3. Open the menu and select CAM.SET UP.
4. Select SHUTTER.
5. Press the SET button to select the desired shutter speed.

TAPE

AUTO

1/50

1/120

1/250

1/500

1/1000

1/2000

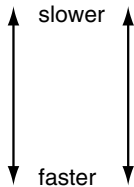

CARD

AUTO

1/50

1/120

1/250

- Only shutter speeds up to 1/250 are available when using a memory card.

6. Close the menu.

### Guidelines for shooting using high shutter speeds

- When shooting with a shutter speed of 1/1000 or higher, do not shoot the sun directly.

### Recommended shutter speeds when shooting:

- People doing outdoor sports such as golf or tennis



1/2000

- Moving cars or trains or other rapidly moving vehicles such as roller coasters



1/1000, 1/500 or  
1/250

- People doing indoor sports such as basketball



1/120

### Notes:

- You are unable to set the shutter speed in any recording program other than AUTO.
- The image may not appear smooth when a high shutter speed is set.
- The camcorder returns to the auto shutter setting when you slide the program selector to  (Easy Recording), or change the recording program.
- If you set the shutter speed to 1/500 or above in CAMERA mode and then switch the camcorder to CARD CAMERA mode, the shutter speed will automatically change to 1/250.

## Adjusting Focus Manually



E

The camcorder focuses automatically. All you have to do is point and the subject in the centre of the screen will usually be in sharp focus. It may happen that a subject is not suitable for autofocus. Use the manual focusing function to adjust the focus.

### 1. Press the FOCUS button to turn the autofocus off.

- The focus remains locked at the point set by autofocus.

### 2. Use the selector dial to set the focus.

- Turn the selector dial downward to move the focus farther away.
- Turn the selector dial upwards to bring the focus nearer.
- If you zoom in on your subject after turning off the autofocus, it may not stay in focus. It is generally best to adjust the zoom first and then the focus.



#### Notes:

- If the ► icon is shown before AE, the focus cannot be adjusted manually. Press the focus button again to bring the ► icon before MF.
- The camcorder will return to autofocus when selecting the □ (Easy Recording) program.
- Autofocus can not be turned off in □ (Easy Recording) program.
- See “Troubleshooting” on p. 154 for a list of subjects that may not be suitable for autofocus.

### Infinity Focus

Use this function when you wish to focus on faraway subjects such as mountains or fireworks.

### Press the FOCUS button more than 3 seconds in step 2 above to record in infinity focus mode.

- The MF $\infty$  icon will appear on the display.
- $\infty$  will disappear when you operate the zoom or the selector dial and the camcorder will change to manual focus.

## Setting the White Balance



The camcorder's auto white balance system compensates for a wide range of lighting conditions. Although slight variations are unavoidable, colours will appear natural in virtually every situation.

In some cases, you will get better results by setting the white balance yourself, or using one of the two preset modes:

- Indoor Mode
  - Under halogen or studio/video lighting
  - Subject is of one dominant colour
  - Close-ups
- Outdoor mode
  - In daylight, especially for close-ups and where the subject is of one dominant colour

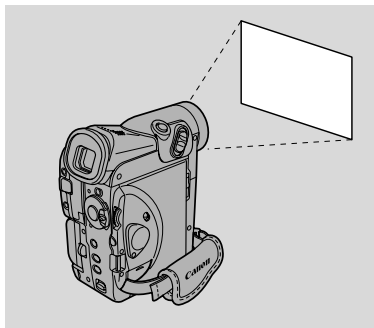

CAMERA

PLAY (VCR)

CARD CAMERA





CARD PLAY (VCR)

**MENU**

( [ ] 39)

▶ CAM.SET UP

▶ WHITE BAL...AUTO

1. Make sure the camcorder is set to the  (program AE) mode.
2. Open the menu and select CAM.SET UP.
3. Select WHITE BAL.
4. a) For the indoor, outdoor or auto settings, press the SET button to choose the setting.
  - / appears in the display when you set the white balance to indoor/outdoor mode.
- b) To set the white balance yourself, point the camcorder at a white object (such as a sheet of paper) and zoom in until it fills the display. Then press the SET button to select SET .
  - Make sure to continue pointing the camcorder at the white object until you have finished setting the white balance.
  - The  display flashes then remains lit.
  - Depending on the light source, the flashing may at times continue. The result will remain better than with the auto setting and you can continue recording.
5. Close the menu.

Setting the white balance manually will probably work better than auto white balance when shooting:

Subjects with one dominant colour, such as sky, sea or forest



Close-ups



In rapidly changing lighting conditions



In places lit by certain types of fluorescent or mercury vapour lights



#### Notes:

- Turn the digital zoom off (if necessary) to set a more accurate white balance.
- If you have set the white balance and lighting conditions change, reset the white balance.
- Try to record with light from a single source. Correct white balance cannot be obtained for two types of lighting at once.
- You cannot set the white balance or choose the indoor/outdoor mode when the program selector is set to the  (Easy Recording) program.
- The white balance returns to the AUTO setting when you slide the program selector to  (Easy Recording).
- When you turn the camcorder on, the white balance returns to AUTO. If you then switch the white balance to SET, the camcorder will remember your last setting.
- During normal outdoor shooting, setting to AUTO may provide better results.

## Enlarging the Image during Playback



You can enlarge the image by 2 times during PLAY (VCR) mode and CARD PLAY (VCR) mode. You can also move the image up, down, to the right or left.

- Movies played back from a memory card cannot be enlarged.

CAMERA

PLAY (VCR)

CARD CAMERA

CARD PLAY (VCR)

During Playback

### 1. Move the zoom lever toward T.

- The image is magnified by 2 times.

### 2. Move the image to the right and left.

- Turn the selector dial up to move the image to the left, down to move the image to the right.

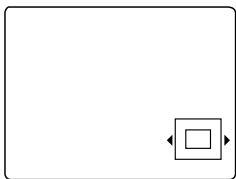

### 3. Move the image up and down.

- Press the SET button first. Turn the selector dial up to move the image up, and down to move the image down.
- Pressing the SET button will switch the direction between right and left, up and down.

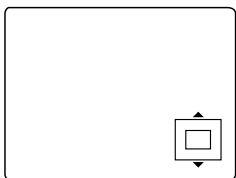

### 4. To cancel, move the zoom lever toward W.

## Displaying Date, Time and Camcorder Data (Data Code)



A data code, containing the date and time the recording was made and other camcorder data (shutter speed and exposure settings) is automatically recorded on a special data section of the tape.

- Only the date and time appear in the data code when using a memory card.

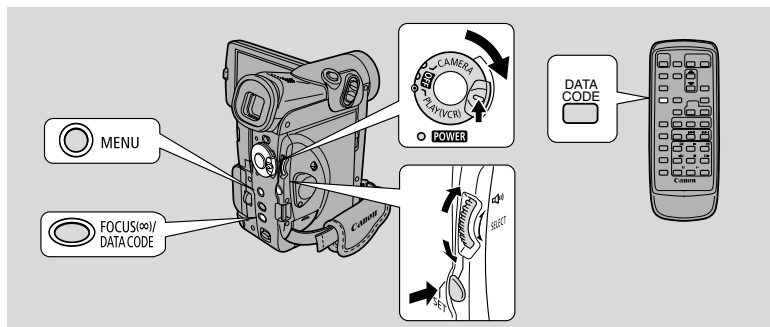

During PLAY (VCR) mode, the data code can be displayed or hidden while the camcorder is in play, slow or still mode.

Camcorder data may be displayed as “-- --” during fast forward, rewind, reverse playback, forward and reverse x2 playback.

**Press the DATA CODE button. When using a cassette, press it while the camcorder is in play, slow or still mode.**

- Press it once to display, once more to hide it.

### Selecting date/time



Select whether you want the date, the time, or both to show up on your data code display.

CAMERA

PLAY (VCR)

CARD CAMERA

CARD PLAY (VCR)

**MENU**

(□ 39)

▶ DISP. SET UP

▶▶ D/TIME SEL. • DATE & TIME

**To change the date and time combination, open the menu and select DISP.SET UP. Then select D/TIME SEL., set it to DATE, TIME or DATE & TIME and close the menu.**

## Setting the data code



E

You can also choose to display camcorder data (shutter speed and exposure settings) in the data code.

CAMERA

PLAY (VCR)

CARD CAMERA

CARD PLAY (VCR)

**MENU**

( 39)

▶ DISP.SET UP

▶▶ DATA CODE...DATE/TIME

**To change, open the menu and select DISP.SET UP. Then select DATA CODE, set it to DATE/TIME, CAMERA DATA or CAM. & D/T and close the menu.**

Possible data code combinations for tapes:

| DATA CODE<br>(tape only)<br>D/TIME SEL. | Date/Time                | Camera data   | Date/Time &<br>Camera data                |
|---|--------------------------|---------------|---|
| Date                                    | 1. JAN. 2003             | F1.8<br>1/250 | F1.8<br>1/250<br>1. JAN. 2003             |
| Time                                    | 12:00:00 PM              | F1.8<br>1/250 | F1.8<br>1/250<br>12:00:00 PM              |
| Date & Time                             | 12:00 PM<br>1. JAN. 2003 | F1.8<br>1/250 | F1.8<br>1/250<br>12:00 PM<br>1. JAN. 2003 |



### Notes:

- The data code will read “-- --” in the following situations:
  - During playback of a blank section of tape.
  - If the tape was recorded before entering the date and time in the camcorder’s memory.
  - If the tape was recorded on a camcorder without a data code function.
  - If noise or tape damage prevents the data code from being read.
- If a recording made on MV6i MC is played back on a different DV camcorder, the data code may not be displayed correctly.
- The data code will appear in the display even if DISPLAYS ( 160) has been set to OFF through the menu.

## Six-second auto date



The 6-second auto date appears for 6 seconds to mark the changeover of a day if the tape was being recorded at 12:00 midnight. It also appears for 6 seconds when you start playback and have the data code turned off. The 6-second auto date will adjust for any time zone changes you have indicated.

CAMERA

PLAY (VCR)

CARD CAMERA

CARD PLAY (VCR)

### MENU

( 39)

▶ DISP. SET UP



▶ 6SEC. DATE...OFF

**To turn the 6-second auto date on, open the menu and select DISP.SET UP. Then select 6SEC. DATE, set it to ON and close the menu.**



#### Note:

- When 6SEC.DATE is turned on but DISPLAYS ( 160) is turned off, the 6-second auto date will still appear for 6 seconds.

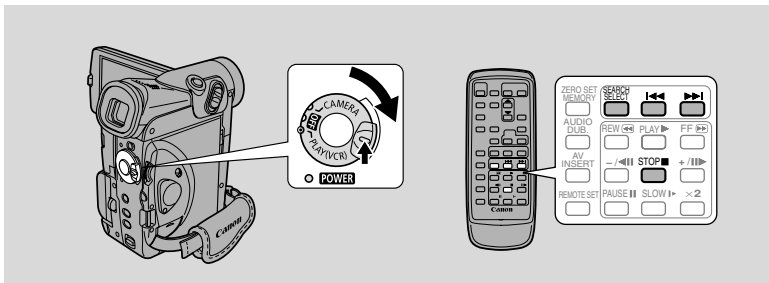

This allows you to move quickly through still images recorded anywhere on a tape (photo search) or between different days or areas of recording (date search) on a tape.

CAMERA

PLAY (VCR)

CARD CAMERA

CARD PLAY (VCR)

## 1. Press the **SEARCH SELECT** button to choose between photo/date search.

- PHOTO SEARCH or DATE SEARCH is shown in the display for 4 seconds.

## 2. Press the **◀◀** and **▶▶** buttons to move backwards or forwards through the still images or between different days of recording.

- Press once to move to the start of the previous/next still image or day on the tape.
- You can press more than once to move to the corresponding still image or day (up to a maximum of 10 times), e.g. press the **▶▶** button 5 times to move forward 5 still images or days.
- PHOTO SEARCH/DATE SEARCH appears in the middle of the display alongside the **◀◀** or **▶▶** mark and number to search through. You can change direction easily by pressing the button for the opposite direction.



### Notes:

- Press **■** (stop) to stop mid-search.
- If you begin a search very close to the start of a recorded still image during photo search, the camcorder may skip straight past it.
- When you have set the area for the World Clock, date search also looks for the change in date based on the adjusted time.
- A date/area cannot be identified if the total recording time on that day/area was less than 1 minute.
- Date search playback may start just before or after the beginning of the located section.
- If the data code is not displayed correctly you will not be able to operate the date search correctly.

## Returning to a Pre-Marked Position

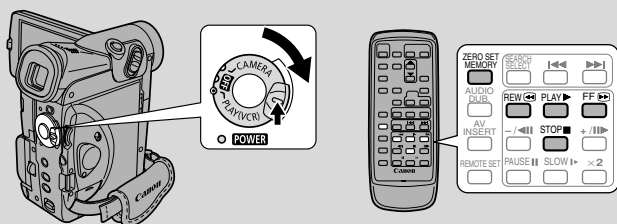

Use the wireless controller to mark a point on a tape that you want to return to following playback.

CAMERA

PLAY (VCR)

CARD CAMERA

CARD PLAY (VCR)

- 1. Press the ZERO SET MEMORY button on the wireless controller during playback at a point you want to return to later.**
  - The time code is replaced by a tape counter that is set to zero with the **M** indication.
  - Press the ZERO SET MEMORY button once more to cancel the zero set memory.
- 2. When you have finished playback, fast forward or rewind the tape. The tape stops automatically when it reaches the zero set position.**
  - **RTN▶▶** or **◀◀RTN** appears in the display.
  - The tape counter with **M** indication disappears from the display and the time code reappears.



### Notes:

- Time code and tape counter display may not match accurately.
- The zero set memory may not function correctly where there is a break between recordings on the tape.
- You can also use zero set memory to mark a position on a tape in CAMERA mode. When you then play back the tape, pressing rewind will take you back to the pre-marked position.
- If you remove the tape while the zero set memory is set, the memory is cancelled and the tape counter reverts to time code.
- The camcorder remembers your setting even if you turn it off and back on again or move the program selector.

## Editing to a VCR

By connecting the camcorder to a VCR, you can edit your recordings in order to remove unwanted scenes — or combine different shots to create your own video productions.

### Preparations

- 1. Connect the camcorder to the VCR.**
  - See “Connections for Playback on a TV Screen” on p. 32.
- 2. Prepare the TV and VCR.**
  - Turn on the TV and set the TV/VIDEO selector to VIDEO.
  - Turn on the VCR, and set its input selector to LINE. Load a blank cassette, and put the VCR in record pause mode.
  - See your TV and VCR instruction manuals for details.
- 3. Turn the camcorder’s POWER switch to PLAY (VCR), and move the camcorder’s TAPE/CARD switch to TAPE.**
  - Make sure the AV/headphone terminal is set to AV through the menu ( 32). If PHONES appears in the display, switch the terminal.
- 4. Load your recorded cassette.**

### Editing



- 1. Find a point on your recorded cassette slightly before the section you want to copy.**
- 2. Start to play it back while you monitor the picture on the TV.**
- 3. Start recording on the VCR as soon as the section you want to copy appears on the screen.**
- 4. Pause the VCR at the end of the section you want to copy, then stop playback on the camcorder.**
- 5. Repeat steps 1 to 4 until your edited recording is complete.**



#### Note:

- The quality of the edited tape will be slightly lower than that of the original.

### Ⓛ (LANC) terminal

The Ⓛ terminal allows you to connect the camcorder to equipment. Some buttons on editing equipment may operate differently from those on the camcorder.

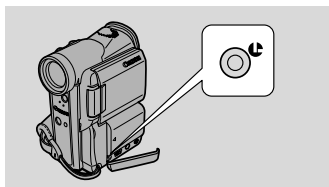

#### Notes:

- Ⓛ (LANC) is a trademark. It stands for Local Application Control Bus System.
- We cannot guarantee the results when connecting to equipment not bearing the LANC Ⓛ symbol.

## Dubbing to/from a Tape with Digital Video Equipment

E

Digital video equipment fitted with the DV terminal lets you edit, copy and transfer data digitally, with virtually no generation loss in image and sound quality. The DV terminal is for both line-in and line-out, since a single DV cable can handle data in both directions.

- If a digital VCR is connected and an anomalous signal is sent from the VCR, the images recorded on the tape may also be anomalous (although it may not appear so on the TV image), or not recorded at all.
- You are unable to dub tapes recorded with the copyright protective signal.

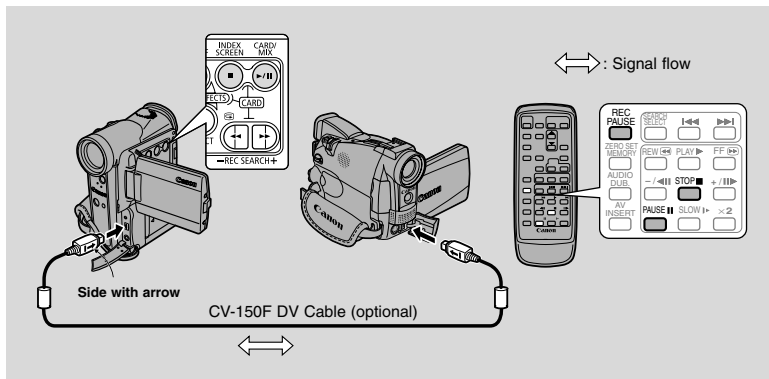

Editing

### Preparations

Example dubbing to the camcorder

- 1. Connect the camcorder and the other digital device.**
  - Connect the Canon CV-150F DV cable (optional) with the sides of the plugs marked with the arrows facing as shown above.
- 2. Prepare the other device.**
  - Turn on the power and load a recorded cassette.
- 3. Turn the camcorder's POWER switch to PLAY (VCR), and move the camcorder's TAPE/CARD switch to TAPE.**
  - DV IN appears in the display.
- 4. Load a blank cassette.**



- 1. Find a point on your recorded tape slightly before the section you want to copy and set it to playback pause mode.**
- 2. Press the REC PAUSE button on the wireless controller.**
  - The camcorder enters record pause mode.
- 3. Start playback on the other digital device while you monitor the picture.**
- 4. Press the pause button.**
  - Recording starts.
- 5. When you get to the point where you want to stop recording, press the stop button or the pause button.**
  - Recording stops.
- 6. Stop playback on the other device.**



### Notes:

- Blanks between recordings on the playback tape are recorded as anomalous images on the tape that is being recorded to.
- When dubbing to a cassette with digital video equipment, be sure to set AV → DV OUT to OFF in the menu (□□92).

## Concerning copyrighting

### Copyright precaution

Certain pre-recorded video tapes, films and other materials, as well as some television programmes are copyrighted. Unauthorized recording of these materials may violate copyright protection laws.

### Copyright signals

When playing back:

If you try to play back a tape that contains copyright control signals for the protection of software, “COPYRIGHT PROTECTED PLAYBACK IS RESTRICTED” appears in the display for a few seconds and then the camcorder displays a blank blue screen; you cannot view the contents of the tape.

When recording:

If you try to record from software that contains copyright control signals for the protection of software, “COPYRIGHT PROTECTED DUBBING RESTRICTED” appears in the display; you cannot record the contents of the software. You cannot record copyright protection signals to a tape using this camcorder.

## Recording from a VCR, TV or Analog Camcorder (Analog Line-in)

E

You can record a video played on your VCR or analog camcorder (for digital camcorders, see p. 86) or a TV program onto a tape in the MV6i MC, if the TV or other device has audio/video outputs.

- If an anomalous signal is sent from the TV or VCR, the images recorded on the tape may also be anomalous (although it may not appear so on the TV image), not recorded at all, or COPYRIGHT PROTECTED DUBBING RESTRICTED may appear in the display.
- You are unable to dub tapes recorded with the copyright protective signal.
- For higher picture quality, we recommend using the S-150 S-video cable when doing analog line-in recording.
- When connecting to a TV/video with SCART terminal, use a SCART adapter with input capability (commercially available). The SCART Adapter PC-A10 is for output only.

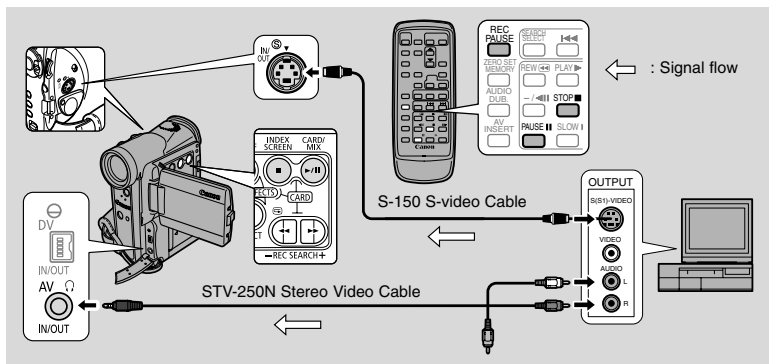

You cannot use headphones while doing analog line-in recording. If you have the AV/headphones terminal set to headphones, it will automatically switch to AV for analog line-in recording. PHONES disappears from the display.

### Preparations

Example recording from a VCR

1. **Connect the camcorder to the VCR.**
2. **Prepare the device.**
  - Set the TV/Video selector on the television to Video. For further details, see “Connections for Playback on a TV Screen” on p. 32.
  - Turn on the VCR. Load your recorded cassette, and put the VCR in playback pause mode.
  - See your TV and VCR instruction manuals for details.
3. **Turn the camcorder’s POWER switch to PLAY (VCR), and move the camcorder’s TAPE/CARD switch to TAPE.**
4. **Load a blank cassette.**



1. Find a point on your recorded tape slightly before the section you want to copy and set it to playback pause mode.
2. Press the REC PAUSE button on the wireless controller.
  - S-video and AV IN/OUT terminals work as input terminals.
  - The camcorder enters record pause mode.
3. Start playback on the other device or turn on the TV to see the desired program while you monitor the picture.
4. Press the pause button.
  - Recording starts.
5. When you get to the point where you want to stop recording, press the stop button or the pause button.
  - Recording stops.
6. Stop playback on the other device.

**Note:**

- You can monitor the picture in the viewfinder or LCD screen.

## Digitally Outputting Analog Video and Audio Signals (Analog-Digital Converter)

Connecting the camcorder to your VCR or 8 mm video camera allows conversion of recorded analog video and audio signals to digital signals in an instant. The digital signals can be output to the other equipment with a DV terminal. The camcorder's DV terminal works exclusively as an output terminal.

- There may be cases where analog-digital conversion cannot be done properly, depending on the signals output from the connected equipment.  
For example: Signals that include the copyright protective signal, or anomalous signals such as ones that include ghost signals, etc.
- You cannot use your headphones during digital conversion. Even if the AV/headphone terminal is set to "PHONES" through the menu, it will automatically be set to "AV", and "PHONES" will disappear from the display.
- You are recommended to use power from a household power socket with the power adapter.
- Do not operate with a cassette inserted to the camcorder.
- Turn off the power of all equipment before performing connections.
- Refer also to the instruction manuals of the other equipment connected.
- When connecting to a TV/video with SCART terminal, use a SCART adapter with input capability (commercially available). The SCART Adapter PC-A10 is for output only.

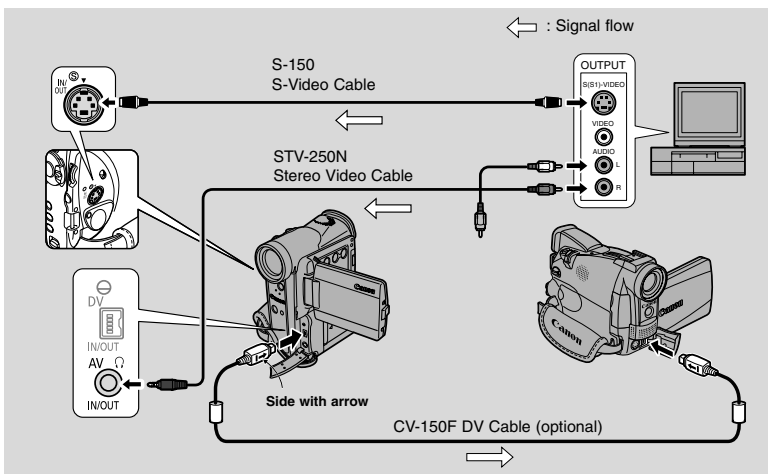

Above illustration shows the connection using a S-video cable. You can also connect to the VIDEO terminal instead ( 35).

## Turning the analog-digital converter on

CAMERA

PLAY (VCR)

CARD CAMERA

CARD PLAY (VCR)

### MENU

( 39)

▶ VCR . SET UP

▶▶ AV → DV OUT...OFF

To turn the analog-digital converter on, open the menu and select VCR SET UP. Then select AV → DV OUT, set it to ON and close the menu.

#### Cautions:

- For normal use, set AV → DV OUT to OFF through the menu. If it is set to ON, you cannot input digital signals through the camcorder's DV terminal.
- When connecting to a PC equipped with a DV terminal, you may not be able to transfer converted signals to your PC, depending on the software you are using, and the specifications of your PC and its settings.

## Recording Over Existing Scenes (AV Insert Editing)

You can insert and replace images/audio on the tape of the camcorder with images/audio from other video devices connected via AV terminal or DV terminal. Original video and audio will be replaced with the new video and audio.

E

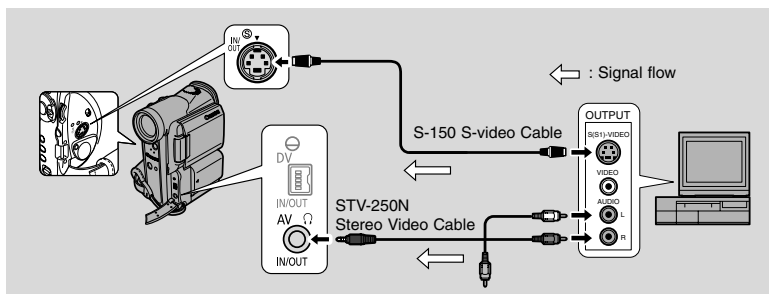
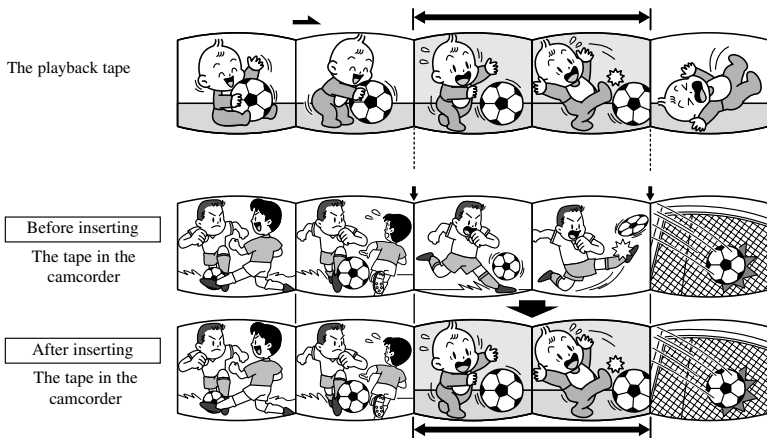

Editing

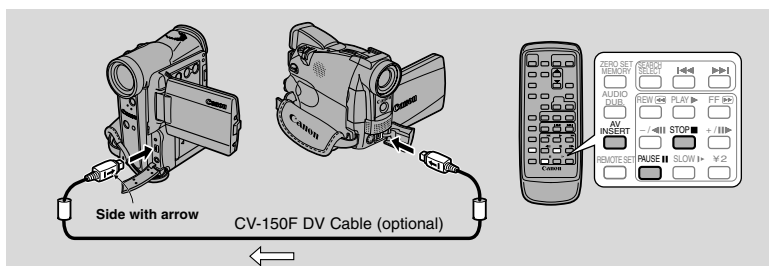

## Preparations

### The tape in the MV6i MC:

When using the MV6i MC's AV insert function, only record to tapes recorded in SP mode.

If there are non-recorded portions or portions recorded in LP mode on the tape, recording will stop.

### The playback tape:

Use only tapes without non-recorded portions.

If there are non-recorded portions or changes in the recording mode, you may not be able to insert AV correctly.

You cannot insert AV in the following cases:

- The playback tape has been poorly recorded.
- During special playback: fast forward playback, rewind playback or slow playback etc. (analog only).

### TV:

You cannot insert AV from a TV program with anomalous synchronized signals, such as when the program itself received poor signals.

#### Example recording from a VCR

#### 1. Connect the camcorder to the VCR.

#### 2. Prepare the VCR and TV.

- Set the TV/Video selector on the television to Video. For further details, see "Connections for Playback on a TV Screen" on p. 32.
- Turn on the VCR and load a recorded cassette.
- See TV and VCR instruction manuals for details.

#### 3. Turn the camcorder's POWER switch to PLAY (VCR) and load a recorded cassette.

- Make sure the REC/SAVE tab on the cassette has been slid to REC (closed position).

#### 4. Move the camcorder's TAPE/CARD switch to TAPE.



1. On the VCR, locate a point 3 seconds before the scene to be inserted. Set the VCR to playback pause mode.
2. On the camcorder, press **PLAY** and locate the recording start point. Set the camcorder to playback pause mode.
  - You can use the playback buttons on the body of the camcorder or the special playback functions on the wireless controller in the same way as in playback mode.
3. Press the **AV INSERT** button.
  - AV INSERT and ●■■ appear in the display.
4. Play back the tape in the VCR.
5. To start inserting, press the **PAUSE** button on the camcorder.
  - ●■■ changes to ●.
6. To stop inserting, press the **STOP** button on the camcorder.
  - Inserting stops and AV INSERT disappears from the display. The camcorder returns to stop mode.
  - If instead of pressing STOP you press PAUSE, the camcorder returns to the AV insert pause mode.
  - If you set the zero set memory at the position on the tape where you want to stop inserting, every time you return to that point, the camcorder will cancel its AV inserting and enter stop mode.
7. Stop playback on the VCR.

## Audio Dubbing

E

You can add sound to the original sound on a pre-recorded tape from audio products (AUDIO IN) or with the internal or external microphone (MIC. IN). The original sound will not be erased. For best results, add sound to tapes that have been recorded with this camcorder in SP mode with 12-bit sound. If there are non-recorded portions on the tape, or portions recorded in a mode other than SP mode, or with 16-bit or 12-bit, 4-channel sound, dubbing will stop. If your tape hasn't been recorded in SP mode with 12-bit sound, we recommend dubbing your original tape onto a blank tape using the MV6i MC's analog line-in function, then dubbing audio onto the new tape. Make absolutely sure to set the audio mode of the new tape to 12-bit and the recording mode to SP.

### To connect other audio equipment:

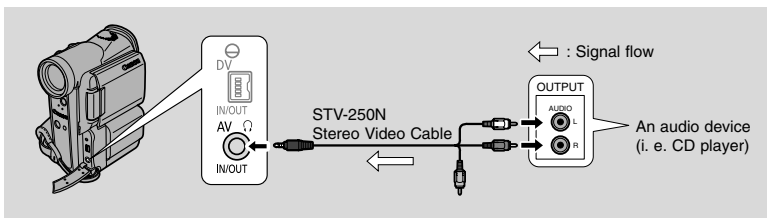



### Notes:

- Do not use the yellow video terminal.
- The AV terminal doesn't put out any video, so connect the S-video terminals and check your TV, or check the LCD or the viewfinder as you add new sound. Always check the new sound with the speaker.

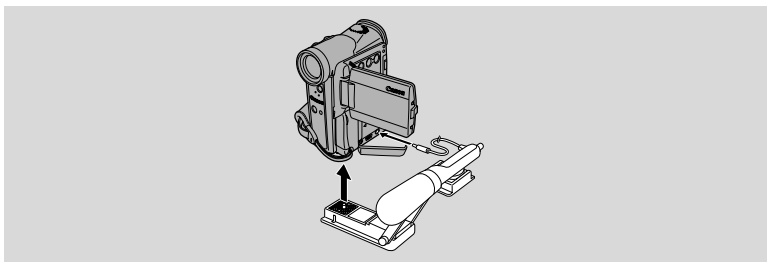
### To connect an external microphone:



## Notes:

- When you add sound using the built-in microphone make sure not to connect any cables to the MIC terminal.
- To use your TV to monitor video, connect the S-video terminal (  34) or the AV terminal (use only the video plug) to your TV. You can monitor the sound with headphones only when using the S-video terminal (  32).

## Preparations

Turn the camcorder's POWER switch to PLAY (VCR), and move the camcorder's TAPE/CARD switch to TAPE. Load a recorded cassette.

- Make sure the REC/SAVE tab on the cassette has been slid to REC (closed position).

## Dubbing

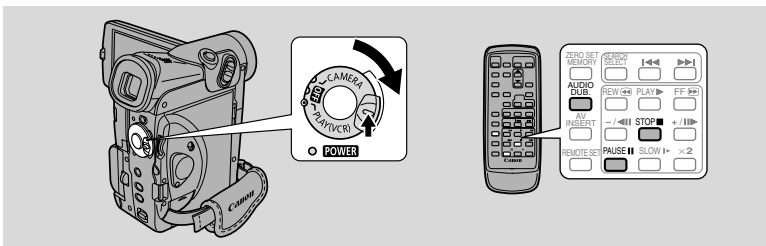

Do not connect/disconnect any cables to/from the camcorder when dubbing audio or preparing to dub audio.

CAMERA

PLAY (VCR)

CARD CAMERA

CARD PLAY (VCR)

## MENU

(  39)

▶ VCR SET UP



▶▶ AUDIO DUB...AUDIO IN

1. Open the menu and select **VCR SET UP**.
2. Select **AUDIO DUB**.
3. Select **AUDIO IN** or **MIC. IN** and close the menu.
4. Locate the point where you want to start audio dubbing, then press the **PAUSE** button.
  - You can use the playback buttons on the body of the camcorder or the special playback functions on the wireless controller in the same way as in playback mode.
  - The camcorder becomes set to playback pause mode.

**5. Press the AUDIO DUB. button.**

- AUDIO DUB. and  appear on the display.

**6. Press the PAUSE button (and start play on the other audio device if AUDIO IN).**

- Audio dubbing starts.
- Direct your voice into the microphone.
-  changes to .

**7. When you get to the point where you want to stop dubbing, press the STOP button (and then stop play on the other audio device if AUDIO IN).**

- Audio dubbing stops and AUDIO DUB. disappears from the display.
- The camcorder returns to stop mode.
- You can also set zero set memory ( 84) at the place you want to stop audio dubbing, then every time you return to that position, audio dubbing will stop.
- If instead of pressing STOP you press PAUSE, the camcorder will return to the playback pause mode.

**Notes:**

- You cannot use the DV terminal while adding sound.
- You might want to adjust the audio mix ( 99) when playing back a tape with added sound.
- There may be a loss of sound quality if you add sound to a tape recorded on a camcorder other than the MV6i MC.
- After adding sound 3 or more times to the same place on a tape, there may be some loss in sound quality.

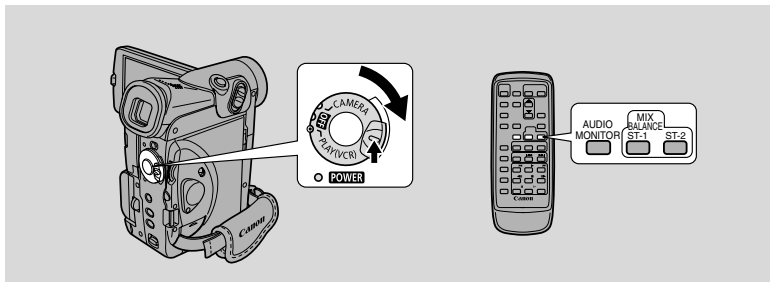

When you play back a tape that was recorded in 12-bit mode, you can set the audio output to play: stereo 1 (the original sound), stereo 2 (any new sound, dubbed to the tape after recording), or mix the balance between the two.

- Audio from the 16-bit mode only contains stereo 1 sound and so you cannot/do not need to select the audio mix. The same is true for the 12-bit stereo 1 mode, unless new sound has been added post-recording.

CAMERA

PLAY (VCR)

CARD CAMERA

CARD PLAY (VCR)

## 1. Choose the output.

- Press AUDIO MONITOR on the wireless controller.
- Starting with the last selected setting, 4 settings appear as you push the button:
  - STEREO1 for just stereo 1.
  - STEREO2 for just stereo 2.
  - MIX/FIXED for an equal mix of stereo 1 and 2.
  - MIX/VARI. (mix variable) for when you want to mix the balance between stereo 1 and 2.
- To simply choose STEREO1, STEREO2 or MIX/FIXED, make sure your choice appears on the display.
- If you choose MIX/VARI., you can go on to mix the balance.
- Use the ST-1/ST-2 keys to mix the balance. A bar showing the mix appears on the screen for 4 seconds.



### Note:

- When you have chosen the output, STEREO1, STEREO2, MIX/FIXED or MIX/VARI. is shown in the top left of the display for a few seconds. If you turn the power off the output is set to STEREO1.

## Selecting audio output channels



When you play back a tape whose audio has been recorded on multiple channels, you can change the output channels of that sound.

CAMERA

PLAY (VCR)

CARD CAMERA

CARD PLAY (VCR)

### MENU

( 39)

▶ VCR SET UP



▶ OUTPUT CH...L/R

1. Load a tape recorded with multiple-channel audio.
2. Open the menu and select VCR SET UP. Then select OUTPUT CH, set it to the desired setting and close the menu.
  - Refer to the following list.

| OUTPUT CH setting | Playback sound                  |                                    |
|-------------------|---------------------------------|------------------------------------|
|                   | Tape recorded with stereo sound | Tape recorded on multiple channels |
| L/R               | L+R channels                    | main + sub                         |
| L/L               | L channel only                  | main only                          |
| R/R               | R channel only                  | sub only                           |

## Connecting to a Computer Using a DV (IEEE1394) Cable

E

You can transfer recordings to a computer equipped with a DV (IEEE1394) terminal or IEEE1394 capture board (optional software required). Use the optional CV-150F (4 pin–4 pin) or CV-250F (4 pin– 6 pin) DV Cable.

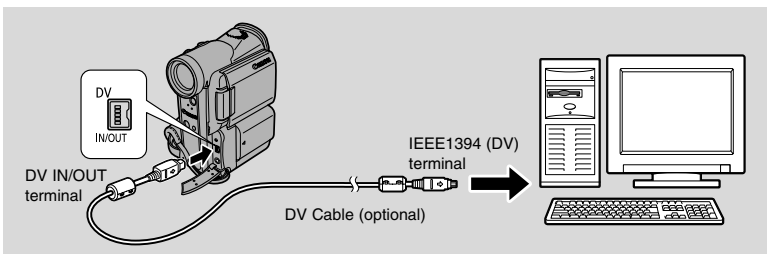

### Cautions:

- Do not disconnect the DV cable, or turn off the camcorder or computer while data is being transferred to the computer.
- Operation may not work correctly depending on the software and the specifications/settings of your computer.

### Notes:

- We recommend powering the camcorder from a household power source while it is connected to the computer.
- Refer also to the instruction manual of the computer.
- Optional software required. Refer also to the instruction manual of the software.
- For transferring recordings from a memory card to the computer using a USB cable, see p. 141.

## DV NETWORK SOLUTION DISK (Windows XP Users)

Windows XP users can use the software on the supplied DV NETWORK SOLUTION DISK to perform videoconference and file transfer over the Internet, or upload files from the computer to the memory card and use the camcorder as card reader/writer. The available functions depend upon the camcorder model and the networking environment. For details, refer to the DV NETWORK SOLUTION DISK Software Instruction Manual.

### Cautions:

- Do not disconnect the DV cable, remove the memory card or turn off the camcorder or computer while data is being transferred to the computer (while the camcorder's card access indicator is flashing). Doing so may damage the memory card's data.
- The image files on your memory card and the image files saved on the hard disk drive of your computer are your valuable, original data files. If you wish to use image files on your computer, be sure to make copies of them first, retaining the original.

## Inserting and Removing the Memory Card



You can use **SD** SD Memory Cards or a commercially available MultiMediaCards with this camcorder. The SD Memory Card has a protect switch for prevent accidental erasure.

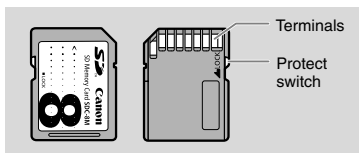

### Cautions:

- This camcorder is compatible with SD Memory Cards or MultiMediaCards only. Do not use any other types of memory cards.
- Turn off the camcorder before inserting or removing the memory card. Otherwise it may result in data damage.
- Do not touch the memory card terminals.
- If you use memory cards other than the supplied one, make sure to format them with the camcorder ( 140).
- For instructions on how to connect the camcorder to the computer, see Connecting to a Computer using a USB Cable ( 141).

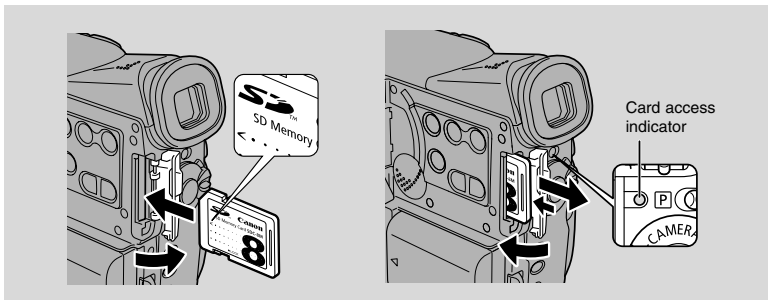

### Inserting the Card

1. Turn off the camcorder.
2. Open the cover.
3. Insert the memory card all the way into the memory card slot.
4. Close the cover.
  - Do not close the cover forcefully without having the card correctly inserted.

### Removing the Card

Do not forcefully remove the memory card without first pushing it in.

1. Turn off the camcorder.
  - Make sure that the card access indicator is not flashing.
2. Open the cover.
3. Push the memory card to release it. Remove the memory card.
4. Close the cover.

## Selecting the Image Quality/Size

### Selecting the Still Image Quality

**E**

Still image Quality: Superfine, Fine, Normal

CAMERA

PLAY (VCR)

CARD CAMERA

CARD PLAY (VCR)

**MENU**

( 39)

▶ CARD SET UP

▶▶ SI QUALITY •• FINE

To change the image quality, open the menu and select **CARD SET UP**. Then select **SI QUALITY**, set it to **FINE** or **NORMAL**, and close the menu.

- The image quality may not differ between the settings depending on the still image.

### Selecting the Image Size of Still Images and Movies



Image Size: Still image: 1024 × 768 pixels/640 × 480 pixels

Movie: 320 × 240 pixels/160 × 120 pixels

Still Image

CAMERA

PLAY (VCR)

CARD CAMERA

CARD PLAY (VCR)

**MENU**

( 39)

▶ CARD SET UP

▶▶ SI SIZE •• 1024×768

To change the image size of a still image, open the menu and select **CARD SET UP**. Then select **SI SIZE**, set it to “640 × 480” and close the menu.

- “640” appears in the display.

Movie

CAMERA

PLAY (VCR)

CARD CAMERA

CARD PLAY (VCR)

**MENU**

( 39)

▶ CARD SET UP

▶▶ MOVIE SIZE •• 320×240

To change the image size of a movie, open the menu and select **CARD SET UP**. Then select **MOVIE SIZE**, set it to “160 × 120” and close the menu.

- “160” appears in the display.

## Maximum Number of Still Images on an 8 MB Memory Card and Their File Sizes

| Image Size<br>Image Quality | 1024 × 768        |                     | 640 × 480         |                     |
|-----------------------------|-------------------|---------------------|-------------------|---------------------|
|                             | No of Images      | File Size per Image | No of Images      | File Size per Image |
| Superfine                   | Approx. 14 images | 440 KB              | Approx. 35 images | 175 KB              |
| Fine                        | Approx. 20 images | 300 KB              | Approx. 52 images | 120 KB              |
| Normal                      | Approx. 39 images | 160 KB              | Approx. 86 images | 65 KB               |

\* The actual number varies on the shooting conditions and subjects. Sample images already recorded on the supplied SD Memory Card are to be included in the total number.

### Maximum continuous recording time

| Image Size | Max. Continuous Recording Time | Total File Size | File Size per Second |
|------------|--------------------------------|-----------------|----------------------|
| 320 × 240  | 10 seconds                     | 1.4 MB          | 140 KB/sec           |
| 160 × 120  | 30 seconds                     | 2.3 MB          | 77 KB/sec            |



#### Notes:

- Still images recorded in 1024 × 768 pixels may not be displayed correctly in a camcorder not supporting this size.
- The remaining image capacity indicates the number of still images, even when movies are recorded.
- Still images are compressed and recorded in the JPEG (Joint Photographic Experts Group) format, and movies in the Motion JPEG format.
- The remaining number of images that can be recorded on the memory card may sometimes decrease by 2 images at once.

### Card access display



The operating states of the memory card are shown in the middle of the display.

CAMERA

PLAY (VCR)

CARD CAMERA

CARD PLAY (VCR)

**MENU**

( 39 )

▶ DISP. SET UP

▶▶ CARD ACCESS-ON

**To turn the card access display off, open the menu and select DISP. SET UP. Then select CARD ACCESS, set it to OFF and close the menu.**

## File numbers

**E**

The Still images/movies you take are automatically assigned file numbers from 0101-9900 and stored in folders of 100 images each. Each folder is numbered from 101 to 998 and recorded on the memory card. Sample images have been pre-recorded on the supplied SD Memory Card, entering folder number 100 (folder name is “100canon”).

Set the image file numbers so that they reset each time a new memory card is inserted, or so that they count up continuously.

### 1 CONTINUOUS

Numbering is continuous between cards, so that the first file number assigned on a new memory card is 1 more than the last file number assigned on the previous memory card. When the file numbers are set to CONTINUOUS, each image taken is assigned a different number, avoiding duplication of numbers. This is convenient when you want to manage your images on a PC. We recommend keeping the file numbers set to CONTINUOUS.

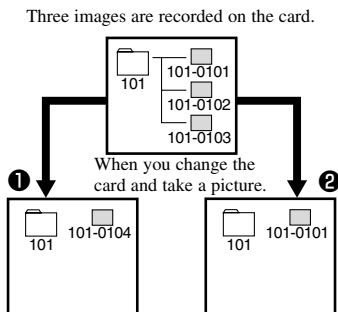

### 2 RESET

Each time you insert a new memory card, the file number resets to its default value (101-0101). If the card already contains files, the next available number is assigned.

CAMERA

PLAY (VCR)

CARD CAMERA

CARD PLAY (VCR)

**MENU**

( 39 )

▶ CARD SET UP

▶ FILE NOS. . . . CONTINUOUS

**To change the file numbering, open the menu and select CARD SET UP. Then select FILE NOS., set it to RESET and close the menu.**



## Turning off the shutter sound



Makes the sound of a shutter being released when a still image is recorded to a memory card.

CAMERA

PLAY (VCR)

CARD CAMERA

CARD PLAY (VCR)

**MENU**

( 39)

▶CARD SET UP

▶▶SHTR SOUND••ON

**To turn the shutter sound off, open the menu and select CARD SET UP. Then select SHTR SOUND, set it to OFF and close the menu.**

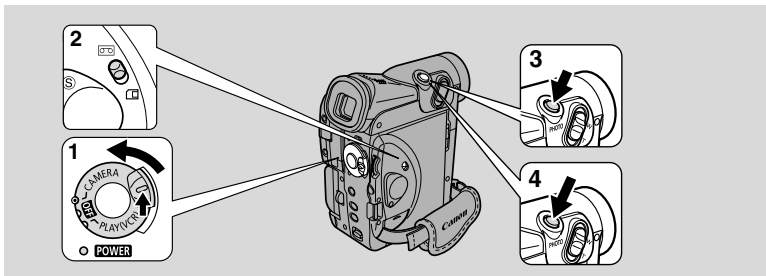

You can record still images onto a memory card. In addition to the still images you record directly onto the memory card, you can record images from a tape in the camcorder, or images input via the DV terminal or AV terminal onto the memory card.

### Cautions:

- When you are using an SD Memory Card, make sure the protect switch is set to allow recording.
- While the card access indicator flashes, do not turn off the camcorder, disconnect the power source or remove the memory card. Doing so could result in data damage.



### Note:

- Make sure a memory card with enough memory available is inserted into the camcorder.

## Recording with the Camcorder

CAMERA

PLAY (VCR)

**CARD CAMERA**

CARD PLAY (VCR)

- 1. Press and hold the small button on the POWER switch and turn the POWER switch to CAMERA.**
- 2. Move the TAPE/CARD switch to CARD.**
  - The number of images that can still be recorded on the memory card, and other information appear in the display.
  - The camcorder will turn itself off if you are using a battery and do not operate the camcorder for more than 5 minutes. Set the POWER switch to OFF and then back to CAMERA.
- 3. Press the PHOTO button halfway and hold it.**
  - Exposure is locked.
  - During autofocus  flashes white in the display as the camcorder adjust the focus and it is displayed continuously as a green mark when the camcorder is ready to take the still image.

#### 4. Press the PHOTO button fully down to record the still image.

- ● disappears from the display. The shutter sound sounds and simultaneously the display appears to close for an instant as if it were a shutter releasing.
- The card access indicator flashes and the card access display appears in the display (See “The indicators that appear in the LCD display when LCD MIRROR is turned on” on page 27).

#### Notes:

- To use the self-timer ( 71), set the self-timer before step 3, and then press the PHOTO button fully down.
- The wireless controller’s PHOTO button has no half-way setting. Press the button fully and the camcorder immediately takes the image.

#### The indicators that appear in the display when recording to a memory card:

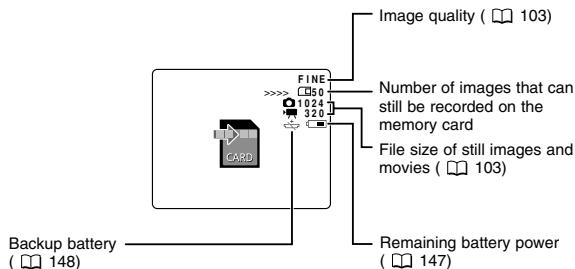

## Recording from a Tape in the Camcorder

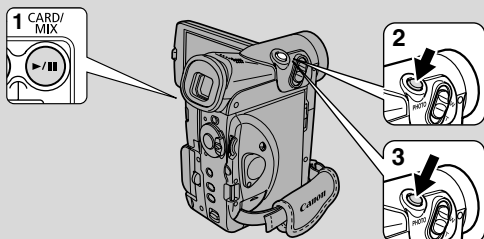
**E**

Record an image from a tape onto a memory card as still images. To automatically record multiple still images from a tape to a memory card, refer to “Copying Still Images from Tape to Memory Card” ( □ 138).

- The still image’s data code will reflect the date and time it has been recorded to the memory card.
- The image size of a still image recorded from tape onto a memory card will be 640 × 480.

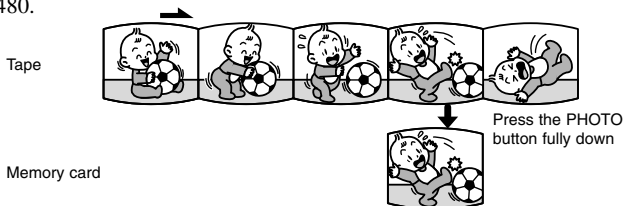
**CAMERA****PLAY (VCR)****CARD CAMERA****CARD PLAY (VCR)**

1. **Play back the tape.**
2. **When the image you want to record appears in the display, press the PHOTO button halfway down and hold it.**
  - The tape is set to playback pause mode and the number of images that can still be recorded on the memory card appears in the display.
3. **Press the PHOTO button fully down to record the still image to the memory card.**
  - The card access indicator flashes.

### **Notes:**

- You can also set the tape to playback pause mode in step 1 and record the image with only 1 full press of PHOTO button.
- If you record an image onto a memory card that was originally recorded in the 16:9 mode for wide screen TV’s, the image will appear to be vertically “squashed” (compressed).
- The shutter sound doesn’t sound in PLAY (VCR) mode.

## Recording from Other Video Devices

You can record images from a VCR or TV connected through the S-terminal or AV terminal (analog line-in), as well as images from other digital camcorders connected through the DV terminal onto the memory card as still images.

- The data code of the still image will reflect the date and time it has been recorded onto the memory card.
- The image size of a still image recorded from analog or digital devices onto a memory card will be  $640 \times 480$ .

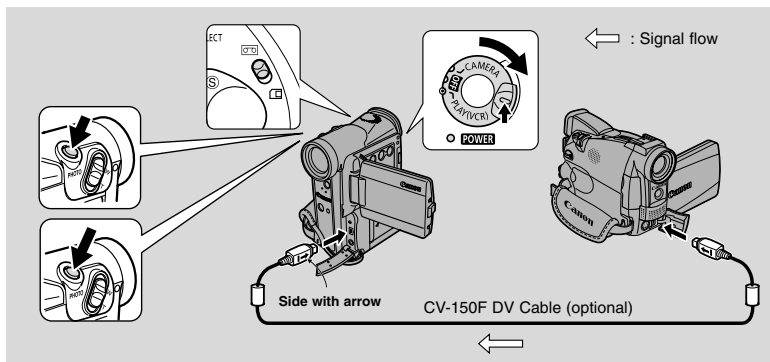

## Preparations

CAMERA

PLAY (VCR)

CARD CAMERA

CARD PLAY (VCR)

### 1. Connect the camcorder to the other device.

- S-video/AV terminal: See “Connections for Playback on a TV Screen” (□ 32).
- DV terminal: See “Dubbing to/from a Tape with Digital Video Equipment” (□ 86).

### 2. Prepare the other device.

### 3. Load a memory into the camcorder.

### 4. Turn the camcorder's POWER switch to PLAY (VCR), and move the camcorder's TAPE/CARD switch to TAPE.

- There is no need to load a cassette if you only record still images onto a memory card. If a cassette is inserted, make sure the cassette is in stop mode.

## Recording

---

1. **Start playback on the other device.**
2. **When the image you want to record appears in the display, press the PHOTO button halfway down and hold it.**
  - The image appears as a still image in the display.
  - The number of images that can still be recorded on the memory card appears in the display.
3. **Press the PHOTO button fully down to record the image to the memory card.**
  - The card access indicator flashes.



### Notes:

- When dubbing to a tape via the DV terminal, make sure that AV➡DV is not displayed on the screen. If so, set AV➡DV OUT to OFF in the menu ( 92).
- If you record an image onto a memory card that was originally recorded in the 16:9 mode for wide screen TV's, the image will appear to be vertically "squashed" (compressed).
- The shutter sound doesn't sound in PLAY(VCR) mode.

## Recording Motion JPEG Movies on a Memory Card



You can record Motion JPEG movies with the camcorder, from a tape in the camcorder, or from devices connected via the AV terminal (analog line-in) or the DV terminal.

### Cautions:

- When you are using an SD Memory Card, make sure the protect switch is set to allow recording.
- While the card access indicator flashes, do not turn off the camcorder, disconnect the power source or remove the memory card. Doing so could result in data damage.
- Do not load/unload a tape during recording. Sound will not be recording during this operation.



### Notes:

- Make sure a memory card with enough memory available is inserted into the camcorder.
- The sound of a movie recorded on a memory card will be monaural.

## Recording with the Camcorder

CAMERA

PLAY (VCR)

CARD CAMERA

CARD PLAY (VCR)

1. Turn the camcorder's POWER switch to CAMERA, and move the camcorder's TAPE/CARD switch to CARD.
2. Press the start/stop button.
  - You can record up to 10 seconds in  $320 \times 240$  and 30 seconds in  $160 \times 120$ .
  - Press the start/stop button to end recording.
  - The camcorder starts to write the movie to the memory card when recording is finished.



### Note:

- For using the self-timer (71), set the self-timer before step 2, and then press the start/stop button.

## Recording from a Tape in the Camcorder

You can record a movie from a tape to a memory card.

- The data code of the movie will reflect the date and time it has been recorded to the memory card.

CAMERA

**PLAY (VCR)**

CARD CAMERA

CARD PLAY (VCR)

1. Turn the camcorder's POWER switch to **PLAY (VCR)**, and move the camcorder's TAPE/CARD switch to **TAPE**.
2. Play back the cassette.
3. When the image you want to record appears in the display, press the start/stop button.
  - You can record up to 10 seconds in  $320 \times 240$  and 30 seconds in  $160 \times 120$ .
  - Press the start/stop button to end recording.
  - The camcorder starts to write the movie to the memory card when recording is finished.
  - You can also start recording during record pause mode by pressing the start/stop button.



### Note:

- If you record a movie to a memory card that was originally recorded in the 16:9 mode for wide screen TVs, the image will appear to be vertically "squashed" (compressed).

## Recording from Other Video Devices

You can record images from a VCR or TV connected through the S-terminal or AV terminal (analog line-in), as well as images from other digital camcorders connected through the DV terminal onto the memory card as movies.

- The data code of the movie will reflect the date and time it has been recorded onto the memory card.

### Preparations

CAMERA

PLAY (VCR)

CARD CAMERA

CARD PLAY (VCR)

#### 1. Connect the camcorder to the other device.

- S-video/AV terminal: See “Connections for Playback on a TV Screen” (□□32).
- DV terminal: See “Dubbing to/from a Tape with Digital Video Equipment” (□□86).

#### 2. Prepare the device.

#### 3. Insert a memory card into the camcorder.

#### 4. Turn the camcorder’s POWER switch to PLAY (VCR), and move the camcorder’s TAPE/CARD switch to TAPE.

- There is no need to load a cassette if you only record a movie onto the memory card. If a cassette is inserted, make sure the cassette is in stop mode.

### Recording

#### 1. Start playback on the other device.

#### 2. When the image you want to record appears in the display, press the start/stop button.

- You can record up to 10 seconds in  $320 \times 240$  and 30 seconds in  $160 \times 120$ .
- Press the start/stop button to end recording.
- The camcorder starts to write the movie to the memory card when recording is finished.
- You can also start recording during record pause mode by pressing the start/stop button.



#### Notes:

- When dubbing to a tape via the DV terminal, make sure that AV➡DV is not displayed on the screen. If so, set AV➡DV OUT to OFF in the menu (□□92).
- If you record a movie to a memory card that was originally recorded in the 16:9 mode for wide screen TVs, the image will appear to be vertically “squashed” (compressed).

## Recording Panoramic Images (Stitch Assist)

E

You can merge separate images into one large panoramic scene using the supplied software (PhotoStitch) on a PC. You can shoot a subject that won't fit into a single frame, such as a landscape, and stitch it together later.

### Recording

PhotoStitch detects the overlapping portions of adjoining images and merges them. When recording, try to include a distinctive item (landmark, etc.) in the overlapping portions.

CAMERA

PLAY (VCR)

CARD CAMERA

CARD PLAY (VCR)

**MENU**

(  39)

▶▶ STITCH AST

1. Turn the camcorder's **POWER** switch to **CAMERA**, and move the camcorder's **TAPE/CARD** switch to **CARD**.
2. Open the menu and select **▶▶ STITCH AST**.
  - Select the direction with the **CARD +/-** button and press the **SET** button. Press the **CARD +** button to move clockwise, press the **CARD -** button to move anticlockwise.
3. Set the recording program and zoom on the subject.
  - If necessary, set the focus manually and **AE** shift.
  - After the first image, recording program, zoom, and **AE** shift cannot be changed.
4. Press the **PHOTO** button to record the first image.
  - Direction and number of recorded images will be shown on the display.
5. Orient the camcorder so that the second frame overlaps a small portion of the first image and press the **PHOTO** button to take the next image.



- Do not worry about minor discrepancies in the overlapped area because the computer software can compensate for them when the images are merged.
  - You can retake images by pressing the **CARD -** button to return to the previous image.
  - A maximum of 26 images may be recorded.
  - Follow the same steps to shoot subsequent images in the sequence.
6. Finish the sequence by pressing the **MENU** button after the last image has been recorded.
    - Refer to the **DIGITAL VIDEO SOLUTION DISK** Software Instruction Manual for instructions on how to stitch them together.

**Notes:**

- Compose each image so that it overlaps 30 to 50% of the adjoining image. Try to keep the vertical misalignment within 10%.
- Do not include moving subject in the overlapping portion.
- Do not try to stitch images that include both distant and close subjects. They may appear warped or doubled up.

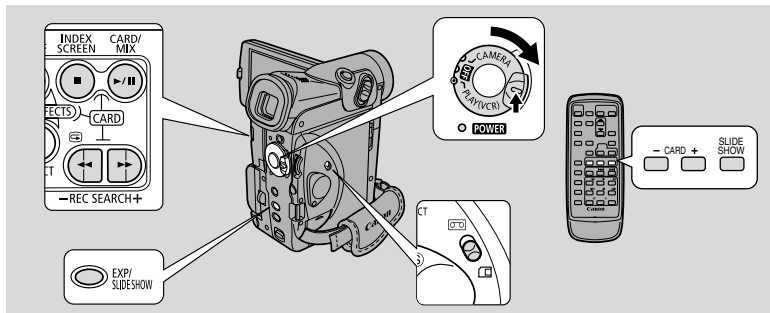

Play back and view still images/movies recorded on a memory card. (For details on connecting to a TV, see “Connections for Playback on a TV Screen” on p. 32.) You can also enlarge the still images by 2 times while viewing ( 79).

### There are 3 ways to view still images/movies:

- Single still images/movies
- Slide show: One after the other automatically in order of recording
- Index screen: Six still images/movies at once

### Caution:

- You may not be able to play back the following still images/movies correctly on this camcorder:
  - Still images/movies that have not been recorded with this camcorder but downloaded from a PC (excluding the sample images on p. 143)
  - Still images/movies that have been recorded with this camcorder but have subsequently been enhanced on a PC
  - Still images/movies whose image file names have been changed on a PC
- The camcorder may not be able to copy or play, etc., still images/movies recorded on a non-Canon camcorder.
- While the card access indicator flashes, do not turn off the camcorder, disconnect the power source or remove the memory card. Doing so could result in data damage.



### Notes:

- When the camcorder is in playback pause mode, you can use the Card Jump function to move quickly through still images/movies recorded anywhere on a memory card to find a still image/movie you want to view.
- Make sure a memory card that has still images/movies recorded on it is inserted into the camcorder.

## ● Single Image

CAMERA

PLAY (VCR)

CARD CAMERA

CARD PLAY (VCR)

### 1. Turn the camcorder's POWER switch to PLAY (VCR), and move the camcorder's TAPE/CARD switch to CARD.

- The last still image/movie recorded appears in the display.
- Movies will be displayed with the first scene as a still image.

### 2. Search for the desired still image/movie by pressing the CARD +/- buttons.

- Press + to view the next still image/movie and – to view the previous still image/movie.
- Pressing + at the last still image/movie will take you to the first still image/movie. Pressing – at the first still image/movie will take you to the last still image/movie.
- Movies: Pressing ►/|| plays back the movie and will show the last scene as a still image when playback ends. Pressing ►/|| during playback will stop the movie and the scene is shown as a still image. Pressing ►/|| again will restart the playback.

## ● Card Jump Function

You can locate still images/movies without displaying them one by one. The number in the upper right of the screen indicates the image number of the current image by the total number of images.

CAMERA

PLAY (VCR)

CARD CAMERA

CARD PLAY (VCR)

### In single image display, press and hold the CARD + or CARD – button.

- Press the CARD + button to jump forward and the CARD – button to jump backward.
- When you release the button, the still image/movie of the displayed image number appears.

## ● Slide Show

CAMERA

PLAY (VCR)

CARD CAMERA

CARD PLAY (VCR)

**With an still image/movie in the display, press the SLIDE SHOW button.**

- Still images are automatically played back one after another.
- Movies are played back normally.

**To stop the slide show, press the SLIDE SHOW button.**

- The slide show starts or stops each time you press the SLIDE SHOW button.

## ● Index Screen

Up to 6 still images/movies appear at once, allowing you to search quickly through the still images/movies. Movies will be displayed with the first scene as a still image, indicated by a movie frame.

CAMERA

PLAY (VCR)

CARD CAMERA

CARD PLAY (VCR)

**1. With an still image/movie in the display, press the INDEX SCREEN button.**

- Up to 6 images appear in the display.

**2. Move the frame to the still image/movie you want to view.**

- Turn the selector dial downwards to go to the previous still image/movie and upwards to go to the next still image/movie.
- Turning the dial upwards at the last still image/movie will take you to the next index screen. Turning the dial downwards at the first still image/movie will take you to the previous index screen.
- Jump to the next/previous index screen with the CARD +/- buttons.

**3. Press the INDEX SCREEN button.**

- The still image/movie you have marked fills the whole display.

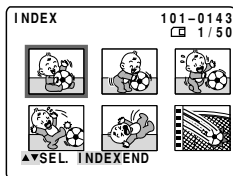

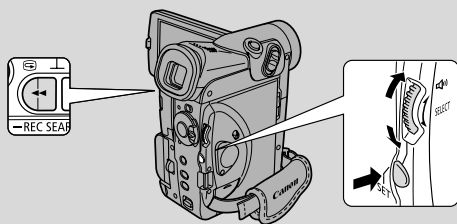

You can easily erase unwanted still images/movies recorded to the memory card while viewing them, protect them from accidental erasure, or mark a still image for printing. (File Operation)



- File Operation is set in CARD PLAY (VCR) mode.

## ● Preventing accidental erasure (Protect )

Select important still images/movies and protect them from accidental erasure.

- If a memory card is formatted, however, all still images/movies, including protected still images/movies, will be permanently erased.
- Movies can only be protected when the first or last scene is displayed as a still image. They cannot be protected during playback pause.
- The pre-recorded sample images provided on the supplied SD Memory Card are already protected.

There are 2 ways to protect still images/movies (including the ways to cancel the setting).

1. **CARD PLAY (VCR)** ➔ File Operation menu **SINGLE** (  122)
2. **CARD PLAY (VCR)** ➔ Card Operations submenu **INDEX** (  123)

## ● Marking a still image for printing (Print Mark )

A still image on a memory card must be marked before it can be printed. The camcorder supports the  DPOF (Digital Print Order Format) print format.



Still images can be automatically printed on a DPOF-supporting Canon Printer.

Up to 99 copies per still image and up to 200 still images per memory card can be selected on the camcorder.

- Movies cannot be marked for printing.

There are 3 ways to mark a still image for printing (including the ways to cancel the setting).

**To mark a still image for printing or erase print marks one at a time**

1. **CARD PLAY (VCR)** ➔ File Operation menu **SINGLE** (  122)
2. **CARD PLAY (VCR)** ➔ Card Operations submenu **INDEX** (  124)

**To erase all print marks**

3. **CARD PLAY (VCR)** ➔ Card Operations submenu **SINGLE** (  125)

## ● Erasing still images/movies

Erase still images/movies singly or all at once.

- You cannot erase protected still images/movies. Cancel image protection first in order to erase an image.
- Erase still images/movies with caution. Once a still image/movie has been erased, it cannot be restored.

There are 2 ways to erase a single still image/movie.

**To erase still images/movies one at a time**

1. **CARD PLAY (VCR)** ➔ File Operation menu **SINGLE** (  122)

**To erase still images/movies one at a time or erase all still images/movies on the memory card at once**

2. **CARD PLAY (VCR)** ➔ Card Operations submenu **SINGLE** (  126)

**SINGLE**: When playing back still images/movies in CARD PLAY (VCR) mode

**INDEX**: When displaying an index screen in CARD PLAY (VCR) mode





CAMERA

PLAY (VCR)

CARD CAMERA





CARD PLAY (VCR)

**1. With a still image/movie in the display, press the SET button to open the FILE OPER. menu.**

- PROTECT , PRINT MARK , and IMAGE ERASE settings appear.
- If you select RETURN, the menu disappears from the display.





To protect a still image/movie

**2. Select PROTECT  and press the SET button.**

- The  protect mark appears on the still image/movie.
- Now you are unable to erase this still image/movie.
- Press the SET button again to cancel it.
- If you select RETURN, the menu disappears from the display.
- To cancel image protection, select PROTECT  and press the SET button.  disappears and now you can erase this still image/movie.

To mark a still image for printing (Print Mark)

**2. Select PRINT MARK , set the number of prints with the selector dial and press the SET button.**

- The  print mark appears on the still image.
- If you select RETURN, the menu disappears from the display.
- To cancel a print mark, select PRINT MARK , set the number of prints to 0 (Zero) with the selector dial and press the SET button.  disappears.

To erase a still image/movie

**2. Select IMAGE ERASE and press the SET button.**

- ERASE THIS IMAGE? NO YES appears in the display.
- If you select RETURN, the menu disappears from the display.

**3. Select YES and press the SET button.**

- The still image/movie is erased.
- One still image/movie before the erased still image/movie appears.

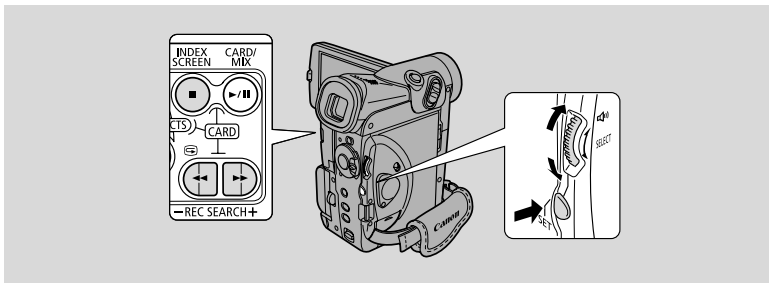

This section describes how to protect the still image/movie from the Card Operation submenu when displaying an index screen in CARD PLAY (VCR) mode (including the way to cancel the setting).

You can also protect a still image/movie through the File Operation menu (□ 122).

## Protecting a still image/movie while viewing an index screen

CAMERA

PLAY (VCR)

CARD CAMERA

**CARD PLAY (VCR)**
**MENU**

(□ 39)

► CARD OPER.

►► PROTECT

Make sure a memory card that has still images/movies recorded on it is inserted into the camcorder.

### 1. With a still image/movie in the display, press the INDEX SCREEN button.

- Up to 6 still images/movies appear in the display.
- Move the frame to the still image/movie that you want to protect (Index Screen □ 119)

### 2. Open the menu and select CARD OPER.

### 3. Select ►► PROTECT .

### 4. Press the SET button.

- The protect mark appears on the still image/movie.
- Now you are unable to erase this still image/movie.
- Press the SET button again to cancel it.

### 5. Close the menu.

#### Note:

- To cancel image protection, move the frame to the protected still image/movie and press the SET button in step 3. The protect mark disappears.

## Marking a Still Image for Printing (Print Mark)

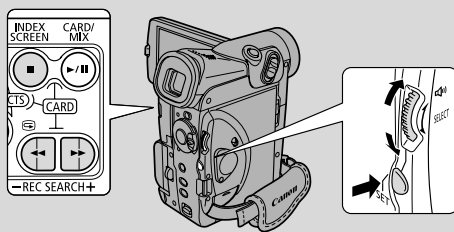

This section describes how to mark the still image for printing from Card operation submenu in CARD PLAY (VCR) mode (including the way to cancel the setting).

- When displaying an index screen, you can mark the still image for printing.
- When playing back a single still image, you can erase all print marks.
- Movies cannot be marked for printing. The frame on the index screen will turn purple, indicating that the movie cannot be selected for print mark.

You can also mark a still image for printing through the File Operation menu ( 122).

### Marking an a still image for printing while viewing an index screen

CAMERA

PLAY (VCR)

CARD CAMERA

CARD PLAY (VCR)

#### MENU

( 39)

▶CARD OPER.

▶▶PRINT MARK

Make sure a memory card that has a still image recorded on it has been inserted into the camcorder.

- 1. With a still image in the display, press the INDEX SCREEN button.**
  - Up to 6 images appear in the display.
  - Move the frame to the still image that you want to mark for printing (Index Screen 119).
- 2. Open the menu and select CARD OPER.**
- 3. Select ▶▶PRINT MARK and set the number of prints with the selector dial.**
- 4. Press the SET button.**
  - The print mark appears next to the still image.
- 5. Close the menu.**

### Notes:

- To cancel a print mark, move the frame to the print-marked still image, set the number of prints to 0 (zero) with the selector dial and press the SET button. The  print mark disappears.
- If there are a large number of images recorded on the memory card, it may take time for a print mark to appear on a still image.

## Erasing all print marks

CAMERA

PLAY (VCR)

CARD CAMERA

CARD PLAY (VCR)



### MENU

(  39)

▶ CARD OPER.

▶▶ PRINT MARKS  ALL ERASE

Make sure a memory card that has a still image recorded on it has been inserted into the camcorder.

1. **With a still image in the display, open the menu and select CARD OPER.**
2. **Select PRINT MARKS  ALL ERASE.**
  - ERASE ALL PRINT MARKS  ? YES NO appears in the display.
3. **Select YES and press the SET button.**
  - The  print mark disappears from the still image.
4. **Close the menu.**

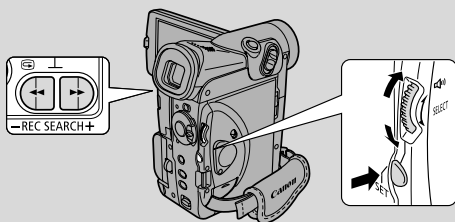

This section describes how to erase the still image/movie from the Card Operation submenu when playing back a single still image/movie in CARD PLAY (VCR) mode. (SINGLE or ALL)

You can also erase a still image/movie through the File Operation menu ( 122).

CAMERA

PLAY (VCR)

CARD CAMERA

CARD PLAY (VCR)

**MENU**

( 39)

▶ CARD OPER.

▶ IMAGE ERASE

Make sure a memory card that has still images/movies recorded on it is inserted into the camcorder.

To erase still images/movies one at a time

**1. Select the still image/movie you want to erase.**

- Use the index screen ( 119) or Card Jump function ( 118) if necessary and make sure the still image/movie you want to erase fills the display.
- If you use the index screen, press the INDEX SCREEN button after selecting the still image/movie. The still image/movie you selected fills the whole display.

**2. Open the menu and select CARD OPER.**

**3. Select IMAGE ERASE.**

- CANCEL, SINGLE and ALL settings appear.
- To cancel erasing, select CANCEL and close the menu.

**4. Select SINGLE.**

- ERASE THIS IMAGE? NO YES appears in the display.

**5. Select YES and press the SET button.**

- The still image/movie erases and the previous still image/movie appears for erasing.
- To erase another single still image/movie, move to that still image/movie with the CARD +/- buttons, and select YES.
- If the still image/movie you are trying to erase is a protected still image/movie, YES appears in purple and is unselectable.
- If you select NO, you return to step 4.

**6. Close the menu.**

To erase all still images/movies on the memory card at once

**1. Open the menu and select CARD OPER.****2. Select IMAGE ERASE.**

- CANCEL, SINGLE and ALL settings appear.
- To cancel erasing, select CANCEL and close the menu.

**3. Select ALL.**

- ERASE ALL IMAGES? [EXCEPT FOR  IMAGES] NO YES appears in the display.

**4. Select YES and press the SET button.**

- All still images/movies except the protected ones are erased.
- If you select NO, you return to step 2.

**5. Close the menu.**

## Printing with the Direct Print Function



E

You can print still images by connecting the camcorder to a printer with Direct Print function. The Direct Print function can also be used with the print mark settings ( 120).

### Cautions:

- Observe the following precautions during printing, otherwise printing may not be performed correctly.
  - Do not turn off the camcorder or the printer.
  - Do not change the position of the TAPE/CARD switch.
  - Do not detach the cable.
  - Do not remove the memory card.
- Still images not recorded with this camcorder may not be printed correctly on a printer with direct print function.

### Notes:

- The direct print function is supported by the Canon Card Photo Printer CP-10 and Canon Bubble Jet Printers with the  logo (as of march 2003).
- Refer to the instruction manual of each printer for information on which interface cable to use with the camcorder.  
The Card Photo Printer CP-10 is supplied with two direct interface cables. Use the cable with the USB logo on the connector (DIF-100).
- We recommend powering the camcorder from a household power source.
- Refer also to the instruction manual of the respective printer.
- Up to 99 copies per still image and up to 200 still images per memory card can be selected on the camcorder ( 120).
- The screenshots in this section are examples taken from a printer with direct print function. Options for the [Style] category will differ slightly depending on the printer.

## Connecting the Printer to the Camcorder

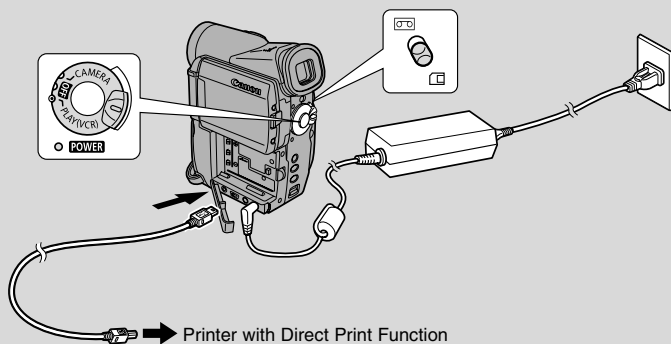

Using a Memory Card

1. Turn off the camcorder and insert a memory card that contains still images.

2. Connect a power source to the printer and turn on the printer.
3. Set the camcorder to **CARD PLAY (VCR) mode**.
  - Wait until the card access indicator stops flashing.
4. Connect the camcorder to the printer using the cable.
  - “**Print**»**SET**” appears when the printer is properly connected to the camcorder. (Does not appear with movies, or still images that cannot be played back with the camcorder.)

## Printing

CAMERA

PLAY (VCR)

CARD CAMERA

CARD PLAY (VCR)

1. In single image display, select the still image you wish to print and press the **SET** button.
  - The print setting menu appears.
2. Set the number of copies, the print style and the trimming settings.
  - Selecting the Number of Copies.
  - Setting the Print Style (□□ 130).
  - Trimming Settings (□□ 132).
3. Select [**Print**] and press the **SET** button.
  - Printing starts. The print setting menu disappears when printing is complete.



### Note:

- If an error message appears, see Printing Errors (□□ 134) and Direct Print Related Messages (□□ 166).

## Selecting the Number of Copies

A maximum of 9 copies can be selected for one still image.

1. In the print setting menu, turn the selector dial so that **9** appears next to [Copies] and press the **SET** button.
2. Turn the selector dial to select the number of copies and press the **SET** button.



## Setting the Print Style

### Card Photo Printer:

|         |            |  |
|---------|------------|--|
| Image   | Standard   | Prints 1 still image per page.                       |
|         | Multiple   | Prints 8 copies of the same still image on one page. |
| Borders | Borderless | Prints right to the edges of the page.               |
|         | Bordered   | Prints with a border.                                |

- [Multiple] can only be selected when printing on card size paper.
- [Borders] can only be selected when [Image] is set to [Standard].

### Bubble Jet Printer:

|            |   |                                       |
|------------|---|---------------------------------------|
| Paper Size | Card #1*, Card #2*, Card #3*, LTR, A4<br>For details on paper type, refer to the Bubble Jet Printer User Guide. |                                       |
| Borders    | Borderless  | Prints right to the edges of the page |
|            | Bordered  | Prints with a border                  |

\* Recommended paper size

### Card Photo Printer: Selecting the Image Style

1. In the print setting menu, turn the selector dial to select [Style] and press the SET button.



2. Make sure that  is selected and press the SET button.



3. Turn the selector dial to select the image style and press the SET button.
4. Press the MENU button.
  - You return to the print setting menu.

## Bubble Jet Printer: Selecting the Paper Size

1. In the print setting menu, turn the selector dial to select [Style] and press the SET button.



2. Make sure that  is selected and press the SET button.



3. Turn the selector dial to select the paper size and press the SET button.
4. Press the MENU button.
  - You return to the print setting menu.

## Selecting the Borders

1. In the print setting menu, turn the selector dial to select [Style] and press the SET button.



2. Turn the selector dial to select  and press the SET button.



3. Turn the selector dial to select a setting option and press the SET button.
4. Press the MENU button.
  - You return to the print setting menu.

### Notes:



- Bordered: The image area remains relatively unchanged from the recorded image when it is printed.
- Borderless/Multiple: The centre portion of the recorded image is printed at an enlarged size. The image's top, bottom and sides may be cropped slightly.
- Card Photo Printer: A still image set to [Multiple] will be printed without borders.

### Card Photo Printer: Selecting the Printing Area

[Printing Area] can be selected when the still image is set to [Borderless].

1. In the print setting menu, turn the selector dial to select [Printing Area] and press the SET button.



2. Select a setting option and press the SET button.
  - The printing area is  for standard images and  for multiple images.



3. Press the SET button.

### Bubble Jet Printer: Trimming Settings

Set the print style before you start with the trimming settings.

1. In the print setting menu, turn the selector dial to select [Trimming] and press the SET button.
  - The trimming frame appears.



## 2. Change the size of the trimming frame.

- Move the zoom lever toward **T** to shrink the frame, and toward **W** to enlarge the frame.
- To cancel the trimming settings, move the zoom lever toward **W** until the trimming frame disappears.

## 3. Move the trimming frame.

- Turn the selector dial to move the image to the right and left, or up and down. Pressing the SET button switches between the directions.

## 4. Press the MENU button.

- You return to the print setting menu.



### Notes:

- About the color of the trimming frame:
  - White: No trimming settings.
  - Yellow: During trimming.
- The trimming frame may not appear depending on the image size, paper size or borders settings.
- The trimming setting applies only to one image.
- The trimming setting is canceled with the following operations:
  - When you turn off the camcorder.
  - When you disconnect the interface cable.
  - When you expand the trimming frame beyond its maximum size.

## Printing with Print Mark Settings

You can print still images you have selected with the Print Mark function. If you wish to print more than 1 copy, set the number of copies in the print mark settings (☞ 120).

When printing with print mark settings, you can select the print style such as bordered or borderless, but not the trimming settings.

CAMERA

PLAY (VCR)

CARD CAMERA

CARD PLAY (VCR)

**MENU**

(☞ 39)

▶▶▶ PRINT

1. Connect the printer to the camcorder (☞ 128).

2. Press the MENU button.

### 3. Select [➡ ▶ PRINT].

- The print setting menu appears.
- “Set print order” appears, when you connect a printer with direct print function and select [➡ ▶ PRINT] without having set the print mark settings.
- The total number of prints set in the print mark settings is displayed on the upper left of the screen.

### 4. Set the print style.

- Setting the Print Style (📖 130).

### 5. In the print setting menu, turn the selector dial to select [OK] and press the SET button.

- Printing starts. The print setting menu disappears when printing is complete.



#### Notes:

##### • Cancel Printing

Press the SET button while “Now Printing” is displayed. A confirmation dialog appears. Select [OK] and press the SET button. Printing stops even if it is incomplete and the paper is fed through.

##### • Restarting Printing (with ▶ print mark only)

Open the CARD PLAY (VCR) menu and select [➡ ▶ PRINT]. Select [Restart] in the print setting menu and press the SET button. The remaining images will be printed.

Printing cannot be restarted in the following cases:

- When you change the print mark settings.
- When you delete a single image with print mark settings.

##### • Printing Errors

- If an error occurs during the printing process, an error message appears (📖 166).
- Bubble Jet Printer: With most errors, printing resumes automatically after you correct the error. If the error persists, press the SET button to cancel printing. Refer also to the Bubble Jet Printer Quick Start Guide for details.
- Card Photo Printer: Turn the selector dial to select [Stop] or [Restart] and press the SET button. (The [Restart] setting may not appear with some error messages. In that case, select [Stop].)

##### • Follow below procedure when disconnecting the interface cable:

1. Disconnect the cable from the camcorder and printer.
2. Turn off the camcorder.

## Combining Images and Recording Them to a Cassette (Card Mix)



E

Enhance the appearance of your recordings by combining still images from the memory card with camcorder recordings. You may select from pre-recorded cartoon-like frames, or create personal frames and titles that can be layered over movies or still images.



### Note:

- Additional sample images are provided on the supplied DIGITAL VIDEO SOLUTION DISK. For instructions on how to upload them to the memory card, refer to “Adding Still Images from Your Computer to the Memory Card” in the DIGITAL VIDEO SOLUTION DISK Software Instruction Manual.

### Select from 3 types of Card Mix effects:

#### CARD CHROMA (Card chroma key)

Combine the image you are recording with a still image as a frame. The image will be shown instead of the blue area of the still image. When recording your own “frame”, make sure that the area you wish the other image to appear is blue. Adjustment of the MIX LEVEL: blue area of the still image.

Image being recorded by the camcorder



+

Still image



→



#### CARD LUMI. (Card luminance key)

Combine the image you are recording with illustrations or titles. The image will be shown instead of the light area of the still image. Create your own title or illustration by drawing or writing on a white paper and recording it to the memory card.

Adjustment of the MIX LEVEL: light area of the still image

Image being recorded by the camcorder



+

Still image



→





4. **Select MIX TYPE.**
  - CARD CHROMA, CARD LUMI., CAM. CHROMA settings appear.
5. **Select the desired setting.**
  - Your currently recording image is combined with the pre-recorded still image.
6. **Select MIX LEVEL and press the SET button.**
7. **Adjust the mix level.**
  - Turning the selector dial upwards adjusts to the right and turning downwards adjusts to the left.
8. **Close the menu.**
  - CARD MIX flashes in the display.



On/Off

9. **Press the CARD MIX button.**
  - CARD MIX stops flashing.
  - Your currently recording image is combined with the pre-recorded still image.
  - Each time you press the card MIX button, your selection is activated (display lights continuously) or deactivated (display flashes).

For movies

1. **Press the start/stop button to start and stop recording.**
  - The combined images are recorded onto the tape.

For stills

1. **Press the PHOTO button halfway down and hold it.**
  -  flashes white in the display as the camcorder adjusts the focus and it is displayed continuously as a green mark when the camcorder is ready to take the image.
2. **Press the PHOTO button fully down to record the image to the tape.**
  -  disappears from the display.
  - The combined images are recorded onto the tape for approximately 6 seconds.



#### Notes:

- If you change the position of the POWER switch, select your still image for Card Mix again.
- When setting Card Mix, you must carry out steps 1 to 5.

## Copying Still Images from Tape to Memory Card

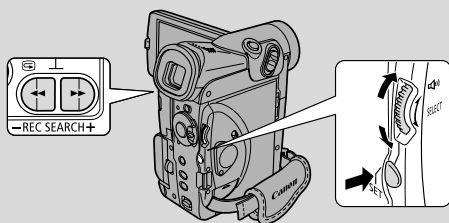

Copies multiple still images from a tape to the memory card, using the Photo Search function.

- The still images' data codes will reflect the date and time the copies are made.
- The image size of a still image copied from tape to memory card will be 640 × 480.

CAMERA

PLAY (VCR)

CARD CAMERA

CARD PLAY (VCR)

**MENU**

( 39)

▶ CARD OPER.

▶ COPY [ ]

Make sure a memory card that has enough memory available and a recorded tape have been inserted into the camcorder.

### 1. Locate the first still image on the tape that you want to copy and stop the tape at a point before that image.

- All the still images on the tape after that point will be copied onto the memory card.
- If you want to copy all the images on a tape, rewind the cassette to the beginning.

### 2. Open the menu and select **CARD OPER.**

### 3. Select **COPY [ ]**.

- CANCEL and EXECUTE settings appear.

### 4. Select **EXECUTE** and press the **SET** button.

- Select CANCEL to stop copying.
- Tape and card information appear in the display and copying starts.
- NOW COPYING [ ] appears in the display.
- The camcorder automatically performs the Photo Search function to locate still images and copying starts. The currently copying image appears in the display.
- Copying stops when the tape is finished or the memory card is full. When the memory card is full, CARD FULL will appear in the display.

### 5. Press the stop button when your desired images have finished copying.

## Copying Still Images from Memory Card to Tape

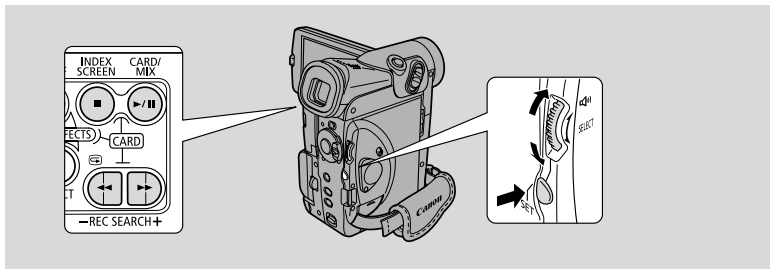
**E**



Copies multiple still images from the memory card to a tape.

- The still images' data codes will reflect the date and time the copies are made.

### MENU

( 39 )

▶ CARD OPER .

▶▶ COPY [  →  ]

Make sure a memory card that has images recorded on it and a cassette that has enough recordable space have been inserted into the camcorder.

CAMERA

PLAY (VCR)

CARD CAMERA

CARD PLAY (VCR)





1. **Locate the point on the cassette where you want to start copying and set it to stop.**

CAMERA

PLAY (VCR)

CARD CAMERA

CARD PLAY (VCR)

2. **Select the first image you want to copy by using the CARD +/- buttons.**
  - Still images on the memory card including and after that image will be copied onto the tape.
  - If you want to copy all the still images on the memory card, select the first image.
3. **Open the menu and select CARD OPER.**
4. **Select COPY [  →  ] and press the SET button.**
  - CANCEL and EXECUTE settings appear.
5. **Select EXECUTE and press the SET button.**
  - Select CANCEL to stop copying.
  - Tape and card information appear in the display and copying starts.
  - NOW COPYING [  →  ] appears in the display.
  - Each image is copied for about 6 seconds on the tape.
  - Copying stops when all the images have been copied or the tape is full.
6. **Press the  button when your desired images have finished copying.**

## Formatting a Memory Card

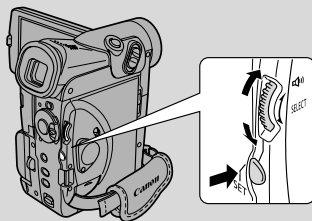
**E**

Format new memory cards, if you get the message **CARD ERROR**, or to permanently and quickly erase all the still images/movies on a memory card, including protected still images/movies (this includes the pre-recorded card mix sample images).

The SD Memory Card supplied with this camcorder has already been formatted for you.

- Be cautious when formatting recorded memory cards. All still images/movies will be permanently erased.
- If you use memory cards other than the supplied one, make sure to format them with the camcorder, not a PC or other device.

CAMERA

PLAY (VCR)

CARD CAMERA

CARD PLAY (VCR)

**MENU**

( 39)

▶ CARD OPER.

▶▶ FORMAT

Make sure a memory card is inserted into the camcorder.

1. **Open the menu and select CARD OPER.**
2. **Select FORMAT and press the SET button.**
  - CANCEL and EXECUTE settings appear.
3. **Select EXECUTE and press the SET button.**
  - Select CANCEL to cancel formatting.
  - FORMAT THIS CARD? NO YES appears to confirm.
4. **Select YES and press the SET button.**
  - Formatting starts.
  - If you select NO, you return to step 3.
5. **Close the menu.**

## Connecting to a Computer Using a USB Cable

You can download images from the memory card to a computer using the supplied USB cable. With the supplied software, you can easily download, browse and archive images, and arrange still images for printout.

For Windows XP and Mac OS X users:

Your camcorder is equipped with the standard Picture Transfer Protocol (PTP). This protocol enables you to download images by simply connecting the camcorder to a computer with the USB cable (a software such as the [Scanner and Camera Wizard] starts automatically) without installing the software from the DIGITAL VIDEO SOLUTION DISK.

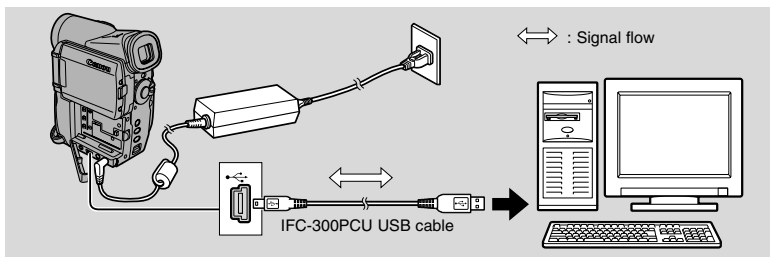

**For instructions on how to connect the camcorder to the computer, and install and operate the software, refer to the DIGITAL VIDEO SOLUTION DISK Software Instruction Manual.**

- Refer also to the computer instruction manual.
- "PC CONNECT" appears to indicate that the camcorder is connected to the computer via USB cable.



### Cautions:

- Do not disconnect the USB cable, remove the memory card, change the position of the POWER switch or turn off the camcorder and computer while data is being transferred to the computer (while the camcorder's card access indicator is flashing). Doing so may damage the memory card's data.
- Operation may not work correctly depending on the software and the specifications/settings of your computer.
- The image file on your memory card and the image files saved on the hard disk drive of your computer are valuable, original data files. If you wish to use image files on your computer, make copies of them first, and use the copied file, retaining the original.

### Notes:

- We recommend powering the camcorder from a household power source while it is connected to the computer.
- For transferring recordings from to a computer using a DV cable, see p. 101.
- Still images/movies recorded on a tape cannot be transferred to a computer via USB interface.

## Other Information and Precautions



The camcorder formats memory cards in DCF (Design rule for Camera File system).

Still images/movies recorded on a memory card with this camcorder can also be transferred to a PC with the use of the following products made for SD Memory Cards or MultiMediaCards:

- PC Card Adapter: Holds a memory card then inserts into the PC card slot found on most types of laptop PCs.
- USB Reader/Writer: Connects to the USB port of a computer for direct access to the memory card.
- FD Adapter: Holds a memory card then inserts into a PC's floppy disk drive.

### Memory Cards confirmed to operate with this camcorder (as of March 2003)

SD Memory Card—

Panasonic: 16 MB, 32 MB, 64 MB, 128 MB, 256 MB, 512 MB

SanDisk: 16 MB, 32 MB, 64 MB

MultiMediaCard—

SanDisk: 16 MB, 32 MB, 64 MB

- However, we cannot guarantee that all of these memory cards work properly.

If you mistakenly erase the card mix sample images provided on the SD Memory Card, they can be downloaded from the following home pages:\*

<http://www.canon-europa.com/products/products.html>

<http://www.canon-asia.com/>

<http://www.canon.com.au>

For details on how to add the downloaded images to the memory card, refer to “Adding Still Images from Your Computer to the Memory Card” in the DIGITAL VIDEO SOLUTION DISK Software Instruction Manual.

\*If you are unable to connect the camcorder to a PC using a USB cable, you will need a PC Card Adapter or USB Card Reader to be able to download to a memory card.

### Memory card operating precautions

- If you purchase additional memory cards, format them with the camcorder, not a PC or other device. There have been cases where memory cards formatted with a PC or other device do not function properly.
- We recommend saving backups of memory card images on your PC's hard drive or other external memory device. Image data may be damaged or lost due to a defect in a memory card, or if a memory card is exposed to static electricity. Contents of a memory card cannot be compensated for should data become damaged or lost.
- Do not turn off the camcorder, disconnect the power source or remove the memory card while the card access indicator is flashing.

- Do not use memory cards in places subject to strong magnetic fields.
- Do not disassemble memory cards.
- Do not bend or drop memory cards, or expose them to strong vibrations or external shocks.
- Do not get memory cards wet.
- Do not remove the memory card's label or affix other labels. Affix labels to the memory card's case.
- Do not leave memory cards in places subject to high temperature or high humidity.
- Moving a memory card rapidly between hot and cold temperatures may cause condensation to form on it, leading to malfunctions. Avoid this problem by placing the memory card in a plastic bag and letting it slowly adjust to temperature changes before removing it from the bag. If condensation should occur, maintain the memory card at a constant temperature and let the moisture evaporate naturally.
- Do not touch the memory card's terminals or let dust or dirt come in contact with the terminals. Store and carry memory cards in their case to protect the terminal area.
- There is only one correct way to insert memory cards into the camcorder. Do not forcefully insert the memory cards backwards or upside down. This could damage the memory card or the camcorder.

### Sample images

- The following are the sample images that have been pre-recorded on the supplied SD Memory Card. There are a total of 15 images: 8 Card chroma key images, 5 Card luminance key images and 2 Camera chroma key images.

#### Card chroma key

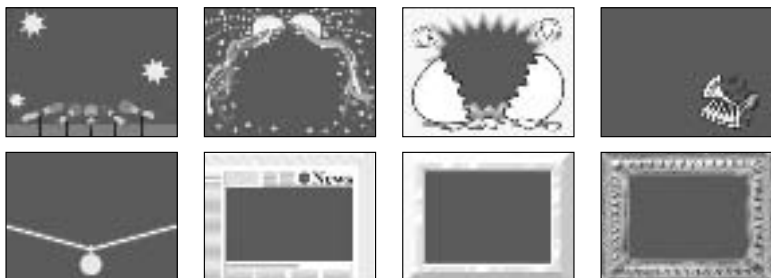

## Card luminance key

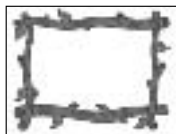
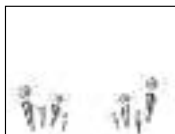

## Camera chroma key



- The pre-recorded sample images on the supplied SD Memory Card are intended solely for the personal enjoyment gained from combining them with personal videos taken with this camcorder. Do not use the pre-recorded sample images for any other purpose.

## SD Memory Card SDC-8M Specifications

|                                    |                         |
|------------------------------------|-------------------------|
| <b>Capacity</b>                    | 8 MB                    |
| <b>Interface</b>                   | SD Memory Card standard |
| <b>Operating temperature range</b> | 0°C–40°C                |
| <b>Dimensions</b>                  | 32 × 24 × 2.1 mm        |
| <b>Weight</b>                      | 2 g                     |

Weight and dimensions are approximate.

Errors and omissions excepted.

Subject to change without notice.

PhotoEssentials - Royalty Free Stock Photography

The PhotoEssentials suite of royalty-free images on CD-ROM features premium quality assignment photography and is ideally suited for use in advertising, brochures, reports, multimedia, websites, books, packaging and more.

For more information, please visit their website [www.photoessentials.com](http://www.photoessentials.com)

## Preparing the Camcorder

### Adjusting the viewfinder

- Set the camcorder to CAMERA mode. Adjust the viewfinder focusing lever to suit your eyesight.
- To view with the viewfinder, make sure the LCD panel is either turned so that the subject can monitor viewing, or totally closed with the screen facing inwards.

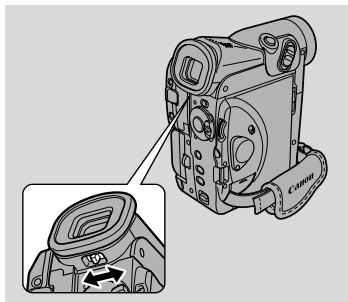

Be careful not to leave the viewfinder exposed to bright sunlight, or it will melt. (The light is concentrated by the viewfinder lens.) Do not direct the viewfinder to the sun.

### Preparing the lens cap

- Attach the cord to the lens cap, and pass the grip belt through the loop on the cord.
- Hook the lens cap on to the grip belt while you are recording, and place it over the lens when you have finished.

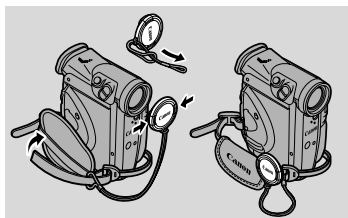

### Fastening the grip belt

- Release the Velcro fastening and hold the camcorder with your right hand while you adjust the belt with your left. Your index finger should reach the zoom control and photo button, and your thumb should reach the start/stop button comfortably.



E

## Notes on Using the Batteries

**E**

### Charging and recording times

- These times vary — the safest policy is always to have 2 or 3 times as many battery packs as you think you will need.
- You will get more recording time if you turn the camcorder off between shots, instead of leaving it in record pause mode.
- Charge the battery pack in temperatures between 10°C and 30°C (50°F and 86°F).
- The charging time varies depending on the charging conditions.

| Battery Pack       | Time needed for full recharge |
|--------------------|-------------------------------|
| NB-2L              | 80 min.                       |
| BP-2L12 (optional) | 150 min.                      |

| Battery Pack       | Max. Recording Time  |                      | Typical Recording Time* |                      |
|--------------------|----------------------|----------------------|-------------------------|----------------------|
|                    | Using the Viewfinder | Using the LCD Screen | Using the Viewfinder    | Using the LCD Screen |
| NB-2L              | 80 min.              | 60 min.              | 40 min.                 | 30 min.              |
| BP-2L12 (optional) | 170 min.             | 125 min.             | 90 min.                 | 70 min.              |

\* Typical Recording Time: Approximate times for recording with repeated operations such as start/stop, zooming and power on/off. The actual time may be shorter.

- You can use the battery pack between 0° and 40°C (32° to 104°F), but it works best between 10° and 30°C (50° to 86°F). Operating time will be shorter than usual at low temperatures like a ski ground. For better operating results, the battery pack can be warmed in your pocket or someplace and then used.
- If the battery pack starts to give you much less operating time than usual (at normal temperatures), it has reached the end of its life and must be replaced.
- These figures show how long you can view playback with the LCD, after attaching a fully-charged battery pack. Playback time will be shortened at low temperatures.

| Battery pack       | Playback time (using the LCD screen) |
|--------------------|--------------------------------------|
| NB-2L              | 55 min.                              |
| BP-2L12 (optional) | 120 min.                             |

## How much power is left?

The battery symbols indicate the charge status of the battery pack. When the battery pack is empty, “CHANGE THE BATTERY PACK” appears for 4 seconds and  starts flashing.

The battery charge indicators are not constant – they vary according to the condition under which battery pack and camcorder are used.

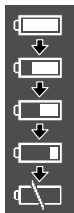

## When to recharge

You can recharge a lithium ion battery pack whenever it is convenient. Unlike a conventional battery pack, it does not have to be fully discharged first. However, as the battery pack will naturally discharge itself over time, it is best to charge it the same day you plan to use it, or the day before.

## Taking care of the battery pack

### Always attach the terminal cover.

- Do not allow any metal objects to touch the terminals, as this can cause a short circuit and damage the battery pack. Attach the terminal cover whenever the battery pack is not being used.

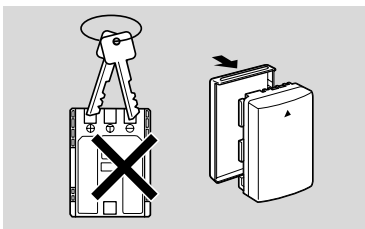

### Keep the terminals clean.

- The camcorder, adapter or battery pack will not work properly if the terminals are dirty. Attach the terminal cover whenever the battery pack is not being used.

### Storing the battery pack.

- Storing a charged battery pack for long periods of time (about 1 year) can shorten its lifecycle or affect performance. We recommend to discharge the battery pack in the camcorder fully and to store it in a dry place. If you do not use the battery pack for long periods of time, charge it fully and discharge it fully in the camcorder at least once a year before returning it to storage.

## Installing the backup battery

Press the small button with a pen and pull out the battery holder. Insert the battery into the battery holder so that the + side of the battery faces the + sign on the battery holder. Insert the battery holder back into place.

This backup battery allows the camcorder to remember the date and time and other settings when main power source is removed. It has a life span of about a year.

When it needs replacing (or if it has not been installed), the  mark flashes in the display.

Remove the old battery by pushing up then releasing and lifting out. Make sure to attach a power source to the camcorder first, so it will remember your chosen settings when you change the battery.

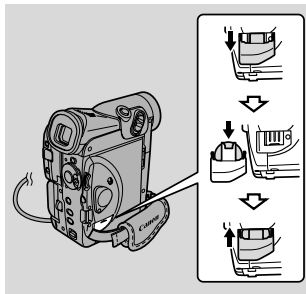

### DANGER!

#### Treat the battery pack with care.

- Keep it away from fire (or it might explode).
- Do not expose the battery pack to temperatures greater than 60°C (140°F). Do not leave it near a heater, or inside a car in hot weather, for example.
- Do not try to disassemble or modify it.
- Do not drop or knock it.
- Do not get it wet.

### WARNING!

- The battery used in this device may present a fire or chemical burn hazard if mistreated. Do not recharge, disassemble, heat above 100°C (212°F) or incinerate.
- Replace the battery with a CR1616 made by one of the following companies: Panasonic, Hitachi Maxell, Sony, Toshiba, Varta, Renata. Use of other batteries may present a risk of fire or explosion.
- The used battery should be returned to the supplier for safe disposal.

### Cautions:

- Do not pick up the battery using tweezers or other metal tools — this will cause a short circuit.
- Wipe the battery with a clean, dry cloth to ensure proper contact.
- Keep the battery pack out of reach of children — if it is swallowed, contact a physician immediately, as the battery case may break down and the battery fluids damage the stomach and intestines.
- Do not disassemble, heat or immerse the battery in water, to avoid the risk of explosion.

## Cautions

### **Avoid high temperatures and high humidity.**

- Do not leave the camcorder inside a car in hot weather, for example.
- Be careful of heat radiating from video lighting equipment.
- Do not take the camcorder into a humid room.

### **Avoid sudden changes in temperature.**

- If you take the camcorder from a cold place to a warm place, condensation may form on the lens and internal parts (□ 152).

### **Do not point the lens or viewfinder at strong light sources.**

- Never point it at the sun, and do not leave it aimed at a bright subject.
- Be especially careful when leaving the camcorder on a tripod.

### **Avoid magnetic or electric fields.**

- Do not use the camcorder close to TV transmitters, portable communication devices or other sources of electric or magnetic radiation. They may cause picture interference, or permanently damage the camcorder.

### **Do not expose the camcorder to water.**

- Cover the camcorder when you are recording in rain or mist.
- There is a risk of electric shock if water gets inside the camcorder — contact qualified service personnel as soon as possible.

### **Protect the lens.**

- Sand and dust can damage the lens — be especially careful on windy days.

### **Handle the camcorder gently.**

- Vibration or shock can cause damage.
- Do not use the viewfinder or LCD panel as a carrying handle.

### **Do not disassemble the camcorder.**

- This is very dangerous as there is a risk of electric shock — if the camcorder does not function properly, take it to qualified service personnel.

## Storage

If you do not intend to use the camcorder for some time, store it in an area which is free of dust and moisture, and where the temperature is no higher than 30°C (86°F). After storage, check each part and function of your camcorder to make sure everything is still working properly.



### Note:

- These cautions also apply to accessories such as battery packs and cassettes.

## Maintenance

### LCD

- Clean the LCD screen using a commercially available cleaning cloth for glasses.
- Where there is a big change in temperature, moisture may form on the surface of the screen. Wipe clean with a soft, dry cloth.
- At low temperatures the display may appear to be much darker than usual. This is not a fault, and as the screen warms up the display will return to normal.

### Camcorder body and lens

- Use a soft, dry cloth to clean the camcorder body or lens. Never use chemically treated cloth or volatile solvents such as paint thinner.

### Video heads

- When the message “HEADS DIRTY, USE CLEANING CASSETTE” appears, or when the playback picture becomes distorted, the video heads need to be cleaned.
- To maintain the best picture quality, we recommend cleaning the video heads frequently with the Canon DVM-CL Digital Video Head Cleaning Cassette or a commercially available dry cleaning cassette.
- Do not use wet type cleaning cassettes as this may damage the camcorder.



## Using the camcorder abroad

E

### Power sources

- You can use the compact power adapter and battery charger to operate your camcorder and charge battery packs in any country where the electricity supply is between 100 and 240 V AC, 50/60 Hz. Contact your Canon dealer for information about plug adapters for overseas use.

### TV playback

- Although you can always play back your recordings on the LCD screen, your camcorder can only be connected to TVs which use its PAL system. This TV system is used in the following countries:  
Algeria, Australia, Austria, Bangladesh, Belgium, Brunei, China, Denmark, Finland, Germany, Hong Kong Special Administrative Region, Iceland, India, Indonesia, Ireland, Italy, Jordan, Kenya, Kuwait, Liberia, Malaysia, Malta, Mozambique, the Netherlands, New Zealand, North Korea, Norway, Oman, Pakistan, Portugal, Qatar, Sierra Leone, Singapore, South Africa, Spain, Sri Lanka, Swaziland, Sweden, Switzerland, Tanzania, Thailand, Turkey, Uganda, United Arab Emirates, United Kingdom, Yemen, former Yugoslavia, Zambia.

## Condensation

Condensation may form on the camcorder when it is moved from a cold place to a warm place. Using the camcorder while condensation is present can damage both the tape and the camcorder.

Condensation may become a problem:

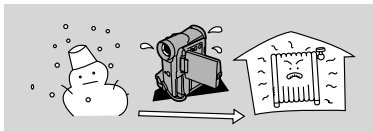

When you take the camcorder from a cold place to a warm room

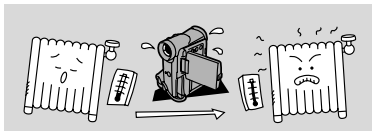

When a cold room is heated rapidly

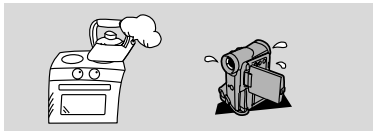

When the camcorder is left in a humid room

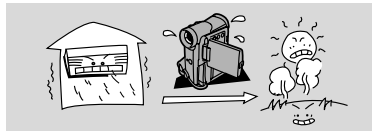



When the camcorder is taken from an air-conditioned room to a warm, humid place

### Protecting the camcorder from condensation

- Before you take the camcorder to a warm or humid place where condensation is likely to be a problem, unload the cassette and put the camcorder in a plastic bag. Wait until the camcorder reaches room temperature before you take it out of the bag.

### What happens when condensation is detected

- “CONDENSATION HAS BEEN DETECTED” is displayed for approximately four seconds. Then, the power indicator flashes and the  mark flashes in the display. If there is a cassette in the camcorder, it stops automatically and “REMOVE THE CASSETTE” is displayed for approximately 4 seconds and then  flashes in the display. If you have the beep turned on, it will sound.
- The camcorder may not detect the condensation immediately — the condensation warning may not start flashing for 10 to 15 minutes.
- You cannot load a cassette when condensation is detected.

### What you should do

- Remove the cassette, leave the cassette compartment open, and turn the camcorder off.
- Leave it in a dry place until the condensation evaporates. After the condensation warning stops flashing, wait at least another hour before trying to use the camcorder.

## Troubleshooting

E

Refer to this checklist first if you have any problems with your camcorder. Possible explanations are given for each problem on the list — turn to the page numbers in parentheses for more information.

Make sure that the camcorder is properly connected if you are using it with a TV or VCR. Consult your dealer or service outlet if problems persist.

### Recording/Playback

#### Problem

**2** Nothing happens when I press the buttons.

**2** The camcorder turned itself off.

**2** The cassette compartment stopped mid-operation while loading/unloading a cassette.

**2** The start/stop button doesn't work.

**2** There's no picture in the display.

**2** There's a blank blue screen in the display.

#### Cause and/or what to do about it

- The camcorder is not set to the appropriate mode ( □ 18, 28).
- The cassette is not loaded or is set for erasure prevention ( □ 16-17).
- The cassette has reached the end.
- The power source is not properly connected, or the battery pack is exhausted or not properly attached ( □ 12-15, 147).
- The function cannot be used in that recording program ( □ 57).
- The camcorder was in record pause mode for more than about 5 minutes ( □ 18, 107, 163).
- The battery pack is exhausted ( □ 14-15, 147).
- The battery pack's power is exhausted. Recharge or change to a new battery pack ( □ 14-15).
- The cassette is not loaded or is set for erasure prevention ( □ 16-17).
- The cassette has reached the end.
- The camcorder is not set to the appropriate mode ( □ 18, 28).
- You are attempting to play back or record copyright protected material ( □ 88).
- The video heads are badly contaminated ( □ 150).

## 2 The camcorder won't focus.

- The camcorder is on manual focus ( 76).
- The viewfinder lens needs adjusting ( 145).
- The lens is dirty ( 150).



### Note:

- Some subjects are not suitable for autofocus. In these situations, you will often get better results using manual focus ( 76). Focus on something which is about the same distance away, lock the focus, and then point the camcorder at your original, hard-to-focus subject.



Horizontal stripes



Many subjects at different distances



Behind glass

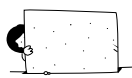

Without much contrast (e.g. a white wall)



Reflective surfaces  
(e.g. shiny car surfaces)



Fast moving objects



Dark subjects



Night scenes

## Recording/Playback (Cont.)

### Problem

#### 2 Some/all of the digital effects don't work.

#### 2 The ► (play) button doesn't work.

#### 2 There's a bright stripe on the screen.



#### 2 The playback picture is rough (with mosaic-like noise).

### Cause and/or what to do about it

- There are a number of restrictions on using the digital effects ( 61-68).
- The camcorder is not set to PLAY (VCR) mode ( 28).
- The cassette is not loaded ( 16).
- The cassette has reached the end.
- When recording in dark places a bright light in the scene may cause a vertical light bar ("smear") to appear. This is a normal feature of camcorders.

- The video heads need cleaning ( 150).

- ❗ **There's no picture on the TV screen.**
  - AV/PHONES is not set to AV in the menu (□□ 32).
  - AV → DV OUT (Analog-digital converter) is not set to OFF in the menu (□□ 92).
- ❗ **There's no picture on the TV screen, even though the tape is moving.**
  - The video heads need cleaning (□□ 150).
  - The TV/VIDEO selector on the TV isn't set to VIDEO (□□ 33-35).
- ❗ **There's no sound coming from the speaker during playback.**
  - The speaker has been turned off with the selector dial (□□ 31).
  - Headphones are being used.

### Memory card operations

#### Problem

- ❗ **The memory card will not insert.**
- ❗ **The □ mark flashes red in the display even though a memory card has been inserted.**
- ❗ **Nothing happens when I press the buttons.**

#### Cause and/or what to do about it

- It is not turned the right way (□□ 102). Turn it the right way and try inserting again.
- Turn the camcorder's power off and back on again and remove and reinsert the card. If the mark continues to flash, format the memory card.
- The camcorder is not set to CARD CAMERA or CARD PLAY (VCR) (□□ 107, 117) mode.
- The memory card is not inserted (□□ 102).
- You are using an SD Memory Card and it is set for erasure prevention. Change the position of the protect switch.
- The memory card is full. Erase images (□□ 121) or insert a new memory card.
- The power source is not properly connected, or the battery pack is exhausted or not properly attached (□□ 12-15, 147).
- The function cannot be used in that recording program (□□ 57).

**2 The PHOTO button doesn't work.**

- The memory card is not loaded (□ 102).
- You are using an SD Memory Card and it is set for erasure prevention. Change the position of the protect switch.
- The memory card is full. Erase images (□ 121) or insert a new memory card.
- You have reached the maximum file number. Set the file numbering to RESET through the menu (□ 105) and insert a new memory card.
- You are using an unformatted memory card. Format the card (□ 140).

**2 The image cannot be erased.**

- The image is protected (□ 120).
- You are using an SD Memory Card and it is set for erasure prevention. Change the position of the protect switch.

**Miscellaneous****Problem****2 The wireless controller doesn't work.****Cause and/or what to do about it**

- The remote sensor mode is set to OFF (OFF) in the menu (□ 49).
- The remote sensor modes of the wireless controller and the camcorder itself are different (□ 49).
- The batteries are dead or not inserted.

**2 The power indicator is flashing.**

- Check the screen displays (□ 160).

**2 The camcorder malfunctions.**

- External interference may cause the camcorder's microprocessor to malfunction temporarily. If random letters appear in the display or if normal operation is interrupted, remove and then replace the power source.

**2 The DV cable is connected correctly, but there's nothing in the display.**

- Remove the cable and then reconnect it or turn the power off and back on again.

**2 The camcorder becomes warm during use.**

- This is not a malfunction.

# The MV6i MC System Diagram (Availability differs from area to area)

E

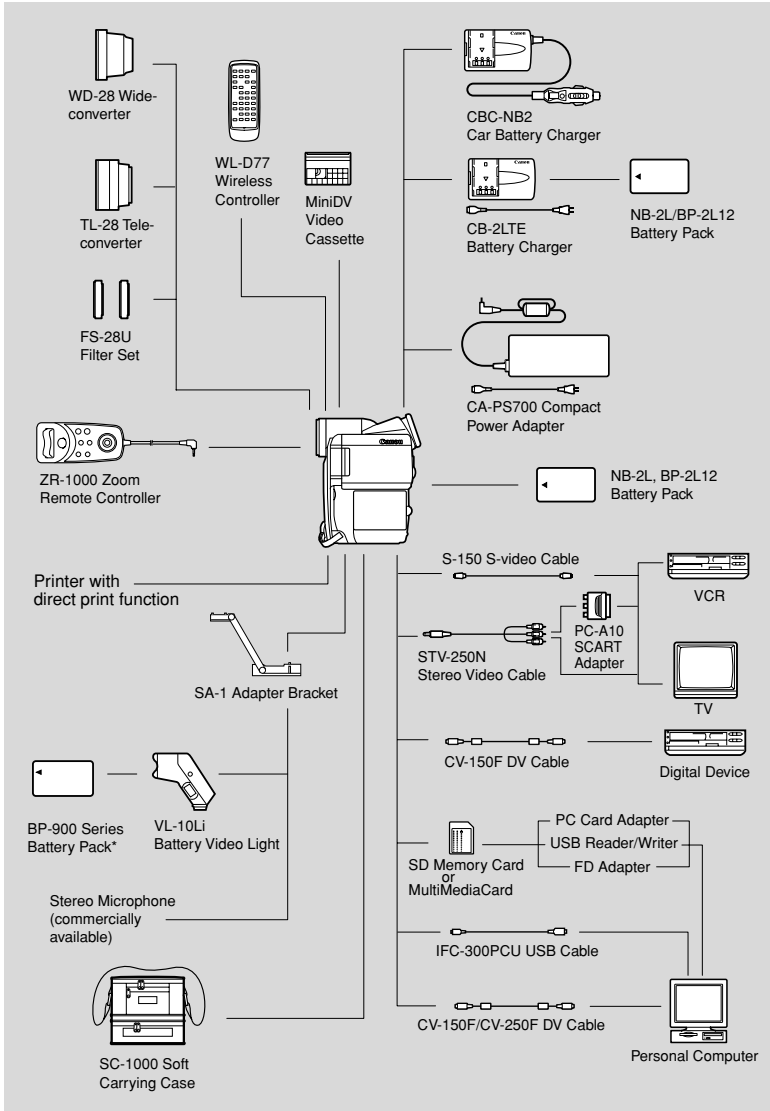

\* Charging with the CA-920 Compact Power Adapter or CH-910 Dual Battery Charger/Holder (both optional).

Additional Information

## Optional Accessories

E

### Battery Packs

The Battery Pack BP-2L12 can also be used with the MV6i MC.

NB-2L

BP-2L12

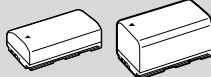

### CBC-NB2 Car Battery Charger

Connect the car battery cable to recharge battery packs on the move. The car battery cable plugs into your car's cigarette lighter socket and runs off a 12-24 V DC negative ground battery.

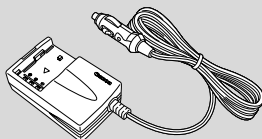

### TL-28 Tele-converter

This tele-converter lens increases the focal length of the camcorder lens by a factor of 1.7.

- The image stabilizer is not as effective as usual when the tele-converter is attached.
- With the tele-converter, the minimum focusing distance is 3 m; 3 cm on maximum wide angle.
- The light of the assist lamp in the Super Night and Low Light Plus mode will be blocked by the tele-converter.



### WD-28 Wide-converter

This lens decreases focal length by a factor of 0.7, giving you a wide perspective for indoor shots or panoramic views.

- The light of the assist lamp in the Super Night and Low Light Plus mode will be blocked by the wide-converter.



### FS-28U Filter Set

Neutral density and MC protector filters to help you take control of difficult lighting conditions.

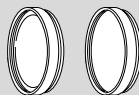

### VL-10Li Battery Video Light

This compact yet powerful video light can be used for both indoor and outdoor shooting.

- Use the BP-900 Series battery packs to power the light. Approximate usage times are as follows:  
BP-915 60 min. BP-930 120 min. BP-945 170 min.
- Charge the BP-900 Series battery packs with the CA-920 Compact Power Adapter.

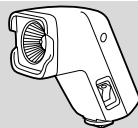

### Zoom Remote Controller ZR-1000

When this product is plugged into the LANC  terminal of a Canon camcorder, it is possible to control functions such as the start and stop of recording and the zoom and focusing functions while the camcorder is mounted on a tripod, without touching the camcorder body itself.

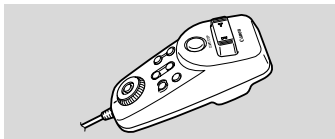

### SA-1 Adapter Bracket

Attaches a video light or microphone securely to the camera.

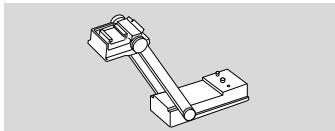

### SC-1000 Soft Carrying Case

A handy camcorder bag with padded compartments and plenty of space for accessories.



This mark identifies genuine Canon video accessories. When you use Canon video equipment, we recommend Canon-brand accessories or products bearing the same mark.

## Screen Displays

E

To display the date and time, press the DATA CODE button. See also p. 80.

Press the wireless controller's TV SCREEN button or turn TV SCREEN on through the menu to see the other displays on the TV screen. (The displays appear white on-screen.) They will not be added to any recordings you make with the camcorder.

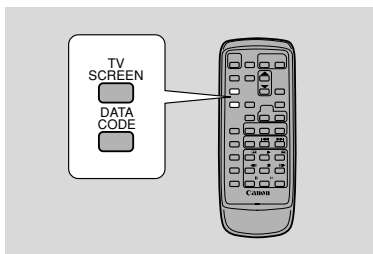

CAMERA

PLAY (VCR)

CARD CAMERA

CARD PLAY (VCR)

**MENU**

( 39)

▶ DISP. SET UP

▶▶ TV SCREEN...ON

**To turn TV SCREEN off, open the menu and select DISP. SET UP. Then select TV SCREEN, set it to OFF and close the menu.**

For instructions on how to hook the camcorder up to your TV, see p. 32.

### Turning off the LCD screen displays

You can turn off the displays to give you a clear screen for playback.

CAMERA

PLAY (VCR)

CARD CAMERA

CARD PLAY (VCR)

**MENU**

( 39)

▶ DISP. SET UP

▶▶ DISPLAYS...ON

**To turn the display off, open the menu and select DISP. SET UP. Then select DISPLAYS, set it to OFF <PLAYBK> and close the menu.**

- If you turn the displays off, the LCD screen will be completely blank (including connected TV screen), but the camcorder will continue to show warning/caution displays when necessary, and the data code appears in the display if it is set to ON.
- When operating the camcorder, the displays appear for 2 seconds. However, the displays do not disappear when displaying an index screen.

## Screen Displays during Basic Recording/Playback

 indicates flashing.

CAMERA mode (battery pack attached):

- Remote sensor mode and audio mode disappear after 4 seconds.

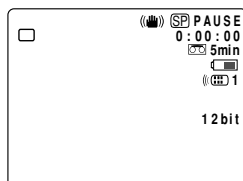

PLAY (VCR) mode:

- Remote sensor mode and volume bar disappear after 4 seconds.

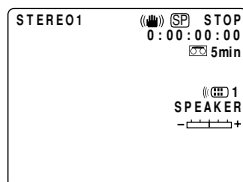

REC  
PAUSE  
STOP  
EJECT  
▶  
FF▶▶  
◀◀REW

- : Fast forward playback/rewind playback (□29)
- : ×2 playback (forward and reverse) (□30)
- : ×1 playback (forward and reverse) (□30)
- : Slow playback (forward and reverse) (□29)
- : Frame advance playback/frame reverse playback (□29)
- : Playback pause (forward and reverse) (□29)
- : Date search/photo search (□83)

RTN ▶▶/◀◀RTN

- : Zero set memory (forward and reverse) (□84)
- : AV insert editing (□93)
- : Audio dubbing (□96)

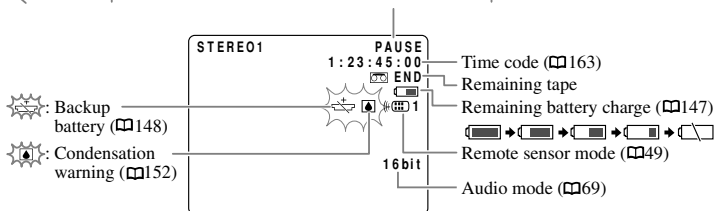

## Screen Displays during Advanced Recording/Playback

### CAMERA Mode

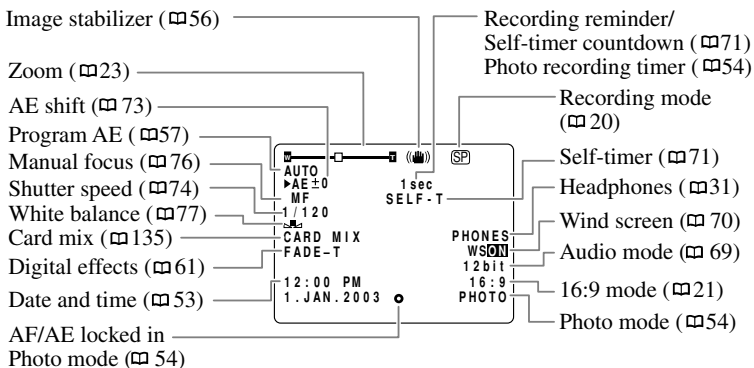

### PLAY (VCR) Mode

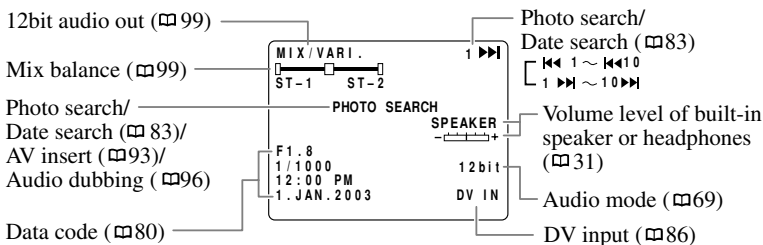

### CARD CAMERA Mode

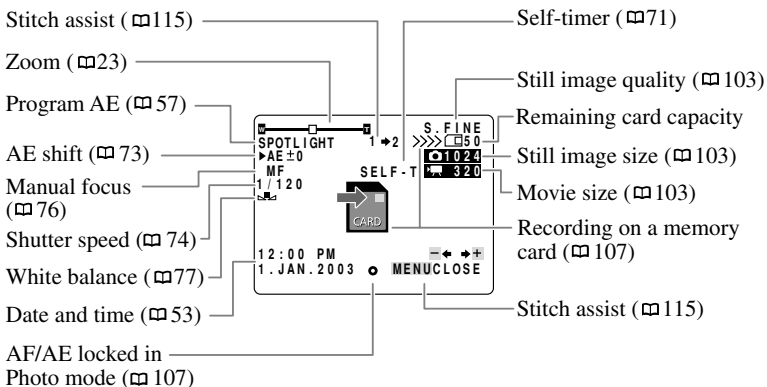

## CARD PLAY (VCR) Mode

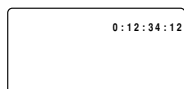
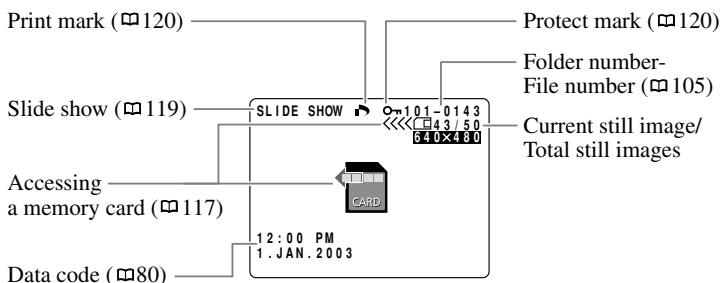

### Time Code

This records counter information, including hour, minute, second, and frame number on a special data code area on the tape itself. It is reset automatically when a new tape is loaded. In CAMERA mode, the frame number doesn't appear in the display.

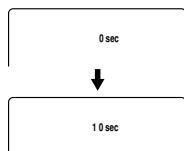

### Recording reminder

When you start recording, the camcorder counts from 0 sec to 10 sec. Shots which are shorter than ten seconds may be difficult to edit later. On the other hand, if you are not planning to edit the recording, remember that a shot which does not contain action should generally last no longer than 10 seconds.

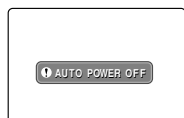

### “ⓘ AUTO POWER OFF”

The camcorder will turn itself off if you leave it in record pause mode for more than about 5 minutes. This display appears 20 seconds (approx.) before the camcorder turns off.

## Caution phrases

The camcorder displays various caution phrases — they appear for 4 seconds before disappearing.

Appears each time you turn the power on, until you set the time zone, date and time (  51).

SET THE TIME ZONE,  
DATE AND TIME

Appears when the battery pack is exhausted (  147).

CHANGE THE BATTERY PACK

Appears when the tape has reached the end.

TAPE END

Refer to p.17

THE TAPE IS SET FOR  
ERASURE PREVENTION

Appears when, during DV dubbing, the DV cable is disconnected or the power of the digital equipment connected to the camcorder is turned off.

CHECK THE DV INPUT

Refer to p.152

CONDENSATION  
HAS BEEN DETECTED

Appears as a warning to protect the tape and also when condensation is detected. Remove the tape as soon as possible after the camcorder has displayed the caution.

REMOVE THE CASSETTE

Refer to p.88

COPYRIGHT PROTECTED  
PLAYBACK IS RESTRICTED

Refer to p.88, p.89 or p.91

COPYRIGHT PROTECTED  
DUBBING RESTRICTED

Appears when you try to do audio dubbing or AV insert on a tape recorded in any mode other than SP mode (  93, 96).

CHECK THE CASSETTE  
[REC MODE]

Appears when you try to do audio dubbing on a tape recorded in 16-bit audio or 12-bit, 4-channel mode (  96).

CHECK THE CASSETTE  
[AUDIO MODE]

Appears when the camcorder detects a blank section of a tape during audio dubbing or AV insert (  93, 96).

CHECK THE CASSETTE  
[BLANK]



Appears immediately after you start recording, and the video heads are badly contaminated. Make sure to clean the video heads when this caution appears. ( 150)

HEADS DIRTY,  
USE CLEANING CASSETTE

Appears if you have tried to mark 201 or more images for printing, or if a mark file cannot be edited. ( 120)

PRINT MARK ERROR

### Memory card caution phrases

An error has occurred with the memory card. The camcorder cannot record or play back. A temporary card error is also possible. If **CARD ERROR** disappears after 4 seconds and  flashes red, turn the camcorder's power off and back on again, and remove and reinsert the card. If  flashes green, recording or playing back is possible.

CARD ERROR

No memory card is inserted in the camcorder. ( 102)

NO CARD

There are no images recorded on the memory card.

NO IMAGES

You are using an SD Memory Card and it is set for erasure prevention. Change the position of the protect switch.

THE CARD IS SET FOR  
ERASURE PREVENTION

There is no more remaining memory on the memory card. Change the card or erase images.

CARD FULL

Depending on the signal, some analogue images cannot be recorded on the memory card as still image.

THIS IMAGE CANNOT  
BE RECORDED

You have reached the maximum file or folder number. ( 105)

NAMING ERROR

Disconnect the USB cable, erase still images/movies until the memory card contains less than 900 images and reconnect the USB cable.

TOO MANY IMAGES  
DISCONNECT USB CABLE

The image has been recorded in an incompatible JPEG format or other format that the camcorder can not play back, or the image data has been damaged.

UNIDENTIFIABLE  
IMAGE

## Direct Print Related Messages

| Message                    | Explanation   |
|----------------------------|---|
| No Paper                   | Paper cassette is not correctly inserted or is out of paper.  |
| Paper Jam                  | The paper jammed during printing.   |
| No Ink                     | The ink cartridge is not inserted or is out of ink.   |
| Ink Cassette Error         | There is a problem with the ink cassette.   |
| Communication Error        | The printer is experiencing a data transmission error.  |
| Could not print X images   | You attempted to use the print mark settings to print X images that were made with another camcorder, have a different format or were edited on a computer.   |
| Cannot Print!              | You attempted to print an image that was made with another camcorder, has a different format, or was edited on a computer.  |
| Set print mark             | You attempted to print an image from the CARD PLAY (VCR) menu [➡️▶️PRINT] without having set the print mark.  |
| Readjust trimming          | You changed the print style after you set the trimming settings.  |
| Paper has been changed     | Paper size has been changed between print setting and start of printing.  |
| Paper and ink do not match | The ink cannot be used with the selected paper type.  |
| Printer in use             | The printer is printing from a computer or a memory card inserted into the printer. It automatically starts printing from the camcorder when current prints are complete.   |
| Printer warming up         | Printer is warming up. The printer automatically starts printing when it is ready.  |
| No printhead               | No print head is installed in the printer.  |
| Printer cover open         | Printer cover is open. Close the printer cover securely.  |
| Media type error           | Wrong paper. Cancel printing and set the paper you chose in the print settings menu.  |
| Paper lever error          | Paper lever error occurred. Adjust the paper selection lever to the proper position.  |
| Low ink level              | The ink tank needs to be replaced soon. Prepare a new ink tank. If you select [Continue] in the error screen, you can restart printing.   |
| Waste tank full            | Waste tank is full. You can restart printing by pressing the RESUME/CANCEL button on the Bubble Jet Printer. Request replacement of the waste tank at the shop where you purchased the printer or the nearest Canon customer support center listed in the Bubble Jet Quick Start Guide. |
| Printer error              | Turn off the printer and turn it back on. If the error persists, consult the nearest Canon customer support center listed in the Bubble Jet Quick Start Guide.  |

# Specifications

## MV6i MC

**Power Supply (rated):** 7.4 V DC

**Power Consumption (while recording with the AF turned on):**

3.1 W (Using viewfinder),  
4.1 W (Using LCD screen)

**Television system:**

CCIR standard (625 lines, 50 fields)  
PAL colour signal

**Video recording system:**

2 rotary heads, helical scanning DV system (Consumer digital VCR SD system)

Digital component recording

**Audio recording system:**

Tape: PCM digital sound: 16 bit (48 kHz/2 ch); 12 bit (32 kHz/4 ch)  
Card: ADPCM digital sound: 16 bit (16 kHz/1 ch), 4 bit

**Image sensor:**

1/6" CCD (charge coupled device), approx. 800,000 pixels (card: 740,000 effective pixels, tape: 420,000 effective pixels)

**Tape format:**

Videocassettes bearing the <sup>Mini</sup> DV mark.

**Tape speed:**

SP: 18.83 mm/s,  
LP: 12.57 mm/s

**Maximum recording time**

(with an 80 min. cassette):

SP: 80 min., LP: 120 min.,

**Fast forward/rewind time:**

Approx. 2 min. 20 sec.  
(with a 60 min. cassette)

**Lens:**

F1.8–2.3, 10× power zoom, f=2.5–25 mm (card: 7.5× power zoom, f=3.3 – 25 mm)

**Focusing system:**

TTL autofocus, manual focusing possible

**Minimum focusing distance:**

1 m (1 cm on maximum wide angle)

**Maximum shutter speed:** 1/2,000 sec.

(1/250 sec. when using a memory card)

**Minimum illumination:**

2.4 lx (using the Night program in CAMERA mode)

**Recommended illumination:**

More than 100 lx

**Filter diameter:** 28 mm

**Viewfinder:**

0.5 in, TFT colour LCD,  
approx. 113,000 pixels

**LCD screen:**

2 in measured diagonally,  
TFT colour, approx. 130,000 pixels

**Microphone:**

Stereo electret condenser microphone

**Recording media:**

SD Memory Card, MultiMediaCard

**Number of recording pixels:**

Still image: 1024 × 768, 640 × 480 pixels  
Movie: 320 × 240 pixels (approx. 10 sec.)\*, 160 × 120 pixels (approx. 30 sec.)\*

\* The figures in brackets represent the maximum length of one movie clip.

**Image format:**

Design rule for Camera File system (DCF), Exif 2.2 compliant\*  
Digital Print Order Format (DPOF) compliant (only images marked for printing)

\* This camcorder supports Exif 2.2 (also called "Exif Print"). Exif Print is a standard for enhancing the communication between camcorders and printers. By connecting to an Exif Print-compliant printer, the camcorder's image data at the time of shooting is used and optimized, yielding extremely high quality prints.

**File format:** Still Image: JPEG

(compression mode: Superfine, Fine, Normal)

Movie: Motion JPEG

**Estimated SD Memory Card SDC-8M capacities (approx.):**

1024 × 768: Superfine 14 images/Fine 20 images/Normal 39 images  
640 × 480: Superfine 35 images/Fine 52 images/Normal 86 images

- The actual number you can record varies depending on the images. Remember that the sample images recorded on the supplied SD Memory Card are included in the total number.

**USB terminal:** mini-B**DV Terminal:**

Special 4-pin connector  
(conforms to IEEE1394)

**AV/headphones terminal:**

ø 3.5 mm minijack

Audio input: -10 dBV/at least 40 kohms,  
(L, R), unbalanced

output: -10 dBV (47 kohm load)/  
less than 3 kohms,  
unbalanced

Video: 1 V<sub>p-p</sub>/75 ohms unbalanced

**S-video terminal:**

1 V<sub>p-p</sub> (Y signal), 0.3 V<sub>p-p</sub> (C signal)

**MIC terminal input:** ø 3.5 mm stereo minijack, -57 dBV (with 600 ohm mic)/ at least 5 kohms**LANC terminal:** ø 2.5 mm mini minijack**Operating temperature range:**

0°-40°C

**Dimensions:** 50 × 111 × 89 mm**Weight:** 380 g**NB-2L Battery Pack****Battery type:** Rechargeable lithium ion battery**Rated voltage:** 7.4 V DC**Operating temperature:** 0°-40°C**Battery capacity:** 570 mAh**Dimensions:** 33.3 × 45.2 × 16.2 mm**Weight:** 40 g

16:9, 21

## A

Abroad, Using the Camcorder, 151  
Accessories, 7, 158  
AE Programs, 57  
AE Shift, 73  
Analog line-in, 89  
Analog-digital converter, 91  
Audio Dubbing, 96  
Audio Mix, 99  
Audio Mode, 69  
Audio Output, 99  
Audio/Video Terminal, 32  
Auto, 58  
AV Insert, 93

## B

Backup Battery, 148  
Battery Charger, 14  
Battery Pack, 14-15, 146  
Beep, 22  
Brightness, 26

## C

Charging the Battery Pack, 14, 146  
Cleaning the Camcorder, 150  
Combining Images, 135  
Condensation, 152  
Connecting to a PC, 101, 141  
Connection to TV or VCR, 32  
Copying from Memory Card to Tape, 139  
Copying from Tape to Memory Card, 138

## D

Data Code, 80  
Date and Time, 53  
Date Search, 83  
Demo mode, 22  
Digital Effects, 61  
Digital Zoom, 23  
Direct Print Function, 128  
DV Dubbing, 86

## E

Easy Recording, 58  
Editing to a VCR, 85  
Effects, 64  
Erasing Still Images, 121, 126  
External Microphone, 69, 96

## F

Faders, 62  
Fast Forward, 28  
File Numbers, 105  
Focusing, 76  
Formatting a Memory Card, 140

## H

Head Cleaning, 150  
Headphones, 31

## I

Image Quality, 103  
Image Stabilizer, 56  
Index Screen, 119

## L

LANC, 85  
LCD Screen, 25  
Lens Cap, 145  
Loading Cassettes, 16  
Low Light, 59  
Low Light Plus, 60  
LP Mode, 20

## M

Maintenance, 149  
Making Better Videos, 36  
Menus, 39  
Microphone, 69, 96  
Multi-Image Screen, 67

## N

Night, 60

## O

Optional Accessories, 158

## E

## P

- Pause, Record, 18
- PC Connection, 101, 141
- Photo Search, 83
- Playback Connection, 32
- Playback Pause, 29
- Playing Back a Tape, 28
- Playing Back Memory Card, 117
- Portrait, 59
- Power Adapter, 12-14
- Powering Your Camcorder, 12
- Pre-Marked Position, 84
- Preparing the Camcorder, 145
- Preventing Accidental Erasure, 120, 123
- Print Mark, 120, 124
- Problems, 153
- Protect, 120, 123

## R

- Record Pause Mode, 18
- Record Review, 38
- Record Search, 38
- Recording Movies on a Memory Card, 112
- Recording Movies onto a Tape, 18
- Recording Programs, 57
- Recording Still Images on a Memory Card, 107
- Recording Still Images onto a Tape, 54
- Remote Control, 48
- Remote Sensor, 48-49
- Rewind, 28

## S

- S1 video terminal, 34
- Sample images, 143
- Sand & Snow, 59
- Screen Displays, 160
- SD Memory Card, 102, 142
- Self-Timer, 71
- Shutter Sound, 106
- Shutter Speed, 74
- Slide Show, 119

- SP Mode, 20
- Speaker, 31
- Sports, 59
- Spotlight, 59
- Still Images, 54, 107
- Storage, 150
- Super Night, 60
- S-video, 34
- System Diagram, 157

## T

- Tape Protection, 17
- Telephoto, 23
- Time Code, 163
- Time Zone, 51
- Tripod, 36
- Troubleshooting, 153
- TV, 32, 160

## U

- USB terminal, 141

## V

- VCR, 32
- Video Heads, 150
- Videocassettes, 16
- Viewfinder, 145

## W

- White Balance, 77
- White LED, 60
- Wide screen TV, 21
- Wide-angle, 23
- Wind Screen, 70
- Wireless Controller, 48

## Z

- Zero Set Memory, 84
- Zooming, 23

# Canon

## **CANON INC.**

### **Canon Europa N.V.**

P.O. Box 2262, 1180 EG Amstelveen, the Netherlands

### **Canon UK Ltd.**

Ribcon Way  
Luton Bedfordshire LU4 9UR  
Telephone 0870-241-2161

### **Canon Australia Pty. Ltd**

1 Thomas Holt Drive, North Ryde, N.S.W. 2113, Australia  
Telephone 805-2000, Fax 887-4484

### **Canon New Zealand Ltd**

Akoranga Business Park, Akoranga Drive, Northcote, Auckland, New Zealand  
Telephone 489-0300, Fax 489-0380

### **Canon Singapore Pte. Ltd**

79 Anson Road #09-01/06, Singapore 079906  
Telephone (65)-532-4400, Fax (65)-221-2939

### **Canon Hongkong Company Ltd**

9/F, The Hong Kong Club Building, 3A Chater Road, Central, Hong Kong

### **Canon Latin America, Inc.**

Sales & Enquiries: 703 Waterford Way Suite 400 Miami, FL 33126 USA



Printed on 100% reused paper.