

Format A6

Fix 1775 UK KURTZ DESIGN 21.02.05

FIX_1775_MN_S1 Seite 1 Montag, 21. Februar 2005 11:00 11

BRAUN

FreeControl

1775



Type 5729

www.braun.com/register



Braun Infoline

- | | | | |
|------------|------------|--------------|---|
| Deutsch | 6, 48, 55 | (D) | Haben Sie Fragen zu diesem Produkt? |
| English | 9, 48, 55 | (A) | Rufen Sie an (gebührenfrei):
00 800 27 28 64 63
00 800 BRAUNINFOLINE |
| Français | 12, 49, 55 | (CH) | 08 44 - 88 40 10 |
| Español | 15, 49, 55 | (E) | Servicio al consumidor para España:
901-11 61 84 |
| Português | 18, 50, 55 | (P) | Serviço ao Consumidor para Portugal:
808 20 00 33 |
| Italiano | 21, 51, 55 | (I) | Servizio consumatori:
(02) 6 67 86 23 |
| Nederlands | 24, 51, 55 | (NL) | Heeft u vragen over dit product?
Bel Braun Consumenten-infolijn:
0 800-445 53 88 |
| Dansk | 27, 52, 55 | (B) | Vous avez des questions sur ce produit ?
Appelez Braun Belgique
(02) 711 92 11 |
| Norsk | 30, 52, 55 | (DK) | Har du spørgsmål om produktet? Så ring
70 15 00 13 |
| Svenska | 33, 53, 55 | (N) | Spørsmål om dette produktet? Ring
22 63 00 93 |
| Suomi | 36, 53, 55 | (S) | Frågor om apparaten? Ring Kundservice
020 - 21 33 21 |
| Türkçe | 39, 55 | (FIN) | Onko Sinulla kysyttävää tuotteesta? Soita
0203 77877 |
| Ελληνικά | 42, 54, 55 | (TR) | Müşteri Hizmetleri Merkezi:
0212 - 473 75 85 |

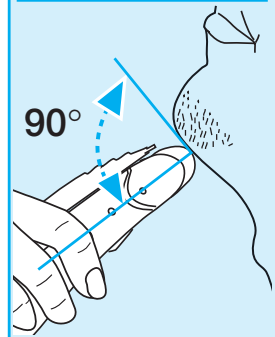
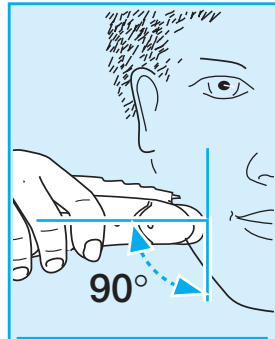
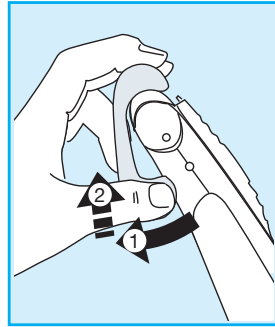

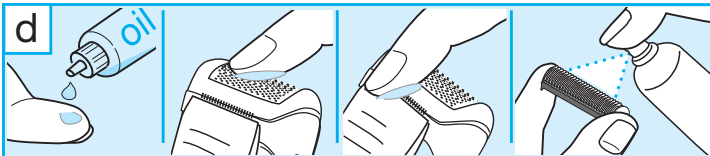
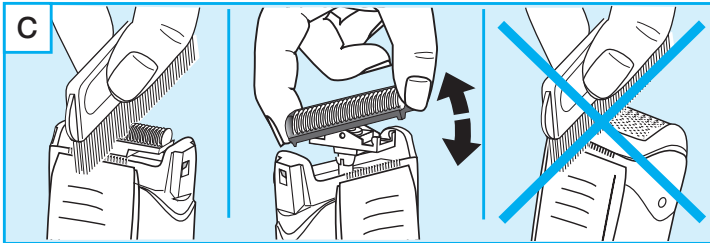
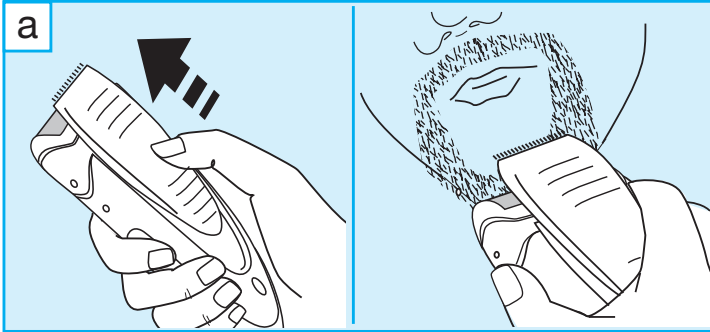

Deutsch

Unsere Produkte werden hergestellt, um höchste Ansprüche an Qualität, Funktionalität und Design zu erfüllen. Wir wünschen Ihnen mit Ihrem neuen Braun Gerät viel Freude.

Achtung

Der Rasierer ist mit einem Spezialkabel mit integriertem Netzteil für Sicherheitskleinspannung ausgestattet. Es dürfen weder Teile ausgetauscht noch Veränderungen vorgenommen werden, da sonst Stromschlaggefahr besteht.

Beschreibung

- 1 Schutzkappe
- 2 Scherfolie
- 3 Klingenblock
- 4 Trimmer (Langhaarschneider)
- 5 Ladekontroll-Leuchte
- 6 Ein-/Ausschalter
- 7 Spezialkabel

Aufladen des Rasierers

Die ideale Umgebungstemperatur für das Laden liegt zwischen 15 °C und 35 °C.

- Den ausgeschalteten Rasierer mit dem Spezialkabel (7) ans Netz anschließen.
- Bei der Erstladung den Rasierer mindestens 4 Stunden ununterbrochen laden.
Die Ladekontroll-Leuchte (5) zeigt an, dass der Rasierer geladen wird. Sind die Akkus voll geladen, blinkt die Ladekontroll-Leuchte nur noch gelegentlich beim Nachladen.
- Voll geladen kann der Rasierer je nach Bartstärke ca. 30 Minuten kabellos betrieben werden.
- Verwenden Sie den Rasierer kabellos, bis die Akkus leer sind. Danach wieder voll aufladen. Nachfolgende Ladevorgänge dauern ca. 1 Stunde.
- Die maximale Akku-Kapazität wird erst nach mehreren Lade-/Entladevorgängen erreicht.
- Wenn die Akkus leer sind, können Sie das Gerät auch direkt über das Spezialkabel vom Netz betreiben.

Rasieren

Zuerst Schutzkappe (1) abnehmen und den Rasierer mit dem Ein-/Aus-schalter (6) einschalten. Der bewegliche Scherfolienrahmen passt sich automatisch der Gesichtsform an und sorgt für eine gründliche und sanfte Rasur.

Wenn Sie sich einige Tage nicht rasiert haben, können Sie den Trimmer (4) verwenden, um längere Haare zunächst vorzukürzen und dann mit der Scherfolie gründlich auszurazieren.

Trimmen

Durch Ausfahren können Sie den Trimmer zuschalten (a). Der Trimmer ist nicht nur für das großflächige Trimmen konzipiert, sondern auch ideal für Formen und Teilen von Koteletten, Oberlippen- und Teilbärten.

Häufiger Einsatz des Trimmers kann die Akku-Kapazität herabsetzen.

Tipps für eine optimale Rasur

- Wir empfehlen, vor dem Waschen zu rasieren, da die Haut nach dem Waschen leicht aufgequollen ist.
- Rasierer im rechten Winkel (90°) zur Haut halten. Haut straffen und gegen die Bartwuchsrichtung rasieren.
- Um 100% der Rasierleistung zu erhalten, ersetzen Sie die Scherfolie und den Klingenblock spätestens alle 18 Monate oder sobald sie Verschleißerscheinungen zeigen.

Reinigung



Dieses Gerät ist geeignet zur Reinigung unter fließendem Wasser. Achtung: Das handgehaltene Teil ist von der Anschlussleitung zu trennen, bevor es im Wasser gereinigt wird.

Durch regelmäßiges Reinigen erhalten Sie eine optimale Rasierleistung. So können Sie den Rasierkopf nach jeder Rasur einfach und schnell unter fließendem Wasser reinigen:

- Rasierer einschalten (kabellos) und den Rasierkopf unter heißes, fließendes Wasser halten (b). Gelegentlich Seife verwenden (Flüssigseife auf natürlicher Basis ohne Scheuermittel). Den Schaum gut abspülen und den Rasierer noch einige Sekunden laufen lassen.
- Dann den Rasierer ausschalten, Scherfolie und Klingenblock abnehmen und Teile trocknen lassen.



Alternativ können Sie den Rasierer mit der mitgelieferten Bürste reinigen (c):

- Rasierer ausschalten und die Scherfolie abnehmen.
- Mit der Bürste den Klingenblock und den inneren Teil des Rasierkopfes reinigen. Die Scherfolie darf nicht mit der Bürste gereinigt werden.

So halten Sie Ihren Rasierer in Bestform

Etwa alle vier Wochen den Klingenblock mit Braun Reinigungsmitteln reinigen. Verteilen Sie etwas Leichtmaschinenöl auf der Scherfolie und dem Trimmer (d).

Scherteile-Wechsel

Um 100% der Rasierleistung zu erhalten, wechseln Sie Scherfolie und Klingenblock spätestens alle 18 Monate oder sobald sie Verschleißerscheinungen zeigen. Für eine gründlichere Rasur mit weniger Hautreizung sollten Sie beide Teile gleichzeitig auswechseln.
(Scherfolie und Klingenblock: 1000 Series)

Akku-Pflege

Um die maximale Kapazität der Akkus zu erhalten, sollte der Rasierer ca. alle sechs Monate durch Gebrauch vollständig entladen werden. Danach den Rasierer wieder voll aufladen. Setzen Sie das Gerät nicht für längere Zeit Temperaturen über 50°C aus.

Umweltschutz

Dieses Gerät enthält Nickel-Hydrid-Akkus. Aus Umweltschutzgründen darf das Gerät am Ende seiner Lebensdauer nicht mit dem Hausmüll entsorgt werden.

Öffnen Sie das Gehäuse wie auf Seite 46 dargestellt, nehmen Sie die Akkus heraus und geben Sie sie gemäß nationaler oder lokaler Bestimmungen beim Handel oder entsprechenden Sammelstellen ab.

Änderungen vorbehalten.

Dieses Gerät entspricht den EU-Richtlinien EMV 89/336/EWG und Niederspannung 73/23/EWG.



Elektrische Angaben siehe Bedruckung auf dem Spezialkabel.

Bitte führen Sie das Gerät am Ende seiner Lebensdauer den zur Verfügung stehenden Rückgabe- und Sammelsystemen zu.



English

Our products are designed to meet the highest standards of quality, functionality and design. We hope you entirely enjoy your new Braun shaver.

Warning

Your shaver is provided with a special cord set with integrated Safety Extra Low Voltage power supply. Do not exchange or manipulate any part of it. Otherwise there is a risk of electric shock.

Description

- 1 Foil protection cap
- 2 Shaver foil
- 3 Cutter block
- 4 Long hair trimmer
- 5 Charging light
- 6 On/off switch
- 7 Special cord set

Charging

The best environmental temperature for charging is between 15 °C and 35 °C.

- Using the special cord set, connect the shaver to an electrical outlet with the motor switched off.
- When charging for the first time, leave the shaver to charge continuously for 4 hours. The charging light (5) shows that the shaver is being charged. When the battery is fully charged, the charging light intermittently blinks on and off. This indicates that the battery maintains its full capacity.
- A full charge provides up to 30 minutes of cordless shaving time depending on your beard growth.
- Once the shaver is completely charged, discharge the shaver through normal use. Then recharge to full capacity. Subsequent charges will take about 1 hour.
- Maximum battery capacity will only be reached after several charging/discharging cycles.
- If the rechargeable batteries are discharged, you may also shave by connecting the shaver to an electrical outlet via the special cord set.

Shaving

Remove the foil protection cap (1). Activate the on/off switch (6). The floating foil frame automatically adapts to your skin surface for a close, smooth shave.

For pre-shaving after a few days of not having shaved, use the long hair trimmer (4) to pre-cut long hairs. For a close, smooth shave, finish with the foil.

Trimming

Push out the long hair trimmer (a). It allows controlled trimming of moustache and sideburns. It evenly cuts and trims larger areas: ideal for shaping sideburns, moustaches and partial short beards.

Frequent use of the long hair trimmer may reduce the battery capacity.

Tips for the perfect shave

- We recommend that you shave before washing, as the skin tends to be slightly swollen after washing.
- Hold the shaver at right angles (90°) to the skin. Stretch the skin and shave against the direction of beard growth.
- To maintain 100% shaving performance, replace your foil and cutter block at least every 18 months or when worn.

Cleaning



This appliance is suitable for cleaning under an open water tap.

Warning: Detach the hand-held part from the power supply before cleaning it in water.

Regular cleaning ensures better shaving performance. Rinsing the shaving head after each shave under running water is an easy and fast way to keep it clean:

- Switch the shaver on (cordless) and rinse the shaving head under hot running water (b). A natural based soap may also be used provided it contains no particles or abrasive substances. Rinse off all foam and let the shaver run for a few more seconds.
- Next, switch off the shaver, remove the shaver foil and the cutter block. Then leave the disassembled shaving parts to dry.

Alternatively, you may clean the shaver using the brush provided (c):

- Switch off the shaver. Remove the shaver foil.
- Using the brush, clean the cutter block and the inner area of the shaver head. However, do not clean the shaver foil with the brush as this may damage the foil.

Keeping your shaver in top shape

About every four weeks, clean the cutter block with Braun cleaning agents. Put a drop of light machine oil onto the long hair trimmer and the shaver foil (d).

Replacing the shaving parts

To maintain 100% shaving performance, replace your foil and cutter block at least every 18 months or when worn. Change both parts at the same time for a closer shave with less skin irritation.
(Shaver foil and cutter block: 1000 series)

Preserving the batteries

In order to maintain the optimum capacity of the rechargeable batteries, the shaver has to be fully discharged (by shaving) every 6 months approximately. Then recharge the shaver to full capacity. Do not expose the shaver to temperatures higher than 50 °C for extended periods of time.

Environmental notice

This appliance is provided with nickel-hydride rechargeable batteries. To protect the environment, do not dispose of this appliance in the household waste at the end of its useful life. Open the housing as shown on page 46, remove and dispose of the batteries at your retail store or at appropriate collection sites according to national or local regulations.

Subject to change without notice.

This product conforms to the European Directives EMC 89/336/EEC and Low Voltage 73/23/EEC.



Electric specifications see printing on the special cord set.

At the end of the product's useful life, please dispose of it at appropriate collection points provided in your country.





Française

Nos produits sont conçus pour satisfaire aux plus hautes exigences en matière de qualité, fonctionnalité et design. Nous espérons que vous serez pleinement satisfait de votre nouveau rasoir Braun.

Avertissement

Le rasoir est livré avec un système d'adaptateur basse tension. Il ne faut donc remplacer ni manipuler aucun élément de l'appareil. Sinon, il y a risque d'électrocution.

Description

- 1 Capot de protection de la grille
- 2 Grille de rasage
- 3 Bloc-couteaux
- 4 Tondeuse rétractable
- 5 Témoin lumineux de charge
- 6 Bouton marche/arrêt
- 7 Cable d'alimentation



Mise en charge du rasoir

La température idéale pour la mise en charge est comprise entre 15°C et 35°C.

- Utilisez le cordon d'alimentation, branchez le rasoir sur le secteur en veillant à ce que l'appareil soit en position arrêt.
- Lors de la première mise en charge, laissez l'appareil branché pendant au moins 4 heures. Le témoin de charge (5) vous indique que le rasoir est en cours de charge. Lorsque la batterie est complètement pleine, ce même témoin de charge se met à clignoter.
- Une pleine charge procure jusqu'à 30 minutes de rasage sans fil en fonction du type de barbe.
- Une fois que le rasoir est complètement chargé, déchargez-le en l'utilisant normalement sans le cordon. Rechargez-le ensuite. Le temps de charge supplémentaire prendra environ une heure.
- La capacité maximum de batterie sera atteinte seulement après plusieurs cycles de charge et de décharge.
- Lorsque la batterie est déchargée, vous pouvez également vous raser avec le rasoir branché sur le secteur grâce au cordon d'alimentation.



Rasage

Retirez le capot de protection de la grille (1). Appuyez sur le bouton marche/

12

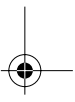
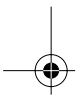



arrêt pour mettre en marche le rasoir. La grille flottante s'adapte automatiquement à votre surface de peau pour un rasage précis et doux.

Pour vous pré-raser lorsque vous ne vous êtes pas rasé depuis quelques temps, utilisez la tondeuse rétractable (4) et ce afin de pré-coupez les poils les plus longs.

Tondeuse

Poussez la tondeuse rétractable vers l'avant (a). Cela permet de mieux maîtriser la tonte de votre barbe ou de vos pattes. L'appareil peut éventuellement couper ou tondre des zones plus larges : idéale pour dessiner les contours de barbes, de moustaches ou les barbes de 3 jours.

Une utilisation fréquente de la tondeuse rétractable pourrait réduire la capacité de la batterie.

Les astuces pour un rasage parfait :

- Nous vous recommandons de vous raser avant la toilette faciale car la peau a tendance à légèrement gonfler lorsqu'elle est humide.
- Tenez le rasoir perpendiculairement (90°) à votre visage.
- Pour conserver une performance de rasage optimale, nous vous recommandons de remplacer la grille et le bloc-couteaux de votre rasoir tous les 18 mois.

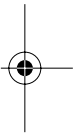
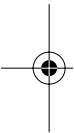

Nettoyage



Vous pouvez nettoyer votre appareil en le passant sous l'eau. Attention : Il faut absolument retirer le cordon d'alimentation de l'appareil avant de le mettre sous l'eau.

Un nettoyage régulier vous assure de meilleures performances de rasage. Le fait de passer la tête de rasage sous l'eau courante après chaque utilisation est un moyen facile et rapide de garder votre rasoir propre.

- Allumer votre rasoir (sans le cordon d'alimentation) et rincez-le à l'eau chaude (b). Vous pouvez aussi utiliser un savon à base d'ingrédients naturels qui ne contient pas de particules, ni de substances abrasives.
- Puis éteignez votre appareil, retirez la grille de rasage ainsi que le bloc-couteaux. Enfin laissez sécher les parties que vous venez de désassembler.

Vous pouvez aussi nettoyer votre rasoir en utilisant la brosse de nettoyage qui a été fournie avec votre appareil (c).

- Eteignez votre rasoir. Retirez la grille de rasage.

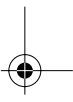
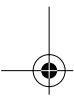



- En vous servant de la brosse, nettoyez le bloc-couteaux ainsi que la partie qui se trouve en dessous de la tête. Cependant, ne nettoyez pas la grille de rasage avec la brosse, celle-ci risquerait de l'endommager.

Garder votre rasoir performant

Environ toutes les 4 semaines, nettoyez le bloc-couteaux avec du liquide nettoyant Braun. Versez une goutte d'huile de machine à coudre sur la tondeuse rétractable et sur la grille du rasoir.

Remplacement des pièces de rasage

La grille et le bloc-couteaux de votre rasoir sont des pièces de précision qui, dans le temps, sont amenées à s'user. En les remplaçant tous les 18 mois, cela augmente l'efficacité de rasage. Veillez à changer le bloc-couteaux et la grille dans le même temps et ce pour obtenir un rasage précis et éviter les irritations de la peau. (Référence de la grille et du bloc-couteaux : série 1000)

Entretien de la batterie

Afin de conserver la capacité maximum de la batterie, le rasoir doit être complètement déchargé (en se rasant) environ tous les 6 mois. Puis rechargez le rasoir à sa pleine capacité. Ne pas exposer le rasoir à une température au dessus de 50°C pendant de longues périodes.

Respect de l'environnement

Cet appareil est équipé des batteries rechargeables nickel-hydrure. Afin de protéger l'environnement, ne jetez jamais l'appareil dans les ordures à la fin de sa durée de vie.

Ouvrez le boîtier comme indiqué, retirez la batterie et remettez-la à votre Centre-Service Agréé Braun ou déposez-la dans des sites de récupération appropriés, conformément aux réglementations locales ou nationales.

Sujet à toute modification sans préavis.

Cet appareil est conforme aux normes Européennes fixées par les Directives 89/336/EEC et la directive Basse Tension 73/23/EEC.



Voir les spécifications électriques mentionnées sur l'adaptateur basse tension.

Une fois le produit en fin de vie, veuillez le déposer dans un point de recyclage approprié.





Español

Nuestros productos están desarrollados para alcanzar los más altos estándares de calidad, funcionalidad y diseño. Esperamos que su nueva afeitadora Braun satisfaga por completo sus necesidades.

Aviso

Su afeitadora está provista de una conexión especial segura mediante un transformador integrado de bajo voltaje. Por lo tanto, no debe cambiar o manipular ninguna parte. De lo contrario corre el riesgo de sufrir una descarga eléctrica.

Descripción

- 1 Capuchón protector de lámina
- 2 Lámina
- 3 Bloque de Cuchillas
- 4 Corta patillas
- 5 Luz de carga
- 6 Interruptor encendido/apagado
- 7 Cable especial de conexión

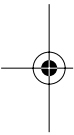

Proceso de Carga

La temperatura ambiente ideal para el proceso de carga es de 15 °C a 35 °C.

- Utilice el cable especial de conexión y conecte la afeitadora a la red eléctrica con la maquina apagada.
- Para la primera carga, cárguela al menos durante 4 horas. La luz de carga (5) indicará que la afeitadora se está cargando. Una vez que la afeitadora se haya cargado completamente la luz de carga parpadeará. Esto indicará que la batería está a su máxima capacidad.
- Tendrá unos 30 minutos de afeitado sin cable, dependiendo de su tipo de barba.
- La capacidad máxima de la batería se alcanzará únicamente después de varias cargas y descargas.
- Cuando la batería está totalmente descargada, puede afeitarse con la afeitadora conectada a la red con el cable especial de conexión.

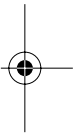

Afeitado

Retire el capuchón protector de lámina (1). Encienda la afeitadora presionando el interruptor encendido/apagado (6). El cabezal flotante de su afeitadora se ajustará perfectamente a los contornos de la cara para un afeitado apurado y suave.

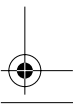
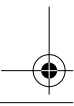

Para un pre-afeitado en caso de tener barba de varios días, utilice el corta patillas (4) para cortar los pelos largos. Para un afeitado apurado y suave utilice, a continuación, la lámina.

Cortapatillas

Deslice el corta patillas (a). Con él conseguirá un mayor control recortando bigotes y patillas. Incluso corta y perfila grandes áreas: ideal para dar forma a las patillas, bigotes y barbas medias y cortas.

El uso frecuente del corta patillas puede reducir la capacidad de la batería.

Consejos para un afeitado perfecto

- Recomendamos afeitarse antes de lavarse la cara, ya que la piel tiende a hincharse ligeramente después de lavarse.
- Mantenga la afeitadora en un ángulo recto (90°) con la piel. Estire la piel y deslice la afeitadora en la dirección contraria al crecimiento de la barba.
- Para mantener su afeitadora rindiendo al 100%, recomendamos reemplazar la lámina y el bloque de cuchillas cada 18 meses, o cuando se hayan deteriorado.

Limpieza



Limpiable con agua bajo el grifo.

Precaución: desconecte el aparato de la corriente antes de limpiarlo con agua

Una limpieza regular asegura un mejor rendimiento en el afeitado. Ponga el cabezal de la afeitadora bajo el grifo de agua caliente después de cada afeitado para mantenerlo limpio de forma fácil y rápida:

- Encienda la afeitadora (sin el cable conectado a red) y enjuague el cabezal bajo el grifo con agua caliente (b). Para una limpieza mas completa ocasionalmente puede usar un jabón natural, sin sustancias abrasivas. Aclare la afeitadora directamente bajo el grifo durante unos segundos para eliminar los restos de espuma.
- A continuación debe apagar la afeitadora y presionar los botones de extracción de lámina para sacar ésta y retirar el bloque de cuchillas. Deje estas piezas un tiempo secarse antes de volver a colocarlas.

Como alternativa, también puede limpiar su afeitadora con el cepillo que le facilitamos (b) :

- Apague la afeitadora y extraiga la lámina.

- Use el cepillo, para limpiar las cuchillas y alrededor de ellas por la zona interior del cabezal. No debe limpiar la lámina con el cepillo porque podría dañarse.

Mantenga su afeitadora en óptimo estado

Cada cuatro semanas limpie el bloque de cuchillas con los productos limpiadores de Braun. Ponga una gota de lubricante en el corta patillas y en la lámina (d).

Cambio de lamina y cuchilla

Para asegurar un rendimiento 100% de su afeitadora, conviene sustituir la lámina y el bloque de cuchillas cada 18 meses, o cuando se encuentren gastados. Sustituya las dos piezas al mismo tiempo para asegurarse un apurado óptimo con la menor irritación para la piel.
(Recambio de lámina y cuchilla: 1000 series)

Mantenimiento de la batería

Para optimizar la vida útil de la batería, la afeitadora debe descargarse completamente, al menos una vez cada 6 meses (con un uso normal), y cargarse al máximo de su capacidad. No exponga la afeitadora a temperaturas superiores a 50 °C durante largos períodos de tiempo.

Información medioambiental

Esta afeitadora contiene baterías recargables de níquel-hidruro. Para preservar el medio ambiente, no tire este producto a la basura al final de su vida útil. Para reemplazarla puede acudir a un Centro de Asistencia Técnica Braun. Si prefiere sustituirla usted mismo, extraiga la batería como se indica en la página 46.

Sujeto a modificaciones sin previo aviso.

Este producto cumple con las normas de Compatibilidad Electro-magnética (CEM) establecidas por la Directiva Europea 89/336/EEC y las Regulaciones para Bajo Voltaje (73/23 EEC).



Vea las especificaciones eléctricas impresas en el cable especial de conexión.

Para preservar el medio ambiente, al final de la vida útil de su producto, deposítelo en los lugares destinado a ello de acuerdo con la legislación vigente.



Português

Os nossos produtos foram desenvolvidos para alcançar os mais altos standards de qualidade, funcionalidade e design. Esperamos que desfrute ao máximo da sua nova Máquina de Barbear Braun.

Aviso

A sua Máquina de Barbear vem provida com um transformador de baixa voltagem. Não substitua ou manipule qualquer peça da Máquina. Se o fizer poderá correr o risco de sofrer de um choque eléctrico.

Descrição

- 1 Tampa protectora
- 2 Rede de barbear
- 3 Bloco de lâminas
- 4 Aparador extensível
- 5 Luz indicadora de carregamento
- 6 Interruptor de funcionamento ligar/desligar
- 7 Cabo de conexão especial

Carregar a Máquina

A temperatura ideal para recarregar é de 15 °C a 35 °C.

- Utilizando o transformador de baixa voltagem, conecte a Máquina à corrente eléctrica com o interruptor de funcionamento em desligar.
- Quando carregar pela 1ª vez, deixe a Máquina carregar continuamente durante 4 horas. A luz indicadora (5) indica que a Máquina está a ser carregada. Quando a bateria se encontrar totalmente carregada, a Luz indicadora piscará constantemente. Então, informará que a bateria se encontra na sua capacidade máxima.
- Uma bateria com máxima capacidade oferece 30 minutos de barbeado sem estar ligada à corrente, dependendo do tamanho e crescimento da barba
- Assim que a Máquina fique completamente carregada, barbeie-se até ficar completamente descarregada. Depois carregue-a até à sua máxima capacidade. Os carregamentos consecuentes demorarão apenas 1 hora.
- A capacidade máxima da bateria só será antigida através de vários ciclos de carregamento/descarregamento.
- Se as baterias recarregáveis ficarem descarregadas, poderá barbear-se sem recarregar, apenas conectando a Máquina ao transformador de baixa voltagem e à corrente eléctrica.



Barbear-se

Retire a tampa protectora (1). Active o Interruptor de funcionamento (6). A rede flutuante automaticamente se ajusta aos contornos do rosto para um barbeado apurado e suave.

Para um pré barbear após alguns dias de não se ter barbeado, utilize o aparador extensível (4) para cortar os pêlos mais compridos. Para um barbear apurado e suave acabe de se barbear com a rede.

Aparar

Empurre o aparador extensível (a). O aparador permite-lhe aparar bigodes e patilhas. Inclusivé corta e apara extensas áreas de pêlos: ideal para fazer formas específicas nas patilhas, bigodes e barbas pequenas.

A utilização frequente do aparador extensível poderá reduzir a capacidade da bateria.

Conselhos práticos para um perfeito barbear

- Recomendamos que se barbeie antes do banho, uma vez que a pele tem tendência a ficar mais mole após o banho.
- Segure a Máquina a um ângulo (90°) contra a pele. Estique a pele e barbeie na direcção contrária ao do crescimento do pêlo.
- De modo a manter 100% de performance em cada barbeado, substitua a rede e o conjunto de lâminas a cada 18 meses.

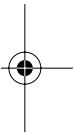

Limpeza



Este aparelho é lavável sob água corrente.

Aviso: Desconecte o aparelho da corrente antes de limpar.

Uma limpeza regular assegura uma máxima performance no barbear. Passando a cabeça da Máquina por baixo de água corrente após cada barbear é fácil e rápido para a manter limpa:

- Coloque a Máquina em funcionamento (sem cabo de conexão) e passe a cabeça da Máquina sob água quente corrente. Um sabonete natural poderá também ser utilizado desde que não contenha partículas e substâncias abrasivas. Retire toda a espuma e deixe a Máquina a funcionar por mais alguns segundos.
- De seguida desligue a Máquina e pressione os botões de libertação. Levante e retire a rede de barbear e o conjunto de lâminas. Depois deixe as peças da Máquina a secarem.

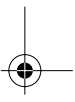
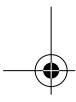



Como alternativa, poderá limpar a Máquina utilizando uma escova de limpeza que vem na embalagem (c).

- Desligue a Máquina off. Retire a rede de barbear.
- Utilizando a escova de limpeza, limpe o conjunto de lâminas e a área interior da cabeça da Máquina. Contudo, não deve limpar com a rede de barbear com a escova pois poderá danificá-la.

Manter a Máquina sempre em forma

A cada 4 semanas, limpe o conjunto de lâminas com agentes de limpeza Braun. Coloque uma gota de óleo para máquinas no aparador extensível e na rede de barbear (d).

Substituição de peças

De modo a manter 100% de performance em cada barbeado, substitua a rede e o conjunto de lâminas a cada 18 meses ou quando gastas. Substitua ambas as peças simultaneamente para um barbeado mais apurado e com menor irritação. (Rede de Barbear e Conjunto de Lâminas: série 1000)

Preservar as baterias

De modo a manter uma capacidade óptima das baterias recarregáveis, a Máquina tem que estar completamente descarregada (através de utilização normal) a cada 6 meses aproximadamente. Depois recarregue a Máquina até à sua capacidade máxima. Não exponha a Máquina a temperaturas superiores a 50°C durante largos períodos de tempo.

Informação ambiental

Este aparelho é fornecido com materiais recarregáveis níquel hidreto. De modo a proteger o ambiente, não coloque o aparelho juntamente com o lixo doméstico normal, no final da sua vida útil. Abrir a Máquina, conforme demonstrado na página 46, retire as baterias e entregue-as em qualquer Posto de Assistência Técnica ou em sites de coleção conforme regulamentações locais e nacionais.

Sujeito a alterações sem aviso prévio.

Este produto cumpre as normas de Compatibilidade Electro-magnética (CEM) estabelecidas pela Directiva Europeia 89/336/EEC e as Regulações para Baixa Voltagem (73/23 EEC).



Ver especificações eléctricas no impresso relativo ao cabo de conexão especial.

No final de vida útil do produto, por favor coloque-o no ponto de recolha apropriado.





Italiano

I nostri prodotti sono progettati per rispondere ai più elevati standard di qualità, funzionalità e design. Ci auguriamo che il suo nuovo rasoio Braun soddisfi pienamente le sue esigenze.

Avvertenza

Il rasoio è dotato di uno speciale cavo di ricarica con un adattatore a basso voltaggio integrato. Non cambiare o alterare nessuna delle sue parti per evitare il rischio di scosse elettriche.

Descrizione

- 1 Coprilamina
- 2 Lamina
- 3 Blocco coltelli
- 4 Tagliabasette
- 5 Spia di ricarica
- 6 Tasto acceso/spento
- 7 Cavo di ricarica



Come caricare il rasoio

La temperatura ottimale per la ricarica è compresa tra 15 °C e 35 °C.

- Utilizzando l'adattatore a basso voltaggio, collegare il rasoio (con il motore spento) alla corrente.
- Alla prima ricarica del rasoio, lasciarlo collegato continuamente alla presa di corrente per 4 ore. Non appena il rasoio comincia a ricaricarsi, si accenderà la spia (5). Quando le batterie del rasoio sono completamente cariche, la luce verde si illuminerà a intermittenza. Questo indica che la batteria viene mantenuta alla sua massima capacità.
- Una carica completa può fornire fino a 30 minuti di rasatura senza cavo, a seconda del grado di lunghezza della barba.
- Quando il rasoio è completamente carico, può essere utilizzato normalmente fin quando non è completamente scarico. Quindi, ricaricarlo nuovamente. Le ricariche successive dureranno circa 1 ora.
- La massima capacità delle batterie del rasoio viene raggiunta solo dopo diversi cicli di carica/scarica.
- Se le batterie sono scariche, è possibile radersi collegando direttamente il rasoio alla presa di corrente con l'adattatore a basso voltaggio.

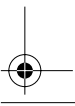
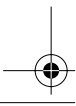
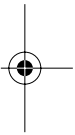

Rasatura

Togliere il coprilamina (1). Premere il tasto di accensione (6) e accendere il rasoio. La lamina oscillante si adatterà automaticamente ai profili del viso per una rasatura dolce e profonda.

Se si avesse una barba cresciuta da alcuni giorni, è opportuno prepararsi alla rasatura utilizzando il tagliasette (4) per accorciare i peli più lunghi. Completare quindi la rasatura normalmente con la lamina del rasoio.

Regolazione

Estrarre il tagliasette (a). Una volta attivato, esso consente la regolazione di basette, baffi, pizzis e barbe corte.

Un utilizzo frequente del tagliasette può ridurre la carica delle batterie.

Consigli per una rasatura perfetta

- E' consigliabile radersi prima di lavare il viso dal momento che la pelle risulta meno elastica dopo essere stata bagnata.
- Impugnare il rasoio mantenendo la giusta angolazione (90°) rispetto alla pelle. Tendere leggermente la pelle e radere in senso contrario alla direzione della crescita della barba.
- Per mantenere il 100% delle prestazioni del rasoio, sostituire la lamina e il blocco coltelli ogni 18 mesi, anche prima se risultano usurati.

Pulizia



Questo apparecchio può essere lavato sotto acqua corrente di rubinetto.

Attenzione: staccare l'apparecchio dal cordone di alimentazione prima di pulirlo con l'acqua.

Una pulizia regolare del rasoio assicura migliori prestazioni di rasatura. Risciacquare la testina del rasoio sotto l'acqua calda dopo ogni rasatura è un modo facile e veloce per mantenerla pulita:

- Accendere il rasoio (non collegato alla presa di corrente) e risciacquare la testina sotto l'acqua calda (b). Di tanto in tanto utilizzare sapone liquido naturale senza corpuscoli o sostanze abrasive. Sciacquare bene via la schiuma.
- Spegner il rasoio, rimuovere la lamina e il blocco coltelli e lasciarli ad asciugare.



In alternativa, è possibile pulire il rasoio utilizzando la spazzolina in dotazione (c):

- Spegnerne il rasoio, rimuovere la lamina e il blocco coltelli.
- Utilizzando la spazzolina, pulire il blocco coltelli e l'interno della testina. Non utilizzare la spazzolina per pulire la lamina dal momento che potrebbe danneggiarla.

Mantenere il rasoio in perfetta forma

Ogni 4 settimane, pulire il blocco coltelli con i prodotti per la pulizia Braun. Lubrificare blocco coltelli e tagliabasette con una goccia d'olio da macchina (d).

Sostituzione delle parti radenti

Per mantenere il 100% delle prestazioni del rasoio, sostituire la lamina e il blocco coltelli ogni 18 mesi, o anche prima se risultano usurati. Sostituire entrambe le parti allo stesso tempo per una rasatura più a fondo e con meno irritazioni. (Il codice identificativo della lamina e del blocco coltelli è: Serie 1000)

Mantenere le batterie ricaricabili in buono stato

Al fine di mantenere le batterie ricaricabili al massimo della loro capacità, il rasoio deve essere completamente scaricato (rasandosi) e ricaricato ogni 6 mesi circa. Non esporre il rasoio a temperature superiori a 50°C per lunghi periodi di tempo.

Tutela dell'ambiente

Questo apparecchio è dotato di batterie ricaricabili al nichel-idrato. Per tutelare l'ambiente, non gettare l'apparecchio tra i rifiuti domestici al termine del suo funzionamento ma portarlo presso il Centro di Assistenza autorizzato Braun a voi più vicino o presso i punti di raccolta specifici per questi rifiuti previsti dalla normativa vigente.

Salvo cambiamenti senza preavviso.

Questo prodotto è conforme alle normative EMC come stabilito dalla direttiva CEE 89/336 e alla Direttiva Bassa Tensione (CEE 73/23).



Specifiche elettriche: vedere indicazioni sullo speciale cavo di ricarica.

Onde tutelare l'ambiente, non buttate l'apparecchio tra i normali rifiuti al termine della sua vita utile, ma portatelo presso i punti di raccolta specifici per questi rifiuti previsti dalla normativa vigente.



Nederlands

Onze producten zijn ontworpen om aan de hoogste eisen van kwaliteit, functionaliteit en design te voldoen. Wij wensen u veel plezier met uw nieuwe Braun scheerapparaat.

Waarschuwing

Uw scheerapparaat is voorzien van een speciaal snoer met geïntegreerde zwakstroomadapter. Het uit elkaar halen of het vervangen van onderdelen van de adapter kan leiden tot een elektrische schok.

Omschrijving

- 1 Beschermkapje
- 2 Scheerblad
- 3 Messenblok
- 4 Tondeuse
- 5 Oplaadindicatie lampje
- 6 Aan/uit schakelaar
- 7 Snoer met zwakstroomadapter

Opladen

De beste omgevingstemperatuur tijdens het opladen van het scheerapparaat ligt tussen 15 °C en 35 °C.

- Sluit het scheerapparaat via de zwakstroomadapter aan op het lichtnet. Zorg ervoor dat het scheerapparaat uit staat.
- Wanneer u het scheerapparaat voor de eerste keer oplaadt, dient het apparaat tenminste 4 uur achter elkaar te worden opgeladen. Het oplaadindicatie lampje (5) geeft aan dat het scheerapparaat wordt opgeladen. Wanneer de oplaadbare accu volledig is opgeladen, zal het groene lampje eerst gaan knipperen en vervolgens doven. Dit geeft aan dat het scheerapparaat is opgeladen tot maximale capaciteit.
- Wanneer het scheerapparaat volledig is opgeladen, kunt u tot 30 minuten snoerloos scheren, afhankelijk van uw type baardgroei.
- Wanneer het apparaat volledig opgeladen is, kunt u deze ontladen door normaal gebruik. Volgende oplaadsessies zullen ongeveer 1 uur duren.
- De Maximale capaciteit van de accu zal pas worden bereikt na enkele oplaad/ontlaad sessies.
- Wanneer het scheerapparaat volledig ontladen is, kunt u zich scheren door het apparaat met het snoer met de zwakstroomadapter aan te sluiten op het lichtnet



Scheren

Verwijder het beschermkapje (1). Druk op de aan/uit schakelaar (6). Het zwevende scheerblad past zich automatisch aan aan uw huidoppervlak, voor een glad en comfortabel scheerresultaat.

Indien u zich een paar dagen niet heeft geschoren, kunt u met de tondeuse (4) de haartjes voor-scheren. Voor een glad en comfortabel scheerresultaat scheert u zich daarna met het scheerblad.

Tondeuse

Schuif de tondeuse omhoog (a). Hierdoor wordt het mogelijk om uw snor en bakkerbaarden nauwkeurig bij te werken. De tondeuse is geschikt voor het scheren van grotere gedeeltes: ideaal voor het in vorm scheren van bakkebaarden, snorren en korte baardjes.

Regelmatig gebruik van de tondeuse kan de capaciteit van de accu doen verminderen.

Tips voor een perfect scheerresultaat

- Wij raden u aan zich te scheren vóór het wassen van het gezicht, daar de huid na het wassen licht opgezwollen kan zijn
- Houdt het scheerapparaat altijd loodrecht (90°) op de huid. De huid licht spannen en tegen de richting van de baardgroei in scheren.
- Vervang het scheerblad en messenblok elke 1 1/2 jaar, of eerder wanneer de onderdelen zijn versleten, om een optimaal scheerresultaat te behouden.



Schoonmaken



Dit apparaat is geschikt om onder de kraan schoon te maken.

Waarschuwing: Verwijder het snoer uit het scheerapparaat alvorens het apparaat onder de kraan schoon te maken.

Regelmatig schoonmaken verbetert de prestaties van het scheerapparaat. Het scheerhoofd na iedere scheerbeurt afspoelen onder stromend water is een eenvoudige en snelle manier om uw scheerapparaat schoon te houden:

- Zet het scheerapparaat aan (snoerloos) en spoel het scheerhoofd schoon onder heet stromend water (b). U kunt tevens een natuurlijke zeep gebruiken, mits hier geen schurende deeltjes in zitten. Spoel het schuim goed af en laat het scheerapparaat gedurende een aantal seconden aan staan.
- Schakel het apparaat vervolgens uit en verwijder het scheerblad en messenblok. Laat deze onderdelen los van het scheerapparaat goed drogen.

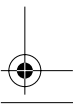
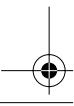



U kunt uw scheerapparaat tevens schoonmaken met het bijgeleverde borsteltje (c):

- Schakel het scheerapparaat uit. Verwijder het scheerblad.
- Gebruik het borsteltje om het messenblok en de binnenkant van het scheerhoofd schoon te maken. Gebruik het borsteltje nooit voor het scheerblad; dit kan het scheerblad beschadigen.

Uw scheerapparaat in topconditie houden

Reinig het messenblok elke 4 weken met Braun reinigingsmiddel. Smeer het scheerblad en de tondeuse met een druppel naaimachine olie (d).

Vervangen van onderdelen

Om de prestaties van uw scheerapparaat op 100% te houden, dient u uw scheerblad en messenblok om de 18 maanden te vervangen, of eerder wanneer deze versleten zijn. Vervang beide onderdelen tegelijkertijd voor een gladder scheeresultaat met minder huidirritatie. (Scheerblad en messenblok onderdeel nr. 1000)

De oplaadbare accu in goede staat houden

Om de maximale capaciteit en levensduur van de accu te behouden, dient het scheerapparaat (dmv. Scheren) ongeveer iedere 6 maanden te worden ontladen. Laadt vervolgens het scheerapparaat weer op tot volle capaciteit. Stel het scheerapparaat niet voor langere periodes bloot aan temperaturen boven 50 °C.

Milieu

Dit apparaat is voorzien van een nickel-hydride oplaadbare accu-unit. In het belang van het milieu raden wij u aan het apparaat aan het einde van zijn nuttige levensduur niet bij het gewone huisafval te deponeren. Lever het apparaat in bij de winkel waar u het apparaat heeft gekocht of bij een chemopunt. Indien u toch de accu unit zelf wilt verwijderen, verwijder deze dan als aangegeven op pagina 46.

Wijzigingen voorbehouden.

Dit produkt voldoet aan de EMC-voorschriften volgens de EEG richtlijn 89/336 en aan de EEG laagspannings richtlijn 73/23.



Voor elektrische specificaties: zie de speciale zwakstroomadapter.

Wij raden u aan het apparaat aan het einde van zijn nuttige levensduur, niet bij het gewone huisafval te deponeren, maar op de daarvoor bestemde adressen.





Dansk

Vores produkter er skabt til at opfylde de højeste krav, hvad angår kvalitet, funktionalitet og design. Vi håber, du vil få stor glæde af din nye barbermaskine fra Braun.

Advarsel

Barbermaskinen er forsynet med et specialkabel med integreret strømfor-
syning med ekstra lav spænding for større sikkerhed. Ingen af delene
må udskiftes eller manipuleres med, da man ellers risikerer at få elektrisk
stød.

Beskrivelse

- 1 Beskyttelseshætte til skæreblad
- 2 Skæreblad
- 3 Lamelkniv
- 4 Trimmer til langt hår
- 5 Opladningslys
- 6 Tænd/sluk-knap
- 7 Specialkabel



Opladning

Opladning foregår bedst ved en temperatur mellem 15 °C og 35 °C.

- Barbermaskinen tilsluttes en stikkontakt via specialledningen. Barbermaskinen skal være slukket.
- Når barbermaskinen oplades første gang, skal den oplade konstant i fire timer. Det lys (5) viser, at barbermaskinen er under opladning. Når batteriet er fuldt opladet, blinker opladningslyset. Det viser, at batteriet er fuldt opladet.
- En fuld opladning giver op til 30 minutters trådløs barberingstid afhængig af skægvækst.
- Når barbermaskinen er fuldt opladet, aflades den ved normal brug. Derefter genoplades den til fuld kapacitet. Senere opladninger tager ca. en time.
- Den maksimale batterikapacitet nås først efter flere cyklusser med ladning og afladning.
- Hvis de genopladelige batterier aflades, kan du også barbære dig ved at sætte barbermaskinen til en stikkontakt via specialkablet.

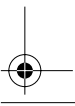
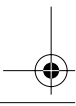



Barbering

Fjern beskyttelsehætten til skærebladet (1). Tryk på tænd/sluk-knappen (6). Den svævende skærebladsramme tilpasser sig automatisk din hudskonturer og giver en tæt og glat barbering.

Til forbarbering efter nogle dage, hvor du ikke har barberet dig, skal du bruge trimmeren til langt hår (4) for at forbarbere lange skægghår. Afslut med skærebladet for at få en tæt, glat barbering.

Trimning

Skub trimmeren til langt hår (a) ud. Den giver en præcis trimning af overskæg og bakkenbarter og klipper og trimmer større områder jævnt. Ideel til at give facon til bakkenbarter, overskæg og kort skæg.

Hyppig brug af trimmeren til langt hår kan nedsætte batteriets kapacitet.

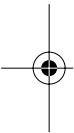

Tips til den perfekte barbering

- Vi anbefaler, at du barberer dig, før du vasker dig, fordi huden svulmer en smule op efter vask.
- Hold barbermaskinen i en ret vinkel (90°) mod huden. Stræk huden og barber mod skæggets vokseretning.
- For at opretholde en optimal barbering skal skæreblad og lamelkniv udskiftes mindst efter 1 1/2 års brug, eller når de er slidte.

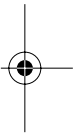

Rengøring



Apparatet kan vaskes under rindende vand.

Advarsel: Adskil den håndholdte del fra strømforsyningen, før den rengøres i vand.

Regelmæssig rengøring sikrer en bedre barbering. En let og hurtig måde at holde barberhovedet rent på er at skylle det under rindende vand:

- Tænd for barbermaskinen (trådløs), og skyl barberhovedet under varmt, rindende vand (b). En natursæbe kan også anvendes, forudsat at den ikke indeholder små partikler eller slibemidler. Skyl al skummet væk, og lad barbermaskinen køre i et par sekunder mere.
- Sluk derefter for barbermaskinen, og fjern skæreblad og lamelkniv. Lad derefter de adskilte dele tørre.

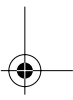
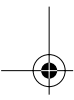



Alternativt kan barbermaskinen renses med den medfølgende børste (c):

- Sluk for barbermaskinen. Fjern skærebladet.
- Ved hjælp af børsten renses lamelkniven og indersiden af barberhovedet. Skærebladet må imidlertid ikke renses med børsten, da det kan ødelægge bladet.

Hold din barbermaskine i topform

Ca. hver fjerde uge renses lamelkniven med Brauns rensmiddel. Dryp en dråbe let maskinolie på trimmeren til langt hår og barbermaskinens skæreblad (d).

Udskiftning af barbermaskinens dele

For at opretholde en optimal barbering skal skæreblad og lamelkniv udskiftes mindst efter 1 1/2 års brug, eller når de er slidte. Udskift begge dele på samme tid for at få en tættere barbering med mindre hudirritation. (Skæreblad og lamelkniv: 1000-serien)

Sådan bevares batterierne

For at bevare optimal kapacitet på de genopladelige batterier skal barbermaskinen aflades fuldstændigt (ved barbering) ca. hver 6. måned. Derefter genoplades barbermaskinen til fuld kapacitet. Barbermaskinen må ikke udsættes for temperaturer over 50 °C i længere perioder.

Miljømæssige oplysninger

Dette apparat er forsynet med genopladelige batterier indeholdende nikkelhydrid. For at beskytte miljøet bør apparatet efter endt levetid ikke kasseres sammen med husholdningsaffaldet. Åbn kabinettet som vist på side 47, tag batterierne ud og aflever dem i butikken, hvor du har købt maskinen, eller ved opsamlingssteder ifølge nationale eller lokale regler.

Kan ændres uden varsel.

Dette produkt opfylder EMC-bestemmelserne i EU-direktiv 89/336/EEC og Lavspændingsregulativet (73/23 EEC).



Elektriske specifikationer findes på specialkablet.

Når produktet er udtjent, bør det bortskaffes via de særlige indsamlingssteder i landet.





Norsk

Våre produkter er utviklet etter de høyeste standarder for kvalitet, funksjon og design. Vi håper at du vil få stor glede av din nye Braun barbermaskin.

Advarsel

Barbermaskinen har en spesialledning med integrert lavspenningsadapter. Ikke bytt den ut eller foreta endringer på den. Gjør du det, kan det medføre fare for elektrisk støt.

Beskrivelse

- 1 Beskyttelseskappe for skjæreblad
- 2 Skjæreblad
- 3 Lamellkniv
- 4 Langhårtrimmer
- 5 Ladelys
- 6 På/av-bryter
- 7 Spesialledning

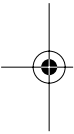

Lading

Beste temperatur for lading er mellom 15 °C og 35 °C.

- Koble barbermaskinen til et strømuttak ved hjelp av spesialledningen. La den være avslått.
- Ved første lading skal barbermaskinen lades uavbrutt i 4 timer. Det ladelyset viser at barbermaskinen lades. Ladelyset blinker når batteriet er helt oppladet. Dette viser at batteriet har full kapasitet.
- En full oppladning gir opptil 30 minutter med ledningsfri barbering, avhengig av skjeggveksten.
- Når barbermaskinen er helt oppladet, bør den lades ut ved normal bruk. Deretter skal den lades helt opp på nytt. Etterfølgende ladinger vil ta omtrent 1 time.
- Full batterikapasitet oppnås først etter flere ladinger og utladinger.
- Hvis de oppladbare batteriene er utladet, kan du allikevel barbere deg ved å koble barbermaskinen til en stikkontakt, med spesialledningen.

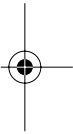

Barbering

Ta av beskyttelseskappen (1). Trykk på på/av-bryteren (6). Skjærebladrammen tilpasser seg automatisk til huden og gir en tett og myk barbering.

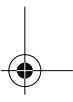
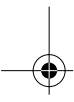



Til forbarbering, etter noen dager uten barbering, tar du lange hår med langhårtrimmeren (4). Bruk så skjærebladet til en tett og glatt avsluttende barbering.

Trimming

Skv ut langhårtrimmeren (a). Den brukes til kontrollert trimming av barter og kinnskjegg. Den kutter og trimmer jevnt på større områder; ideell til forming av kinnskjegg, barter og mindre områder med kort skjegg.

Jevnlig bruk av langhårtrimmeren reduserer batterikapasiteten.

Tips for perfekt barbering

- Vi anbefaler at du barberer deg før du vasker deg, fordi huden har en tendens til å bli lett hoven etter vask.
- Hold barbermaskinen vinkelrett (90°) mot huden. Strekk huden og barber mot skjeggets vekstretning.
- For å beholde 100 % barberingsytelse må du skifte ut skjærebladet og lamellkniven minst hver 18. måned eller når de er slitt.

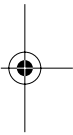
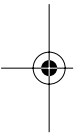

Rengjøring



Dette apparatet kan rengjøres under rennende vann.

Advarsel: Fjern nettledningen før maskinen rengjøres i vann.

Jevnlig rengjøring sikrer bedre barbering. Skjærehodet kan enkelt og raskt rengjøres under rennende vann etter bruk:

- Slå på barbermaskinen (ledning frakoblet) og rengjør skjærehodet under varmt rennende vann (b). Naturbasert såpe kan også brukes hvis den ikke inneholder slipemidler. Skyll bort alt skum, og la barbermaskinen gå i noen sekunder.
- Deretter slår du av barbermaskinen, og tar av skjærebladet og lamellkniven. La delene tørke.

Du kan også rengjøre barbermaskinen med børsten som følger med (c):

- Slå av barbermaskinen. Ta av skjærebladet.
- Bruk børsten til å rengjøre lamellkniven og indre del av skjærehodet. Ikke rengjør skjærebladet med børsten fordi dette kan skade bladet.

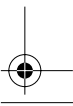
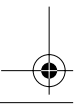

Vedlikeholde barbermaskinen

Rengjør skjærehodet omtrent hver fjerde uke, med Braun rensemiddel. Drypp en dråpe symaskinolje på langhårtrimmeren og skjærebladet (d).

Skifte skjæredeler

For å opprettholde 100 % barberingsytelse må du skifte ut skjærebladet og lamellkniven minst hver 18. måned eller når de er slitt. Hvis du skifter begge deler samtidig, får du en tettere barbering med mindre hudirritasjon. (Skjæreblad og lamellkniv: 1000-serien)

Vedlikeholde batteriene

For å opprettholde full batterikapasitet må barbermaskinen lades ut (ved barbering) omtrent hver 6. måned. Lad den deretter opp til full kapasitet. Ikke utsett barbermaskinen for temperaturer over 50 °C i lengre tid.

Miljømessige hensyn

Dette apparatet har oppladbare nikkelforhydrid-batterier. Av miljøhensyn bør ikke dette produktet kastes sammen med husholdningsavfall etter endt levetid. Åpne dekslet slik det er vist på side 47. Ta ut batteriene og lever dem til forhandleren eller en miljøstasjon. Følg nasjonale og lokale regler.

Med forbehold om endringer.

Dette produktet oppfyller kravene i EU-direktivene EMC 89/336/EEC og Low Voltage 73/23/EEC.



Elektriske spesifikasjoner er angitt på spesial ledningssettet.

Ved slutten av produktets levetid bør det avhendes på en kommunal miljøstasjon eller leveres til en elektroforhandler.





Svenska

Våra produkter är utformade för att uppfylla högsta krav vad gäller kvalitet, funktionalitet och design. Vi hoppas att du kommer att ha mycket nytta av din nya rakapparat från Braun.

Varning

Rakapparaten har en specialsladd med inbyggd, säker elförsörjning med extra låg spänning. Du ska därför inte byta ut eller ändra någon del av den. Det finns då risk för att du utsätts för elektriska stötar.

Beskrivning

- 1 Skyddskåpa för skärblad
- 2 Skärblad
- 3 Saxhuvud
- 4 Långhårstrimmer
- 5 Laddningslampan
- 6 På/Av-knapp
- 7 Specialsladd



Laddning

Bästa omgivningstemperatur vid laddning är 15–35°C.

- Anslut rakapparaten till ett vägguttag med hjälp av specialsladden med motorn avstängd.
- När du laddar rakapparaten för första gången ska den laddas oavbrutet i fyra timmar. Den laddningslampan (5) visar att rakapparaten laddas. När batteriet är färdigladdat blinkar laddningslampan. Detta indikerar att batteriet har full kapacitet.
- När apparaten är fulladdad ger den upp till 30 minuters sladdlös rakning beroende på din skäggväxt.
- När rakapparaten är fulladdad ska den användas tills den är helt urladdad. Ladda sedan till full kapacitet igen. Därefter tar en uppladdning ca 1 timme.
- Maximal batterikapacitet uppnås dock först efter flera upp- och urladdningscykler.
- Om det laddningsbara batteriet är urladdat kan du också använda rakapparaten ansluten till eluttaget via specialsladden.

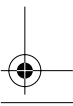
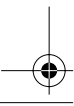
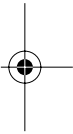



Rakning

Ta bort skärbladets skyddskåpa (1). Tryck på På/Av-knappen (6). Den rörliga skärbladsramen anpassas automatiskt till hudens form för en nära och mjuk rakning.

Om du vill trimma skäggväxten när du inte rakat dig på några dagar använder du långhårstrimmern (4) för att trimma längre skäggrån. Avsluta sedan med skärbladet för en riktig slätrakning.

Trimning

Skjut ut långhårstrimmern (a). Med denna kan du trimma mustasch och polisonger. Den trimmar stora områden jämnt: idealiskt för att forma polisonger, mustascher och haxskägg.

Om du använder trimmern för långt skägg ofta kan batteriets kapacitet försämras.

Tips för den perfekta rakningen

- Vi rekommenderar att du rakar dig innan du tvättar dig eftersom huden tenderar att bli något svullen när man har tvättat sig.
- Håll rakapparaten i en rätt vinkel (90°) mot huden. Sträck ut huden och raka mot skäggets växtriktning.
- För att rakapparaten ska behålla sin prestanda till 100 % ska du byta ut bladet och saxhuvudet minst var 18:e månad, eller när de är slitna.

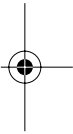
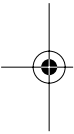

Rengöring



Den här rakapparaten går att rengöra under rinnande vatten.
Varning: Koppla loss nätsladden från rakapparaten innan den rengörs med vatten.

Regelbunden rengöring ger bättre rakning. Skölj rakhuvudet under rinnande vatten efter varje rakning. Det är ett enkelt och snabbt sätt att hålla apparaten ren:

- Sätt på rakapparaten (utan sladd) och rengör rakhuvudet under varmt, rinnande vatten (b). Naturbaserad tvål kan också användas såvida den inte innehåller några partiklar eller slipmedel. Skölj av allt lödder och låt rakapparaten vara igång i ytterligare några sekunder.
- Stäng sedan av rakapparaten, ta loss skärbladet och saxhuvudet. Låt de isärtagna delarna torka.

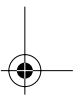
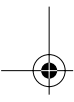



Du kan också rengöra rakapparaten med den bifogade borsten (c):

- Stäng av rakapparaten. Ta bort skärbladet.
- Använd borsten för att rengöra saxhuvudet och rakhuvudets inre delar. Du ska dock inte rengöra skärbladet med borsten eftersom detta kan skada bladet.

Håll rakapparaten i topptrim

Rengör saxhuvudet med Brauns rengöringsmedel ungefär var fjärde vecka. Smörj trimmern för långt skägg och skärbladet (d) med en droppe symaskinsolja.

Byt ut rakapparatsens delar

För att rakapparaten ska behålla sin prestanda till 100 % ska du byta ut bladet och saxhuvudet minst var 18:e månad, eller när de är slitna. Byt båda delarna samtidigt för en närmare rakning med mindre hudirritation. (Skärblad och saxhuvud: 1000-serien.)

Vårda batterierna

För att de laddningsbara batterierna ska behålla maximal kapacitet måste rakapparaten laddas ur helt (genom rakning) ungefär var sjätte månad. Ladda sedan rakapparaten till full kapacitet. Exponera inte rakapparaten för temperaturer högre än 50°C under längre tidsperioder.

Skydda miljön

Denna apparat innehåller laddningsbara nickelhydridbatterier. Av miljö-hänsyn ska apparaten inte slängas bland det vanliga hushållsavfallet när den är uttjänt. Öppna höljet enligt instruktionerna på sidan 47, ta bort och lämna batterierna hos din återförsäljare eller vid en återvinningsstation enligt nationella eller lokala bestämmelser.

Med förbehåll för ändringar.

Denna produkt är anpassad till EMC-föreskrifterna 89/336/EEC och till lågspänningsdirektivet (73/23 EEC).



För elektriska specifikationer, se texten på specialsaddan.

Lämna vänligen in produkten på lämplig återvinningsstation när den är förbrukad.





Suomi

Tuotteemme on suunniteltu täyttämään korkeimmat laatu-, toimivuus- ja muotoiluvaatimukset. Toivottavasti saat paljon iloa ja hyötyä uudesta Braun-parranajokoneestasi.

Varoitus

Parranajokoneen verkkojohto on varustettu matalajännitesovittimella. Sähköiskun vaaran välttämiseksi älä vaihda siihen mitään osia tai tee mitään muutoksia.

Kuvaus

- 1 Teräverkon suojus
- 2 Teräverkko
- 3 Leikkuri
- 4 Pitkien partakarvojen viimeistelijä
- 5 Latauksen merkkivalo
- 6 Virtakytkin
- 7 Verkkojohto



Lataaminen

Lataamisen kannalta ympäristön paras lämpötila on 15–35 °C.

- Kytke parranajokone verkkojohdolla verkkovirtaan moottori sammutettuna.
- Lataa parranajokonetta ensimmäisellä latauskerralla yhtäjaksoisesti 4 tuntia. Vihreä latausmerkkivalo (5), että parranajokonetta ladataan. Kun akku on täysin latautunut, latauksen merkkivalo vilkkuu jaksottaisesti. Tämä on merkki siitä, että akku on saavuttanut täyden kapasiteettinsa.
- Kun parranajokone on ladattu täyteen, akussa riittää virtaa jopa 30 minuutin parranajoon parrankasvusta riippuen.
- Kun parranajokone on täysin latautunut, anna akun tyhjentyä kokonaan normaalissa käytössä. Lataa tämän jälkeen akku täyteen. Seuraavat lataukset kestävät noin 1 tunnin.
- Täysi akkukapasiteetti saavutetaan kuitenkin vasta useiden latausten ja purkausten jälkeen.
- Jos akut ovat tyhjentyneet, voit käyttää parranajokonetta kytkemällä verkkojohton verkkovirtaan.

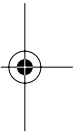

Ajaminen

Poista teräverkon suojus (1). Käynnistä laite virtakytkimestä (6). Kääntyvä ajopää mukautuu automaattisesti ihollesi tehden parranajosta tasaisen.

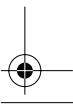
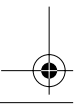



Kun ajat ensimmäistä kertaa muutamaan päivään, käytä pitkien partakarvojen leikkuria (4) pitkien partakarvojen poistamiseen. Tarkan ja tasaisen lopputuloksen saat viimeistelemällä ajon teräverkolla.

Trimmaus

Ota pitkien partakarvojen leikkuri (a) esille. Sen avulla viikset ja pulisongit voidaan trimmata hallitusti. Se leikkaa ja trimmaa laajoja alueita tasaisesti: ihanteellinen pulisongien, viiksien ja osittain lyhyen parran muotoiluun.

Jos pitkien partakarvojen leikkuria käytetään usein, akkukapasiteetti voi pienentyä.

Vihjeitä täydelliseen parranajoon

- On suositeltavaa ajaa parta ennen kasvojen pesua, sillä kasvojen peseminen turvottaa ihoa hieman.
- Pidä parranajokonetta suorassa kulmassa (noin 90°) ihoon nähden. Venytä ihoa ja aja parta karvojen kasvusuuntaa vasten.
- Parhaan mahdollisen ajotuloksen saavuttamiseksi teräverkko ja leikkuri kannattaa vaihtaa vähintään 18 kuukauden välein tai kun ne ovat kuluneet.

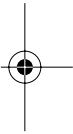
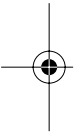

Puhdistaminen



Tämä laite voidaan puhdistaa juoksevan veden alla.

Varoitus: Irrota parranajokone virtalähteestä ennen laitteen puhdistamista vedellä.

Säännöllinen puhdistaminen varmistaa paremman ajotuloksen. Ajopään huuhteleva jokainen ajokerran jälkeen juoksevilla vedellä on helppo ja nopea tapa pitää se puhtaana.

- Irrota parranajokoneesta virtajohto ja kytke siihen virta. Huuhteleva ajopää kuumalla juoksevilla vedellä (b). Myös luonnonaineista valmistettua saippuaa voi käyttää, kunhan se ei sisällä hiukkasia eikä hankaavia aineosia. Huuhteleva kaikki vaahto pois ja anna parranajokoneen olla käynnissä muutaman sekunnin ajan.
- Kytke seuraavaksi parranajokoneesta virta pois, irrota teräverkko ja leikkuri. Jätä irrotetut osat kuivumaan.

Laitteen voi puhdistaa myös käyttämällä sen mukana toimitettua harjaa (c):

- Sammuta parranajokoneesta virta. Irrota teräverkko.

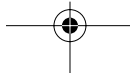
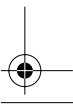
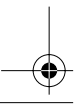



- Puhdista leikkuri ja ajopään sisäosat harjalla. Älä kuitenkaan puhdista harjalla teräverkkoa, sillä teräverkko voi vahingoittua.



Parranajokon een pitäminen huippukunnossa

Puhdista leikkuuterä Braunin puhdistusaineella noin neljän viikon välein. Voitele pitkien partakarvojen leikkuri ja teräverkko pisaralla ohutta koneöljyä (d).

Parranajo-osien vaihtaminen

Parhaan mahdollisen ajotuloksen saavuttamiseksi teräverkko ja leikkuri kannattaa vaihtaa vähintään 18 kuukauden välein tai kun ne ovat kuluneet. Kun vaihdat molemmat osat samanaikaisesti, lopputuloksena on tarkempi parranajo ja vähemmän ihoärsytystä. (Teräverkko ja leikkuri: 1000-sarja)

Akkujen tehokkuuden säilyttäminen

Jotta akkujen varauskyky pysyisi mahdollisimman hyvänä, niiden varaus täytyy tyhjentää kokonaan normaalissa käytössä noin 6 kuukauden välein. Lataa tämän jälkeen laitteen akut täyteen. Älä säilytä laitetta pitkään yli 50 °C:een lämpötilassa.

Ympäristöseikkoihin liittyviä tietoja

Tässä laitteessa on ladattavat nikkelihydridiakut. Kun laite on tullut elinkaarensa päähän, säästä ympäristöä äläkä hävitä sitä kotitalousjätteiden mukana. Avaa kotelo sivulla 47 kuvatulla tavalla, poista ja hävitä akut viemällä ne myymälään tai kansallisten tai paikallisten säädösten mukaisiin keräyspisteisiin.

Oikeudet muutoksiin pidätetään.

Tämä tuote täyttää EU-direktiivin 89/336/EEC mukaiset EMC-vaatimukset sekä matalajännitettä koskevat säännökset (73/23 EEC).



Katso sähkömääräyksiä koskevat tiedot matalajännitesovittimesta.

Hävitä tuote käyttöiän päättyessä viemällä se asianmukaiseen keräyspisteeseen.





Türkçe

Ürünlerimiz yüksek kalite, fonksiyonellik ve şık dizayn ilkelerine bağlı kalınarak tasarlanmıştır. Yeni Braun tıraş makinenzden memnun kalacağınızı umarız.

Uyarı

Tıraş makinenzin ekstra düşük voltaj için güvenlik sağlayan adaptör içeren özel kablo seti vardır. Bu setin hiçbir parçasını değiştirmeyin veya başka amaçlar için kullanmayın aksi takdirde elektrik şoku meydana gelebilir.

Tanım

- 1 Elek koruma kapağı
- 2 Tıraş makinesi eleği
- 3 Sakal kesici
- 4 Uzun tüy düzeltici
- 5 Şarj ışığı
- 6 Açma/Kapama düğmesi
- 7 Özel kablo seti



Şarj etmek

Şarj etmek için en ideal sıcaklık 15°C ve 35°C arasındır.

- Tıraş makinenz kapalıyken özel kablo setini kullanarak makinenzizi prize takın.
- Makinenizi ilk defa şarj ederken 4 saat boyunca şarj edin. Şarj ışığı (5) makinenzin şarj olmakta olduğunu gösterir. Makine tamamen şarj olduğunda şarj ışığı yanıp söner. Bu, pilin tam kapasiteye ulaştığını gösterir.
- Tam şarj olmuş bir makine sakal uzunluğunuza göre ortalama 30 dakikalık kablosuz kullanım sağlar.
- Tıraş makinesi şarj olduktan sonra, şarjı bitene dek kullanın. Daha sonra, tam dolana kadar yine şarj edin. Şarj olması yaklaşık 1 saat sürecektir.
- Birkaç şarj döngüsünden sonra pil maksimum performansına ulaşacaktır.
- Şarj edilebilir piller boşsa, tıraş makinenzizi elektrikli olarak da (özel kablo setini prize takarak) kullanabilirsiniz.



Tıraş Olmak

Elek koruyucu kapağı çıkartın (1). Açma/Kapama düğmesine basarak çalıştırın. Oynar başlıklı elek çerçevesi otomatik olarak yüzünüzdeki kıvrımlara uyum sağlayarak yakın ve pürüzsüz bir tıraş sağlar.





Birkaç gün tıraş olmamışsanız tıraş öncesinde uzun sakalları kesmek için uzun tüy düzelticisini kullanın (4). Yakın ve pürüzsüz tıraş için tıraşınızı elek başlığı ile bitirin.

Düzeltilme

Uzun tüy düzelticisini basarak açın.

Uzun tüy düzelticisinin çok sık kullanımı pilin şarj kapasitesini azaltabilir.

Mükemmel tıraş için ipuçları

- Yüzünüzü yıkamadan önce tıraş olmanızı tavsiye ederiz çünkü yüz yıkadıktan sonra cilt ve sakalınız şişebilir.
- Tıraş makinenizi yüzünüze 90°lik açı ile tutun. Cildinizi gerin ve tıraş makinenizi sakal uzama yönünün aksine doğru hareket ettirin.
- %100 tıraş performansı için elek ve kesicinizi en az her 18 ayda bir değiştirin.

Temizleme



Bu cihaz musluk suyu altında temizlenmeye uygundur.

Uyarı: Musluk altında temizlemeden önce cihazın şebeke ceryanı ile bağlantısını kesiniz.

Düzenli temizleme daha iyi performans sağlar. Makinenizi temiz tutmanın en kolay yolu her kullanımdan sonra sudan geçirerek durulamaktır.

- Kablosuzken tıraş makinesini çalıştırın ve tıraş başlığını sıcak suyun altına tutun (b). Partiküller ve aşındırıcı maddeler bulundurmaman bir sabun da kullanılabilir. Köpük temizlendikten sonra birkaç saniye daha suyun altında tutun.
- Sonra, makineyi kapatın, tıraş makinesi eleğini ve kesici bölümü çıkarın. Sonra bu parçaları kurumaya bırakın.

Alternatif olarak, tıraş makinenizi verilen fırça ile de temizleyebilirsiniz (c):

- Tıraş makinenizi kapatın. Tıraş makinesi eleğini çıkarın.
- Fırçayı kullanarak kesiciyi ve iç tarafını temizleyin. Fakat, eleği fırça ile temizlemeyin, eleğe zarar verebilir.

Tıraş makinenizi en iyi durumda tutmak için

Yaklaşık 4 haftada bir kesiciyi Braun temizleyicileriyle temizleyin. Uzun tüy düzelticisine ve tıraş başlığı eleğinin üstüne (d) bir damla hafif makine yağı damlatın.





Tıraş makinesi parçalarını yenilemek

%100 tıraş performansı sağlamak için tıraş makinesi eleğini ve kesiciyi her 18 ayda bir ya da eskidiğinde yenileyin. Daha az cilt tahrişi ve yakın tıraş için iki parçayı aynı anda değiştirin. (Tıraş makinesi eleği ve kesici: 1000 serisi)

Pillerin saklanması

Şarj edilebilir pillerin maksimum kapasitede çalışabilmesi için, tıraş makinenizin şarjının yaklaşık her 6 ayda bir tamamen boşalması gerekir (tıraş olarak). Sonra tıraş makinenizi tam dolana kadar şarj edin. Tıraş makinenizi uzun süreli olarak 50°C nin üzerindeki ortamlarda bırakmayın.

Çevre ile ilgili hususlar

Bu araç nikel-hidrid şarj edilebilir pillerle çalışır. Çevreyi korumak için aracın kullanım süresi bittiğinde lütfen çöplüğe atmayınız. Sayfada gösterildiği gibi makineyi açın 47, yerel veya nasyonel kanunların gösterdiği yerlere pilleri atın ya da parekendecinizde pilleri yok edin.



Bildirim yapılmadan değiştirilebilir.

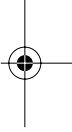

Elektrikle ilgili direktifler özel kordon setinin üzerinde yazmaktadır.

Üretici firma ve CE işareti uygunluk değerlendirme kuruluşu:

Braun GmbH
Frankfurter Straße 145
61476 Kronberg / Germany
☎ (49) 6173 30 0
Fax (49) 6173 30 28 75
Braun_infoline@Gillette.com

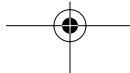
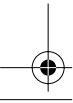



Ελληνικά

Τα προϊόντα μας κατασκευάζονται έτσι ώστε να πληρούν τα υψηλότερα πρότυπα ποιότητας, λειτουργικότητας και σχεδιασμού. Ελπίζουμε ότι θα ικανοποιηθείτε απόλυτα από τη νέα σας ξυριστική μηχανή Braun.

Προσοχή

Η συσκευή διατίθεται με μετασχηματιστή χαμηλής τάσης για ασφάλεια. Δεν πρέπει να αντικαταστήσετε ή να τροποποιήσετε οποιοδήποτε μέρος του. Σε αντίθετη περίπτωση υπάρχει κίνδυνος ηλεκτροπληξίας.

Περιγραφή

- 1 Προστατευτικό κάλυμμα πλέγματος
- 2 Πλέγμα ξυρίσματος
- 3 Κοπτικό σύστημα
- 4 Κόπτης μακρών τριχών
- 5 Ένδειξη φόρτισης
- 6 Διακόπτης λειτουργίας (ανοίγμ./κλεισίμ.)
- 7 Ειδικό σετ καλωδίου



Φόρτιση

Η καλύτερη θερμοκρασία περιβάλλοντος για τη φόρτιση είναι από 15 °C – 35 °C.

- Χρησιμοποιώντας το ειδικό σετ καλωδίου, συνδέστε τη ξυριστική μηχανή με την κεντρική παροχή ρεύματος, με το διακόπτη λειτουργίας στη θέση κλεισίμ.
- Όταν φορτίζετε τη ξυριστική μηχανή για πρώτη φορά, αφήστε τη να φορτίζει συνεχόμενα για 4 ώρες. Η πράσινη ένδειξη (5) σημαίνει ότι η μηχανή φορτίζει. Όταν η μπαταρία φορτιστεί πλήρως, η πράσινη λυχνία αναβοσβήνει.
- Μια πλήρης φόρτιση επαρκεί για 30 λεπτά λειτουργίας χωρίς καλώδιο, ανάλογα με το μέγεθος της τρίχας.
- Από τη στιγμή που η μηχανή έχει φορτιστεί πλήρως, χρησιμοποιείστε τη μέχρι να αποφορτιστεί. Στη συνέχεια επαναφορτίστε τη πλήρως. Οι επόμενες φορτίσεις θα διαρκούν περίπου 1 ώρα.
- Η μέγιστη απόδοση μπαταρίας θα είναι εφικτή μετά από μερικούς κύκλους φόρτισης/αποφόρτισης.
- Αν οι μπαταρίες είναι πλήρως αποφορτισμένες, τότε μπορείτε να ξυριστείτε έχοντας τη μηχανή στη πρίζα διαμέσου του μετασχηματιστή.

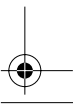
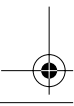



Ξύρισμα

Αφαιρέστε το προστατευτικό κάλυμμα του πλέγματος (1). Ενεργοποιήστε το διακόπτη ανοίγμ./κλεισίμ. (6). Το πλαίσιο του πλέγματος προσαρμόζεται αυτόματα στην επιφάνεια του προσώπου για πιο βαθύ ξύρισμα.

Σε περίπτωση που έχετε να ξυριστείτε αρκετές ημέρες, τότε αρχικά θα πρέπει να χρησιμοποιήσετε το κόπτη μακρών τριχών (4). Για πιο βαθύ και πιο λείο αποτέλεσμα χρησιμοποιήστε στη συνέχεια το πλέγμα.

Περιποίηση

Ωθείστε προς τα επάνω τον κόπτη μακρών τριχών (α). Ο κόπτης επιτρέπει ελεγχόμενο σχεδιασμό μουστακιού και φαβορίτων. Κόβει και περιποιείται ομοίμορφα μεγαλύτερες περιοχές: είναι ιδανικός για το σχεδιασμό φαβορίτων, μουστακιού και κοντής γενειάδας.

Συχνή χρήση του κόπτη μακρών τριχών ίσως να μειώσει την απόδοση της μπαταρίας.

Χρήσιμες συμβουλές για τέλειο ξύρισμα

- Συνιστούμε να ξυρίζετε πριν το πλύσιμο, καθώς το δέρμα τείνει να πρήζεται ελαφρά μετά το πλύσιμο.
- Θα πρέπει να κρατάτε την ξυριστική μηχανή κάθετα στο δέρμα, σε ορθή γωνία (90°). Τεντώνετε το δέρμα και ξυρίζετε αντίθετα στη κατεύθυνση της ανάπτυξης της γενειάδας.
- Για να έχετε 100% τέλειο αποτέλεσμα, το πλέγμα ξυρίσματος και το κοπτικό σύστημα θα πρέπει να αντικαθίστανται τουλάχιστον κάθε 18 μήνες, ή όταν τα εξαρτήματα έχουν φθαρεί.

Καθαρισμός



Αυτή η συσκευή είναι κατάλληλη για πλύσιμο κάτω από τρεχούμενο νερό.

Προσοχή: Βγάλτε τη συσκευή από τη πρίζα πριν τη πλύνετε.

Το τακτικό καθαρίσμα εγγυάται καλύτερη απόδοση ξυρίσματος. Ξεπλένοντας την ξυριστική κεφαλή μετά από κάθε ξύρισμα κάτω από τρεχούμενο νερό είναι ένας εύκολος και γρήγορος τρόπος για να τη διατηρήσετε καθαρή:

- Τοποθετήστε το διακόπτη στη θέση on (χωρίς το καλώδιο) και καθαρίστε τη κεφαλή κάτω από ζεστό νερό βρύσης (b). Μπορείτε να

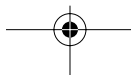



χρησιμοποιήστε φυσικό σαπούνι χωρίς προσθήκη χημικών και μαλακτικών στοιχείων. Στη συνέχεια ξεπλένετε τη κεφαλή πολύ καλά και αφήστε τη μηχανή σε λειτουργία για μερικά ακόμη δευτερόλεπτα.

- Έπειτα, θέστε τη συσκευή εκτός λειτουργίας και αφαιρέστε το πλέγμα ξυρίσματος και το κοπτικό σύστημα. Αφήστε τα αποσυναρμολογημένα μέρη να στεγνώσουν.

Εναλλακτικά, μπορείτε να καθαρίσετε τη ξυριστική μηχανή χρησιμοποιώντας το ειδικό βουρτσάκι που παρέχεται (c).

- Θέστε τη συσκευή εκτός λειτουργίας. Αφαιρέστε το πλέγμα.
- Χρησιμοποιώντας το βουρτσάκι, καθαρίστε το κοπτικό σύστημα και το εσωτερικό μέρος της ξυριστικής κεφαλής. Ωστόσο, μην καθαρίζετε το πλέγμα ξυρίσματος με το βουρτσάκι γιατί μπορεί να προκληθεί ζημιά.

Διατηρείστε την ξυριστική σας μηχανή σε άριστη κατάσταση

Κάθε τέσσερις εβδομάδες περίπου, να καθαρίζετε το κοπτικό σύστημα με τα ειδικά καθαριστικά της Braun. Ρίξτε μια σταγόνα από ελαφρύ λάδι μηχανής στο κόπτη μακρών τριχών και στο πλέγμα (d).

Αντικατάσταση ανταλλακτικών

Για να έχετε 100% τέλειο αποτέλεσμα, το πλέγμα ξυρίσματος και το κοπτικό σύστημα θα πρέπει να αντικαθίστανται τουλάχιστον κάθε 18 μήνες, ή όταν τα εξαρτήματα έχουν φθαρεί. Αλλάξτε και τα δυο ανταλλακτικά ταυτόχρονα για πιο βαθύ ξύρισμα με λιγότερους ερεθισμούς. (Πλέγμα ξυρίσματος και Κοπτικό σύστημα – σειρά 1000).

Συντήρηση των μπαταριών

Για να διατηρήσετε τη μέγιστη απόδοση των επαναφορτιζόμενων μπαταριών, η ξυριστική μηχανή θα πρέπει να αποφορτίζεται πλήρως (χρησιμοποιώντας την στο ξύρισμα) περίπου κάθε 6 μήνες. Μετά επαναφορτίστε τη μηχανή πλήρως. Μην αφήνετε τη συσκευή εκτεθειμένη σε θερμοκρασίες άνω των 50 °C για μεγάλες χρονικές περιόδους.

Σημείωση για την προστασία του περιβάλλοντος

Η συσκευή αυτή περιέχει επαναφορτιζόμενες μπαταρίες νικελίου-υδριδίου. Για την προστασία του περιβάλλοντος μην πετάξετε τη συσκευή στα οικιακά απορρίμματα όταν φτάσει το τέλος της χρήσιμης ζωής της. Ανοίξτε το περίβλημα όπως φαίνεται στη σελίδα 47, αφαιρέστε τις





μπαταρίες και παραδώστε τις στο κατάστημα λιανικής πώλησης ή στα κατάλληλα σημεία συλλογής σύμφωνα με τους εθνικούς ή τοπικούς κανονισμούς.

Το προϊόν υπόκειται σέ τροποποίηση χωρίς προειδοποίηση.

Αυτό το προϊόν ανταποκρίνεται στις απαιτήσεις της Ευρωπαϊκής κοινότητας, όπως αυτές αναφέρονται στην οδηγία του Συμβουλίου 89/336/ΕΟΚ και με τις διατάξεις περί Χαμηλών Ηλεκτρικών Τάσεων (73/23 ΕΟΚ).



Ηλεκτρικές απαιτήσεις είναι τυπωμένες επάνω στη συσκευή.

Στο τέλος της λειτουργικής ζωής του προϊόντος, παρακαλώ πετάξτε το στα ειδικά σημεία που παρέχονται στη χώρα σας.

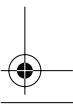
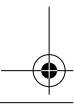
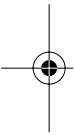

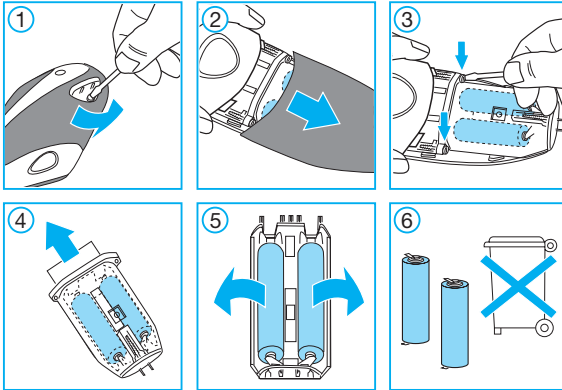

Deutsch

Akku-Entsorgung am Ende der Lebensdauer des Gerätes

English

Battery removal at the end of the product's useful life

Français

Retrait des batteries à la fin de la durée de vie du produit

Español

Extracción de la pila al finalizar la vida útil del producto

Português

Remoção da bateria no fim da vida útil do produto

Italiano

Eliminazione delle batterie alla fine del ciclo di vita del prodotto

Nederlands

Het verwijderen van batterijen aan het eind van de nuttige levensduur van het apparaat

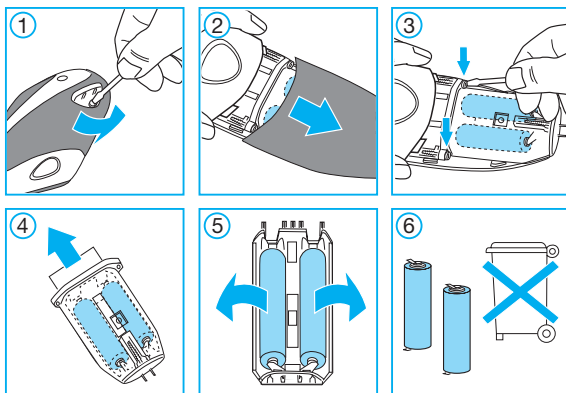

Dansk

Udtagelse af batteriet efter endt levetid

Norsk

Fjerning av batteriet ved slutten av apparatets levetid

Svenska

Att avlägsna batteriet när produkten är uttjänt

Suomi

Akun irrottaminen laitteen käyttöiän loputtua

Türkçe

Cihazın ömrü bittiğinde pili çıkarma

Ελληνικά

Για να βγάλετε τη μπαταρία μετά τη χρήσιμη ζωή της



Deutsch

Garantie

Als Hersteller übernehmen wir für dieses Gerät – nach Wahl des Käufers zusätzlich zu den gesetzlichen Gewährleistungsansprüchen gegen den Verkäufer – eine Garantie von 2 Jahren ab Kaufdatum. Innerhalb dieser Garantiezeit beseitigen wir nach unserer Wahl durch Reparatur oder Austausch des Gerätes unentgeltlich alle Mängel, die auf Material- oder Herstellungsfehlern beruhen. Die Garantie kann in allen Ländern in Anspruch genommen werden, in denen dieses Braun Gerät von uns autorisiert verkauft wird.

Von der Garantie sind ausgenommen: Schäden durch unsachgemäßen Gebrauch (Knickstellen an der Scherfolie, Bruch), normaler Verschleiß (z.B. Scherfolie oder Klingenblock) sowie Mängel, die den Wert oder die Gebrauchstauglichkeit des Gerätes nur unerheblich beeinflussen. Bei Eingriffen durch nicht von uns autorisierte Braun Kundendienstpartner sowie bei Verwendung anderer als Original Braun Ersatzteile erlischt die Garantie.

Im Garantiefall senden Sie das Gerät mit Kaufbeleg bitte an einen autorisierten Braun Kundendienstpartner. Die Anschrift für Deutschland können Sie kostenlos unter 00800/27 28 64 63 erfragen.

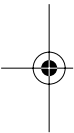

English

Guarantee

We grant 2 years guarantee on the product commencing on the date of purchase. Within the guarantee period we will eliminate, free of charge, any defects in the appliance resulting from faults in materials or workmanship, either by repairing or replacing the complete appliance as we may choose.

This guarantee extends to every country where this appliance is supplied by Braun or its appointed distributor.

This guarantee does not cover: damage due to improper use, normal wear and tear (e.g. shaver foil or cutter block) as well as defects that have a negligible effect on the value or operation of the appliance. The guarantee becomes void if repairs are undertaken by unauthorised persons and if original Braun parts are not used.

To obtain service within the guarantee period, hand in or send the complete appliance with your sales receipt to an authorised Braun Customer Service Centre.

For UK only:

This guarantee in no way affects your rights under statutory law.

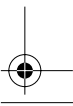
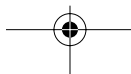
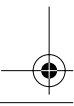



Français

Garantie

Nous accordons une garantie de 2 ans sur ce produit, à partir de la date d'achat. Pendant la durée de la garantie, Braun prendra gratuitement à sa charge la réparation des vices de fabrication ou de matière en se réservant le droit de décider si certaines pièces doivent être réparées ou si l'appareil lui-même doit être échangé.

Cette garantie s'étend à tous les pays où cet appareil est commercialisé par Braun ou son distributeur exclusif.

Cette garantie ne couvre pas: les dommages occasionnés par une utilisation inadéquate, l'usure normale (par exemple, grille et bloc-couteaux) ainsi que les défauts d'usure qui ont un effet négligeable sur la valeur ou l'utilisation de l'appareil. Cette garantie devient caduque si des réparations ont été effectuées par des personnes non agréées par Braun et si des pièces de rechange ne provenant pas de Braun ont été utilisées.

Pour toute réclamation intervenant pendant la période de garantie, retournez ou rappez l'appareil ainsi que l'attestation de garantie à votre revendeur ou à un Centre Service Agréé Braun.

Appelez au 01.47.48.70.00 pour connaître le Centre Service Agréé Braun le plus proche de chez vous.

Clause spéciale pour la France

Outre la garantie contractuelle exposée ci-dessus, nos clients bénéficient de la garantie légale des vices cachés prévue aux articles 1641 et suivants du Code civil.

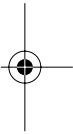

Español

Garantía

Braun concede a este producto 2 años de garantía a partir de la fecha de compra. Dentro del periodo de garantía, subsanaremos, sin cargo alguno, cualquier defecto del aparato imputable tanto a los materiales como a la fabricación, ya sea reparando, sustituyendo piezas, o facilitando un aparato nuevo según nuestro criterio.

La garantía no ampara averías por uso indebido, funcionamiento a distinto voltaje del indicado, conexión a un enchufe inadecuado, rotura, desgaste normal (p.ej. la lámina o bloque de cuchillas) por el uso que causen defectos o una disminución en el valor o funcionamiento del producto.

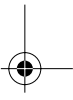
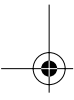



La garantía perderá su efecto en caso de ser efectuadas reparaciones por personas no autorizadas, o si no son utilizados recambios originales de Braun.

La garantía solamente tendrá validez si la fecha de compra es confirmada mediante la factura o el albarán de compra correspondiente.

Esta garantía tiene validez en todos los países donde este producto sea distribuido por Braun o por un distribuidor asignado por Braun.

En caso de reclamación bajo esta garantía, diríjase al Servicio de Asistencia Técnica de Braun más cercano.

Solo para España

Servicio al consumidor: Para localizar a su Servicio Braun más cercano o en el caso de que tenga Vd. alguna duda referente al funcionamiento de este producto, le rogamos contacte con el teléfono de este servicio 901 11 61 84.

Português

Garantia

Braun concede a este produto 2 anos de garantia a partir da data de compra. Dentro do período de garantia qualquer defeito do aparelho, devido aos materiais ou ao seu fabrico, será reparado, substituindo peças ou trocando por um aparelho novo segundo o nosso critério, sem qualquer custo.

A garantia não cobre avarias por utilização indevida, funcionamento a voltagem diferente da indicada, ligação a uma tomada de corrente eléctrica incorrecta, ruptura, normal utilização e desgaste (ex: rede e bloco de lâminas) por utilização que causem defeitos ou diminuição da qualidade de funcionamento do produto. A garantia perderá o seu efeito no caso de serem efectuadas reparações por pessoas não autorizadas ou se não forem utilizados acessórios originais Braun.

A garantia só é válida se a data de compra fôr confirmada pela apresentação da factura ou documento de compra correspondente.

Esta garantia é válida para todos os países onde este produto seja distribuído por Braun ou por um distribuidor Braun autorizado.

No caso de reclamação ao abrigo de garantia, dirija-se ao Serviço de Assistência Técnica Oficial Braun mais próximo.

Só para Portugal

Apoio ao consumidor: Para localizar o seu Serviço Braun mais próximo ou no caso de surgir alguma dúvida relativamente ao funcionamento deste produto, contacte por favor este serviço pelo telefone 808 20 00 33.

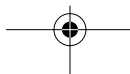

Italiano

Garanzia

Braun fornisce una garanzia valevole per la durata di 2 anni dalla data di acquisto.

Nel periodo di garanzia verranno eliminati, gratuitamente, i guasti dell'apparecchio conseguenti a difetti di fabbrica o di materiali, sia riparando il prodotto sia sostituendo, se necessario, l'intero apparecchio.

Tale garanzia non copre: i danni derivanti dall'uso improprio del prodotto, la normale usura (ad esempio di lamina o blocco coltelli) conseguente al funzionamento dello stesso, i difetti che hanno un effetto trascurabile sul valore o sul funzionamento dell'apparecchio.

La garanzia decade se vengono effettuate riparazioni da soggetti non autorizzati o con parti non originali Braun.

Per accedere al servizio durante il periodo di garanzia, è necessario consegnare o far pervenire il prodotto integro, insieme allo scontrino di acquisto, ad un centro di assistenza autorizzato Braun.

Contattare il numero 02/6678623 per avere informazioni sul Centro di assistenza autorizzato Braun più vicino.

Nederlands

Garantie

Op dit produkt verlenen wij een garantie van 2 jaar geldend vanaf datum van aankoop. Binnen de garantieperiode zullen eventuele fabricagefouten en/of materiaal fouten gratis door ons worden verholpen, hetzij door reparatie, vervanging van onderdelen of omruilen van het apparaat.

Deze garantie is van toepassing in elk land waar dit apparaat wordt geleverd door Braun of een officieel aangestelde vertegenwoordiger van Braun.

Beschadiging ten gevolge van onoordeelkundig gebruik, normale slijtage (bijv. aan scheerblad of messenblok) en gebreken die de werking of waarde van het apparaat niet noemenswaardig beïnvloeden vallen niet onder de garantie. De garantie vervalt bij reparatie door niet door ons erkende service-afdelingen en/of gebruik van niet originele Braun onderdelen.

Om gebruik te maken van onze service binnen de garantieperiode, dient u het complete apparaat met uw aankoopbewijs af te geven of op te sturen naar een geautoriseerd Braun Customer Service Centre.

Bel 0800-gillette voor een Braun Customer Service Centre bij u in de buurt.



Dansk

Garanti

Braun yder 2 års garanti på dette produkt gældende fra købsdatoen. Inden for garantiperioden vil Braun for egen regning afhjælpe fabrikations- og materialefejl efter vort skøn gennem reparation eller ombytning af apparatet. Denne garanti gælder i alle lande, hvor Braun er repræsenteret.

Denne garanti dækker ikke skader opstået ved fejlbetjening, normalt slid (f.eks. skærebled og lamelkniv) samt fejl, som har ringe effekt på apparatets værdi eller funktionsdygtighed. Garantien bortfalder ved reparationer udført af andre end de af Braun anviste reparatører og hvor originale Braun reservedele ikke er anvendt.

Ved service inden for garantiperioden afleveres eller indsendes hele apparatet sammen med købsbevis til et autoriseret Braun Service Center.

Ring 7015 0013 for oplysning om nærmeste Braun Service Center.

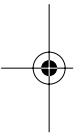

Norsk

Garanti

Vi gir 2 års garanti på produktet gjeldende fra kjøpsdato. I garantitiden vil vi gratis rette eventuelle fabrikkasjons- eller materialfeil, enten ved reparasjon eller om vi finner det hensiktsmessig å bytte hele produktet. Denne garanti er gyldig i alle land der Braun eller Brauns distributør selger produktet.

Denne garantien dekker ikke: skader på grunn av feil bruk, normal slitasje (f.eks. på skjærebled eller lamelkniven) eller skader som har ubetydelig effekt på produktets verdi og virkemåte sitat slutt. Garantien bortfaller dersom reparasjoner utføres av ikke autorisert person eller hvis andre enn originale Braun reservedeler benyttes.

For service i garantitiden skal hele produktet leveres eller sendes sammen med kopi av kjøpskvittering til nærmeste autoriserte Braun Serviceverksted.

Ring 88 02 55 03 for å bli henvist til nærmeste autoriserte Braun serviceverksted.

NB

For varer kjøpt i Norge har kunden garanti i henhold til NEL's Leveringsbetingelser.

52

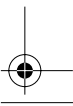
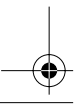



Svenska

Garanti

Vi garanterar denna produkt för två år från och med inköpsdatum. Under garantitiden kommer vi utan kostnad, att avhjälpa alla brister i apparaten som är hänförliga till fel i material eller utförande, genom att antingen reparera eller byta ut hela apparaten efter eget gottfinnande.

Denna garanti gäller i alla länder där denna apparat levereras av Braun eller deras auktoriserade återförsäljare.

Denna garanti gäller inte: skada på grund av felaktig användning, normalt slitage (t.ex. skärblad och saxhuvud) eller skador som har en försumbar effekt på värdet eller apparatens funktion. Garantin upphör att gälla om reparationer utförs av icke behörig person eller om Brauns originaldelar inte används.

För att erhålla service under garantitiden skall den kompletta apparaten lämnas in tillsammans med inköpskvittot, till ett auktoriserat Braun verkstad.

Ring 020-21 33 21 för information om närmaste Braun verkstad.

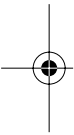

Suomi

Takuu

Tälle tuotteelle myönnämme 2 vuoden takuun ostopäivästä lukien Suomessa voimassa olevien alan takuehtojen TE90 mukaan. Takuuajana korvataan veloituksetta kaikki viat, jotka aiheutuvat materiaali- tai valmistusvirheestä. Korvaus tapahtuu harkintamme mukaan korjaamalla, vaihtamalla viallinen osa tai vaihtamalla koko laite uuteen. Takuu on voimassa kaikkialla maailmassa sillä edellytyksellä, että laitetta myydään ko. maassa Braunin tai virallisen maahantuojan toimesta.

Takuun piiriin eivät kuulu viat, jotka johtuvat virheellisestä käytöstä tai normaalista kulumisesta (esim. teräverkko tai leikkuuterä). Takuu ei myöskään kata sellaisia vikoja, jotka eivät merkittävästi vaikuta laitteen arvoon tai toimintaan. Takuun voimassaolo lakkaa, jos laitetta korjataan muualla kuin valtuutetussa Braun-huoltoliikkeessä tai jos laitteessa käytetään muita kuin alkuperäisiä varaosia.

Yksilöity ostokuitti riittää takuun voimassaolon osoittamiseksi.

Lisätietoa takuuseen liittyvistä asioista saa asiakaspalvelukeskuksestamme numerosta 020-377 877.

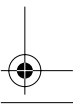
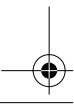



Ελληνικά

Εγγύηση

Παραχωρούμε δύο χρόνια εγγύηση, στο προϊόν, ξεκινώντας από την ημερομηνία αγοράς.

Μέσα στην περίοδο εγγύησης καλύπτουμε, χωρίς χρέωση, οποιαδήποτε ελάττωμα προερχόμενο από κακή κατασκευή ή κακής ποιότητας υλικό, είτε επισκευάζοντας είτε αντικαθιστώντας ολόκληρη τη συσκευή σύμφωνα με την κρίση μας.

Αυτή η εγγύηση ισχύει σε όλες τις χώρες που πωλούνται τα προϊόντα Braun.

Αυτή η εγγύηση δεν καλύπτει: ζημιά που να οφείλεται σε λανθασμένη χρήση, σε φθορά από φυσιολογική χρήση (π.χ. πλέγμα ή μαχαίρι) όπως και ζημιές που έχουν αμελητέα επίδραση στην αξία ή στη χρήση της συσκευής.

Η εγγύηση ακυρώνεται αν έχουν γίνει επισκευές από μη εξουσιοδοτημένα άτομα ή δεν έχουν χρησιμοποιηθεί γνήσια ανταλλακτικά Braun.

Για να επιτύχετε σέρβις μέσα στην περίοδο της εγγύησης, παραδώστε ή στείλτε την συσκευή με την απόδειξη αγοράς σε ένα Εξουσιοδοτημένο Κατάστημα Σέρβις της Braun.



Καλέστε στο 01-9478700 για να πληροφορηθείτε για το πλησιέστερο Εξουσιοδοτημένο Κατάστημα Σέρβις της Braun.

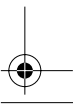
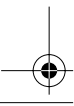
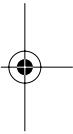

**Garantie/
Kundendienststellen**

**Garantie and
Service Centers**

**Bureaux de garantie et
centrales service après-vente**

**Oficinas de garantia y
oficinas centrales del servicio**

**Entidade de garantia e
centros de serviço**

**Uffici e sede centrale del
servizio clienti**

**Garantiebureaux en
service-centrales**

**Garantikontorer og
centrale serviceafdelinger**

Garanti og servicecenter

**Servicekontor och centrala
kundtjänstplatser**

**Asiakaspalvelu ja tekninen
neuvonta**

**Garanti bürolari ve merkezi
servis yerleri**

**Εγγύηση και Εργαστήριο
επισκευών**

Deutschland

Gillette Gruppe Deutschland
GmbH&Co.ohG
Braun Kundendienst
Bitte erfragen Sie das
nächstliegende
Braun Service Center unter
☎ 00800 / 27 28 64 63

Austria

Gillette Gruppe Österreich
Braun Kundendienst
Bitte erfragen Sie das
nächstliegende
Braun Service Center unter
☎ 00800 / 27 28 64 63

Argentina

Central Reparadora
de Afeitadoras S. A.,
Av. Santa Fe 5278,
1425 Capital Federal,
☎ 0800 44 44 553

Australia

Gillette Australia Pty. Ltd.,
Scoresby, 5 Caribbean Drive
Melbourne, Victoria 3179,
☎ 1 800 641 820

Bahrain

Yaquby Stores,
Bab ALBahrain,
P.O. Box 158,
Manama,
☎ 02-28 88 7

Barbados

Dacosta Mannings Inc.,
P.O. Box 176,
Pier Head,
Bridgetown,
☎ 431-8700

Belarus

Electro Service & Co LLC,
Chernyshevskogo str. 10 A,
220015 Minsk,
☎ 2 85 69 23

Belgium

Gillette Group Belgium NV,
J. E. Mommaertsiaan 18 A,
1831 Diegem,
☎ 02-71 19 104

Bermuda

Gibbons Company
21 Reid Street
P.O. Box HM 11
Hamilton
☎ 295 00 22

Brasil

Fixnet Servicios & Comércio
Ltda.
R. Gaspar Fernandes, 377
São Paulo – SP,
☎ 0800 16 26 27

Bulgaria

12, Hristo Botev str.
Sofia, Bulgaria
☎ + 359 2 528 988

Canada

Gillette Canada Company,
Braun Consumer Service
4 Robert Speck Parkway,
Mississauga L4Z 4C5,
Ontario,
☎ 1 800 387 6657

Česká Republika

PH SERVICE sro.,
V Mezihori 2,
18000 Praha 8,
☎ 266 310 574

Chile

Viseelec,
Braun Service Center Chile,
Av. Concha y Toro #4399,
Puente Alto,
Santiago,
☎ 02 288 25 18

China

Gillette (Shanghai)
Sales Co. Ltd.
550 Sanlin Road, Pudong,
Shanghai 200124,
☎ 00 86 21 5849 8000

Colombia

Gillette de Colombia S.A.,
Calle 100 No. 9A - 45 Piso 3.
Bogotá, D.C.,
☎ 01 8000 5 27286

Croatia

Iskra elektronika d.o.o.,
Bozidara Magovca 63,
10020 Zagreb,
☎ 1-6 60 17 77

Cyprus

Kyriakos Papavasiliou Trading
70, Kennedy Ave.,
1663 Nicosia,
☎ 02 314111

Denmark

Gillette Group Danmark A/S,
Tegholm Allé 15,
2450 København SV,
☎ 70 15 00 13

Djibouti (Republique de)

Ets. Nouraddine,
Magasin de la Seine,
12 Place du 27 Juin,
B.P. 2500,
Djibouti,
☎ 35 19 91

Egypt

Uni Trade,
25 Makram Ebied Street,
P.O. Box 7607,
Cairo,
☎ 02-2740652

España

Braun Española S.A.,
Braun Service,
Enrique Granados, 46,
08950 Esplugues de Llobregat
(Barcelona),
☎ 901 11 61 84

Estonia

Servest Ltd.,
Raua 55, EE 10152 Tallin,
☎ 627 87 32

France

Groupe Gillette France -
Division Braun,
9, Place Marie Jeanne Bassot,
92693 Levallois Perret Cédex,
☎ (1) 4748 70 00,
Minitel 3615 code Braun.

Great Britain

Gillette Group UK Ltd.,
Braun Consumer Service,
Aylesbury Road,
Thame OX9 3AX
Oxfordshire
☎ 1800 783 70 10

Greece

Berson S.A.,
47, Agamemnonos,
17675 Kallithea Athens,
☎ (210)-9 47 87 00

Guadeloupe

Ets. André Haan S.A.,
Zone Industrielle
B.P. 335,
97161 Pointe-à-Pitre,
☎ 26 68 48

Hong Kong

Audio Supplies Company,
Room 506,
St. George Building,
2 ICE House Street,
Hong Kong,
☎ (852) 2524 9377

Hungary

Gillette Group Hungary
Kereskedelmi Kft.,
1037 Budapest,
Szépvölgyi út 35-37
☎ 1801-3800

Iceland

Verslunin Pfaff h.f.,
Grensasvegur 13,
Box 714, 121 Reykjavik,
☎ 53 32 22

India

Braun Division,
c/o Gillette Div. Op. Pvt. Ltd.,
34, Okhla Industrial Estate,
New Delhi 110 020,
☎ 11 68 30 218

Iran

Tehran Bouran Company
145 Ghaem Magham Farahani
Tehran
☎ +982 18 31 27 66

Ireland (Republic of)

Gavin's Electronics,
83-84, Lower Camden Street,
Dublin 2,
☎ 1800 509 448

Israel

S. Schestowitz Ltd.,
8 Shacham Str.,
Tel-Aviv, 49517,
☎ 1 800 335 959

Italia

Servizio Consumatori Braun
Gillette Group Italy S.p.A.,
Via G.B. Pirelli, 18,
20124 Milano,
☎ 02 / 6678623

Jordan

Interbrands
Wadi Al-Sir, Adwiat alhekma
St. Mekadabi bld.
Amman
☎ +692 582 75 67

Kenya

Radbone-Clark Kenya Ltd.,
P.O. Box 40833,
Mombasa Road,
Nairobi,
☎ 2 82 12 76

Korea

Gillette Korea Ltd.
144-27 Samsung-dong,
Kangnam-ku,
Seoul, Korea,
☎ 080-920-6000

Kuwait

Union Trading Company,
Braun Service Center,
P.O. Box 28 Safat,
Safat Code 13001,
Kuwait,
☎ 04 83 32 74

Latvia

Latintertehservice Co.,
72 Bullu Street, House 2,
Riga 1067,
☎ 2 40 39 11

Lebanon

Magnet SAL - Fattal HLDG,
Sin EL Fil – Jisr EL Wati
Beirut,
☎ +961 148 52 50

Lithuania

Elektronas AB,
Kareivių 6,
LT 2600 Vilnius,
☎ 277 76 17

Luxembourg

Sogel S.A.,
Rue de l'industrie 7,
L-2543 Windhof,
☎ 4 00 50 51

Malaysia

Exact Quality
Lot 24 Rawang Housing
& Industrial Estate
Mukim Rawang,
PO No 210
48,000 Rawang
Selangor Malaysia
☎ (603) 6091 4343

Malta

Kind's,
287, Republic Street,
Valletta VLT04,
☎ 24 71 18

Morocco

FMG
depot TMTA
Rue Chefchaouen, Oukacha
Casablanca
☎ +212 022 66 47 69

Martinique

Decius Absalon,
23 Rue du Vieux-Chemin,
97201 Fort-de-France,
☎ 73 43 15

Mauritius

J. Kalachand & Co. Ltd.,
DBM Industrial Estate,
Stage 11,
P.O.B. 634
Plaine Lauzun,
☎ 2 12 84 10

Mexico

Gillette Manufactura,
S.A. de C.V./
Gillette Distribuidora,
S.A. de C.V.
Atomo No. 3
Parque Industrial Naucalpan
Naucalpan de Juarez
Estado de México, C.P. 53370
☎ 01-800-508-58-00

Nederland

Gillette Groep Nederland BV,
Visseringlaan 22,
2288 ER Rijswijk,
☎ 0 800-445 53 88

Netherlands Antilles

Rupchand Sons n.v. (ram's),
Front Street 67, P.O. Box 79
St. Maarten, Philipsburg
☎ 052 29 31

New Zealand

Key Service Ltd.,
69 Druces Road.,
Manakau City,
☎ 09-262 58 38

Nippon

Gillette Japan Inc.,
Queens Tower, 13F
3-1, Minato Mirai 2-Chome
Nishi-Ku,
Yokohama 220-6013
Japan
☎ 045-680 37 00

Norge

Gillette Group Norge AS,
Niils Hansensvei 4,
P.O. Box 79 Bryn,
0667 Oslo,
☎ 022-72 88 10

Oman (Sultanate of)

Naranjee Hirjee & Co.,
10 Ruwi High,
P.O. Box 9, Muscat 113,
☎ 703 660

Pakistan

Gillette Pakistan Limited,
Dr. Ziauddin Ahmend Road,
Karachi 74200,
☎ 21 56 88 930

Paraguay

Paraguay Trading S.A.,
Avda. Artigas y Cacique
Cara Cara,
Asunción,
☎ 21203350-48/46

Philippines

Gillette Philippines Inc.,
Corporate Corner Commerce
Avenues
20/F Tower 1,
IL Corporate Centre
1770 Muntinlupa city
☎ 02-771071 02-06/-16

Poland

Gillette Group Poland
Sp.Z o.o.,
ul. Domaniewska 41,
02-672 Warszawa,
☎ 22 548 89 74

Portugal

Grupo Gillette Portugal, Lda.,
Braun Service,
Rua Tomás da Fonseca,
Torre G-2ª A,
1600-209 Lisboa,
☎ 808 2 000 33

Réunion

Dindar Confort,
Rte du Gymnase,
Boite Postale 278,
97940 St. Clotilde,
☎ 026 92 32 03

Romania

Gillette Romania srl.
Calea Floreasca nr. 133-137
et 1, sect 1,
714011 Bucuresti
☎ 01-2319656

Russia

RTC Sovinservice,
Rusakovskaya 7,
107140 Moscow,
☎ (095) 264 41 61

Saudi Arabia

AL Naghi company
AL Madinah road
opposite to Fetih center,
Al Forsan
P.O. Box: 269
21411 Jeddah
☎ 02-651 8670

Schweiz/Suisse/Svizzera

Telion AG, Rütistrasse 26,
8952 Schlieren,
☎ 0844-88 40 10

Singapore (Republic of)

Beste (S) Pte. Ltd.,
No. 6 Tagore Drive,
03-04 Tagore Industrial
Building,
Singapore 787623,
☎ (65) 6552 2422

Slovakia

Techno Servis Bratislava,
Baizova 11/A,
82108 Bratislava,
☎ (02) 55 56 37 49

Slovenia

Iskra Prins d.d.
Rozna dolina c. IX/6
1000 Ljubljana,
☎ 386 01 476 98 00

South Africa (Republic of)

Fixnet After Sales Service,
159 Queen Street,
Kensington South,
P.O. Box 751770,
Johannesburg 2094,
Kensington South,
☎ 11 615 6765

St. Maarten

Rupchand Sons n.v. (ram's),
P.O. Box 79, Philipsburg,
Netherlands Antilles,
☎ 52 29 31

St. Thomas

Boolchand's Ltd.,
31 Main Street,
P.O. Box 5667,
00803 St. Thomas,
US Virgin Islands,
☎ 340 776 0302

Suomi

Gillette Group Finland Oy,
P.O. Box 9,
Niittykatu 8, PL 9,
02200 Espoo,
☎ 09-45 28 71

Sverige

Gillette Group Sverige AB,
Dept. Sweden,
Stockholm Gillette
Räsundavägen 12,
Box 702,
16927 Solna,
☎ 020-21 33 21

Syria

Ahmed Hadaya Company
Hadaya building
Ain Keresh
Unisyria, P.O. Box 35002,
Damascus,
☎ 963 011-231433

Taiwan

Audio & Electr. Supplies Ltd.,
Brothers Bldg., 10th Floor,
85 Chung Shan N Rd., Sec. 1,
Taipei (104),
☎ (886) 02 2523 3283

Thailand

Gillette Thailand Ltd.,
175 South Sathorn Road,
Tungmahamek, Sathorn,
11/1 Floor,
Sathorn City Tower
Bangkok 10520
☎ (66) 2344 9191/ Exten.
9135

Tunesie

Generale d'Equipement
Industr., (G.E.I.)
34 rue du Golfe Arabe,
Tunis, 2000,
☎ 171 68 80

Turkey

Gillette Sanayi ve Ticaret A.S.,
Polaris Is Merkezi,
Ahi Evran Cad., No:1,
80870 Maslak, Istanbul,
☎ 0212-473 75 85

Ukraine

Importbytsservice-Ukraine
Hlybochytska str.53, Kyiv
☎ 380-44-417-24-15

United Arab Emirates

The New Store LLC,
Burjman shopping mall,
Bur Dubai
Dubai,
☎ +9714 359 19 19

Uruguay

Driva S.A.,
Marcellino Sosa 2064,
11800 Montevideo,
☎ 2 924 95 76

USA

The Gillette Company
Braun Consumer Service,
1, Gillette Park 4k-16,
Boston, MA 02127-1096,
☎ 1-800-272-8611

Venezuela

Gillette de Venezuela S.A.,
Av. Blandin,
Centro San Ignacio
Torre Copérnico, Piso 5
La Castellana, Caracas
☎ 0800-4455388

Yemen (Republic of)

Saba Stores for Trading,
26th September Street,
P.O. Box 5278,
Taiz,
☎ 4-25 23 88

Yugoslavia

BG Elektronik,
Bulevar kralja Aleksandra 34,
11000 Beograd,
☎ 11 3240 030



FreeControl 1775

**Garantiekarte
Guarantee Card
Carte de garantie
Tarjeta de garantía
Cartão de garantia
Carta di garanzia
Garantiebewijs
Garantibevis
Κόρβεvis
Takuukortti
Κάρτα εγγυήσεως**

FreeControl 1775

**Registrierkarte
Registration Card
Carte de contrôle
Tarjeta de registro
Cartão de registo
Cartolina di registrazione
Registratiekaart
Registreringskort
Κάρτα καταχωρήσεως**



Service notes

Name und vollständige Anschrift des Käufers
Name and full address of purchaser
Nom et adresse complète de l'acheteur
Nombre y dirección completa del comprador
Nome e direção completa do comprador
Nome e indirizzo completo dell'acquirente
Naam en volledig adres van de koper
Kjøperens navn og adresse
Köparens namn och fullständiga adress
Όνομα και πλήρης διεύθυνσις αγοραστού

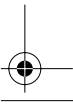
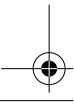



Kaufdatum
Date of purchase
Date d'achat
Fecha de adquisición
Data de compra
Data d'acquisto
Koopdatum
Kjøpsdato
Inköpsdatum
Ημερομηνία αγοράς

Kaufdatum
Date of purchase
Date d'achat
Fecha de adquisición
Data de compra
Data d'acquisto
Koopdatum
Købsdato
Kjøpsdato
Inköpsdatum
Ostopäivä
Ημερομηνία αγοράς

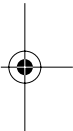
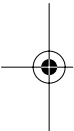

Stempel und Unterschrift des Händlers
Stamp and signature of dealer
Cachet et signature du commerçant
Sello y firma del proveedor
Carimbo e assinatura do vendedor
Timbro e firma del negozio
Stempel en handtekening van de handelaar
Stempel og underskrift av forhandleren
Återförsäljares stämpel och underskrift
Σφραγίδα και υπογραφή καταστήματος

Stempel und Unterschrift des Händlers
Stamp and signature of dealer
Cachet et signature du commerçant
Sello y firma del proveedor
Carimbo e assinatura do vendedor
Timbro e firma del negozio
Stempel en handtekening van de handelaar
Forhandlerens stempel og underskrift
Stempel og underskrift av forhandleren
Återförsäljares stämpel och underskrift
Myyjän leima ja allekirjoitus
Σφραγίδα και υπογραφή καταστήματος

