

Repair Manual



R 1150 GS

**BMW Motorrad
After Sales**

Publisher

© BMW Motorrad
After Sales
UX-VS-2

All rights reserved. Not to be reprinted, translated or duplicated either wholly or in part without prior written permission.

Errors and omissions excepted; subject to technical amendment.

Printed in Germany 02/00

Order number 01 79 0 021 120

Introduction

This Repair Manual will help you to perform all the main maintenance and repair work correctly and efficiently. It should be consulted regularly by workshop personnel as an addition to the practical and theoretical knowledge obtained in Training School courses. It is a contribution towards achieving even higher Service quality.

A new issue of this repair manual will be published if amendments or additions (supplements) are needed. The latest issue date is shown in the header of the microfiche. Microfiches rendered invalid by the new issue should be destroyed without delay.

All information in both text and illustrations refers to motorcycles in standard condition or with genuine BMW accessories installed, and not to motorcycles which have been modified in any way to depart from the manufacturer's specification.

- The Repair Manual is structured in the logical sequence of the work to be performed: Removal, Disassembly, Repair, Assembly, Installation.
- The entire contents are divided into individual chapters, corresponding to the Construction Groups.

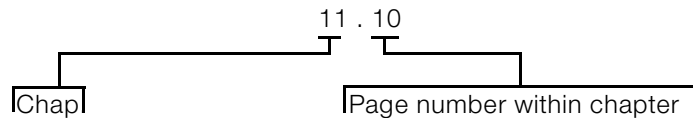

- Work to be performed during an Inspection is described in Group "00". The various inspection routines are numbered I, II, III and IV. This numbering is repeated in the work descriptions which follow, so that work can take place without interruption.
- Use of the BMW special tools needed for certain tasks is described in the work instructions.

If the need arises, repair instructions are also issued in the form of Service Information. This information is of course incorporated into the next issue of the Repair Manual. We also recommend you to consult the detailed illustrations on the Parts microfiches as an additional source of information.

BMW Motorrad
After Sales

Published by: BMW Motorrad
Hufelandstr. 6
D - 80937 München

All rights reserved. Not to be reprinted, translated or duplicated either wholly or in part without prior written permission.
Errors and omissions excepted; subject to technical amendment.
Printed in Germany

BMW Motorrad

Maintenance schedule

R 1100 S / R 850/1200 C / R 1150 GS



Customer _____ Licence plate No. _____		BMW Inspection at 1000 km (600 miles)	BMW Service every 10 000 km (6 000 miles)	BMW Inspection every 20 000 km (12 000 miles)	BMW Annual Service
Order No. _____ Mechanic's signature _____					
Read the fault code memory with the MoDiTeC		<input type="checkbox"/>	<input type="checkbox"/>	<input type="checkbox"/>	<input type="checkbox"/>
Change oil while at regular operating temperature and renew the oil filter element if motorcycle is used only for short journeys or at outside temperatures under 0°C (32 °F), every 3 months, but at least every 3 000 km (1 800 miles) *)		<input type="checkbox"/>	<input type="checkbox"/>	<input type="checkbox"/>	<input type="checkbox"/>
Change oil in gearbox while at operating temperature at least every 2 years*)				<input type="checkbox"/>	<input type="checkbox"/> every 2 years
Change oil in rear wheel drive while at regular operating temperature; if necessary, clean inductive sensor on rear wheel every 40 000 km (24 000 miles) or at least every 2 years *)		<input type="checkbox"/>		<input type="checkbox"/> 40 000 (24 000)	<input type="checkbox"/> every 2 years
Renew fuel filter *) normally every 40 000 km (24 000 miles), if fuel quality is poor every 20 000 km (12 000 miles)				<input type="checkbox"/> 40 000 (24 000)	
Check battery acid level, if necessary add distilled water Clean and grease the battery terminals, if necessary				<input type="checkbox"/>	<input type="checkbox"/>
Renew intake air filter element in very dusty or dirty operating conditions, renew the intake air filter element every 10 000 km (6 000 miles) or even more often if necessary *)				<input type="checkbox"/>	
Renew Poly-V belt *) renew Poly-V belt every 60 000 km (36 000 miles); do not adjust				<input type="checkbox"/> 60 000 (36 000)	
Check brake fluid level at front and rear			<input type="checkbox"/>	<input type="checkbox"/>	
Check operation of brake system and freedom from leaks; repair/replace items if nec. *)				<input type="checkbox"/>	
Examine brake pads and discs for wear, renew if necessary *)			<input type="checkbox"/>	<input type="checkbox"/>	
Change the brake fluid annually					<input type="checkbox"/>
Check clutch fluid level			<input type="checkbox"/>	<input type="checkbox"/>	
Change the clutch fluid at least every 2 years *)					<input type="checkbox"/> every 2 years
Check tightness of rear wheel studs		<input type="checkbox"/>			
Check rear wheel bearing play by tilting wheel				<input type="checkbox"/>	
Check swinging arm bearings (zero play); adjust if necessary *)		<input type="checkbox"/>		<input type="checkbox"/>	
Grease the side stand pivot		<input type="checkbox"/>	<input type="checkbox"/>	<input type="checkbox"/>	
Check function of side stand contact switch		<input type="checkbox"/>	<input type="checkbox"/>	<input type="checkbox"/>	<input type="checkbox"/>
Check condition of spark plugs			<input type="checkbox"/>		
Renew spark plugs				<input type="checkbox"/>	
Check security of cylinder head nuts		<input type="checkbox"/>			
Check/adjust valve clearances		<input type="checkbox"/>	<input type="checkbox"/>	<input type="checkbox"/>	
Check throttle cable for free movement, abrasion and kinking; renew if necessary *) Check cable play Check synchronisation and eliminate leaks *)		<input type="checkbox"/>	<input type="checkbox"/>	<input type="checkbox"/>	
Final inspection with road safety and functional check: – Condition of tyres and wheels, rims and spokes if applicable, tyre pressures – Lights and signalling equipment – Telltale and warning lights – Clutch, gear shift – Front and rear brakes, steering – Instruments – If necessary, test ride		<input type="checkbox"/>	<input type="checkbox"/>	<input type="checkbox"/>	<input type="checkbox"/>

*) **Charged as an additional item**

BMW Motorrad

Pre-delivery check

R 1100 S / R 850/1200 C / R 1150 GS



_____ Customer	_____ Licence plate No.	BMW Pre-delivery check
_____ Order No.	_____ Mechanic's signature	
Check the shipping crate for damage		<input type="checkbox"/>
Motorcycle: <ul style="list-style-type: none"> - unpack - install remaining items - inspect for damage - check that delivery is complete: <ul style="list-style-type: none"> tools documentation keys correct optional extras 		<input type="checkbox"/>
Fill and charge the battery (mark with charging date)		<input type="checkbox"/>
Check engine oil level when cold; add oil if necessary		<input type="checkbox"/>
Check headlight beam angle, adjust if necessary		<input type="checkbox"/>
Check security of rear wheel studs (comply with correct tightening torque)		<input type="checkbox"/>
Check tyre pressures		<input type="checkbox"/>
Fill fuel tank		<input type="checkbox"/>
Final inspection as functional check: <ul style="list-style-type: none"> - Clutch, gear shift - Front and rear brakes - Lights and signalling equipment, telltale and warning lights, instruments - Check operation of optional extras, ABS - If necessary, test ride 		<input type="checkbox"/>
Confirm pre-delivery check in Service and Technical Booklet		<input type="checkbox"/>
Final cleaning		<input type="checkbox"/>
Motorcycle handed over on:		

BMW Motorrad

Service data

R 1150 GS



Item	Desired value	Unit of measurement/ specification
Oil capacities		
Engine (with filter) (without filter)	3.75 (6.60) 3.50 (6.16)	litres (Imp. pints) litres (Imp. pints) [SI 11 048 90] Engine oil grade: brand-name HD oil for four-stroke spark-ignition engines, API classes SE, SF, SG; combination with CC or CD specification
Gearbox Initial filling/oil changes	approx. 1.0 (1.76) up to lower edge of filler hole	litres (Imp. pints) Brand-name hypoid gear oil, SAE class GL 5 SAE 90
Rear wheel drive Initial filling/oil changes	approx. 0.25 (0.44) oil level with bottom of filler neck	litres (Imp. pints) Brand-name hypoid gear oil, SAE class GL 5 SAE 90
Valve clearances		
Measured cold (max. 35 °C/95 °F)	Inlet: 0.15 (0.006) Exhaust: 0.30 (0.011)	mm (in) mm (in)
Ignition timing		
Static setting	adjust at TDC	
Spark plugs		
Electrode gap	0.8 (0.03)	mm (in)
Wear limit	1.0 (0.04)	mm (in)
Idle speed	1100± ⁵⁰	min ⁻¹
Throttle cable setting		
for cold-start (increased idle) speed for throttle (twistgrip) cable for divider cable	zero play app. 0.5 (0.02) zero play	mm (in) free travel
Brakes		
Minimum front pad thickness	1.0 (0.04)	DOT 4 brake fluid mm (in)
Minimum rear pad thickness	wear mark	
Minimum front disc thickness	4.5 (0.18)	mm (in)
Minimum rear disc thickness	4.5 (0.18)	mm (in)
Tyre pressures		
depending on load	front: 2.2 – 2.5 (31.3 – 35.6) rear: 2.5 – 2.9 (35.6 – 41.2)	bar (psi) bar (psi)
Tightening torques:		
Oil filter	11	Nm
Engine oil drain plug	32	Nm
Gearbox oil filler plug	30	Nm
Gearbox oil drain plug	30	Nm
Rear wheel drive oil filler/drain plug	23	Nm
Fuel tank to rear frame	21	Nm
Fuel pump unit to tank	6	Nm
Poly-V belt preload	8	Nm
Alternator to alternator carrier cover	20	Nm
Brake calliper mounting, front/rear	40	Nm
Rear wheel studs	initial torque 72 105	Nm Nm
Tightening cylinder heads Nut	slacken/20 180	Nm
M 10 screw	slacken/40	° tightening angle Nm
Locknut, valve adjusting screw	8	Nm
Cylinder head cover	8	Nm
Spark plugs	20	Nm

General table of contents

Group / Section

00 Maintenance and general instructions

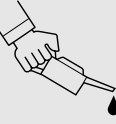

11 Engine

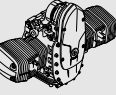

12 Engine electrics



13 Fuel preparation and control

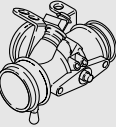

16 Fuel tank and lines



18 Exhaust system



21 Clutch

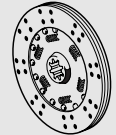

23 Transmission



31 Front forks



32 Steering

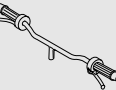

33 Rear wheel drive

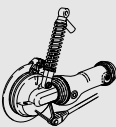

>> Next

Group / Section

34 Brakes



36 Wheels and tyres



46 Frame



51 Equipment



52 Seat



61 General electrical equipment



62 Instruments



63 Lights



<< Back

00 Maintenance and general instructions

Tightening torques and table of consumables
Pre-delivery check
Maintenance

Contents

Page

Tightening torques5
Table of operating fluids 12





Pre-delivery check	13
General view of crated motorcycle	13
Check the shipping crate for damage	14
In case of damage in Germany	14
In case of damage in importer markets	14
Unpacking the motorcycle	14
Inspecting motorcycle for damage	15
Checking that delivery is complete	15
Installing remaining items on motorcycle	16
Install the windscreen	16
Installing sump guard	17
Filling and charging the battery	18
Disengaging and raising the fuel tank	18
Filling and charging the battery	18
Checking engine oil when engine is cold, topping up if necessary	19
Checking headlight beam angle, adjusting if necessary	20
Checking tightness of rear wheel studs	20
Checking tyre pressures	20
Attaching adhesive label	20
Final inspection and function check	21
Final cleaning	21
Handing over the motorcycle	21

Maintenance	22
Key to maintenance intervals	22
Reading out MoDiTeC fault memory	22
(Inspections I, II, III and IV)	
Changing engine oil, replacing oil filter element	22
(Inspections I, II, III and IV)	
Changing oil in gearbox	23
(Inspections III and IV)	
or at the latest every 2 years	
Changing the oil in the rear wheel drive	23
(Inspections I, III and IV)	
Every 40,000 km (24,000 miles) or at the latest every 2 years	
Replacing fuel filter	24
(Inspection III)	
In normal operating conditions every 40,000 km (24,000 miles); if fuel quality is poor every 20,000 km (12,000 miles)	
Checking battery fluid level and topping up if necessary; cleaning and greasing the battery posts	26
(Inspections III and IV)	
Replacing intake air filter element	26
(Inspection III)	
In very dirty and dusty operating conditions, replace every 10,000 km (6,000 miles) or even more frequently if necessary	
Replacing Poly-V belt	27
(Inspection III)	
(every 60,000 km/36,000 miles)	
Checking brake system for correct operation and freedom from leaks; repairing/replacing if necessary	28
(Inspection III)	
Checking brake fluid level	28
(Inspections II and III)	
Front brake	28
Rear brake	28
Checking brake pads and discs for wear/replacing	29
(Inspections II and III)	
Checking front brake pad wear	29
Checking rear brake pad wear	29
Checking brake disc wear	29
Replacing brake pads, front brake	30
Replacing brake pads, rear brake	30





Changing brake fluid and bleeding brake system	31
Change the brake fluid annually (Inspection IV)	
Bleeding front brake circuit/changing brake fluid	31
Additional information for [ABS]	
Bleeding rear brake circuit/changing brake fluid	33
Checking clutch operating fluid level	34
(Inspections II and III)	
Changing the clutch fluid	34
(Inspections IV) at the latest every 2 years	
Checking tightness of rear wheel studs	35
(Inspection I)	
Checking rear wheel bearing play by tilting wheel	35
(Inspection III)	
Checking swinging arm bearings, adjusting if necessary	35
(Inspections I and III)	
Greasing the side stand pivot	36
(Inspections I, II and III)	
Checking function of side stand contact switch	36
(Inspections I, II, III and IV)	
Checking/replacing spark plugs	36
(Inspection II) check/(Inspection III) replace	
Tightening cylinder heads	37
(Inspection I)	
Checking/adjusting valve clearances	37
(Inspections I, II and III)	
Checking freedom of throttle cable, checking for chaffing and kinks, replacing if necessary	
Checking throttle-cable play	
Checking and adjusting idle speed and throttle-valve synchronisation	38
(Inspections I, II and III)	
Final inspection with road safety and functional check	39
(Inspections I, II, III and IV) Road safety check Roadworthiness check	

Tightening torques

Model	R 1150 GS
Connection	Nm
11 Engine	
Cylinder head	
Tightening sequence:	
1. Tighten cylinder head nuts (oiled) in diagonally opposite sequence	
1.1 Tighten all nuts to closing torque	20
1.2 Tighten all nuts to correct angle	90°
1.3 Tighten all nuts to correct angle	90°
2. M 10 screw	40
3. M 6 screw	9
After 1,000 km (600 miles), tighten cylinder head nuts in diagonally opposite sequence:	
1. Slacken one nut	
2. Tighten nut to initial torque	20
3. Tighten nut to wrench angle	180°
4. Slacken and retighten M 10 screw	40
Timing gear carrier to cylinder head	9
Bearing cap on rocker shaft	18
Locknut, valve adjusting screw	8
Cylinder head cover to cylinder head	8
Camshaft end cover to cylinder head	9
Air intake connection to cylinder head	9
Camshaft	
Chain sprocket to camshaft	65
Camshaft bearing cap	15
Alternator mount cover	
M 6 screw	9
M 8 screw	20
Auxiliary shaft	
Chain sprocket to crankshaft	10
Chainwheel to auxiliary shaft	70
Chain tensioner housing to engine block	9
Oil filter	
Oil filter	11
Oil drain plug	32

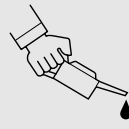



Model		R 1150 GS	
Connection		Nm	
11 Engine			
Oil pump			
Mesh filter basket to engine block		10	
Oil pump cover		9	
Pressure relief valve		42	
Oil pressure switch		30	
Oil cooler			
Cooling oil line to engine block		10	
Cooling oil line - banjo screw with oil vent valve		25	
Oil lines to oil cooler		25	
Oil cooler to bracket		9	
Oil cooler return line to engine block		35	
Oil cooler connection to crankcase		9	
Cylinders			
Tightening sequence:			
1. M 8 screw		20	
2. M 6 screw		9	
3. Chain guide rail pivot screw		18	
Timing chain			
Chain tensioner		32	
Connecting rod			
Big end cap	Closing torque	20	
	Wrench angle	80°	
Crankcase			
Tightening sequence:			
M 10 screw (oiled)	Initial torque	25	
	Wrench angle	90°	
M 8 screw (oiled)		22	
M 6 screw		9	
12 Engine electrics			
Starter motor to engine		20	
Starter cover to gearbox housing		7	
Positive lead to starter motor		10	
Alternator to alternator support cover		20	
Tensioning and retaining link to alternator		21	

Model	R 1150 GS	
Connection	Nm	
12 Engine electrics		
Spacer to alternator	21	
Positive lead to alternator	15	
Belt pulley to alternator Standard alternator 560 W Special alternator 700 W	Do not release 50	
Belt pulley to crankshaft	50	
Poly-V belt preload	8	
Spark plug	20	
13 Fuel preparation and control		
Temperature sensor, oil, in crankcase	25	
Temperature sensor, air, in air-filter housing	10	
16 Fuel tank and lines		
Fuel tank to rear frame	21	
Fuel pump assembly to tank	6	
18 Exhaust system		
Manifold to cylinder head	21	
Clamp for manifold	45 (apply Optimoly TA to clamp seat)	
Front silencer to manifold	45 (apply Optimoly TA to clamp seat)	
Front silencer to main-stand link	20	
Silencer to rear frame at top	35	
Oxygen sensor to silencer	45 (apply Optimoly TA to thread)	
End cap to rear silencer	8 (threads greased)	
Bracket to rear silencer	15 (threads greased)	
21 Clutch		
Clutch housing	Closing torque Wrench angle	40 (oil screw threads lightly) 32°
Housing cover to housing	12	
Clutch line to handlebar fitting	14	
Slave cylinder to gearbox	9	
Grub screw in filler adapter	10	

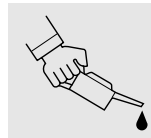



Model	R 1150 GS	
Connection	Nm	
23 Transmission		
Oil drain plug		30
Oil filler plug		30
Gearbox to engine block		22
Shift lever to footrest plate		35
Selector lever to selector shaft		9
Housing cover to housing		9
Frame tube to gearbox		
1. to gearbox and left footrest plate		42 (clean thread + Loctite 243)
2. clamp block, frame tube to gearbox		9
3. to gearbox and right footrest plate		42 (clean thread + Loctite 243)
31 Front forks		
Quick-release axle clamp screws		22
Fastener, fixed tube and fork bridge		45 (free from oil and grease)
Slider tube bridge to slider tube		25 (clean thread + Loctite 243)
Threaded stud to frame		130 (clean thread + Loctite 243)
Ball joint to fork slider bridge		230 (apply light coat of Never Seeze to thread)
Leading link to ball joint		130 (clean thread + Loctite 2701)
Leading link to engine	right	73
Screw cap to leading link	left	42 (apply light coat of Never Seeze to thread)
Suspension strut to front frame		43
Spring strut to leading link		50
32 Steering		
Handlebar to fork bridge		21
Handlebar weight to handlebar		21
Pivot screw, handlebar lever		11 (Tuflok Blue thread-locking compound; screw can be released and tightened a number of times)

Model	R 1150 GS
Connection	Nm
33 Rear wheel drive	
Oil filler plug	23
Oil drain plug	23
Threaded ring	160 (clean thread + Loctite 577)
Hexagon nut, input bevel gear	200 (clean thread + Loctite 2701)
Cover to rear-wheel drive housing	35
Fixed bearing stud, swinging arm to gearbox/rear axle housing	160 (clean thread + Loctite 2701)
Floating bearing stud, swinging arm to gearbox/rear axle housing	7 (clean thread + Loctite 2701)
Locknut of floating bearing stud bolt	160
Reaction link to rear wheel drive	43 (load approx. 85 kg (187 lbs) onto motorcycle and tighten loose reaction link)
Reaction link to gearbox	40 (load approx. 85 kg (187 lbs) onto motorcycle and tighten loose reaction link)
Spring strut to rear frame	50
Spring strut to rear swinging arm	58 (clean thread + Loctite 243)
Hydraulic spring preload adjuster to footrest plate	22
34 Brakes	
Brake caliper to fork slider tube	40
Brake caliper to rear wheel drive	40
Brake disc to front wheel	24 (clean thread + Loctite 243)
Brake disc to rear wheel drive	21 (clean thread + Loctite 243)
Master cylinder to footrest assembly	9
Footbrake lever to footrest assembly	21
Footbrake-lever stop	9
Brake lines/brake hose to brake components	18
Brake hose to bracket	9
Brake hose to brake lever fitting	18
Hose bracket to helmet lock	9
Bracket to front frame	9
Bracket to rear frame	9 (clean thread + Loctite 2701)
Bracket to fork bridge	5 (clean thread + Loctite 2701)
ABS sensor	4 (handtight)

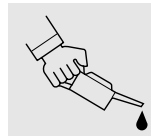



Model	R 1150 GS
Connection	Nm
34 Brakes	
Front brake caliper bleed screw	14
Rear brake caliper bleed screw	6
Pressure modulator bleed screw	14
Filler adapter in brake caliper	18 (clean thread + Loctite 243 or new filler adapter)
Grub screw in filler adapter	10
ABS unit to holder M 6 screw	8 (clean thread + Loctite 243)
36 Wheels and tyres	
Quick-release axle clamp screws	22
Quick-release axle threaded fastener	30
Rear wheel to rear-wheel drive Hand-tighten wheel studs, then tighten in diagonally opposite sequence	
Initial tightening	72
Final tightening	105
Sensor ring to front/rear wheel	4 (hand tight, clean threads + Loctite 2701)
Spoke nipple	3.5 + 2
Grub screw	1.1
46 Frame	
Frame to engine	82
Struts to frame	58
Struts to engine	58 (clean thread + Loctite 2701)
Rear frame to gearbox/engine to gearbox and footrest plate to engine	42 (clean thread + Loctite 243) 42
Carrier plate for main stand to engine, right M 12 screw	72 (clean thread + Loctite 2701)
Pivot mount to engine, left M 12 screw M 8 screw	72 (clean thread + Loctite 2701) 21
Pivot mount of main (centre) stand (stud bolt)	21 (clean thread + Loctite 243)
Pivot mount of main (centre) stand (machine screw)	21
Side stand to pivot mount	58 (clean thread + Loctite 2701)

Model	R 1150 GS
Connection	Nm
46 Frame	
Footrest plate to gearbox/ Rear footrest plate to rear frame M 8 screws	21
Fairing bracket to front frame	21
Front carrier to fairing bracket	8
Mudguard at bottom to slider tube	4 (clean thread + Loctite 2701)
Mudguard at bottom to slider tube bridge	5 (clean thread + Loctite 2701)
51 Equipment	
Mirrors	10
Ignition/steering lock to fork bridge	20 (micro-encapsulated)
61 General electrical equipment	
Horn to holder	10 (clean thread + Loctite 243)
Ground (earth) strap to engine block	9

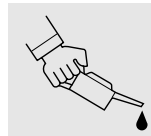

Table of operating fluids



Item	Use	Order number	Quantity
Lubricant			
Staburags NBU 30 PTM	High-performance lubricating paste	07 55 9 056 992	75 g tube
Optimoly MP 3	High-performance lubricating paste	07 55 9 062 476	100 g tube
Optimoly TA	High-temperature assembly paste	18 21 9 062 599	100 g tube
Silicone grease 300, heavy	Damping grease	07 58 9 058 193	10 g tube
Retinax EP2	Wheel, steering head and taper roller bearing grease	83 22 9 407 845	100 g tube
Contact spray	Contact spray	81 22 9 400 208	300 ml spray
Chain spray	Drive chain	72 60 2 316 676 72 60 2 316 667	50 ml spray 300 ml spray
Sealants			
3-Bond 1110 B	Surface sealant	07 58 9 056 998	5 g tube
3-Bond 1209	Surface sealant	07 58 9 062 376	30 g tube
OMNI VISC 1002	Surface sealant	07 58 1 465 170	90 g tube
Loctite 574	Surface sealant	81 22 9 407 301	50 ml tube
Loctite 577	Thread locking compounds	07 58 2 328 736	5 g tube
Curil K 2	Heat-conductive sealant	81 22 9 400 243	250 g can
Adhesives and retaining agents			
Loctite 648	Joint adhesive (low clearance)	07 58 9 067 732	5 g bottle
Loctite 638	Joint adhesive (greater clearance)	07 58 9 056 030	10 ml bottle
Loctite 243	Thread retainer, medium-strength	07 58 9 056 031	10 ml bottle
Loctite 270	Thread retainer, strong	81 22 9 400 086	10 ml bottle
Loctite 2701	Thread retainer, strong	33 17 2 331 095	10 ml bottle
Loctite 454	Cyanacrylate adhesive (gel)	07 58 9 062 157	20 g tube
Cleaners			
Brake cleaner	Brake cleaner	83 11 9 407 848	600 ml spray
Metal Polish	Polish for chrome-plated parts	82 14 9 400 890	100 g tube
Testing agents			
Penetrant MR 68	Crack testing agent for aluminum housings	83 19 9 407 855	500 ml spray
Developer MR 70	Crack testing agent for aluminum housings	81 22 9 407 495	500 ml spray
Installation aids			
BMW cooling spray	Cooling spray	83 19 9 407 762	300 ml spray

Pre-delivery check

General view of crated motorcycle

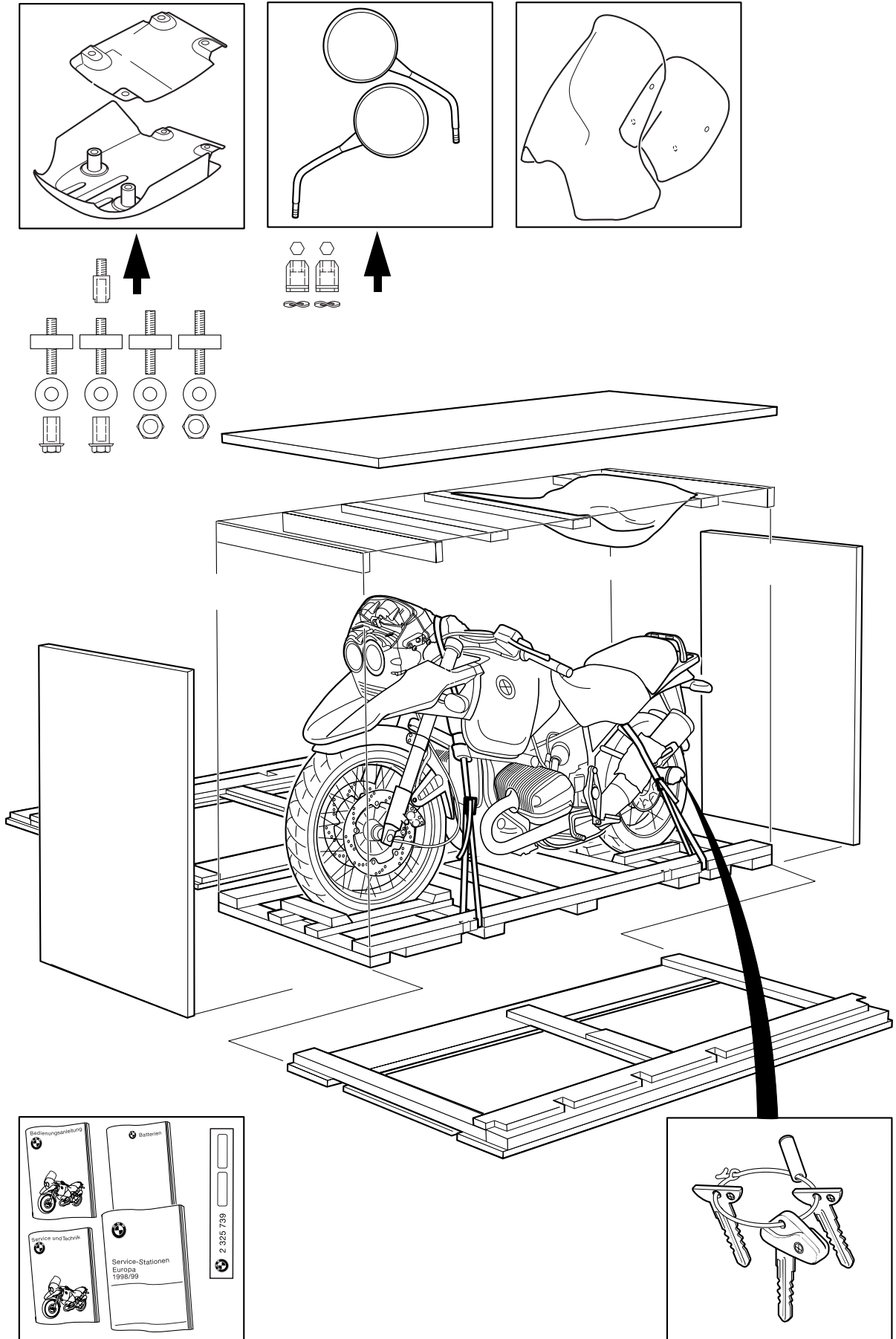

Check the shipping crate for damage

- When the motorcycle arrives, check the packing material immediately for damage and, if necessary, examine the contents for consequential damage.



In case of damage in Germany

- Note the damage on the delivery slip.
- Read the information sheet on damage in transit.
- Notify the supplier without delay (e.g. freight company or DB) and also Bavaria Wirtschaftsagentur GmbH
Abteilung ZW - 12
D-80788 München
Tel. 089/14327-632
Fax. 089/14327-709

In case of damage in importer markets

- Note the damage on the delivery slip.
- Comply with specific national market procedures.
In case of doubt, please submit enquiries to:
Bavaria Wirtschaftsagentur GmbH
Abteilung ZW - 12
D-80788 München
Tel. +49 (0)89 14327-632
Fax. +49 (0)89/14327-709
- Notify the supplier (e.g. freight company) without delay.

Unpacking the motorcycle

- Lever off the cover.
- Take out the separate pack of items:
 - Documentation
 - Windscreen
 - Sump guard with fasteners
- Force off cross-struts with a suitable lever.



Caution:

Do not knock the cross-struts out or the motorcycle may be damaged.

- Remove the end-walls.
- Remove the side-walls.



Caution:

Remove any nails projecting from the base of the packing or lying on the base or on the floor.

- Loosen the front tensioning straps.
- Release the handlebar and resecure in correct position (punch marks aligned).



Caution:

Do not push the motorcycle until the handlebar has been secured in the correct position.



Tightening torque:

Handlebar to fork bridge 21 Nm

- Loosen the rear tensioning straps.
- Push the motorcycle forwards off the pallet.
- Remove the set of keys from the left rear footrest.
- Dispose of the packing materials in an environmentally responsible manner as described in Service Information 23/91 - Sales - .

Inspecting motorcycle for damage

- Check for defects.
- Use the “express handling service” to notify BMW Motorrad, UX-VS-1
Fax: +49 (0)89 382 33220
- Rectify the fault.
- If parts are needed, order them through the usual channel.
- Costs are to be processed by the warranty claim system (stage 4). Defect codes:
 - Parts missing 10 01 00 00 00
 - Parts damaged 10 02 00 00 00
 - Incorrect parts delivered 10 03 00 00 00

Checking that delivery is complete

- All optional extras
- Toolkit
- Documentation



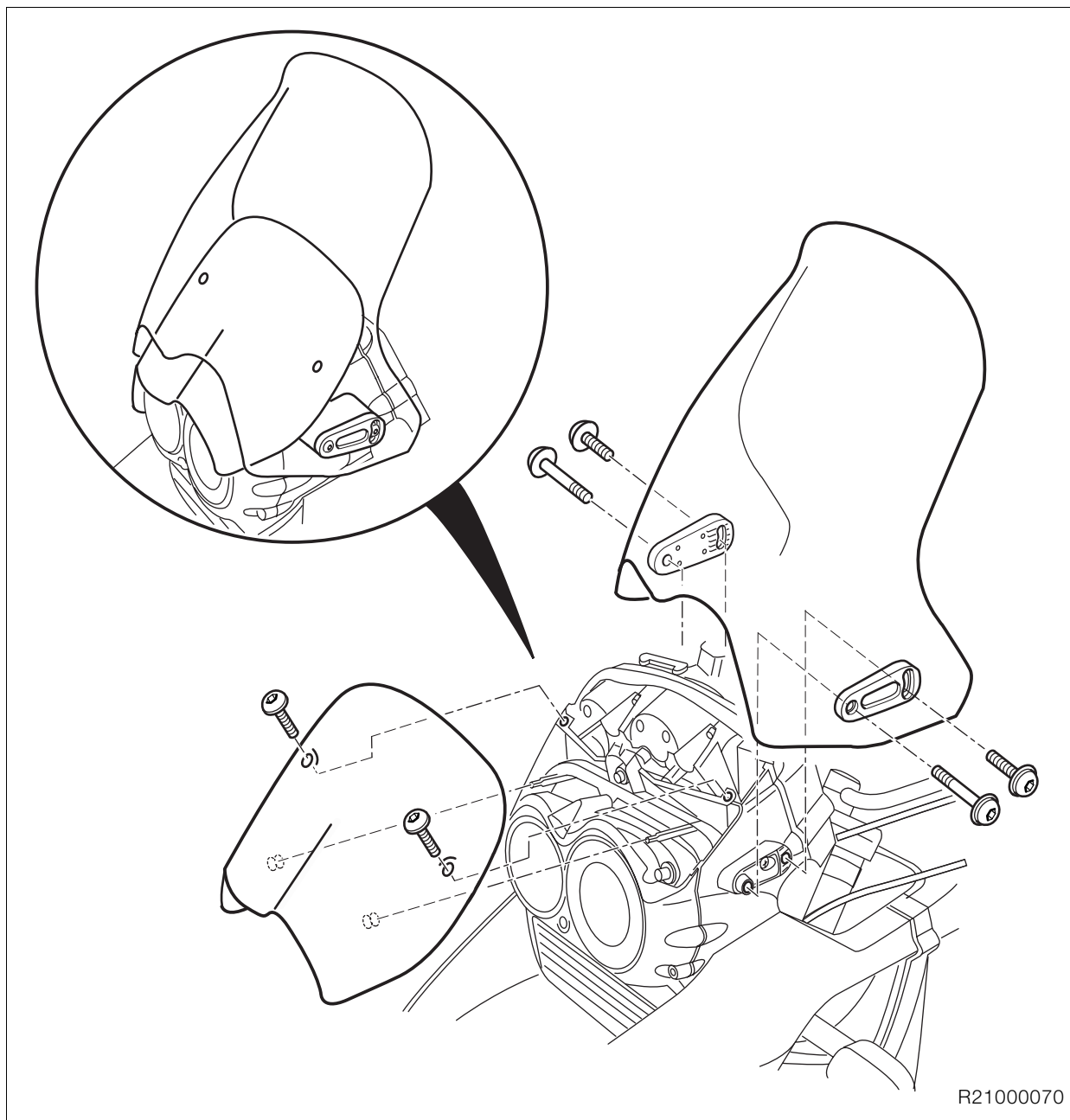

R21000070

Installing remaining items on motorcycle

Install the windscreen

- Carefully tighten the securing screws by hand.

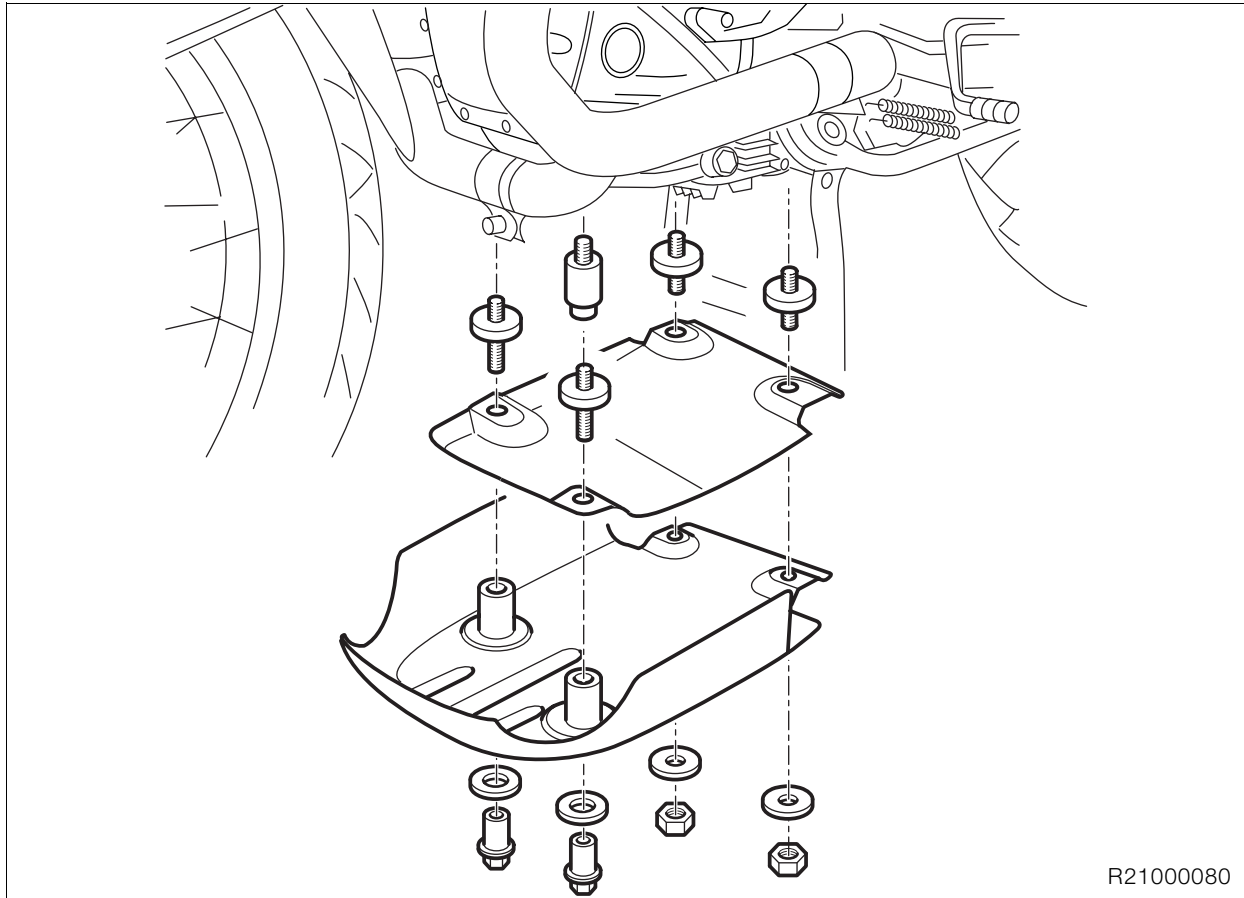

R21000080

Installing sump guard

- Install the spacer bushing at the front left.



! Tightening torque:

Bushing to engine block..... 20 Nm

- Install the front rubber mounts with the long thread down.
- Install the rear rubber mounts.
- Install the inner plate with the outer guard.

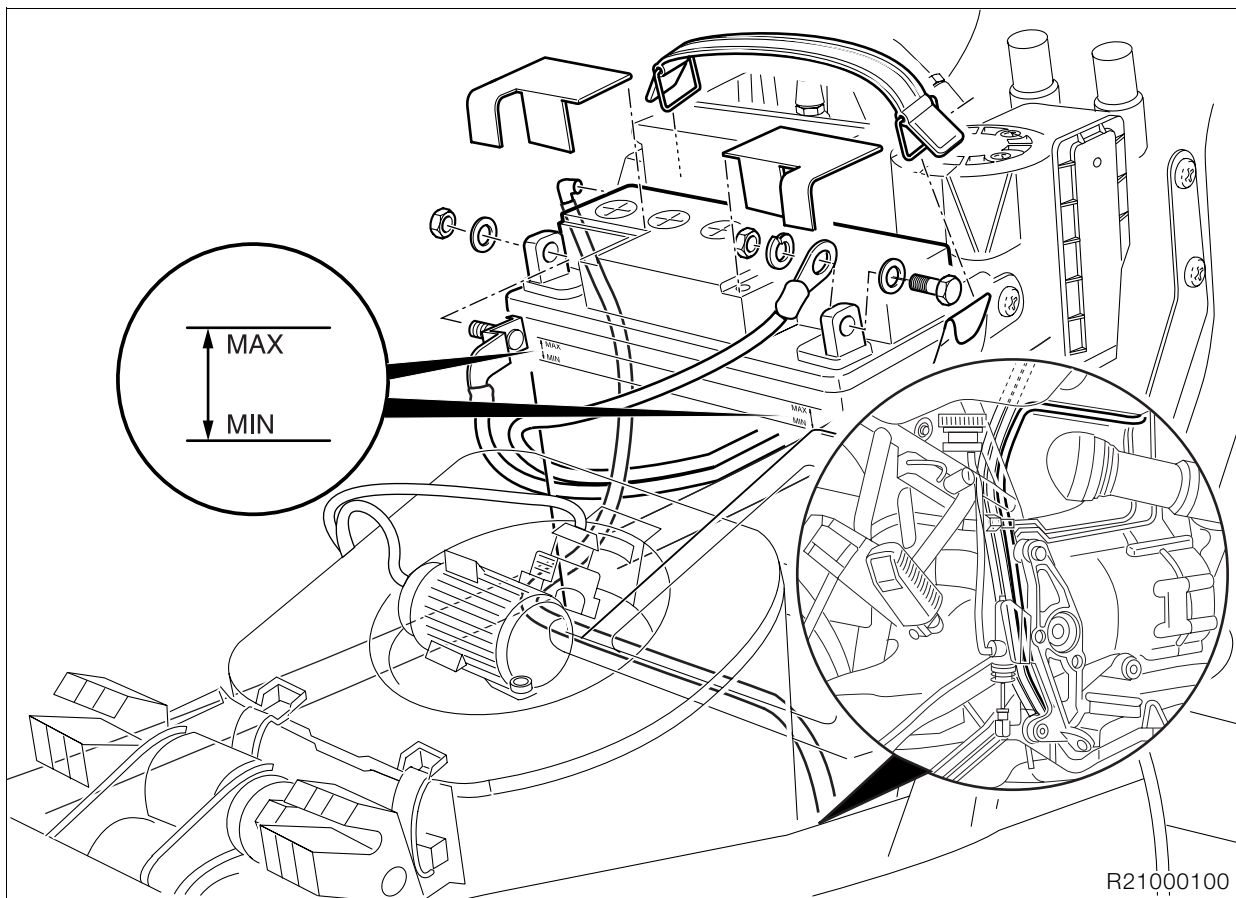

Filling and charging the battery

Disengaging and raising the fuel tank

- Remove seat.
- Remove right side trim.

Caution:

Fuel is flammable and a hazard to health. Observe relevant safety regulations.

- Remove the fastener securing the fuel tank at the rear right.
- Raise the rear of the fuel tank and prop it in this position on a wooden block or similar.

Filling and charging the battery

Warning:

Battery acid is highly caustic. Protect your eyes, face, hands, clothing and the paintwork.

- Disengage the rubber strap holding the battery.
- Disconnect the battery breather hose.
- Remove the battery.
- Fill all the cells with pure battery acid of density 1.28 to the upper mark.
- Allow the battery to stand for approximately 30 minutes.
- The battery does not achieve full charge capacity from being filled, so it has to be charged with a battery charger.

Note:

Follow the instructions for use supplied with the battery charger.

Charge current (amps)

..... 10 % of rated battery capacity (Ah)

Charging time

..... 5-10 hours

- Battery charge can be measured by checking the density of the battery acid.

Acid density

Battery fully charged 1.26-1.30 at 20 °C (68 °F)

- Shake the battery slightly to allow the gas bubbles to escape.
- Wait until the battery acid has settled, check that no more bubbles rise and if necessary, top up the acid to the max. mark.
- Reinstall the plugs.
- Make a note of the charging date on the battery.

Caution:

Connect the positive battery terminal first, then the negative terminal.

- Install the battery.
- Apply acid-proof grease to the battery terminal posts.
- Connect the battery breather line.
- Secure the fuel tank in position.
- Install the right side trim panel.
- Install the seat.

- Switch on the ignition.
- Without starting the engine, fully open the throttle once or twice so that the Motronic control unit can register the throttle-valve positions.



Note:

Disconnecting the battery deletes all entries (e.g. faults, settings) stored in the Motronic control unit's memory. Loss of settings can temporarily impair the operating characteristics when the engine is restarted.



Tightening torque:

Fuel tank to frame 21 Nm

Checking engine oil when engine is cold, topping up if necessary

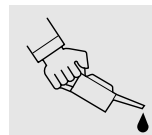
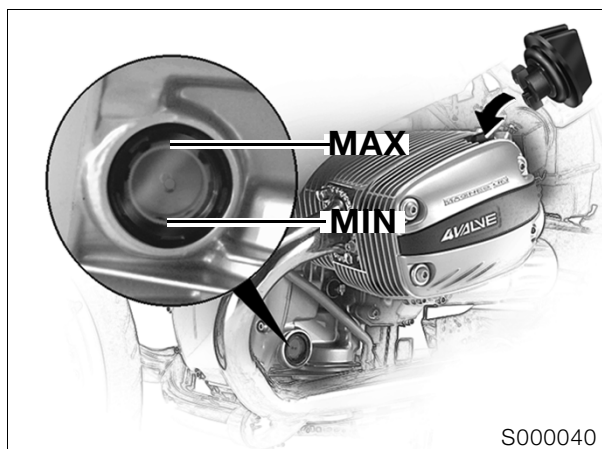

- Check oil level with the motorcycle upright.



Caution:

Never top up the engine-oil level past the "MAX" mark.

Required level:..... MAX

Checking headlight beam angle, adjusting if necessary

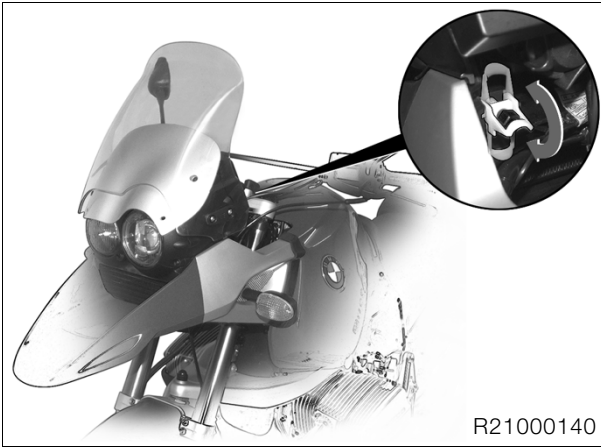

R21000140

- Motorcycle on level surface.
- Rider's weight on motorcycle (approx. 85 kg/176 lbs).
- Move swivel lever to horizontal position (basic setting).
- Turn the adjusting screws to correct the headlight beam throw.

Lateral adjustment:

..... Adjusting screw on left of headlight

Vertical adjustment:

..... Adjusting screw on right of headlight

Turn screw anti-clockwise: longer throw

Turn screw clockwise: shorter throw

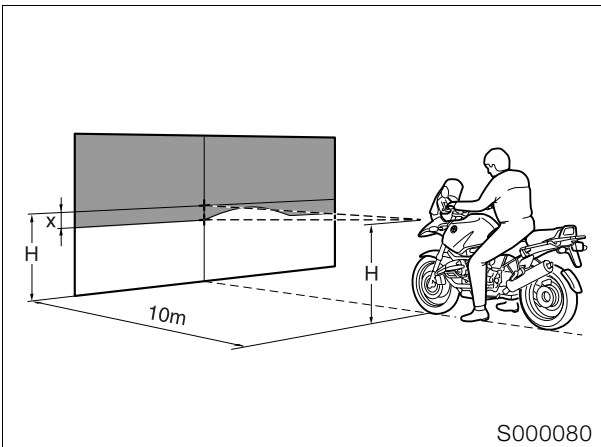

S000080

Setting for headlight beam angle adjuster

..... -15 cm (- 5.9 in)

..... over a distance of 10 m (32.8 ft)

Checking tightness of rear wheel studs



Tightening torque:

Rear wheel studs 105 Nm

Checking tyre pressures

- Check/correct tyre pressures.

Tyre pressures:

Solo front 2.2 bar (31.3 psi)
 rear 2.5 bar (35.6 psi)

Two-up front 2.5 bar (35.6 psi)
 rear 2.7 bar (38.4 psi)

Two-up + luggage front 2.5 bar (35.6 psi)
 rear 2.9 bar (41.2 psi)

Attaching adhesive label

- Remove the adhesive label from the package and fix it in position at the bottom of the glass cover of the rev. counter.

Final inspection and function check

- Clutch
- Check gear shift action.
- Handbrake and foot brake
- Check lights and signalling equipment:
 - Front and rear parking lights
 - Instrument lighting
 - Low and high headlight beams, headlight flasher
 - Brake light (operate brake at front and rear)
 - Turn signals left/right
 - Hazard warning flashers
 - Horn
 - Telltale and warning lights
 - Instruments
- Where necessary, check function of optional extras:
 - ABS: perform starting test. When a speed of 5 km/h (app. 3 mile/h) is reached, both ABS warning lights must go out.
- If necessary, take the motorcycle for a test ride.
- Confirm pre-delivery check in Service and Technical Booklet.
- See “Checking motorcycle for damage” if defects are found.

Final cleaning

- Clean the motorcycle.



Note:

Do not use a steam or high-pressure water jet. The high steam or water pressure could damage seals, the hydraulic system or electrical components.

Handing over the motorcycle

This is the ideal opportunity to familiarise the customer with the motorcycle in order to ensure the customer's satisfaction and safety.

- The following points must be demonstrated and explained to the customer:
 - documentation and stowage space
 - toolkit and stowage space
 - suspension preload adjustment to suit total weight
 - checking brake fluid/clutch operating fluid
 - provision for adjusting handlebar lever positions
 - how to adjust the mirrors
 - controls
 - instruments and telltale lights
 - optional equipment and accessories fitted
 - noise during the regular ABS self-diagnosis procedure
- The user must be given the following information:
 - running-in recommendations and inspection intervals
 - safety check
 - the clutch fluid level rises gradually as the motorcycle is ridden (clutch lining wear)
 - before checking the engine oil level, the engine must be switched off for at least 10 minutes and the motorcycle must be standing on a flat, level surface



Maintenance

Key to maintenance intervals

- BMW Inspection at 1,000 km (600 miles) **I**
- BMW Service every 10,000 km (6,000 miles) **II**
- BMW Inspection, every 20,000 km (12,000 miles) **III**
- BMW Annual Service **IV**



Reading out MoDiTeC fault memory

(Inspections I, II, III and IV)

- Remove the seat.
- Connect the **BMW** MoDiTeC to the diagnosis connector.
- Read out the fault memory.
- Perform all requisite repair work.

Changing engine oil, replacing oil filter element

(Inspections I, II, III and IV)



Note:

If the motorcycle is ridden only for short distances or outside temperatures are below 0°C (32°F) change the oil and replace the oil filter element every 3 months, or not later than every 3,000 km (1,800 miles).

- Change the oil at operating temperature.

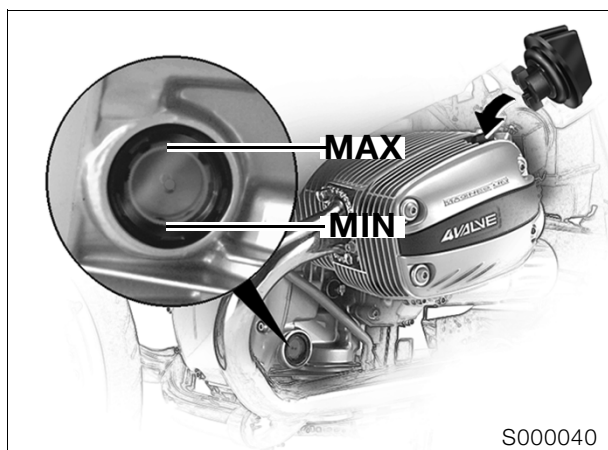

- Remove screw plug.

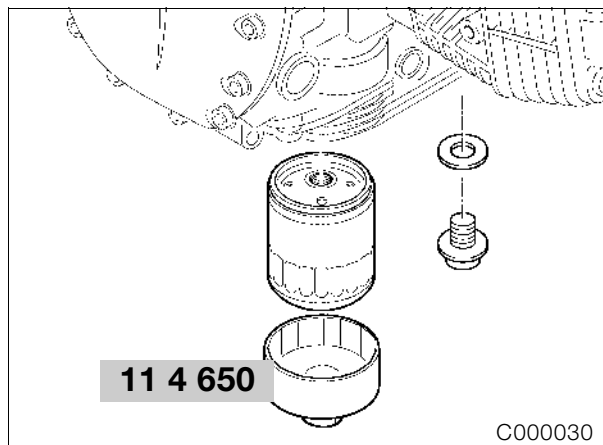

- Remove oil drain plug and drain off oil.
- Reinstall the oil drain plug with a new sealing ring.
- Use oil filter wrench, **BMW No. 11 4 650**, to remove the oil filter.
- Coat sealing ring on new oil filter element with oil and install filter.
- Refill with oil to correct level.
- Install the screw plug.



Caution:

Never top up the engine-oil level past the "MAX" mark.



Tightening torque:

Oil filter.....	11 Nm
Oil drain plug.....	32 Nm

Engine oil quantities:

With oil filter change	3.75 l (6.6 Imp. pints/3.96 US quarts)
Without oil filter change.....	3.50 l (6.2 Imp. pints/3.69 US quarts)
Quantity of oil between MIN and MAX marks	0.50 l (0.88 Imp. pint/0.52 US quart)

Engine oil grade:

Brand-name HD oil for spark-ignition engines, API classifications SF, SG, SH; combination with CD or CE specification.
Brand-name HD oil of CCMC classification G4, G5; amendment PD2 is permissible.

Changing oil in gearbox

(Inspections III and IV)
or at the latest every 2 years

- Change the gearbox oil at operating temperature.

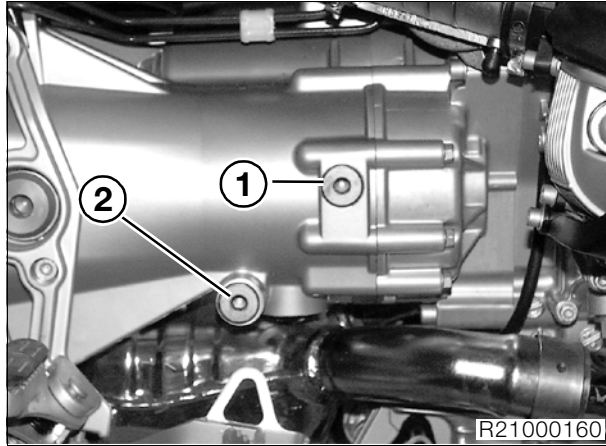

- Remove oil filler plug (1).
- Remove oil drain plug (2) and allow the oil to drain out.
- Reinstall the oil drain plug with a new sealing ring.
- Fill with gearbox oil.
- Insert oil filler plug with new seal.

 **Tightening torque:**

Oil drain plug 30 Nm
Oil filler plug 30 Nm

Quantity:

Initial filling/oil changes approx. 1.0 l
(1.76 Imp. pints/1.06 US quarts)

Oil grade for gearbox:

Brand-name hypoid gear oil, SAE 90, API class GL 5

Changing the oil in the rear wheel drive

(Inspections I, III and IV)
Every 40,000 km (24,000 miles) or at the latest
every 2 years

- Change the gearbox oil at operating temperature.

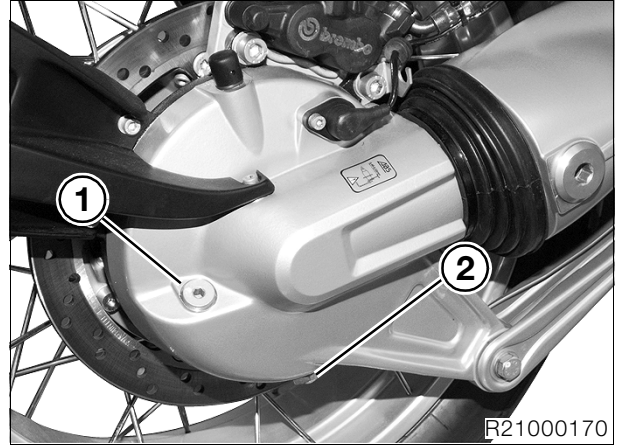

- Remove oil filler plug (1).
- Remove oil drain plug (2) and allow the oil to drain out.
- Reinstall the oil drain plug with a new sealing ring.
- Fill with gearbox oil.
- Insert oil filler plug with new seal.

 **Tightening torque:**

Oil drain plug 23 Nm
Oil filler plug 23 Nm

Quantity:

to the lower edge of the filler opening
..... approx. 0.25 l (0.44 Imp. pint/0.26 US quart)

Oil grade for rear wheel drive:

Brand-name hypoid gear oil, SAE 90, API class GL 5



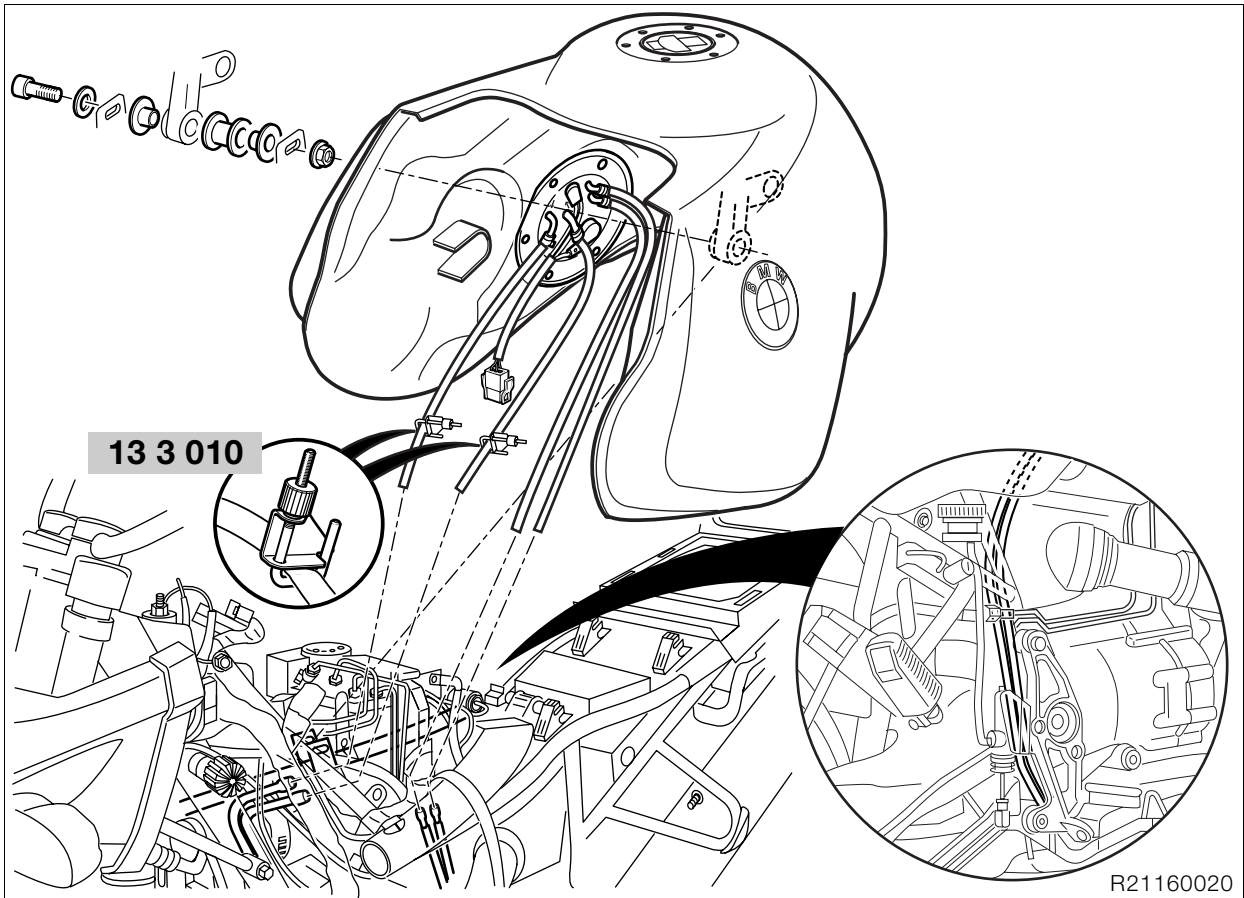

R21160020

Replacing fuel filter

(Inspection III)

In normal operating conditions every 40,000 km (24,000 miles); if fuel quality is poor every 20,000 km (12,000 miles)

- Remove the seat.
- Remove right trim panel.
- Disengage fuel tank.



Caution:

Fuel is flammable and a hazard to health. Observe relevant safety regulations.

- Seal the fuel feed and return lines with hose clips, **BMW No. 13 3 010**, and disconnect.
- Disconnect breather lines.
- Pull the plug connector off the fuel pump unit.
- Remove fuel tank.

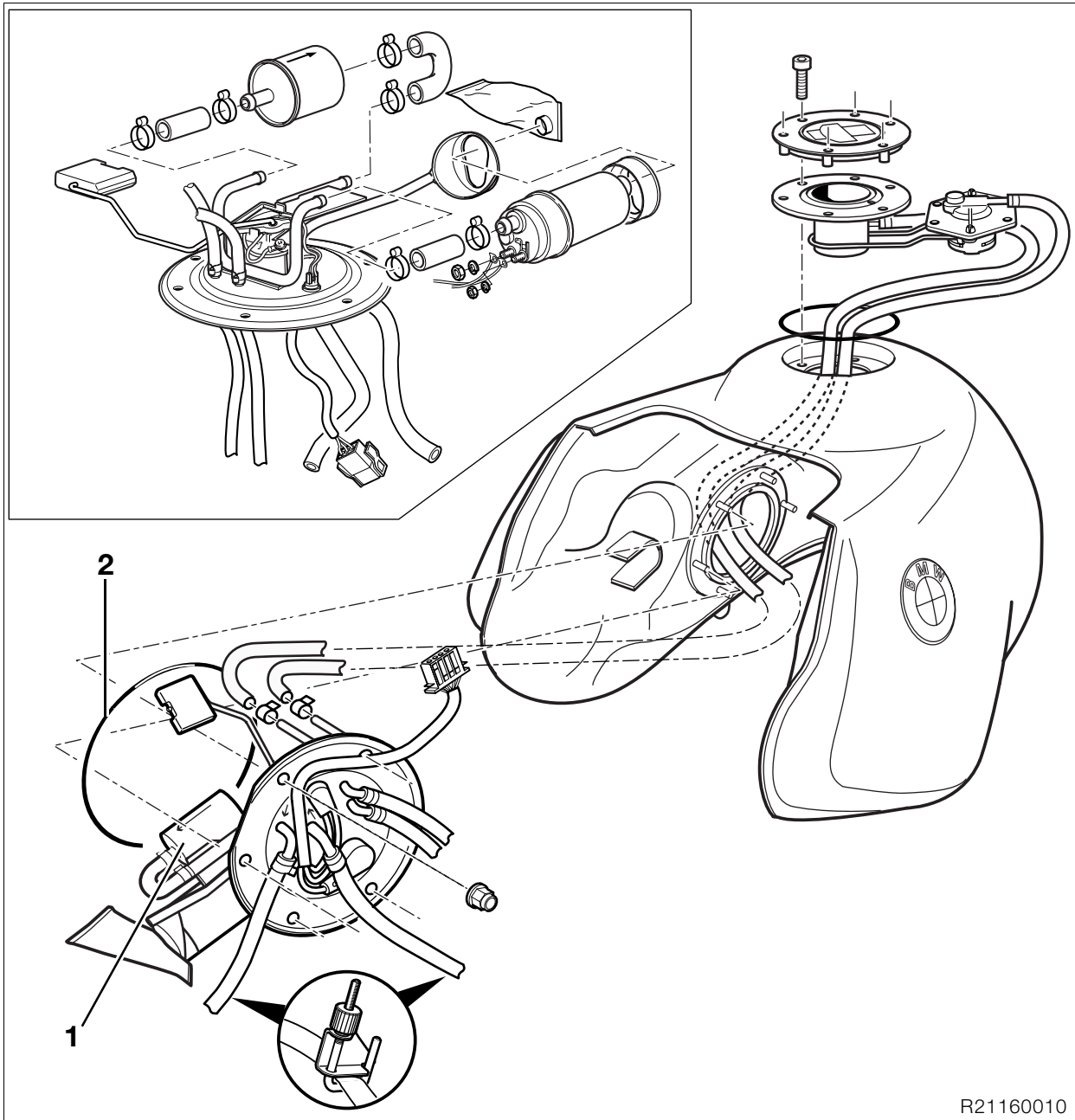

R21160010

- Drain fuel tank.
- Remove fuel pump unit.
- Disconnect hoses from fuel filter (1).
- Replace the fuel filter.

⚠ Caution:
Note correct direction of flow through fuel filter.

- Secure non-reusable hose clips with pliers, **BMW No. 13 1 500**.

⚠ Caution:
Make sure O-ring (2) is in perfect condition.

🔧 Tightening torque:
Fuel pump unit 6 Nm

⚠ Caution:
After installing, check fuel pump unit for leaks.

📄 Note:
Make sure that breather lines are correctly routed.

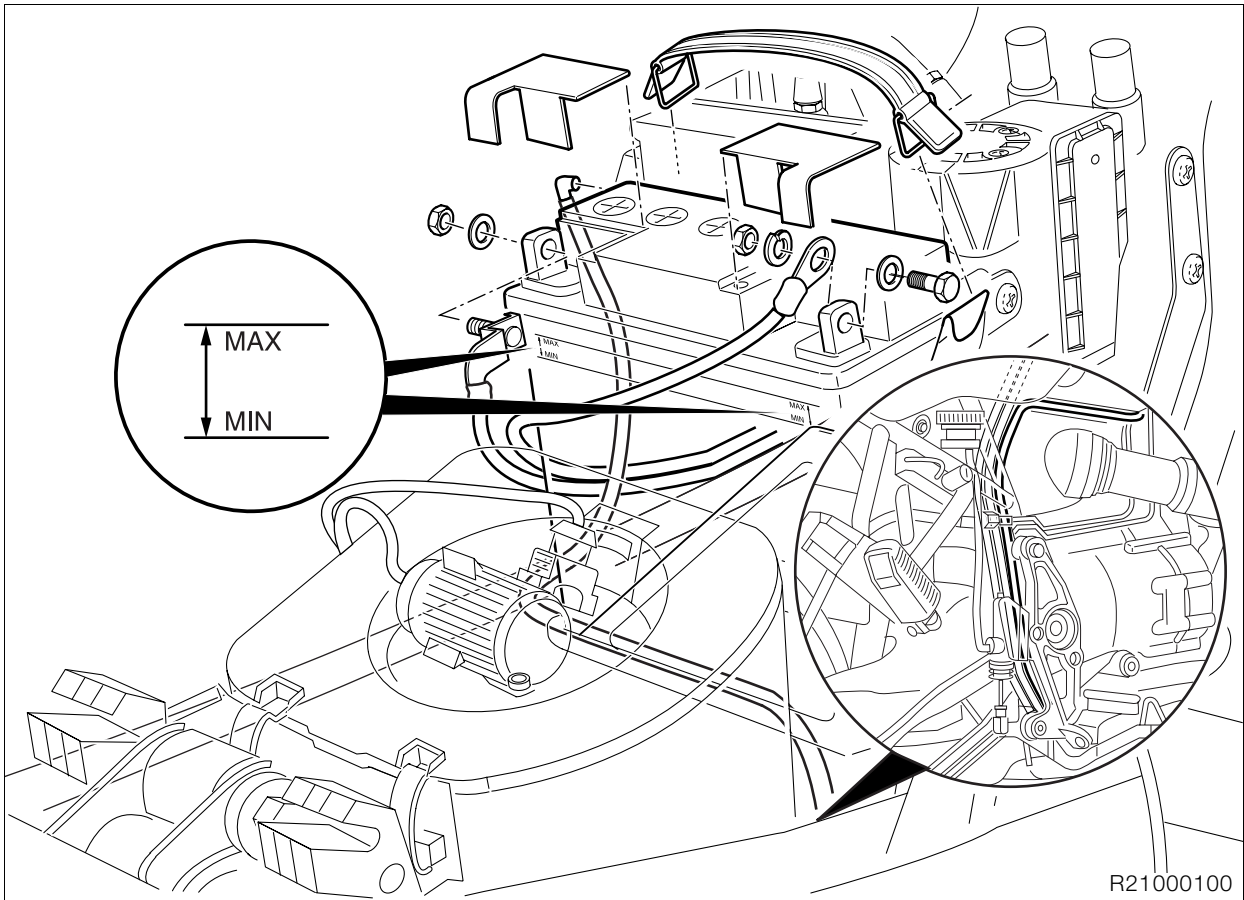

Checking battery fluid level and topping up if necessary; cleaning and greasing the battery posts

(Inspections III and IV)

- If necessary, disengage fuel tank and lift at rear.
- Disengage the rubber strap holding the battery.
- Check the battery fluid level.
- Top up the acid level to the "MAX" mark with distilled water.
- Grease the battery posts.

Acid proof battery-post grease:

.....e.g. Bosch Ft 40 V1

Replacing intake air filter element

(Inspection III)

In very dirty and dusty operating conditions, replace every 10,000 km (6,000 miles) or even more frequently if necessary

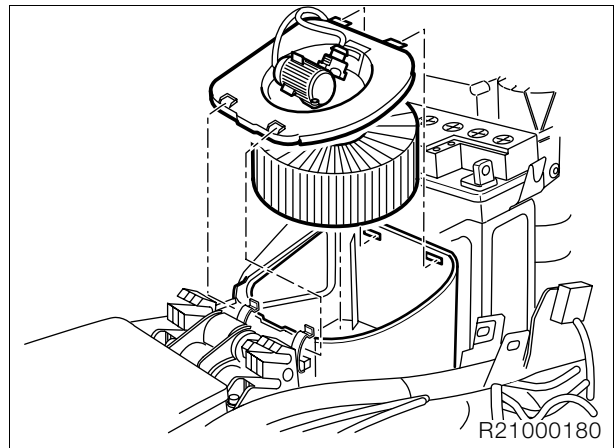

- Open clips securing air filter cover.
- Replace air filter element.
- Close air filter cover.
- Install the fuel tank.
- Make sure that breather lines are correctly routed.

⚠ Tightening torque:

Fuel tank to rear frame 21 Nm

Replacing Poly-V belt

(Inspection III)
(every 60,000 km/36,000 miles)

- If necessary, disengage fuel tank and pull to the rear.

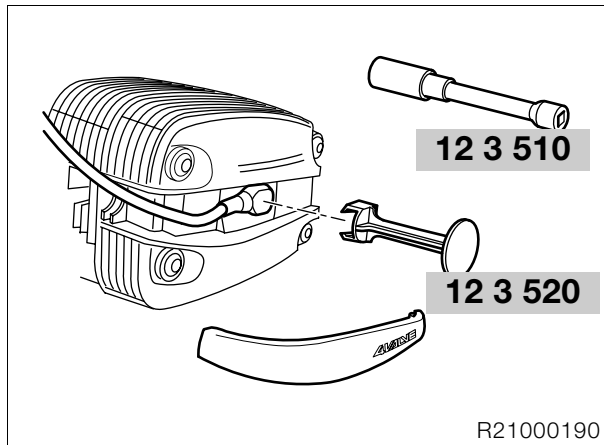

- Remove cover to expose spark plug caps.
- Pull off spark plug caps with special puller, **BMW No. 12 3 520**.
- Remove spark plugs with the spark plug wrench, **BMW No. 12 3 510**.

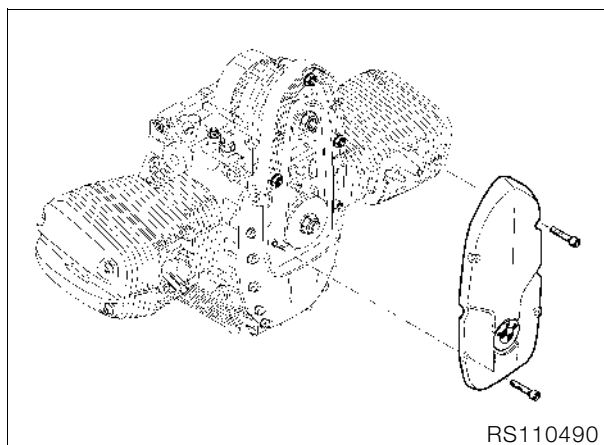

- Remove front cover.

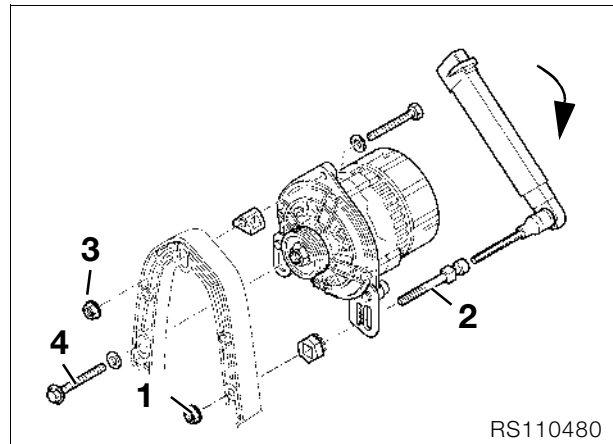

- Slacken alternator mounting screws and nuts (1,3,4) and install a new Poly-V belt if necessary.

Poly-V belt adjusting procedure:

Poly-V belt installation procedure:

- Place the Poly-V belt in position, tension it and turn the engine over once, then relieve belt tension.

Poly-V belt tensioning procedure:

1. Slightly tighten hex nut (1) on adjusting screw (2) by hand (**do not use tools**).
2. Tighten adjusting screw (2) with a torque wrench and keep preload applied.
3. Tighten upper retaining nut (3), then remove torque wrench from adjusting screw.
4. Tighten all screws and nuts.

Tightening torque:

Poly-V belt preload..... 8 Nm
Alternator
to alternator support cover..... 20 Nm

Checking brake system for correct operation and freedom from leaks; repairing/replacing if necessary

(Inspection III)

- Check brake system for leaks.



Checking brake fluid level

(Inspections II and III)



Note:

The volume of the brake fluid (MIN/MAX) is sufficient for lining thicknesses from new to the wear limit. It is not normally necessary to top up the fluid to accommodate lining wear. If the level drops below the MIN mark, this indicates some other fault.

Front brake

- Place the motorcycle on its centre stand.

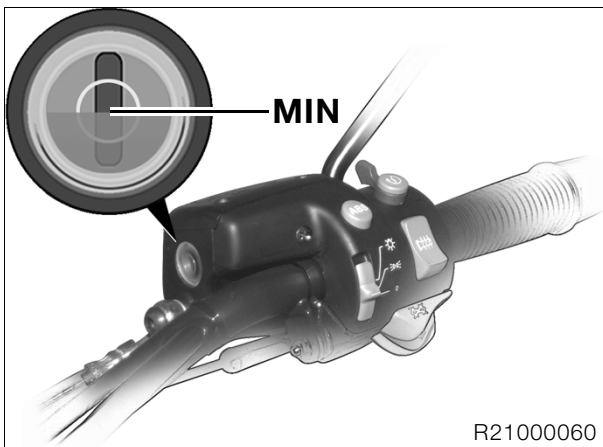

- Turn the handlebars to the right.
- Check that the front wheel is on the ground.

Required level with new brake pads:

(Initial fill quantity)

.. make sure that no bubbles are visible in the sight glass

- Handlebar centred.
- Check that the front wheel is on the ground.

Minimum fluid level

Brake pads worn: not less than
 half way up sight glass

Brake fluid gradeDOT 4

Rear brake

- The motorcycle must be upright.

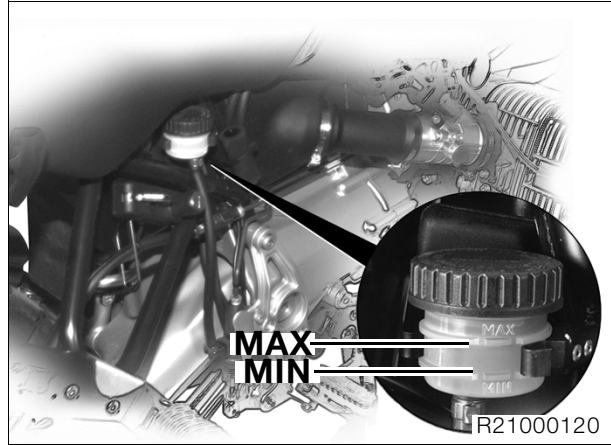

Required level

Brake pads new: MAX
 Brake pads worn: not less than MIN

Brake fluid gradeDOT 4

Checking brake pads and discs for wear/replacing

(Inspections II and III)

Checking front brake pad wear

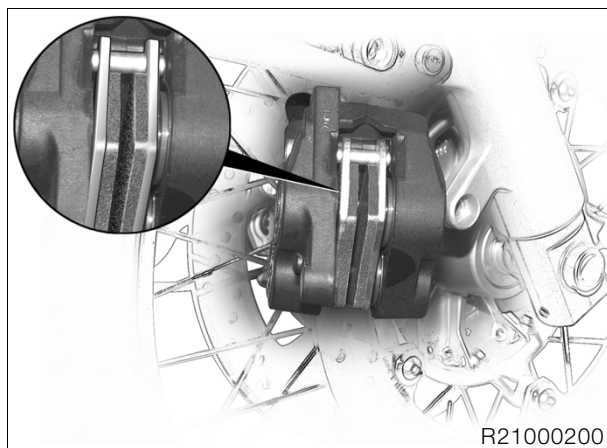

- Check/measure thickness of brake pads.

⚠ Caution:

Brake pad thickness must not fall below the minimum value.
Always replace the brake pads as a complete set.

Minimum pad thickness: 1.0 mm (0.04 in)

Checking rear brake pad wear

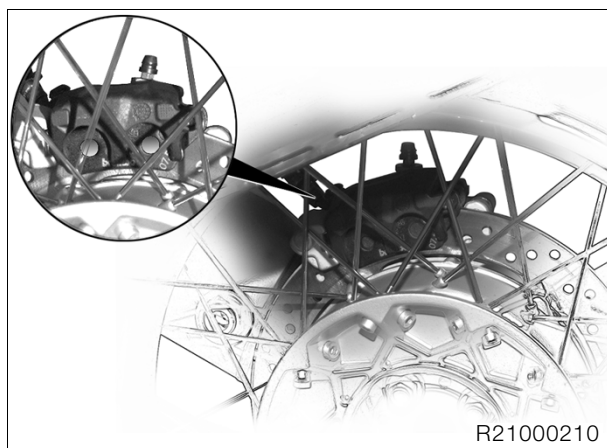

- Make sure that the brake disc is not visible through the bore in the inner brake pad.
- If necessary, check/measure thickness of brake pads.

⚠ Caution:

Brake pad thickness must not fall below the minimum value.
Always replace the brake pads as a complete set.

Minimum pad thickness: 1.5 mm (0.59 in)

Checking brake disc wear

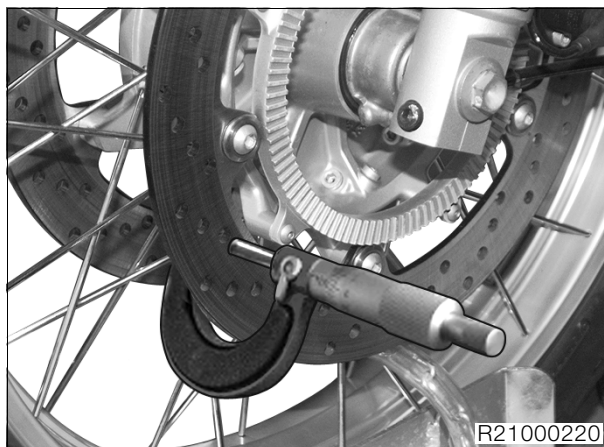

- Examine the brake discs carefully for cracks, damage, distortion, wear and score-marks.

Brake disc wear limit:

front:..... 4.5 mm (0.18 in)
rear:..... 4.5 mm (0.18 in)

Replacing brake pads, front brake

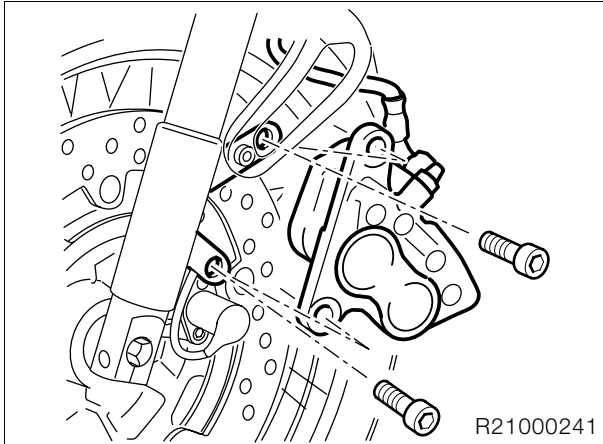

- Remove brake caliper.

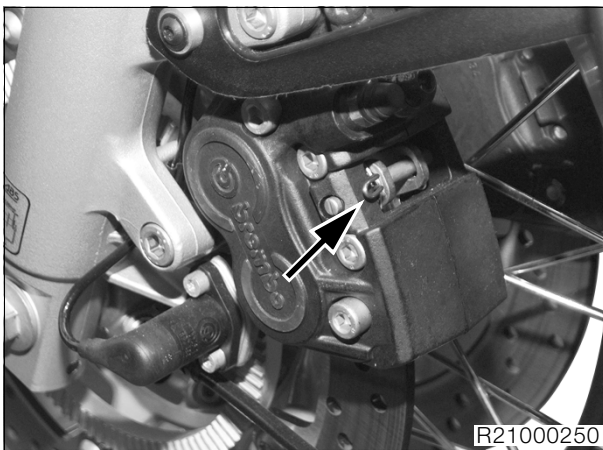

- Remove keeper (arrow) from retaining pin.
- Drive out retaining pin.
- Remove brake pads.
- Installation is the reverse of the removal procedure.
- Before installing the brake caliper, force the pistons fully back with resetting tool,
BMW No. 34 1 500.

 **Tightening torque:**
Brake caliper to fork slider tube..... 40 Nm

Replacing brake pads, rear brake

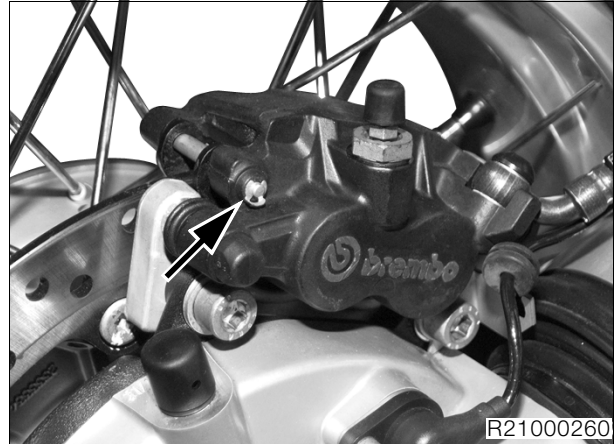

- Remove brake caliper.
- Remove keeper (arrow) from retaining pin.
- Drive the retaining pin out towards the wheel side.
- Remove brake pads.
- Installation is the reverse of the removal procedure.
- Before installing the brake caliper, force the pistons fully back.

 **Tightening torque:**
Brake caliper to rear wheel drive 40 Nm

Changing brake fluid and bleeding brake system

Change the brake fluid annually (Inspection IV)

Bleeding front brake circuit/changing brake fluid



Note:

This description applies to brake filling and bleeding devices with vacuum extraction of the brake fluid at the brake caliper. If other devices are used, comply with their manufacturers' instructions.

- Remove brake calipers.



Caution:

Keep the brake caliper parallel to the brake disc when removing and installing. There is a risk of damage to the brake pads.

- Remove the brake pads.
- Release clamps securing handlebar.
- Turn the front wheel and the handlebar to a position in which the brake fluid reservoir is horizontal.
- Tighten the handlebar and secure the front wheel in this position.
- Remove reservoir cover with rubber diaphragm.



Caution:

Do not allow brake fluid to come into contact with painted parts of the motorcycle as brake fluid destroys paint.

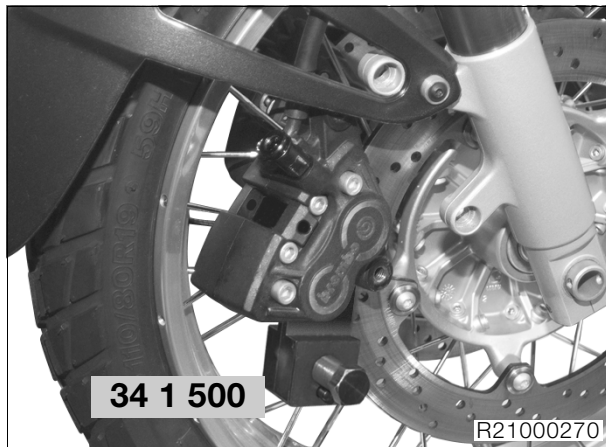

- Use resetting tool, **BMW No. 34 1 500**, to force the pistons of the right-hand brake caliper fully back.
- Take out the resetting tool and insert spacer, **BMW No. 34 1 520**, in its place.
- Use resetting tool, **BMW No. 34 1 500**, to force the pistons of the left-hand brake caliper fully back, and allow the resetting tool to remain in position.

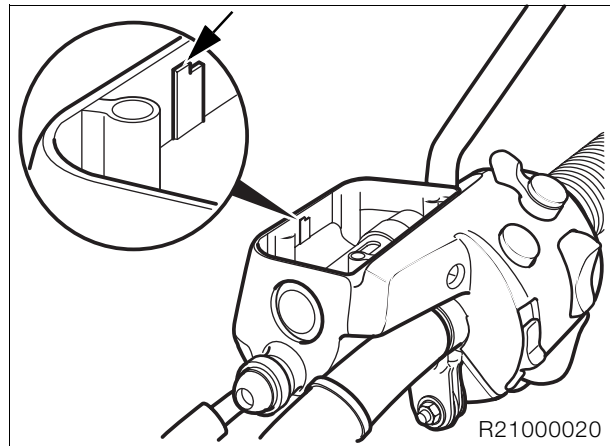

- Top up the brake fluid level to the "MAX" mark (arrow).



Caution:

When adding brake fluid, do not allow it to enter the holes for the reservoir lid screws.

- **[ABS]** Begin by bleeding the pressure modulator.

➔ See **Additional information for [ABS]**

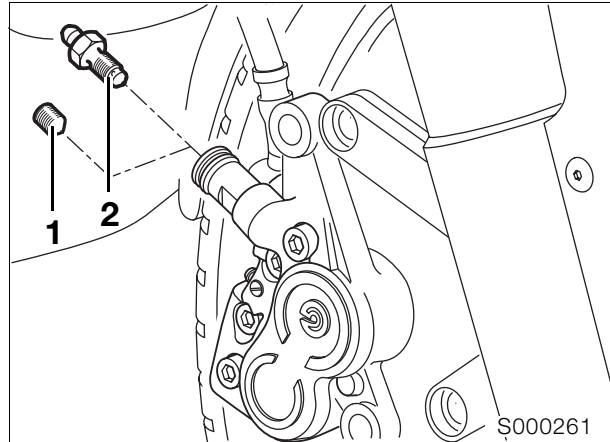

- Wrap a cloth around the filler adapter on the right-hand brake caliper.
- Remove the socket-head grub screw (1) from the filler adapter on the right-hand brake caliper.
- Connect the brake bleeding device to bleed screw (2).
- Screw the bleed screw all the way into the filler adapter (valve in filler adapter closed).
- Open the bleed screw by half a turn (valve open).
- Draw off brake fluid until it emerges clear and free from air bubbles.



Caution:

While bleeding the system, do not allow the brake fluid level to drop below the "MIN" mark, as otherwise air will be drawn into the brake system. Bleed the system again if this happens.

- Remove the bleed screw.
- Disconnect the brake bleeding device from the bleed screw.
- Reinstall socket-head grub screw (1) in the filler adapter.



Caution:

The motorcycle is not permitted on the road without the grub screw in place and secure in the filler adapter.



- Connect the brake bleeding device to the bleed screw of the left-hand brake caliper.
- Open the bleed screw by half a turn.
- Draw off brake fluid until it emerges clear and free from air bubbles.
- Close the bleed screw.
- Assembly is the reverse of the disassembly procedure.
- Top up the brake fluid until the level reaches the "MAX" mark.
- Wipe the rim of the reservoir, the rubber gaiter and the cover to remove brake fluid, and carefully re-assemble the components.
- Resecure the handlebar in the correct position (punch marks aligned).
- Recheck the brake-fluid level.
- Place the motorcycle on its centre stand.

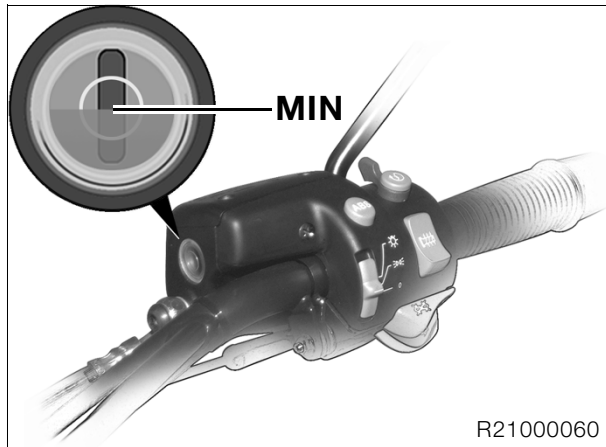

- Turn the handlebar to the right.
- Check that the front wheel is on the ground.

Required level with new brake pads:

(Initial fill quantity)

.. make sure that no bubbles are visible in the sight glass

- Handlebar centred.
- Check that the front wheel is on the ground.

Minimum fluid level

Brake pads worn: not less than
..... half way up sight glass

- Check the function of the brake system.

Brake fluid gradeDOT 4



Tightening torque:

Brake caliper to fork slider tube..... 40 Nm
 Grub screw in filler adapter 10 Nm
 Bleed screw in front brake caliper 14 Nm
 Handlebar to fork bridge 21 Nm

Additional information for [ABS]

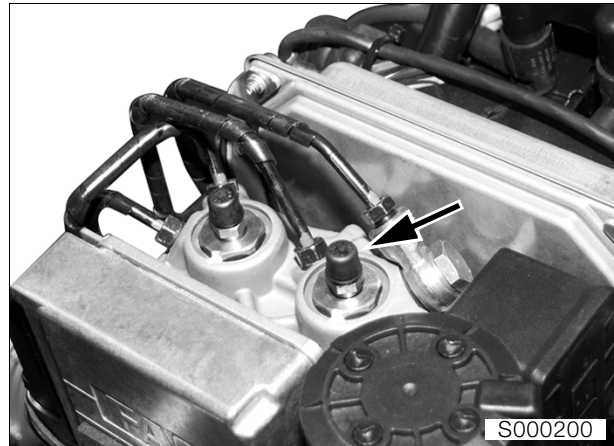

- Before bleeding the brake caliper, connect the brake bleeding device to the bleed screw on the pressure modulator for the front brake (arrow) marked **VR** (mark for rear brake is **HR**).
- Open the bleed screw by half a turn.
- Draw off brake fluid until it emerges clear and free from air bubbles.
- Close the bleed screw.



Tightening torque:

Bleed screw in pressure modulator 14 Nm

Bleeding rear brake circuit/changing brake fluid

- **[ABS]** Begin by bleeding the pressure modulator.
- ➔ See **Additional information for [ABS]**
- Remove reservoir cover.

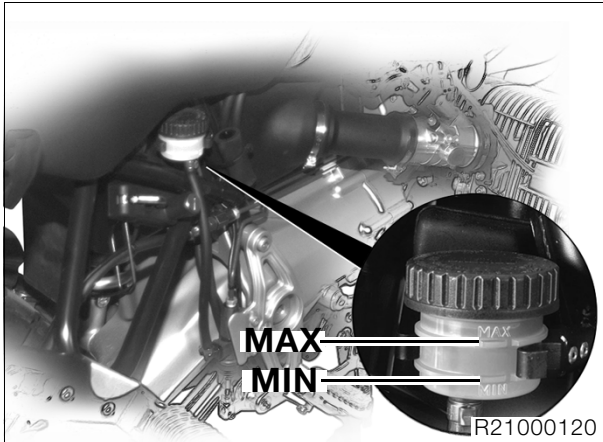

- Top up the brake fluid level to the "MAX" mark.

Caution:

Do not allow brake fluid to come into contact with painted parts of the motorcycle as brake fluid destroys paint.

- Remove the brake caliper.
- Remove the inner brake pad.
- Move the brake caliper to a horizontal position.

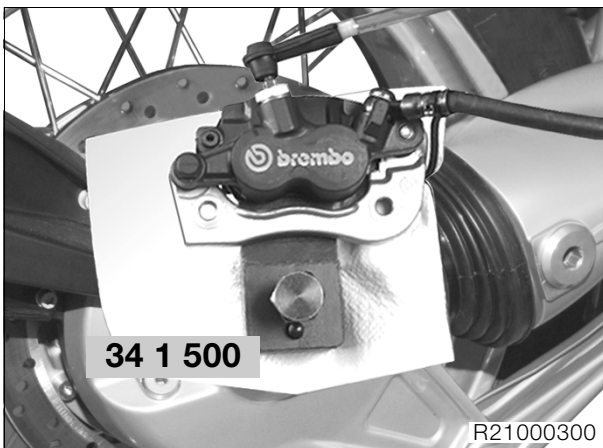

- Using resetting tool, **BMW No. 34 1 500**, force the pistons fully back.
- Connect the brake bleeding device and open the bleed screw.
- Draw off brake fluid until it emerges clear and free from air bubbles.

Caution:

While bleeding the system, do not allow the brake fluid level to drop below the "MIN" mark, as otherwise air will be drawn into the brake system. Bleed the system again if this happens.

- Close the bleed screw.
- Top up the brake fluid until the level reaches the "MAX" mark.
- Assembly is the reverse of the disassembly procedure.

- Check the function of the brake system.

Brake fluid gradeDOT 4

Tightening torque:

Bleed screw in rear brake caliper 6 Nm
 Brake caliper to rear wheel drive 40 Nm

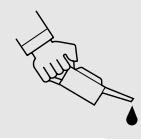

Checking clutch operating fluid level

(Inspections II and III)

- Place the motorcycle on its centre stand.

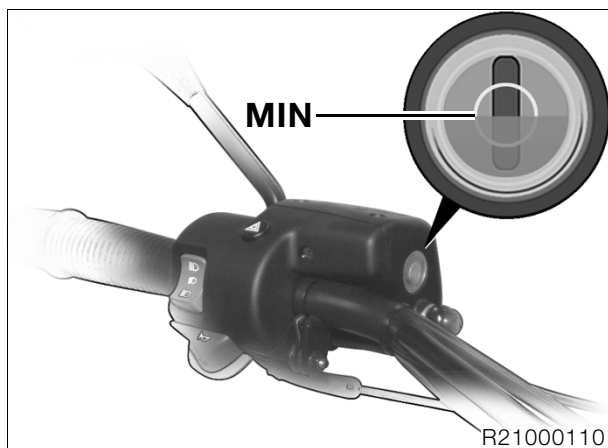

- Handlebar centred.
- Check that the front wheel is on the ground.

Fluid level:

not below MIN (halfway up sight glass)

- Turn the handlebars to the left.
- Check that the front wheel is on the ground.

Required level with a new clutch liner:
 Half way up sight glass

Note:

As the clutch lining wears, the fluid level in the reservoir rises.

- Correct the fluid level if necessary. Mark in reservoir: same as brake circuit.

Caution:

Do not allow brake fluid to come into contact with painted parts of the motorcycle as brake fluid destroys paint.

Brake fluid gradeDOT 4

Changing the clutch fluid

(Inspections IV)
 at the latest every 2 years

Caution:

Do not allow brake fluid to come into contact with painted parts of the motorcycle as brake fluid destroys paint.

Note:

The description applies to a brake system filling and bleeding device with vacuum extraction of brake fluid at the bleed line. If other devices are used, comply with their manufacturers' instructions.

- Motorcycle standing upright.
- Release clamps securing handlebar.
- Turn the front wheel and the handlebar to a position in which the clutch fluid reservoir is horizontal.
- Tighten the handlebar and secure the front wheel in this position.
- Remove reservoir cover with rubber diaphragm.
- Top up the brake fluid.

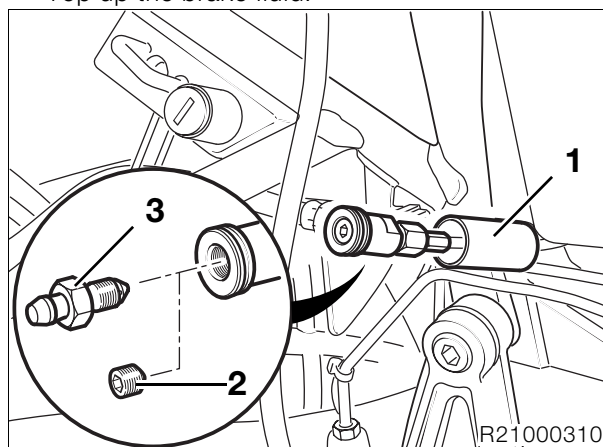

- Pull back protective hose (1).
- Wrap a cloth around the filler adapter.
- Remove socket-head grub screw (2) from the filler adapter.
- Connect the brake bleeding device to bleed screw (3).
- Screw the bleed screw all the way into the filler adapter (valve in filler adapter closed).
- Open the bleed screw by half a turn (valve open).
- Draw off brake fluid until it emerges clear and free from air bubbles.

Caution:

While bleeding the system, do not allow the brake fluid level to drop below the bottom edge of the ring mark, as otherwise air will be drawn into the clutch system. Bleed the system again if this happens.

- Remove the bleed screw.

- Disconnect the brake bleeding device from the bleed screw.
- Reinstall socket-head grub screw (2) in the filler adapter.



Caution:

The motorcycle is not permitted on the road without the grub screw in place and secure in the filler adapter.

- Correct the fluid level.
- Reinstall the reservoir lid with rubber diaphragm in position.
- Tighten the reservoir cover carefully and without using force.
- Align the clutch fitting with the mark on the handlebar.
- Resecure the handlebar in the correct position (punch marks aligned).
- Recheck the fluid level.



Tightening torque:

Grub screw in filler adapter 10 Nm
 Handlebar to fork bridge 21 Nm

Consumables

Brake fluid DOT 4

Checking tightness of rear wheel studs

(Inspection I)

- Tighten the rear wheel studs with a torque wrench.



Tightening torque:

Rear wheel studs 105 Nm



Checking rear wheel bearing play by tilting wheel

(Inspection III)

- Tilt the rear wheel to and fro across its axle.
- If play is detected, fit new shims to rear wheel drive or replace bearings.

Checking swinging arm bearings, adjusting if necessary

(Inspections I and III)

- Grip rear tyre and try to move it sideways, bracing against the frame.

Greasing the side stand pivot

(Inspections I, II and III)

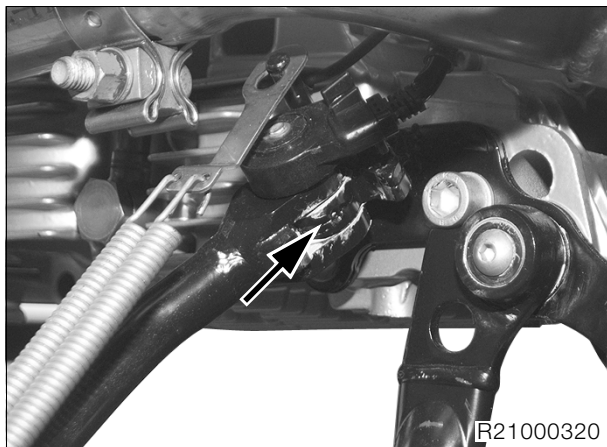

- Check free movement of side stand and grease if necessary.
- Grease pivot point (arrow).

Lubricant:

For side stand pivot..... Shell Retinax EP2

Checking function of side stand contact switch

(Inspections I, II, III and IV)

- Place the motorcycle on its centre stand.
- Retract the side stand, if extended.
- Disengage the clutch and select a gear.
- Start the engine, without releasing the clutch lever.
- Extend the side stand.



Note:

The side-stand switch is in correct working order if the engine stops when the side stand is extended.

Checking/replacing spark plugs

(Inspection II) check/(Inspection III) replace

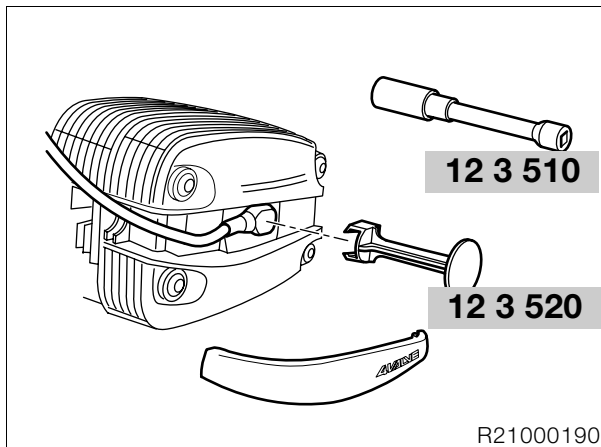

- Pull off spark plug caps with special puller, **BMW No. 12 3 520**.
- Remove spark plugs with the spark plug wrench, **BMW No. 12 3 510**.



Caution:

Do not bend electrodes - risk of breakage!

Electrode gap: 0.8 mm (0.031 in)

Wear limit: 1.0 mm (0.04 in)



Tightening torque:

Spark plug 20 Nm

Tightening cylinder heads

(Inspection I)

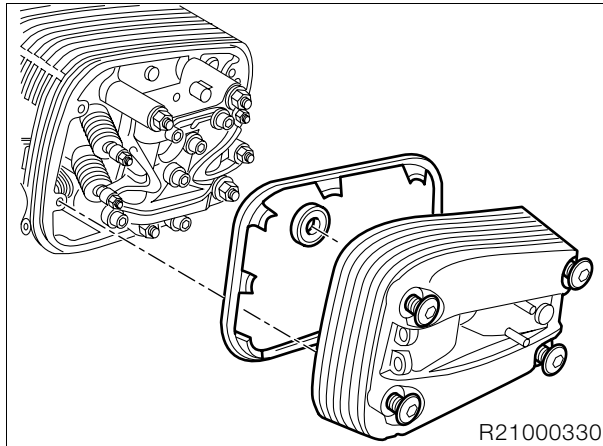

- Remove cylinder head cover.



Caution:
Catch escaping oil.

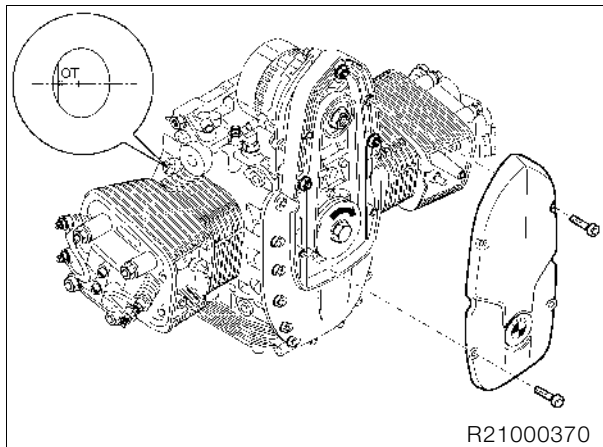

- Select a gear and turn the rear wheel, or set the piston to TDC on the ignition stroke by turning the belt pulley.

Top dead centre on ignition stroke:

- The TDC mark is visible and the inlet and exhaust valves in the cylinder concerned are closed.
- Tighten cylinder head nuts.

Tightening procedure after 1,000 km (600 miles)

1. Tighten the cylinder head nuts one after the other diagonally opposite sequence
 - 1.1. Slacken off one nut at a time
 - 1.2. Tighten nut to initial torque 20 Nm
 - 1.3. Tighten nut to specified wrench angle 180°
2. Slacken and retighten M 10 screw 40 Nm

Checking/adjusting valve clearances

(Inspections I, II and III)

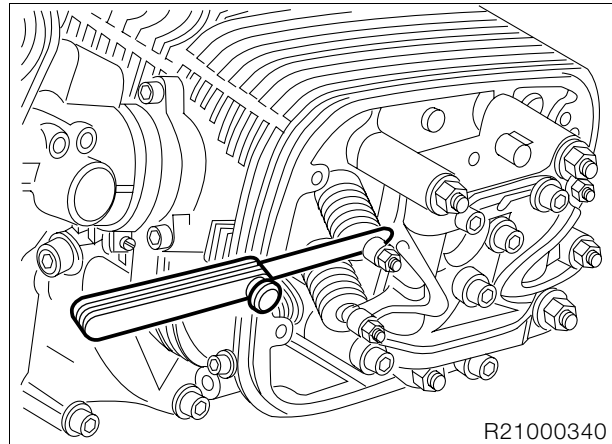

- Check valve clearance with feeler gauge and, if necessary, correct with adjusting screw.

Valve clearances with engine cold (max. 35 °C/95 °F):

Inlet 0.15 mm (0.006 in)
Exhaust 0.30 mm (0.012 in)



Tightening torque:

Locknut 8 Nm

- Recheck valve clearances after adjusting. Feeler gauge must pull through between valve stem and adjusting screw with slight resistance.
- Assembly is the reverse of the disassembly procedure.



Caution:

Make sure that all seals are correctly seated. Seals and sealing faces must be free from oil and grease.



Tightening torque:

Cylinder head cover 8 Nm

Checking freedom of throttle cable, checking for chaffing and kinks, replacing if necessary
Checking throttle-cable play
Checking and adjusting idle speed and throttle-valve synchronisation



(Inspections I, II and III)

- Test-drive the motorcycle until the engine is warm, or allow the engine to idle for approximately 10 minutes.

⚠ Caution:

Do not allow the engine to idle for longer than 20 minutes.

Oil temperature:at least 90 °C (130 °F)

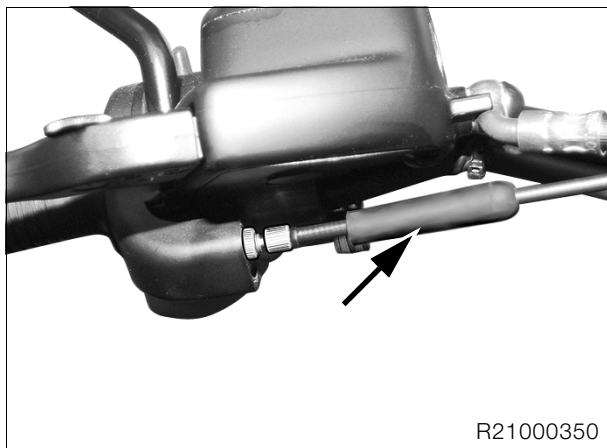

- Push back rubber cap (arrow) on throttle and choke cables.
- Use the adjusting screws to adjust play of throttle and choke cables.

Play of choke cable: approx. 1 mm (0.04 in)

Play of throttle cable: approx. 1 mm (0.04 in)

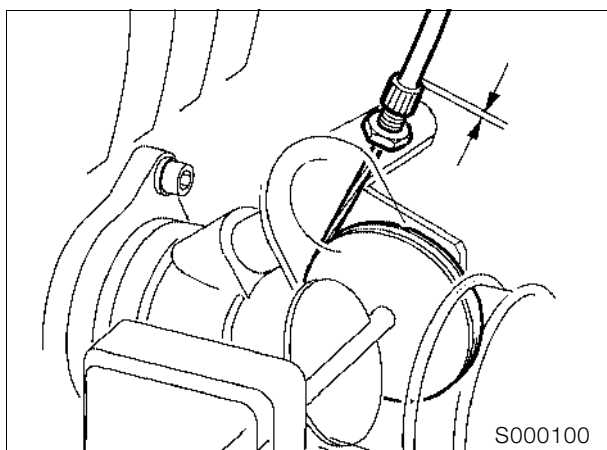

- Turn the adjusting screws to adjust the play of the cables for the left and right throttle valves.

Play of throttle cable: approx. 2 mm (0.08 in)

- Connect hose of **BMW** Synchro to vacuum adapter and connect cables to **BMW** MoDiTeC.
- Adjust idle speed by turning the air bypass screws while checking that the carburettors are balanced.

Idle speed:1,100 ±50 rpm



Note:

Make sure that both throttle valves are closed.



Caution:

Do not tamper with the sealed stop screws of the throttle valves, as otherwise the idle-speed volume flow will have to be reset by the manufacturer

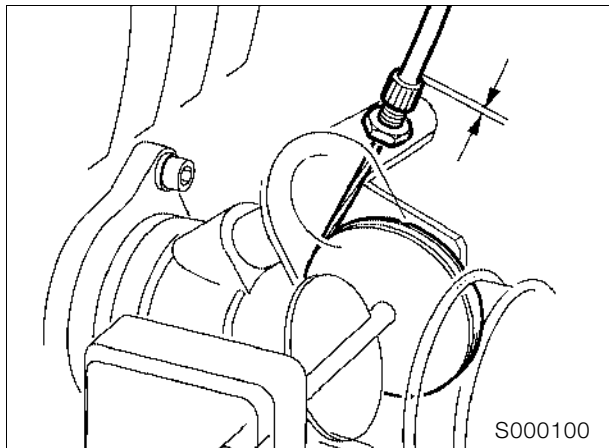

- Carefully turn the adjusting screw of the left throttle valve and reduce play until the reading of the Synchro tester changes.
- Turn the adjusting screw very slightly in the opposite direction until the reading returns to its original value.
- Tighten the locknut to secure.



Note:

Make sure that the reading does not change when you tighten the locknut.

- Adjust the right throttle valve in the same way.



Note:

Zero play can cause the throttle valves to rattle.

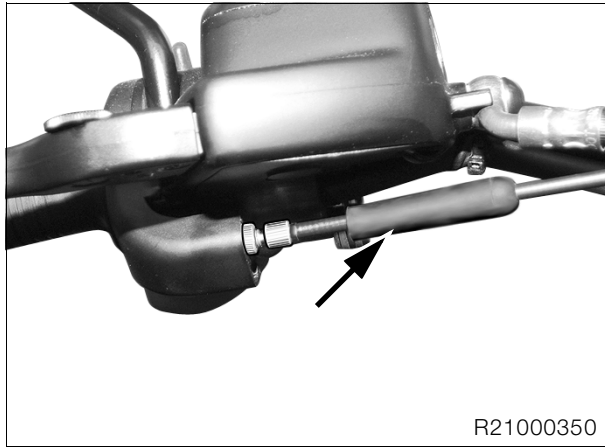

- Use the adjusting screws (arrow) to adjust play of the throttle cables.
- Push the rubber cap into position over the adjusting screw.

Play of throttle cable: approx. 0.5 mm (0.02 in)

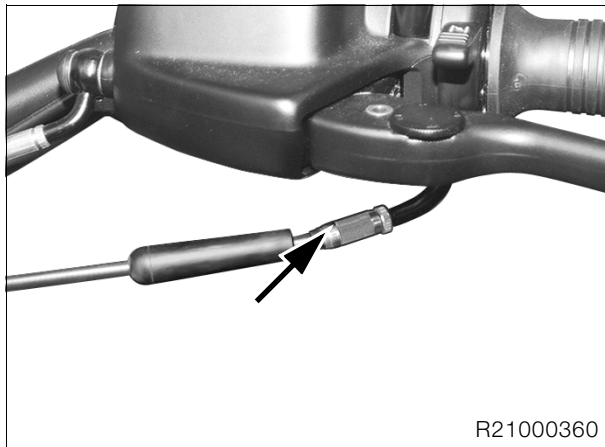

- Use the adjusting screw (arrow) to adjust play of the choke cable to zero.
- Push the rubber cap into position over the adjusting screw.
- Move the handlebars all the way from left to right and check the settings. Make sure that engine speed does not vary when the handlebars are moved in this way.
- Repeatedly open the throttle gradually and increase engine speed from idle to approximately $n = 2,500$ rpm to check throttle-valve synchronization. (Readings shown by Synchro tester must increase and decrease together). If necessary, correct by turning the adjusting screws of the throttle-valve Bowden cable.



Note:

Make sure that when the throttle grip is released both throttle valves return to their fully closed positions.

- Tighten the locknuts and recheck carburettor balance.
- Seal off the vacuum bores.

Final inspection with road safety and functional check

(Inspections I, II, III and IV)

Road safety check

- Check wheels and tyres.
- Check/correct tyre pressures.
- Wait at least 10 minutes after the trial run/road test before checking/correcting engine oil level.

Tyre pressures:

Solo	front 2.2 bar (31.3 psi)
.....	rear 2.5 bar (35.6 psi)
Two-up	front 2.5 bar (35.6 psi)
.....	rear 2.7 bar (38.4 psi)
Two-up + luggage	front 2.5 bar (35.6 psi)
.....	rear 2.9 bar (41.2 psi)

Roadworthiness check

- Lights
- Telltale/warning lights
- Horn
- Instruments
- Special equipment
- Clutch
- Gear shift
- Steering
- Foot brake and handbrake
- If necessary, take the motorcycle for a test ride.



11 Engine

Contents

Page

Technical Data	5
Cutaway drawing of engine	12
Lubricating-oil circuit	13
Cooling-oil circuit	14
Removing engine	15
Installing auxiliary frame (Raising frame unit clear of engine)	17
Removing auxiliary frame (Lowering frame unit onto engine)	18
Disassembling engine	19
Removing cylinder head cover	20
Locking the engine at TDC	21
Firing TDC	21
Removing and installing chain tensioner	22
Work instructions, timing-chain tensioner	22
Remove valve gear carrier	23
Disassembling/assembling valve gear carrier	24
Removing cylinder head	26
Disassembling, checking, repairing and reassembling cylinder head	27
Removing and installing valves	27
Removing valve stem seals	27
Checking valves for wear	28
Remachining valve seat	28
Checking and repairing cylinder head	28
Checking valve guide for wear	28
Replacing valve guides	29
Installing valve and valve stem seal	30
Removing cylinder	31
Removing and disassembling piston	31
Checking pistons and cylinders	32
Assembling pistons	32
Removing and installing conrod	33
Removing and installing alternator mount cover with engine installed	34

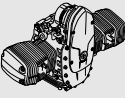

Contents

Page

Removing alternator mount cover	34
Replacing radial shaft seal in alternator mount cover	34
Removing auxiliary shaft drive	35
Removing oil pump	36
Removing radial shaft seal from crankshaft with engine installed	37
Disassembling crankcase	38
Removing crankshaft, auxiliary shaft and timing chain tensioning and slide rails	40
Removing and installing oil intake strainers	41
Replacing oil level sight glass	41
Removing and installing oil thermostat	41
Removing conrods	41
Checking conrods	41
Measuring crankshaft bearing play	42
Measuring radial bearing play	42
Installing main bearings	43
Measuring axial bearing play	43
Measuring big end bearing play	44
Assembling engine	45
Installing conrods	45
Installing crankshaft	46
Installing timing chain tensioning and slide rails	46
Installing auxiliary shaft/timing chains	46
Assembling engine block	47
Installing radial shaft seals on crankshaft	50
Installing the crankshaft-end radial shaft seal	50
Installing the clutch-end radial shaft seal	50
Installing clutch housing	51
.....	51
Installing oil pump	52
Installing auxiliary shaft drive	53
Installing piston	54

Contents

Page

Installing cylinder	55
Installing cylinder head	56
Adjusting valve clearances	57
Installing right cylinder head	58
Adjustment specification	58
Installing left cylinder head	59
Adjustment specification	59
Installing alternator mount cover	61
Installing magnetic gate/belt pulley	61
Timing the ignition	62
Installing alternator	63
Installing engine	64

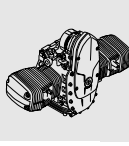

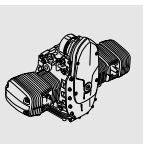

Technical Data		R 1150 GS	
Engine, general			
Engine design	Four-stroke flat twin, air-cooled with oil-cooled exhaust ports, installed longitudinally, 4 valves per cylinder, two overhead camshafts, electronic fuel injection.		
Location of engine number	Crankcase		
Cylinder bore	mm (in)	101 (3.97)	
Stroke	mm (in)	70.5 (2.78)	
Effective displacement	cc	1,130	
Compression ratio	10.3 : 1		
Power output	kW/(bhp)/rpm	62.5/(85)/6,750	
Max. torque	Nm/rpm	98/5,250	
Permissible maximum engine speed	rpm	7,900	
Idle speed	rpm	1,100 ⁺⁵⁰	
Direction of rotation	Clockwise, looking at ignition system		
Compression test pressure			
good	bar (psi)	above	10 (142)
normal	bar (psi)		8.5 ... 10 (121 ... 142)
poor	bar (psi)	below	8.5 (121)
Intake port dia./cylinder head	mm (in)	44 (1.7)	
Lubrication system			
Theoretical volume in circulation at 6,000 rpm			
Lubricating oil	l (Imp.gal/ US gal)	30 (6.6/7.9)	
Cooling oil	l (Imp.gal/ US gal)	33 (7.3/8.7)	
Oil filter	Full-flow type		
Pressure differential needed to open bypass valve	bar (psi)	1.5 (21.3)	
Oil pressure warning light comes on below	bar (psi)	0.3 (4.2)	
Pressure relief valve opens at	bar (psi)	5.5 (78.3)	
Operating pressure	bar (psi)	3.5 ... 6.0 (49.8 ... 85.4)	
Oil content without filter change	l (Imp.pint/ US quart)	3.50 (6.16/3.70)	
with filter change	l (Imp.pint/ US quart)	3.75 (6.60/3.96)	
min/max	l (Imp.pint/ US quart)	0.5 (0.88/0.53)	
Permissible oil consumption	l/1,000 km (miles per Imp.pint/miles per US quart)	1.0 (350/390)	
Oil pump			
Oil capacity	2 Duocentric pumps		
Housing depth			
Cooling oil	mm (in)	11.02 ... 11.05 (0.434 ... 0.435)	
Lube oil	mm (in)	10.02 ... 10.05 (0.394 ... 0.396)	
Height of rotor			
Cooling oil	mm (in)	10.965 ... 10.98 (0.431 ... 0.432)	
Lube oil	mm (in)	9.965 ... 9.98 (0.392 ... 0.393)	
Axial play	mm (in)	0.04 ... 0.085 (0.002 ... 0.003)	
Wear limit	mm (in)	0.25 (0.010)	

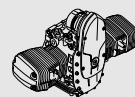

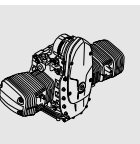

Technical Data		R 1150 GS
Valves		
Included angle between valves	°	41
Valve clearances with engine cold (max. 35 °C/95 °F)		
Inlet valve	mm (in)	0.15 (0.006)
Exhaust valve	mm (in)	0.30 (0.012)
Valve timing		without valve clearance, 3 mm (0.12 in) valve lift
Inlet opens	°	1 after TDC
Inlet closes	°	25 after BDC
Exhaust opens	°	31 before BDC
Exhaust closes	°	13 before TDC
		° Tolerance ± 3
Valve head dia.		
Inlet	mm (in)	34 (1.34)
Exhaust	mm (in)	29 (1.14)
Stem dia.		
Inlet	mm (in)	4.966 ... 4.980 (0.1955 ... 0.1960)
Wear limit	mm (in)	4.946 (0.1947)
Exhaust	mm (in)	4.956...4.970 (0.1951...0.1956)
Wear limit	mm (in)	4.936 (0.1943)
Valve head edge thickness		
Inlet	mm (in)	1.00 ± 0.2 (0.04 ± 0.008)
Wear limit	mm (in)	0.5 (0.02)
Exhaust	mm (in)	0.9 ± 0.2 (0.003 ± 0.008)
Wear limit	mm (in)	0.5 (0.02)
Max. runout of valve head at valve seat		
Inlet, exhaust	mm (in)	0.035 (0.0014)
Valve seat ring		
Valve seat angle		
Inlet	°	45
Exhaust	°	45
Valve seat width		
Inlet	mm (in)	1.1 ± 0.15 (0.043 ± 0.006)
Wear limit	mm (in)	2.5 (0.10)
Exhaust	mm (in)	1.4 ± 0.15 (0.055 ± 0.006)
Wear limit	mm (in)	3.0 (0.12)
Valve seat extl. dia. (dimension for machining seat)		
Inlet	mm (in)	33.4 ± 0.1 (1.32 ± 0.004)
Exhaust	mm (in)	28.4 ± 0.1 (1.12 ± 0.004)
Seat ring dia. (oversize +0.2 mm/+0.008 in)		
Inlet	mm (in)	36.617 ... 36.633 (1.4416 ... 1.4422)
Exhaust	mm (in)	32.134 ... 32.150 (1.2651 ... 1.2658)
Seat dia. in cylinder head (oversize +0.2 mm/+0.008 in)		
Inlet	mm (in)	36.500 ... 36.525 (1.4370 ... 1.4380)
Exhaust	mm (in)	32.000 ... 32.025 (1.2599 ... 1.2608)

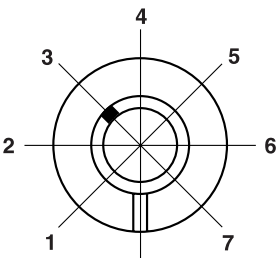
Technical Data		R 1150 GS	
Valve guide			
Valve guide	Extl. dia.	mm (in)	12.533 ... 12.544 (0.4934 ... 0.4939)
Bore in cylinder head		mm (in)	12.500 ... 12.518 (0.4921 ... 0.4928)
Overlap		mm (in)	0.015 ... 0.044 (0.0006 ... 0.0017)
Repair stages			
Replacement valve guide	Extl. dia.	mm (in)	12.550 ... 12.561 (0.4941 ... 0.4945)
Oversize valve guide	Extl. dia.	mm (in)	12.733 ... 12.744 (0.5013 ... 0.5017)
Valve guide	Intl. dia.	mm (in)	5.0 ... 5.012 (0.1969 ... 0.1973)
Radial clearance			
Inlet		mm (in)	0.020 ... 0.046 (0.0008 ... 0.0018)
Wear limit		mm (in)	0.15 (0.006)
Exhaust		mm (in)	0.030 ... 0.056 (0.0012 ... 0.0022)
Wear limit		mm (in)	0.17 (0.007)
Valve spring			
Spring length, off-load		mm (in)	41.1 (1.62)
Wear limit		mm (in)	39.0 (1.54)
Rocker			
Bore		mm (in)	16.016 ... 16.034 (0.6306 ... 0.6312)
Rocker shaft dia.		mm (in)	15.973 ... 15.984 (0.6289 ... 0.6293)
Radial clearance		mm (in)	0.032 ... 0.061 (0.0016 ... 0.0024)
Wear limit		mm (in)	0.1 (0.004)
Axial play	min.	mm (in)	0.05 (0.002)
	max.	mm (in)	0.40 (0.016)
Camshaft			
Opening angle, inlet/exhaust cams		°	284/284
Cam spread, inlet/exhaust		°	103/112
Markings			Mark in position 3
			
Inlet valve lift		mm (in)	8.50 (0.33) (valve clearance = 0)
Exhaust valve lift		mm (in)	8.19 (0.32) (valve clearance = 0)
Camshaft bearing bore		mm (in)	21.02 ... 21.04 (0.8276 ... 0.8284)
Camshaft dia.		mm (in)	20.97 ... 21.00 (0.8256 ... 0.8268)
Radial clearance		mm (in)	0.02 ... 0.07 (0.0008 ... 0.0028)
Wear limit		mm (in)	0.15 (0.006)
Width of guide bearing		mm (in)	15.92 ... 15.95 (0.6268 ... 0.6280)
Width of camshaft bearing		mm (in)	16.0 ... 16.05 (0.6299 ... 0.6319)
Axial play		mm (in)	0.05 ... 0.13 (0.0031 ... 0.0051)
Wear limit		mm (in)	0.25 (0.010)

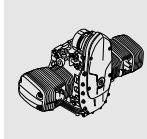

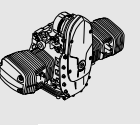

Technical Data		R 1150 GS
Bucket-type tappet		
Extl. dia.	mm (in)	23.947 ... 23.960 (0.9428 ... 0.9433)
Bore dia. in cylinder head	mm (in)	24.000 ... 24.021 (0.9449 ... 0.9457)
Radial clearance	mm (in)	0.040 ... 0.074 (0.0016 ... 0.0029)
Wear limit	mm (in)	0.18 (0.0070)
Auxiliary shaft		
Bore in crankcase front/rear	mm (in)	25.020 ... 25.041 (0.9851 ... 0.9859)
Auxiliary shaft dia. front/rear	mm (in)	24.959 ... 24.980 (0.9827 ... 0.9835)
Radial clearance	mm (in)	0.040 ... 0.082 (0.0016 ... 0.0032)
Wear limit	mm (in)	0.17 (0.0066)
Crankshaft		
Marking of main bearing and crankpin on front crank web		
no paint mark		Grinding stage 0
paint mark		Grinding stage 1 (-0.25 mm/-0.010 in)
Grinding stage 0 (grinding stage 1 = -0.25 mm/-0.01 in)		
Guide bearing bore	mm (in)	64.949 ... 64.969 (2.5571 ... 2.5579)
Guide bearing dia.	mm (in)	Green: 59.965 ... 59.999 (2.3608 ... 2.3621)
	mm (in)	Yellow: 59.979 ... 60.013 (2.3614 ... 2.3628)
Main bearing journal dia.	mm (in)	Green: 59.939 ... 59.948 (2.3598 ... 2.3602)
	mm (in)	Yellow: 59.949 ... 59.958 (2.3602 ... 2.3606)
Radial clearance	mm (in)	0.017 ... 0.060 (0.0007 ... 0.0023)
Wear limit	mm (in)	0.1 (0.0039)
Main bearing bore	mm (in)	60.010 ... 60.029 (2.3626 ... 2.3633)
Main bearing dia.	mm (in)	Green: 55.000 ... 55.039 (2.1654 ... 2.1669)
	mm (in)	Yellow: 55.008 ... 55.047 (2.1657 ... 2.1672)
Main bearing journal dia.	mm (in)	Green: 54.971 ... 54.980 (2.1643 ... 2.1646)
	mm (in)	Yellow: 54.981 ... 54.990 (2.1646 ... 2.1650)
Radial clearance	mm (in)	0.018 ... 0.066 (0.0007 ... 0.0026)
Wear limit	mm (in)	0.13 (0.0051)
Width of guide bearing	mm (in)	24.890 ... 24.940 (0.9799 ... 0.9819)
Width of main bearing journal	mm (in)	25.065 ... 25.098 (0.9868 ... 0.9881)
Axial play	mm (in)	0.125 ... 0.208 (0.0049 ... 0.0082)
Wear limit	mm (in)	0.2 (0.0079)
Grinding stage 0 (grinding stage 1 = -0.25 mm/-0.01 in)		
Crankpin dia.	mm (in)	47.975 ... 47.991 (1.8888 ... 1.8894)
Width of crankpin	mm (in)	22.065 ... 22.195 (0.8687 ... 0.8738)

Technical Data		R 1150 GS
Connecting rod		
Big-end bore	mm (in)	51.000 ... 51.013 (2.0079 ... 2.0084)
Big-end bearing dia.	mm (in)	48.016 ... 48.050 (1.8904 ... 1.8918)
Radial clearance	mm (in)	0.025 ... 0.075 (0.010 ... 0.0030)
Wear limit	mm (in)	0.13 (0.005)
Width of big-end bearing eye	mm (in)	21.883 ... 21.935 (0.8616 ... 0.8636)
Conrod end float	mm (in)	0.130 ... 0.312 (0.0051 ... 0.0123)
Wear limit	mm (in)	0.5 (0.02)
Small-end bore	mm (in)	22.015 ... 22.025 (0.8664 ... 0.8671)
Radial clearance	mm (in)	0.015 ... 0.030 (0.0006 ... 0.0012)
Wear limit	mm (in)	0.06 (0.002)
Distance between centers	mm (in)	125 (4.92)
Max. deviation from parallel of conrod bores at distance of 150 mm (5.90 in)	mm (in)	0.02 (0.00079)
Weight classes		
Class		
0 (2 spots, white)	grammes (oz.)	520.0 ... 525.9 (18.356 ... 18.565)
1 (2 spots, blue)	grammes (oz.)	526.0 ... 531.9 (18.568 ... 18.776)
2 (3 spots, white)	grammes (oz.)	532.0 ... 537.9 (18.78 ... 18.988)
3 (3 spots, yellow)	grammes (oz.)	538.0 ... 543.9 (18.992 ... 19.20)
4 (1 spot, blue)	grammes (oz.)	544.0 ... 549.9 (19.201 ... 19.412)
Cylinders		
Bore		(20 mm/0.79 in from top edge)
A	mm (in)	100.992 ... 101.000 (3.9761 ... 3.9764)
Wear limit	mm (in)	101.050 (3.9784)
B	mm (in)	101.000 ... 101.008 (3.9764 ... 3.9768)
Wear limit	mm (in)	101.058 (3.9787)
Total wear clearance of piston and cylinder	mm (in)	0.12 (0.005)
Permitted out-of-roundness of cylinder bore at 20 mm (0.7874 in) from the top edge	mm (in)	0.03 (0.0012)
at 100 mm (3.9370 in) from the top edge	mm (in)	0.04 (0.0016)

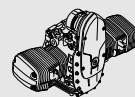

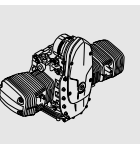

Technical Data		R 1150 GS	
Pistons			
Piston dia.		(Measuring plane A – see Checking pistons and cylinders)	
A	mm (in)	100.971 ... 100.983 (3.9753 ... 3.9758)	
Wear limit	mm (in)	100.895 (3.9723)	
B	mm (in)	100.983 ... 100.995 (3.9757 ... 3.9763)	
Wear limit	mm (in)	100.905 (3.9727)	
AB	mm (in)	100.979 ... 100.987 (3.9756 ... 3.9759)	
Wear limit	mm (in)	100.900 (3.9725)	
Installed clearance		mm (in)	0.005 ... 0.029 (0.0002 ... 0.0011)
Total wear clearance of piston and cylinder		mm (in)	0.12 (0.005)
Piston pin bore		mm (in)	22.005 ... 22.011 (0.8664 ... 0.8666)
Weight classes		+ and –	
Weight difference in one class		grammes (oz.)	10 (0.353) (complete with pins and rings)
Direction of installation		Arrow on piston crown pointing to exhaust side Production locating point towards exhaust side (see Installing piston)	
Piston rings			
1st groove	Piston ring asymmetric, convex oval		
	Height	mm (in)	1.170 ... 1.190 (0.0461 ... 0.0469)
	Wear limit	mm (in)	1.1 (0.04)
Ring gap		mm (in)	0.1 ... 0.3 (0.004 ... 0.012)
Wear limit		mm (in)	0.8 (0.03)
Ring float		mm (in)	0.030 ... 0.070 (0.0012 ... 0.0027)
Wear limit		mm (in)	0.15 (0.006)
2nd groove	Micro-taper compression ring		
	Height	mm (in)	1.170 ... 1.190 (0.0461 ... 0.0469)
	Wear limit	mm (in)	1.1 (0.04)
Ring gap		mm (in)	0.2 ... 0.4 (0.0078 ... 0.0158)
Wear limit		mm (in)	0.8 (0.03)
Ring float		mm (in)	0.030 ... 0.07 (0.0012 ... 0.0027)
Wear limit		mm (in)	0.15 (0.0006)
3rd groove	Coiled-spring ring		
	Height	mm (in)	1.97 ... 1.99 (0.0776 ... 0.0783)
	Wear limit	mm (in)	1.9 (0.075)
Ring gap		mm (in)	0.30 ... 0.55 (0.012 ... 0.02166)
Wear limit		mm (in)	1.20 (0.047)
Ring float		mm (in)	0.020 ... 0.060 (0.0008 ... 0.0024)
Wear limit		mm (in)	0.15 (0.006)
Installed direction of piston rings		Top marking uppermost	

Technical Data		R 1150 GS
Piston pins		
Piston pin dia.	mm (in)	21.995 ... 22.000 (0.8664 ... 0.8662)
Wear limit	mm (in)	21.960 (0.8646)
Bore in piston	mm (in)	22.005 ... 22.011 (0.8664 ... 0.8666)
Radial clearance in piston	mm (in)	0.005 ... 0.016 (0.0002 ... 0.0006)
Wear limit	mm (in)	0.070 (0.0028)

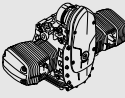

Cutaway drawing of engine

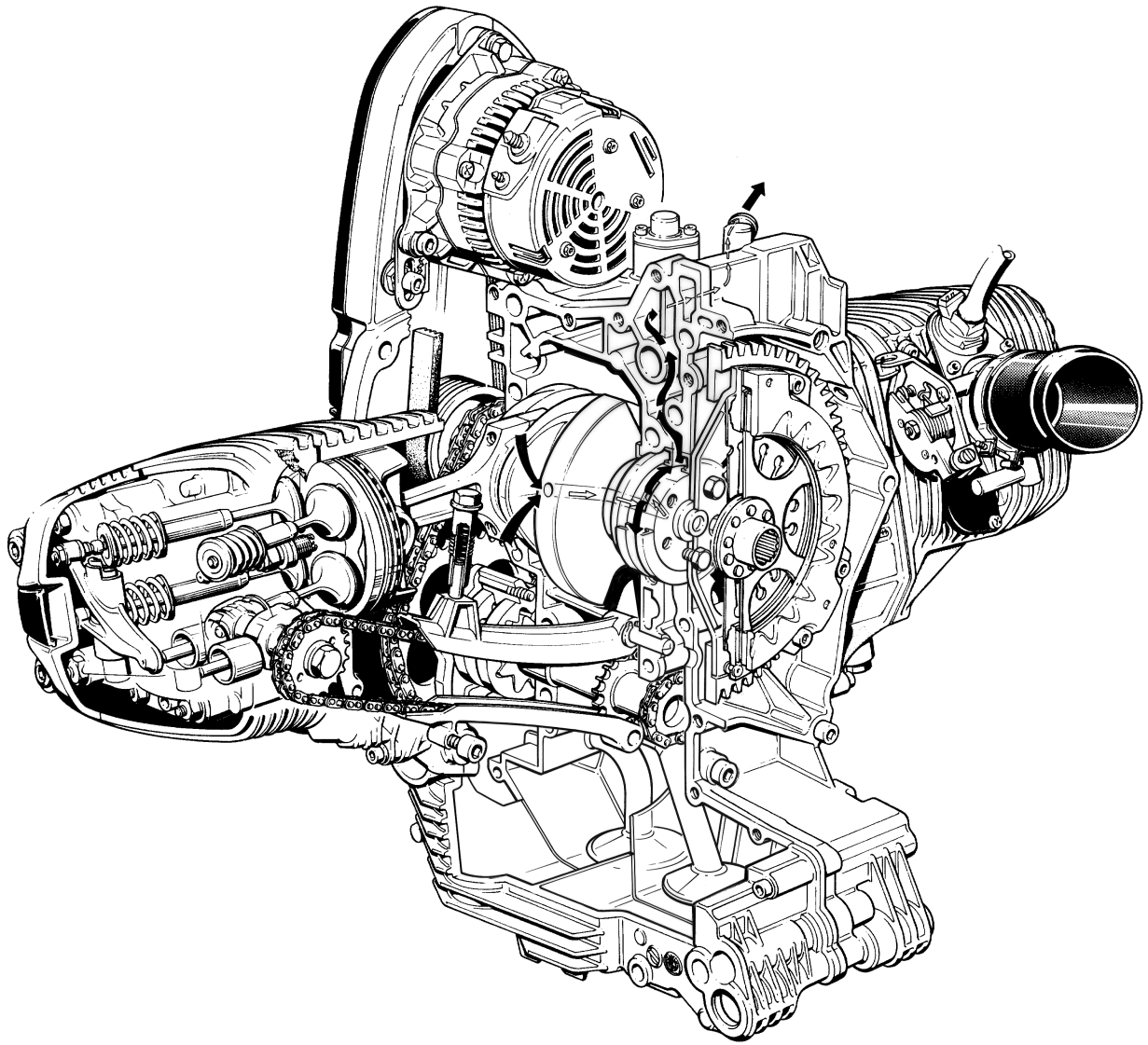
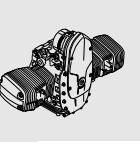

Lubricating-oil circuit

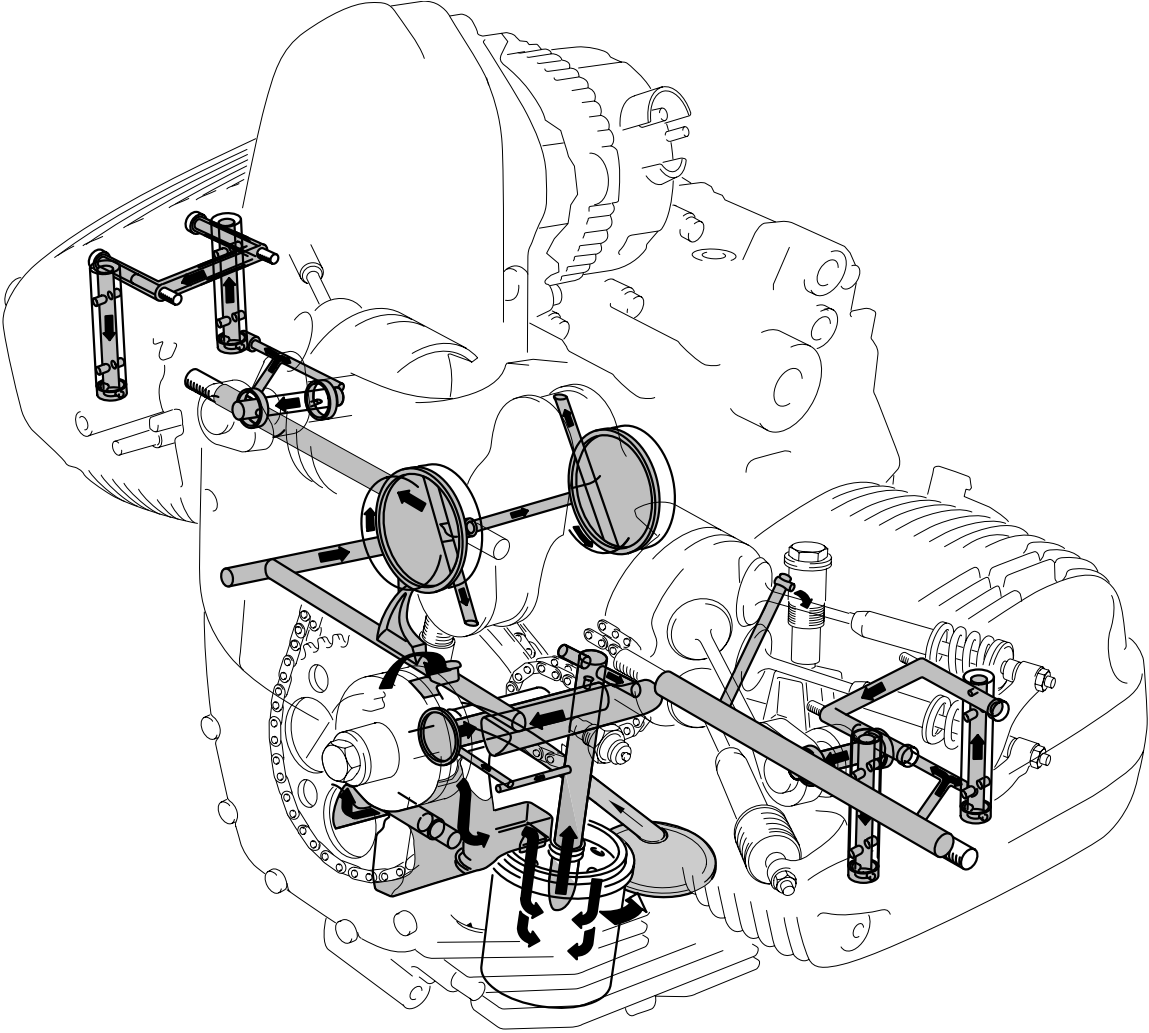
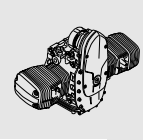

Cooling-oil circuit

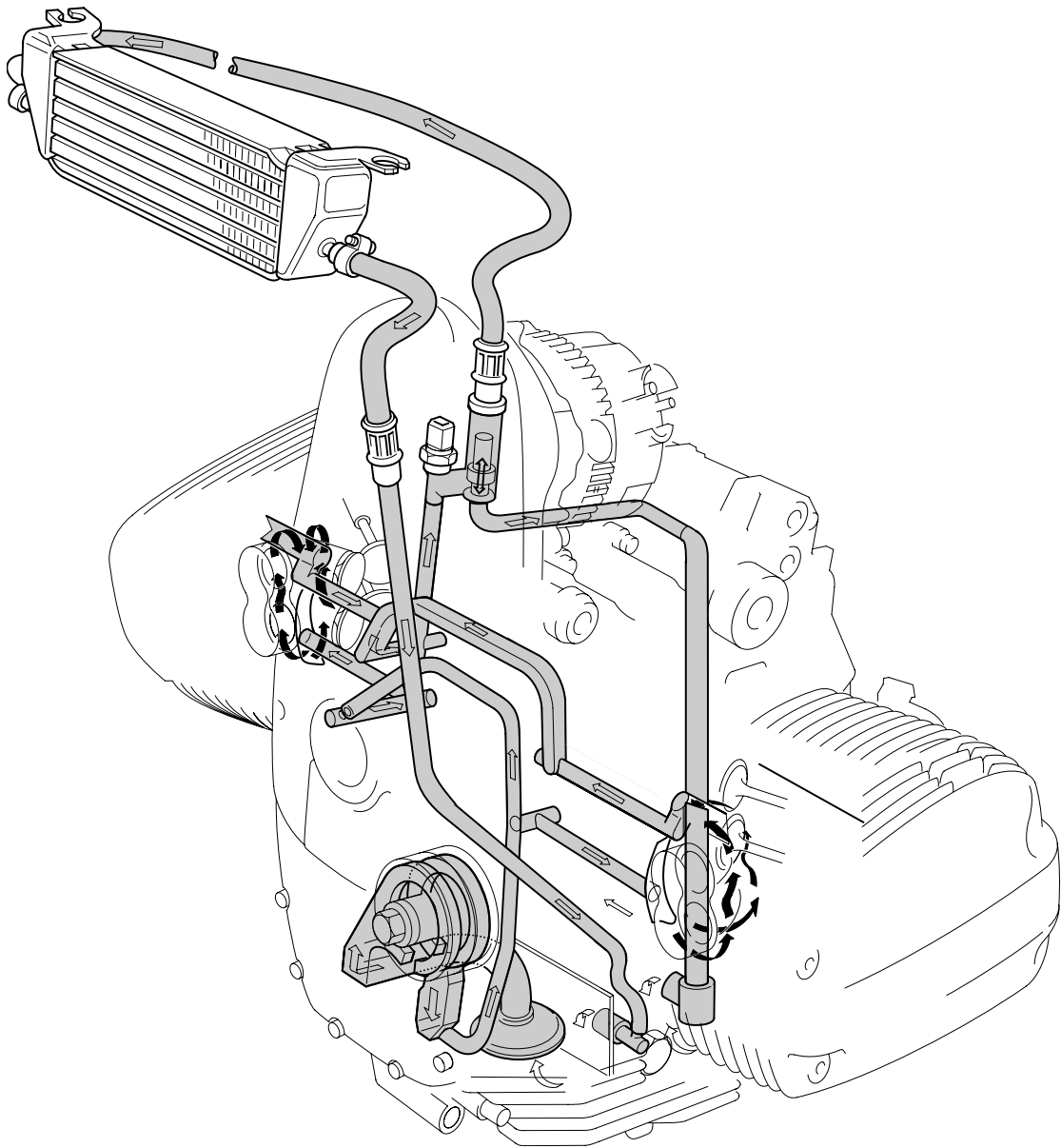
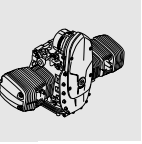

Removing engine



Note:

Auxiliary shaft, timing chains, chain tensioner/guide rails and crankshaft can only be disassembled after the engine has been removed. All other components can be disassembled with the engine installed.

- Remove the sump guard.
- Drain engine oil.

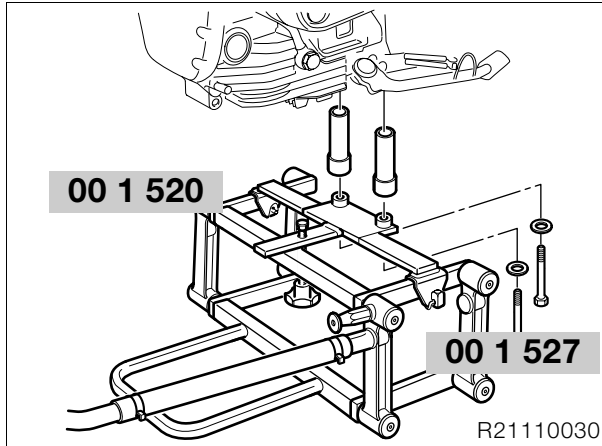

- Secure stand, **BMW No. 00 1 520**, to motorcycle with overlength bushes and screws, **BMW No. 00 1 527**.



Note:

Mount a washer on the screw on the right as viewed in the forward direction of travel. Depth of thread in tapped bore has been reduced!

- Remove the seat.
- Remove side panel.
- Remove fuel tank fastener.

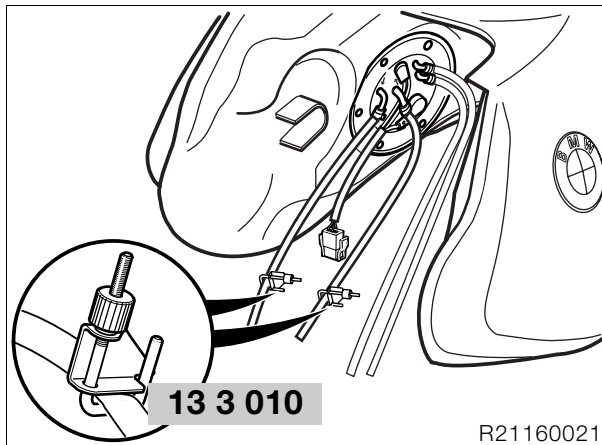

Caution:

Fuel is flammable and a hazard to health. Observe relevant safety regulations.

- Seal the fuel feed and return lines with hose clips, **BMW No. 13 3 010**, and disconnect.
- Disconnect breather lines.

- Disconnect plug of fuel pump unit.
- Remove fuel tank.
- Remove the battery.



Caution:

Disconnect negative terminal first, then positive terminal.

- Disconnect the air temperature sensor plug.
- Disconnect the diagnostic plug.
- Remove air filter cover.
- Remove the intake air pipe.
- Disconnect plug from Hall sensor.
- Remove Motronic control unit.
- Disconnect the Motronic control unit plug.
- **[ABS]** Fully drain the brake system.
- **[ABS]** Remove the unit.



Caution:

Always follow the instructions in the Repair Manual. → Group 34, removing and installing the ABS unit.



Note:

Secure the brake lines with cable ties.

- Remove actuating cable for starting-speed increase.
- Disengage throttle cable.
- Remove Bowden-cable cover from fitting for throttle actuation.
- Disengage throttle cable.
- Disengage throttle cables from right and left throttle flap stubs.
- Disengage the clamp securing the breather hose at the front of the engine.
- Disconnect the breather hose at the front.
- Remove battery holder with Bowden-cable divider.
- Remove cable ties holding the cable below the battery holder.

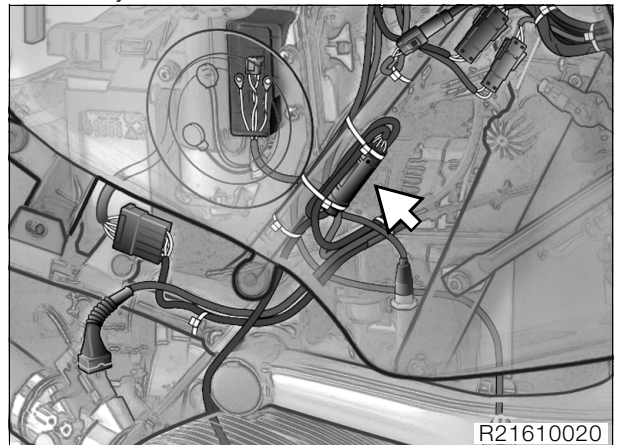

- Disconnect plug/oxygen sensor and remove cable.

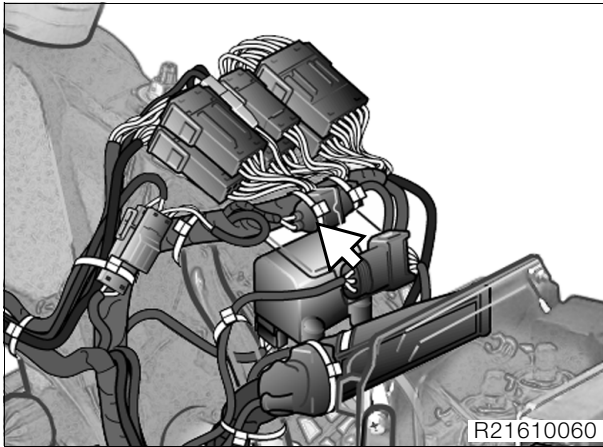
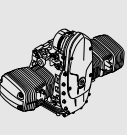

- Disconnect plug/NTC oil-temperature sensor.
- Disconnect the leads from the alternator.
- Disconnect ground lead from terminal at top of engine.
- Disconnect right oil cooler line from engine.
- Remove spark plug covers.

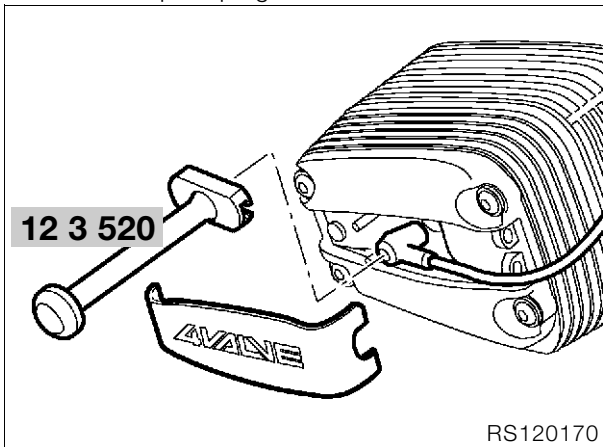

- Pull off spark plug cap with special puller, **BMW No. 12 3 520**.
- Disconnect plugs of injection valves.
- Disconnect hose clamps/throttle stub pipes and push the stubs into the air filter box.
- Disconnect ground cable from left throttle stub pipe.
- Disconnect plug of throttle-valve potentiometer.
- Remove holders of injection valves.
- Remove injection valves from throttle stub pipe.
- Remove throttle stub pipe.
- Loosen the fasteners securing the right and left footrest plates.
- Remove top screws on left and right.



Note:

When installing the footrest plates, use the long screws on the right and the short screws on the left.

- Remove front fasteners of rear frame on left and right.
- Remove manifold.
- Remove rear silencer.
- Remove front silencer.
- Remove starter motor cover and disconnect cable to power socket.
- Disconnect cables from starter motor.
- Remove the starter motor.
- Disconnect cable from oil pressure switch.

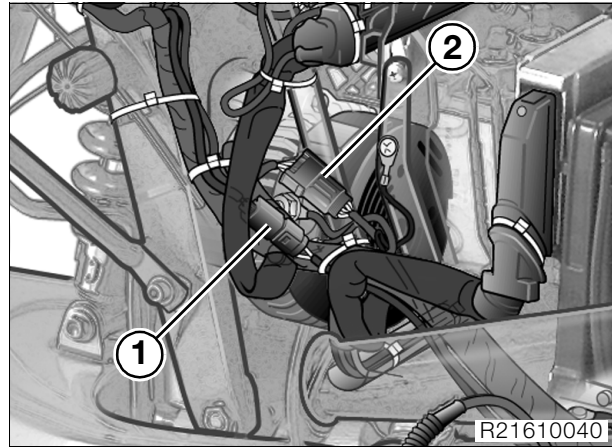

- Disconnect plug (1) of side-stand switch.
- Disconnect plug (2) of gear indicator.
- Remove front cover.
- Disconnect left oil cooler line from engine.
- Remove rear brake fluid reservoir from its holder.
- **[ABS]** Remove ABS sensor from rear wheel drive.
- Remove rear brake caliper.
- Disconnect brake line from swinging arm.
- Use cable ties to secure the brake caliper to the rear frame.

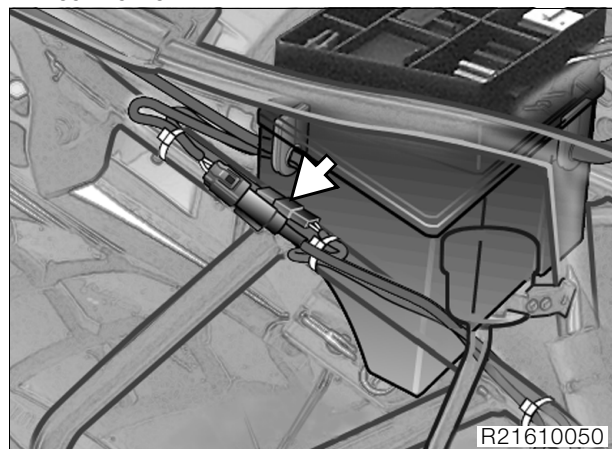

- Disconnect plug of rear brake light switch.
- Remove fasteners of guard and rear brake master cylinder.
- Use masking tape to cover the rear flow brake line in the vicinity of the fastener securing the rear frame to the gearbox.
- Remove the main stand and the side stand.
- Remove the leading link caps.
- Remove the left screw cap.
- Remove retaining ring on right.
- Remove cap.
- Remove the screw on the right.



Caution:

If necessary, mask off the leading link to prevent it from being scratched.

- Pull the shaft of the leading link out to the left.

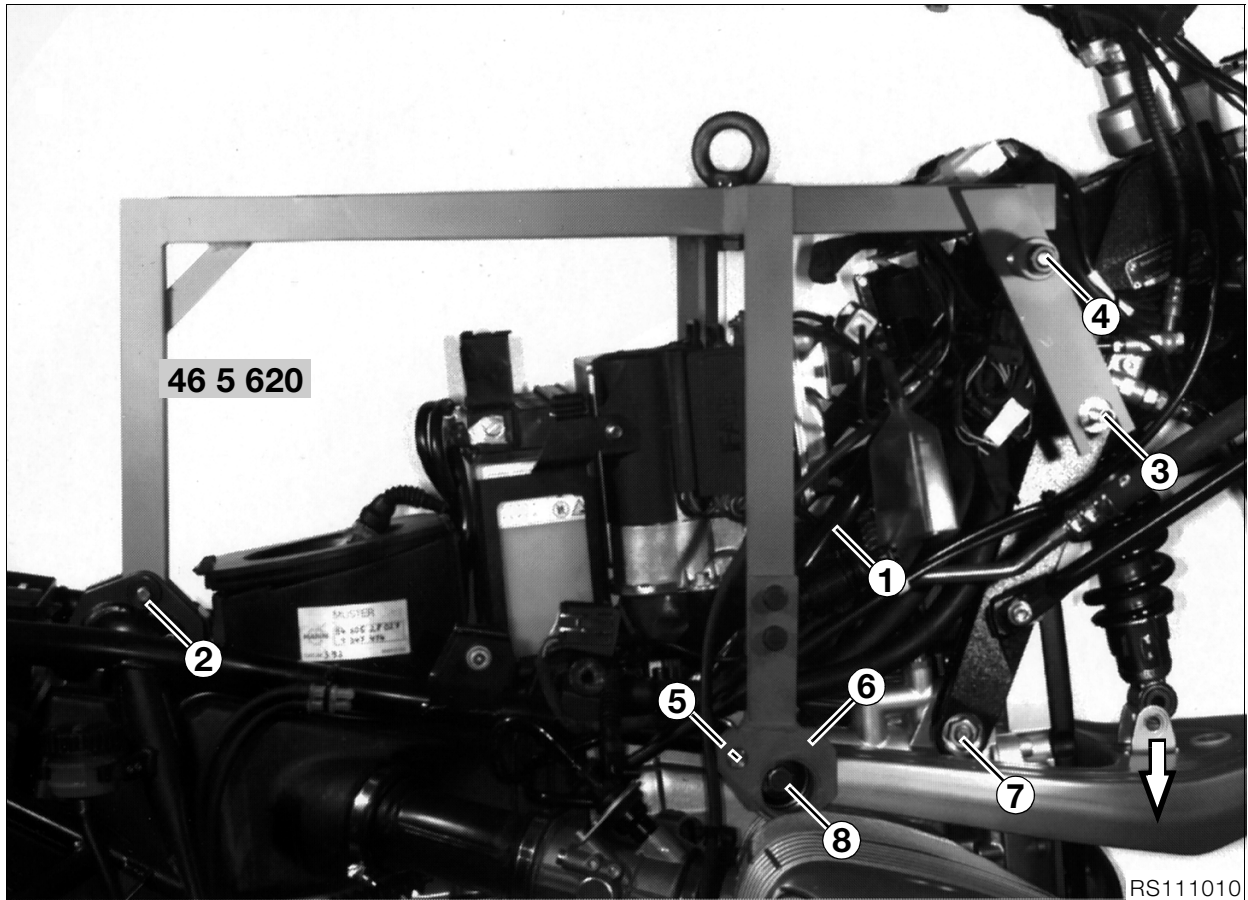

Installing auxiliary frame (Raising frame unit clear of engine)

- Remove rear wheel.
- Remove height adjuster from seat on right.
- Remove hydraulic spring-strut adjuster.
- Remove rear spring strut.
- Install the rear wheel.
- Remove the upper securing screw and the bottom bolt of the engine/frame connecting strut (1).
- Place auxiliary frame, **BMW No. 46 5 630**, in position and secure to the rear spring-strut mount (2).
- Engage the auxiliary frame to the front anchorage point for the fuel tank (3).

Caution:

Use adhesive tape to mask the fuel tank anchorage and protect it against scratches.

- Align the auxiliary frame with the flat of the fuel-tank anchorage, install the threaded bushings (4) at the connecting struts/frame and tighten.
- Remove front fasteners for rear frame (5) on left and right.
- Install adapter (6) in link/rear-frame anchorage and secure to auxiliary frame.
- Remove the fastener securing the front spring strut at the bottom.
- Press leading link down at front (arrow), or pull tail section down.

- Remove bolt (7) securing the frame to the engine.
- Secure the front spring strut at the bottom.
- Slightly raise the frame unit at the front and remove the fasteners securing the clutch slave cylinder.
- Raise the frame unit at the front.

Caution:

When raising the frame unit, take care not to damage the oil line on the engine at the front.

- Remove the gearbox, swinging arm, rear axle and rear wheel together.

Removing auxiliary frame (Lowering frame unit onto engine)

- Lower the frame unit into position from front.



Caution:

Make sure that all components are correctly positioned. Do not damage cables, lines and Bowden cables.

- Install the clutch slave cylinder.
- Lightly grease the shaft of the leading link, insert it from the left and tighten.
- Remove the fastener securing the front spring strut at the bottom.
- Press leading link down at front, or pull tail section down.



Caution:

If necessary, mask off the leading link to prevent it from being scratched.

- Insert pin, **BMW No. 46 5 630**, from the left to align the front frame bores with the corresponding bores in the engine, insert the bolts from the right and tighten.
- Secure the front spring strut at the bottom.
- Remove the auxiliary frame.

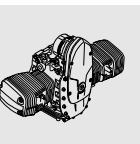

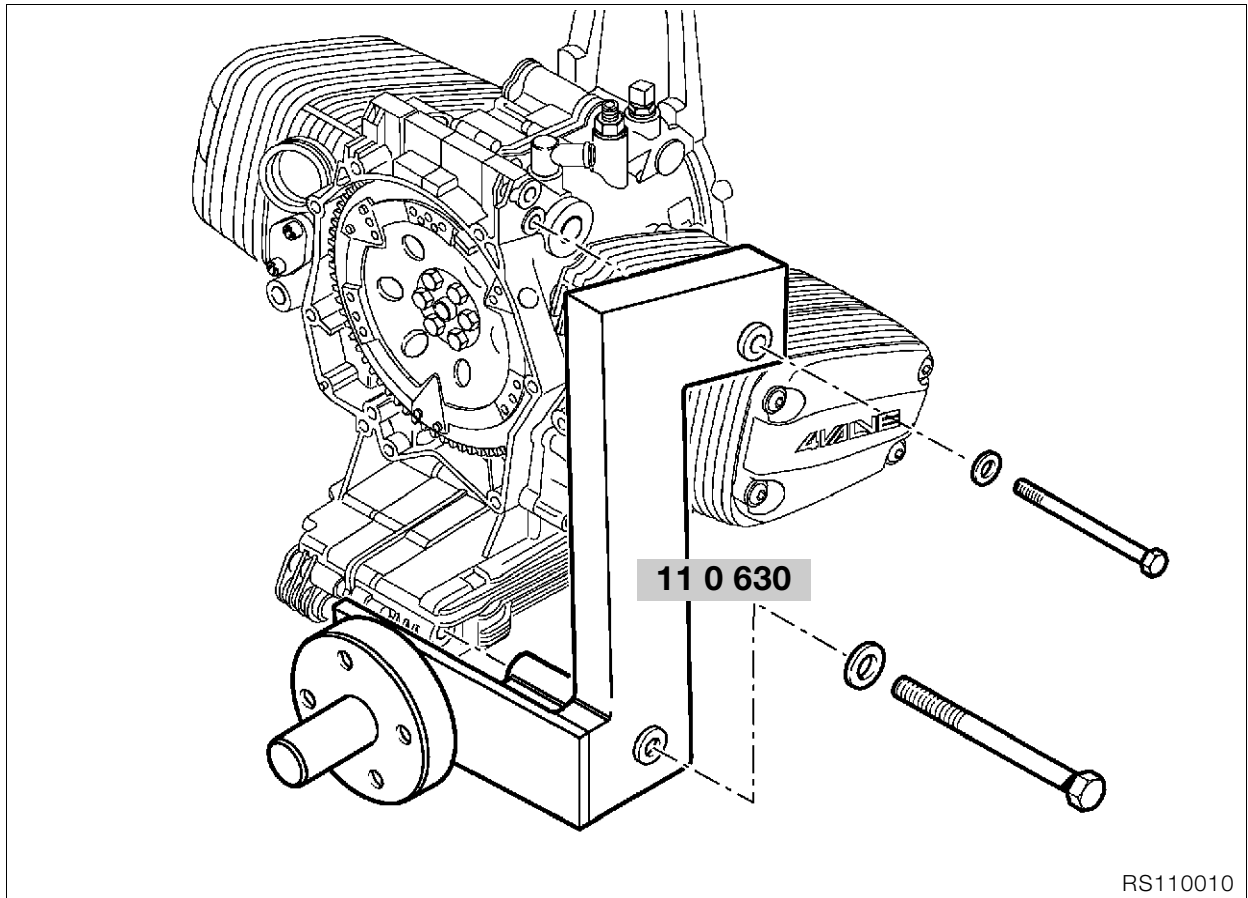

Disassembling engine

- Secure engine mount, **BMW No. 11 0 630**, to the engine block.
- Transfer engine to assembly frame.

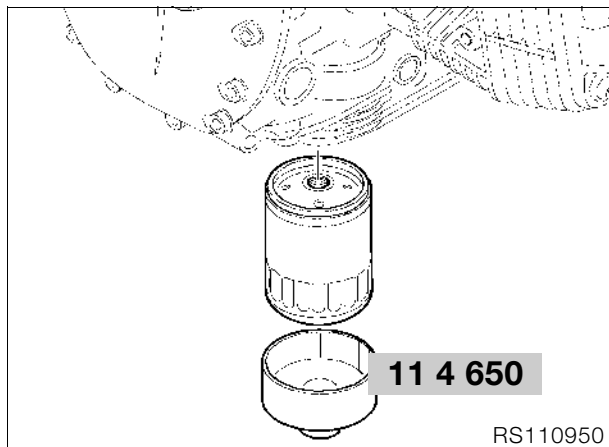

- Drain engine oil.
- Remove the oil filter, using oil filter wrench, **BMW No. 11 4 650**.

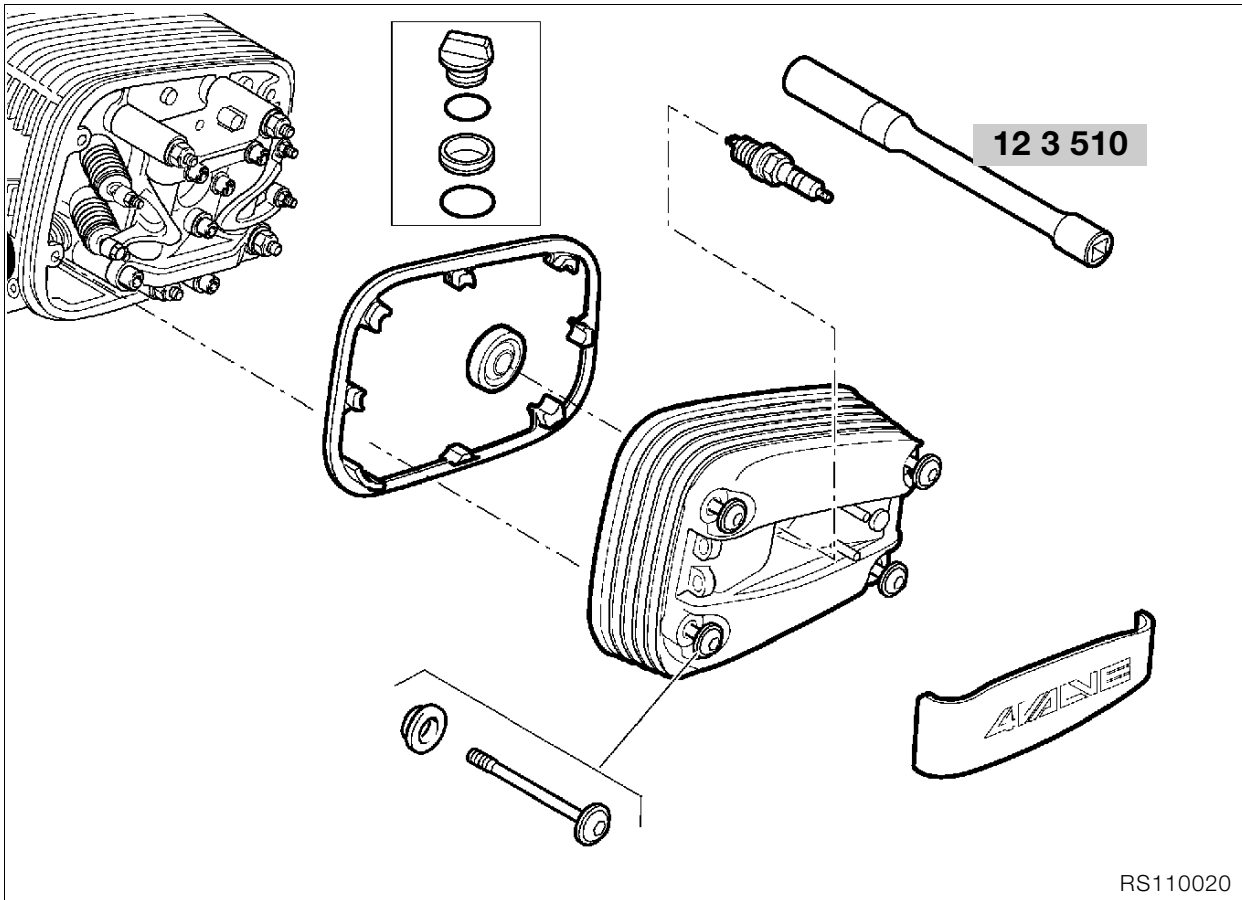

Removing cylinder head cover

- Remove spark plugs with the spark plug wrench, **BMW No. 12 3 510**.
- Remove cylinder head cover.

⚠ Caution:
Catch escaping oil.

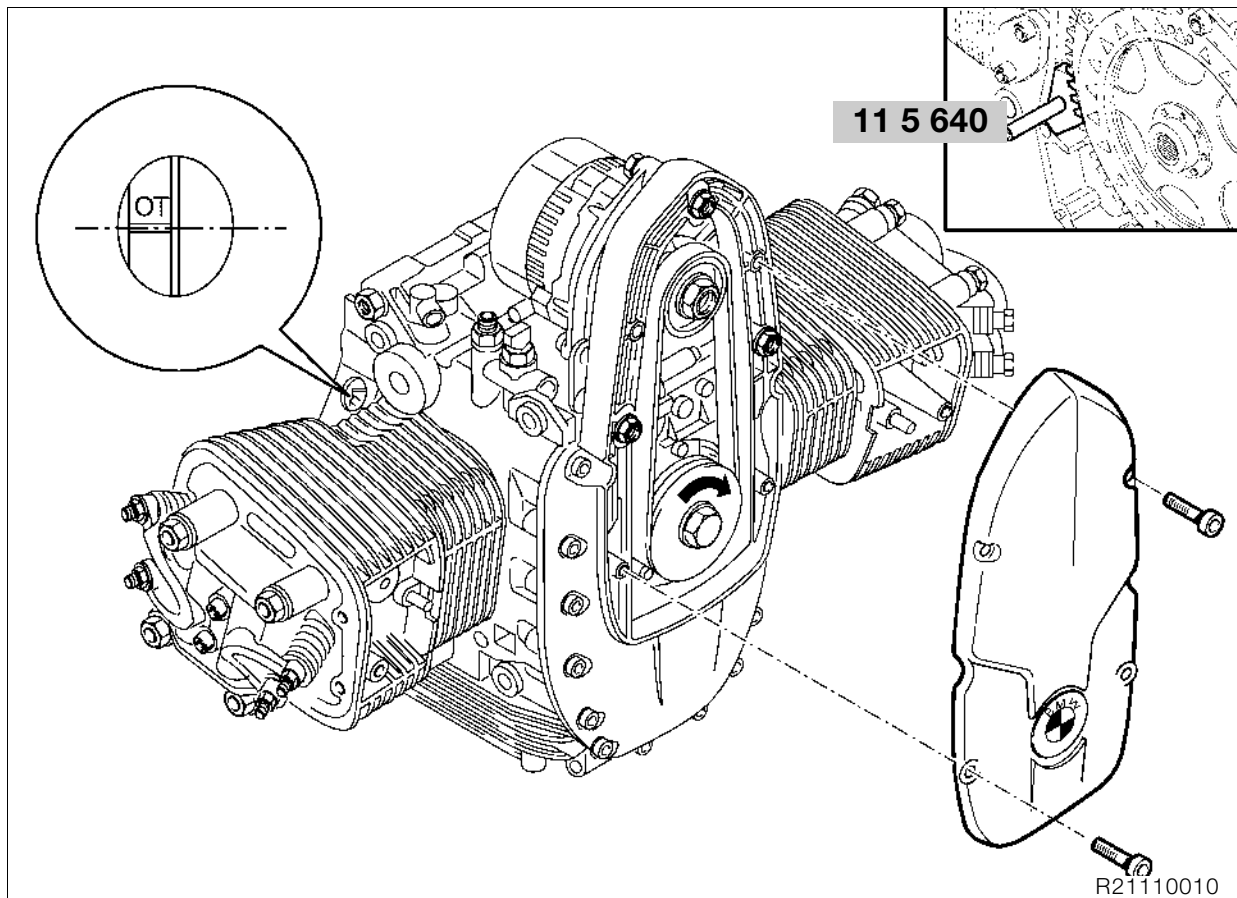

Locking the engine at TDC

- Remove front cover.
- Turn the belt pulley to bring the piston to firing TDC.

Firing TDC

1. TDC mark is visible, and
 2. The inlet and exhaust valves of the cylinder in question are closed.
- Install locking device, **BMW No. 11 5 640**, to lock clutch housing.

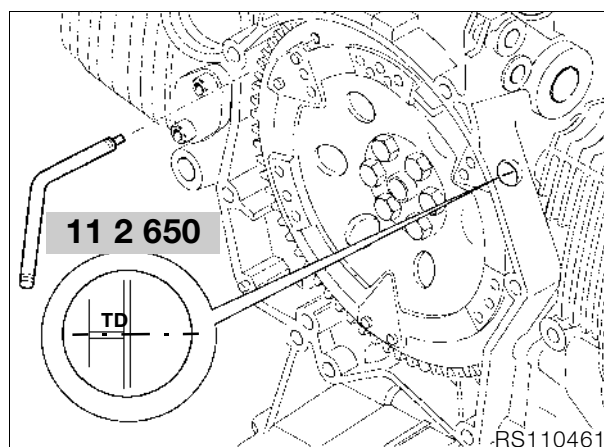

Note:

The engine can be locked at TDC by inserting locating pin, **BMW No. 11 2 650**, through the hole in the clutch housing and the engine block.

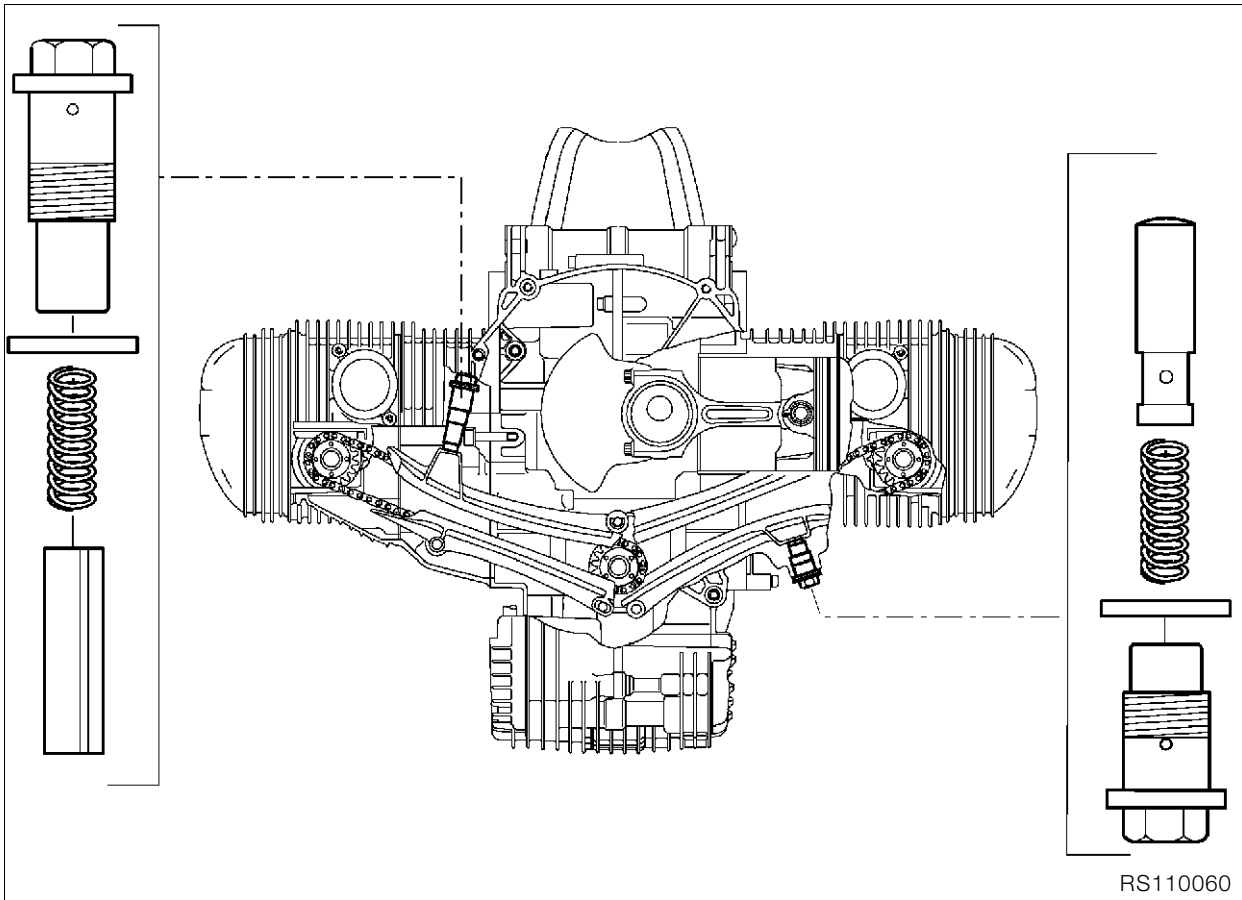

Removing and installing chain tensioner



Caution:

Do not mix up the chain tensioner pistons. When installing, fit a new seal.

Work instructions, timing-chain tensioner

Removing:

- Remove timing chain tensioner, then remove camshaft sprocket from camshaft.

Installing:

- First install camshaft sprocket, then timing chain tensioner.



Caution:

Failure to observe this sequence can cause the chain tensioner piston on the left to drop into the timing-chain chamber.



Tightening torque:

Chain tensioner 32 Nm

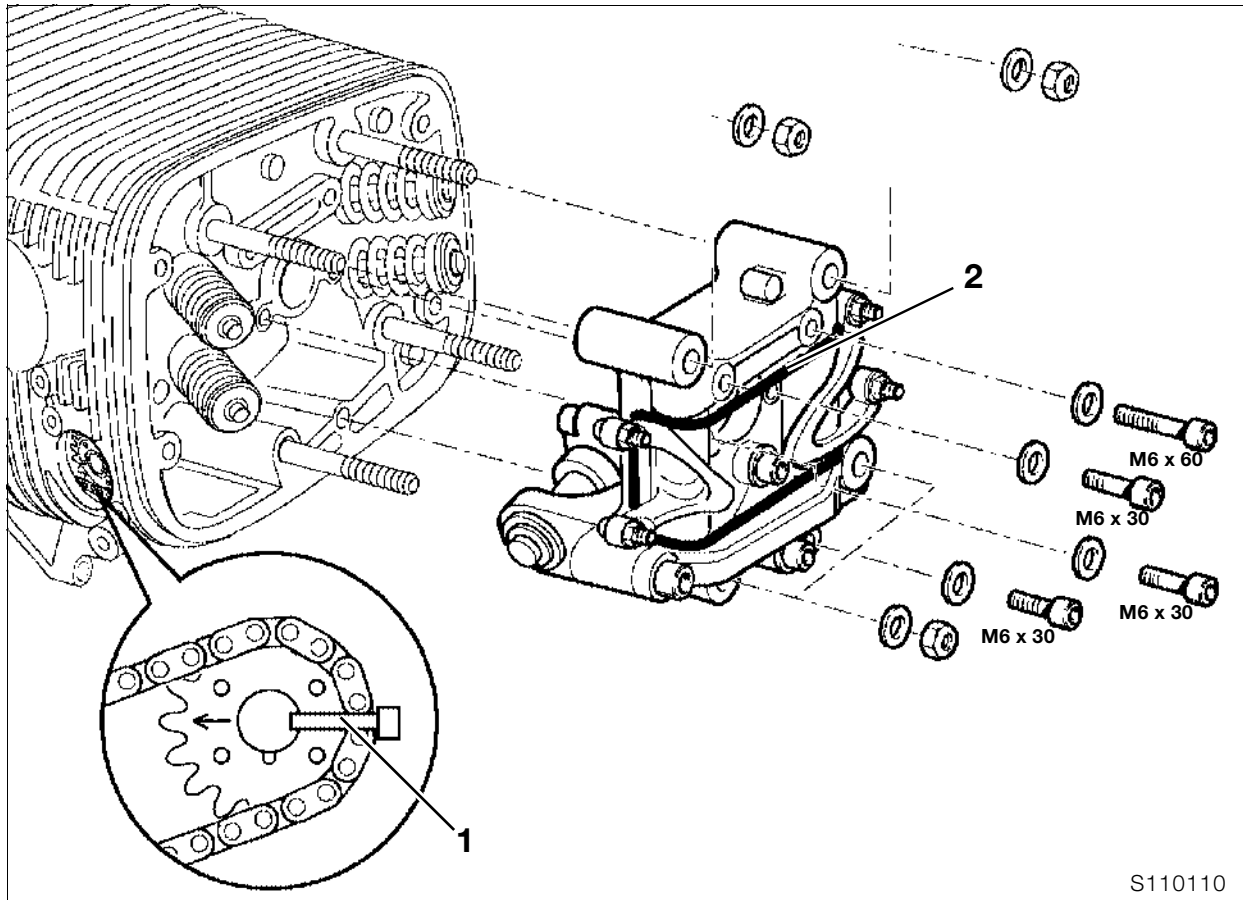

S110110

Remove valve gear carrier

- Remove valve gear carrier.
- Secure rockers with a rubber band (2).



Note:

If no work is to be carried out on the valve gear carrier, remove it together with the cylinder head.

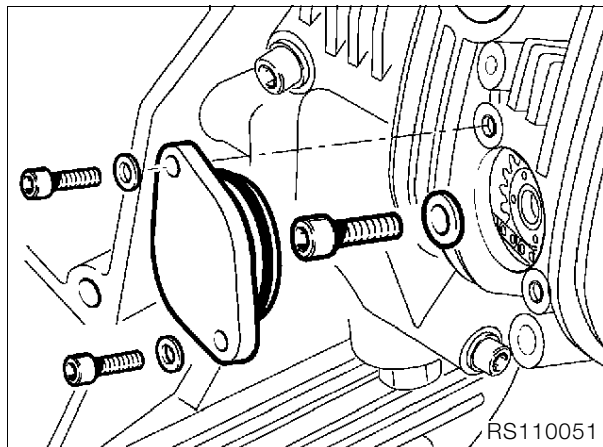

RS110051

- Remove camshaft sprocket cover.
- Remove/pull off camshaft sprocket.



Note:

If the camshaft sprocket (1) is not removed after loosening, it must be held firmly and prevented from falling into the engine block (e.g. with a cable strap).

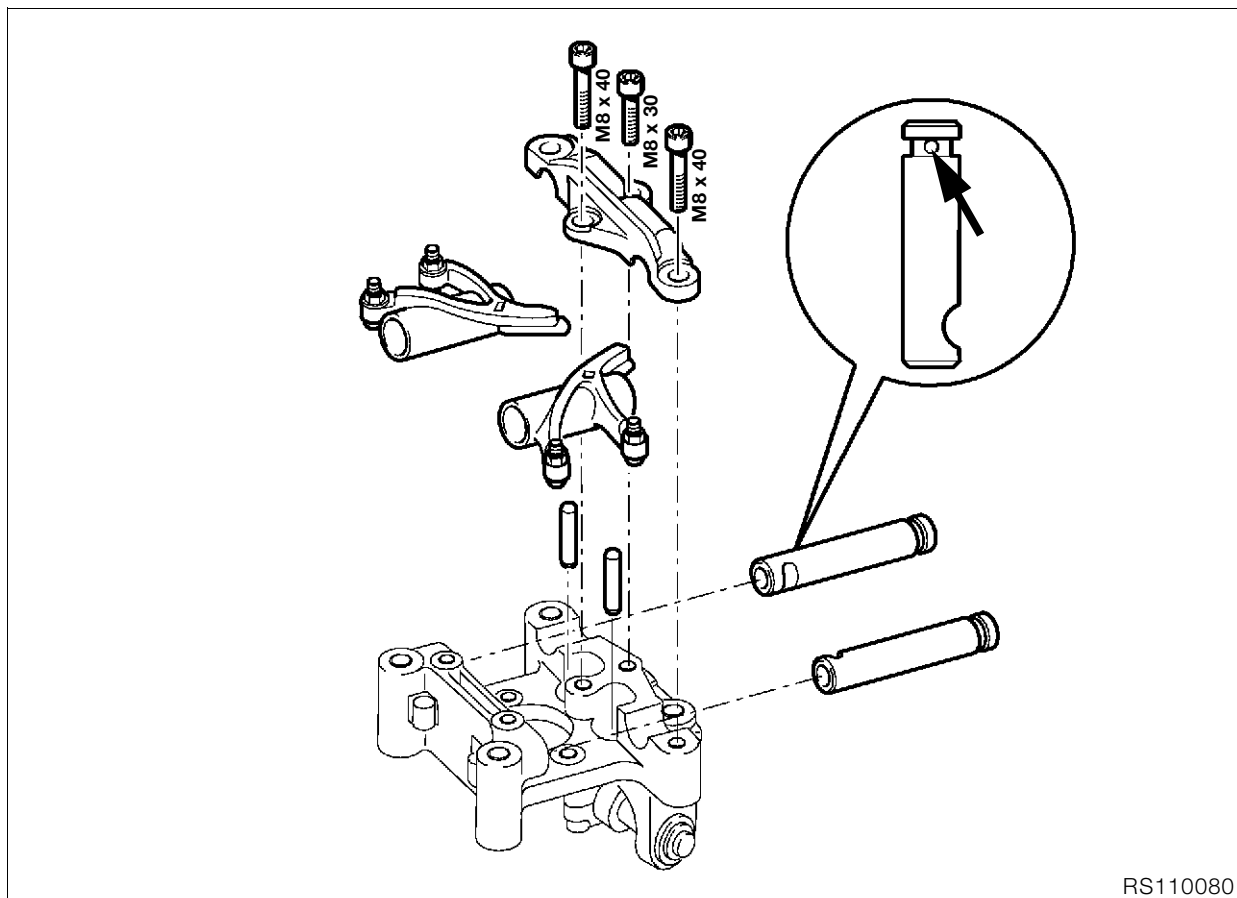
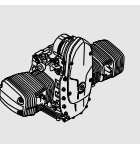

RS110080

Disassembling/assembling valve gear carrier

- Remove bearing cap.
- Insert a suitable pin into the bore (arrow) of the rocker shaft, and turn the shaft back and forth to remove it from its bearing.
- Remove pushrods.

⚠ Caution:

Do not mix up the rocker shafts and pushrods.

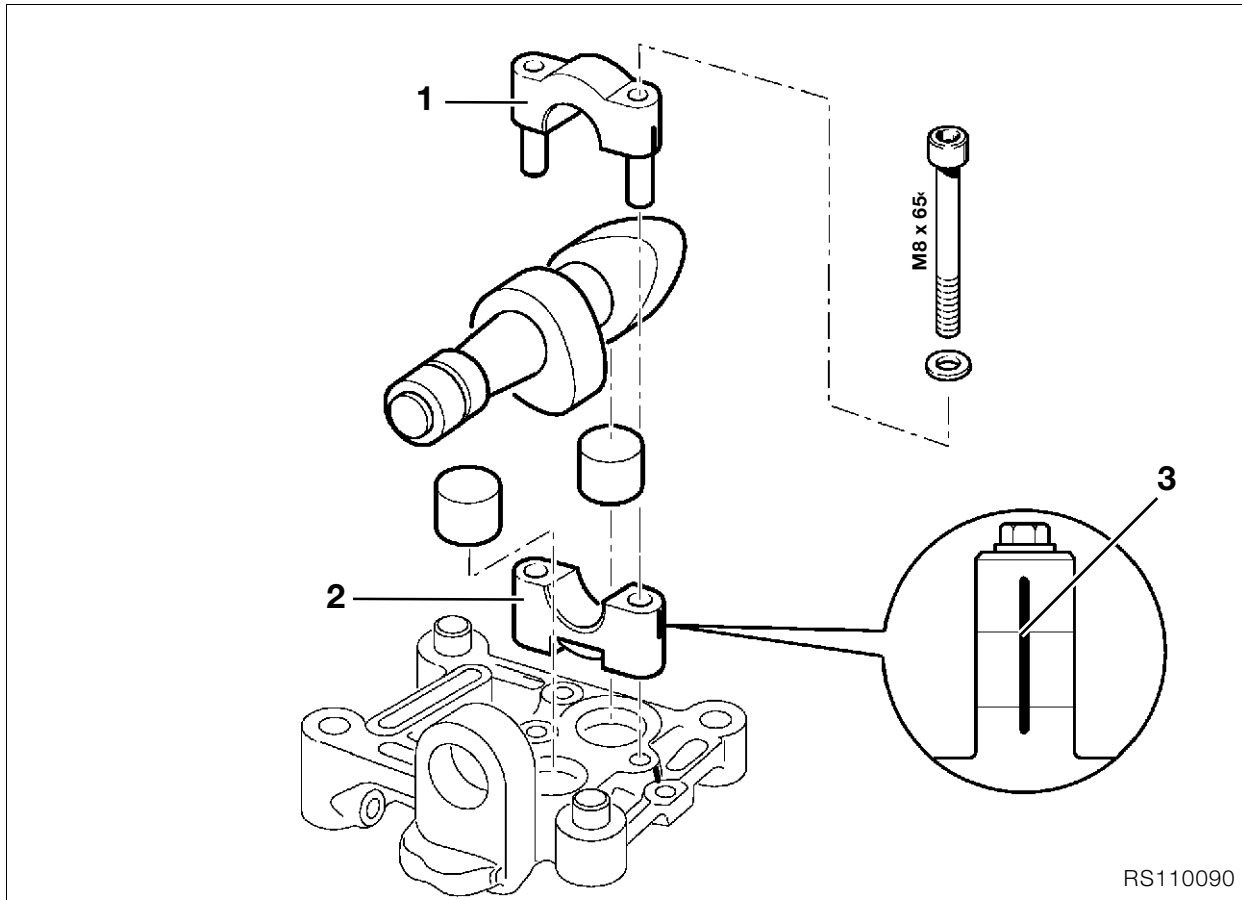

RS110090

- Remove camshaft bearing cap (1).
- Remove camshaft and bearing (2).
- Remove bucket-type tappets.

⚠ Caution:
Do not mix up the bucket-type tappets.

- Assembly is the reverse of the disassembly procedure.

⚠ Caution:
Note direction of installation (3) for camshaft bearing cap. Rocker shaft recess must be aligned with the bores.

📄 Note:
Locate pushrods in ball cups of rockers and hold the rockers together with a rubber band to secure the pushrods in position.

🔧 Tightening torque:
M 8 screw, rocker shaft bearing cap 18 Nm
M 8 screw, camshaft bearing cap 15 Nm

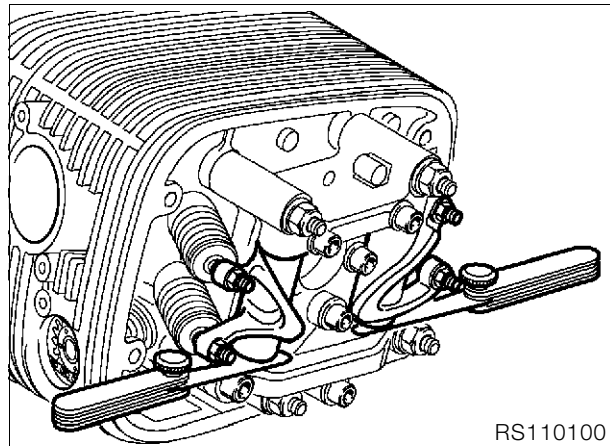

RS110100

- Adjust the holder for minimum end float.

End float of rockers:

min.	0.05 mm (0.002 in)
max.	0.40 mm (0.016 in)

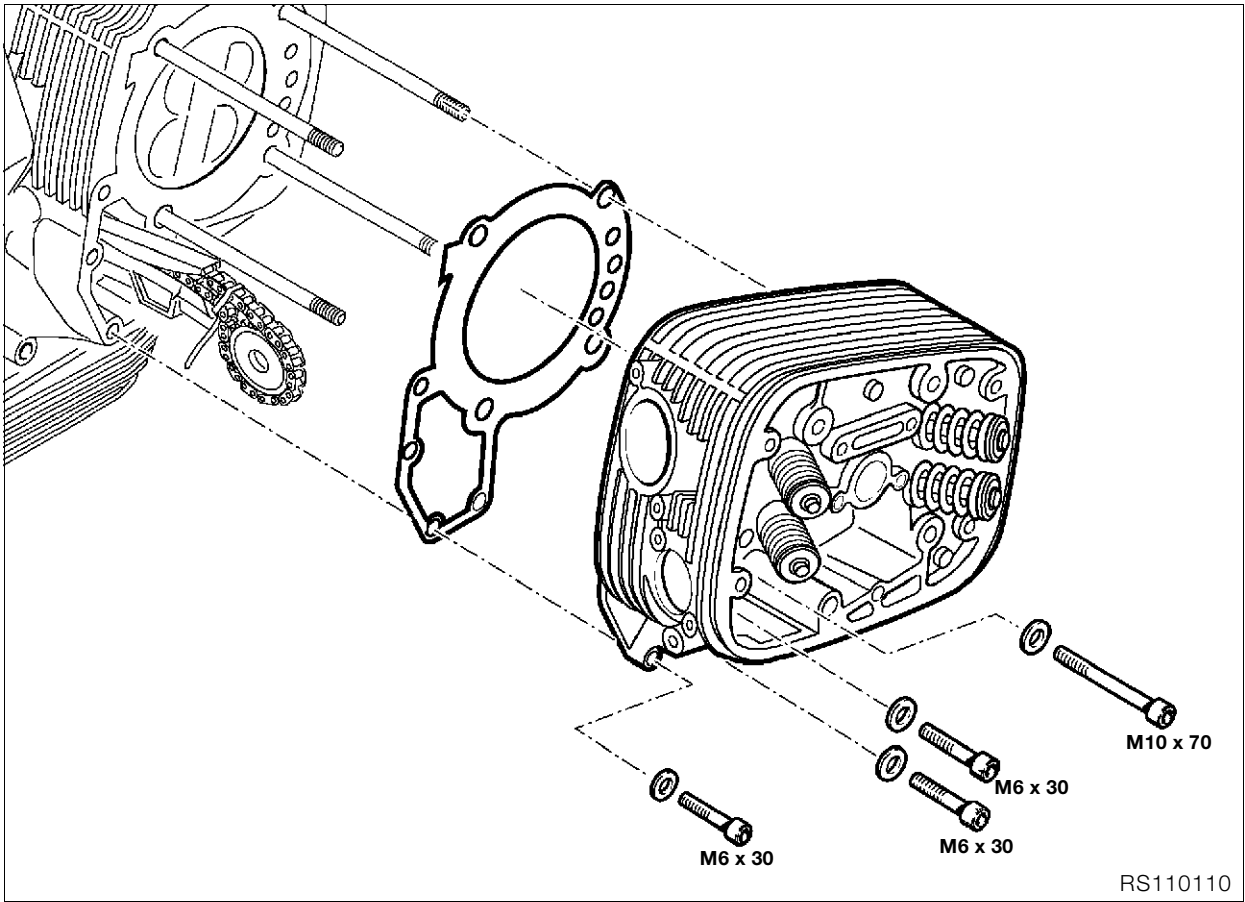

Removing cylinder head

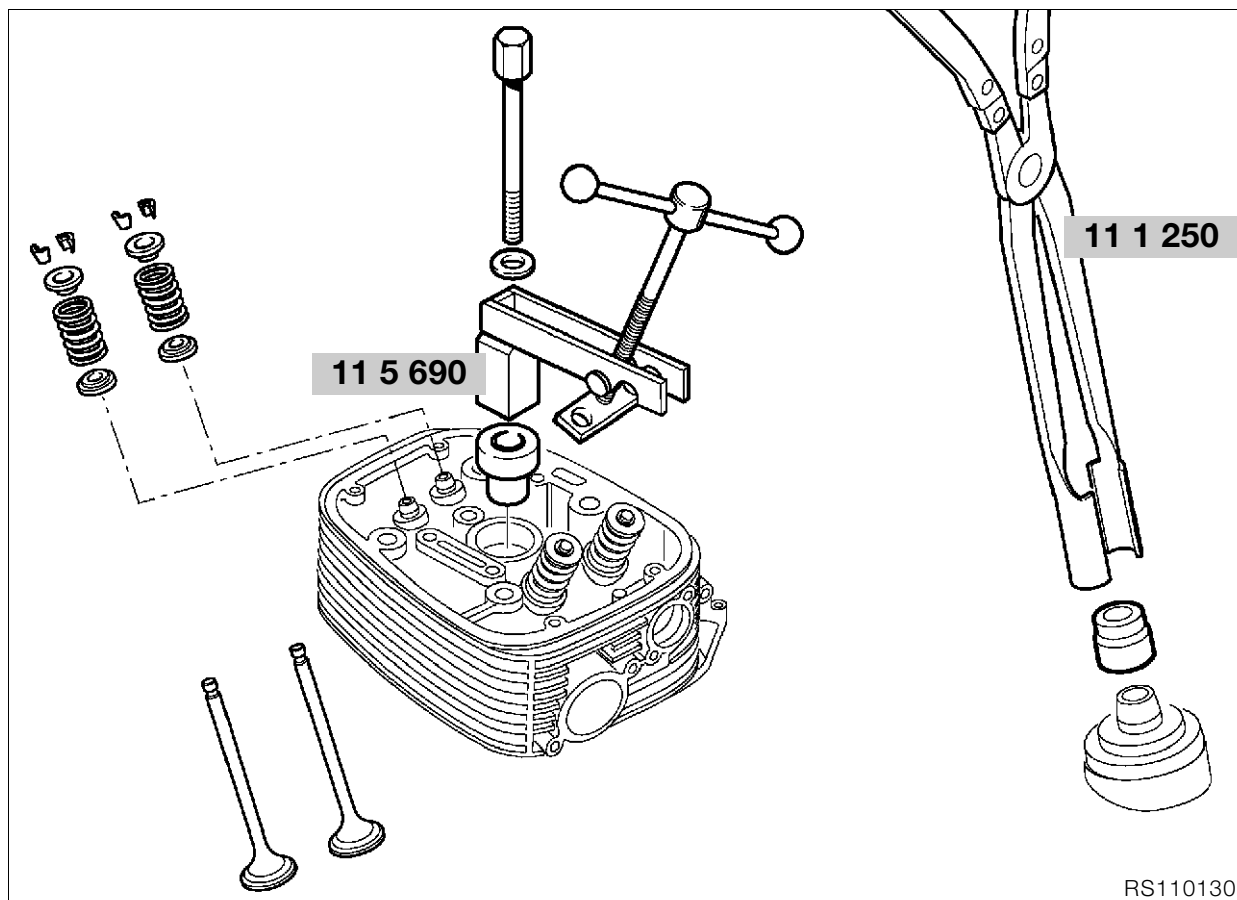

Disassembling, checking, repairing and reassembling cylinder head

Removing and installing valves



Caution:

Do not scratch sealing face on cylinder head. Place the head on a clean, non-scratching surface.

- Mount valve spring compressor, **BMW No. 11 5 690**, onto cylinder head.
- Compress the valve springs.
- Gently tap valve head to release collets from spring retainer.
- Remove valve collets.
- Relieve tension on valve springs.
- Remove top and bottom spring retainers, valve springs and valves.

Removing valve stem seals

- Pull off valve stem seal with pliers, **BMW No. 11 1 250**.



Note:

If a valve is removed, the valve stem seal must be replaced.

Checking valves for wear

- Remove combustion residue from valves.
- Check valve dimensions.

⇒ see Technical Data

Remachining valve seat

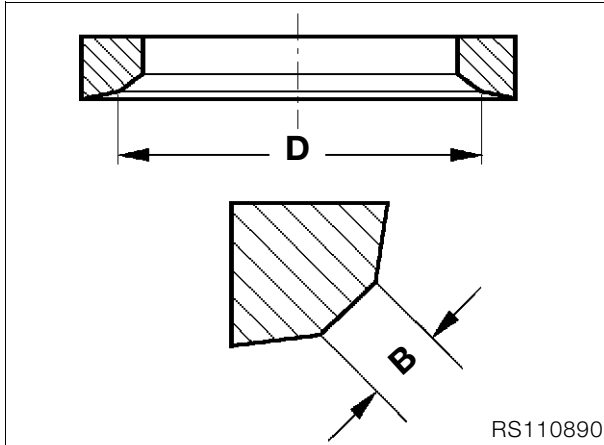

Caution:

Width (B) and diameter (D) must always be maintained if valve seat is machined.

⇒ see Technical Data

Checking and repairing cylinder head

- Remove combustion residues from combustion chamber.
- Check sealing face for damage/distortion, and skim flat if necessary.

Skimming sealing face: max. 0.2 mm (0.008 in) metal removal

Checking valve guide for wear

- Check valve guide bore.

⇒ see Technical Data

Replacing valve guides

- Heat cylinder head slowly and uniformly to 200 °C (392 °F) in a suitable oven.



Caution:

Wear protective gloves when handling heated parts.

- Drive out valve guides with 5 mm (0.1969 in) dia. drift, **BMW No. 11 5 674**, from the combustion chamber side.
- Allow cylinder head to cool down to room temperature (approx. 20 °C/68 °F).
- Examine valve guide bore for:
 - wear,
 - widening taper and
 - correct dimensions in H7 tolerance range (12.500...12.518 mm/0.4921...0.4928 in).



Note:

Valve guides are press-fitted in the cylinder head with an interference fit of 0.015...0.044 mm (0.0006...0.0017 in).

If valve guide bore is undamaged and dimensions are within correct 12.5 H7 tolerance range:

- Use original 12.5 U6 (12.533...12.544 mm/0.4934...0.4939 in) valve guide.
- Measure valve guides with micrometer.

If valve guide bore is undamaged but slightly larger than the 12.5 H7 tolerance range:

- Use replacement valve guide 12.550...12.561 mm (0.4941...0.4945 in).

If valve guide bore is damaged or not to correct dimensions in 12.5 H7 tolerance range:

- Use an oversize 12.7 U6 (12.733...12.744 mm/0.5013...0.5017 in) valve guide.

Repair method 1 – ream out the bore

(if bore is damaged or not to correct dimensions)

- Determine actual diameter of valve guide using micrometer.
- Ream bore with Ø12.7 H7 mm (12.700...12.718 mm/0.5000...0.5007 in) reamer.

Repair method 2 – turn the valve guide on a lathe (only if bore is undamaged)

- Measure bore with internal measuring tool.
- Calculate the nominal diameter of the valve guide:

Required diameter of valve guide = bore dia. + interference-fit value (0.015...0.044 mm/0.0006...0.0017 in).

- Use an oversize 12.7 U6 (12.733...12.744 mm/0.5013...0.5017 in) valve guide.
- Machine oversize valve guide to required diameter.

- Slowly heat cylinder head to 200 °C (392 °F) in a suitable oven.
- Immerse valve guide in liquid grinding talc.
- Chill valve guide with dry ice.



Caution:

Immediately before pressing in, the temperature must be –40 °C (–40 °F).

- Place heated cylinder head flat on workbench or a similar surface.
- Mount the chilled valve guide on Ø 5 mm (0.1969 in) drift, **BMW No. 11 5 673**.
- Drive valve guides into cylinder head with no delay.
- Allow cylinder head to cool down to room temperature, approx. 20 °C (68 °F).
- Inspect bores of valve guides.



Note:

Valve guides for repair purposes are produced with an internal diameter of 5.01 mm (0.1972 in) H7. In most cases, the bore is within the 5.00 mm (0.1969 in) H7 tolerance range after pressing in. If the bore is too narrow, ream it out to size.

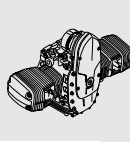

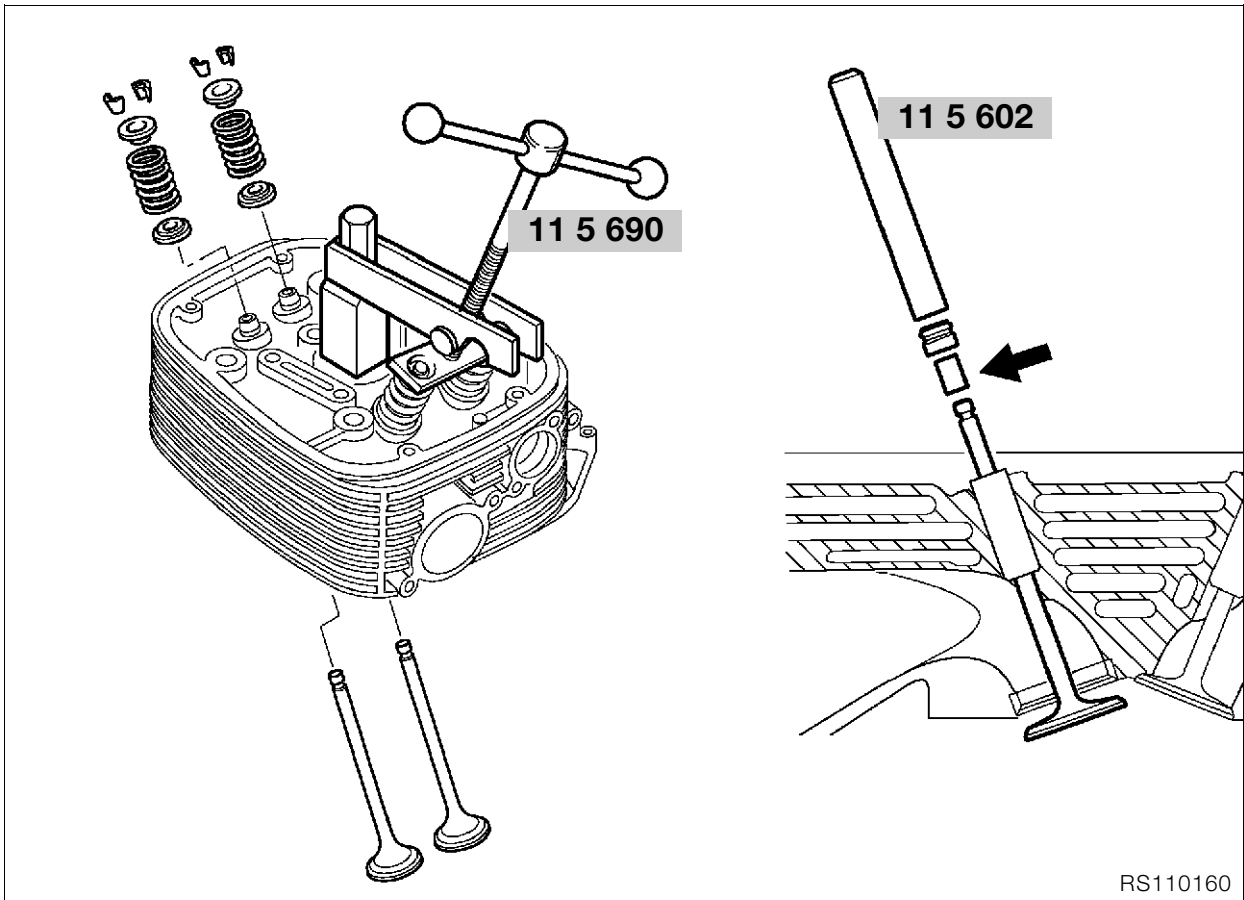

RS110160

Installing valve and valve stem seal



Note:

If a valve was removed, the valve stem seal must be replaced.

- Oil the stem when installing the valve.
- Shrink a short length of tube (arrow) on to the end of the valve stem.
- Install the valve stem seal with a 5 mm (0.1969 in) dia. drift, **BMW No. 11 5 602**.



Caution:

Remove the shrink-fit tube.

- Install lower spring retainer, valve spring and upper spring retainer.
- Compress the valve springs with the valve spring compressor, **BMW No. 11 5 690**.



Note:

Apply grease to valve collets (to facilitate installation) and install.



Caution:

Make sure that valve collets are correctly seated in the valve stem grooves.

- Relieve tension on valve springs.
- Check valves for leakage (blow-by).

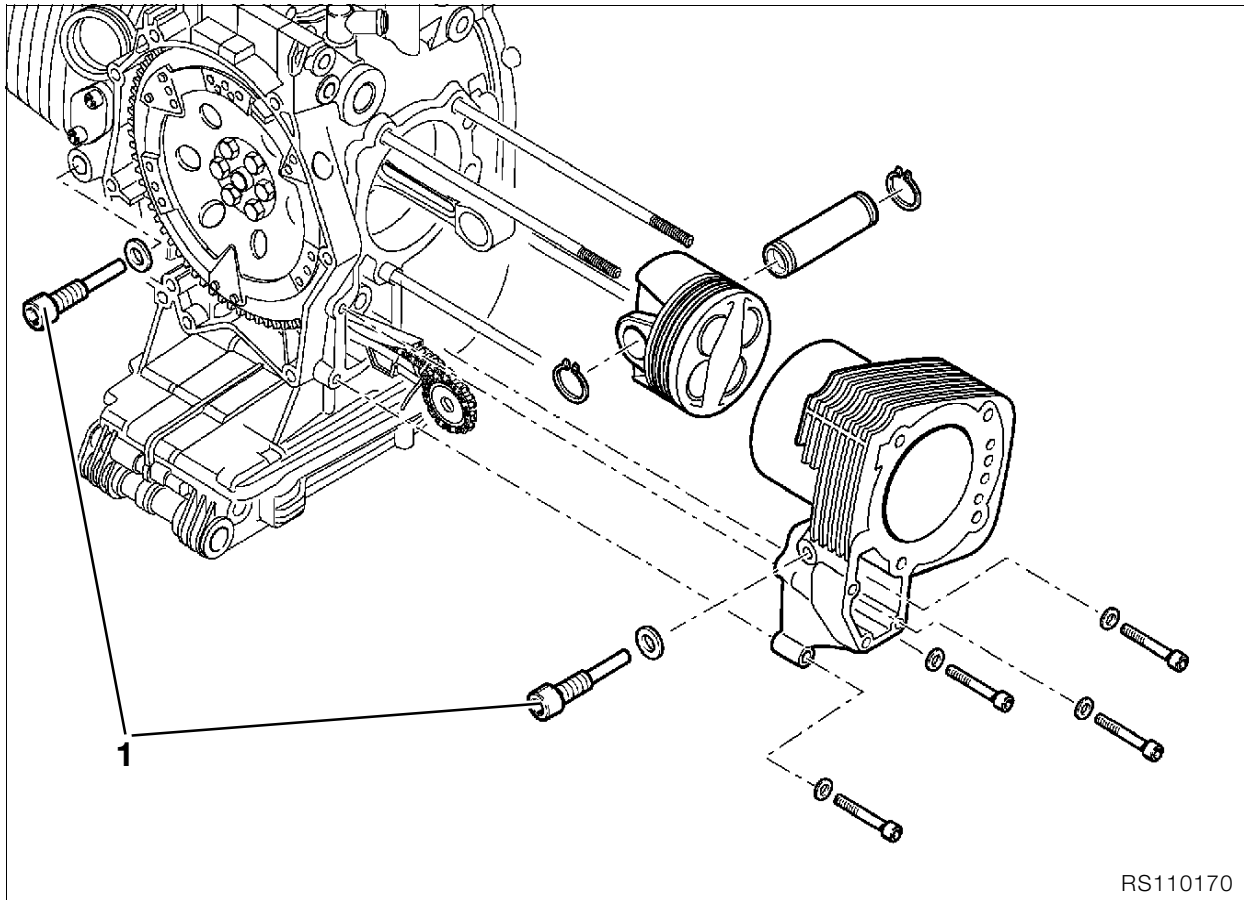

Removing cylinder

- Remove guide rail bearing screws (1).
- Remove cylinder retaining screws, and remove cylinder.

Caution:

When removing cylinder, make sure that the piston does not strike the engine block.

Removing and disassembling piston

- Remove both retaining rings from piston pin.
- Press out piston pin by hand.
- Remove piston.
- Carefully remove piston rings with piston ring pliers.
- Remove combustion residues from piston crown and clean piston.

Caution:

Do not mix up pistons, piston pins and piston rings.

Checking pistons and cylinders

Reference temperature for measurements: 20 °C (68 °F)

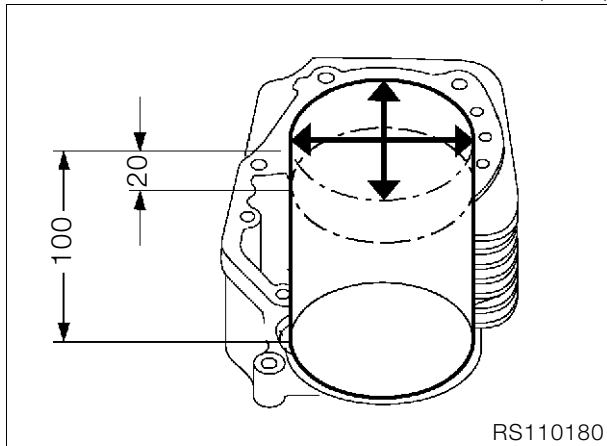

- Measure cylinder bore with internal probe at 20 mm (0.79 in) and 100 mm (3.94 in) from the top in direction of piston pin, and again at a right angle to the first measurement.
- ➡ See Technical Data

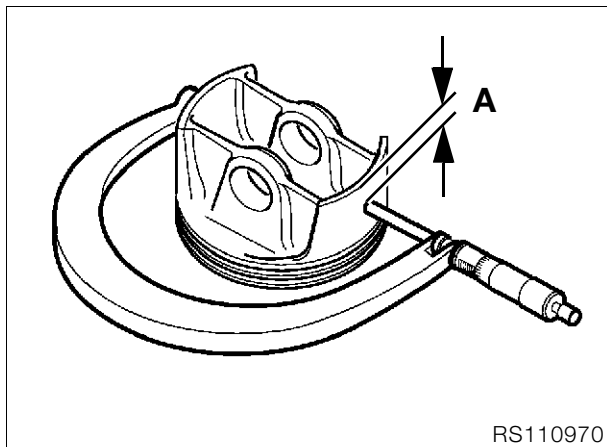

Measuring plane A: 6 mm (0.236 in)

➡ See Technical Data

- Install piston rings in cylinder.

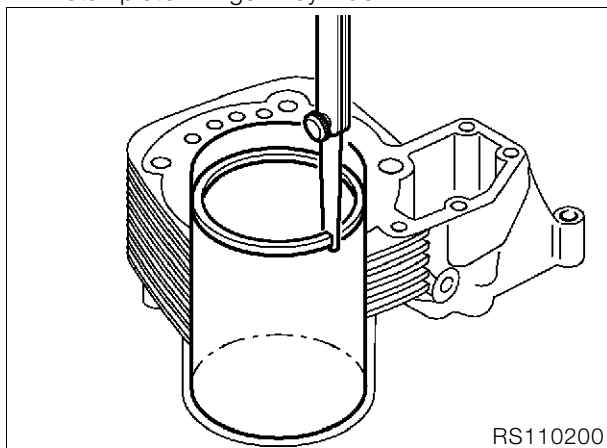

- Measure ring gap using feeler gauge.
- ➡ See Technical Data

Assembling pistons

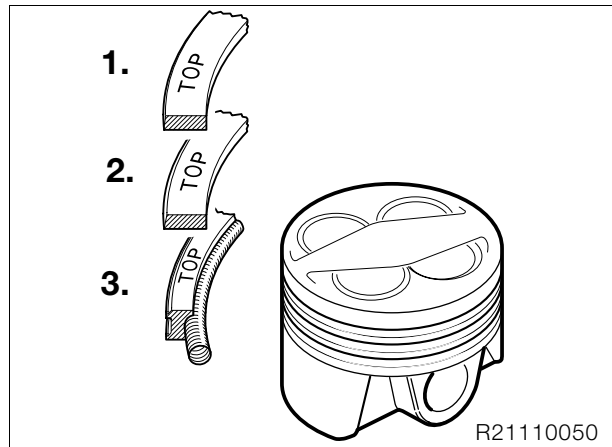

- Carefully fit piston rings to piston in the following sequence, using piston ring pliers:
 - 3rd groove - coiled-spring ring
 - 2nd groove - micro-chamfer ring
 - 1st groove - asymmetric piston ring, oval section
- ➡ See Technical Data



Note:

Make sure that the gap of the spring is offset approximately 180° from the gap of the oil control ring. Install with "TOP" uppermost.

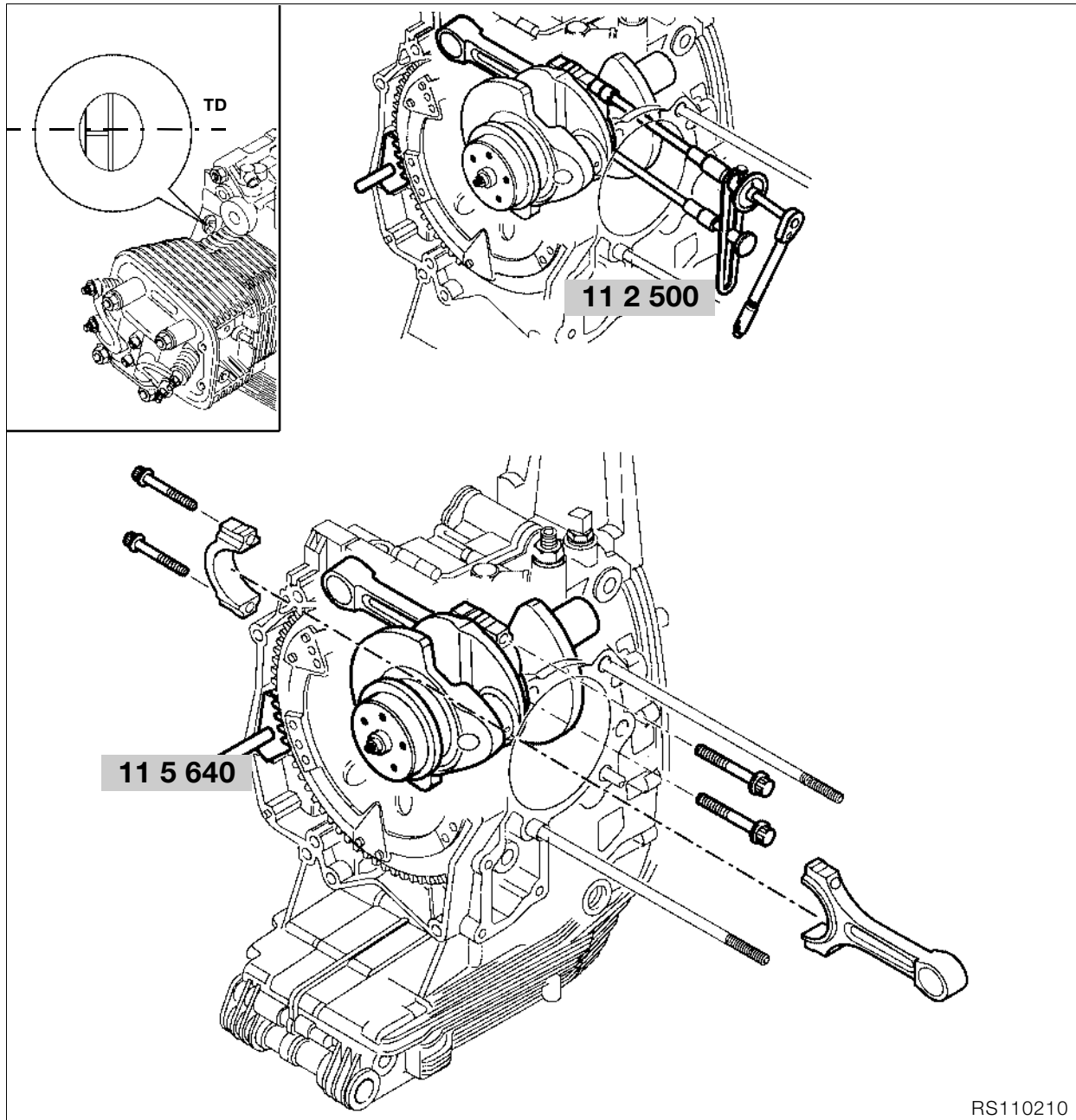

RS110210

Removing and installing conrod

- Turn crankshaft to TDC position.
- Install locking device, **BMW No. 11 5 640**, to lock clutch housing.
- Remove conrods.



Note:

Conrods can also be removed and installed with the crankshaft removed.



Caution:

Do not mix up conrods or bearing shells. Use a felt-tipped pen or similar to mark the installed positions on the conrods.

- Install conrods.



Caution:

Oil the bearings.

- Screw in the big-end bolts by hand and tighten with commercially available angle-of-rotation indicator or tightening angle indicator, **BMW No. 11 2 500**.



Note:

When using tightening angle indicator, **BMW No. 11 2 500**, make sure the extensions are of the same length. Use a 3/8" square-drive socket wrench.



Caution:

Never re-use the big end bolts.



Tightening torque:

Big end bolts oiled
 Closing torque 20 Nm
 Tightening angle..... 80 °

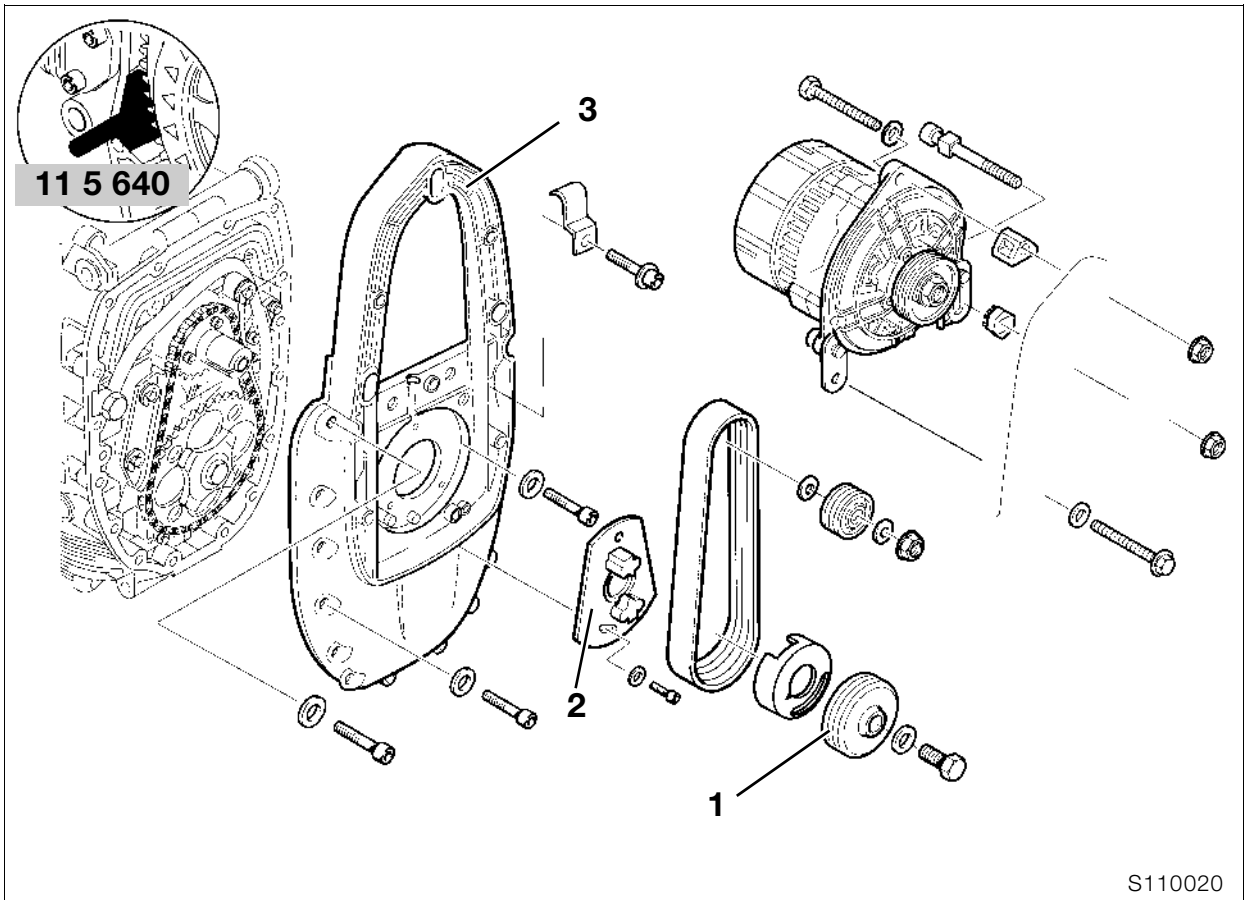

Removing and installing alternator mount cover with engine installed

Replacing radial shaft seal in alternator mount cover

Caution:

Disconnect earth (ground) lead from battery. Insulate earth (ground) lead.

- Remove the horn.
- Remove the oil cooler line.
- Disconnect the Hall sensor.
- Remove the starter motor.
- Remove rear leading link mount.

Removing alternator mount cover

- Remove the alternator.
- Install locking device, **BMW No. 11 5 640**, to lock clutch housing.
- Remove pulley (1).
- Remove magnetic gate (2).

Note:

It is not necessary to remove magnetic gate (2) when removing the alternator mount cover as a unit.

- Remove alternator mount cover (3).

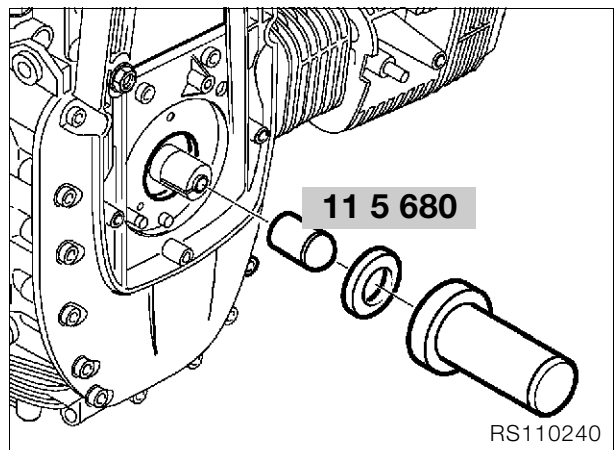

- Carefully lever out radial shaft seal, using a screwdriver.
- Drive in the new radial shaft seal with drift and sliding sleeve, **BMW No. 11 5 680**.

Note:

Slide new radial shaft seal over taper on sliding sleeve, pre-shape and pull off.

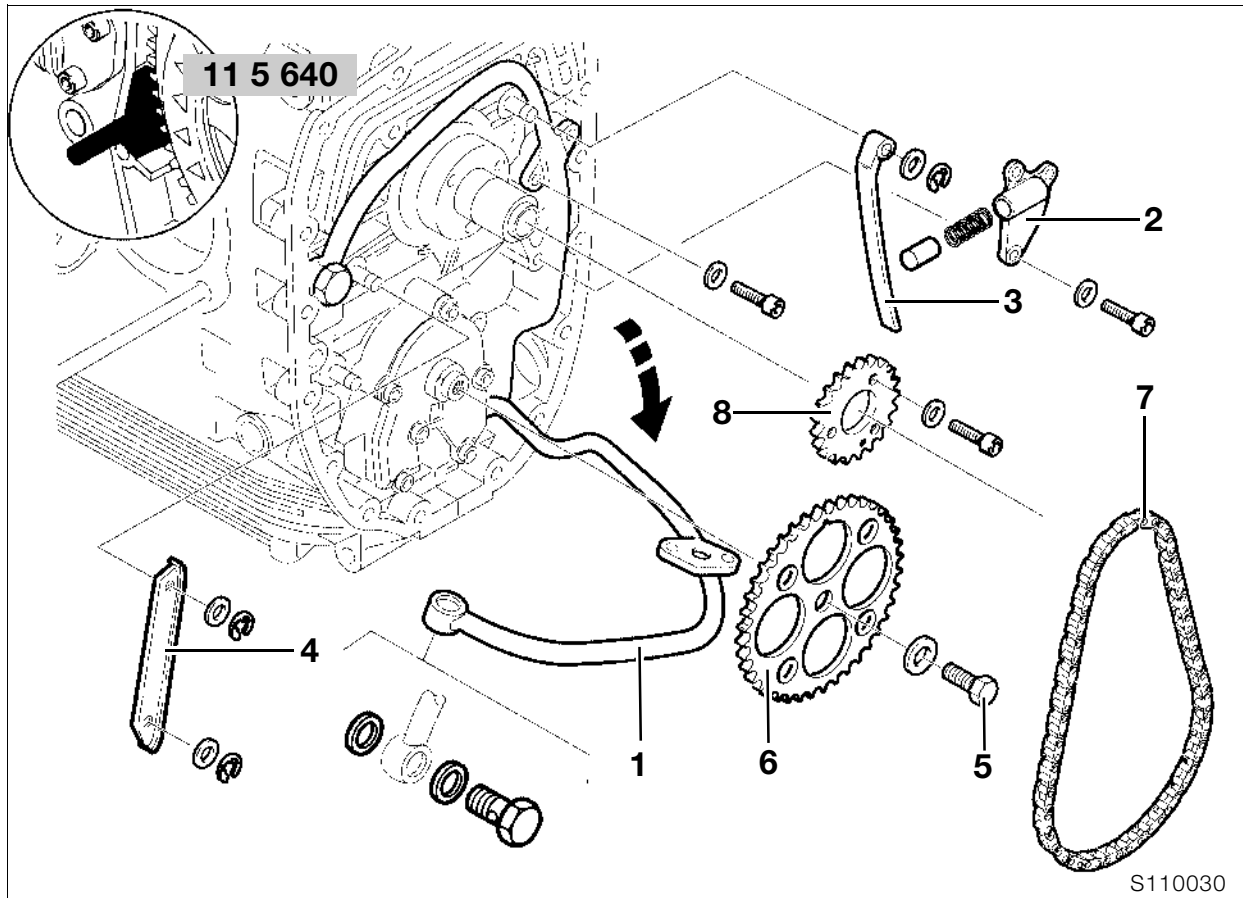

Removing auxiliary shaft drive

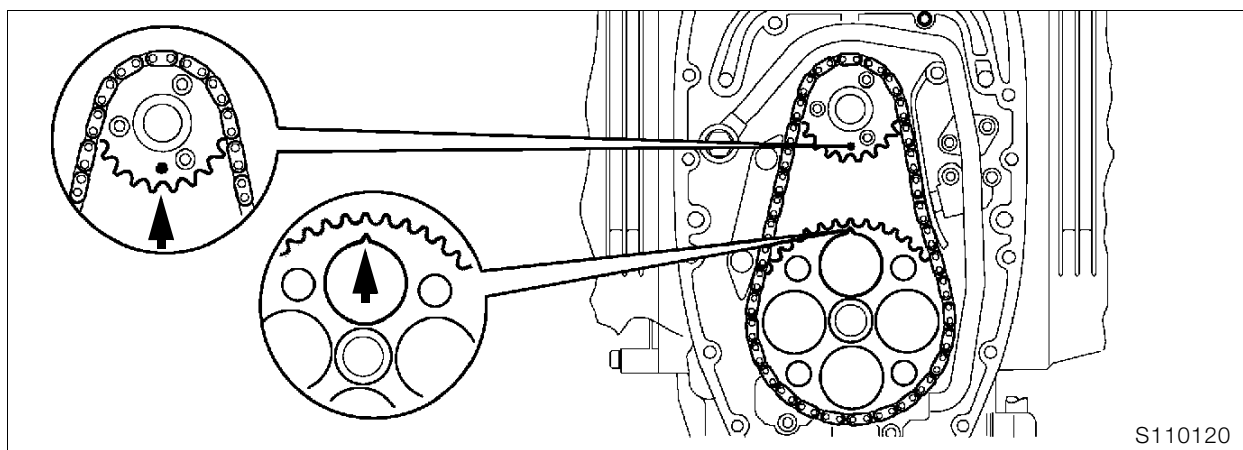

- Align marks (arrows) on timing pinion and chain sprocket.
- Remove banjo bolt of cooling oil pipe (1) and swing the pipe forwards.
- Remove chain tensioner (2).
- Remove chain tensioning rail (3).
- Remove chain guide rail (4).
- Install locking device, **BMW No. 11 5 640**, to lock clutch housing.
- Remove chain sprocket retaining screw (5).
- Remove sprocket (6) and timing chain (7).
- If necessary, remove chain sprocket (8).

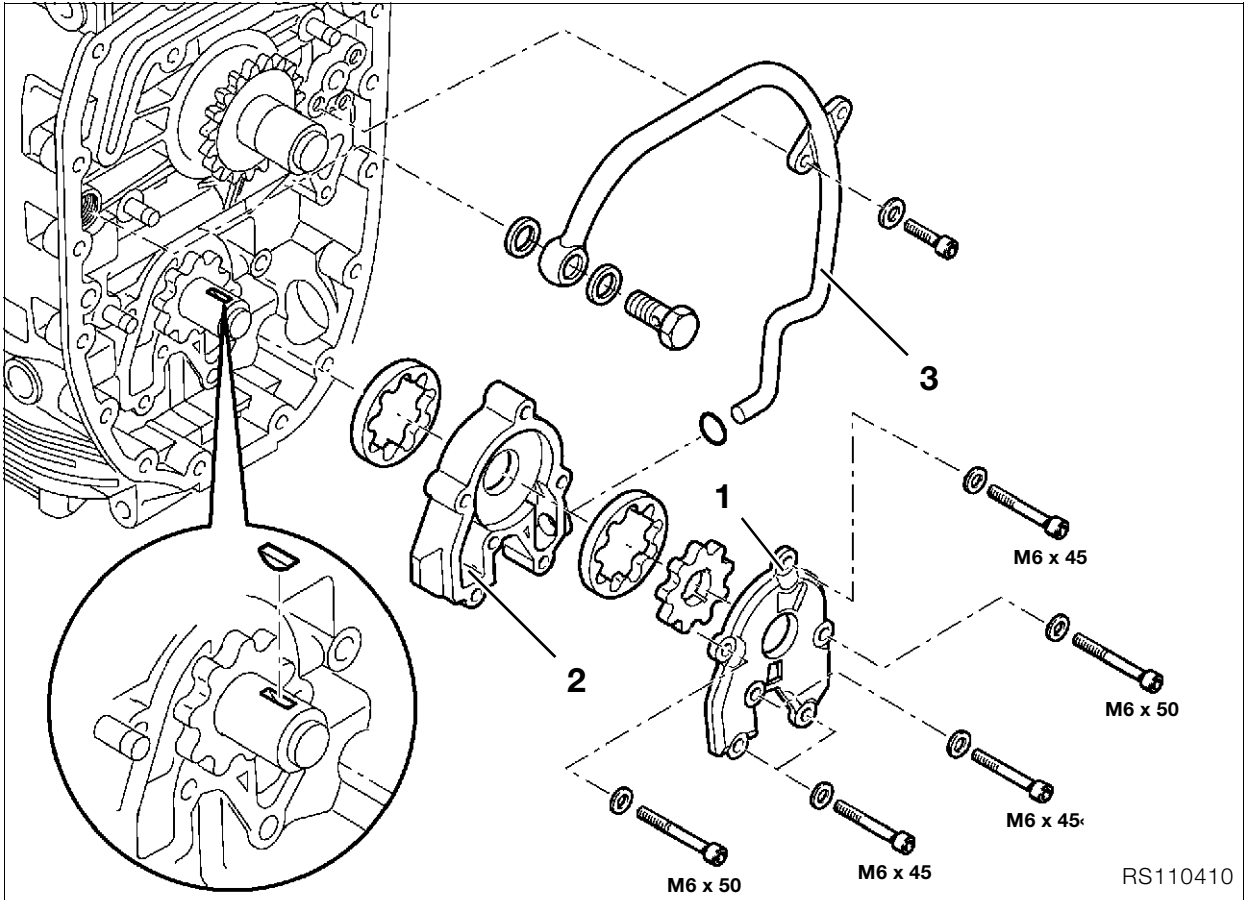

Removing oil pump

- Remove oil pump cover (1).
- Remove complete oil pump (2) together with cooling oil pipe (3), and disassemble.

⚠ Caution:

Check installed positions of parts which have already been run together.

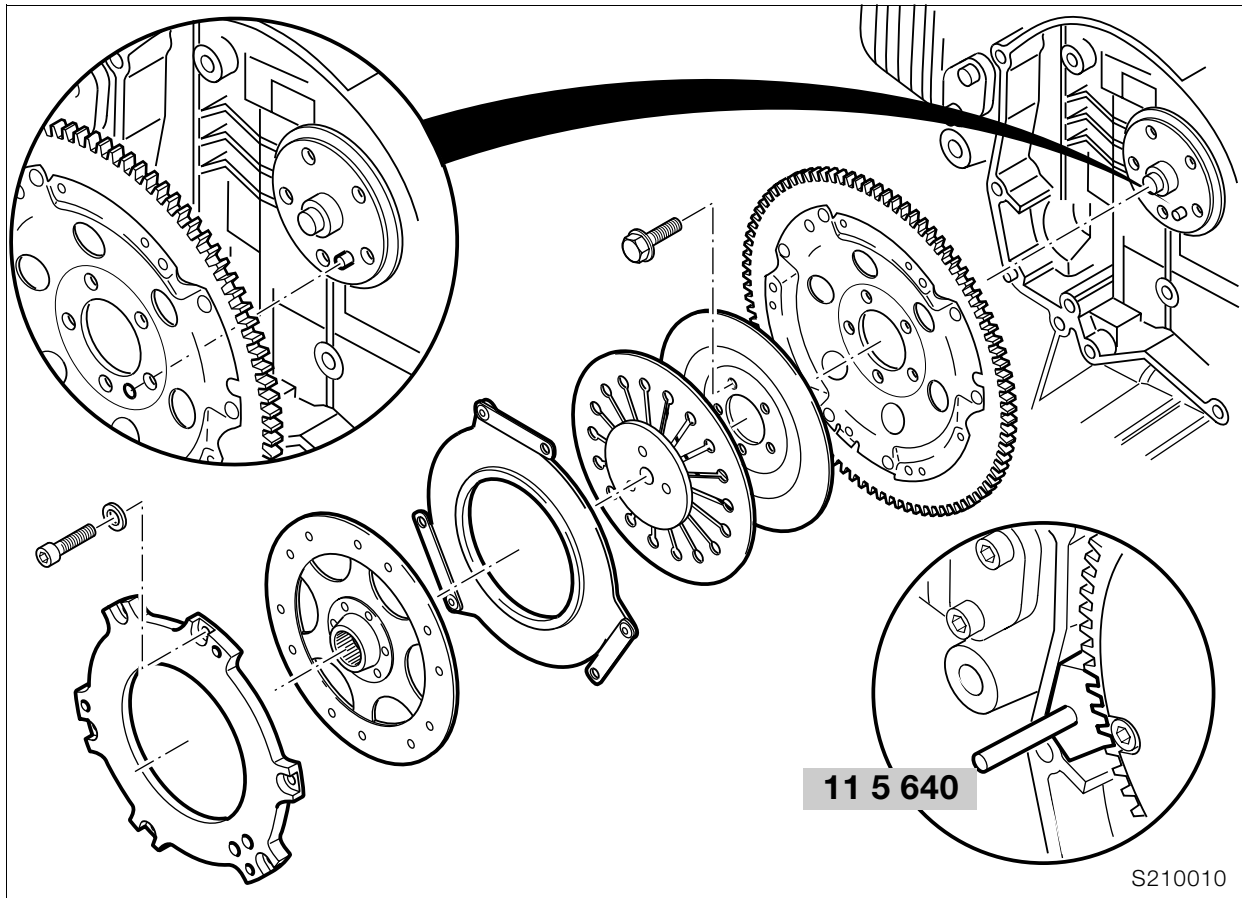

S210010

Removing radial shaft seal from crankshaft with engine installed

- Lock clutch housing with special tool, **BMW No. 11 5 640**.
- Remove the clutch.

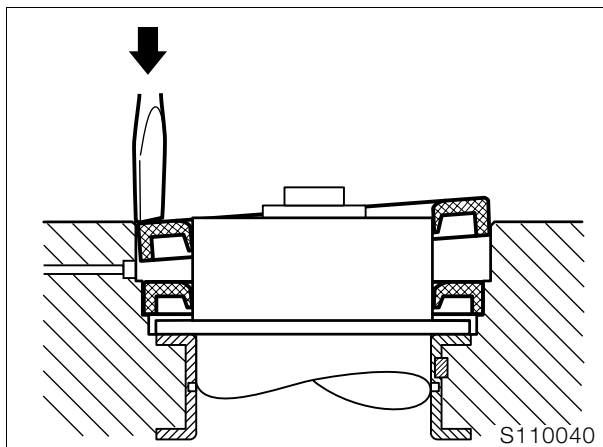

- Carefully lever out radial shaft seal, using a screwdriver.



Caution:

Take care not to damage the sealing faces of crankcase and crankshaft.



Note:

The radial shaft seals can be removed when the crankcase is disassembled.

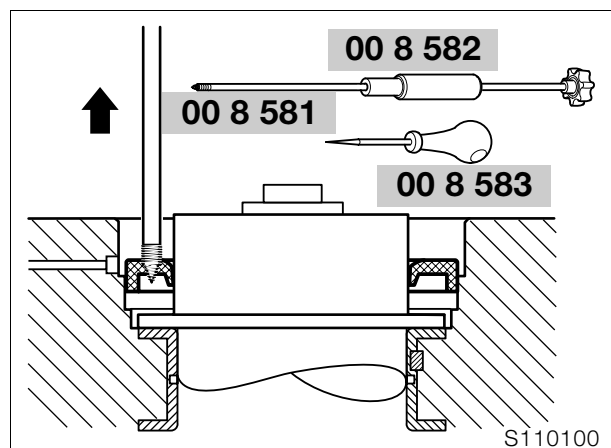

- Using awl, **BMW No. 00 8 583**, carefully punch a hole in the shaft sealing ring.
- Screw the pull rod, **BMW No. 00 8 581**, into the pierced hole and use impact weight, **BMW No. 00 8 582**, to remove the shaft sealing ring.

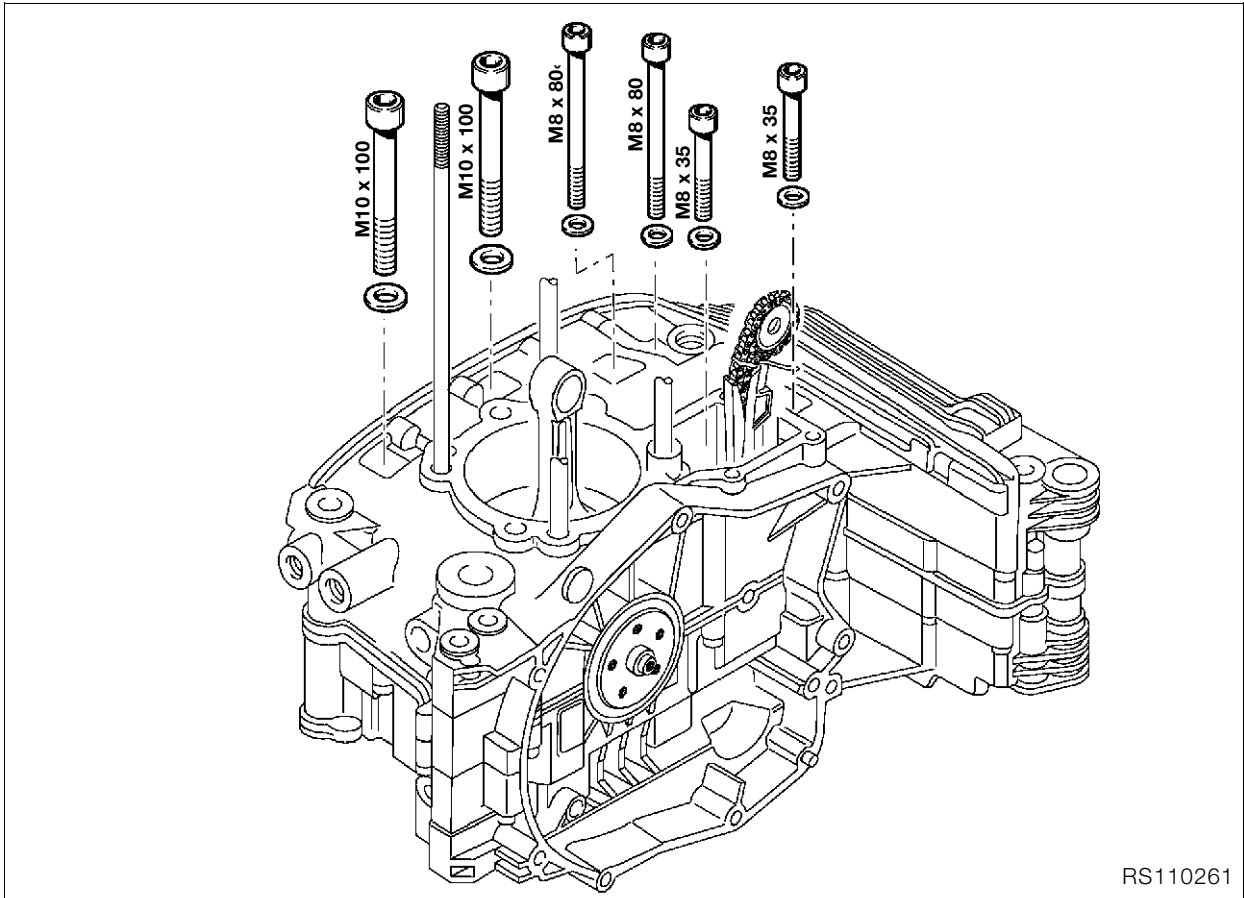
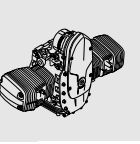

RS110261

Disassembling crankcase

- Turn engine on to its side.
- Remove screws on right side.

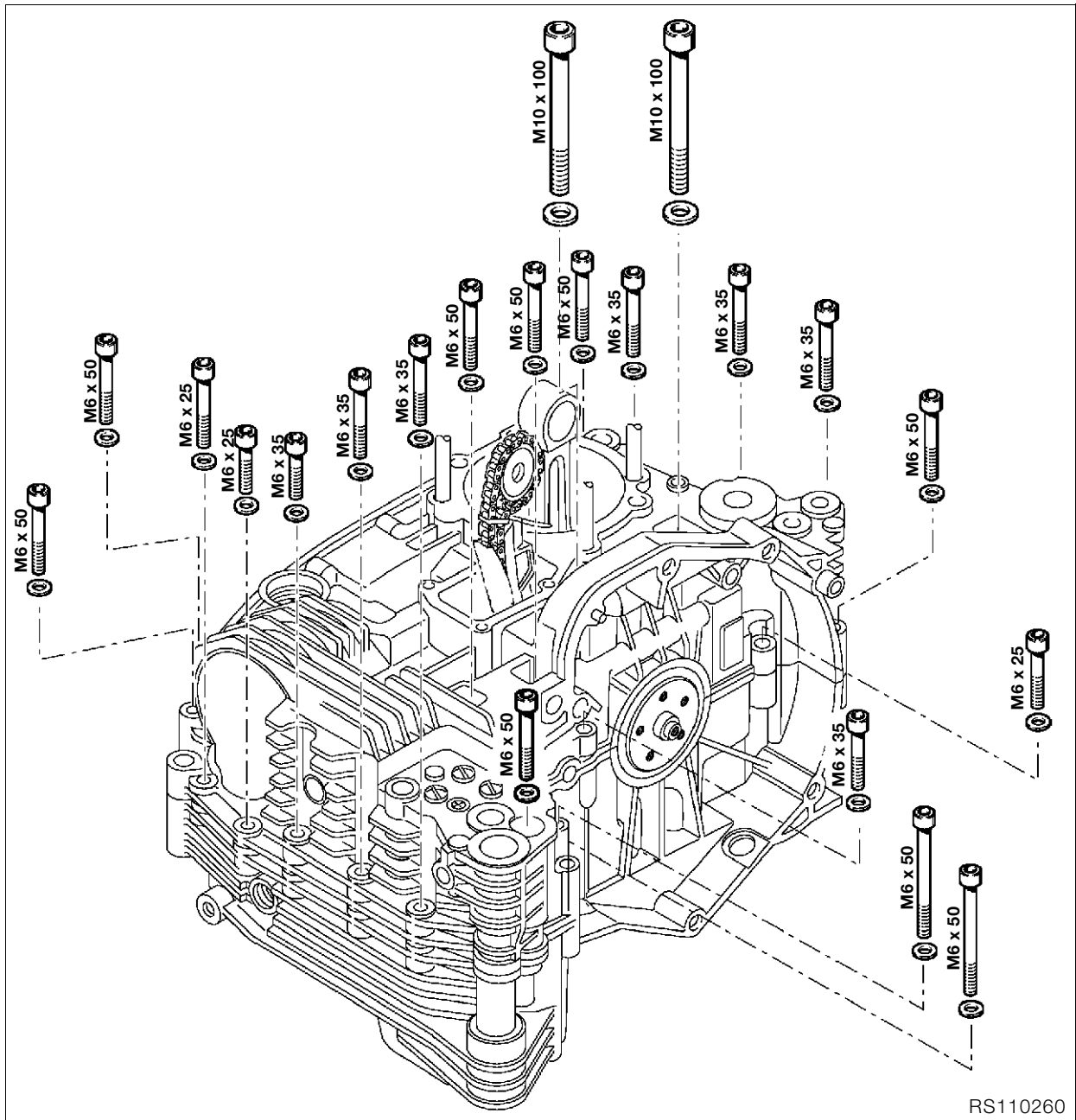

RS110260

- Turn engine on to its side.
- Remove screws on left side.
- Remove upper section of crankcase.

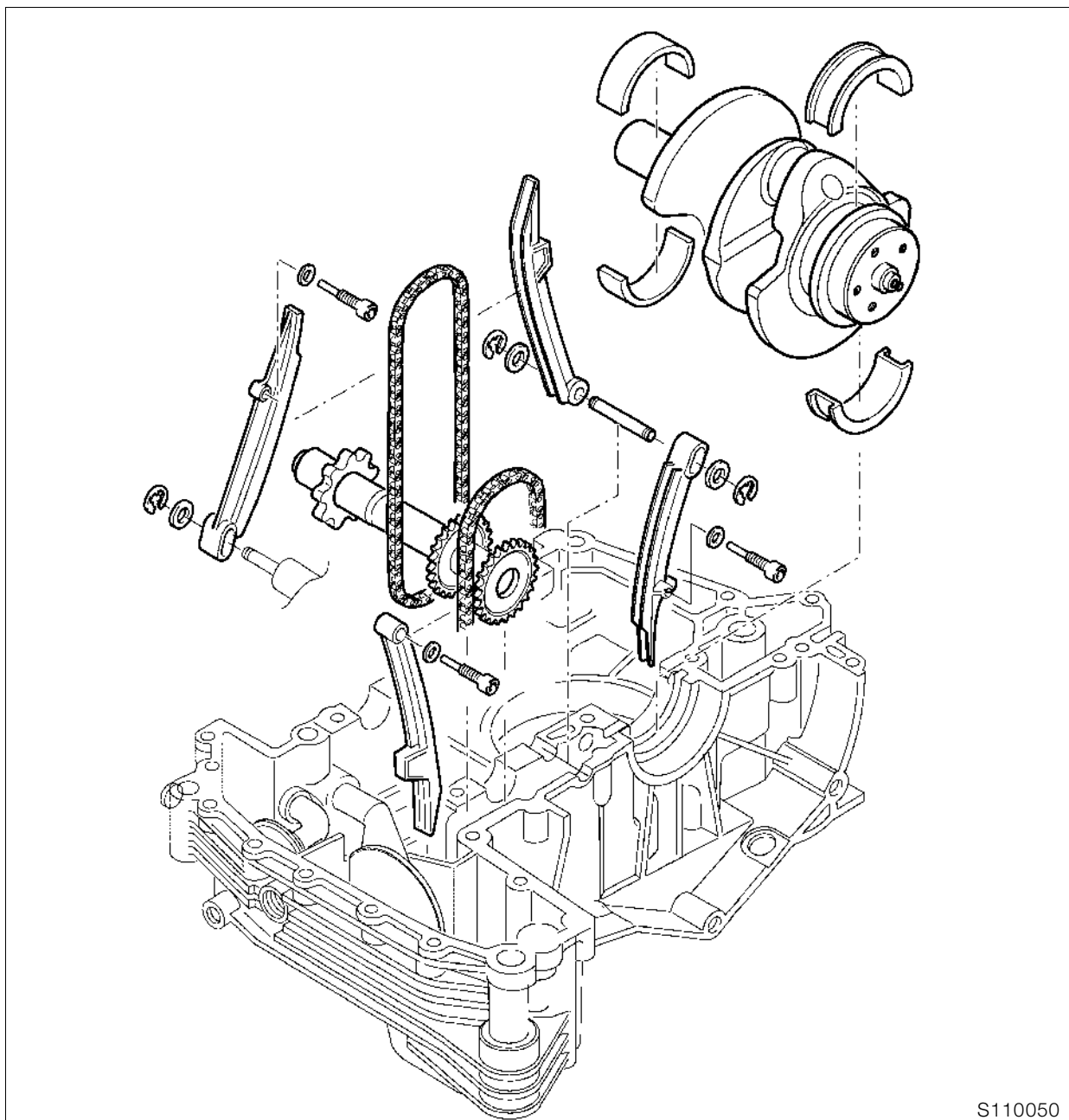
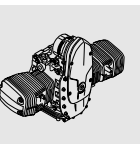

Removing crankshaft, auxiliary shaft and timing chain tensioning and slide rails

Removing and installing oil intake strainers

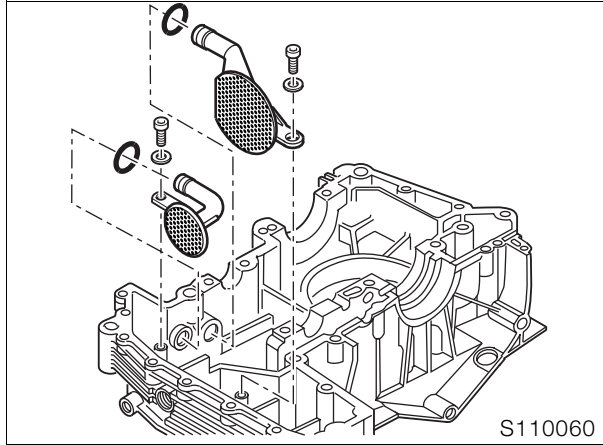

Tightening torque:
M 6 screw 9 Nm

Caution:
Make sure that the O-ring is not omitted, and is installed undamaged.

Replacing oil level sight glass

- Pierce the plastic disc with a large screwdriver and lever out the oil level sight glass.
- Coat the sealing face of the new oil level sight glass with engine oil and drive it in with drift, **BMW No. 00 5 550**.

Removing and installing oil thermostat

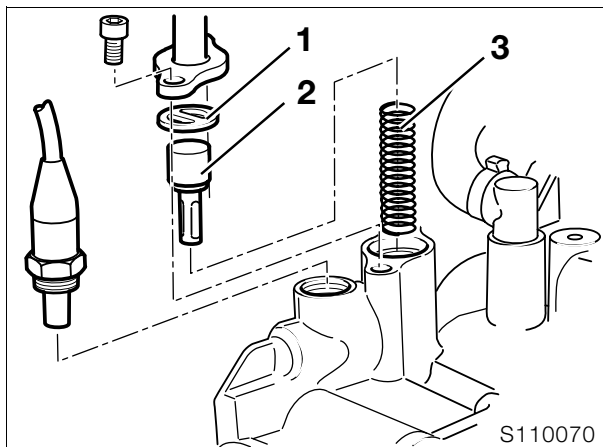

- Remove screws securing oil cooler line to fairing bracket.
- Disconnect oil cooler line from crankcase.
- Remove support plate (1), control element (2) and spring (3).
- Installation is the reverse of the removal procedure.

Tightening torque:
M 6 screw 9 Nm

Removing conrods

- Clamp crankshaft in a vise with protective jaws.
- Remove conrods.

Caution:
Do not mix up the conrods.

Checking conrods

- Check conrod dimensions.
→ See Technical Data

Caution:
Do not attempt to straighten the steel cracked conrods – risk of fracture.

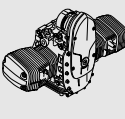

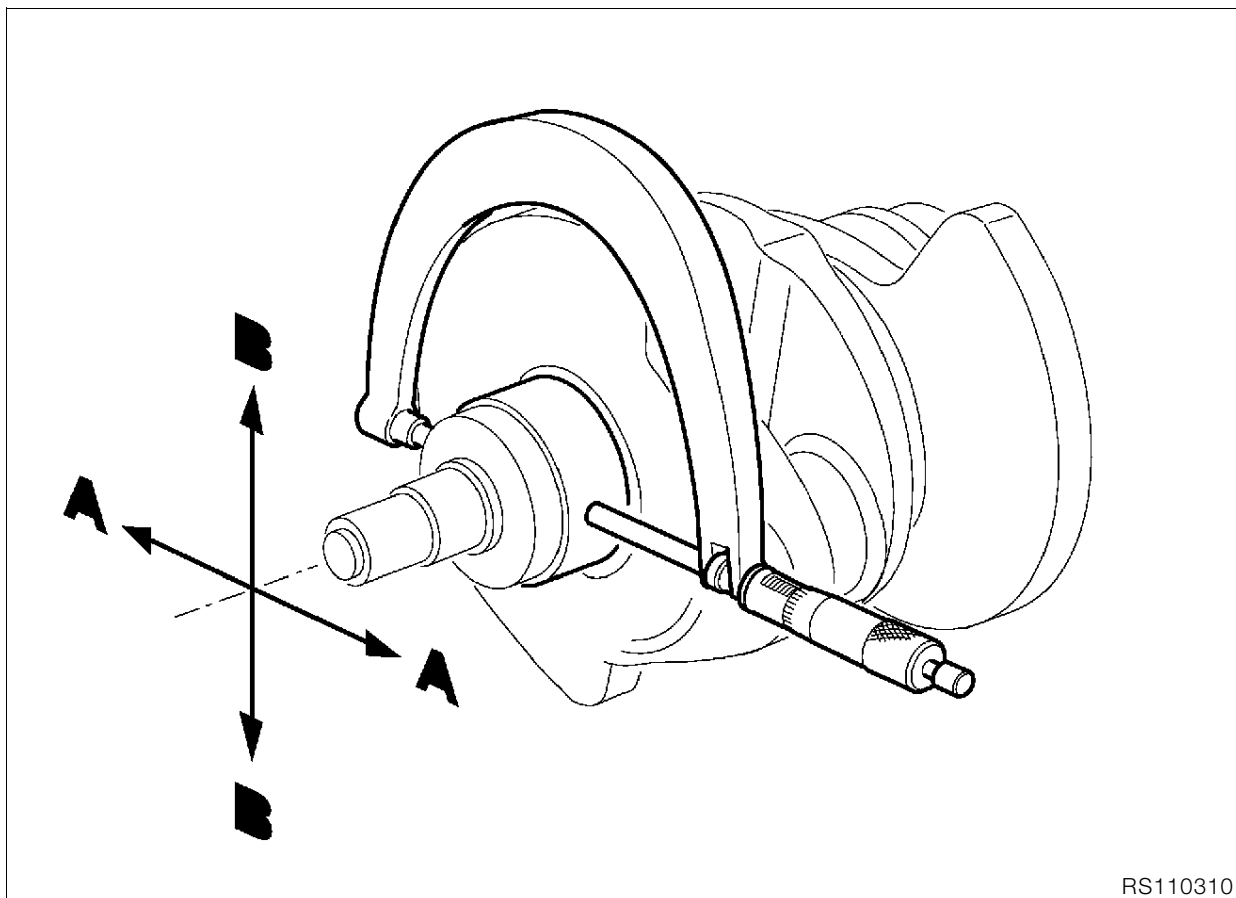
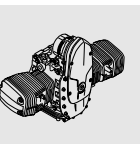

Measuring crankshaft bearing play

Measuring radial bearing play

- Measure main bearing journal with an external micrometer in two planes, A and B at right angles.
 - Enter measured values on record sheet.
- ➡ See Technical Data



Caution:

The crankshaft can only be reground in grinding stage 0; after this it must be rehardened and finished. Grinding stages are identified by a paint mark on the front crank web.

➡ See Technical Data

When replacing the bearing shells, make sure that the colour marks on the crankpins and big end bearings match.

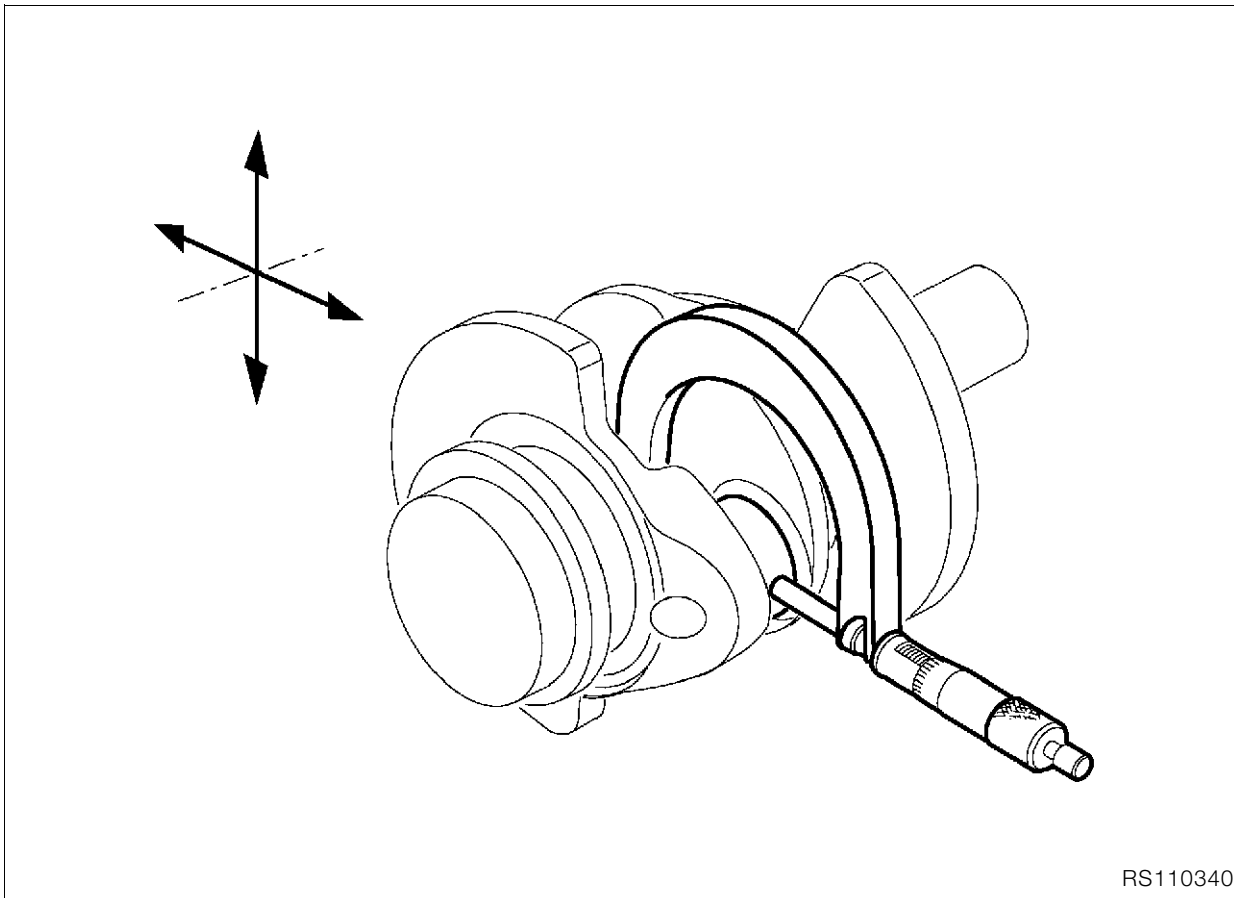
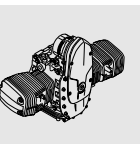

RS110340

Measuring big end bearing play

- Measure crankpin with an external micrometer in the thrust direction and at right angles to the thrust direction.

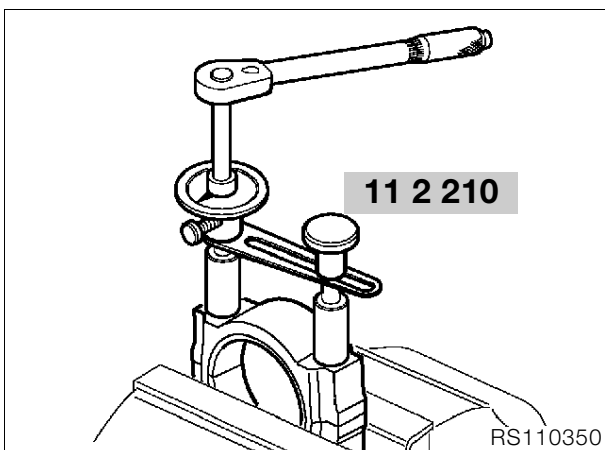

RS110350

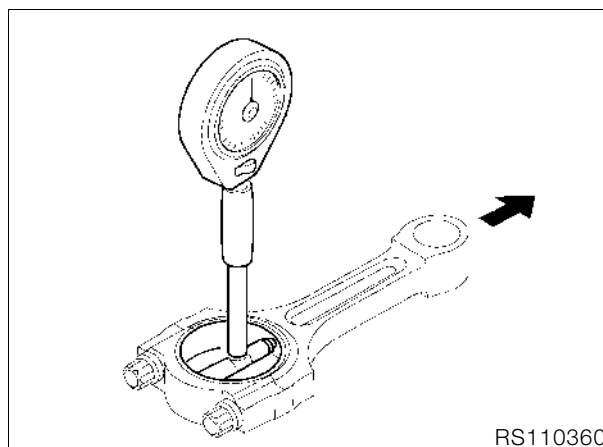

RS110360

- Measure big end bearing with internal gauge in thrust direction.
- Enter measured values on record sheet and calculate big end bearing play.

➡ See Technical Data

- Install bearing shells and assemble conrods.
- Using tightening angle indicator, **BMW No. 11 2 500**, tighten the big end bolts.

Tightening torque:

Big end bolts oiled
 Closing torque..... 20 Nm
 Tightening angle..... 80°

Assembling engine

Installing conrods

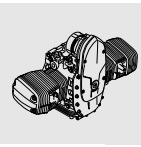
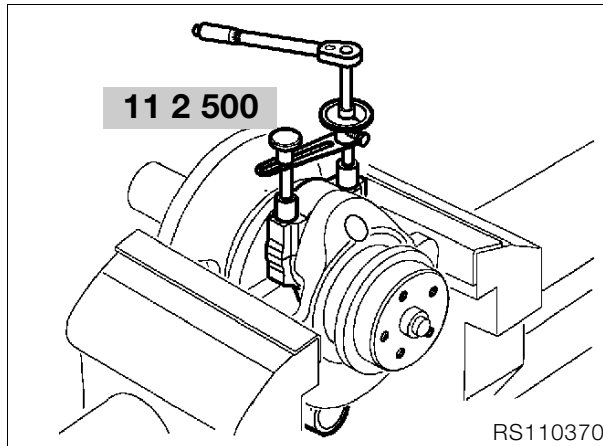

- Clamp crankshaft in a vise with protective jaws.
- Oil the big end bolts, screw them in by hand and tighten with tightening angle indicator, **BMW No. 11 2 500**.



Caution:

Oil the bearings.

Do not mix up conrods or bearing shells.

Always use new big end bolts.

Use a felt-tipped pen or similar to mark the installed positions on the conrods.



Tightening torque:

Big-end bolts (oiled)

Closing torque..... 20 Nm

Tightening angle..... 80°

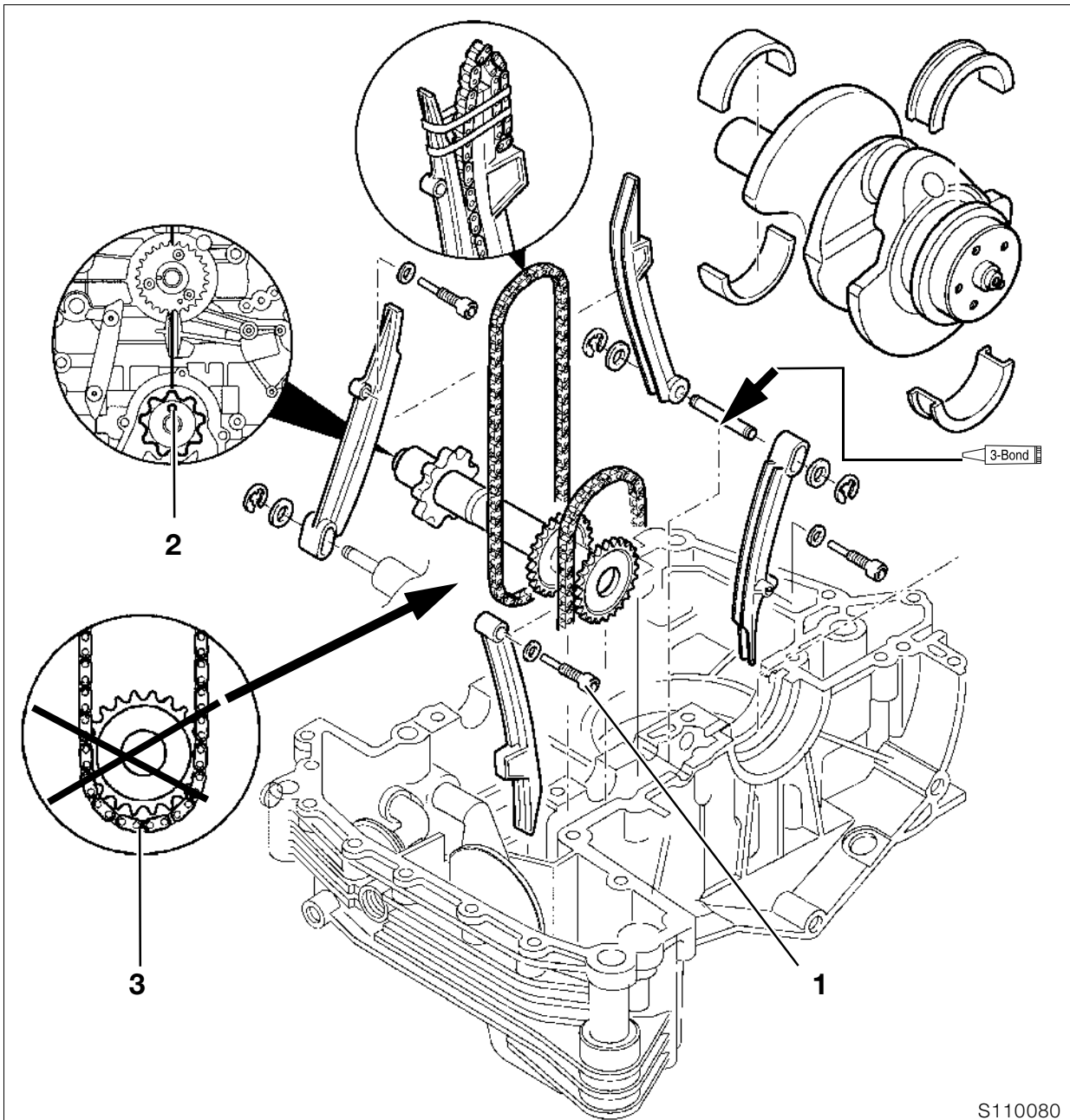
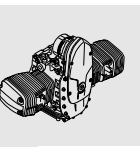

S110080

Installing crankshaft

⚠ Caution:
Oil the bearings.

Installing timing chain tensioning and slide rails

- Seal pivot pin for tensioner rail/slide rail at clutch side (arrow) with **3-Bond 1209**.
- Insert pivot screw (1) into chain tensioner rail, using a new seal.

⚠ Tightening torque:
Chain guide rail pivot pin 18 Nm

Installing auxiliary shaft/timing chains

- When installing the auxiliary shaft, make sure that the bore in the auxiliary shaft (2) facing the crankshaft is in line with the crankcase mating face.

⚠ Caution:
Timing chains (3) must mesh fully with auxiliary shaft sprockets.

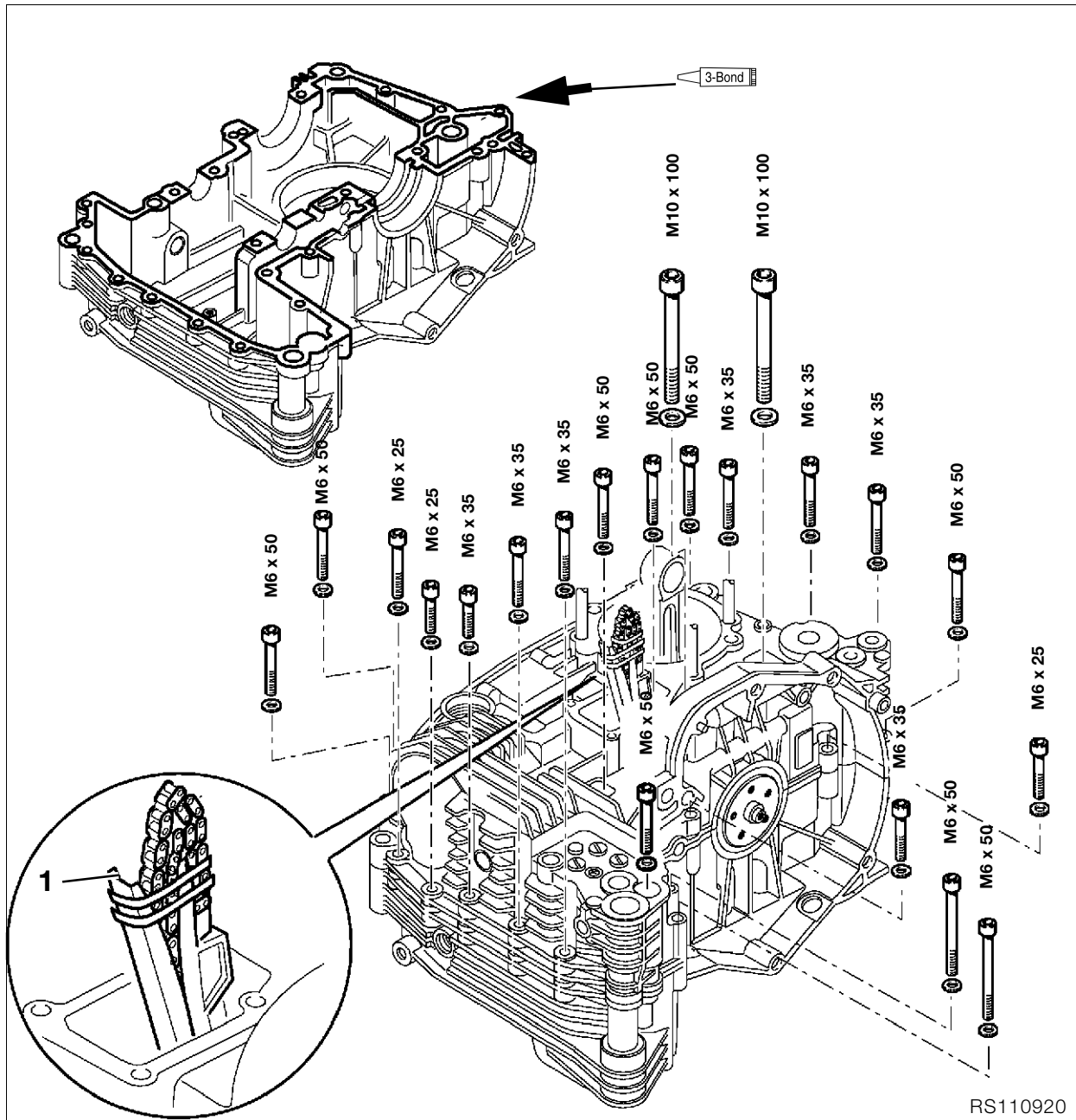

Assembling engine block

- Clean and degrease sealing faces (arrow) and coat with **3-Bond 1209**.
- Secure the timing chain with rubber band (1) to the timing chain tensioner and slide rail.

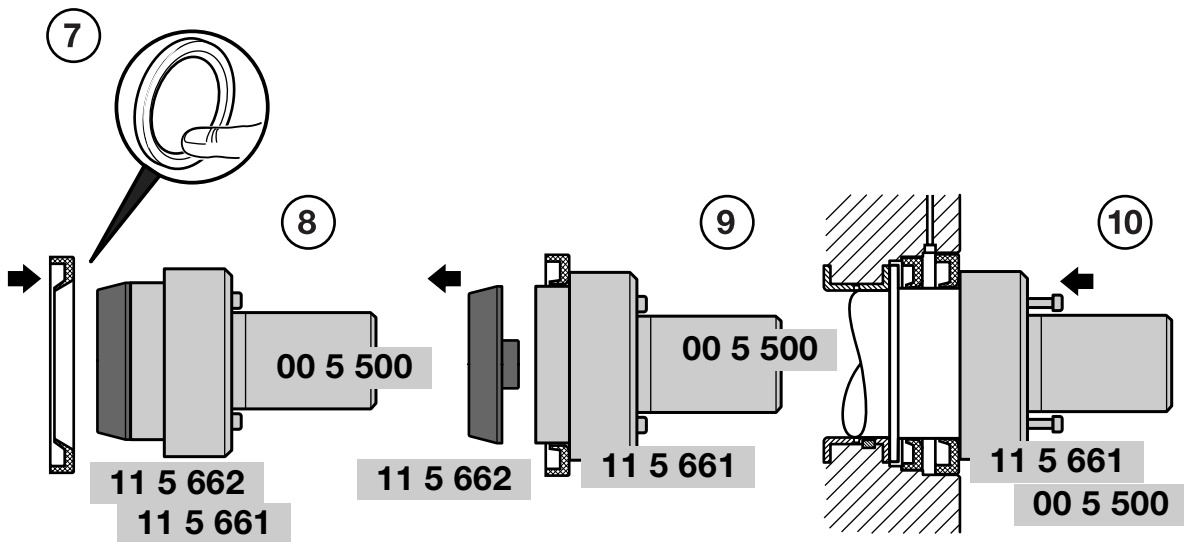
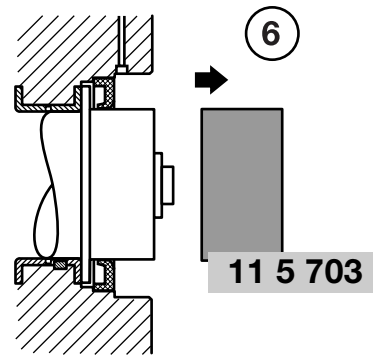
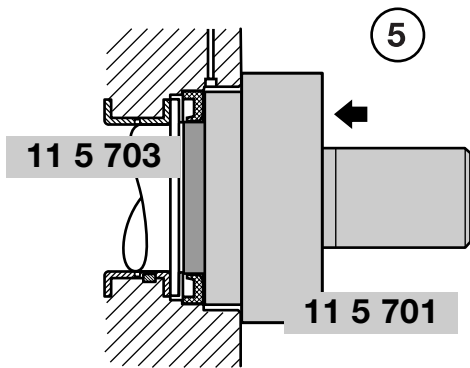
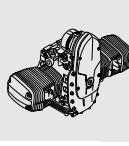
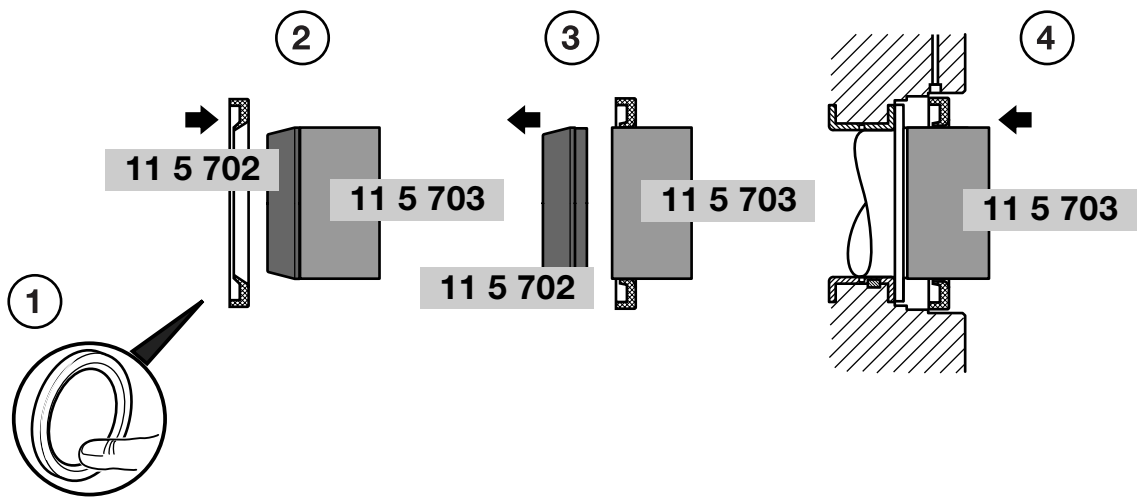

Installing radial shaft seals on crankshaft

Installing the crankshaft-end radial shaft seal

- Shape the lip of the radial shaft seal carefully by hand (1).
- Oil the radial shaft seal at the sealing/contact surface.
- Using assembly sleeve, **BMW No. 11 5 702**, mount the radial shaft seal with the closed side toward the clutch onto sleeve, **BMW No. 11 5 703**, (2).
- Remove assembly sleeve (3).
- Mount sleeve complete with radial shaft seal on crankshaft (4).
- Use drift, **BMW No. 11 5 701**, together with sleeve (5) to drive the radial shaft seal onto the crankshaft.
- Remove sleeve (6).

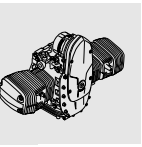

Installing the clutch-end radial shaft seal

- Shape the lip of the radial shaft seal carefully by hand (7).
- Oil the radial shaft seal at the sealing/contact surface.
- Using assembly sleeve, **BMW No. 11 5 662**, mount the radial shaft seal with the closed side toward the clutch onto drift, **BMW No. 11 5 661**, with handle, **BMW No. 00 5 500**, (8).
- Remove assembly sleeve (9).
- Using the drift, drive the radial shaft seal home (10).

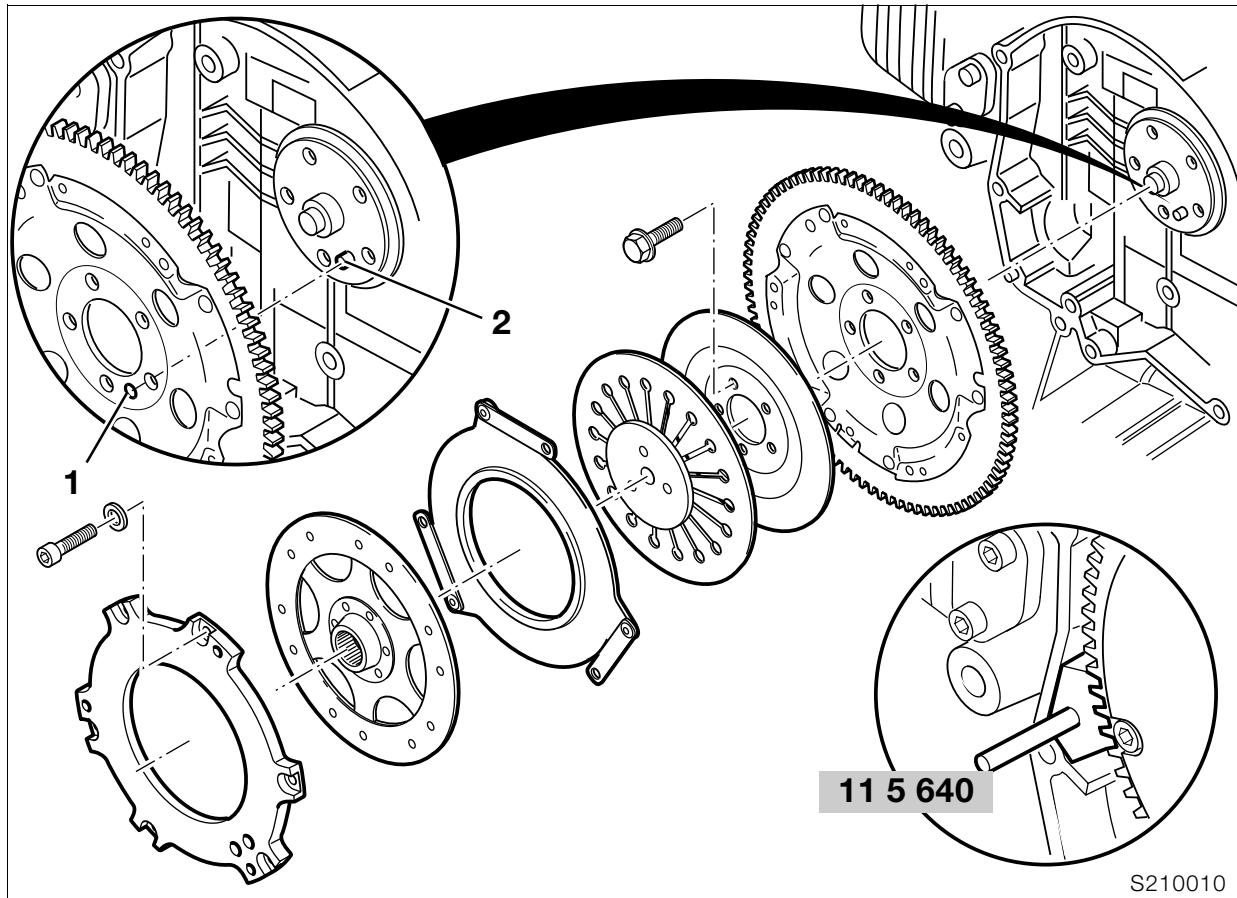

Installing clutch housing



Caution:

Always use new screws for housing and cover.

- Install clutch housing with mark (1) aligned with crankshaft mark (2).
- Install locking device, **BMW No. 11 5 640**, to lock clutch housing.
- Insert all screws by hand and tighten.



Tightening torque:

Clutch housing to crankshaft
 (screw threads oiled) 40 Nm
 Tightening angle 32°

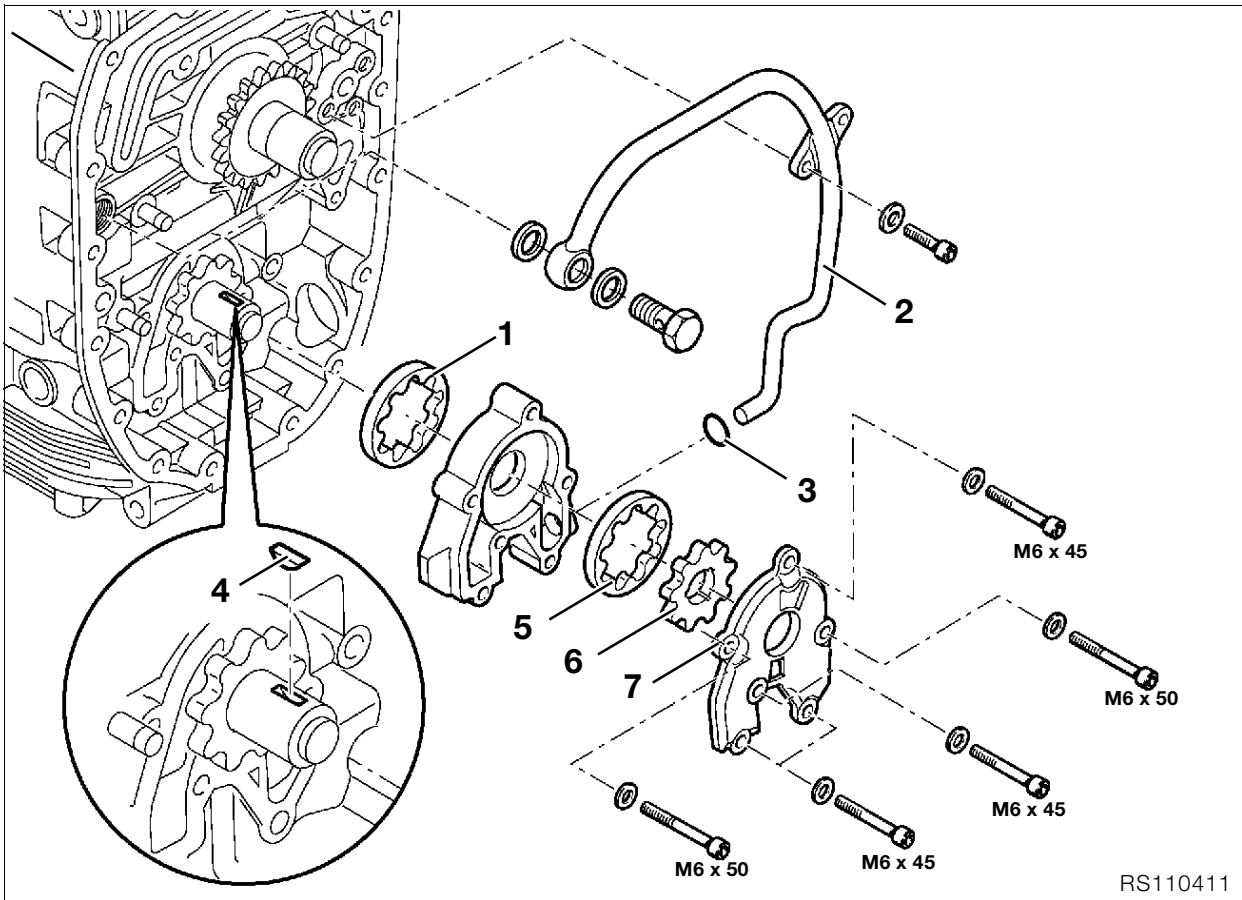

Installing oil pump



Caution:

Oil the friction faces.

- Install outer rotor (1) of oil pump in pump housing.
- Install oil pump housing with cooling oil pipe (2).



Caution:

O-ring (3) must be in perfect condition.

- Install Woodruff key (4), outer rotor (5) and inner rotor (6) in cooling oil pump.
- Secure housing cover (7) to oil pump.



Caution:

Note different lengths of screws.



Tightening torque:

M 6 screw	9 Nm
Pressure relief valve	42 Nm
Oil pressure switch.....	30 Nm

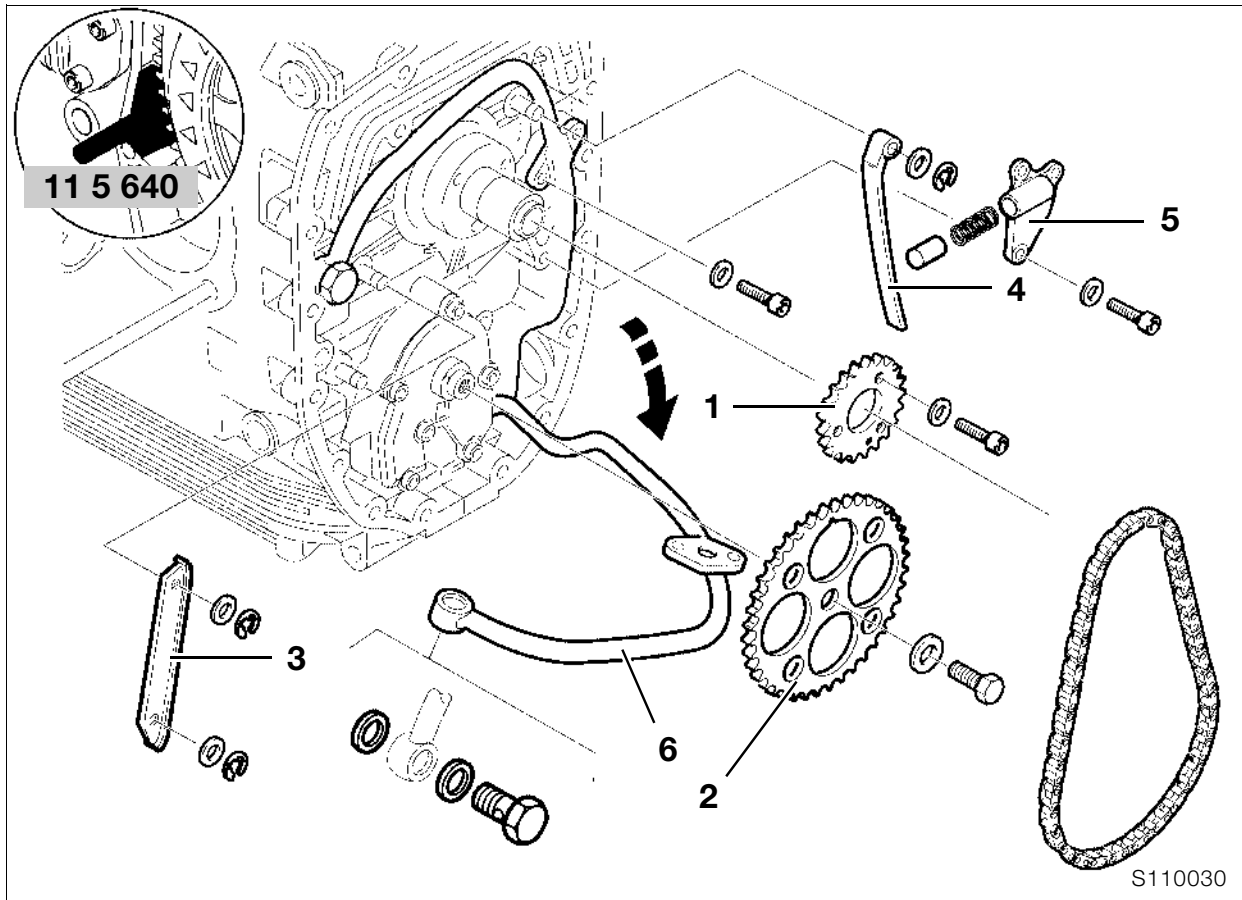

Installing auxiliary shaft drive

- Align crankshaft mark with mark on auxiliary shaft.



Caution:

Adjust according to the adjusting instructions.
 ► See Technical Data

- Install locking device, **BMW No. 11 5 640**, to lock clutch housing.
- Install chain sprocket (1).



Tightening torque:

M 6 screw 10 Nm

- Install drive-shaft chain with chainwheel (2).



Tightening torque:

Securing screw in chainwheel 70 Nm

- Install and secure chain guide rail (3).
- Install and secure chain tensioner rail (4).
- Install chain tensioner housing (5) with piston and spring.



Tightening torque:

M 6 screw 9 Nm

- Tighten cooling oil line (6).



Caution:

Use a new sealing ring.



Tightening torque:

M6 screw 10 Nm
 Banjo bolt for cooling oil line
 with oil vent valve 25 Nm

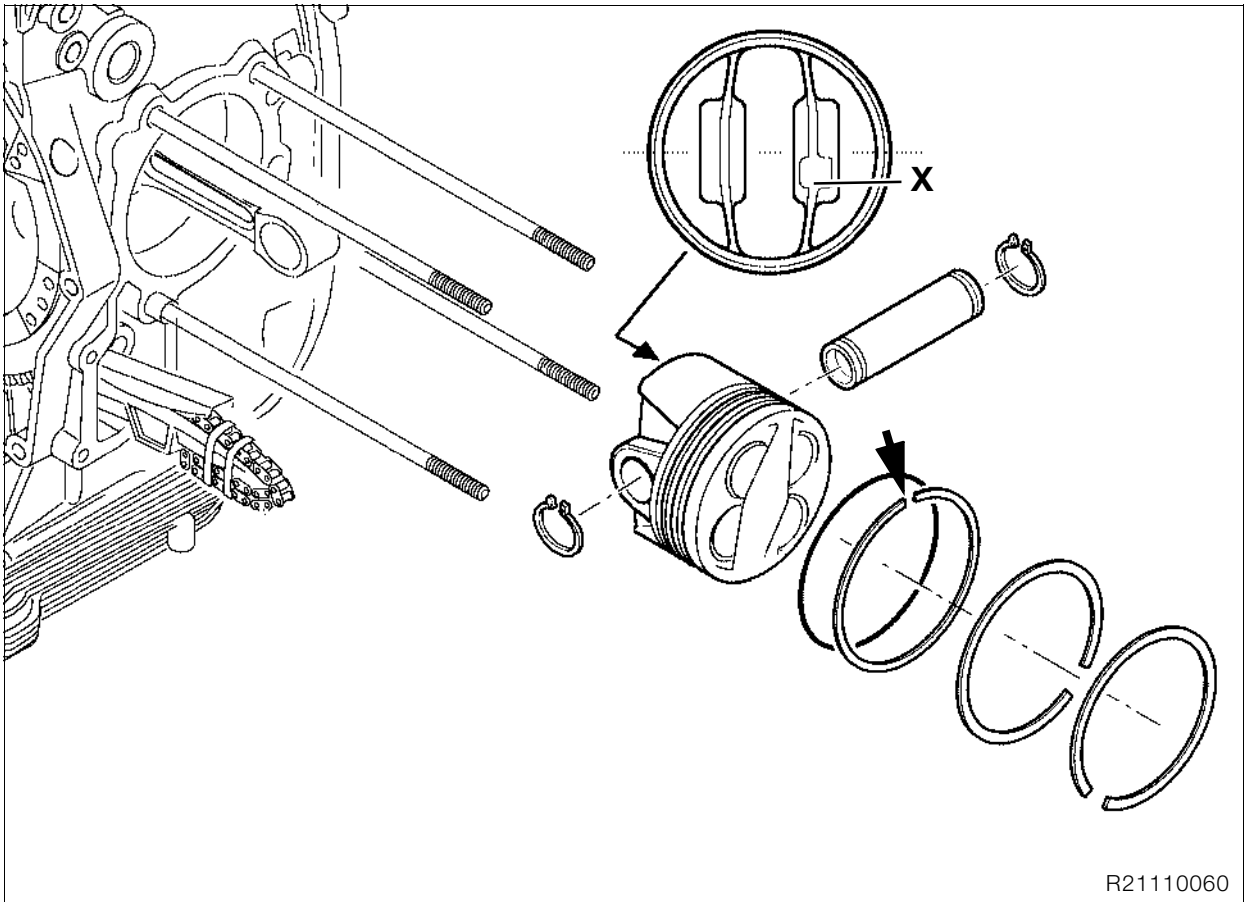

Installing piston

- Turn oil scraper ring so that gap (arrow) is at top.
- Install piston rings with gaps offset by 120°.

Production locating point **X** = install on exhaust side.



Caution:

Make sure that retaining rings are properly seated on piston pin.
Oil the friction faces.
Always use pistons of the same weight class in any one engine.

Markings: + or -
 See Technical Data



Caution:

Always install pistons and cylinders in pairs.
Do not mix up pistons and piston pins.

Piston size identification:

On piston crown A, B, AB (for either A or B cylinder), and on cylinder A, B.

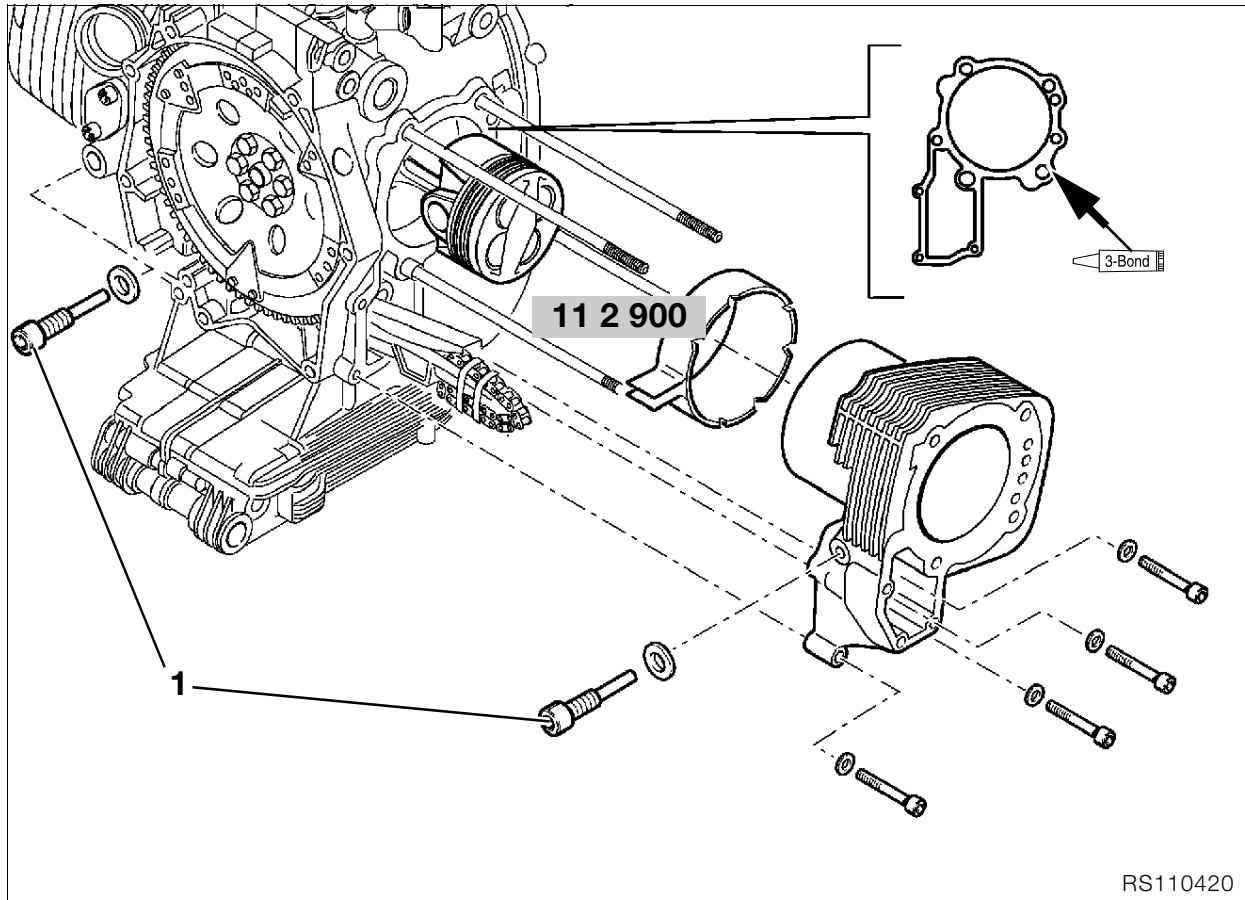

Installing cylinder

- Clean and degrease cylinder base sealing face (arrow) and apply **3-Bond 1209**.
- Oil the cylinder wall.
- Compress the piston rings with a clamping strap, **BMW No. 11 2 900**.
- Install the cylinder and at the same time pass the timing chain and the tensioner and guide rails through the timing case cavity.
- Tighten cylinder securing screws.
- Fit new seals to pivot pins for chain guide rail (1).
- Install chain sprocket.

Tightening torque/tightening sequence:

1. M 8 screw 20 Nm
2. M 6 screw 9 Nm
3. Pivot screw for chain guide rail 18 Nm

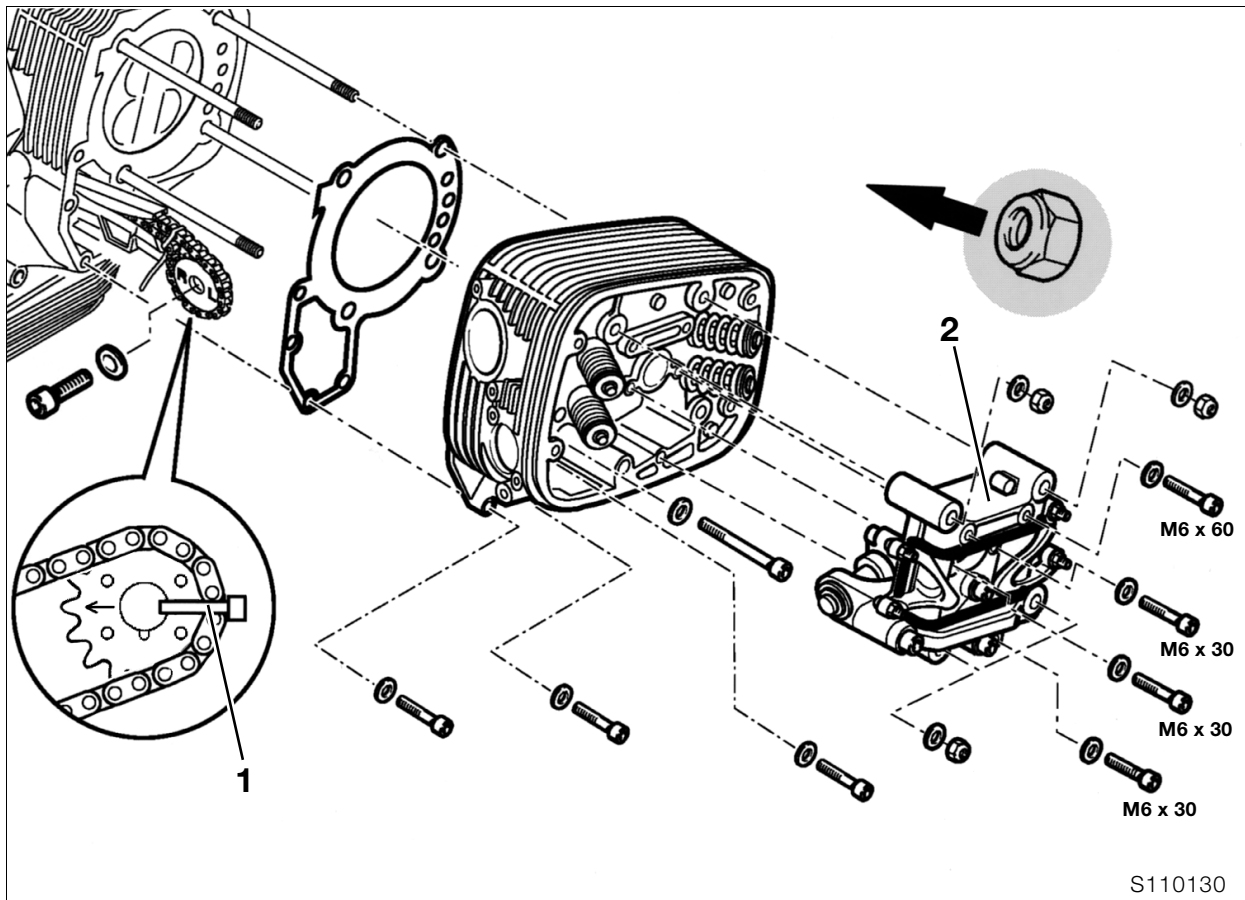

Installing cylinder head

- Install cylinder head gasket.
- Fit cylinder head and insert correctly positioned camshaft chain sprocket (1) and timing chain into chain cavity.
- Install valve gear carrier (2).
- Tighten cylinder head securing screws and nuts.

Caution:

Install cylinder head nuts with collar (arrow) toward cylinder head.

Tightening torque/tightening sequence:

1. Tighten cylinder head nuts (oiled) in diagonally opposite sequence
 - 1.1 Tighten all nuts 20 Nm
 - 1.2 Tighten all nuts to correct angle 90°
 - 1.3 Tighten all nuts to correct angle 90°
2. M 10 screw 40 Nm
3. M 6 screw 9 Nm

Tightening torque:

After 1,000 km (600 miles), tighten cylinder head nuts in diagonally opposite sequence

1. Slacken one nut
2. Tighten nut to initial torque 20 Nm
3. Tighten nut to wrench angle 180°
4. Slacken and retighten M 10 screw 40 Nm

- Fit camshaft chain sprocket in accordance with adjustment specification.
- Install locking device, **BMW No. 11 5 640**, to lock clutch housing.
- Tighten camshaft chain sprocket.

Tightening torque:

Camshaft sprocket retaining screw 65 Nm

- Insert the left-side camshaft sprocket with pin into the camshaft and set the left cylinder to firing TDC.
- Fit camshaft chain sprocket in accordance with adjustment specification.
- Tighten camshaft chain sprocket.
- Install chain tensioner.
- Check that marks on camshaft sprockets are in accordance with adjustment specification.

Tightening torque:

Chain tensioner 32 Nm

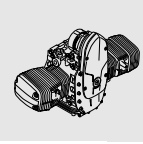
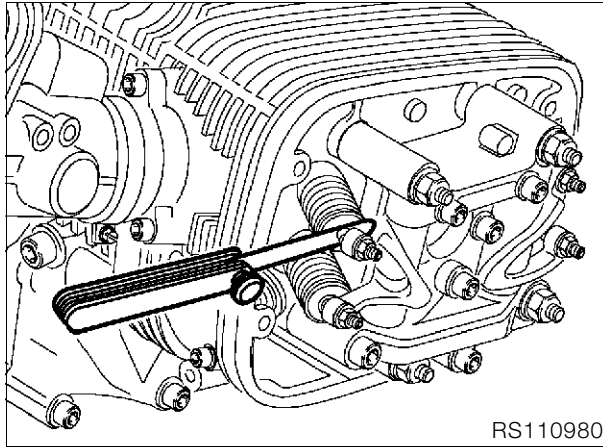

Adjusting valve clearances

- Set piston to firing TDC on the ignition stroke.
- Measure valve clearance with feeler gauge.
- Correct valve clearance with adjusting screw and tighten locknut.

Valve clearances with engine cold (max. 35 °C/95 °F):

Inlet	0.15 mm (0.0056 in)
Exhaust	0.30 mm (0.0118 in)



Tightening torque:

Locknut	8 Nm
---------------	------

- Recheck valve clearances. Feeler gauge must pull through between valve stem and adjusting screw with slight resistance.

Installing right cylinder head

Adjustment specification



Caution:

When assembling, **always** start with the **right-hand** cylinder.

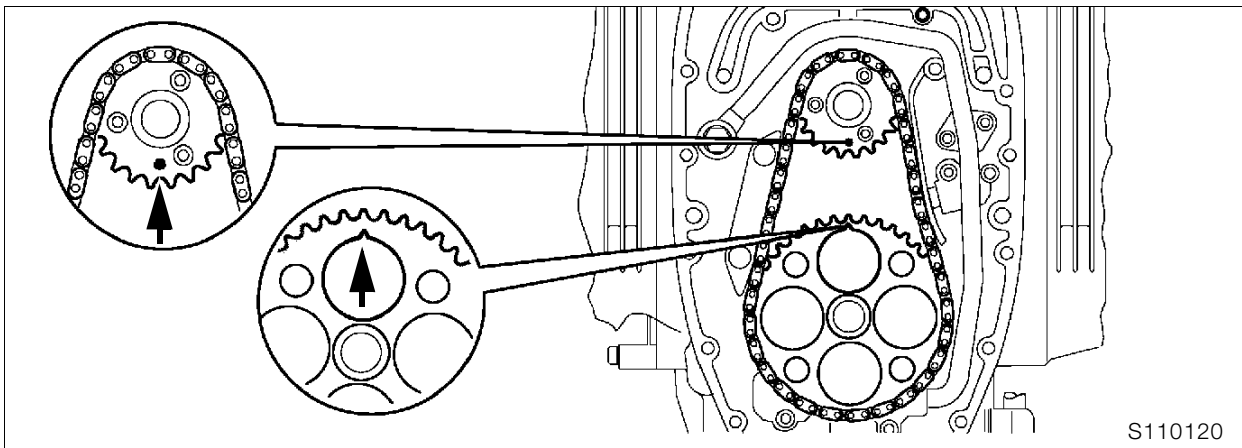

Right cylinder = at firing TDC:
marks (arrows) on chainwheel/auxiliary shaft and
chain sprocket/crankshaft are aligned.

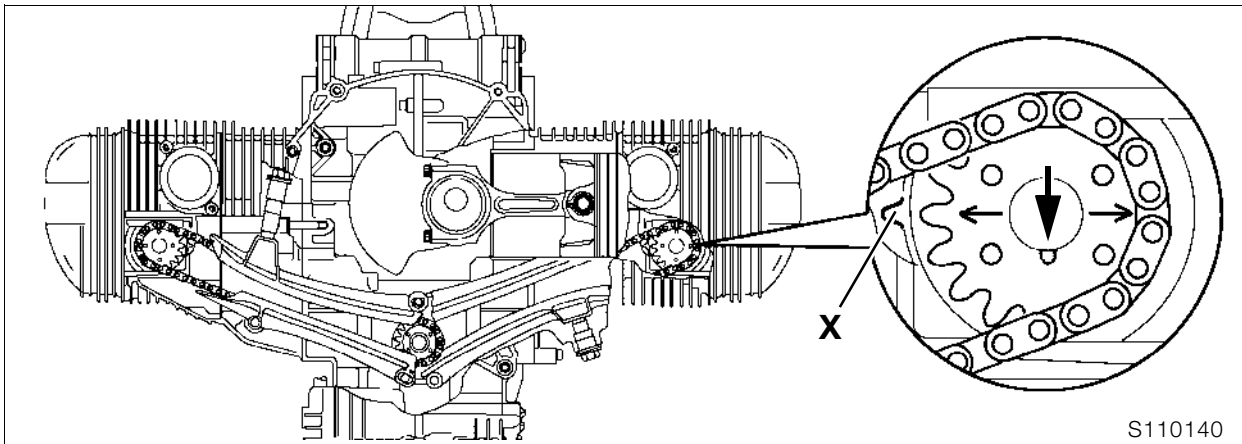

- Lock engine at firing TDC by inserting pin, **BMW No. 11 2 650**, through holes in clutch housing and engine block.



Note:

With engine installed, set engine to TDC with dial gauge holder, **BMW No. 00 2 650**, and dial gauge, **BMW No. 00 2 510**.

Right cylinder = at firing TDC:
Locating pin (arrow) on right camshaft sprocket is at
bottom.

Mark (**arrow**) and tip of tooth on right camshaft gear
are **exactly aligned** with mark **X** on valve gear
carrier.

- Recheck setting with timing chain tensioner in-
stalled.

Installing left cylinder head

Adjustment specification



Caution:

When installing, **always** begin with the **right-hand** cylinder.

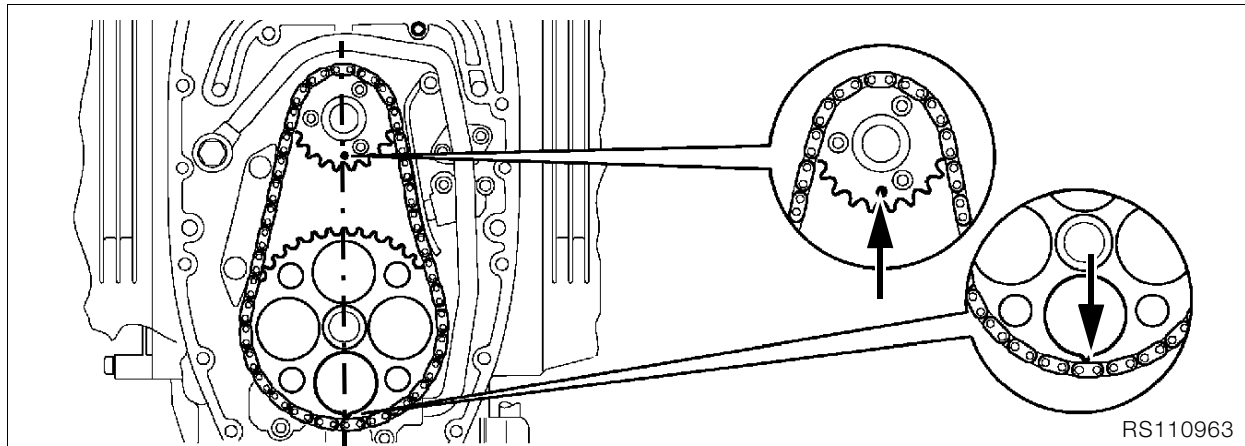

Left cylinder = at firing TDC: marks (arrows) on chain sprocket/auxiliary shaft and chainwheel/crankshaft at bottom

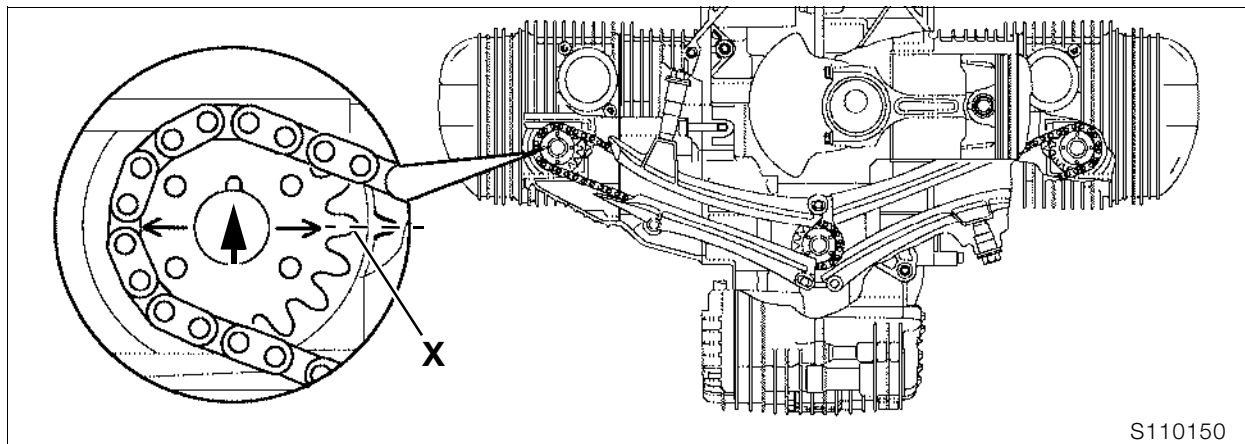

- Lock engine at firing TDC by inserting pin, **BMW No. 11 2 650**, through holes in clutch housing and engine block.



Note:

With engine installed, set engine to TDC with dial gauge holder, **BMW No. 00 2 650**, and dial gauge, **BMW No. 00 2 510**.

Left cylinder = at firing TDC:

Locating pin (arrow) on left camshaft sprocket is at top.

Mark (**arrow**) and tip of tooth of left camshaft gear are **exactly aligned** with mark **X** on valve gear carrier.

- Recheck setting with timing chain tensioner installed.

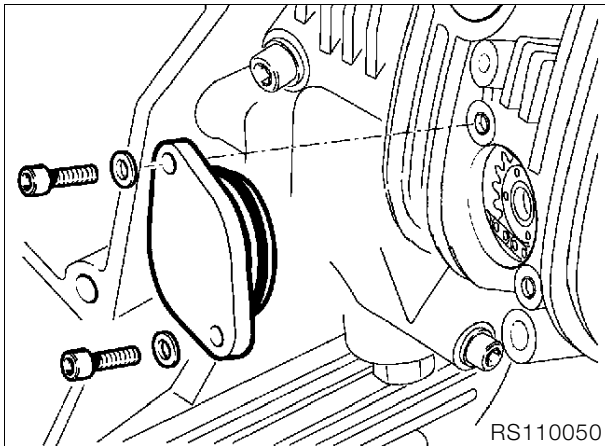
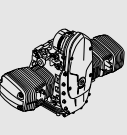

- Install the end cover with O-ring in perfect condition.

Tightening torque:
 M 6 screw 9 Nm

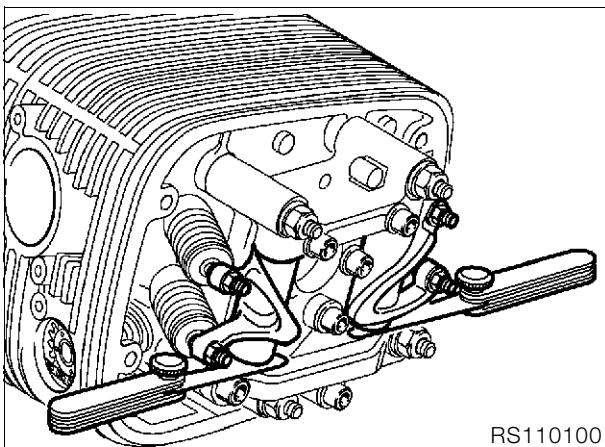

- Adjust the holder for minimum end float.

Rocker end float:
 min. 0.05 mm (0.002 in)
 max. 0.40 mm (0.016 in)

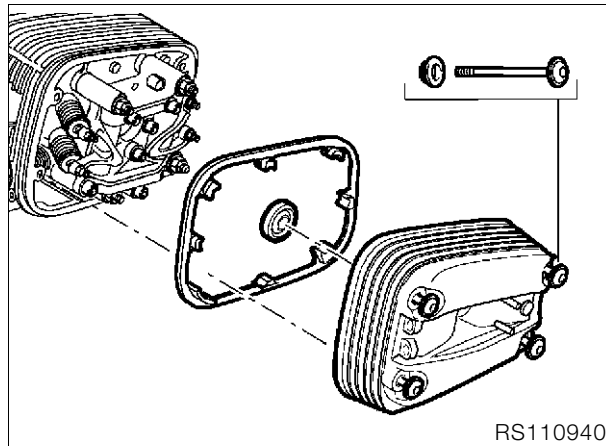

- Install cylinder head cover.

Caution:
 Make sure that gaskets are correctly seated. Gaskets and sealing faces must be free from oil and grease.

Tightening torque:
 Cover screw 9 Nm

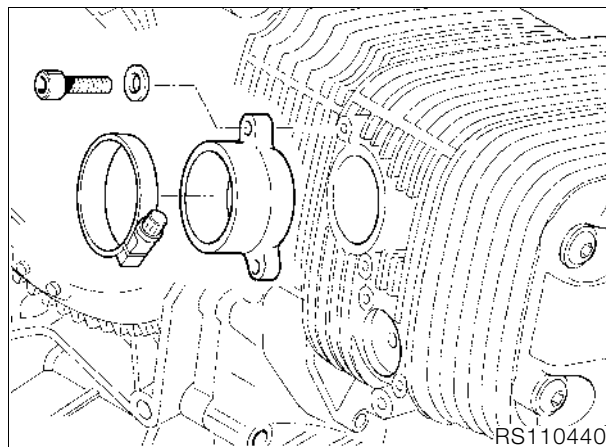

- Secure air intake stub pipe.

Tightening torque:
 M 6 screw 9 Nm

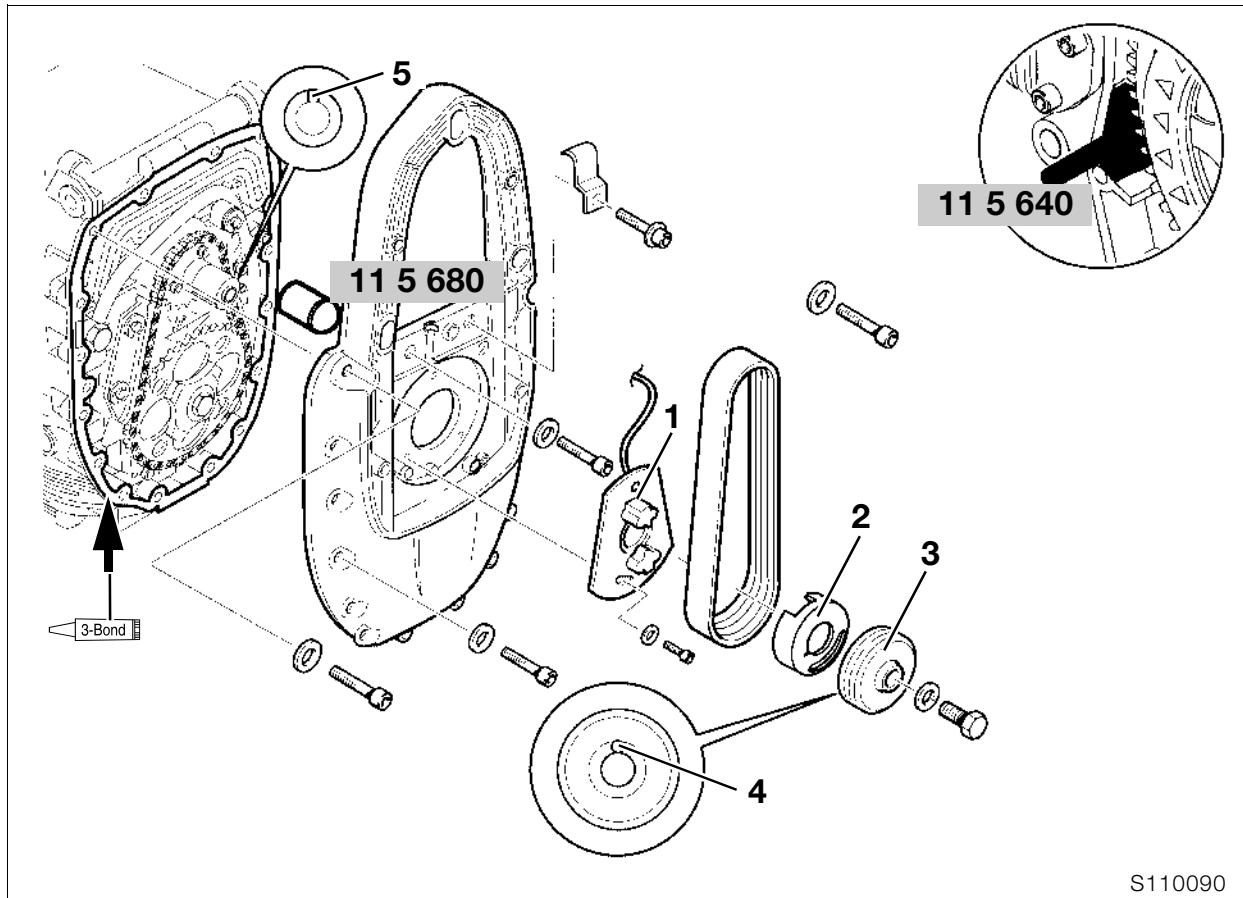

Installing alternator mount cover

- Place assembly sleeve, **BMW No. 11 5 680**, on crankshaft.
- Clean and de-grease sealing face (arrow) and apply **3-Bond 1209**.
- Install alternator mount cover.

Tightening torque:

M 8 screw	20 Nm
M 6 screw	9 Nm

Installing magnetic gate/belt pulley

- Install Hall-effect trigger plate (1).
- Install locking device, **BMW No. 11 5 640**, to lock clutch housing.
- Secure rotor (2) of Hall-effect gate to the Poly-V-belt pulley (3) with, for example, **Loctite instant adhesive**.
- Install the Poly-V belt pulley.

Caution:

Seat retainer for Hall-effect gate rotor (4) in groove in crankshaft (5).

Tightening torque:

Retaining screw for belt pulley.....	50 Nm
--------------------------------------	-------

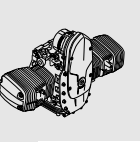
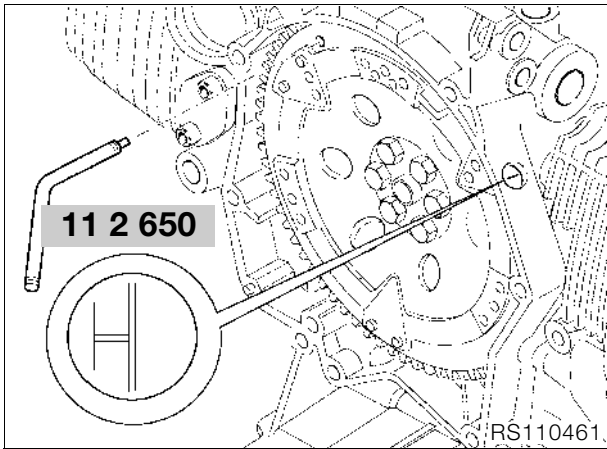

Timing the ignition

- Using TDC locating pin, **BMW No. 11 2 650**, lock the clutch housing.
- Connect **BMW** MoDiTeC with adapter cable to Hall-effect gate plate.
- Set the timing, following the tester instructions.
- Remove the TDC locating pin.

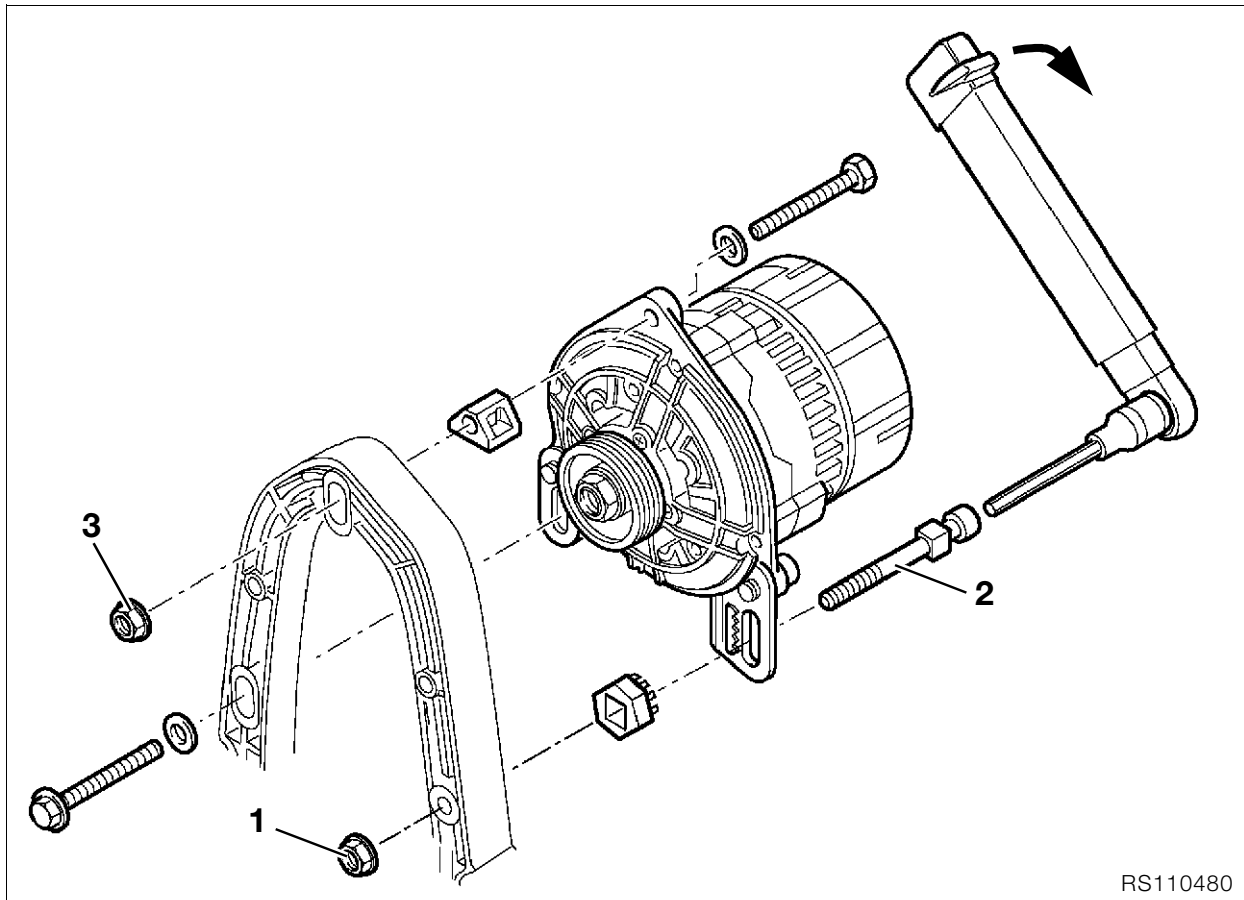

Installing alternator

- Install alternator.

Poly-V belt adjusting procedure:

Poly-V belt installation procedure:

- Slightly tighten hex nut (1) on adjusting screw (2) by hand (**do not use tools**).
- Tighten adjusting screw (2) with a torque wrench and keep preload applied. Tighten upper retaining nut (3), then remove torque wrench from adjusting screw.

Tightening torque:

Preload Poly-V belt
with adjusting screw..... 8 Nm
Alternator
to alternator support cover..... 20 Nm

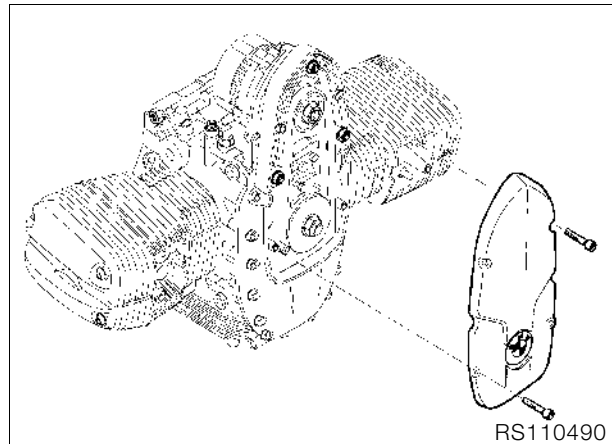

- Install front cover.

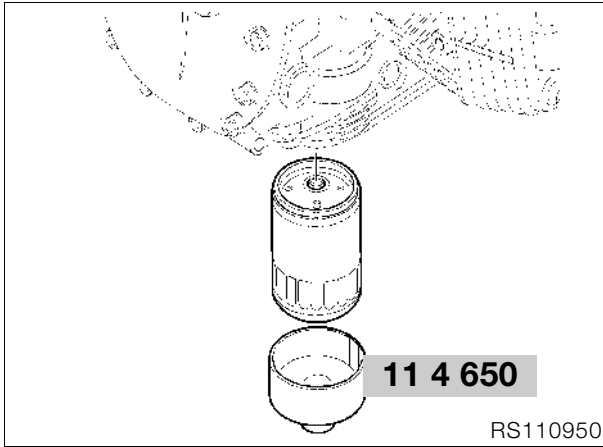
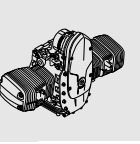

Installing engine

- Installation is the reverse of the removal procedure.

- Install oil filter with oil filter wrench, **BMW No. 11 4 650**.
- Install the oil drain plug with a new seal.

 **Tightening torque:**
Oil filter (sealing face lightly oiled) 11 Nm
Oil drain plug 32 Nm

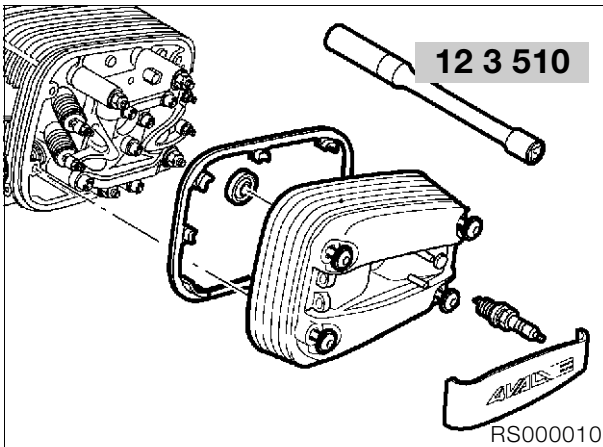

- Install spark plugs with spark plug socket wrench, **BMW No. 12 3 510**.

 **Tightening torque:**
Spark plug 20 Nm

12 Engine electrics

Contents

Page

Technical Data	3
Removing and installing coil and ignition lead	5
Checking ignition coil resistance	5
Removing and installing alternator	6
Poly-V belt adjusting procedure:	6
Disassembling/assembling alternator	7
Checking alternator	7
Checking armature for short to ground (earth)	7
Disassembling/assembling alternator (Option 50 A)	8
Checking alternator	8
Checking armature for short to ground (earth)	8
Removing and installing starter motor	9
Disassembling/assembling starter motor	10
Replacing carbon brushes	10
Checking starter motor	10
Checking starter relay	10
Removing and installing magnetic gate	11
Timing the ignition	12

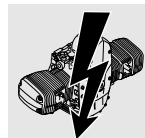

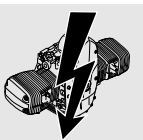

Technical Data		R 1150 GS
Starter motor		
Type		Permanent-magnet motor with planetary gear drive
Gear ratio		Planetary gears 5.5 : 1
Power rating	kW	1.1
Alternator		
Type		Three-phase alternating-current generator with integrated all-electronic voltage regulator Standard: Denso, Option: Bosch
Drive		Poly-V belt
Gear ratio		1 : 1.5
Maximum output rating	W/V	560/14 (option: 700/14)
Maximum current at engine speed 4,000 rpm	A	40 (option: 50)
Nominal current at engine speed 1,000 rpm	A	10 (option: 18)
Max. operating speed	rpm	18,000 (option: 20,000)
Spark plug		
NGK		BKR 7 EKC
Electrode gap	mm (in)	0.8 (0.03)
Wear limit	mm (in)	1.0 (0.04)
Thread	metric	M 14 x 1.25
Ignition		
Ignition system		Motronic MA 2.4 (mapped characteristic control)
Ignition trigger		Two magnetic gates (Hall-effect transmitters) driven by crankshaft
Ignition timing	°CS	0° ... + 43° before TDC
Static ignition timing	°CS	Adjustment at TDC
Ignition coil		
Twin-spark coil		Beru
Resistance: Primary between terminals 15 and 1	Ω	~0.5
Secondary between terminals 4a and 4b	kΩ	~7.5 when cold

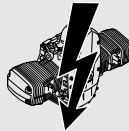

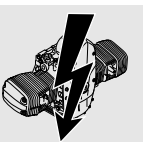

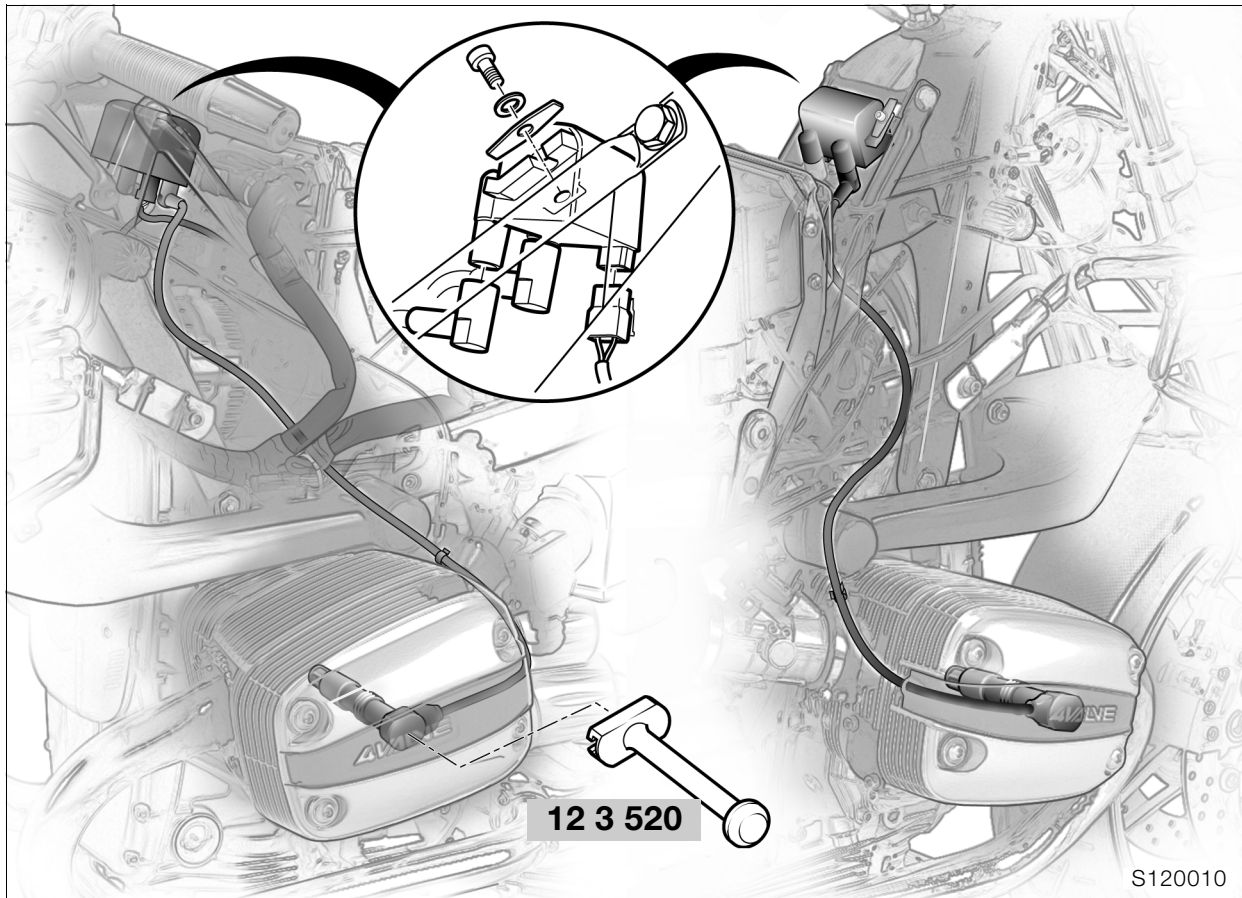

12 3 520

S120010

Removing and installing coil and ignition lead

- Remove the seat.
- Remove right side trim panel.
- Disengage fuel tank.
- Seal the fuel feed and return lines with hose clips, **BMW No. 13 0 010**, and disconnect.
- Disconnect breather lines.
- Disconnect plug for fuel pump.
- Remove fuel tank.



Caution:

Switch off ignition. Disconnect ground (earth) cable from battery and insulate it.

- Disconnect plug from Hall sensor.
- Remove fasteners and lift out the Motronic control unit.
- Remove the ignition coil.
- Disconnect plug.
- Disconnect ignition lead.
- Remove spark plug cover (4).
- Pull off spark plug cap with special puller, **BMW No. 12 3 520**.
- Remove ignition leads.
- Installation is the reverse of the removal procedure.
- Switch on the ignition.
- Without starting the engine, fully open the throttle once or twice so that the Motronic control unit can register the throttle-valve positions.



Note:

Disconnecting the battery deletes all entries (e.g. faults, settings) stored in the Motronic control unit's memory.

Loss of settings can temporarily impair the operating characteristics when the engine is restarted.

Checking ignition coil resistance

- Test with **BMW MoDiTeC**.

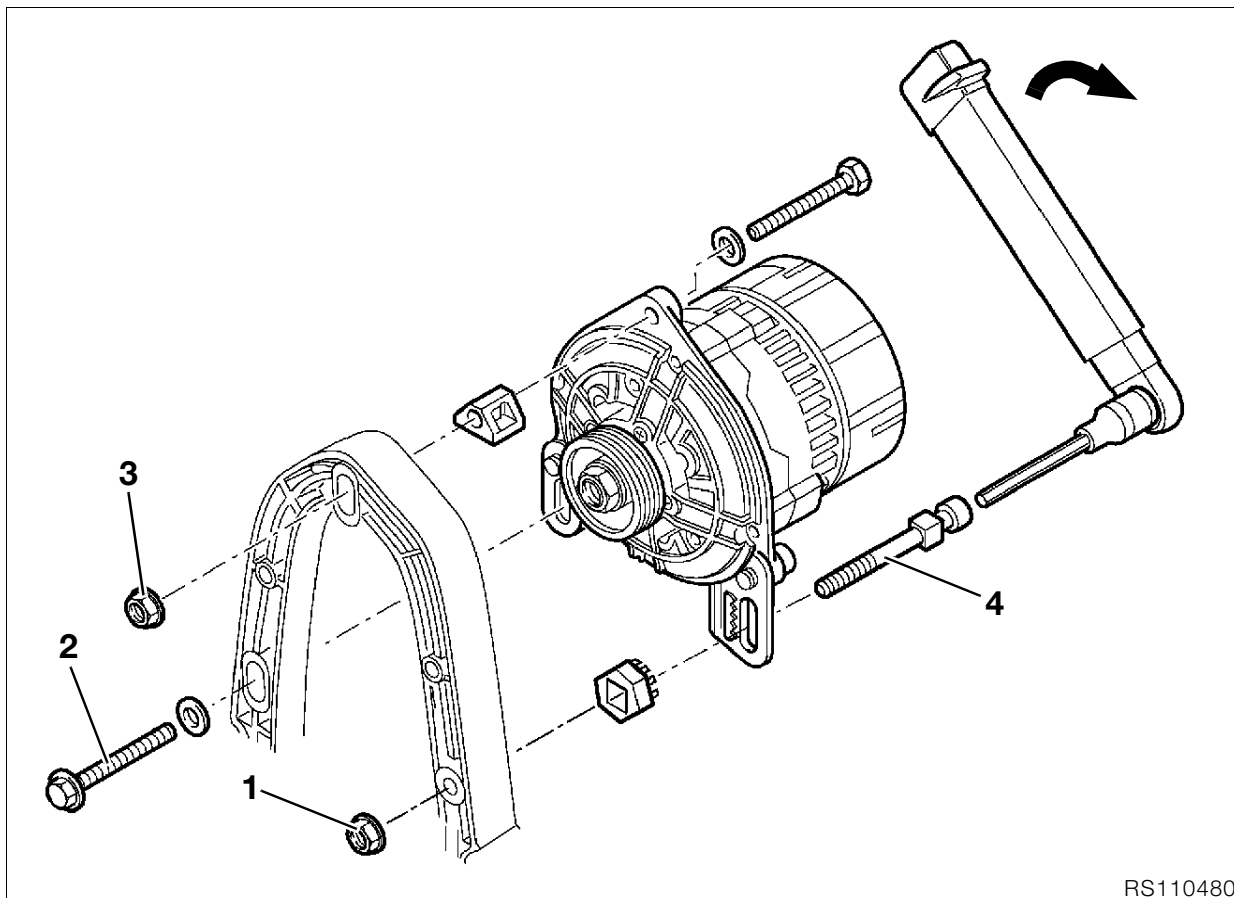
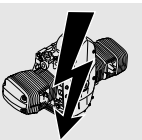

RS110480

Removing and installing alternator

- Remove the seat.
- Remove side panel.

Caution:

Disconnect earth (ground) lead from battery. Insulate earth (ground) lead.

- Disengage fuel tank.
- Seal the fuel feed and return lines with hose clips, **BMW No. 13 3 010**, and disconnect.
- Disconnect breather lines.
- Disconnect plug for fuel pump.
- Remove fuel tank.
- Remove Motronic control unit.
- **[ABS]** Remove the pressure modulator.
- Remove front cover from engine.
- Disconnect the leads from the alternator.
- Remove alternator retainers (1, 2, 3).
- Remove bolt (4) and nut (5).
- Remove Poly-V belt.
- Remove strut (3) from frame on left.
- Remove the alternator.

Caution:

Avoid scratching the components; use masking tape if necessary.

- Installation is the reverse of the removal procedure.
- Switch on the ignition.
- Without starting the engine, fully open the throttle once or twice so that the Motronic control unit can register the throttle-valve positions.

Note:

Disconnecting the battery deletes all entries (e.g. faults, settings) stored in the Motronic control unit's memory.

Loss of settings can temporarily impair the operating characteristics when the engine is restarted.

Poly-V belt adjusting procedure:

Poly-V belt installation procedure:

- Place the Poly-V belt in position, tension it and turn the engine over once, then relieve belt tension.

Poly-V belt tensioning procedure:

- Loosen alternator retainers (1, 2, 3).
- Slightly tighten hex nut (1) on adjusting screw (4) by hand (**do not use tools**).
- Tighten adjusting screw (4) with a torque wrench and keep preload applied. Tighten upper retaining nut (3), then remove torque wrench from adjusting screw.



Tightening torque:

Poly-V belt preload.....	8 Nm
Alternator	
to alternator support cover.....	20 Nm
Positive lead to alternator.....	15 Nm
Belt pulley to alternator	50 Nm

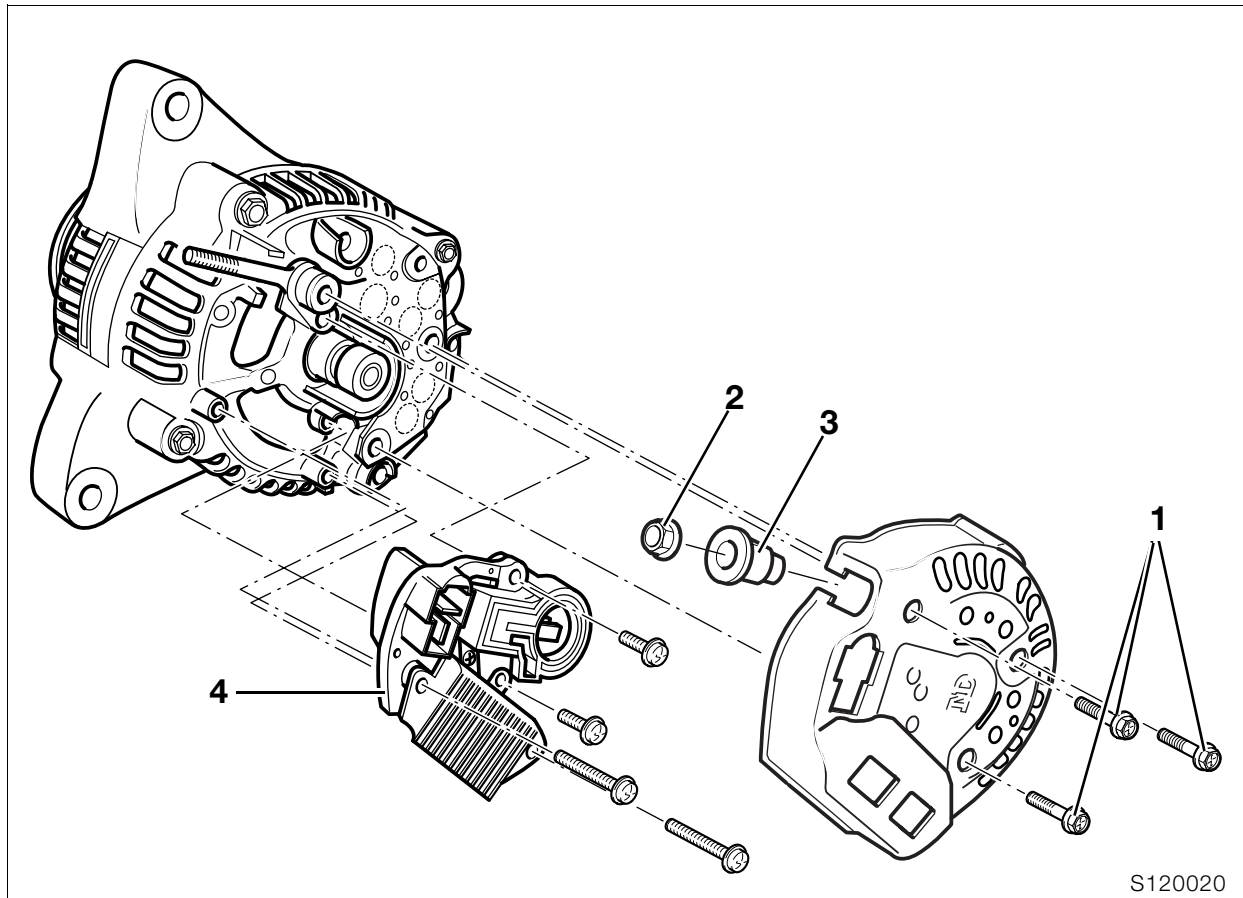

S120020

Disassembling/assembling alternator

- Remove the cover retaining screws (1).
- Unscrew nut (2) and remove sleeve (3).
- Remove the cover.
- Remove voltage regulator (4).
- Installation is the reverse of the removal procedure.



Note:

The belt pulley cannot be removed.

Checking alternator

- Test with **BMW** MoDiTeC.

Checking armature for short to ground (earth)

- Test with **BMW** MoDiTeC.

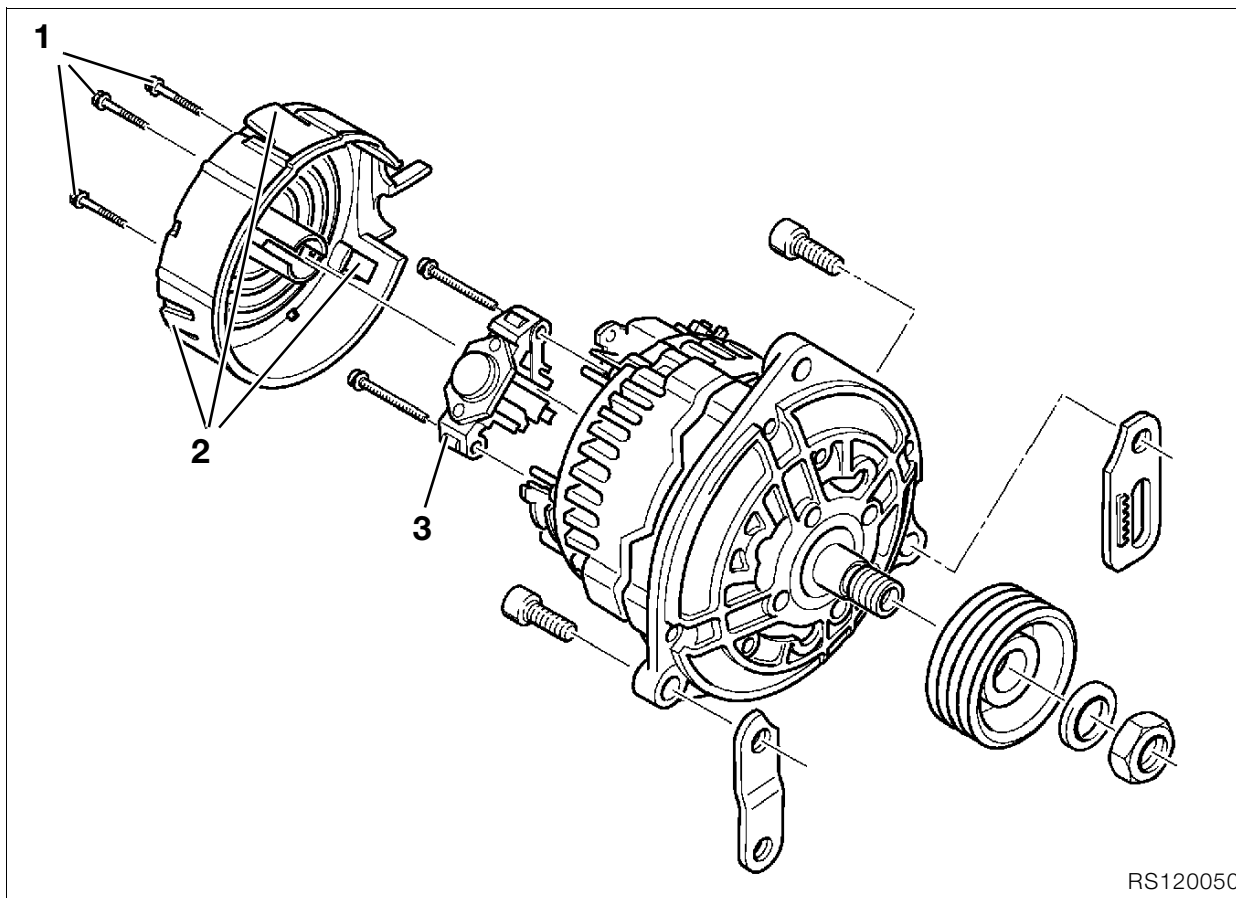
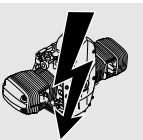

Disassembling/assembling alternator (Option 50 A)

- Remove the cover retaining screws (1).
- Release clips (2) and remove the cover.
- Remove voltage regulator (3).
- Remove the Poly-V belt pulley.
- Installation is the reverse of the removal procedure.

 **Tightening torque:**
Belt pulley to alternator 50 Nm

Checking alternator

- Test with **BMW** MoDiTeC.

Checking armature for short to ground (earth)

- Test with **BMW** MoDiTeC.

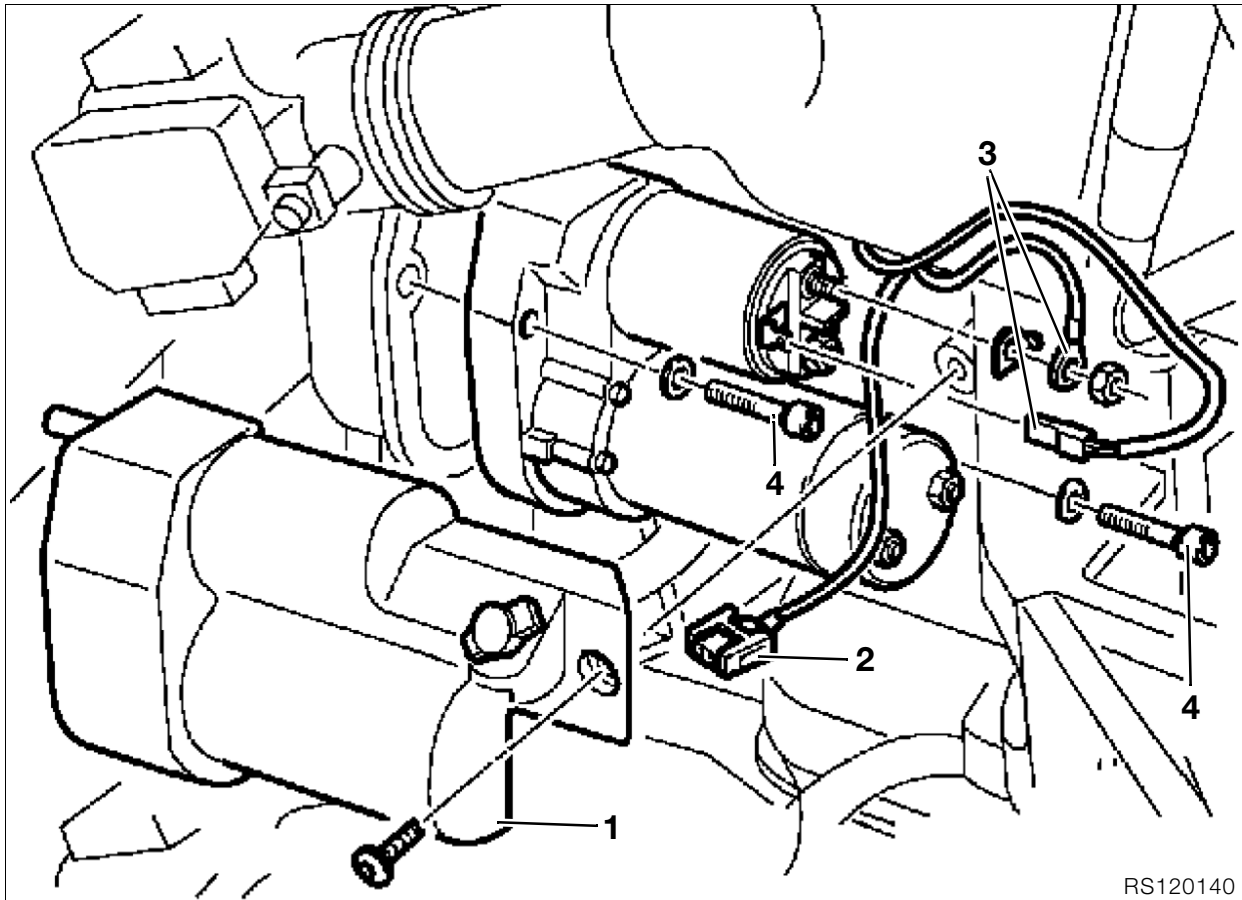

RS120140

Removing and installing starter motor

- Remove the seat.



Caution:

Disconnect earth (ground) lead from battery.
Insulate earth (ground) lead.

- Remove cover (1) for the starter motor and disconnect cable (2) for the power socket.
- Disconnect lead (3).
- Remove securing screws (4) and remove the starter.
- Installation is the reverse of the removal procedure.
- Switch on the ignition.
- Without starting the engine, fully open the throttle once or twice so that the Motronic control unit can register the throttle-valve positions.



Note:

Disconnecting the battery deletes all entries (e.g. faults, settings) stored in the Motronic control unit's memory.

Loss of settings can temporarily impair the operating characteristics when the engine is restarted.



Tightening torque:

Starter motor to engine 20 Nm
 Starter motor cover to gearbox housing 7 Nm
 Positive lead to starter motor 10 Nm

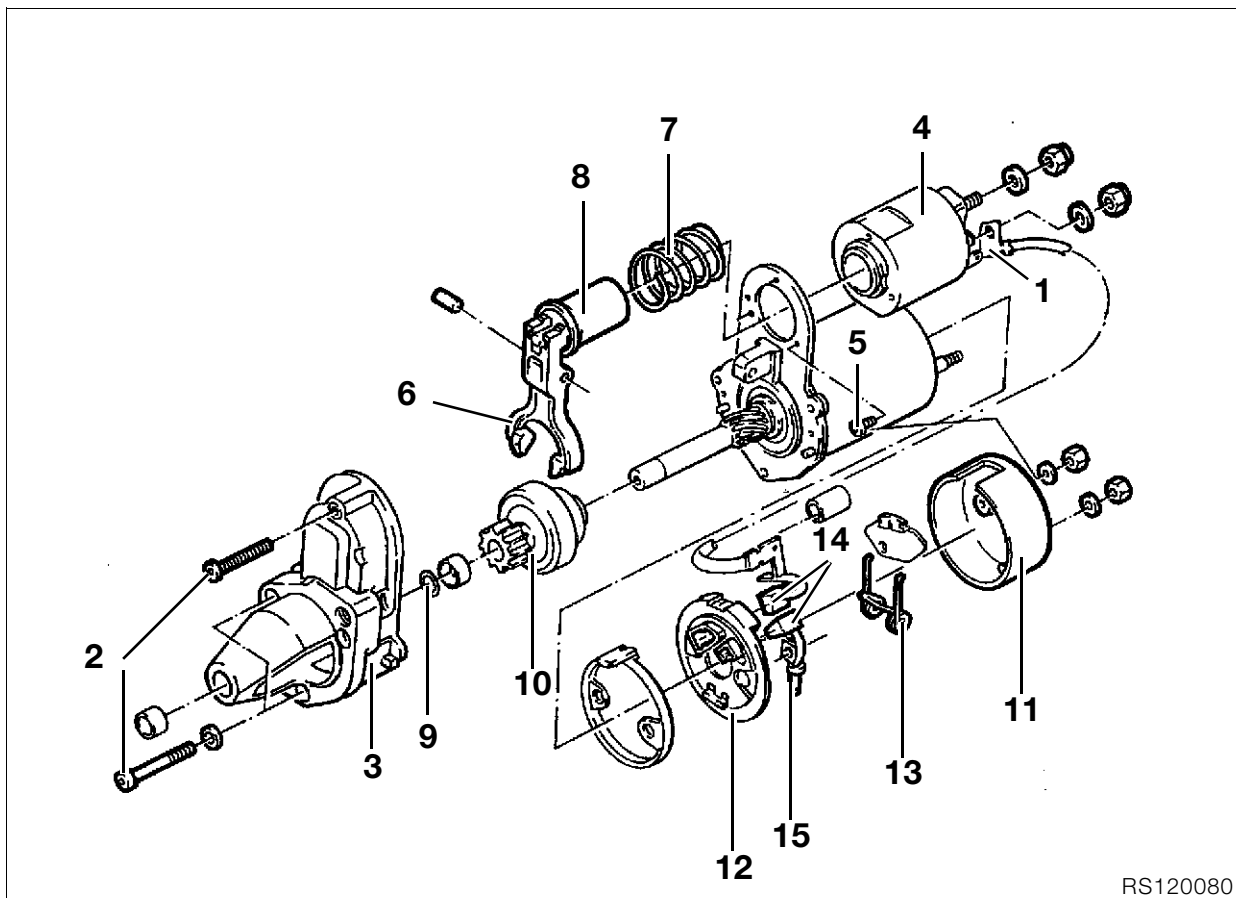
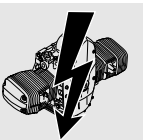

RS120080

Disassembling/assembling starter motor

- Disconnect leads (1).
- Remove securing screws (2).
- Remove flange (3).
- Remove solenoid switch (4) after taking out the retaining screws (5).
- Remove release lever (6) and spring (7) from solenoid switch (8).
- Fit a socket of correct size, tap it lightly to back off the bush and remove the retaining ring (9).
- Remove the starter gear (10) from the shaft.
- Installation is the reverse of the removal procedure.
- Coat the Bendix gear and pull-in ring with grease.

Lubricant: Bosch PZ 2 V 3 silicone grease or equivalent

Replacing carbon brushes

- Disconnect leads (1).
- Remove cover (11).
- Remove holder (12) for carbon brushes.
- Lift up retaining springs (13) and remove carbon brushes (14).
- Install carbon brushes with retaining plate.
- Slide short lead (15) on to threaded pin.
- Install cover (11).
- Connect lead (1).

Checking starter motor

- Test with **BMW** MoDiTeC.

Checking starter relay

- Test with **BMW** MoDiTeC.

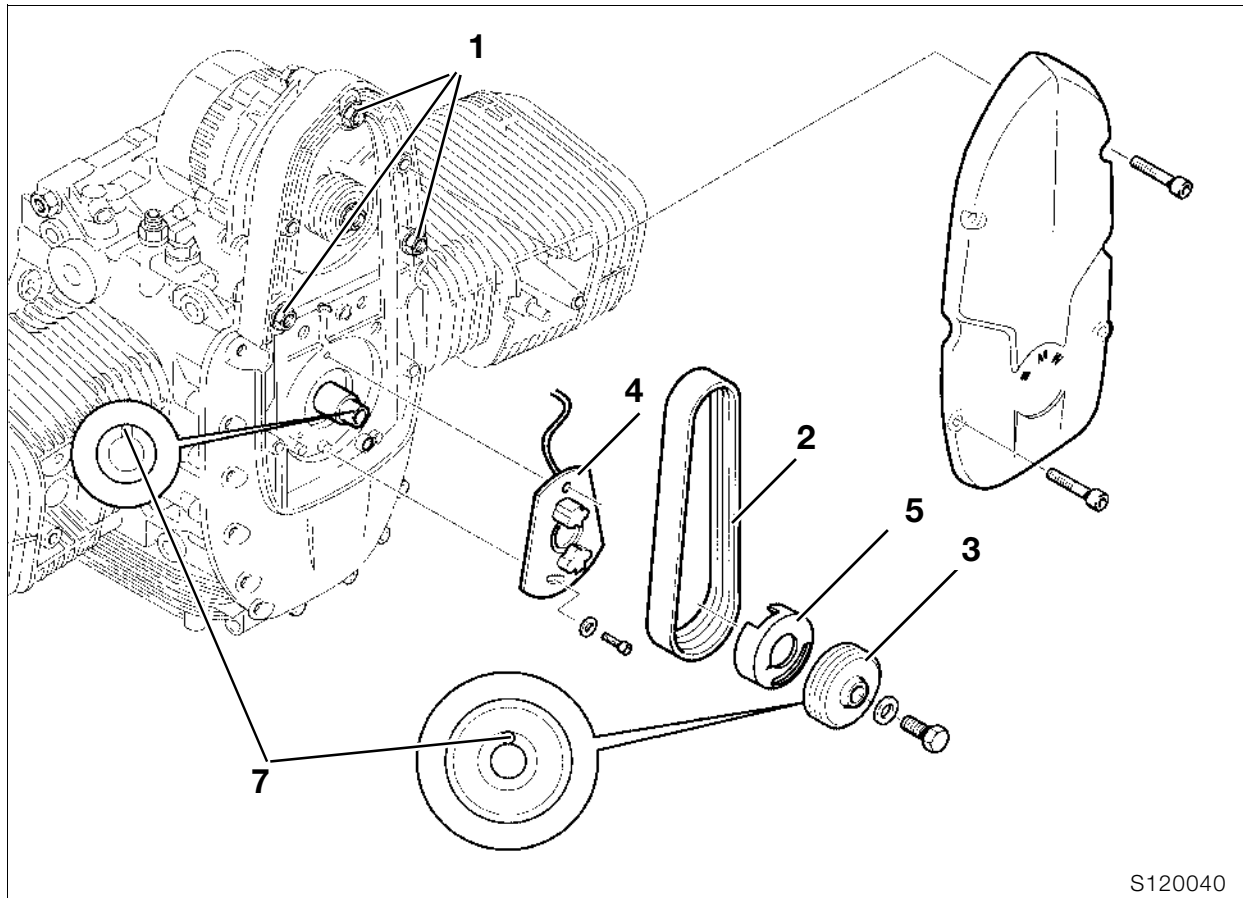

S120040

Removing and installing magnetic gate

- Remove the seat.
- Disengage fuel tank.
- Pull fuel tank to the rear and support it at the front with a piece of wood or similar.

Caution:

Avoid scratching components, for instance by inserting a piece of cloth between the fuel tank and the frame.

- Remove front cover from engine.
- Remove alternator fasteners (1).
- Remove Poly-V belt (2).

Caution:

Disconnect ground (earth) lead from battery. Insulate the ground (earth) lead.

- Remove the starter motor.
- Install locking device, **BMW No. 11 5 640**, to lock clutch housing.
- Remove Poly-V belt pulley (3) with rotor gate from crankshaft.
- Disconnect plug of magnetic gate.

Note:

If necessary, mark position of magnetic gate for re-installation.

- Remove magnetic gate (4).
- Installation is the reverse of the removal procedure.

- Affix rotor (5) of Hall-effect gate with adhesive to the Poly-V belt pulley (3).

Adhesive: Loctite instant adhesive or equivalent

Caution:

Seat retainer for Hall-effect gate rotor in groove in crankshaft (7). Carefully route cable for magnetic gate. Tension Poly-V belt to specification.

- Switch on the ignition.
- Without starting the engine, fully open the throttle once or twice so that the Motronic control unit can register the throttle-valve positions.

Note:

Disconnecting the battery deletes all entries (e.g. faults, settings) stored in the Motronic control unit's memory. Loss of settings can temporarily impair the operating characteristics when the engine is restarted.

Tightening torque:

Preload of Poly-V belt 8 Nm
 Alternator
 to alternator mount cover 20 Nm
 Belt pulley to crankshaft 50 Nm

Timing the ignition

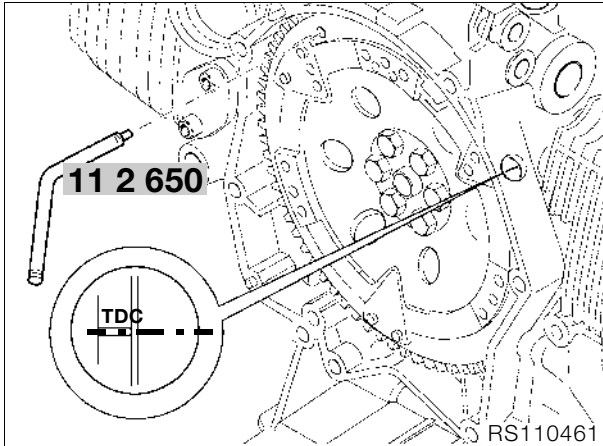

- Using TDC locating pin, **BMW No. 11 2 650**, lock the clutch housing.
- Connect **BMW** MoDiTeC with adapter cable to Hall-effect gate plate.
- Set the timing, following the tester instructions.

13 Fuel preparation and control

Contents

Page

Technical Data	3
Removing and installing air filter housing	5
Removing and installing throttle-valve stub pipe	6
Removing and installing throttle-valve potentiometer	7
Removing and installing Motronic control unit	7

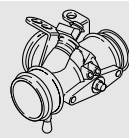

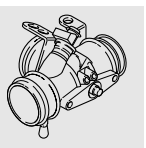

Technical Data	R 1150 GS
Fuel grade	Super (premium), unleaded. 95 octane (RON)
Mixture preparation	Motronic MA 2.4
Throttle stub pipe intl. dia.	mm (in) 45 (1.771)
Throttle angle in rest position	° 5
Air filter	Round paper element

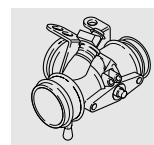

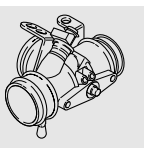

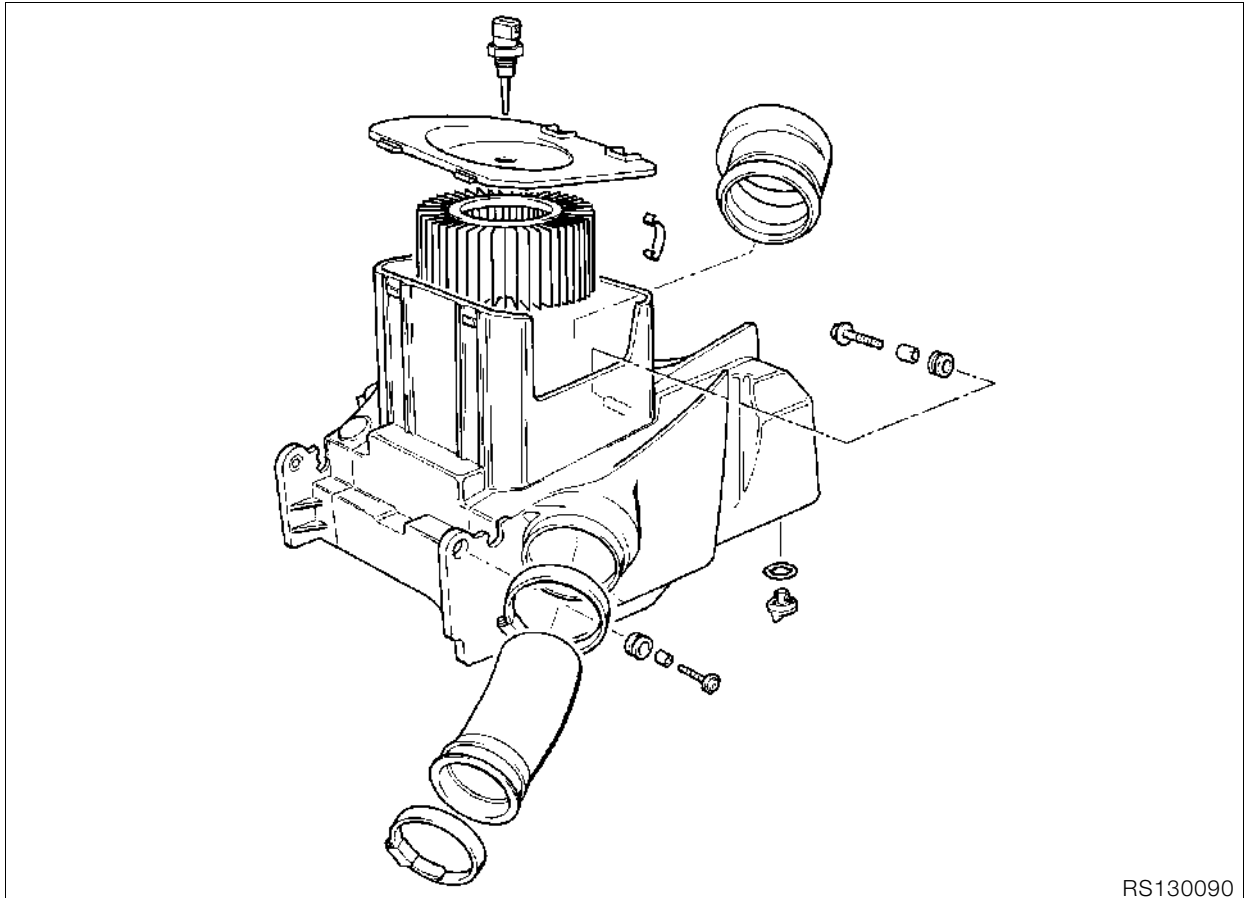

Removing and installing air filter housing

- ➔ Preparatory work.....
See Group 23 (removal of transmission)

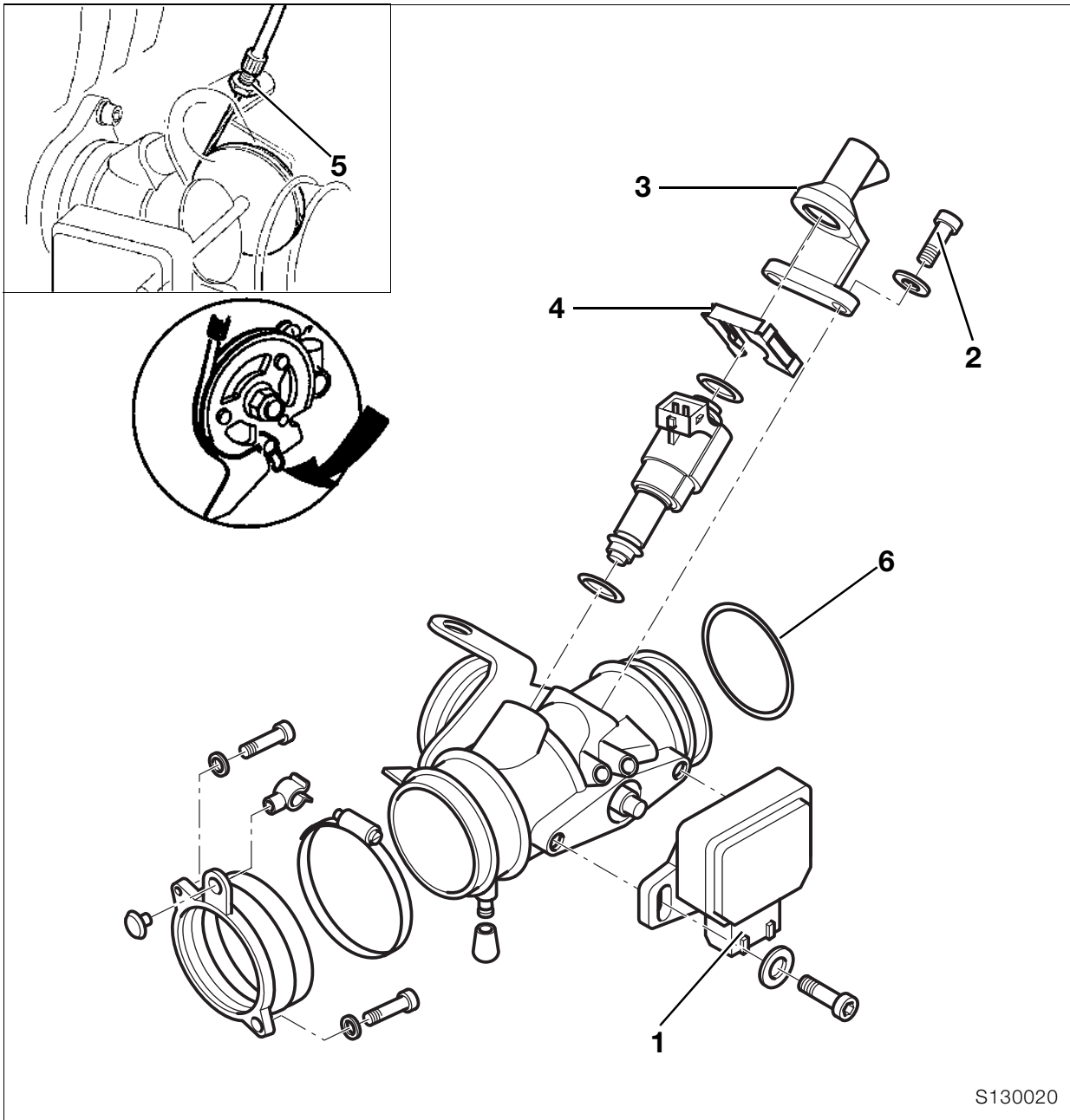

S130020

Removing and installing throttle-valve stub pipe

- Press in spring keeper of multi-pin plug for throttle-valve potentiometer (1) and disconnect plug.



Note:

Do not remove throttle-valve potentiometer unless due for replacement (basic setting is necessary – see Motronic diagnosis instructions).

- Remove screws (2).
- Remove holder (3) with fuel line and injector.
- Remove fuel injector, if necessary.
- Press in the spring catch at the injector plug and pull off the plug.
- Remove locking device (4) from the injector.
- Slacken hose clamps.

- Push intake neck into air filter box and remove throttle-valve stub.
- Disengage throttle cables (5) from right and left throttle-valve stubs.
- Installation is the reverse of the removal procedure.



Caution:

Make sure that O-ring (6) on throttle-valve stub is in perfect condition.

Adjusting speed increase, idle speed and synchronisation

➡ See Group 00

Removing and installing throttle-valve potentiometer

- Press in spring keeper of multi-pin plug for throttle-valve potentiometer (1) and disconnect plug.



Note:

Do not remove throttle-valve potentiometer unless due for replacement (basic setting is necessary – see Motronic diagnosis instructions).

- Remove the throttle-valve potentiometer.
- Adjust throttle-valve potentiometer with **BMW** MoDiTeC after installing.
- Mark screws with a paint spot.

Removing and installing Motronic control unit

- Remove fuel tank.



Caution:

Switch off ignition; disconnect earth (ground) lead from battery and insulate it.

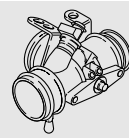
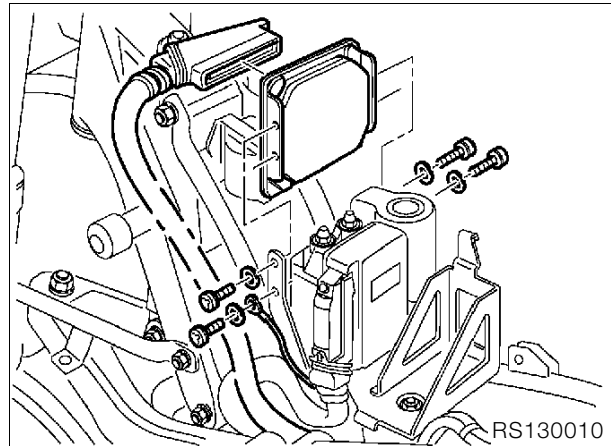

- Disconnect plug from Hall sensor.
- Remove Motronic control unit.
- Remove connector strip.
- Installation is the reverse of the removal procedure.
- Switch on the ignition.
- Without starting the engine, fully open the throttle once or twice so that the Motronic control unit can register the throttle-valve positions.



Note:

Disconnecting the battery deletes all entries (e.g. faults, settings) stored in the Motronic control unit's memory.

Loss of settings can temporarily impair the operating characteristics when the engine is restarted.

16 Fuel tank and lines

Contents	Page
Technical Data	3
Removing and installing fuel tank	5
Removing and installing roll-over valve	6
Removing and installing fuel filter, fuel pump and fuel level sensor	7
Removing and installing fuel filter	7
Removing and installing fuel pump and fuel level sensor	7
Checking fuel pump pressure	7
Removing and installing fuel distributor and pressure regulator	8





Technical Data		R 1150 GS
Fuel tank		
Tank capacity (usable)	l (Imp.gal/ US gal)	22 (4.8/5.81)
Including reserve of	l (Imp.gal/ US gal)	approx. 4 (0.88/1.06)
Fuel pump		
Type		Turbine-wheel pump
Make		VDO type HPI-3.0
Operating voltage	V	7...15V
Fuel pressure	bar (psi)	3±0.2 (42.69±2.85)
Delivery rate	l/h (Imp.gal/ US gal/h)	110 (at 12V) (24.21/29.06)





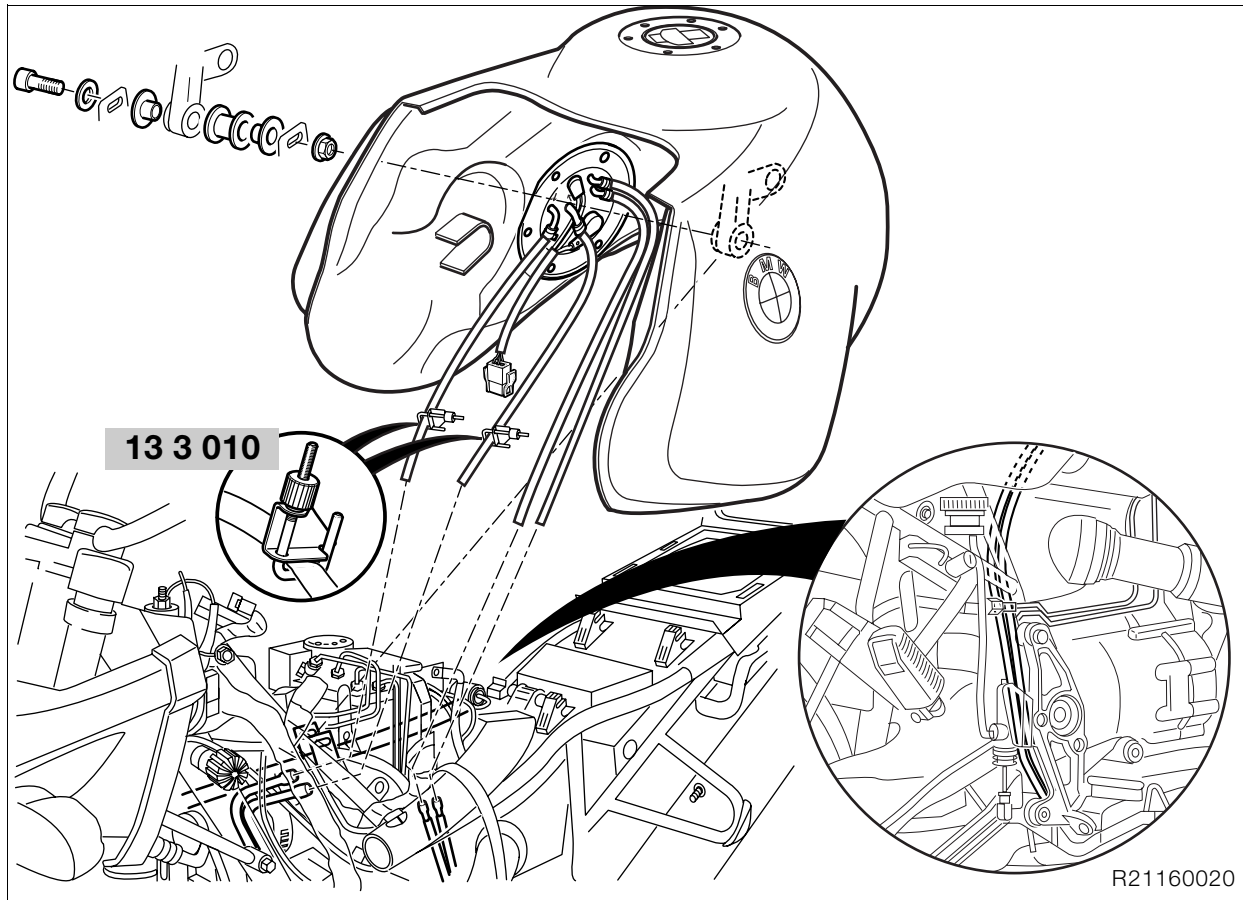

Removing and installing fuel tank

- Remove the seat.
- Remove side panel.
- Remove screw securing fuel tank.
- Seal the fuel feed and return lines with hose clips, **BMW No. 13 3 010**, and disconnect.
- Disconnect breather and overflow hoses.
- Disconnect the plug of the fuel pump.
- Remove fuel tank.
- Installation is the reverse of the removal procedure.

 **Tightening torque:**
 Fuel tank to rear frame 22 Nm

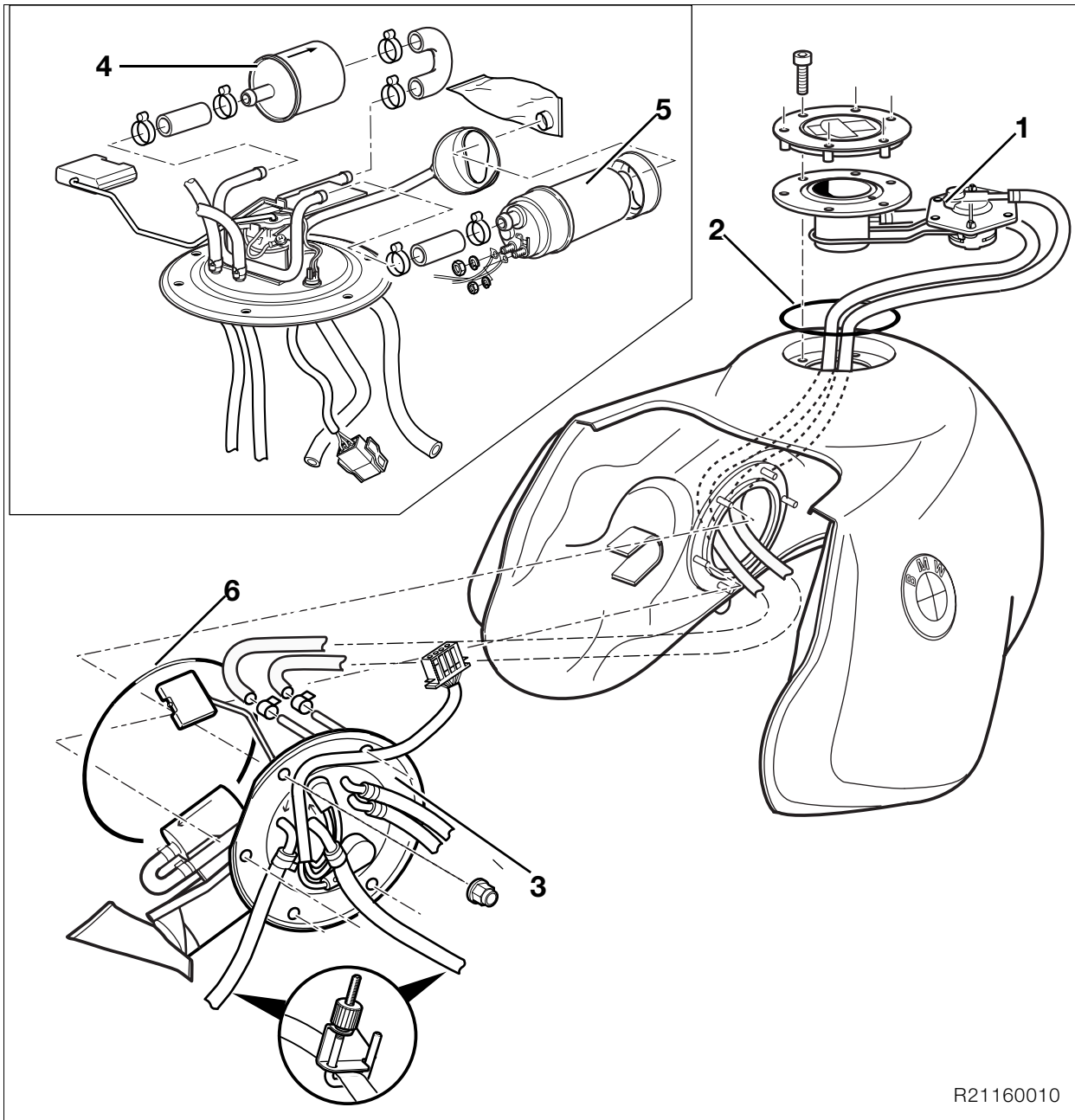

Removing and installing roll-over valve

⚠ Caution:

Fuel is flammable and a hazard to health. Observe relevant safety regulations.

- Drain fuel tank, if necessary.
- Remove the fuel filler cap.
- Remove the reducer unit with roll-over valve (1) and disconnect the hoses.
- Remove the roll-over valve.
- Installation is the reverse of the removal procedure.
- Secure non-reusable hose clips with pliers, **BMW No. 13 1 500**.

⚠ Caution:

Make sure that O-ring seal (2) is correctly seated. After installing, check fuel filler cap for leaks.

Removing and installing fuel filter, fuel pump and fuel level sensor



Caution:

Fuel is flammable and a hazard to health. Observe relevant safety regulations.

- Drain fuel tank.
- Remove fuel pump unit (3) and disconnect hoses.

Removing and installing fuel filter

- Release hose clips at fuel filter (4).



Caution:

Note correct direction of flow through fuel filter.

- Remove/install fuel filter.
- Secure non-reusable hose clips with pliers, **BMW No. 13 1 500**.

Removing and installing fuel pump and fuel level sensor

- Disconnect the electrical connections at the fuel pump (5).
- Release the hose clip at the fuel pump.
- Remove fuel pump.
- Installation is the reverse of the removal procedure.
- Secure non-reusable hose clips with pliers, **BMW No. 13 1 500**.



Caution:

Make sure O-ring (6) is in perfect condition. After installing, check fuel pump unit for leaks.



Tightening torque:

Fuel pump assembly to tank..... 5 Nm

Checking fuel pump pressure

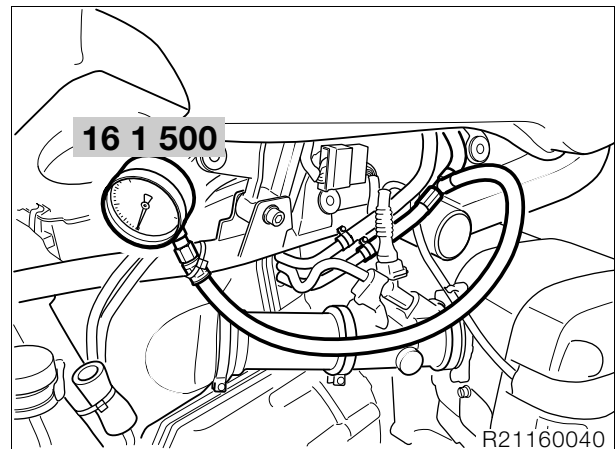

- Connect test pressure gauge, **BMW No. 16 1 500**, on the pressure side.
- Start engine and allow to idle.

Fuel pressure:

Specification 3 ± 0.2 bar (42.69 ± 2.85 psi)



Note:

If fuel pressure is low, check pump, fuel filter, pressure regulator and fuel line.



Removing and installing fuel distributor and pressure regulator

- Remove air filter box.
- ⇒See Group 23, removing transmission.

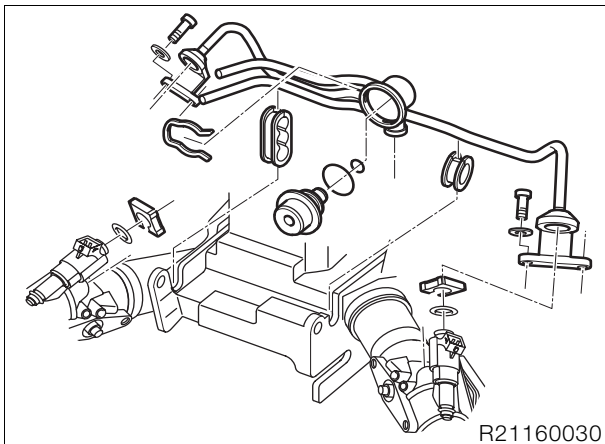

- Remove the fuel distributor with pressure regulator from the holder.
- Installation is the reverse of the removal procedure.



18 Exhaust system

Contents

Page

Removing and installing exhaust system	3
Removing and installing silencer and front silencer	3
Removing silencer end cap and silencer guard	3
Installing silencer end cap and silencer guard	3
Removing and installing exhaust manifolds	4



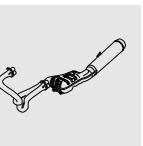

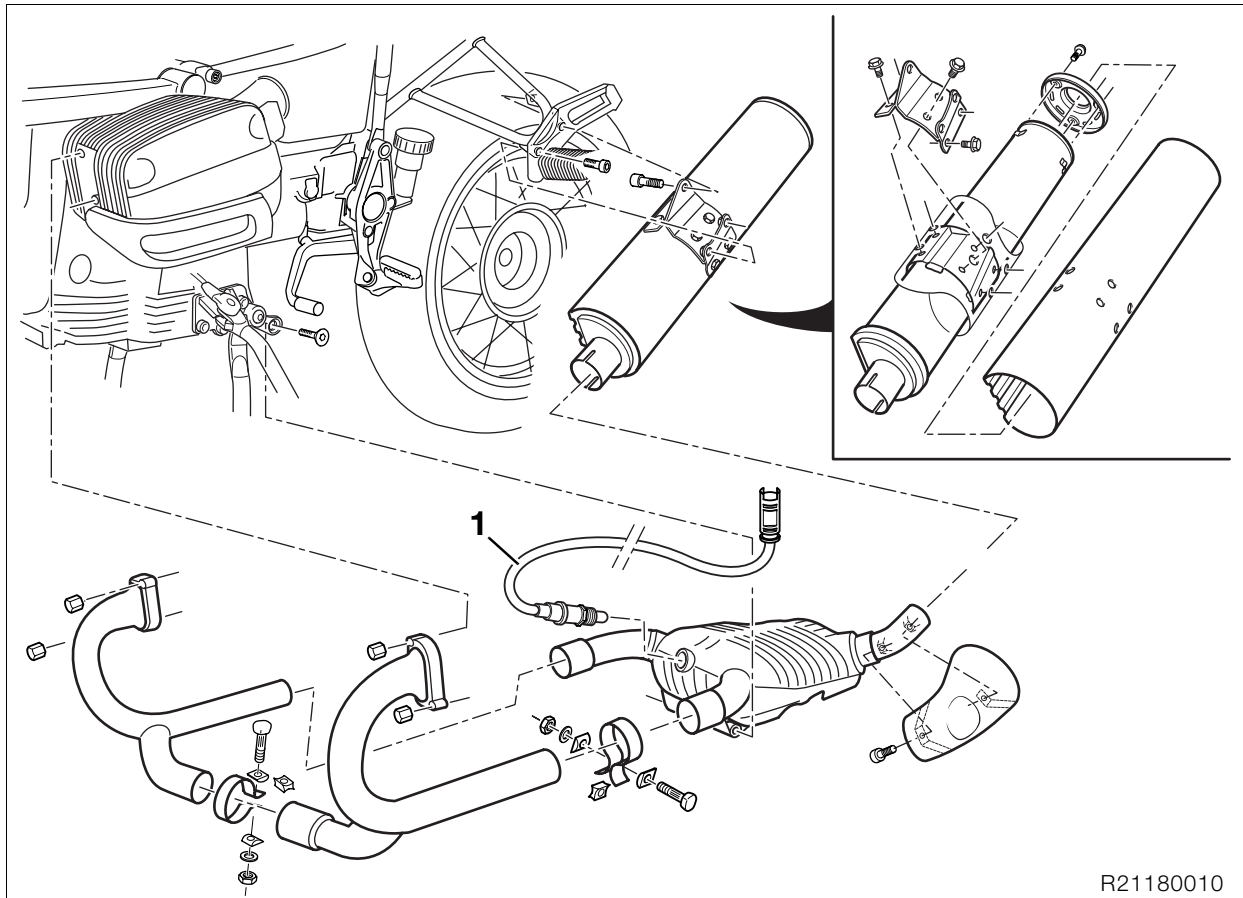

R21180010

Removing and installing exhaust system

Removing and installing silencer and front silencer

- Remove rear silencer.
- Disengage fuel tank and pull to the rear.

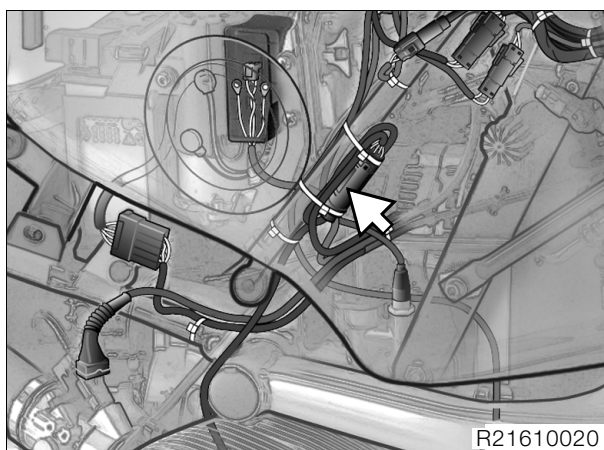

R21610020

- Disconnect the oxygen-sensor plug and remove the cable holders.

Caution:

Do not pull the oxygen sensor cable.

- Slacken the clamps holding the front silencer.
- Remove front silencer.

- If necessary, remove/install oxygen sensor (1).
- Installation is the reverse of the removal procedure.
- Secure the oxygen sensor with special socket wrench insert, **BMW No. 11 7 020**.

Removing silencer end cap and silencer guard

- Remove end cap.
- Remove fasteners securing silencer bracket.
- Remove silencer guard from silencer.

Installing silencer end cap and silencer guard

- Push silencer guard onto silencer.
- Install end cap and secure with oiled serrated-head screws.
- Slide the silencer guard against the end cap and tighten the fasteners of the silencer bracket.

Tightening torque:

Clamp, manifold to front silencer (apply Optimoly TA to clamp seat).....	45 Nm
Oxygen sensor (grease with Optimoly TA).....	45 Nm
Front silencer to main-stand link	20 Nm
Mounting bracket to silencer (threads oiled)	15 Nm
Silencer to rear frame.....	35 Nm
Guard to silencer (threads oiled)	8 Nm

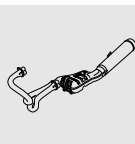

Removing and installing exhaust manifolds

- Slacken the clamp holding the front silencer.
- Remove fasteners securing exhaust manifold.
- Remove exhaust manifold.
- Installation is the reverse of the removal procedure.



Caution:

After a trial run, read out Motronic fault memory.
Note position of wiring for oxygen sensor.



Tightening torque:

Clamp, manifold to front silencer
(apply Never Seize to clamp seat) 45 Nm
Exhaust manifold to cylinder head 21 Nm

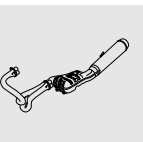

21 Clutch

Contents

Page

Technical Data	3
Removing and installing clutch	5
Removing clutch	5
Removing clutch from vehicle	5
Removing clutch from engine	7
Installing clutch	7
Installing clutch in engine	7
Installing clutch in vehicle	7
Removing and installing clutch hydraulic line	8
Removing and installing clutch slave cylinder	8
Filling/bleeding clutch line	9





Technical Data		R 1150 GS
Type of clutch		Single dry plate with increased-leverage diaphragm spring
Actuation		Hydraulic, with master and slave cylinders
Master cylinder piston dia.	mm (in)	13 (0.51)
Slave cylinder piston dia.	mm (in)	24 (0.94)
Clutch fluid		DOT 4 brake fluid
Clutch plate dia.	mm (in)	165 (6.50)
Wear dimension	mm (in)	4.8 (0.18) (measured with tips of calipers pressed by hand against rivets of clutch plate).

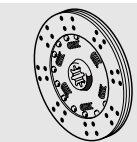

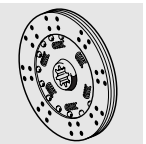

Removing and installing clutch

Removing clutch

Removing clutch from vehicle

- Remove the sump guard.
- Secure stand, **BMW No. 00 1 520**, to motorcycle with overlength bushes and screws, **BMW No. 00 1 527**.



Note:

Mount a washer on the screw on the right as viewed in the forward direction of travel. Depth of thread in tapped bore has been reduced!

- Remove the seat.
- Remove side panel.
- Remove fuel tank fastener.

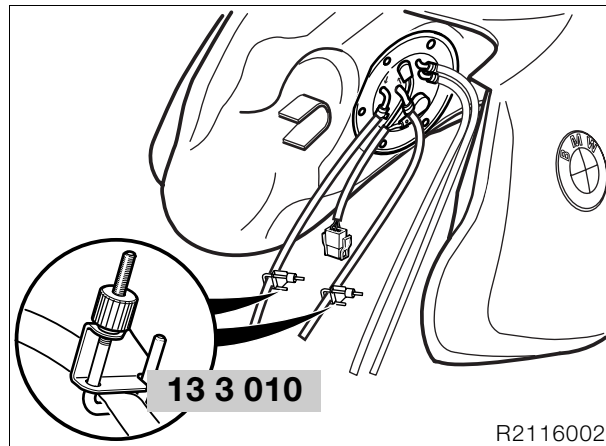

Caution:

Fuel is flammable and a hazard to health. Observe relevant safety regulations.

- Seal the fuel feed and return lines with hose clips, **BMW No. 13 3 010**, and disconnect.
- Disconnect breather lines.
- Disconnect plug of fuel pump unit.
- Remove fuel tank.
- Remove the battery.



Caution:

Disconnect the negative battery terminal first, then the positive terminal. Connect the positive battery terminal first, then the negative terminal.

- Unscrew rear battery mount.
- Disconnect the air temperature sensor plug.
- Disconnect the diagnostic plug.
- Remove air filter cover.
- Remove the air filter.
- Remove the intake air pipe.
- Unfasten air filter box at front and rear.
- Disconnect plug/oxygen sensor and remove cable.
- Disconnect hose clamps/throttle stub pipes and push the stubs into the air filter box.
- Disconnect plugs of injection valves.
- Remove holders of injection valves.

- Remove injection valves from throttle stub pipes.
- Loosen the fasteners securing the right and left footrest plates.
- Remove top screws on left and right.



Note:

When installing the footrest plates, use the long screws on the right and the short screws on the left.

- Remove rear-frame fasteners on left and right at front, but only loosen strut fasteners.
- Remove rear silencer.
- Remove front silencer.
- Remove starter motor cover and disconnect cable to power socket.
- Disconnect cables from starter motor.
- Remove the starter motor.
- Disconnect cable from oil pressure switch.
- Disconnect plug of side-stand switch.
- Disconnect plug of gear indicator.
- Remove the fastener securing the rear spring strut at the bottom.
- Remove hydraulic spring adjuster.
- Disconnect plug of brake light switch and remove cable.
- Remove brake master cylinder and guard from footrest plate.
- Remove rear brake fluid reservoir from its holder.
- Remove brake line from rear frame.
- Remove brake line from swinging arm.
- **[ABS]** Disconnect the plug of the rear ABS sensor.
- **[ABS]** Remove the rear ABS sensor.
- Remove rear brake caliper.
- Use cable ties to secure the brake caliper to the rear frame.
- Remove the clutch bleeding/filler adapter from the rear frame.

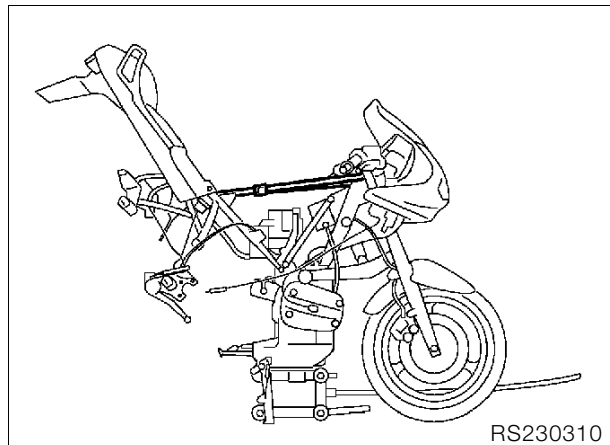

- Tilt the rear frame up and secure it in this position with a strap attached to the handlebar.
- Remove cable ties/wiring harness from air filter box.

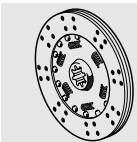

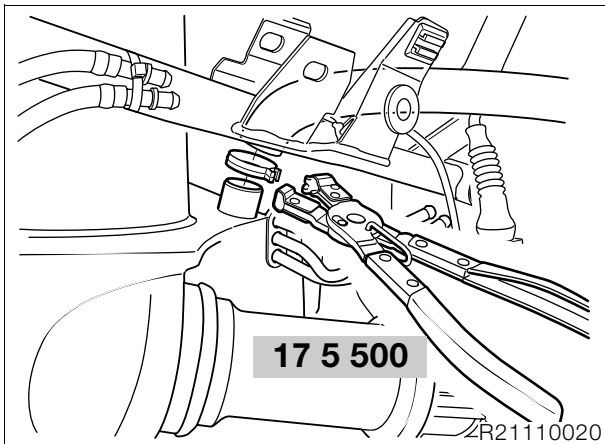

- Use hose clip pliers, **BMW No. 17 5 500**, to disconnect hose from rotary breather from air-filter box.
- Remove air filter box.
- Remove the fuel distributor.
- Remove clutch slave cylinder.
- Remove the gearbox.

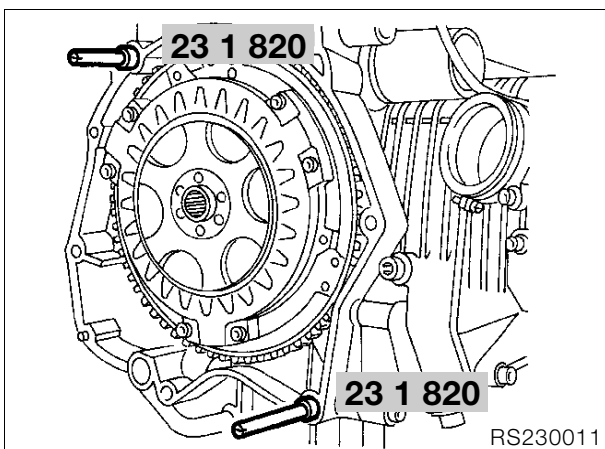

- Always use oiled guide pins, **BMW No. 23 1 820**, when removing or installing the gearbox.
- Remove the rear wheel, rear wheel drive and swinging arm together with the gearbox.

⚠ Caution:

Take care to keep the gearbox at its installed height until the full length of the clutch actuating rod is visible, as otherwise the rod can be bent.

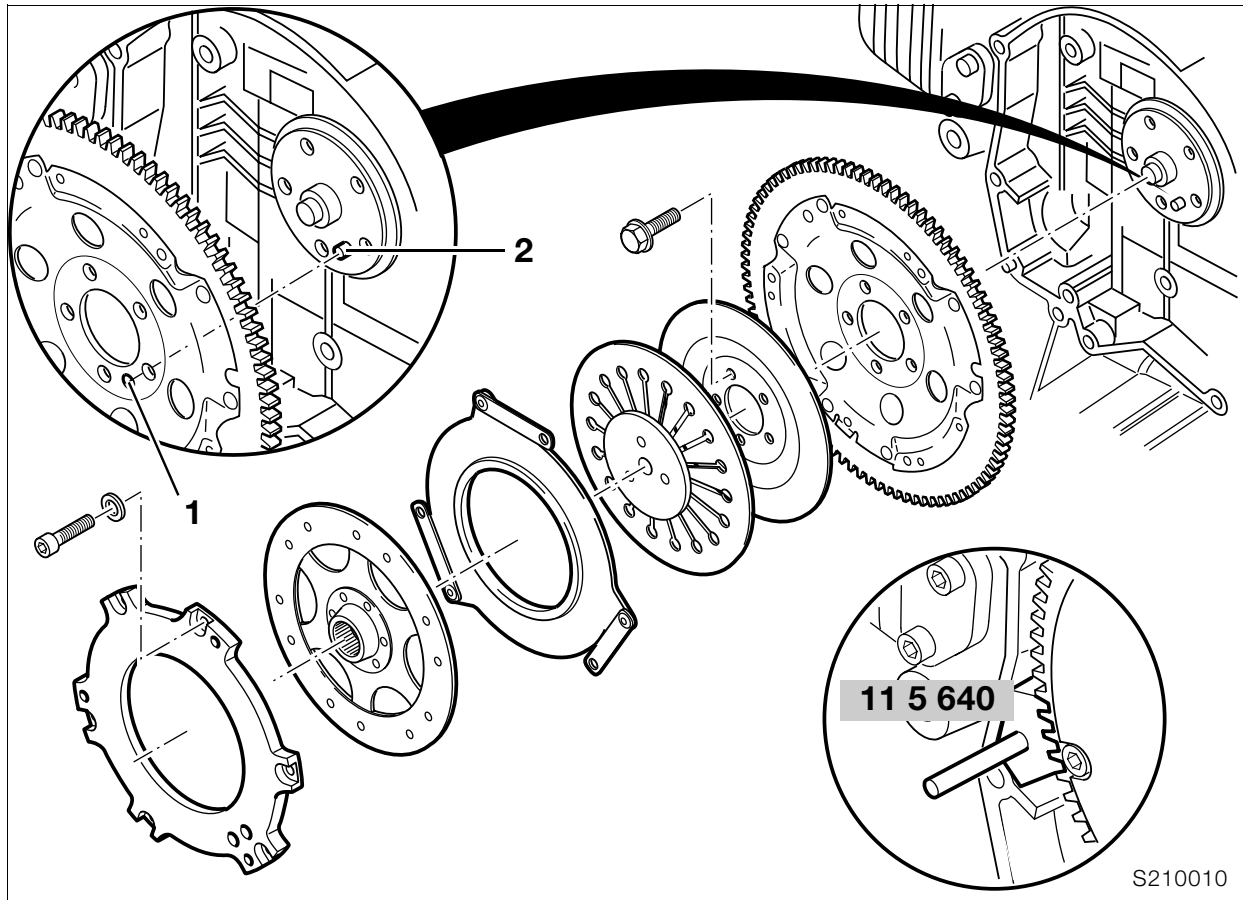

Removing clutch from engine

- Lock the clutch housing with special tool, **BMW No. 11 5 640**.
- Remove the clutch.

Installing clutch

Installing clutch in engine

- Install clutch housing with crankshaft pin (2) located in bore (1).
- Install locking device, **BMW No. 11 5 640**, to lock clutch housing.

Caution:

Always use new screws for housing and cover.

- Insert all screws by hand and tighten.

Tightening torque:

Clutch housing to crankshaft
(screw threads lightly oiled)
Initial torque 40 Nm
Tightening angle..... 32°

- Install clutch.

Caution:

Make sure that colour marks on the clutch housing, thrust plate and housing cover are offset 120°.

- Secure the clutch with the retaining screws.
- Center the clutch plate with centering pin, **BMW No. 21 2 673**.
- Tighten retaining screws in diagonally opposite sequence.

Lubrication points:

Splines on clutch plate and gearbox input shaft.
Diaphragm spring contact surface on clutch housing.
Diaphragm spring contact surface on pressure plate.

..... Optimoly MP3 paste

Tightening torque:

Housing cover to flywheel 12 Nm

Installing clutch in vehicle

- Installation is the reverse of the removal procedure.

Note:

When installing, fit a new seal on the clutch slave cylinder.

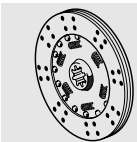

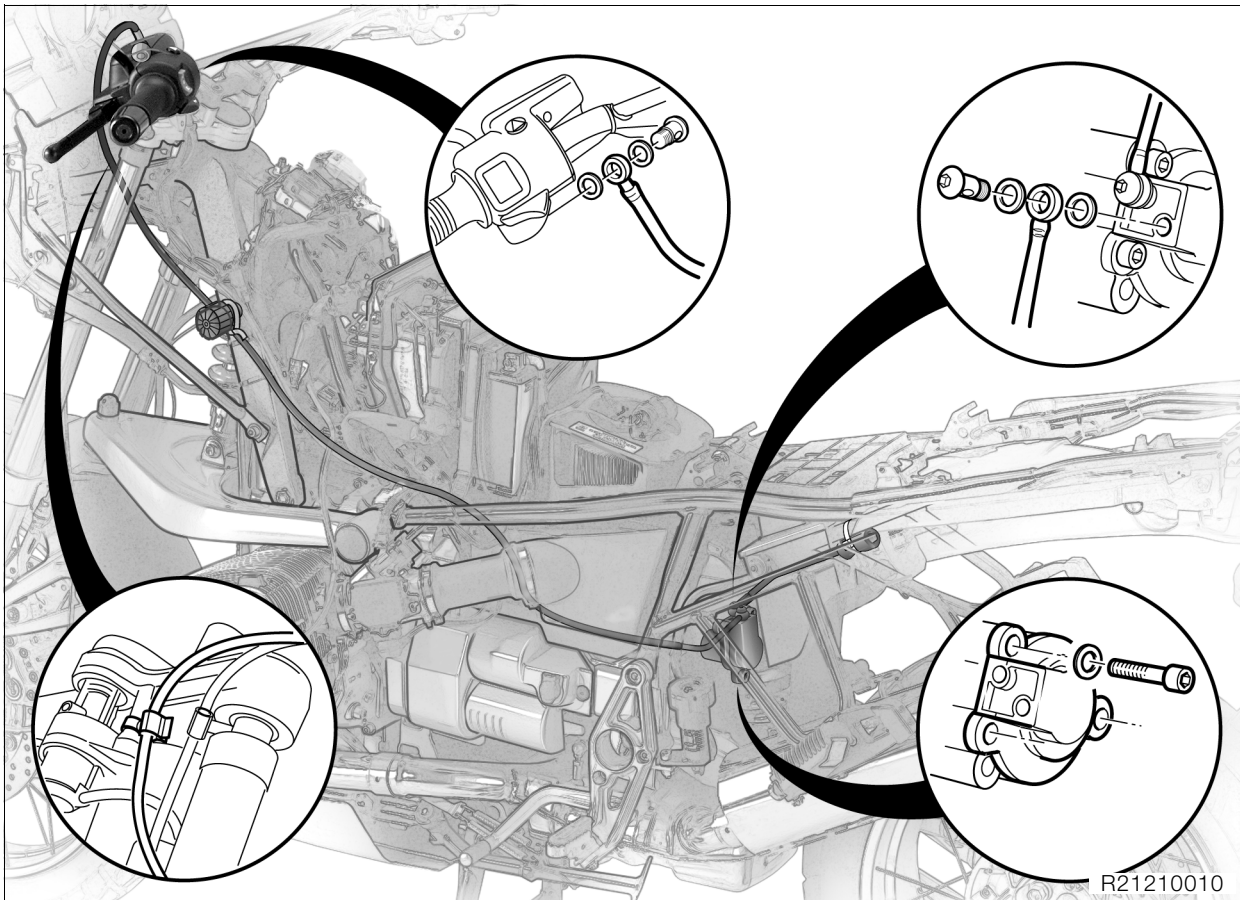

Removing and installing clutch hydraulic line

- Remove the seat.
- Remove fuel tank.
- Remove rear brake caliper.
- Remove rear wheel.
- Remove suspension strut.
- Drain the clutch operating system.

Caution:

Do not allow brake fluid to come into contact with painted parts of the motorcycle as brake fluid destroys paint.

- Remove central electrics box from rear frame.
- Remove the silencer from the rear frame.
- Remove the bracket for the brake line from the rear frame.
- Remove brake fluid reservoir from its holder.
- Remove fasteners securing rear frame and raise it approx. 15 mm (0.59 in), pivoting on the fastener for the footrest plate.
- Disconnect line from master cylinder.
- Disconnect the lines from the clutch slave cylinder.
- Remove clutch line.
- Installation is the reverse of the removal procedure.
- Fill the clutch operating system.

Note:

When installing, fit new sealing rings.

Tightening torque:

Clutch line to handlebar fitting 14 Nm

Removing and installing clutch slave cylinder

- Remove the seat.
- Remove rear brake caliper.
- Remove rear wheel.
- Remove suspension strut.
- Drain the clutch operating system.

Caution:

Do not allow brake fluid to come into contact with painted parts of the motorcycle as brake fluid destroys paint.

- Remove central electrics box from rear frame.
- Remove the silencer from the rear frame.
- Remove the bracket for the brake line from the rear frame.
- Remove brake fluid reservoir from its holder.
- Remove fasteners securing rear frame and raise it approx. 15 mm, pivoting on the fastener for the footrest plate.
- Disconnect the lines from the clutch slave cylinder.
- Remove clutch slave cylinder.
- Installation is the reverse of the removal procedure.

Note:

The frame tube has to be removed so that the clutch slave cylinder can be tightened to the correct torque.

When installing, fit new sealing rings.

- Fill the clutch operating system.

Filling/bleeding clutch line



Tightening torque:

Clutch slave cylinder to gearbox 9 Nm ➡ See Group 00

Tightening sequence:

Connecting pipe/gearbox

1. to gearbox and left footrest plate
(clean thread + Loctite 243)..... 42 Nm
2. clamp block, connecting tube to gearbox .. 9 Nm
3. to gearbox and right footrest plate
(clean thread + Loctite 243)..... 42 Nm



23 Transmission

Contents

Page

Technical Data	3
Gearbox - sectional drawing	5
Removing and installing gear-shift lever	7
Removing/installing gearbox	7
Replacing the shaft sealing rings in the gearbox housing and gearbox cover ...	9
Replacing the input shaft sealing ring at input end	9
Replacing output shaft sealing ring	9
Replacing input shaft sealing ring at output end	10
Replacing shaft sealing ring for selector drum	10
Replacing sealing ring for selector shaft	10
Disassembling gearbox	11
Removing gearbox housing	11
Removing selector drum	12
Disassembling/assembling selector shaft	12
Removing gearbox shafts	13
Replacing grooved ball bearings of intermediate shaft	13
Disassembling/assembling input shaft	14
Disassembling input shaft	14
Assembling input shaft/checking and adjusting axial play of spring cluster	15
Disassembling/reassembling output shaft	16
Disassembling output shaft	16
Assembling output shaft	17
Checking endplay	18
Checking/adjusting fully assembled length of gearbox shafts and selector drum	19
Checking/adjusting fully-assembled length of intermediate shaft	19
Checking/adjusting fully-assembled length of output shaft	20
Checking/adjusting fully-assembled length of input shaft	21
Checking/adjusting fully assembled length of selector drum	22
Shimming selector shaft	23



Contents

Page

Assembling gearbox	23
Installing input, output and intermediate shafts	24
Installing selector shaft	25
Installing selector drum	25
Installing gearbox housing	26

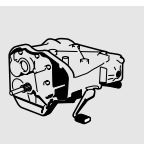

Technical Data		R 1150 GS
Type of gearbox		6-speed gearbox with claw-action shift and integral reaction damper for all gears
Gear shift type		Foot-operated lever and selector drum with over-shoot detent
Gear ratios		
1st gear		3.864
2nd gear		3.022
3rd gear		2.393
4th gear		1.962
5th gear		1.700
6th gear		1.316
Oil grade (all the year round)		Brand-name SAE 90 hypoid gear oil, API Class GL 5
Capacity	l (Imp.pint/ US quart)	approx. 1.0 (1.76/1.06) (to lower edge of filler screw)
Endplay of spring segment at input shaft	mm (in)	0.4 ... 0.6 (0.0157 ... 0.0236)
Endplay at 1st gear, output shaft	mm (in)	0.1 ... 0.33 (0.0039 ... 0.0130)
Endplay at 2nd gear, output shaft	mm (in)	0.1 ... 0.33 (0.0039 ... 0.0130)
Endplay, 3rd/4th gear (total play) output shaft	mm (in)	0.1 ... 0.67 (0.0039 ... 0.0264)
Selector shaft endplay	mm (in)	0.1 ... 0.3 (0.0039 ... 0.0118)
Length of selector drum, fully compressed	mm (in)	111.80 ... 111.90 (4.402 ... 4.406)

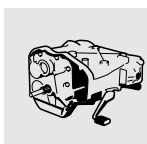

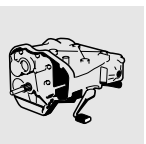

Gearbox - sectional drawing

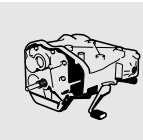
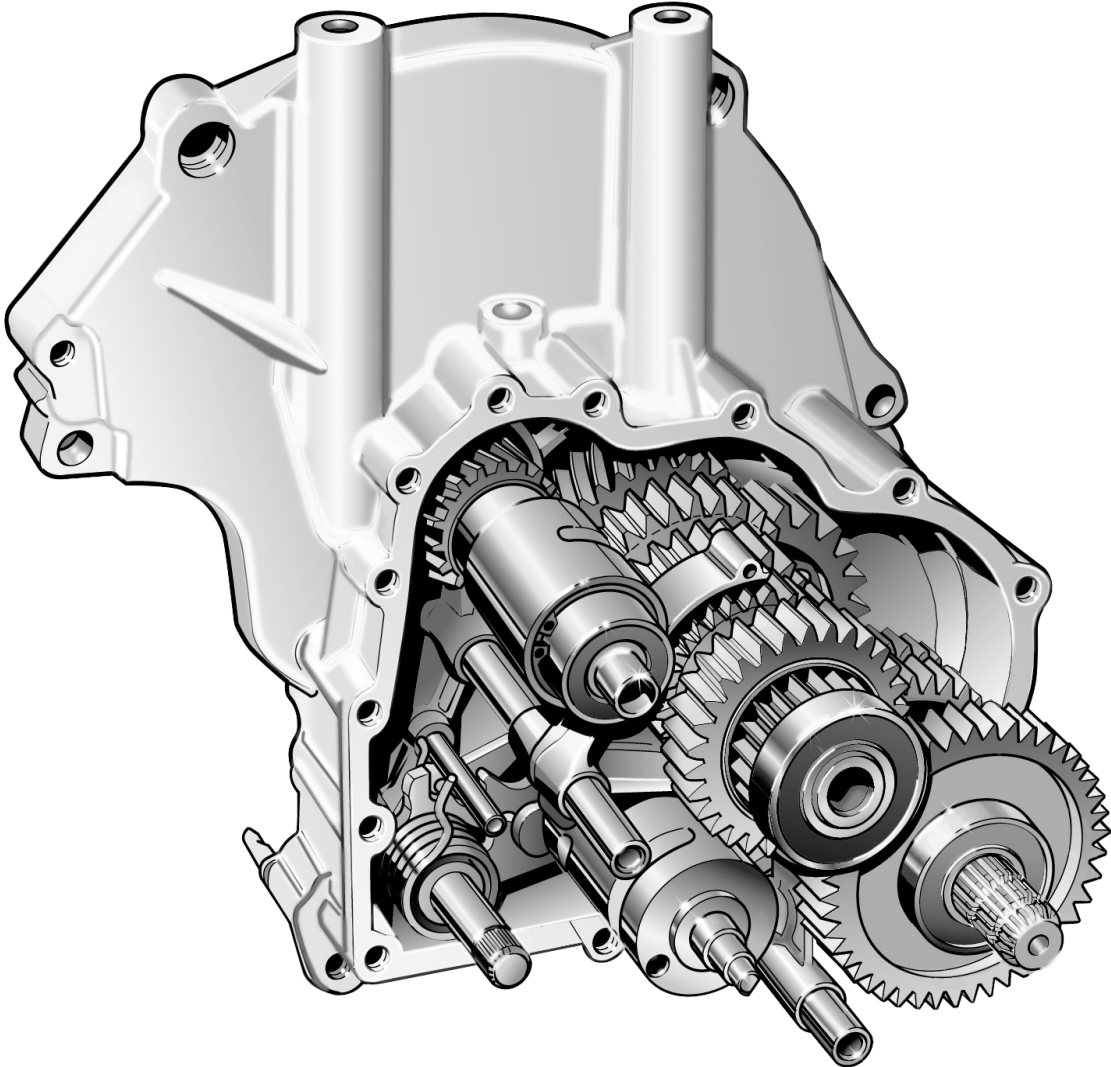

R21239010

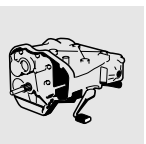

Removing and installing gear-shift lever

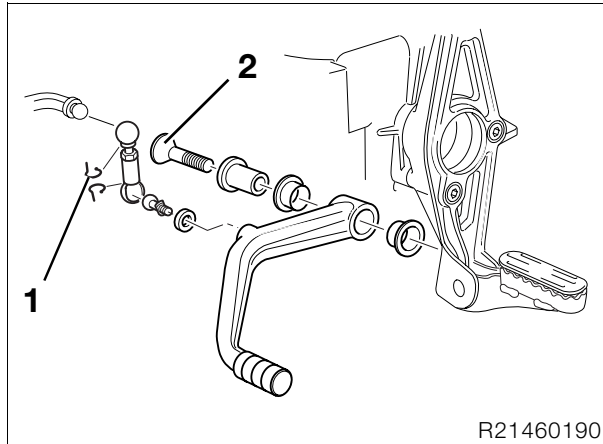

R21460190

- Remove retaining clip (1) and unfasten ball head.
- Remove retaining screw (2) on gear shift pedal.
- Installation is the reverse of the removal procedure.



Tightening torque:

Gear shift pedal to footrest plate 35 Nm

Removing/installing gearbox

- Remove the sump guard.
- Secure stand, **BMW No. 00 1 520**, to motorcycle with overlength bushes and screws, **BMW No. 00 1 527**.



Note:

Mount a washer on the screw on the right as viewed in the forward direction of travel.
Depth of thread in tapped bore has been reduced!

- Remove the seat.
- Remove side panel.
- Disengage fuel tank.



Caution:

Fuel is flammable and a hazard to health. Observe relevant safety regulations.

- Seal the fuel feed and return lines with hose clips, **BMW No. 13 3 010**, and disconnect.
- Disconnect breather lines.
- Disconnect plug of fuel pump unit.
- Remove fuel tank.
- Remove the battery.



Caution:

Disconnect the negative battery terminal first, then the positive terminal. Connect the positive battery terminal first, then the negative terminal.

- Unscrew rear battery mount.

- Disconnect the air temperature sensor plug.
- Disconnect the diagnostic plug.
- Remove air filter cover.
- Remove the air filter.
- Remove the intake air pipe.
- Unfasten air filter box at front and rear.
- Disconnect plug of oxygen sensor and remove cable.
- Disconnect hose clamps/throttle stub pipes and push the stubs into the air filter box.
- Disconnect plugs of injection valves.
- Remove holders of injection valves.
- Remove injection valves from throttle stub pipes.
- Detach retaining clip from ball head/shift linkage and remove ball head.
- Remove rear-frame fasteners on left and right at front, but only loosen strut fasteners.
- Remove manifold.
- Remove rear silencer.
- Remove front silencer.
- Remove starter motor cover and disconnect cable to power socket.
- Disconnect cables from starter motor.
- Remove the starter motor.
- Disconnect cable from oil pressure switch.



R21610050

- Disconnect plug of gear indicator.
- Remove the fastener securing the rear spring strut at the bottom.
- Remove hydraulic spring adjuster.
- Disconnect plug of brake light switch and remove cable.
- Remove brake master cylinder and guard from footrest plate.
- Take off the footrest plates.



Note:

When installing the footrest plates, use the long screws on the right and the short screws on the left.

- Remove rear brake fluid reservoir from its holder.
- Remove brake line from rear frame.
- Remove brake line from swinging arm.



- **[ABS]** Disconnect the plug of the rear ABS sensor.
- **[ABS]** Remove the rear ABS sensor.
- Remove rear brake caliper.
- Use cable ties to secure the brake caliper to the rear frame.
- Remove the clutch bleeding/filler adapter from the rear frame.

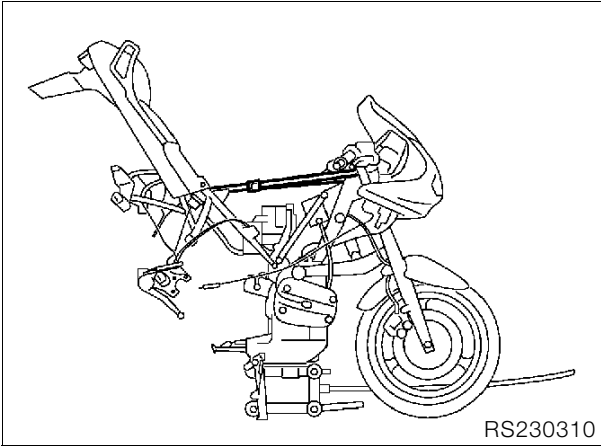

- Tilt the rear frame up and secure it in this position with a strap attached to the handlebar.
- Remove cable ties/wiring harness from air filter box.
- Use hose clip pliers, **BMW No. 17 5 500**, to disconnect hose from rotary breather from air-filter box.
- Remove air filter box.
- Remove the fuel distributor.
- Remove the clutch slave cylinder; fit a new seal when installing.
- Remove rear wheel cover.
- Remove rear wheel.

! Caution:

Support the rear wheel drive.

- Remove fastener securing strut to gearbox.
- Release the retaining strap securing the flexible gaiter to the swinging arm.
- Push the flexible gaiter to the rear.
- Swinging-arm bearing studs are secured with Loctite: heat to max. 120 °C (248 °F) to release.
- Slacken the floating-bearing stud of the rear wheel drive in the swinging arm.
- Slacken the fixed-bearing stud of the rear wheel drive in the swinging arm.
- Remove floating bearing/fixed bearing stud bolts.
- Remove rear-wheel drive from universal shaft.
- Slacken the floating-bearing stud of the swinging arm in the gearbox.
- Slacken the fixed-bearing stud of the swinging arm in the gearbox.
- Remove floating bearing/fixed bearing stud bolts.
- Remove swinging arm.

- Press off drive shaft.
- Remove the gearbox.

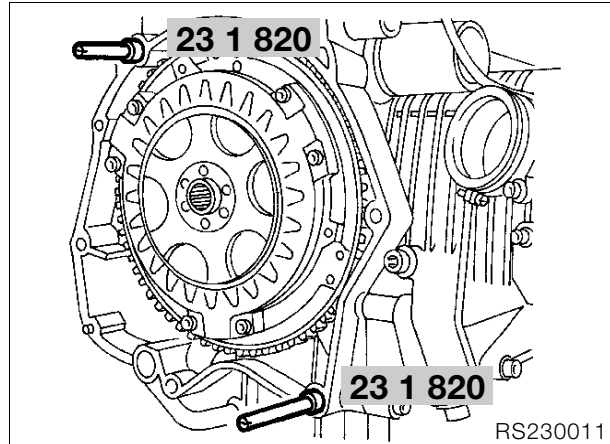

- Always use oiled guide pins, **BMW No. 23 1 820**, when removing or installing the gearbox.

! Caution:

Take care to keep the gearbox at its installed height until the full length of the clutch actuating rod is visible, as otherwise the rod can be bent.

- Installation is the reverse of the removal procedure.

! Caution:

Note correct sequence for tightening fasteners of rear frame to gearbox.

- Switch on the ignition.
- Without starting the engine, fully open the throttle once or twice so that the Motronic control unit can register the throttle-valve positions.

EF Note:

Disconnecting the battery deletes all entries (e.g. faults, settings) stored in the Motronic control unit's memory.

Loss of settings can temporarily impair the operating characteristics when the engine is restarted.

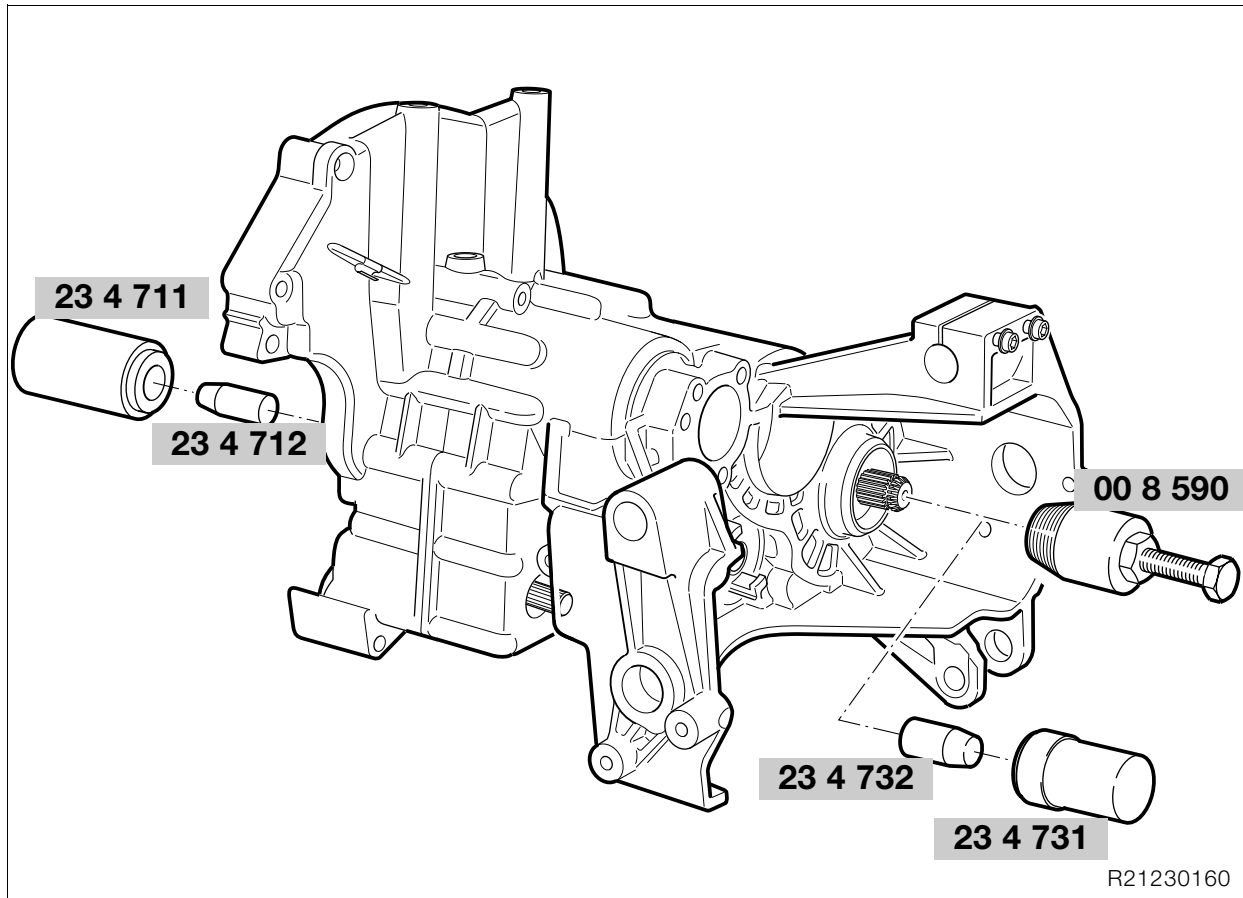

Replacing the shaft sealing rings in the gearbox housing and gearbox cover



Note:

All shaft sealing rings can be replaced with the gearbox installed, apart from the input-side shaft sealing ring on the input shaft.

Replace all shaft sealing rings if the gearbox is fully disassembled.

Lightly oil the sealing lips before installing the shaft sealing rings.



Caution:

Take care not to damage the faces of the casing and the shafts when removing the shaft sealing rings.

Replacing the input shaft sealing ring at input end

- Carefully lever out the shaft sealing ring with a screwdriver.
- Drive the new sealing ring in with the sealing lips facing inwards, using slip-over sleeve, **BMW No. 23 4 712**, and drift, **BMW No. 23 4 711**.

Replacing output shaft sealing ring



Caution:

Do not use pointed tools to remove the shaft sealing ring of the output shaft, because they could damage the sealing washer of the grooved ball bearing behind the sealing ring.

- Use puller, **BMW No. 00 8 590**, to remove the shaft sealing ring, or alternatively pry out carefully with a screwdriver.
- Install the sealing ring with the sealing lip facing inwards, using assembly sleeve, **BMW No. 23 4 732**, and drift, **BMW No. 23 4 731**.



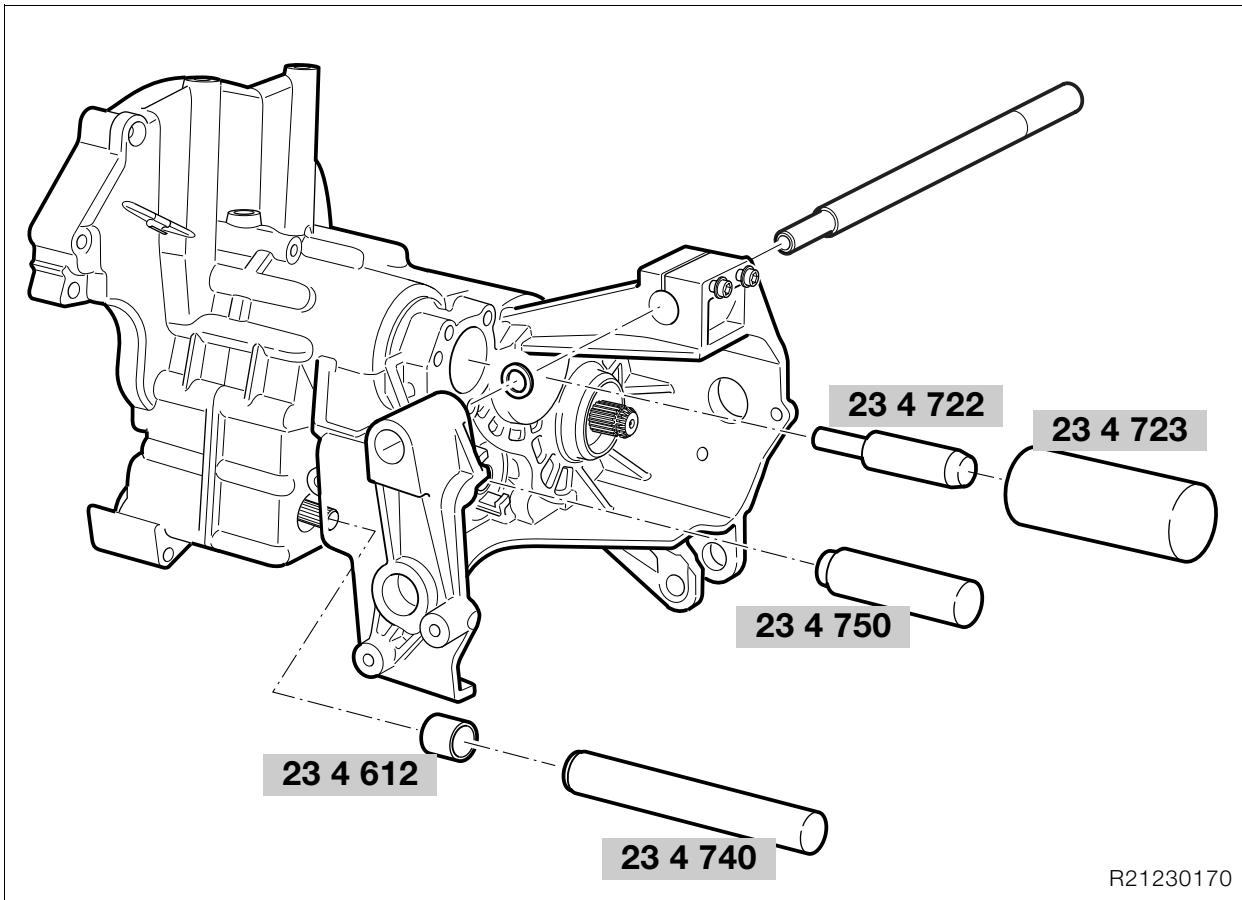

R21230170

Replacing input shaft sealing ring at output end



Caution:

Take care not to damage the faces of the casing and the shafts when removing the shaft sealing rings.



Caution:

Do not use pointed tools to remove the shaft sealing ring of the input shaft, because they could damage the sealing washer of the grooved ball bearing behind the sealing ring.

- Remove the connecting pipe.
- Carefully lever out the shaft sealing ring with a screwdriver.
- Install the new sealing ring with the sealing lips facing inwards, using guide, **BMW No. 23 4 722**, and impact driver, **BMW No. 23 4 723**.

Replacing shaft sealing ring for selector drum

- Carefully lever out the shaft sealing ring with a screwdriver.
- Install the new sealing ring with the sealing lip facing inwards, using impact driver, **BMW No. 23 4 750**.

Replacing sealing ring for selector shaft

- Carefully lever out the shaft sealing ring with a screwdriver.
- Install the new sealing ring with the sealing lip facing inwards, using assembly sleeve, **BMW No. 23 4 612**, and impact driver, **BMW No. 23 4 740**.

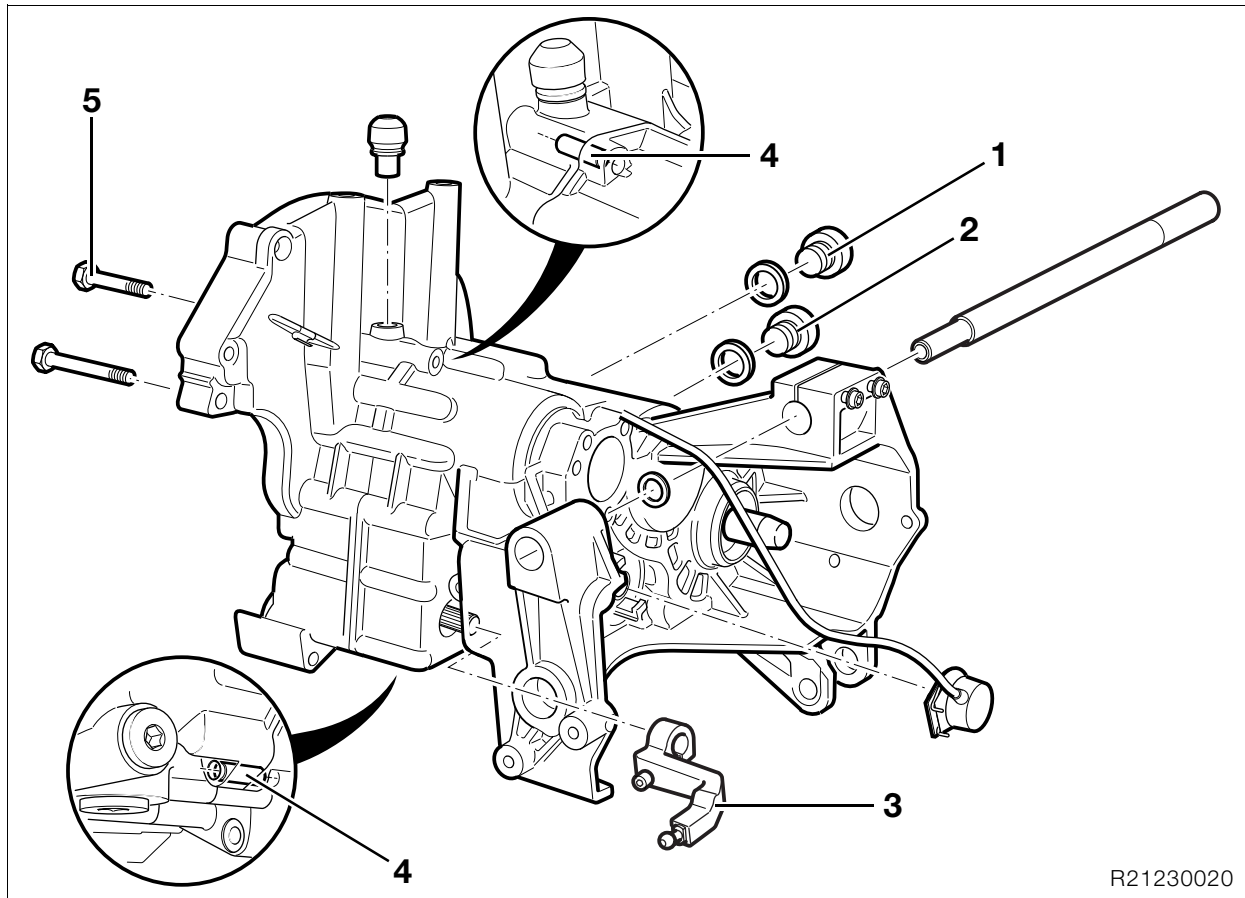

R21230020

Disassembling gearbox

Removing gearbox housing

- Remove oil filler/level check screw (1).
- Remove oil drain plug (2) and drain the oil from the gearbox into a suitable tray.
- Remove selector lever (3).
- Carefully drive back centering pins (4), from the cover side or casing side, as applicable.
- Remove screws (5) securing cover to housing.

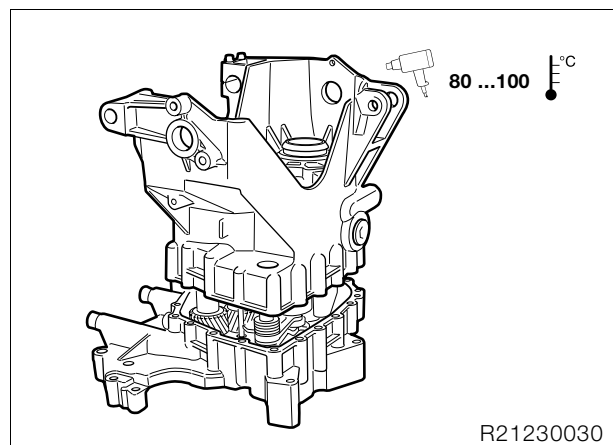

R21230030

- Set the gearbox down on its cover.



Caution:

Avoid damage to the housing cover and painted surfaces.

- Heat the bearing points in the housing to 80 °C ... 100 °C (176 °F ... 212 °F).
- Tap lightly with a plastic-faced hammer to disengage the housing.

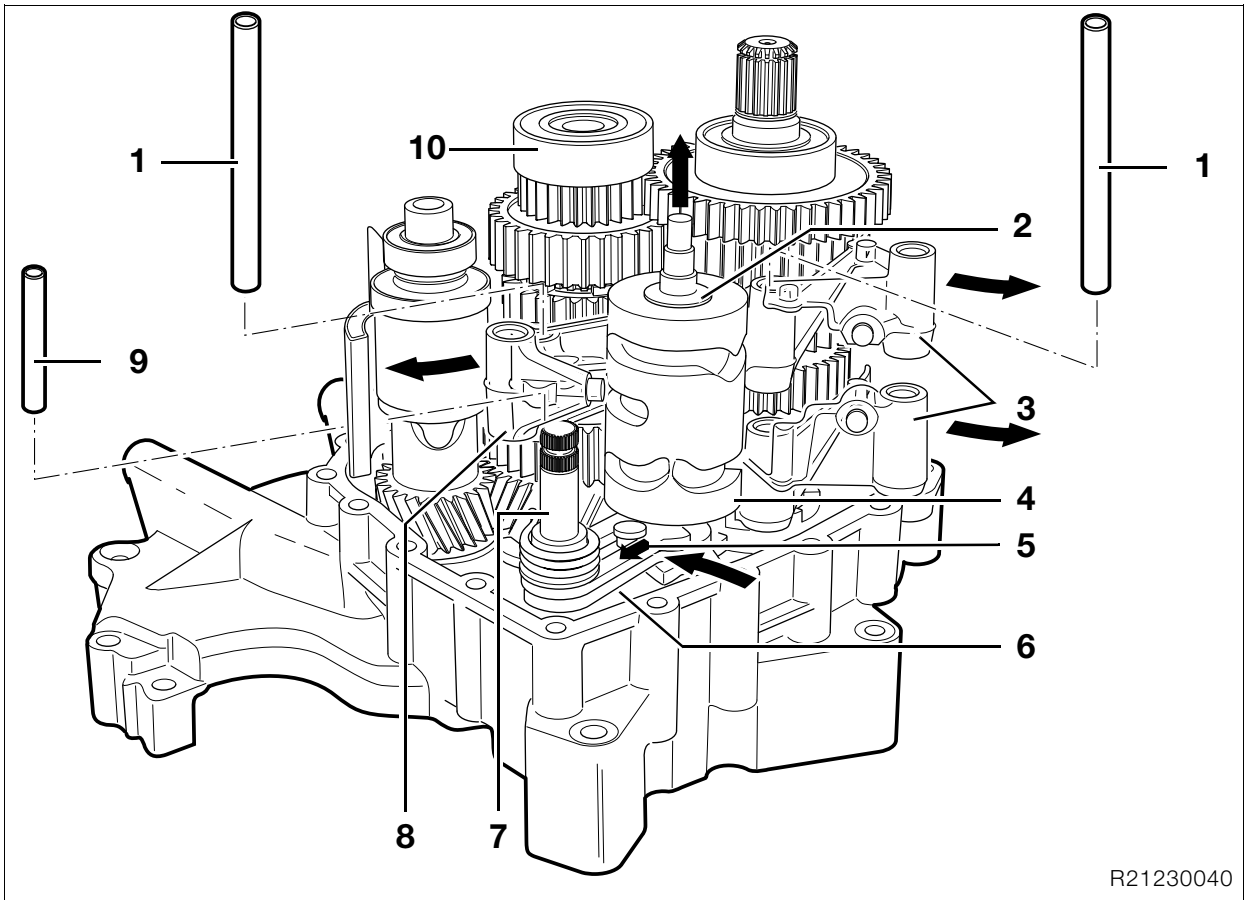

R21230040

Removing selector drum

- Pull the selector shafts (1) out of the selector forks.
- Swing the selector forks (3/8) out towards the edge of the cover (arrows).
- Remove locking pin (9).
- Press guide plate (5) in the opposite direction to the spring loading (arrow).
- Swing locking lever (6) towards input shaft, hold it there and pull out the selector drum (4), turning it slightly at the same time.

Disassembling/assembling selector shaft

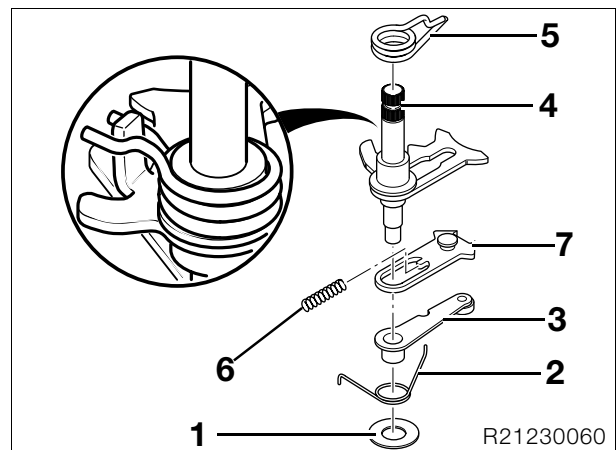

R21230060

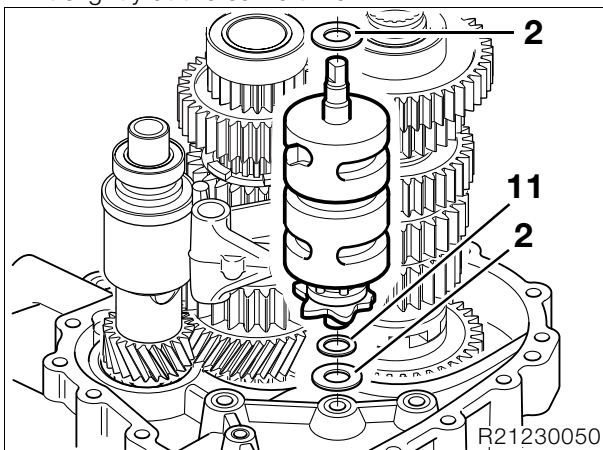

R21230050

- Remove thrust washers (2) and spacing washer (11).
- Release the locking lever (6).
- Remove the selector shaft (7) with spacing washer.
- Remove selector forks (3).
- Selector fork (8) remains in the intermediate shaft (10).

- Take off spacing washer (1).
- Remove torsion spring (2) with locking lever (3) from selector shaft (4).
- Remove torsion spring (5).
- Disengage coil spring (6) and remove together with guide plate (7).
- Assembly is the reverse of the disassembly procedure.

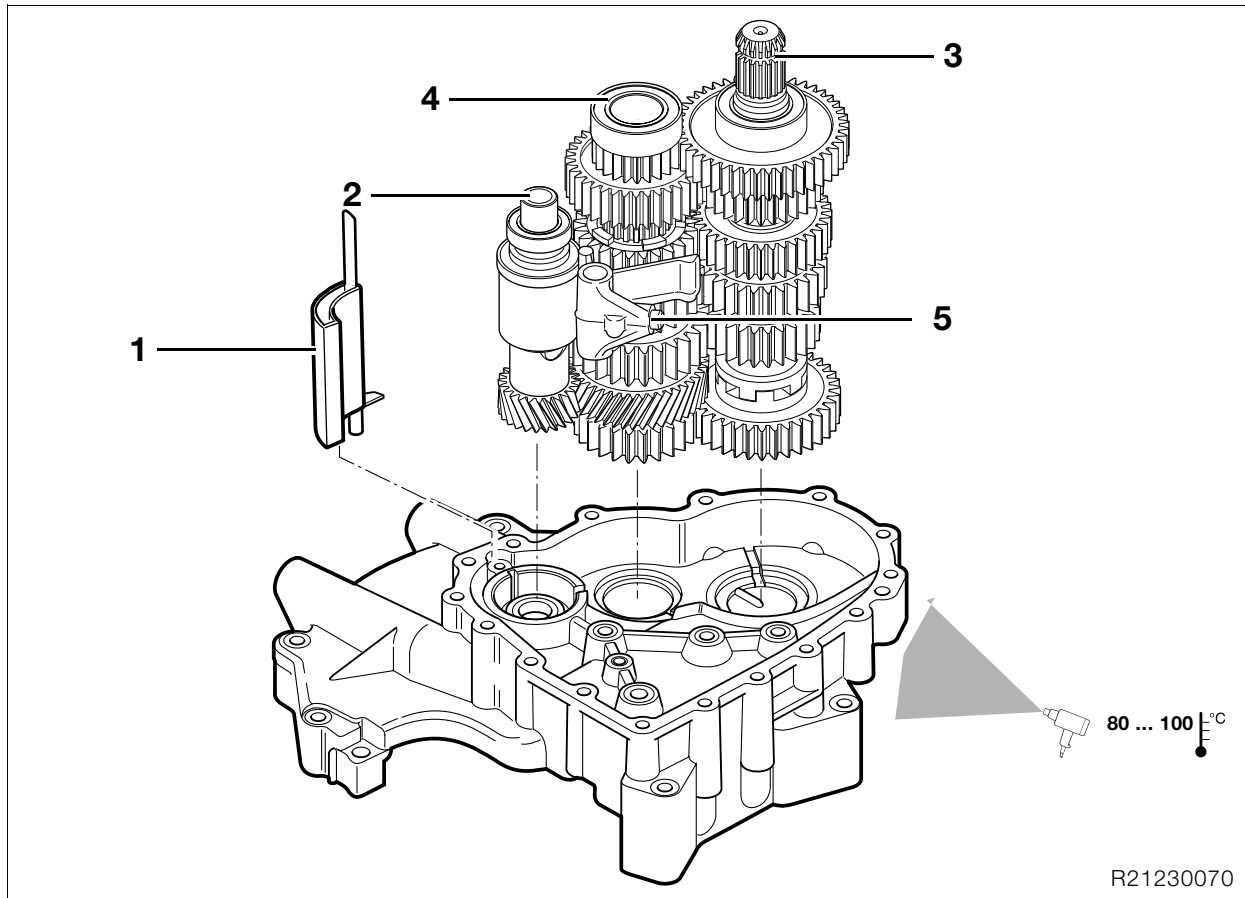

R21230070

Removing gearbox shafts

- Remove breather tube (1).
- Heat bearing points in gearbox cover to 80 °C ... 100 °C (176 °F ... 212 °F).
- Remove input shaft (2), output shaft (3) and intermediate shaft (4) together from the cover.
- Remove selector fork (5) from intermediate shaft.
- Mark the selector fork with a felt-tipped pen or similar.

Replacing grooved ball bearings of intermediate shaft

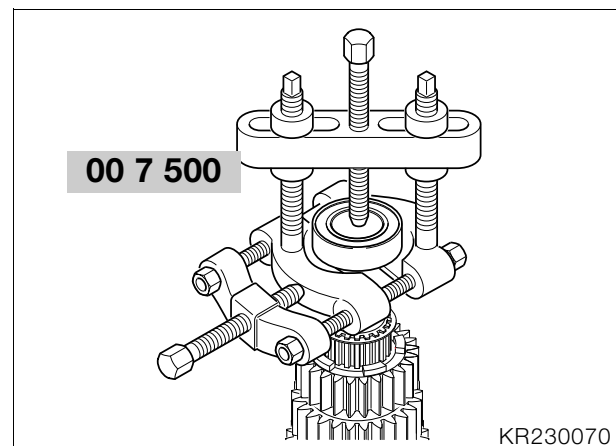

KR230070

Caution:

If the grooved ball bearings are replaced, the fully assembled length must be re-adjusted.

- Pull off the grooved ball bearings with a universal puller, **BMW No. 00 7 500**.
- Press the output-side grooved ball bearing on to the intermediate shaft.
- Check/adjust fully-assembled length (→ 23.19).
- Place spacing washer of calculated thickness in position and press on the input-side grooved ball bearing.

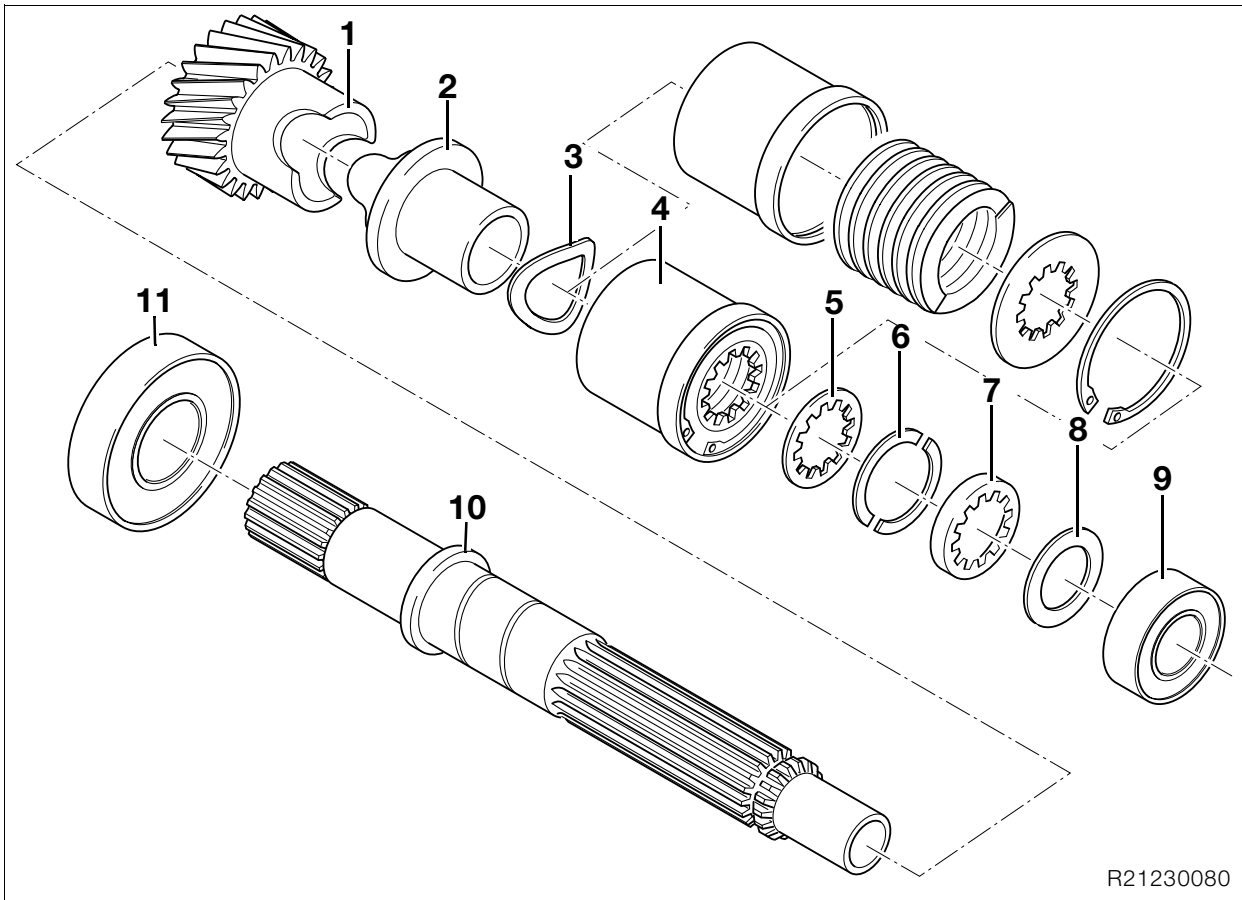

R21230080

Disassembling/assembling input shaft

Disassembling input shaft

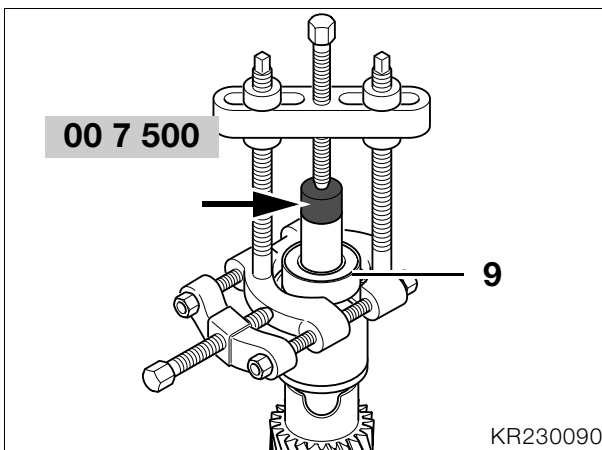

KR230090

- Remove retaining ring (7).
- Compress spring cluster (4) and remove keepers (6).
- Remove spacer (5), spring cluster (4), anti-rattle disc (3), thrust block (2) and constant-speed gear (1).
- Clamp input shaft (10) other way round in vise.
- Use universal puller, **BMW No. 00 7 500**, and pressure head (arrow) to pull off grooved ball bearing (11).

- Clamp the input shaft into a vise with soft jaws.
- Use universal puller, **BMW No. 00 7 500**, and pressure head (arrow) to pull off grooved ball bearing (9) with spacing washer (8).
- Note the thickness of spacing washer (8).

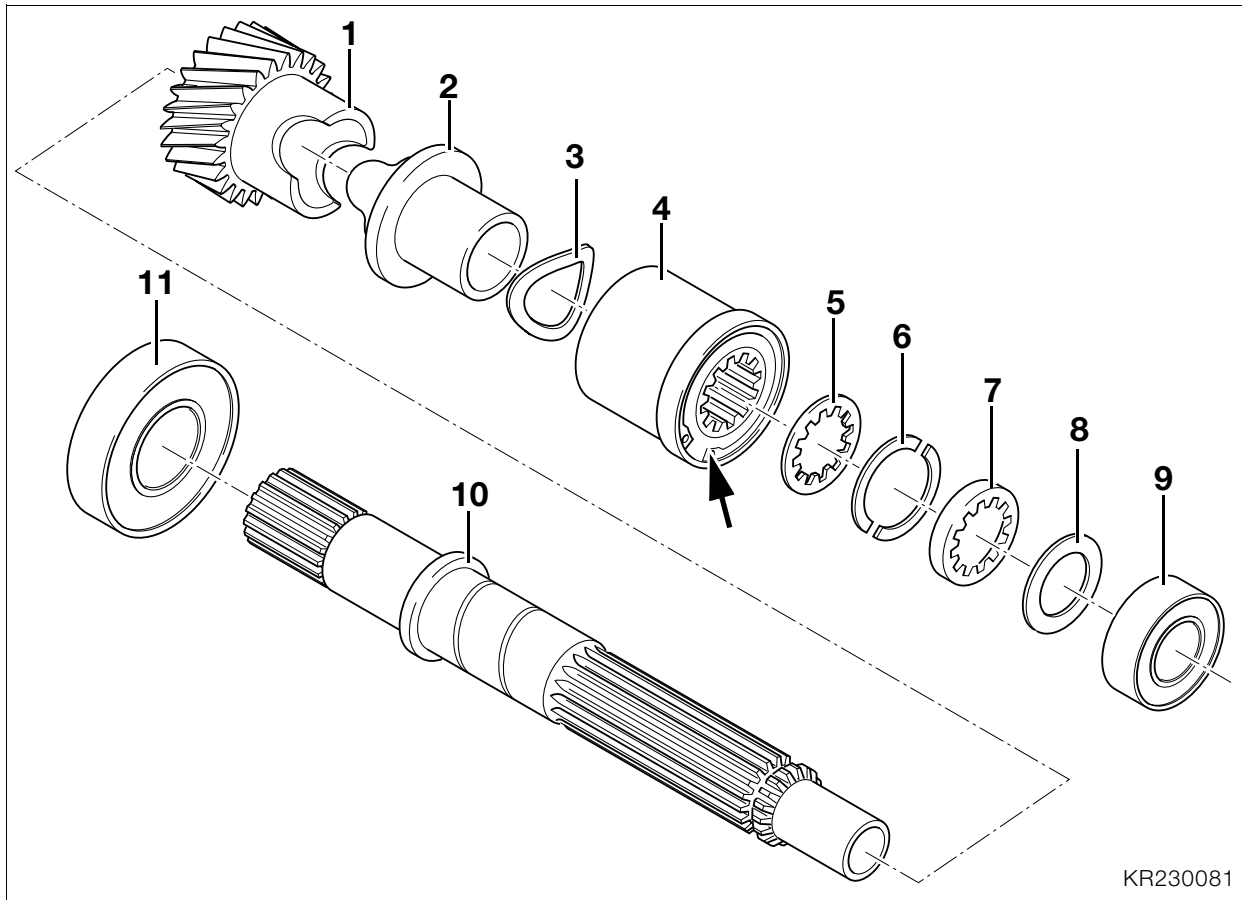

KR230081

Assembling input shaft/checking and adjusting axial play of spring cluster

- Lightly oil the bearing surface for constant-speed gear (1) on input shaft (10), and install the constant-speed gear.
- Lightly oil the splines in thrust block (2) and install it.
- Place anti-rattle disc (3) on thrust block (2).
- Mount spring cluster (4) with locating ring (arrow) facing upwards on anti-rattle disc (3).
- Install spacer (5).
- Compress spring cluster (4) and insert the keepers (6) in the ring groove.
- Install retaining ring (7) with the shoulder facing over keepers (6).

- Install spacing washer (8) of calculated thickness, and press on grooved ball bearing (9).

Endplay:

Spring cluster on shaft
 0.4...0.6 mm (0.0157 ... 0.0236 in)

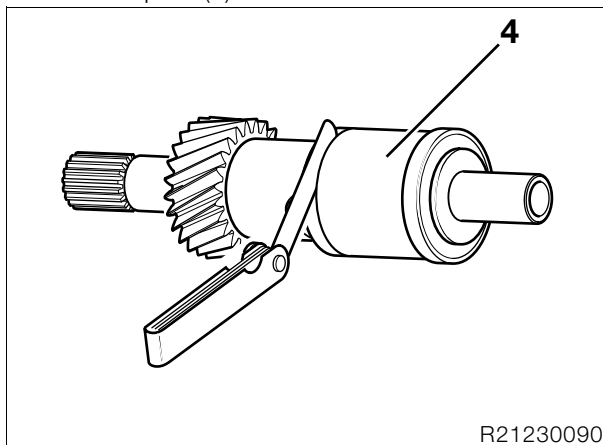

R21230090

- Check axial play of spring cluster (4); correct if necessary by installing spacer (5) of suitable thickness.
- Check fully assembled length and adjust if necessary (→ 23.21).

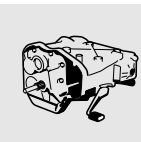

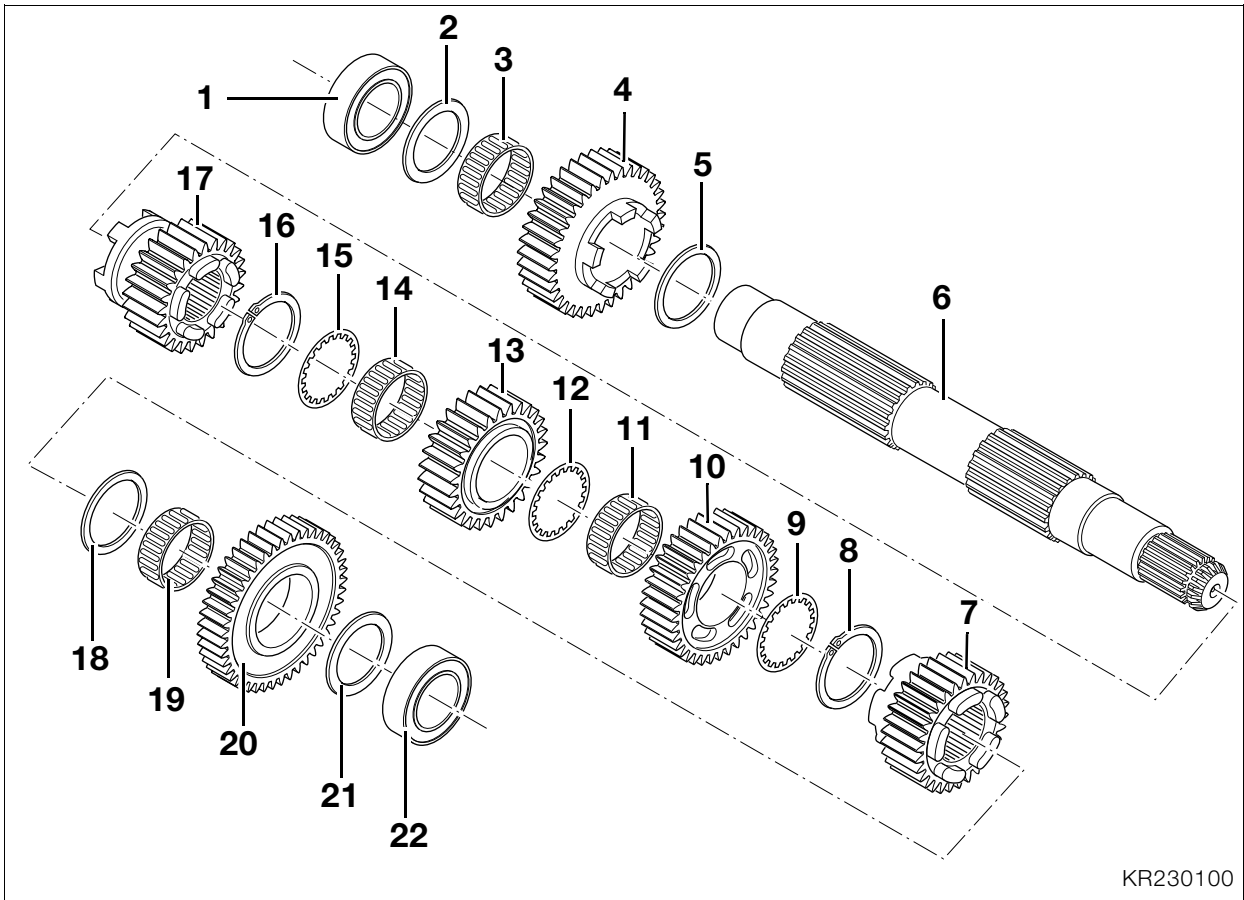

KR230100

Disassembling/reassembling output shaft

Disassembling output shaft



Caution:

To avoid damaging the needle roller bearing on the splines of the shaft, spread it carefully at the end face when removing.

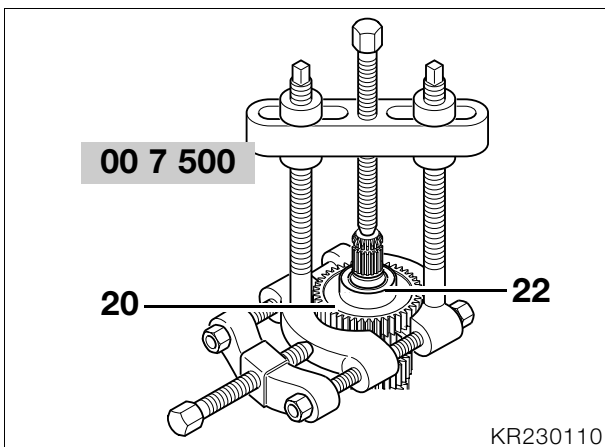
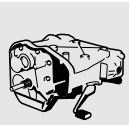

KR230110

- Using universal puller, **BMW No. 00 7 500**, pull off grooved ball bearing (22) together with 1st gearwheel (20).

- Remove spacing washer (21), shift gearwheel for 1st gear (20), needle roller bearing (19) and spacing washer (18).
- Remove sliding gearwheel (7).
- Remove circlip (8), backup washer (9), shift gearwheel for 3rd gear (10) and needle roller bearing (11).
- Remove backup washer (12), 4th gear shift wheel (13), needle roller bearing (14) and backup washer (15).
- Remove circlip (16) and sliding gearwheel for 5th gear (17).
- Turn output shaft (6) other way round and clamp into the vise with soft jaws.
- Using universal puller, **BMW No. 00 7 500**, pull off deep-groove ball bearing (1) together with shift gearwheel for 2nd gear (4).
- Remove shim washer (2), needle roller bearing (3), shift gearwheel for 2nd gear (4) and thrust washer (5).

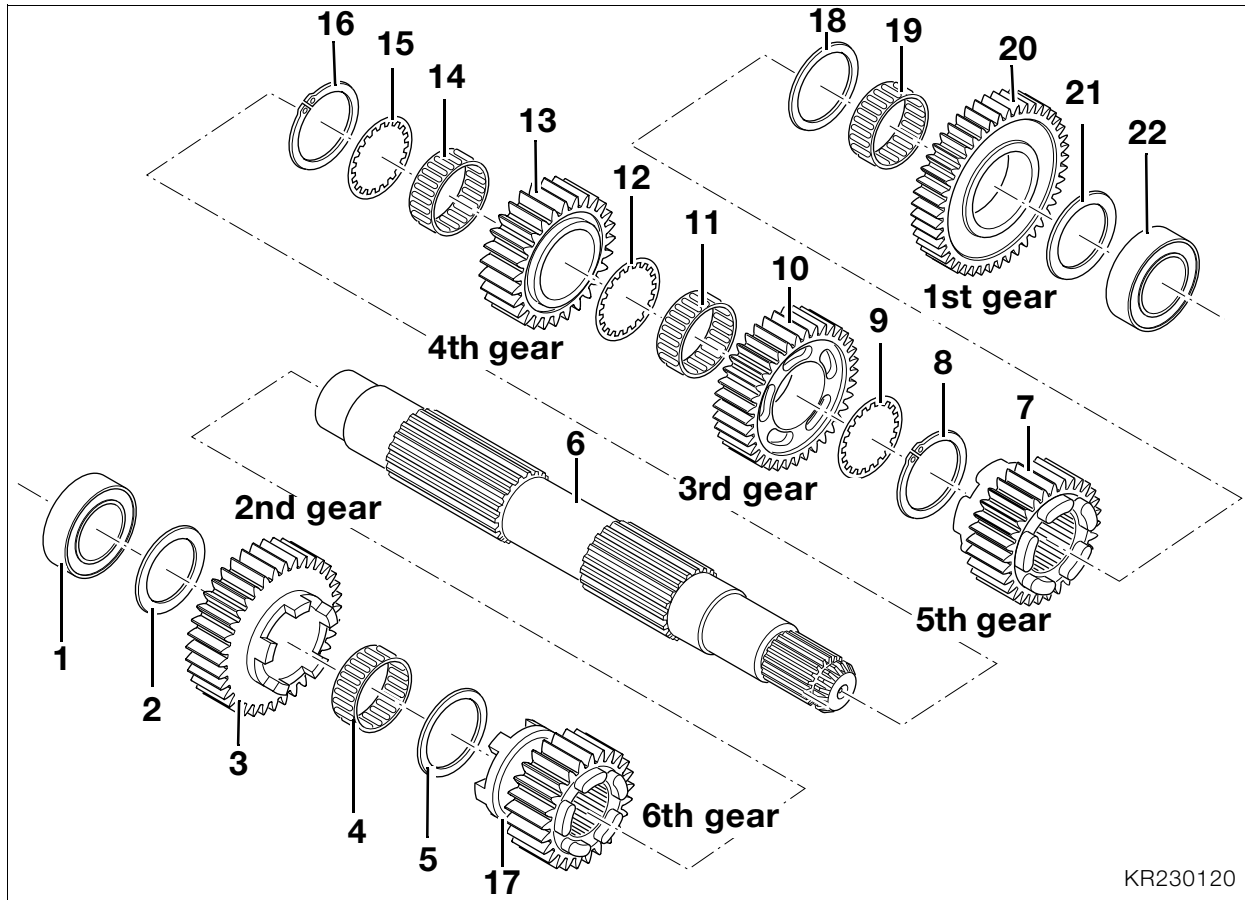

KR230120

Assembling output shaft



Note:

Assembly starts at the shift gearwheel for 4th gear. Before assembly, lightly coat all friction faces with gear oil.

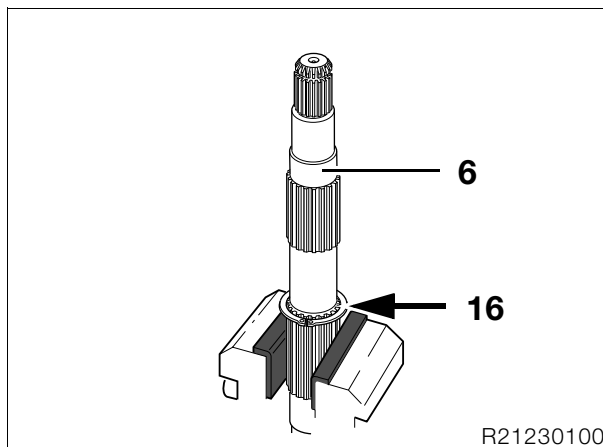

R21230100

- Clamp output shaft (6) into a vise fitted with jaw protectors, with the splines facing upwards.
- Install circlip (16/arrow).
- Install backup washer (15).

- Install needle roller bearing (14).



Caution:

To avoid damaging the needle roller bearing on the splines of the shaft, spread it carefully at the end face when installing.

- Install shift wheel for 4th gear (13) with the pockets facing circlip (16).
- Install backup washer (12) and needle roller (11).
- Install shift wheel for 3rd gear (10) with pockets facing away from the 4th gear shift wheel (13).
- Install backup washer (9) and circlip (8).
- After installing the 3rd and 4th shift wheels, measure endplay (→ 23.18).
- Install shift wheel for 5th gear (7) with recess for shift fork facing towards the 3rd gear shift wheel (10).
- Install backup washer (18) and needle roller bearing (19).
- Install the shift gearwheel for 1st gear (20) with the pockets facing sliding gearwheel (7).
- Install spacing washer (21) and grooved ball bearing (22).
- After installing, check endplay at the shift gearwheel for 1st gear (→ 23.18).

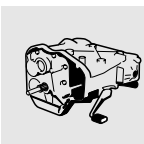

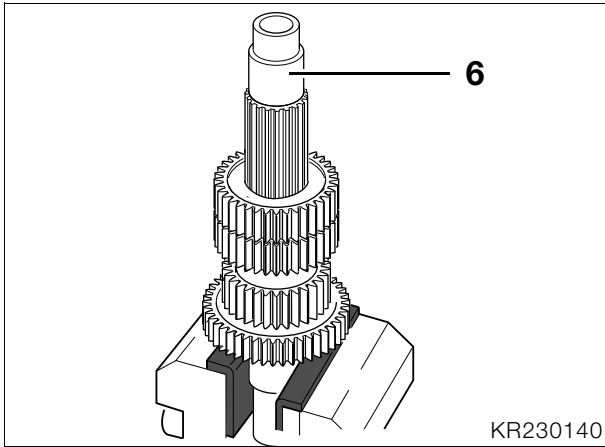

- Reverse position of output shaft (6) in vise.
- Install sliding gearwheel for 6th gear (17) with the recess for the selector fork facing the 2nd gear shift wheel (3).
- Install backup washer (5) and needle roller bearing (4).
- Install the shift wheel for 2nd gear (3) with the dogs facing the 6th gear sliding gearwheel (17).
- Check/adjust fully-assembled length (→ 23.20).
- Install spacing washer (2) of calculated thickness, and press on grooved ball bearing (1).
- Check 2nd gear endplay.

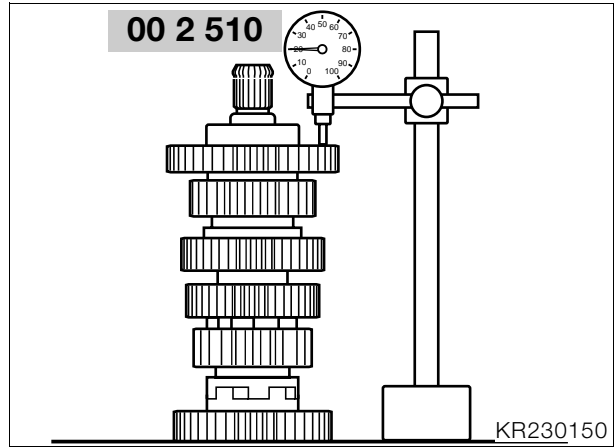

Checking endplay

- Secure dial gauge, **BMW No. 00 2 510**, to dial gauge stand.
- Position dial-gauge stylus on edge of the gear-wheel and check endplay.



Caution:

Excessive endplay is due to incorrect assembly or worn needle roller bearings, backup washers or spacing washers, or the shift gear. Check and replace as necessary.
Check for wear and replace the affected parts.

Endplay values:

Endplay, 1st gear	0.1...0.33 mm (0.004 ... 0.013 in)
Endplay, 2nd gear	0.1...0.33 mm (0.004 ... 0.013 in)
Endplay, 3rd/4th gear (total play).....	0.1...0.67 mm (0.004 ... 0.026 in)

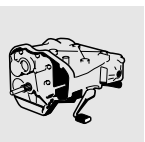

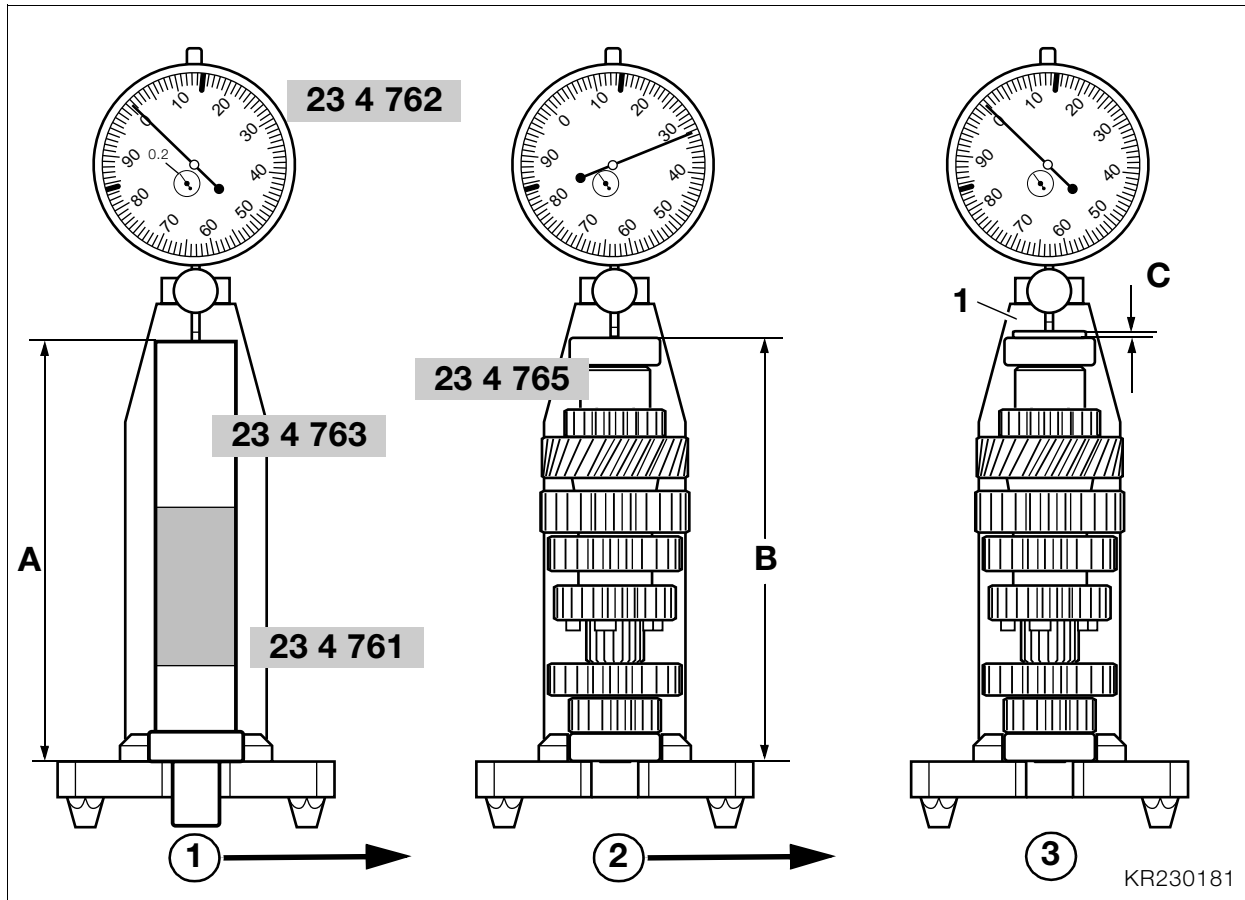

Checking/adjusting fully assembled length of gearbox shafts and selector drum

Checking/adjusting fully-assembled length of intermediate shaft



Caution:

Check and adjust the fully assembled length as described below and install a spacing washer of the correct thickness.

Before measuring, always make sure that the grooved ball bearings are pressed fully home, even if the shaft has not been disassembled and reassembled.

- Position dial gauge, **BMW No. 23 4 762**, in rear locating bore of stand, **BMW No. 23 4 761**, and set to 0.2 mm (0.008 in) preload.
- Using dial gauge, zero to dimension "A" of the zero gauge, **BMW No. 23 4 763**.
- Pull off the input-side grooved ball bearing with universal puller, **BMW No. 00 7 500**.
- Remove the spacing washer.
- Place reference washer, **BMW No. 23 4 765**, on the intermediate shaft.
- Place the grooved ball bearing on the reference washer.
- Insert intermediate shaft in measuring stand.

- Using the dial gauge, measure the deviation from zero of dimension "B" at the inner bearing race. Deviation from zero is equivalent to the thickness "C" of spacer (1).
- Place a spacer (1) of the correct thickness on the bearing inner ring and check deviation from zero.

$$A = B + C$$



Caution:

The maximum deviation from zero must not be exceeded.

- Remove the intermediate shaft from the measuring fixture.
- Take off spacing washer, grooved ball bearing and reference washer.
- Place a spacing washer (1) of the correct thickness on the intermediate shaft and press on the grooved ball bearing.

Reference dimension for intermediate shaft:

Maximum deviation from zero
 -0.05...0 mm (-0.002...0.00 in)

KR230181

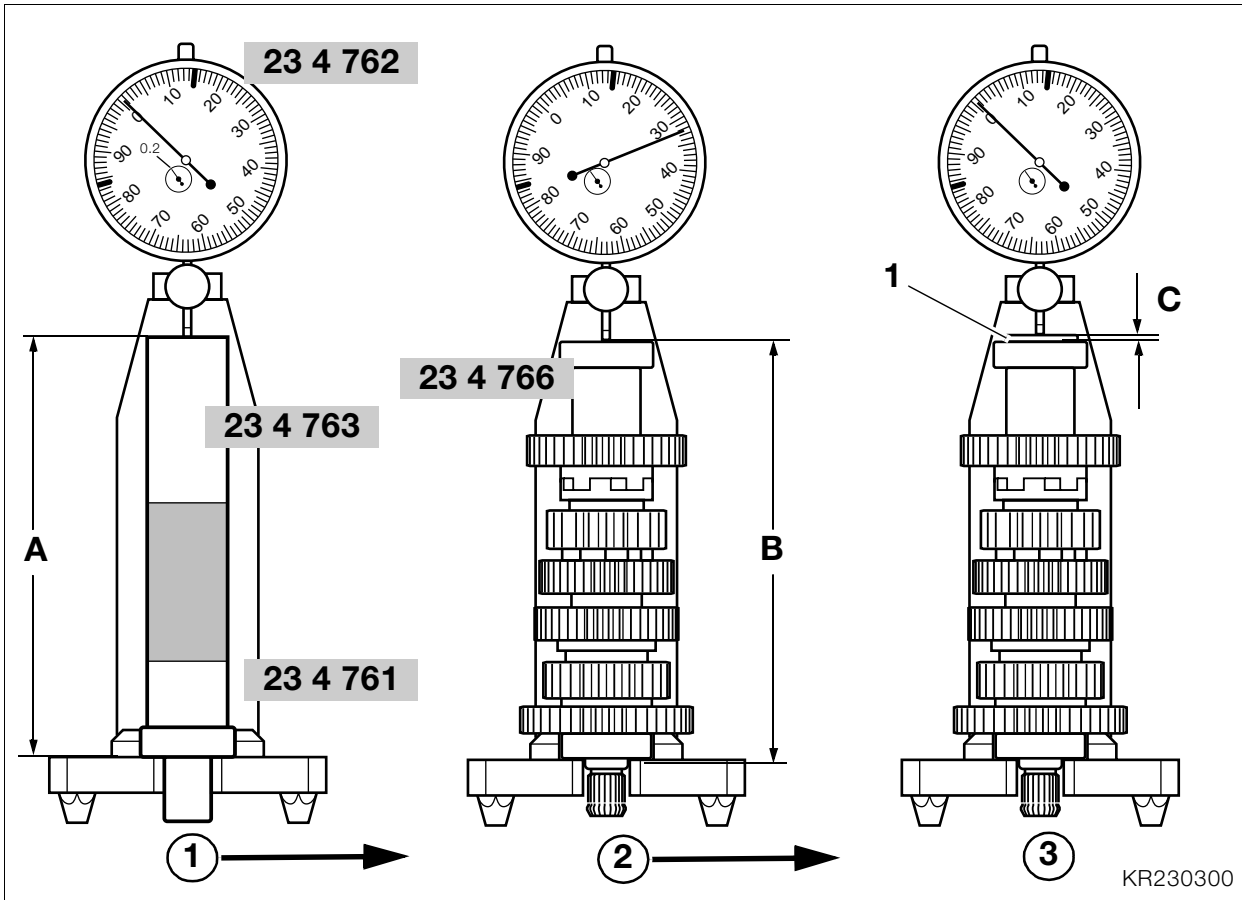

Checking/adjusting fully-assembled length of output shaft

Caution:

Check and adjust the fully assembled length as described below and install a spacing washer of the correct thickness.

Before measuring, always make sure that the grooved ball bearings are pressed fully home, even if the shaft has not been disassembled and reassembled.

- Position dial gauge, **BMW No. 23 4 762**, in rear locating bore of stand, **BMW No. 23 4 761**, and set to 0.2 mm (0.008 in) preload.
- Using dial gauge, zero to dimension "A" of the zero gauge, **BMW No. 23 4 763**.
- Pull off the input-side grooved ball bearing with universal puller, **BMW No. 00 7 500**.
- Remove the spacing washer.
- Place reference washer, **BMW No. 23 4 766**, on the output shaft.
- Place the grooved ball bearing on the reference washer.
- Insert the output shaft into the measuring stand.

- Using the dial gauge, measure the deviation from zero of dimension "B" at the inner bearing race. Deviation from zero is equivalent to the thickness "C" of spacer (1).
- Place a spacer (1) of the correct thickness on the bearing inner ring and check deviation from zero.

A = B + C

Caution:

The maximum deviation from zero must not be exceeded.

- Take off spacing washer, grooved ball bearing and reference washer.
- Place a spacing washer (1) of the correct thickness on the output shaft and press on the grooved ball bearing.

Reference dimension for input shaft:

Maximum deviation from zero
 -0.05...0 mm (-0.002...0.00 in)

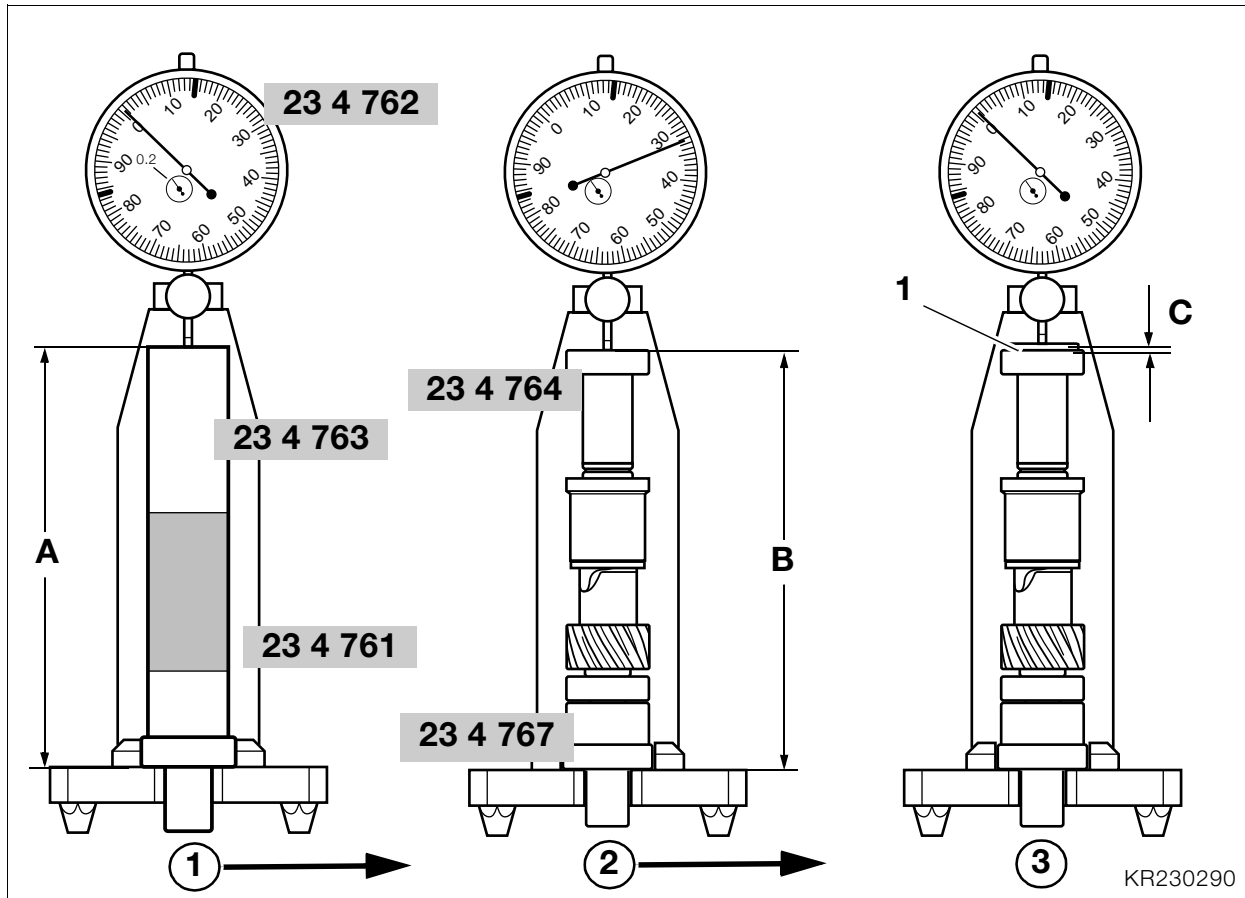

Checking/adjusting fully-assembled length of input shaft

Caution:

Check and adjust the fully assembled length as described below and install a spacing washer of the correct thickness.

Before measuring, always make sure that the grooved ball bearings are pressed fully home, even if the shaft has not been disassembled and reassembled.

- Position dial gauge, **BMW No. 23 4 762**, in front locating bore of stand, **BMW No. 23 4 761**, and set to 0.2 mm (0.008 in) preload.
- Using dial gauge, zero to dimension "A" of the zero gauge, **BMW No. 23 4 763**.
- Pull off the output-side grooved ball bearing with universal puller, **BMW No. 00 7 500**.
- Remove the spacing washer.
- Mount reference washer, **BMW No. 23 4 764**, on the input shaft.
- Place the grooved ball bearing on the reference washer.
- Insert input shaft with adapter disc, **BMW No. 23 4 767**, in measuring stand.

- Using the dial gauge, measure deviation from zero of dimension "B" at the inner bearing race. Deviation from zero is equivalent to the thickness "C" of spacer (1).
- Place a spacer (1) of the correct thickness on the bearing inner ring and check deviation from zero.

A = B + C

Caution:

The maximum deviation from zero must not be exceeded.

- Take the input shaft out of the measuring fixture.
- Remove the adapter disc, spacing washer, grooved ball bearing and reference washer.
- Place a spacing washer (1) of the correct thickness in position and press the grooved ball bearing on to the input shaft.

Reference dimension for drive shaft:

Maximum deviation from zero
 -0.05...0 mm (-0.002...0.00 in)

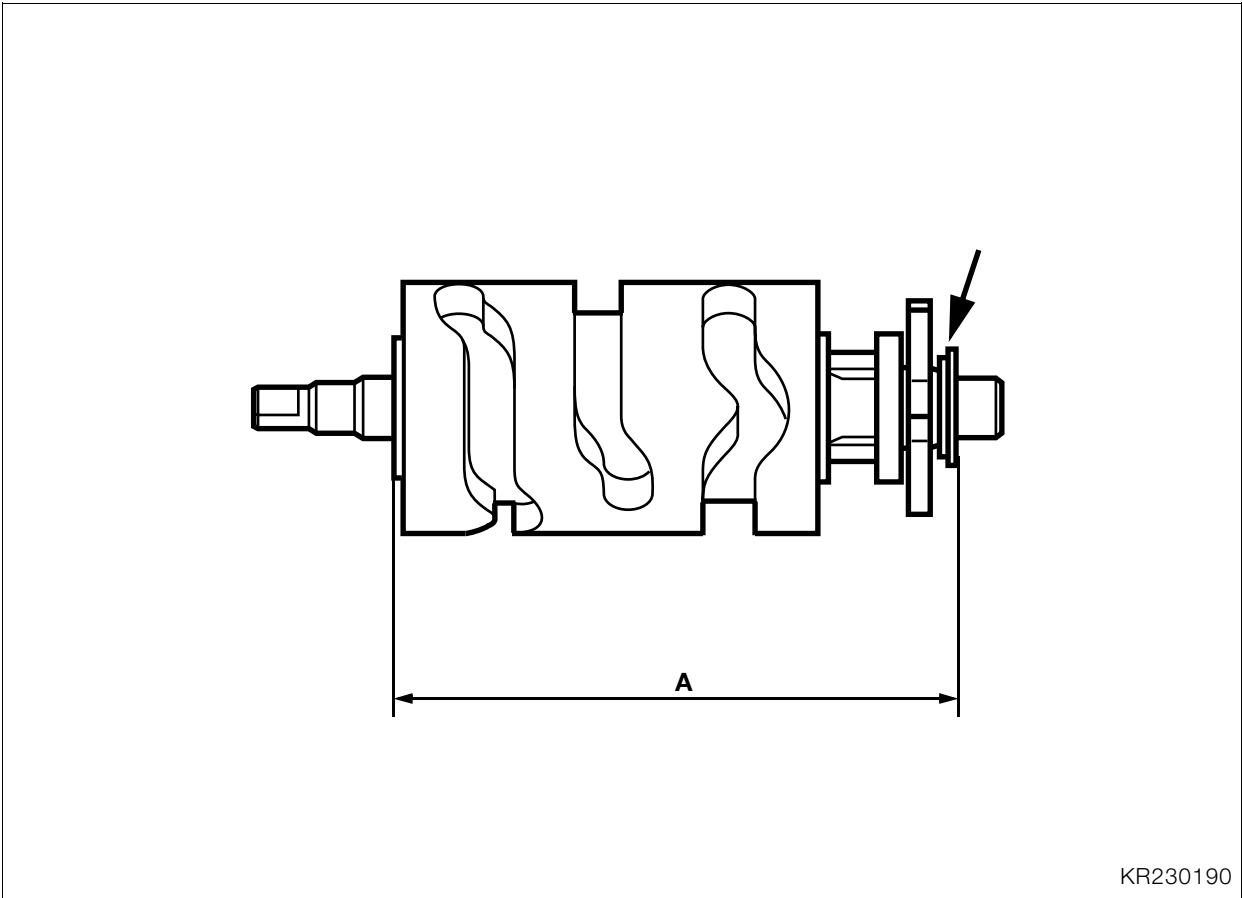

KR230190

Checking/adjusting fully assembled length of selector drum

- Place spacing washer and both thrust washers on the selector drum.
- Using slide gauge, determine fully assembled length "A".
- If necessary, adjust fully assembled length "A" with a shim washer (arrow).

Fully assembled length:

Selector drum
 111.80...111.90 mm (4.402 ... 4.406 in)

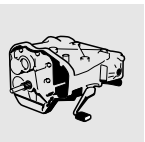

Shimming selector shaft



Caution:

If the housing or the complete selector shaft is replaced, the selector shaft must be measured and shimmed.

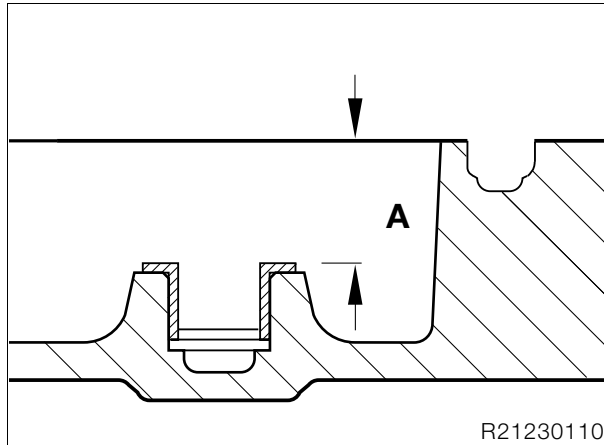

- Measure distance "A" from shouldered bushing to cover mating face.

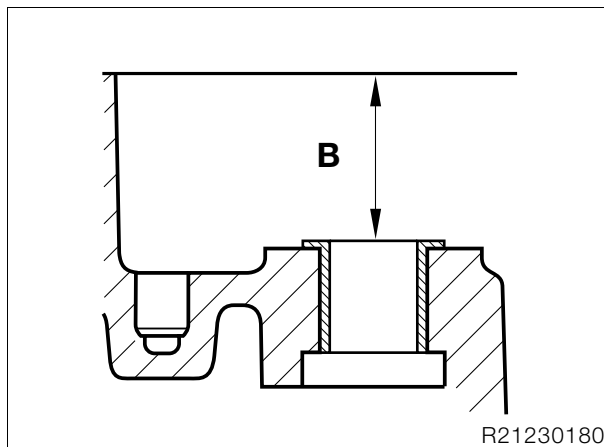

- Measure distance "B" from shouldered bushing to housing mating face.

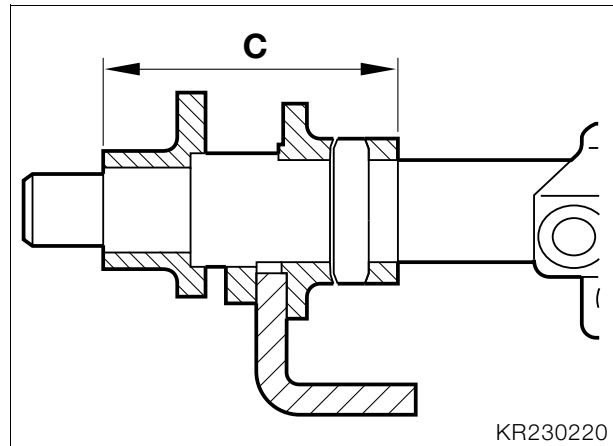

- Measure distance "C" from the shoulder on the selector shaft to the back of the sleeve.
- Calculate endplay as follows:

$$A + B = D$$

$$D - C = E$$

E - thickness of spacer = endplay.

Endplay:

Selector shaft 0.1...0.3 mm (0.004 ... 0.012 in)

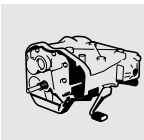

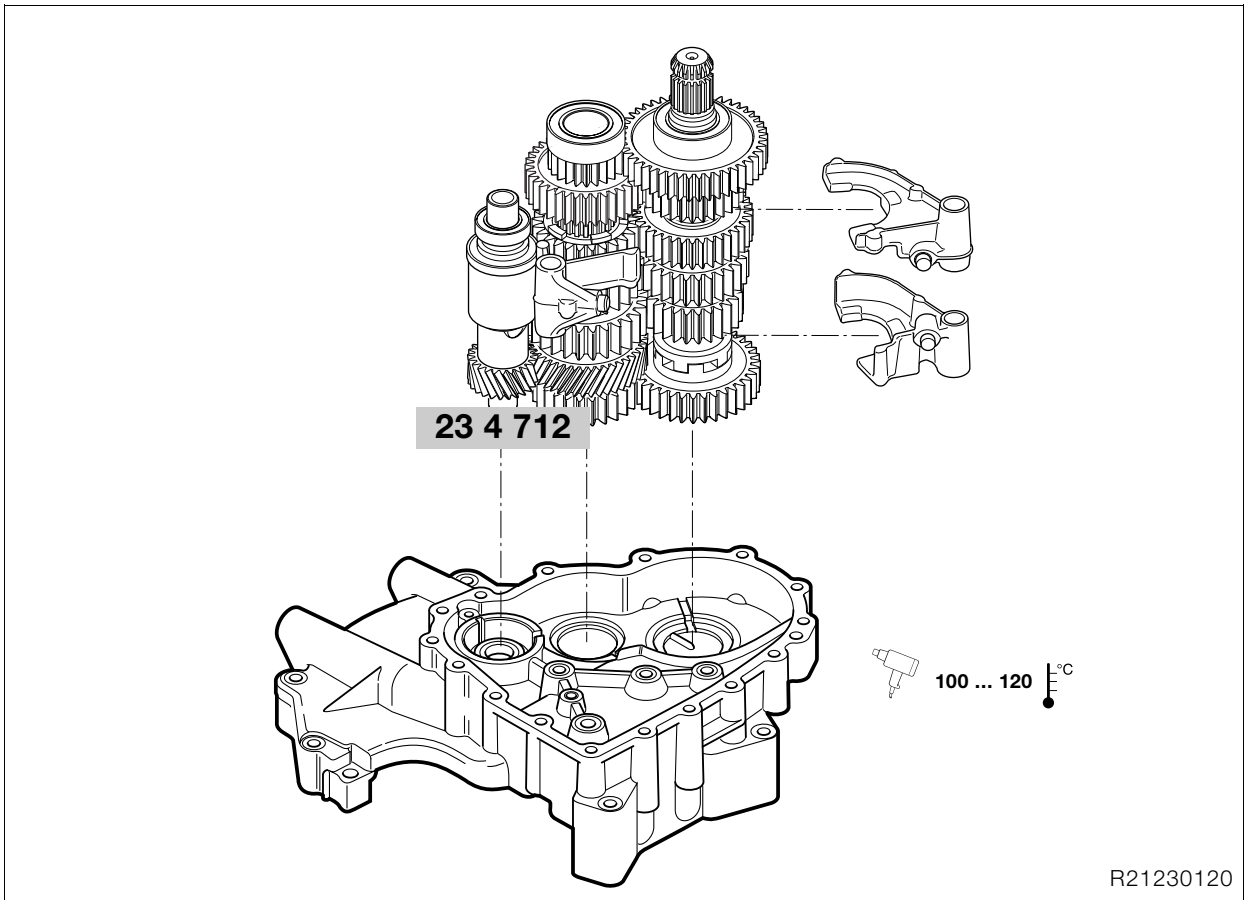

Assembling gearbox

Installing input, output and intermediate shafts

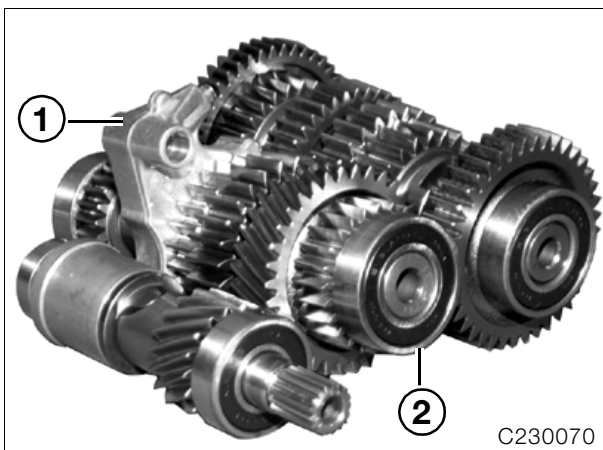

- Insert marked selector fork (1) into intermediate shaft (2).

- Align input, output and intermediate shafts so that their gear teeth mesh and the selector fork is in the position illustrated.
- Push assembly sleeve, **BMW No. 23 4 712**, on to the input shaft splines.



Note:

This is necessary only if the shaft sealing ring is installed.

- Heat the bearing points in the cover to 100 ... 120 °C (176 °F ... 212 °F).
- Insert the input, output and intermediate shafts together.



Caution:

Check that the gearbox shafts are correctly seated.

- Install the 1st/3rd and 2nd/4th shift forks.

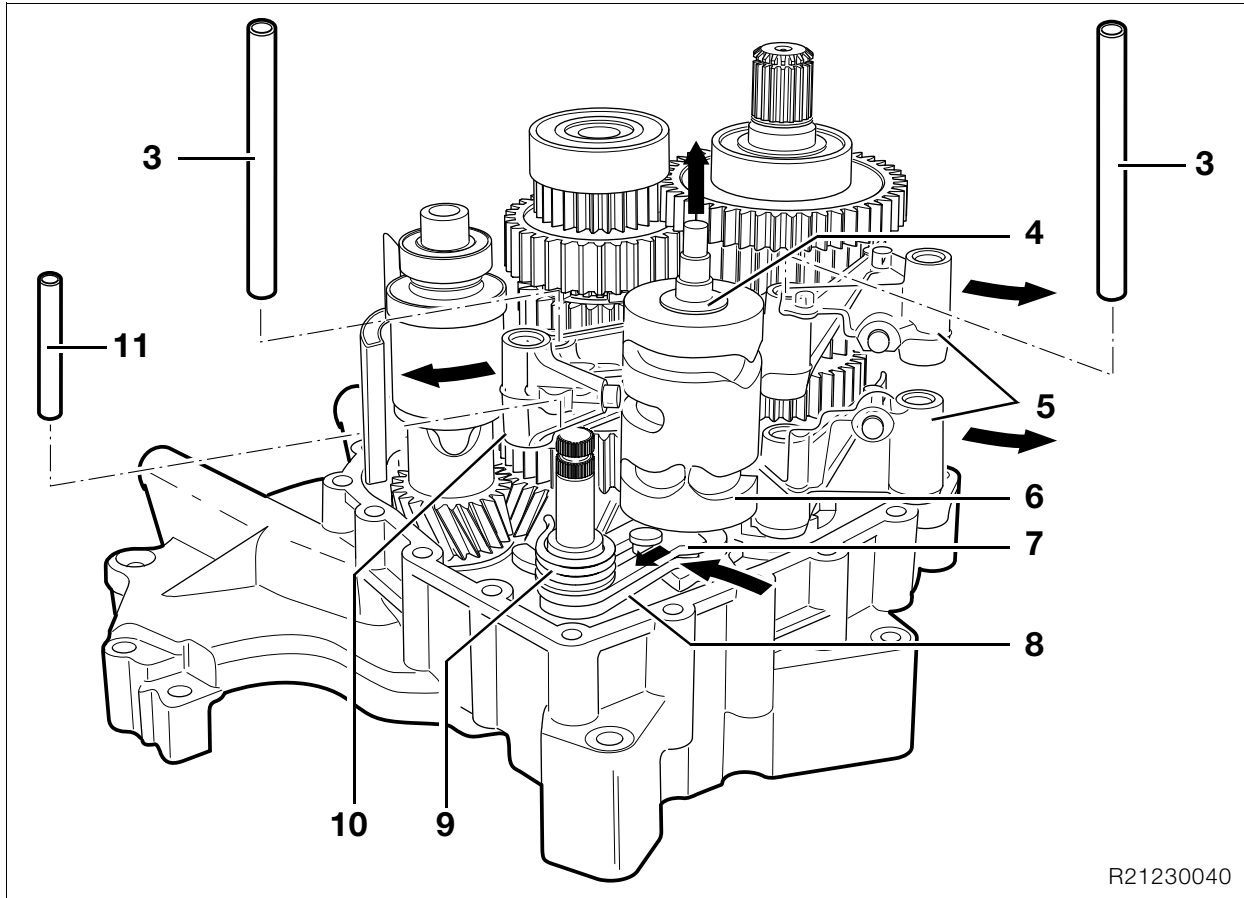

R21230040

Installing selector shaft

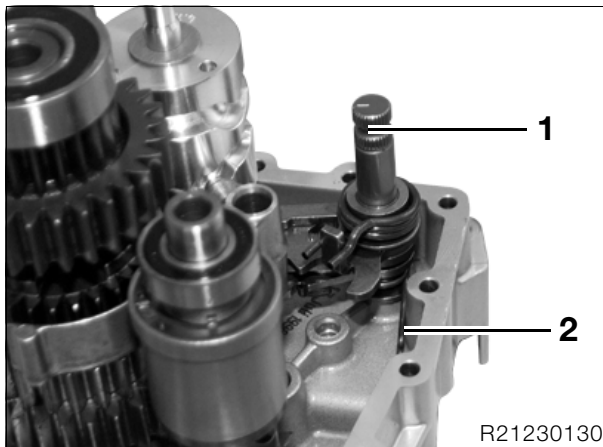

R21230130

- Place a spacer of correct thickness on the housing.
- Install selector shaft (1), making sure that spring (2) is correctly positioned.

Installing selector drum

- Place a spacing washer of the correct thickness and the input-side thrust washer on selector drum (6) and secure with a small amount of grease.
- Swing locking lever (8) toward the input shaft and install the selector drum.
- Swing locking lever (8) towards selector drum (6), pull back guide plate (7) and engage it in the selector drum.
- Place shift forks (5, 10) in the guide tracks.
- Install selector shafts (3).
- Install torsion spring (9).
- Install locking pin (11).
- Place thrust washer (4) on the selector drum.

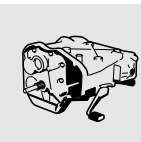

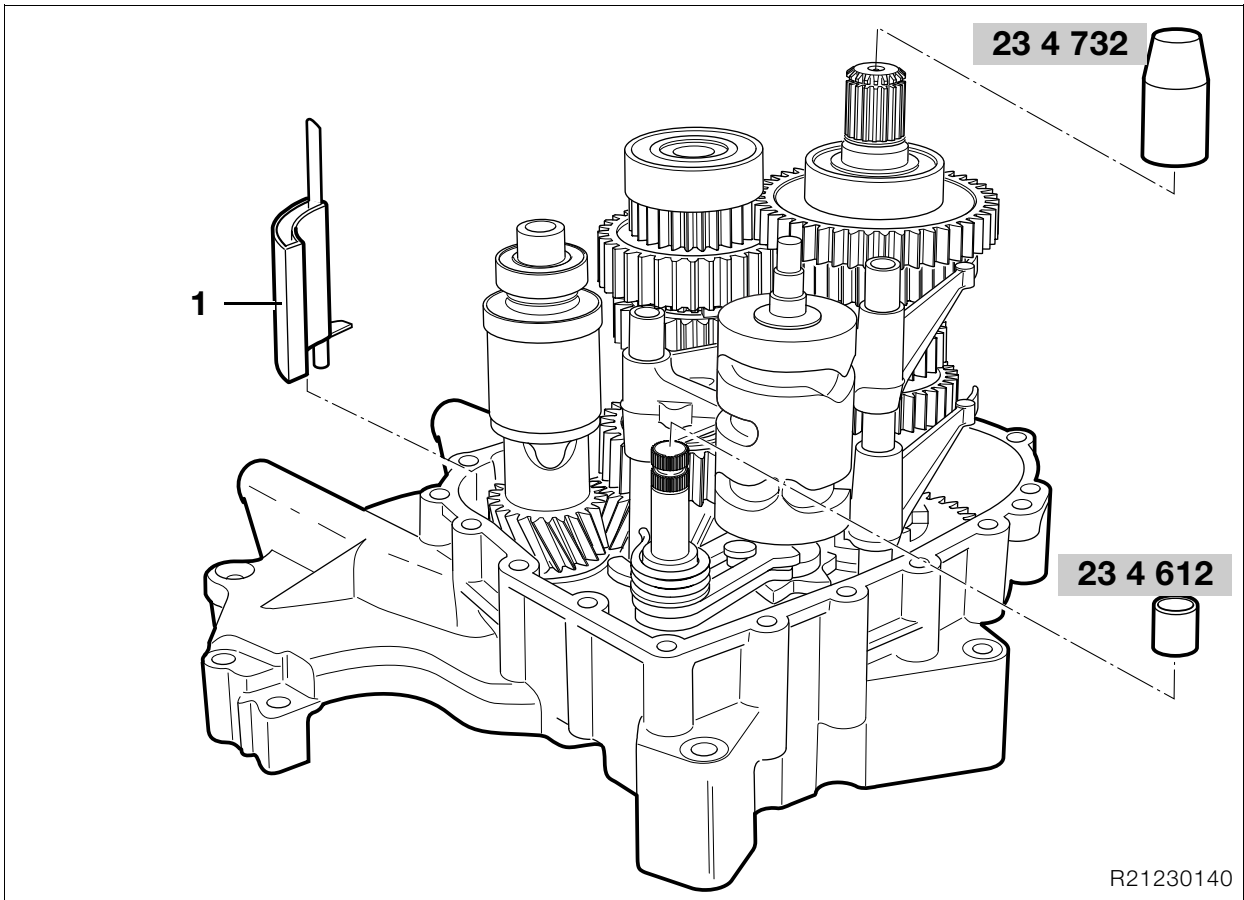

R21230140

Installing gearbox housing

- Install the dowel pins in cover and in housing, but do not drive the pins fully home.
- Install breather tube (1) in housing cover.

Caution:

Clean and de-grease the sealing faces. The sealing compound sets within 30 minutes; within this time, place the housing in position and screw it down.

- Apply **Loctite 574** sealing compound to the mating face of the cover.
- Place assembly sleeve, **BMW No. 23 4 732**, on the output shaft.
- Place assembly sleeve, **BMW No. 23 4 612**, on the selector shaft.

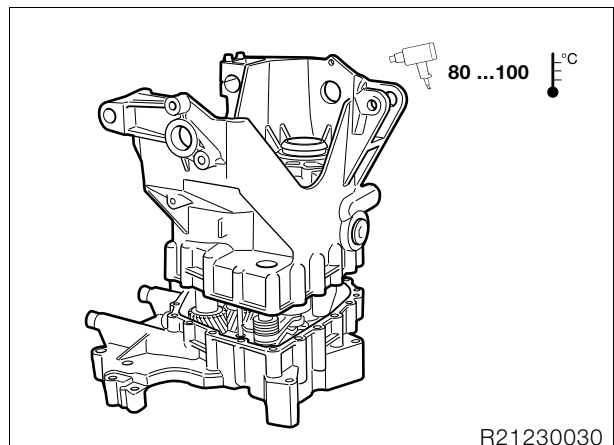

R21230030

- Heat the bearing seats in the housing to 80 ... 100 °C (176 ... 212 °F) and place the housing on the cover.

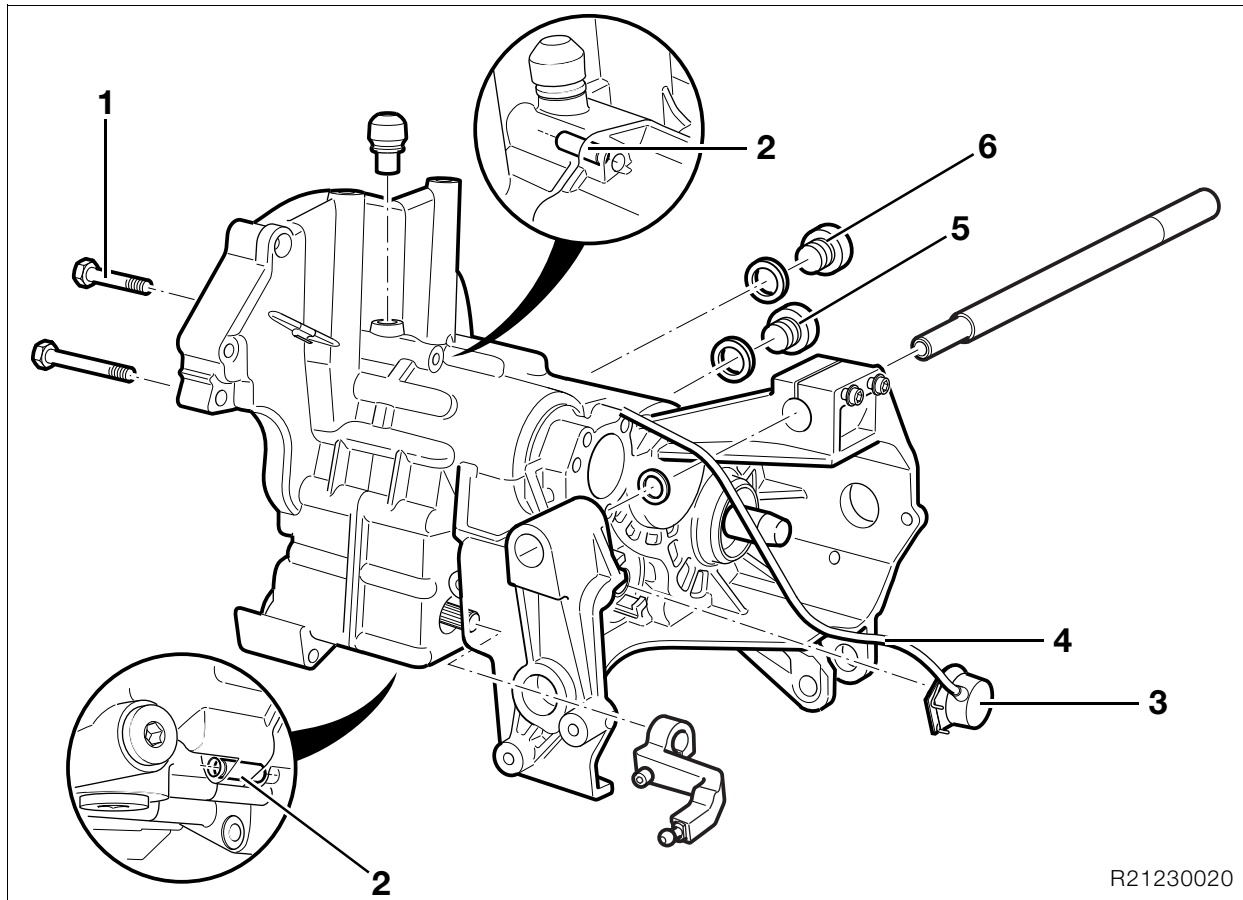

R21230020

- Insert screws (1) and tighten in diagonally opposite sequence.
- Drive home dowel pins (2).
- Install switch of gear indicator (3) and clip cable (4) into position.
- Remove metal particles from the magnet in oil drain plug (5).
- Install the oil drain plug with a new sealing ring.
- Install oil-check and oil filler plug (6) with new sealing ring.

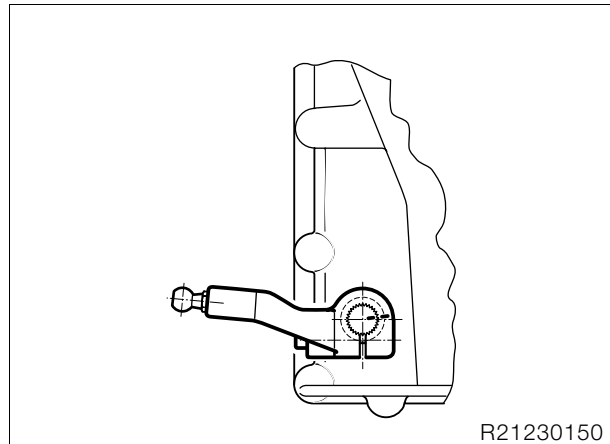

R21230150

- Install shift lever in correct position.



Note:

The shift lever is in the correct position when the mark is aligned with the corresponding mark on the selector shaft.
After assembling the gearbox, perform a functional check.

Tightening torque:

Selector lever to selector shaft..... 9 Nm

31 Front forks

Contents

Page

Technical Data	3
Removing and installing telescopic fork	5
Removing and installing telescopic fork without fork bridge	5
Removing and installing fork bridge	6
Removing and installing pot-type joints	7
Removing and installing angular-contact ball bearing	7
Removing and installing slider tube bridge	8
Removing and installing ball joint in slider tube bridge	8
Checking friction at ball joint/angular-contact ball bearing	8
Disassembling/assembling telescopic fork	9
Disassembling telescopic fork	9
Assembling telescopic fork	9
Measuring telescopic fork	10
Examining slider tube bridge and fork bridge	10
Checking runout of fixed tube	10
Checking runout of slider tube	10
Removing and installing leading link	11
Disassembling/assembling leading link	11
Removing and installing front spring strut	11



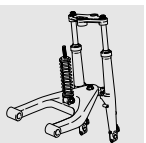

Technical Data		R 1150 GS
Front suspension		
Type	BMW Telelever with external suspension strut	
Telescopic fork		
Front wheel caster in normal-load position (85 kg/187 lbs rider)	mm (in)	115 (4.528)
Steering lock angle	°	42
Total suspension travel	mm (in)	190 (7.48)
Fixed tube surface	Hard chrome plated	
Extl. dia. of fixed fork tubes	mm (in)	35.0 (1.38)
Maximum permissible runout of fixed fork tube	mm (in)	0.4 (0.016)
Telescopic fork oil – approved grades	BMW telescopic fork oil	
Capacity per fork leg	l (Imp.pint/ US quart)	0.47 (0.8275/0.4966)
Suspension strut		
Type	Spring strut with five spring preload settings and two-tube gas shock absorber	



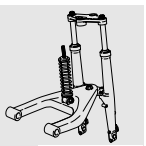

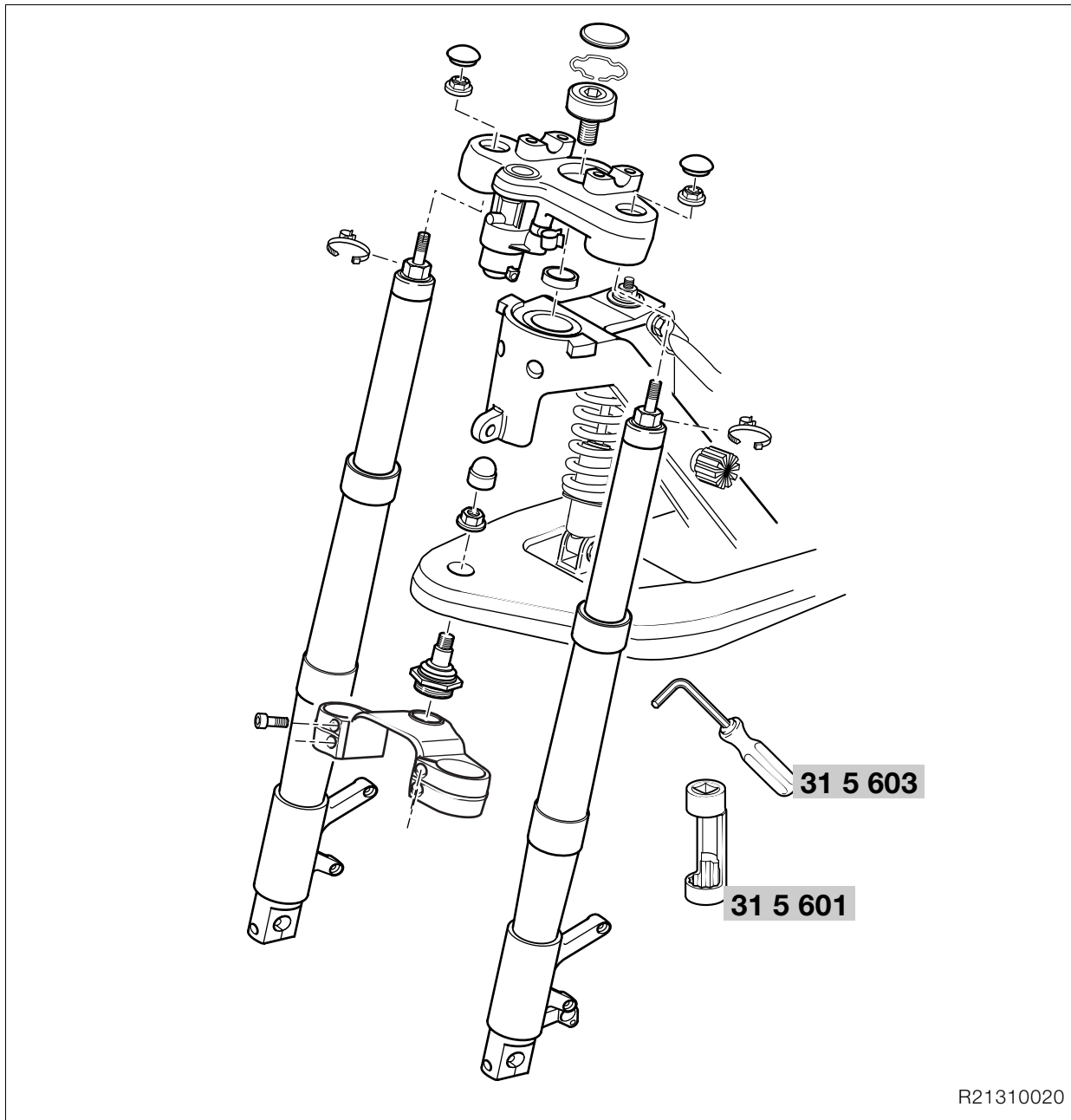

Removing and installing telescopic fork

Removing and installing telescopic fork without fork bridge

- Remove front wheel.
- Remove mudguard.
- **[ABS]** Remove sensor.
- Remove brake line retainer.
- Place a support beneath the telescopic fork.
- Heat leading link mount at front to max. 120 °C (248 °F) and unscrew.
- Remove fasteners (cable ties) securing Bowden cable for starting-speed increase and brake line.



- Remove fastener securing fixed tube in upper fork bridge while holding the hexagon of the fixed tube and then pull the telescopic fork down to remove.

- Installation is the reverse of the removal procedure.
- Tighten the ball joint in the leading link using socket, **BMW No. 31 5 601**, and Allen key, **BMW No. 31 5 603**.

Caution:

To prevent grease from escaping and the ingress of dirt, ensure that sleeve is correctly located on ball joint.

- **[ABS]** Check sensor gap and adjust if necessary.

ABS – sensor gap: 0.45 ... 0.55 mm (0.01771 ... 0.0217 in)

Tightening torque:

Ball joint to leading link
(clean thread + Loctite 2701)..... 130 Nm

Fastener securing fixed tube in fork bridge
(free from oil and grease)..... 45 Nm



Removing and installing fork bridge

- Disengage fuel tank and pull to the rear.
- Disconnect plug of ignition lock.
- Attach the handlebar to a crane and release the fastener securing the handlebar to the fork bridge.
- Remove fasteners (cable ties) securing Bowden cable for starting-speed increase and brake line.

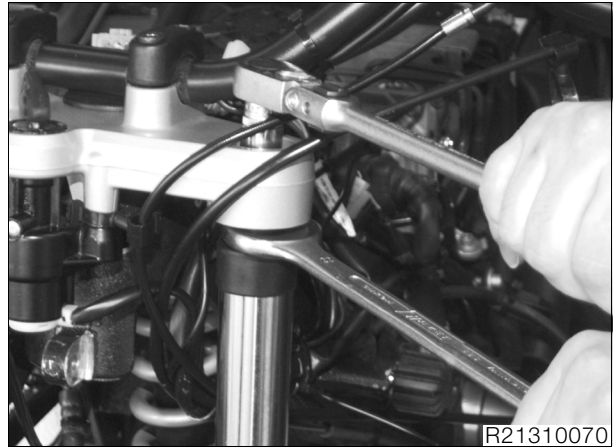

- Remove fastener securing fixed tube in upper fork bridge while holding the hexagon of the fixed tube.
- Remove fastener securing fork bridge to frame.

Note:

The screw pin is a press fit in the angular-contact ball bearing: remove as a complete unit.

- Remove fork bridge.
- Remove ignition/steering lock.
- ➡ Group 51
- Installation is the reverse of the removal procedure.

Caution:

Align the punch mark on the handlebar with the gap between the clamp blocks.

Tightening torque:

Fastener securing fork bridge to frame
(clean thread + Loctite 243)..... 130 Nm
Fastener securing fork bridge to fixed tube
(free from oil and grease)..... 45 Nm
Handlebar to fork bridge 21 Nm

Removing and installing pot-type joints

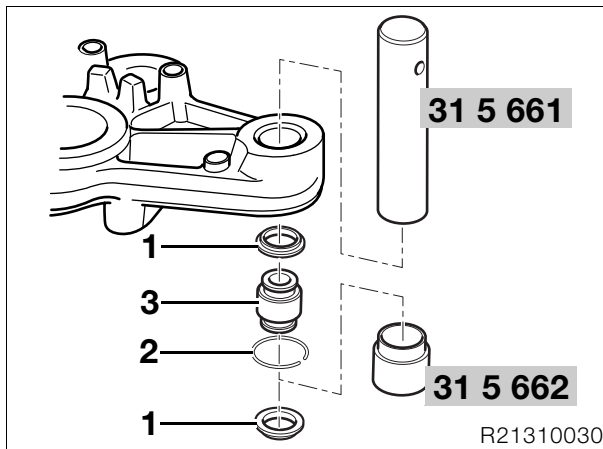

- Remove dust covers (1).
- Remove snap ring (2).
- Press out pot-type joint (3) with mandrel, **BMW No. 31 5 661**, and sleeve, **BMW No. 31 5 662**.

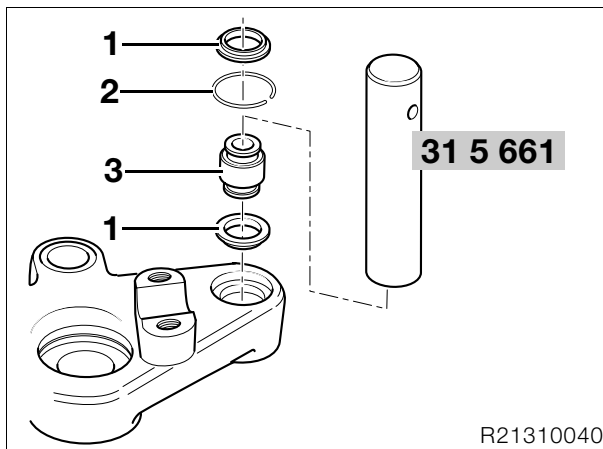

- Press in pot-type joint (3) with mandrel, **BMW No. 31 5 661**.
- Install snap ring (2).
- Install dust covers (1).

Removing and installing angular-contact ball bearing

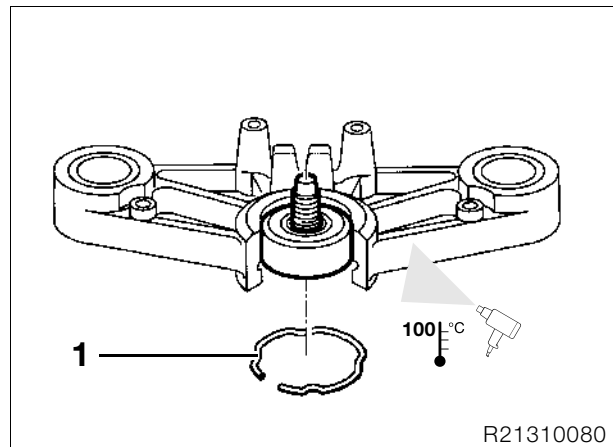

- Remove retaining ring (1).
- Heat fork bridge to approx. 100 °C (212 °F).
- Remove angular-contact ball bearing, if necessary striking lightly with a plastic-faced hammer.

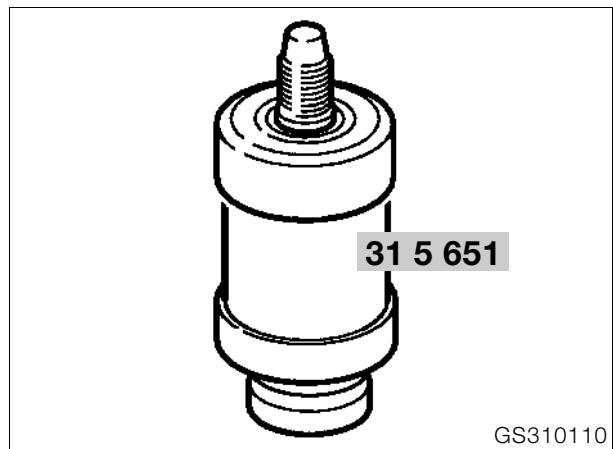

- Press out the threaded pin using a mandrel, **BMW No. 31 5 651**, as a support.



- Press the threaded pin into the angular-contact ball bearing using a mandrel, **BMW No. 31 5 651**, as a support.



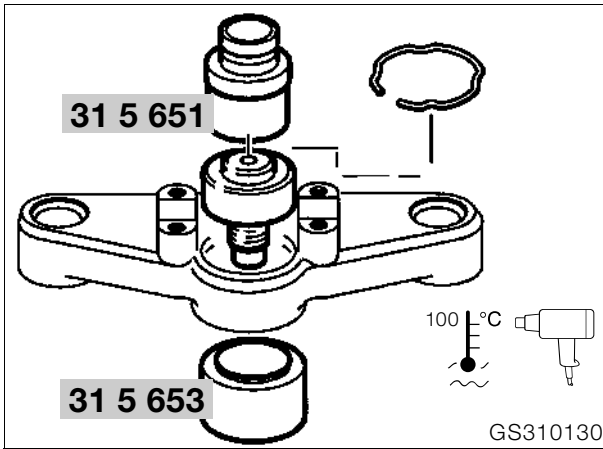

- Heat the fork bridge to 100 °C (212°F) and press in the angular-contact ball bearing with pin, **BMW No. 31 5 651**, and bushing, **BMW No. 31 5 653**.
- Install retaining ring.

Removing and installing slider tube bridge

- Remove telescopic fork.

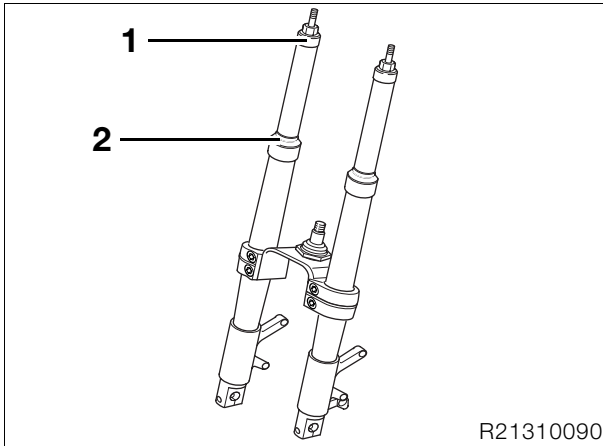

- Remove caps (1).
- Lever out the dust wipers (2).
- Remove fasteners securing slider tube bridge.

Caution:
Do not damage the surfaces.

- Carefully spread the slider tube bridge with a screwdriver and separate it from the slider tubes.
- Installation is the reverse of the removal procedure.

Tightening torque:
Slider tube bridge to slider tube
(clean thread + Loctite 243)..... 25 Nm

Removing and installing ball joint in slider tube bridge

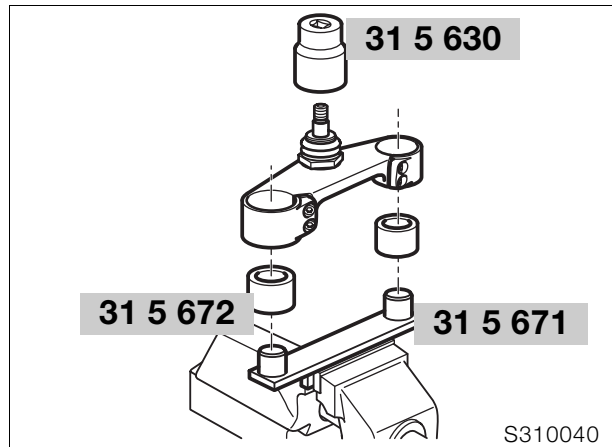

- Mount the slider tube bridge in retaining fixture, **BMW No. 31 5 670**.
- Use w/f 46 socket, **BMW No. 31 5 630**, to release and tighten ball joint.

Tightening torque:
Ball joint to slider tube bridge
(apply Never Seeze to thread) 230 Nm

Checking friction at ball joint/angular-contact ball bearing

- Raise the motorcycle on its main (centre) stand, make sure front wheel is clear of the ground.
- Measure the breakaway moment to left and right from the central position of the handlebar using friction meter, **BMW No. 00 2 570**.

Note:
To determine the friction value, increase torque very slowly.

Friction value:
Measure at room temperature (above 20 °C/68°F)
Nominal value: 1.0 ... 2.0 Nm

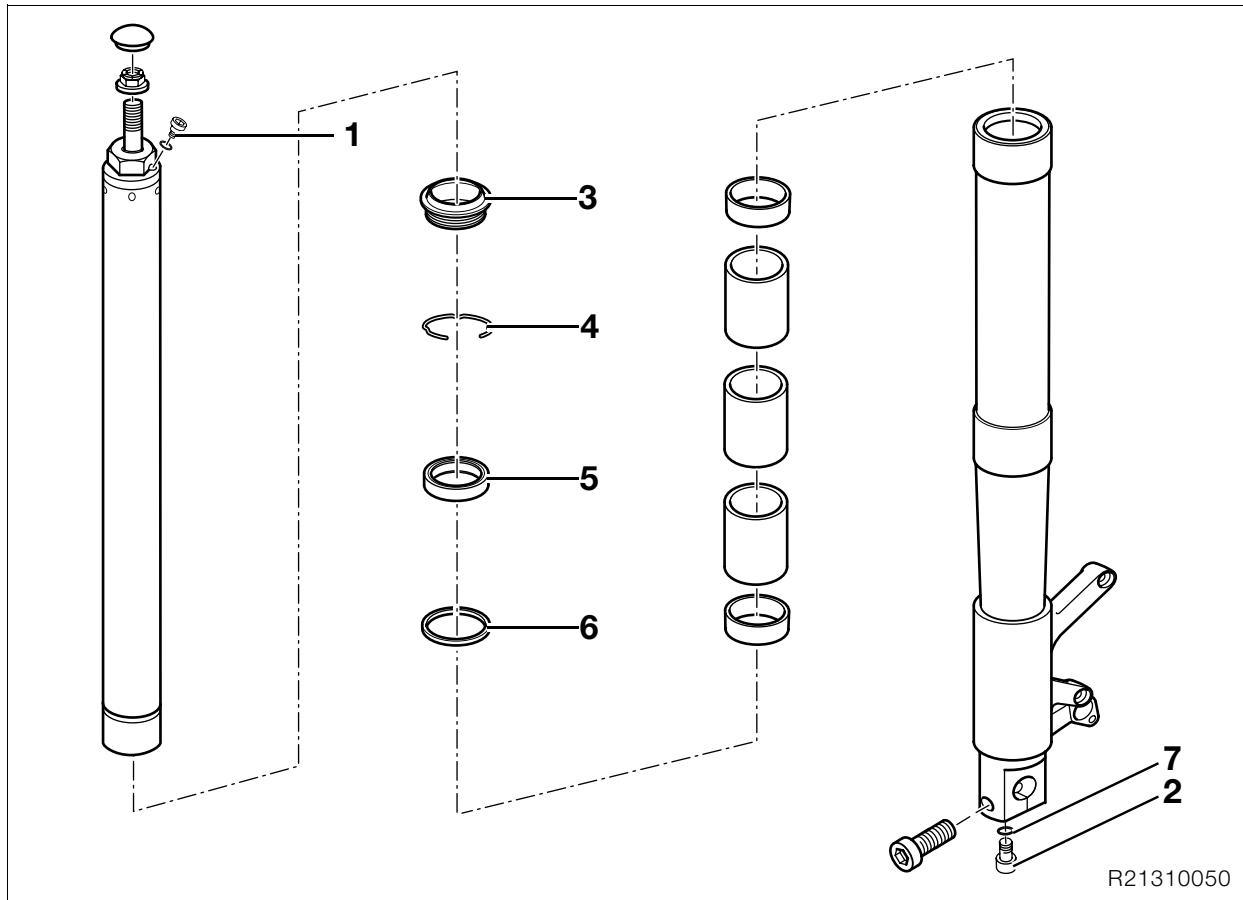

R21310050

Disassembling/assembling telescopic fork

Disassembling telescopic fork

- Remove bleed screw (1).
- Remove oil drain plug (2) and allow the oil to drain out.
- Remove the fixed tube.
- Remove wiper (3) and retaining ring (4).
- Lever out shaft seal (5).

Caution:

Do not damage fork slider tube.

- Remove washer (6).

Assembling telescopic fork

- Install oil drain plug (2).

Caution:

Install new O-ring (7). Check that the O-ring is correctly seated.

- Fill with oil.

Capacity per fixed tube:
 0.47 l (0.82 Imp. pint/0.49 US quart)

Oil grade in telescopic fork:
BMW telescopic fork oil



Note:

No oil changes required during services: unit is maintenance-free.

- Install fixed tube.
- Install washer (6).
- Push the lightly oiled shaft sealing ring fully up to the stop on the slider tube, then press home by tapping lightly and using threaded bush, **BMW No. 31 5 611**, expander, **BMW No. 31 5 612**, and reducing adapter, **BMW No. 31 5 613**.
- Install retaining ring and dust wiper.
- Insert bleed screw (1).
- Bleed telescopic forks under zero load.



Tightening torque:

Screw plug to fixed fork tube

..... press-fit - do not remove!



Measuring telescopic fork



Caution:

After an accident, always examine the telescopic fork for cracks and signs of damage.

Examining slider tube bridge and fork bridge

- Check slider tube bridge and fork bridge for surface irregularities.



Caution:

Replace slider tube bridge/fork bridge if deformed.

Checking runout of fixed tube

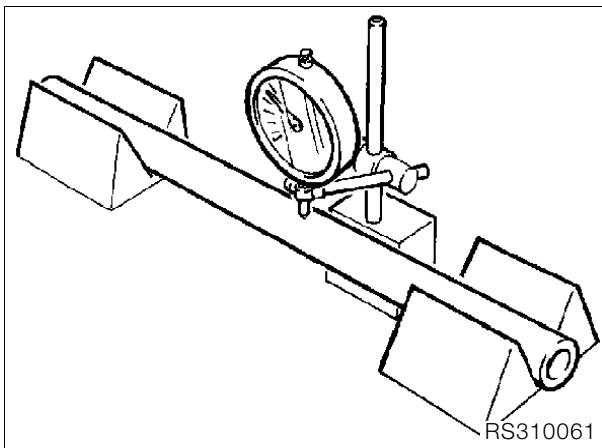

- Place both ends of fixed tube in V-blocks.
- Rotate fixed tube slowly and check with dial gauge.



Caution:

Do not straighten distorted fixed tubes: always replace them.

Permissible runout: 0.4 mm (0.016 in)

Checking runout of slider tube

- New fixed tube must slide freely into slider tube without catching.



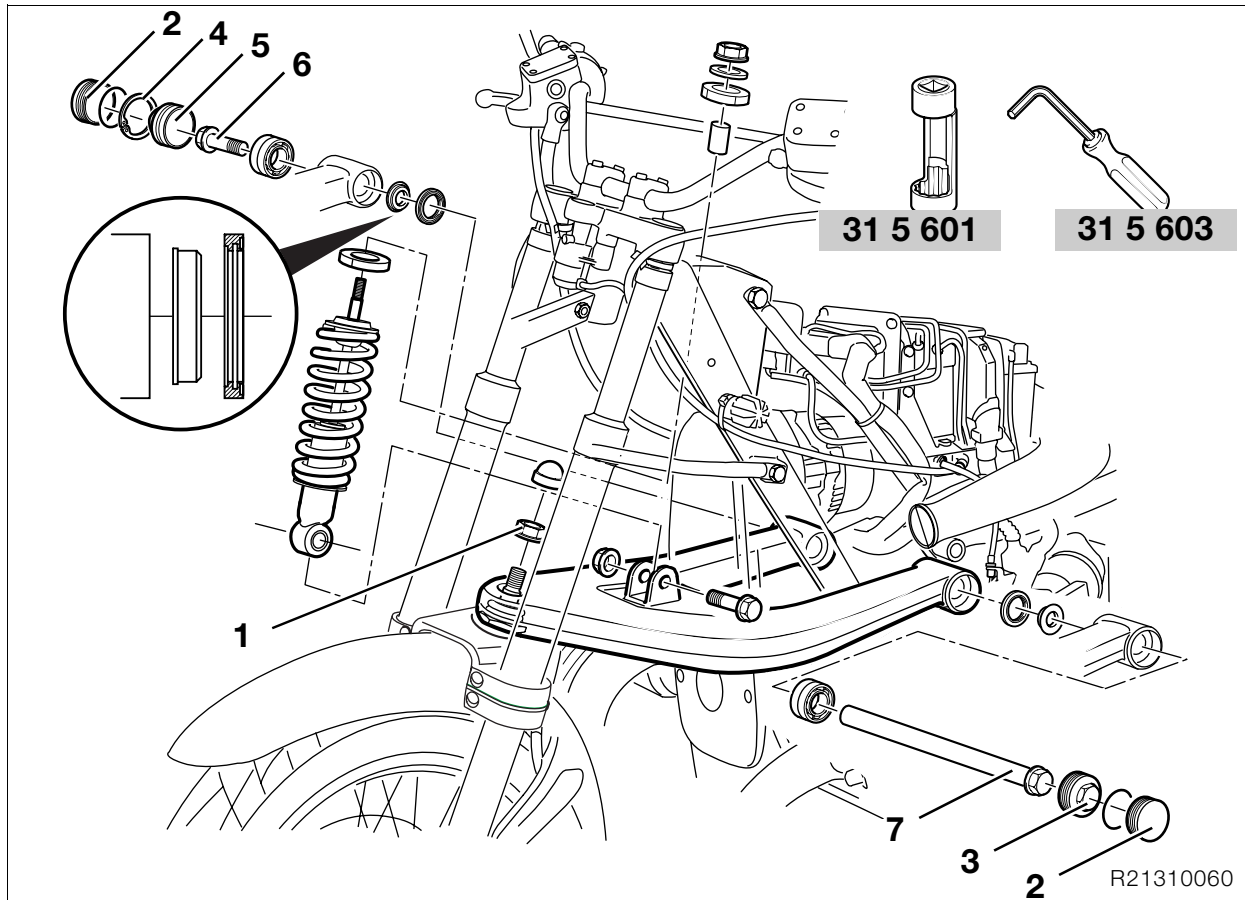

Removing and installing leading link

- Disengage spring strut at bottom.
- Heat ball joint mount (1) at leading link to max. 120 °C (248 °F) and remove it.
- Remove covers (2) from leading link pivots.
- Disconnect the left air intake pipe from the cylinder head.
- Remove left screw cap (3).
- Remove right retaining ring (4) and retaining cap (5).
- Remove right screw (6) and remove shaft (7) by pulling to the left.
- Pull telescopic fork forwards and carefully remove leading link by pulling forwards.



Caution:

Protect parts against scratching; mask off if necessary.

- Installation is the reverse of the removal procedure.
- Apply a light coating of grease to the shaft before installing.
- Tighten the ball joint in the leading link using socket, **BMW No. 31 5 601**, and Allen key, **BMW No. 31 5 603**.



Tightening torque:

Leading link to engine on right 73 Nm
 Left screw cap (coat thread lightly with Never Seeze)..... 42 Nm
 Leading link to ball joint (use a new nut or clean thread + Loctite 2701) 130 Nm
 Spring strut to leading link..... 50 Nm

Disassembling/assembling leading link

- Press the bearing out/in with a suitable tool.



Caution:

Always install bearing by applying pressure to outer race.

Removing and installing front spring strut



Tightening torque:

Spring strut to frame 43 Nm
 Spring strut to leading link..... 50 Nm



32 Steering

Contents

Page

Technical Data	3
Removing and installing left handlebar fitting	5
Removing and installing right handlebar fitting	6
Removing and installing brake piston in handlebar fitting	7
Removing and installing clutch piston in handlebar fitting	8
Checking and adjusting operating clearance at front brake/clutch levers	9
Front brake	9
Clutch	9
Removing and installing handlebar	10
Removing and installing Bowden-cable divider, Bowden cable for throttle actuation and starting-speed increase	11
Disassembling Bowden-cable divider	12

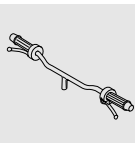

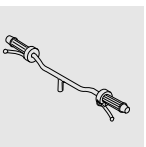

Technical Data		R 1150 GS
Steering lock angle	°	2 x 42
Steering head tube dia.	mm (in)	22 (0.866)
Width of handlebar with weights	mm (in)	903 (35.551)

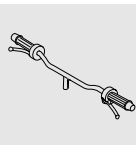

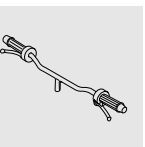

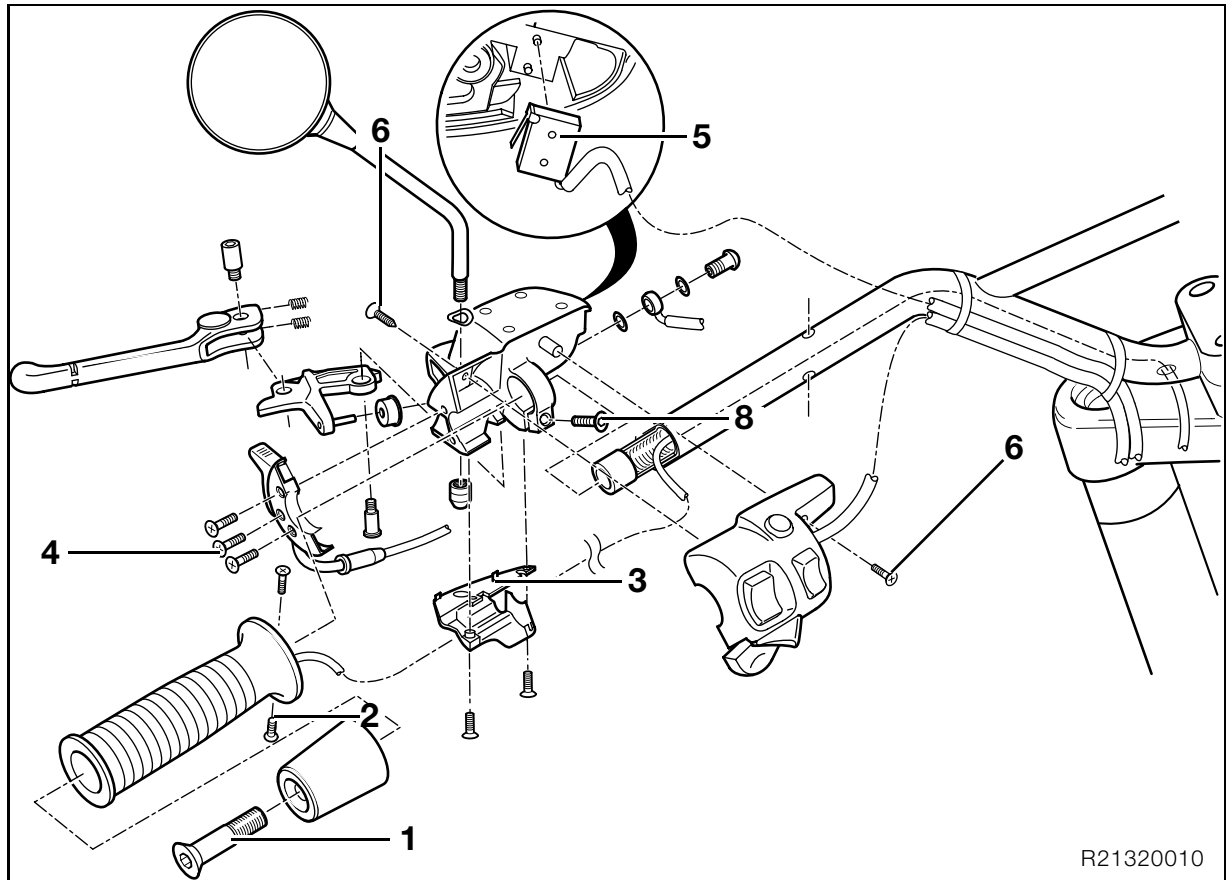

Removing and installing left handlebar fitting

- Disengage fuel tank and pull to the rear.
- Remove securing screw (1) and remove handlebar weight.
- Pull off the grip.
- **(Heated grips)** Disconnect plug of grip heating.
- **(Heated grips)** Release cable shoe in connection.
- Remove lower plastic cover (3) on handlebar fitting.
- Remove screw (4) securing lever for starting-speed increase.
- Disengage Bowden cable for starting-speed increase.
- Remove clutch switch (5).
- Remove mirror.
- Remove screws (6) securing multi-function switch.

Caution:

Do not allow brake fluid to come into contact with painted parts of the motorcycle as brake fluid destroys paint.

- Drain the clutch operating system.
- Disconnect clutch line from handlebar fitting.
- Loosen the multi-function screw (8) for the clutch fitting and remove the fitting.
- Pull off the multi-function switch plug.
- Pull off the clutch switch plug.
- Installation is the reverse of the removal procedure.



Note:

Align the clamp joint line with the punch mark on the handlebar.

- Fill and bleed the clutch operating system.



Tightening torque:

Clutch line to clutch lever fitting 14 Nm
 Handlebar weight to handlebar 21 Nm

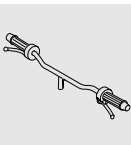

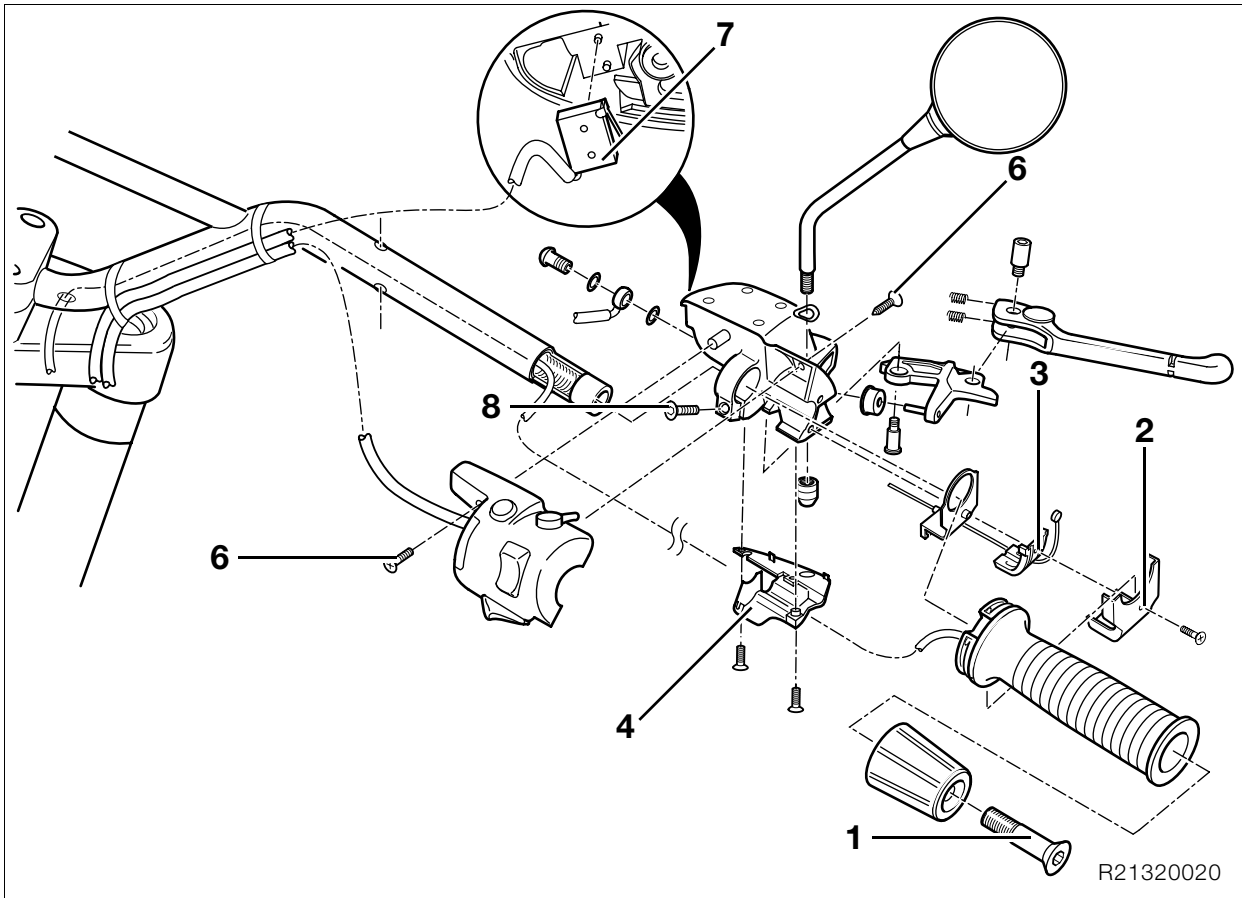

Removing and installing right handlebar fitting

- Disengage fuel tank and pull to the rear.
- Remove securing screw (1) and remove handlebar weight.
- Remove throttle twistgrip cover (2).
- Back off the adjuster screw for the throttle cable and disengage the Bowden cable.
- Remove guide (3) of throttle cable.
- Remove lower plastic cover (4) on handlebar fitting.
- Remove mirror.
- Remove screws (6) securing multi-function switch.
- Pull off the throttle twistgrip.
- **(Heated grips)** Disconnect plug of grip heating.
- **(Heated grips)** Release cable shoe in connection.
- Pull off the brake light switch (7).

Caution:

Do not allow brake fluid to come into contact with painted parts of the motorcycle as brake fluid destroys paint.

- Drain the brake system.
- Disconnect brake line from handlebar fitting.
- Loosen the retaining screw for the brake lever fitting (8) and remove the fitting.
- Pull off the multi-function switch plug.
- Pull off the brake light switch plug.
- Installation is the reverse of the removal procedure.



Note:

Align the clamp joint line with the punch mark on the handlebar.

- Fill and bleed the brake system.



Note:

There must always be a gap of at least 1 mm (0.039 in) between throttle twistgrip and handlebar weight (clearance for movement).



Tightening torque:

Brake hose to brake lever fitting 18 Nm
 Handlebar weight to handlebar 21 Nm

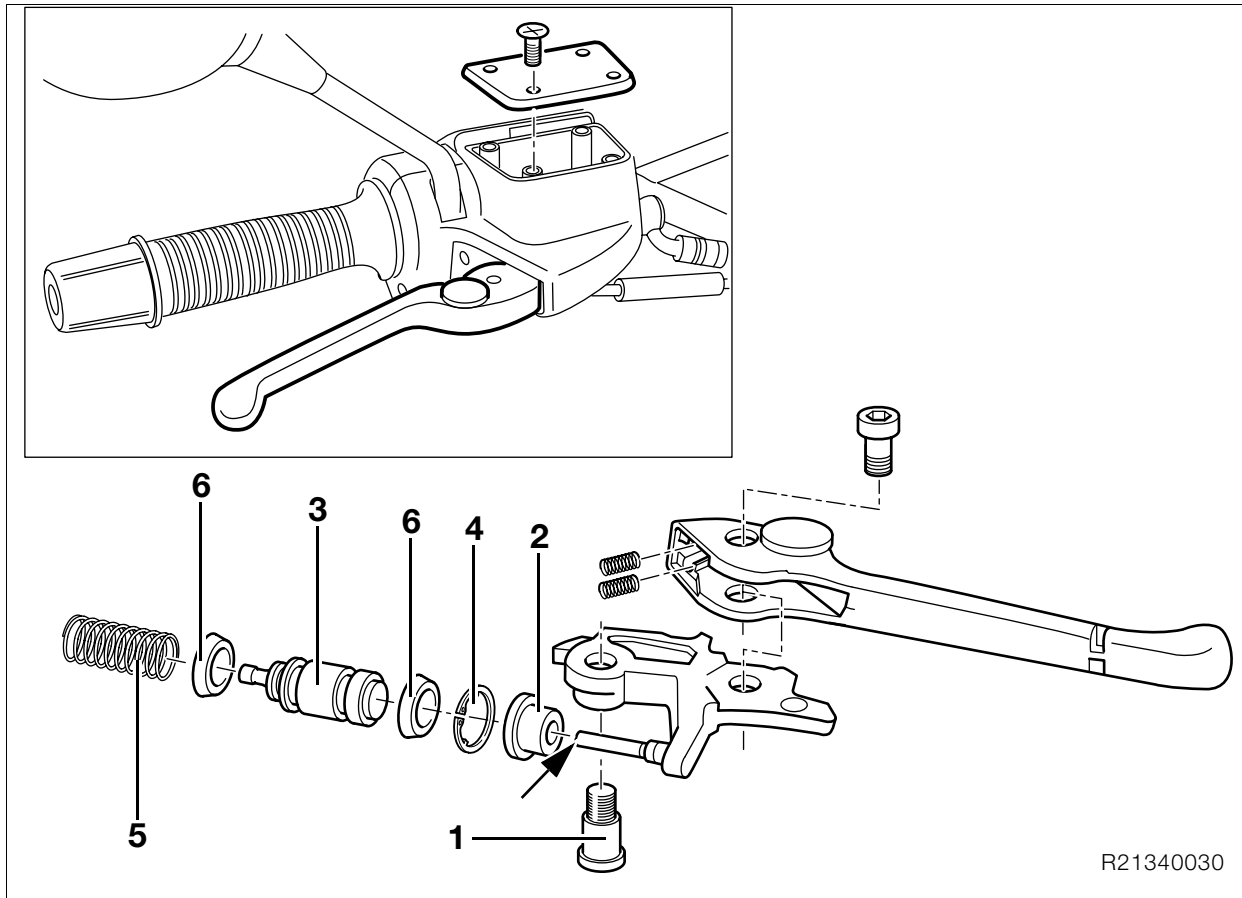

R21340030

Removing and installing brake piston in handlebar fitting

- Drain the brake system.

Caution:

Do not allow brake fluid to come into contact with painted parts of the motorcycle as brake fluid destroys paint.

- Remove throttle twistgrip cover.
- Remove the lower section of the brake lever fitting.
- Remove pivot screw (1) for lever.
- Remove rubber boot (2).

Caution:

Note that brake piston (3) is spring-loaded.

- Carefully press back brake piston (3) and remove retaining ring (4).
- Remove brake piston (3) with spring (5).
- Installation is the reverse of the removal procedure: pay particular attention to the following.
- Prior to installation, coat the piston and the boots (6) with brake fluid.

Caution:

Sealing lips of the boots (6) toward the pressure chamber.

- Prior to installation, carefully press back the brake piston using an Allen key with T-bar handle, for example.
- Use cranked-tip snap-ring pliers to install the retaining ring.
- Apply a light coat of **Optimoly MP 3** to the pressure pin (arrow) on the lever.

Caution:

When installing the brake lever, make sure that the metal tab on the brake-light switch is correctly positioned (otherwise switch will not work).

- Fill and bleed the brake system.
- Check operating clearance and adjust if necessary.

➔ see Page 32.9

Tightening torque:

Pivot screw, handlebar lever (1) 11 Nm
(Tuflok Blue thread-locking compound; screw can be released and tightened a number of times)

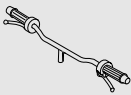

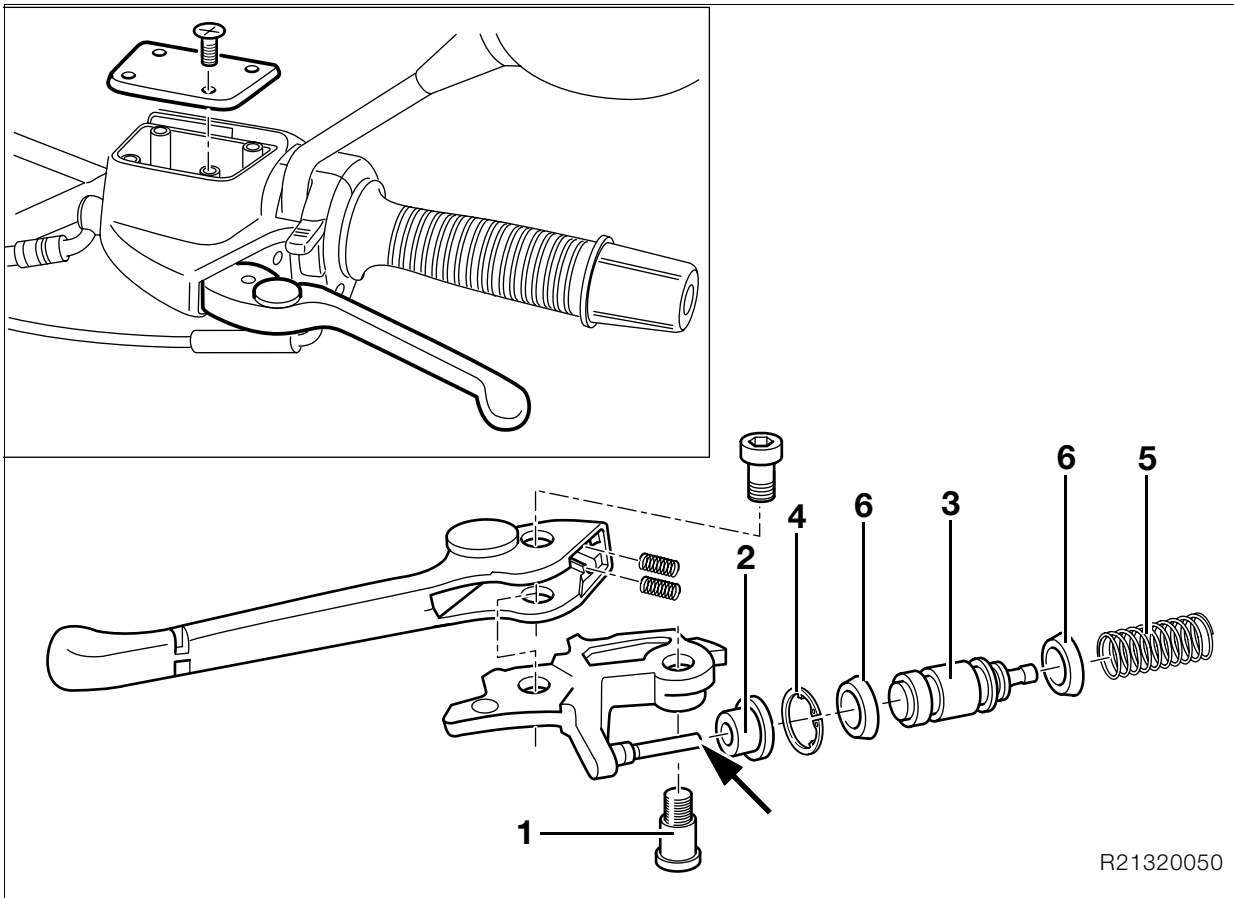

R21320050

Removing and installing clutch piston in handlebar fitting

- Drain the clutch operating system.

⚠ Caution:

Do not allow brake fluid to come into contact with painted parts of the motorcycle as brake fluid destroys paint.

- Remove the lower section of the clutch lever fitting.
- Remove the handlebar weight.
- Remove the grip.
- **(Heated grips)** Release the grip and pull it outwards.
- Release the cold-start actuator and pull it outwards.
- Remove pivot screw (1) of lever and remove the lever.
- Remove rubber boot (2).

⚠ Caution:

Note that clutch piston (3) is spring-loaded.

- Carefully press back clutch piston (3) and remove retaining ring (4).
- Remove clutch piston (3) with spring (5).
- Installation is the reverse of the removal procedure: pay particular attention to the following.
- Prior to installation, coat the piston and the boots (6) with brake fluid.

⚠ Caution:

Sealing lips of the boots (6) toward the pressure chamber.

- Prior to installation, carefully press back the clutch piston using an Allen key with T-bar handle, for example.
- Use cranked-tip snap-ring pliers to install the retaining ring.
- Apply a light coat of **Optimoly MP 3** to the pressure pin (arrow) on the lever.

⚠ Caution:

When installing the clutch lever, make sure that the metal tab on the microswitch is correctly positioned (otherwise switch will not work).

- Fill and bleed the clutch operating system.
- Check operating clearance and adjust if necessary.

➡ see Page 32.9

⚠ Tightening torque:

Pivot screw, handlebar lever (1) 11 Nm (Tuflok Blue thread-locking compound; screw can be released and tightened a number of times)

Checking and adjusting operating clearance at front brake/clutch levers

Front brake

- Remove cover from throttle-cable relay.
- Remove the lower section of the brake lever fitting.

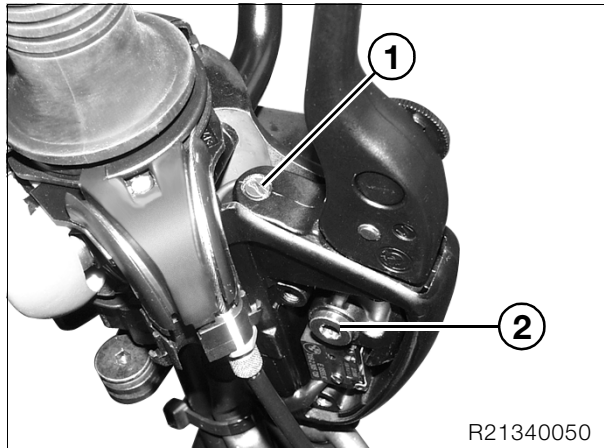

- Back off adjusting screw (1).



Note:

Thread is secured with Loctite, if necessary heat slightly prior to facilitate removal.

- Remove pivot screw (2) of lever and remove the lever.
- Clean and degrease the threads of the adjusting screw.
- Coat the threads of the adjusting screw with **Loctite 648** or **Loctite 270** and screw it a few turns into the lever.
- Apply a light coat of **Optimoly MP 3** to the pressure pin of the adjusting screw.
- Install the lever, making sure that the metal tab on the microswitch is correctly positioned.
- Tighten the adjusting screw until the lever has zero play.
- Tighten the adjusting screw **another full turn**.
- Apply sealing lacquer to the adjusting screw.
- Fully assemble the fitting.



Tightening torque:

Pivot screw, handlebar lever (2) 11 Nm (Tuflok Blue thread-locking compound; screw can be released and tightened a number of times)

Clutch

- Remove the lower section of the clutch lever fitting.
- Remove the handlebar weight.
- Remove the grip.
- **(Heated grips)** Release the grip and pull it outwards.
- Release the cold-start actuator and pull it outwards.
- Back off the adjusting screw.



Note:

Thread is secured with Loctite, if necessary heat slightly prior to facilitate removal.

- Remove the pivot screw of lever and remove the lever.
- Clean and degrease the threads of the adjusting screw.
- Coat the threads of the adjusting screw with **Loctite 648** or **Loctite 270** and screw it a few turns into the lever.
- Apply a light coat of **Optimoly MP 3** to the pressure pin of the adjusting screw.
- Install the lever, making sure that the metal tab on the microswitch is correctly positioned.
- Tighten the adjusting screw until the lever has zero play.
- Tighten the adjusting screw **another half turn**.
- Apply sealing lacquer to the adjusting screw.
- Fully assemble the fitting.



Tightening torque:

Pivot screw, handlebar lever 11 Nm (Tuflok Blue thread-locking compound; screw can be released and tightened a number of times)

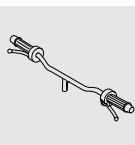

Removing and installing handlebar

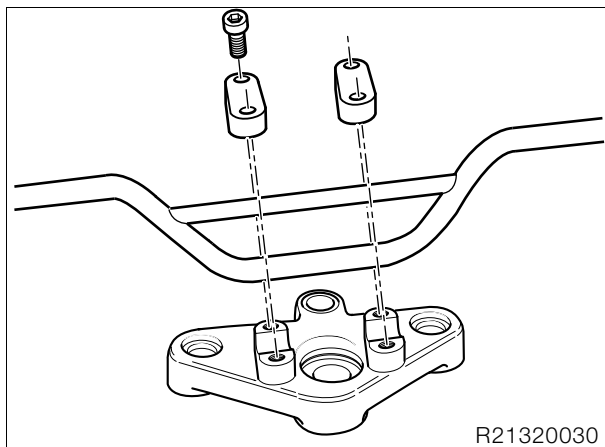

- Remove left and right handlebar fittings.
- Remove handlebar.
- Installation is the reverse of the removal procedure.



Caution:

Make sure that all lines and cables are correctly routed.

Align the punch mark on the handlebar with the gap between the clamp blocks.



Tightening torque:

Clamp to fork bridge 21 Nm
Handlebar weight to handlebar..... 21 Nm

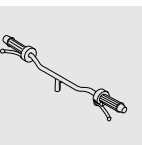

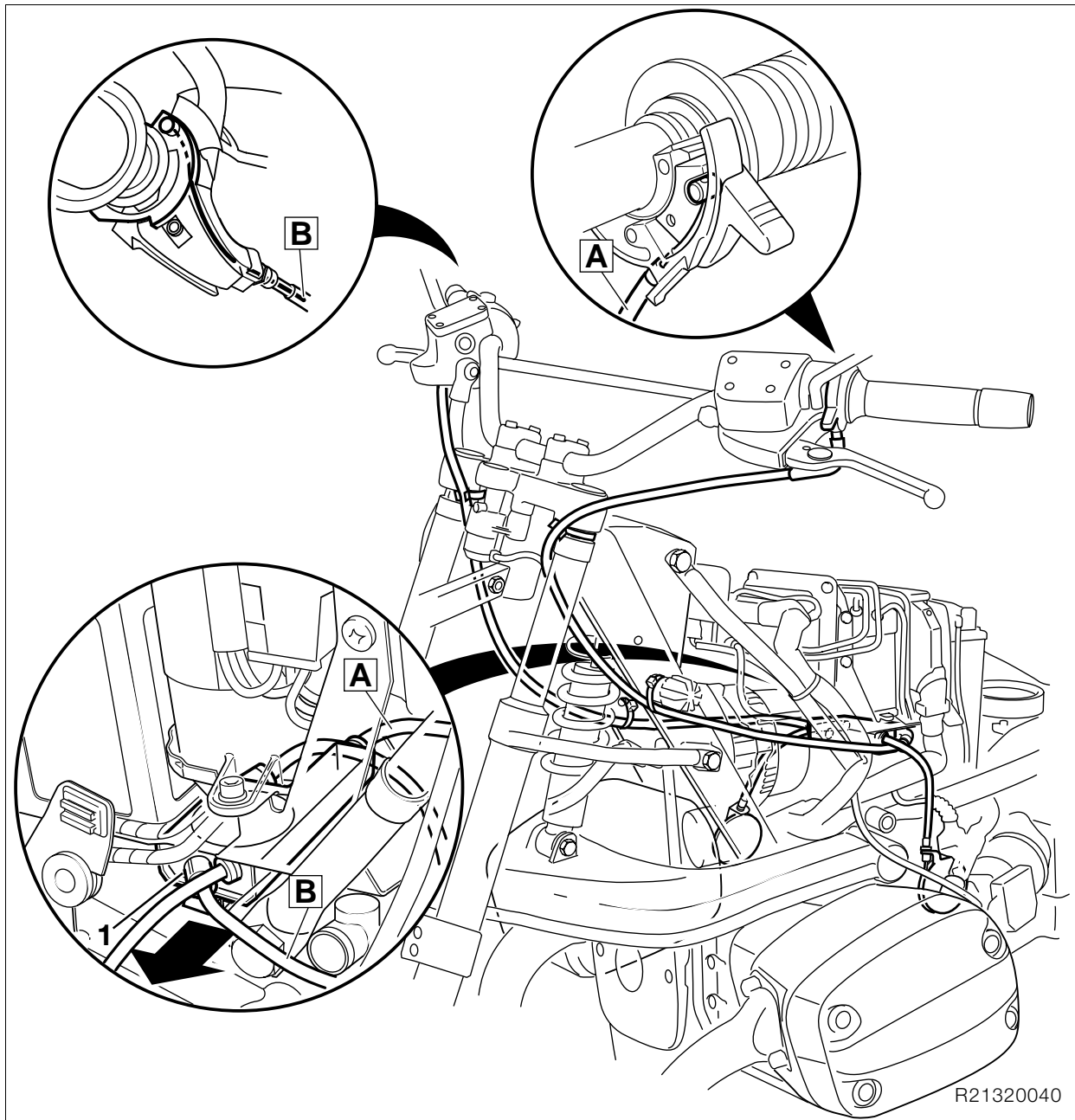

R21320040

Removing and installing Bowden-cable divider, Bowden cable for throttle actuation and starting-speed increase

→ see Group 00

- Disengage fuel tank and pull to the rear.
- Remove actuating cable for starting-speed increase.
- Disengage Bowden cable (A).
- Remove Bowden-cable cover from fitting for throttle actuation.
- Disengage Bowden cable (B).
- Disengage throttle cables from right and left throttle flap stubs.
- Remove cable ties securing Bowden cables.
- Disconnect engine breather line from engine.
- Pull Bowden-cable divider (1) out of holder in direction indicated by arrow.
- Installation is the reverse of the removal procedure.
- If necessary, remove the intake air pipe.
- Adjust Bowden cables.

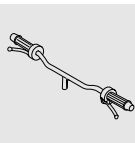

Disassembling Bowden-cable divider

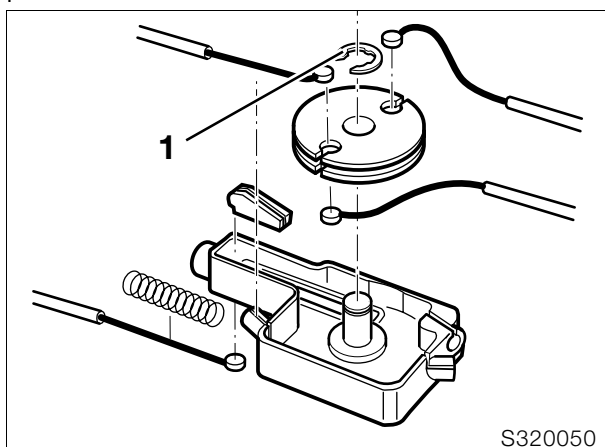

- Remove fasteners of Bowden cables at entry to Bowden-cable divider.
- Remove Bowden cable for starting-speed increase.
- Remove retainer (1) for roller of Bowden-cable divider.
- Remove Bowden cables.
- Installation is the reverse of the removal procedure.



Caution:

Make sure that Bowden cables are free of kinks.

- Adjust Bowden cables.
⇒ see Group 00

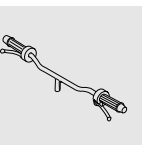

33 Rear wheel drive

Contents

Page

Technical Data	3
Removing, disassembling, reassembling and installing rear wheel drive	5
Removing rear wheel drive	5
Removing and installing taper roller bearing in rear wheel drive	5
Removing input bevel pinion	6
Disassembling input bevel pinion	7
Removing needle roller bearing for input bevel pinion	8
Installing needle roller bearing for input bevel pinion	8
Assembling input bevel pinion	8
Installing input bevel pinion	9
Removing and disassembling crown wheel	11
Assembling and installing crown wheel	12
Shimming input bevel pinion and crown wheel	13
Checking tooth contact pattern	14
Checking and adjusting backlash	15
Shimming housing cover	16
Installing housing cover	16
Installing sliding element	16
Installing rear wheel drive	17
Removing and installing spring strut	18
Removing and installing rear swinging arm	19
Removing rear swinging arm	19
Removing and installing taper roller bearing	20
Removing and installing flexible gaiter	20
Removing drive shaft	20
Checking universal joint for wear	20
Installing drive shaft	20

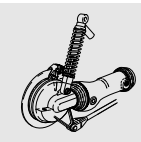

Contents

Page

Installing rear swinging arm21

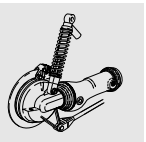

Technical Data		R 1150 GS
Rear wheel drive		
Gear tooth pattern		Klingelnberg-Paloid spiral bevel
Gear ratio		2.82 : 1
	Number of teeth	31 : 11
Backlash	mm (in)	0.07 ... 0.16 (0.0027 ... 0.0063)
Taper roller bearing preload	mm (in)	0.05 ... 0.1 (0.0020 ... 0.0039)
Oil grades		Brand-name hypoid gear oil, SAE 90 GL 5
Capacity		Initial filling/oil changes
	l (Imp.pint/US quart)	up to lower edge of thread in filler neck approx. 0.25 (0.4402/0.2642)
Drive shaft		
Layout		Two-piece shaft with universal joints at each end, central sliding joint and integral torsional vibration damper, enclosed in swinging arm.
Swinging arm		
Swinging arm length	mm (in)	341 (13.4251)
	mm (in)	Total length (to centre of wheel) 506 (19.9212)
Rear suspension		
Suspension strut		Spring strut with single-tube gas-filled shock absorber, steplessly adjustable rebound stage and hydraulically steplessly adjustable spring preload.
Suspension travel	mm (in)	200 (7.88)

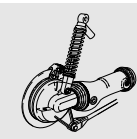

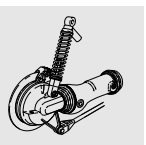

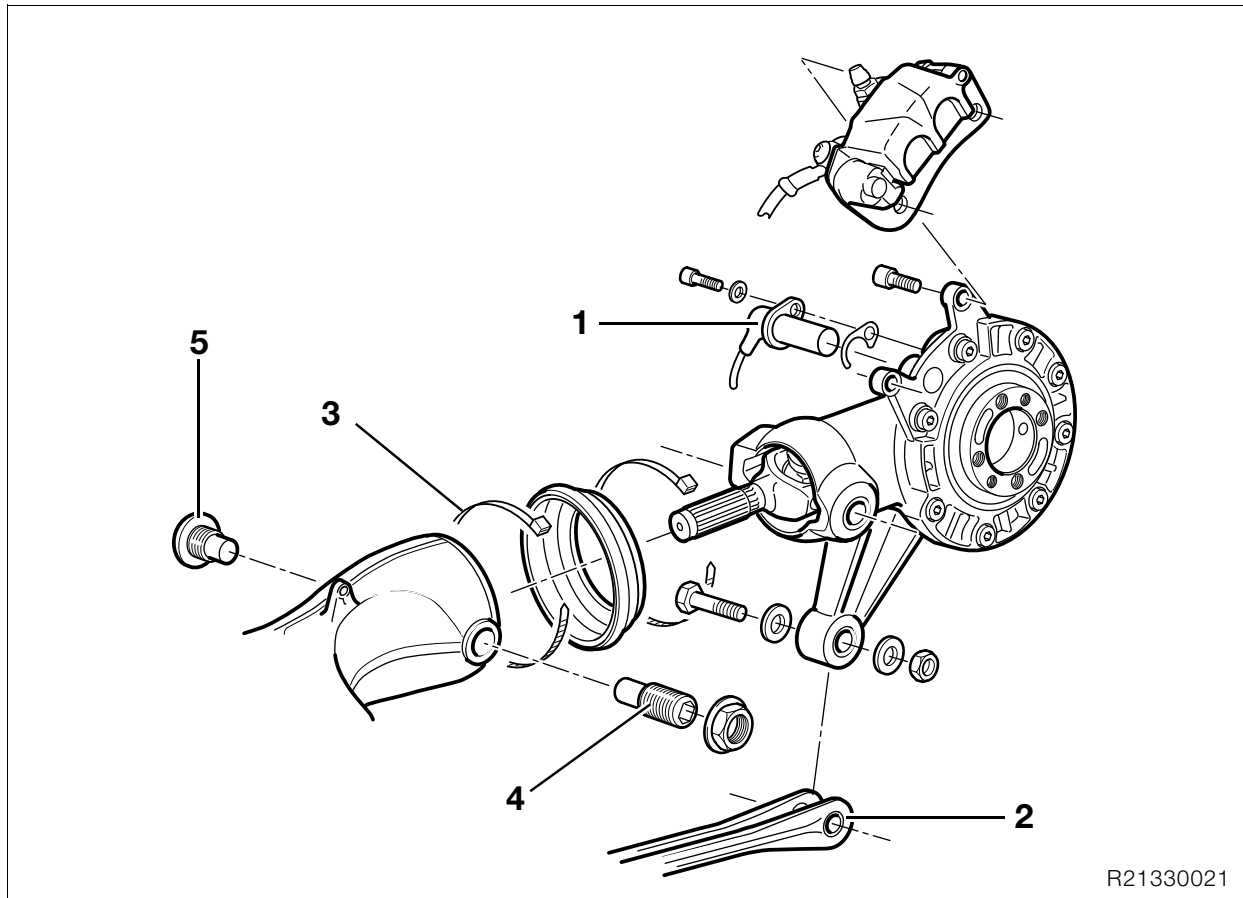

Removing, disassembling, reassembling and installing rear wheel drive

Removing and installing taper roller bearing in rear wheel drive

Removing rear wheel drive

- If necessary, drain the oil from the rear wheel drive.
- Remove rear wheel cover.
- Remove the brake caliper and secure it to the rear frame with a cable strap.
- **[ABS]** Remove sensor (1).
- Remove rear wheel.
- Loosen reaction link (2) at the rear wheel drive.
- Remove retainer (3).
- Push the flexible gaiter to the rear.
- Swinging-arm bearing studs are secured with Loctite: heat to max. 120 °C (248 °F) to release.
- Loosen floating bearing stud bolt (4).
- Loosen fixed bearing stud bolt (5).
- Disengage reaction link from rear wheel drive.
- Remove floating bearing/ fixed bearing stud bolts.



Note:

Note inner races of needle bearings.

- Remove rear-wheel drive from universal shaft.



Note:

Do not lay oil-filled rear-wheel drive on its side prior to installation, as this will cause oil to escape when the motorcycle is on the road (suction effect).

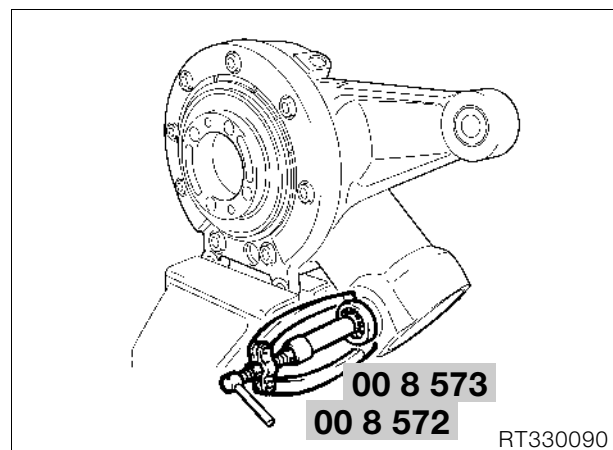

- Remove needle roller bearing with counter-support 22/1, **BMW No. 00 8 572**, and internal puller 21/4, **BMW No. 00 8 573**, with ring support.
- Heat neck of housing to 120 °C (248 °F).
- Press in needle roller bearing with inner race with driver, **BMW No. 36 3 700**.

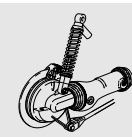

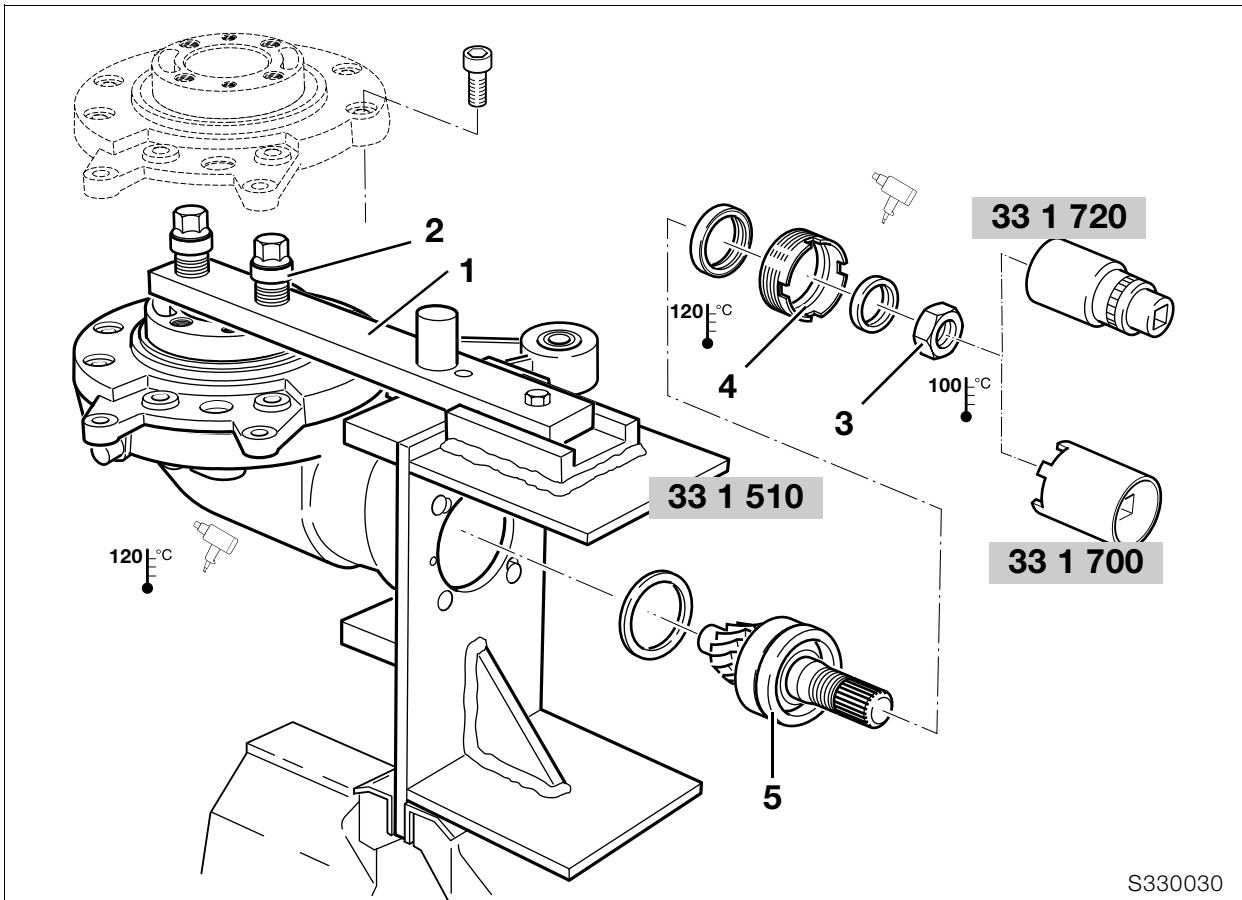

S330030

Removing input bevel pinion

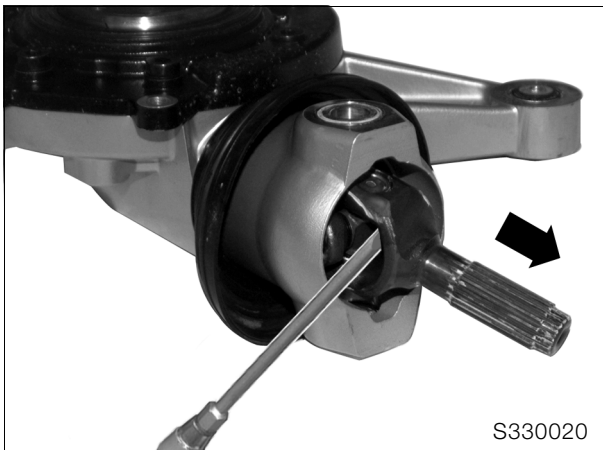

S330020

- Press out splined section of shaft.
- If necessary, remove/install circlip.

- Bolt the rear wheel drive to the retaining fixture, **BMW No. 33 1 510/511**.
- Bolt the locking arm (1) to the retaining fixture.
- Tighten grub screws until they are seated.

Caution:

The grub screws must not project, or the neck of the housing could be damaged.

- Screw threaded bushings (2) down on to the rear wheel drive and secure them with the wheel studs.
- Heat hex nut (3) at the input bevel pinion to 100 °C (212 °F) and unscrew with w/f 36 socket wrench insert and reduction adapter, **BMW No. 33 1 720**.

Note:

If necessary, use cross-handle with two tubular extensions.

- Heat the housing to max. 120 °C (248 °F) and unscrew threaded ring (4) with pin wrench, **BMW No. 33 1 700**.
- To remove the input bevel pinion (5), remove the crown wheel.

➡ See "Removing crown wheel"

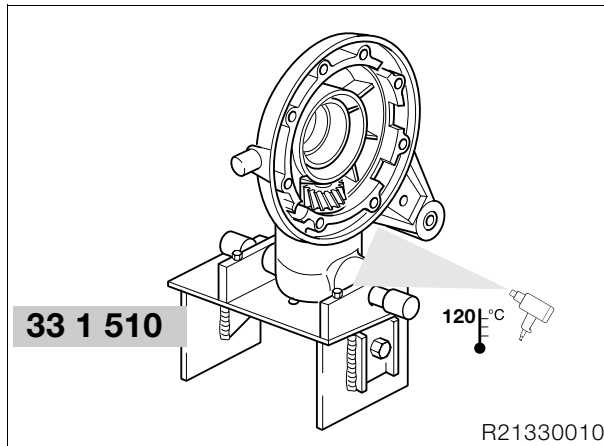

- Place rear wheel drive in position complete with holder.

⚠ Caution:

To prevent the input bevel pinion from being damaged when it falls out, use a soft underlay.

- Heat the housing until the input bevel pinion is released (max. 120 °C/248 °F) and drops out.
- Remove the input bevel pinion and the spacer.

Disassembling input bevel pinion

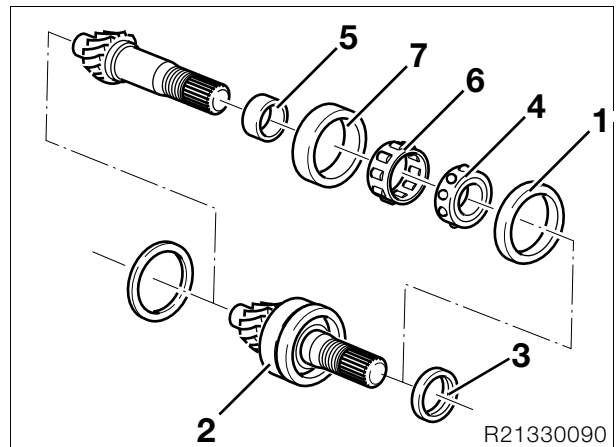

- Remove outer bearing race (1).
- Clamp input bevel pinion (2) into vise with protective jaws (splines facing upwards).

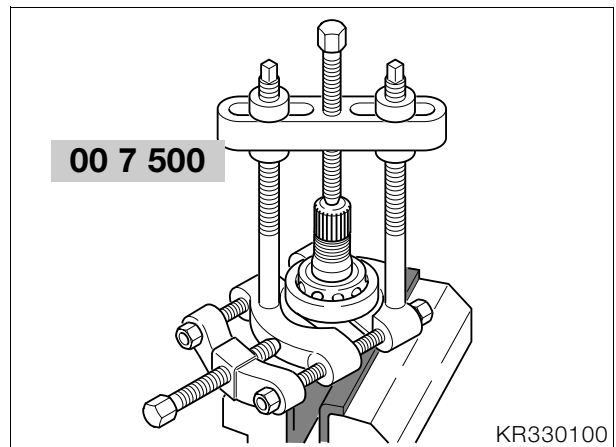

- Using puller, **BMW No. 00 7 500**, pull off both bearings at the same time.
- Remove thrust ring (3).
- Remove ball thrust bearing (4), inner race (5), roller bearing cage (6) and outer race (7).

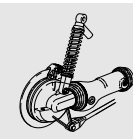

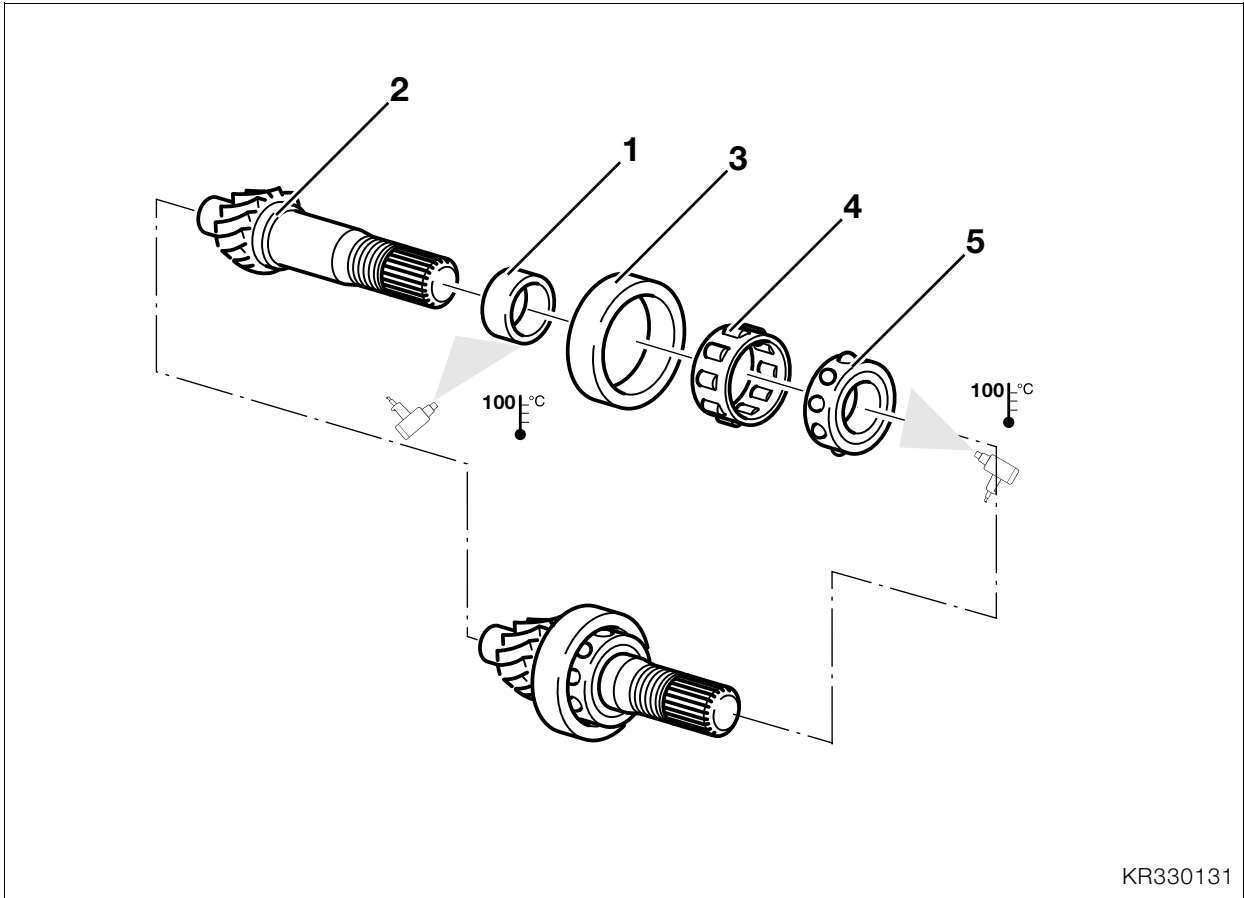

KR330131

Removing needle roller bearing for input bevel pinion

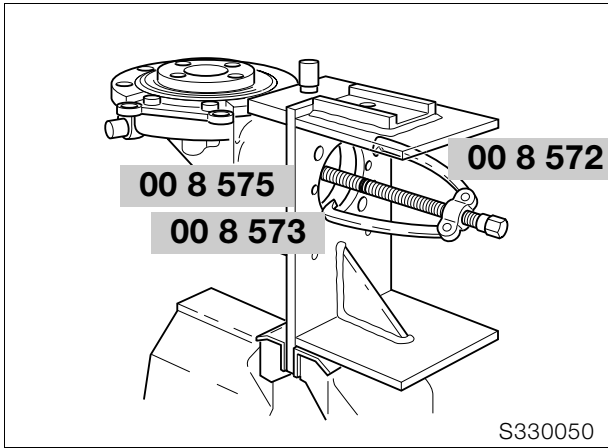

- Heat the housing to 120 °C (248 °F).
- Remove the outer ring of the needle roller bearing using internal puller, **BMW No. 00 8 573**, threaded extension, **BMW No. 00 8 575**, and counter-support, **BMW No. 00 8 572**.

Installing needle roller bearing for input bevel pinion

- Heat the needle roller bearing seat to 100 °C (212°F).
- Press in needle roller bearing using drift or the input bevel pinion.

Assembling input bevel pinion

- Clean the threads of the input bevel pinion.
- Heat the inner race (1) to 100 °C (212°F) and push onto input bevel pinion (2) as far as the stop.
- Push the outer race (3) together with the roller cage (4) on to the inner race.
- Heat ball thrust bearing (5) to 100 °C (212°F) and push fully on to input bevel pinion.
- Allow input bevel pinion to cool down.

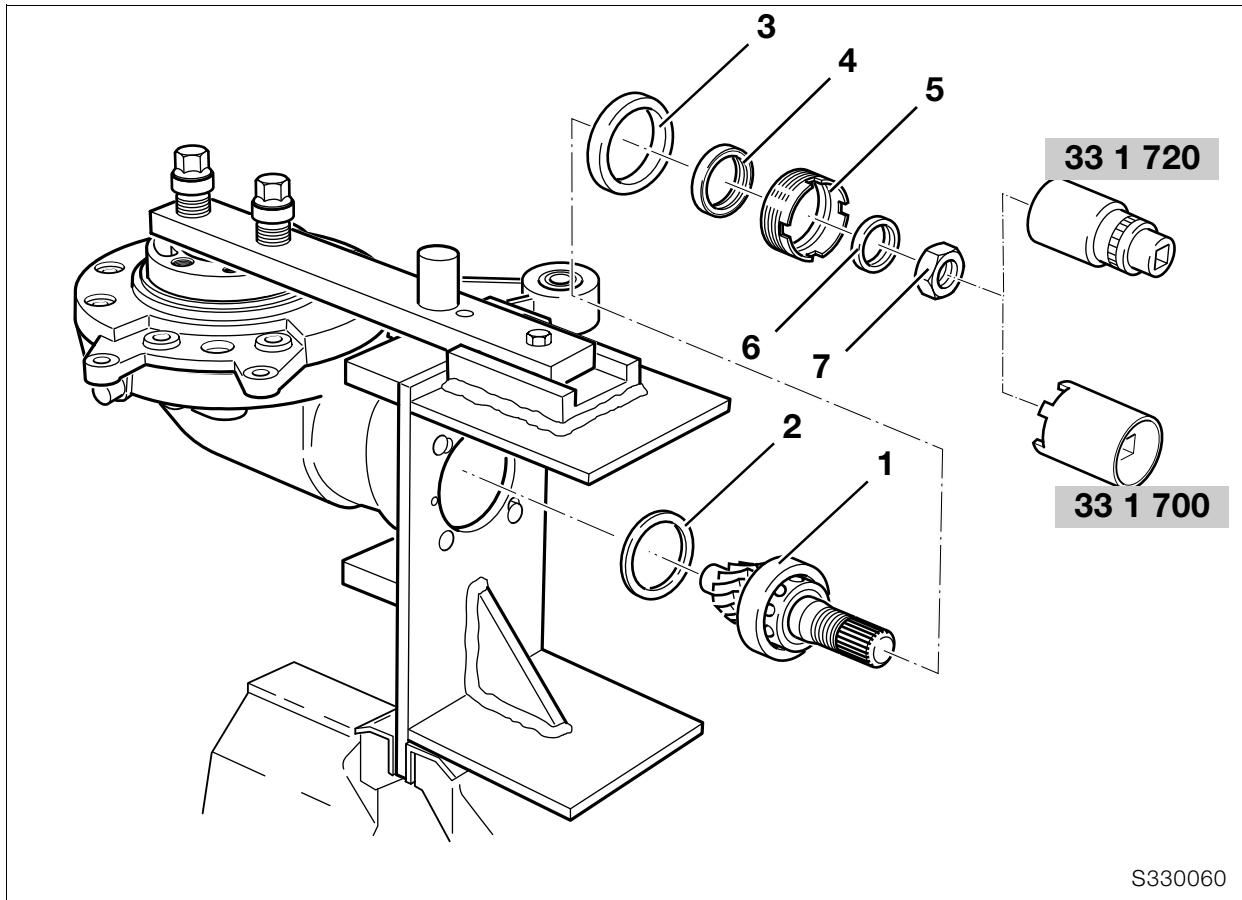

S330060

Installing input bevel pinion

- Clean threads in the housing.

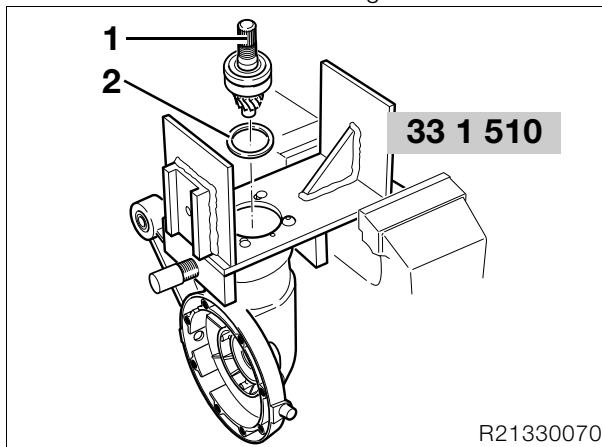

- Clamp holder, **BMW No. 33 1 510**, in the vise in such a way that the input neck of the housing is pointing vertically upward.
- Heat the neck of the housing to max. 120 °C (248 °F).



Note:

Chill input bevel pinion prior to installation in refrigerator/freezer or similar, or use cooling spray.

- Install spacer (2).
- Install input bevel pinion (1) from above.

- Clamp holder, **BMW No. 33 1 510**, in the vise in such a way that the input neck of the housing is pointing forward.
- To secure the input bevel pinion, install the crown gear with housing cover.
- Secure the locating arm to the holder and the rear wheel drive.
- Insert outer race (3).

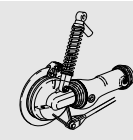

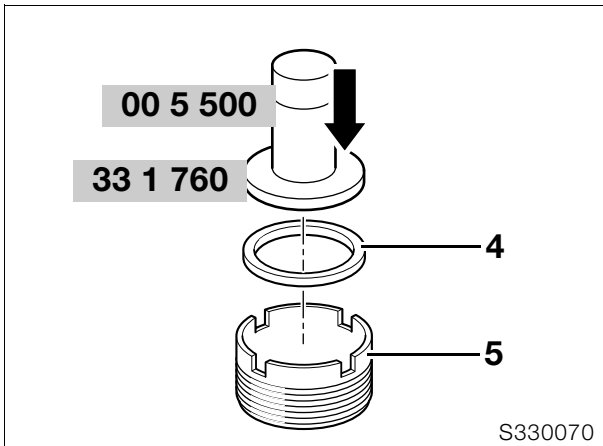

 **Tightening torque:**

Housing cover	35 Nm
Threaded ring (thread cleaned + Loctite 577)	160 Nm
Nut for input bevel pinion (thread cleaned + Loctite 2701).....	200 Nm

- Lightly oil the sealing ring (4) at the sealing lip and round the outer edge.
- Press/drive sealing ring with drift, **BMW No. 33 1 760**, and handle, **BMW No. 00 5 500**, into threaded ring (5).
- Coat the cleaned threaded ring with **Loctite 577** and tighten with pin wrench, **BMW No. 33 1 700**.
- Install thrust ring (6).



Note:

Make sure that the lip of the shaft seal is seated correctly on the thrust ring.

- Tighten hex nut (7) with w/f 36 socket wrench insert and reduction adapter, **BMW No. 33 1 720**.



Caution:

Make sure that the nut does not damage the shaft sealing ring.

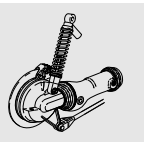

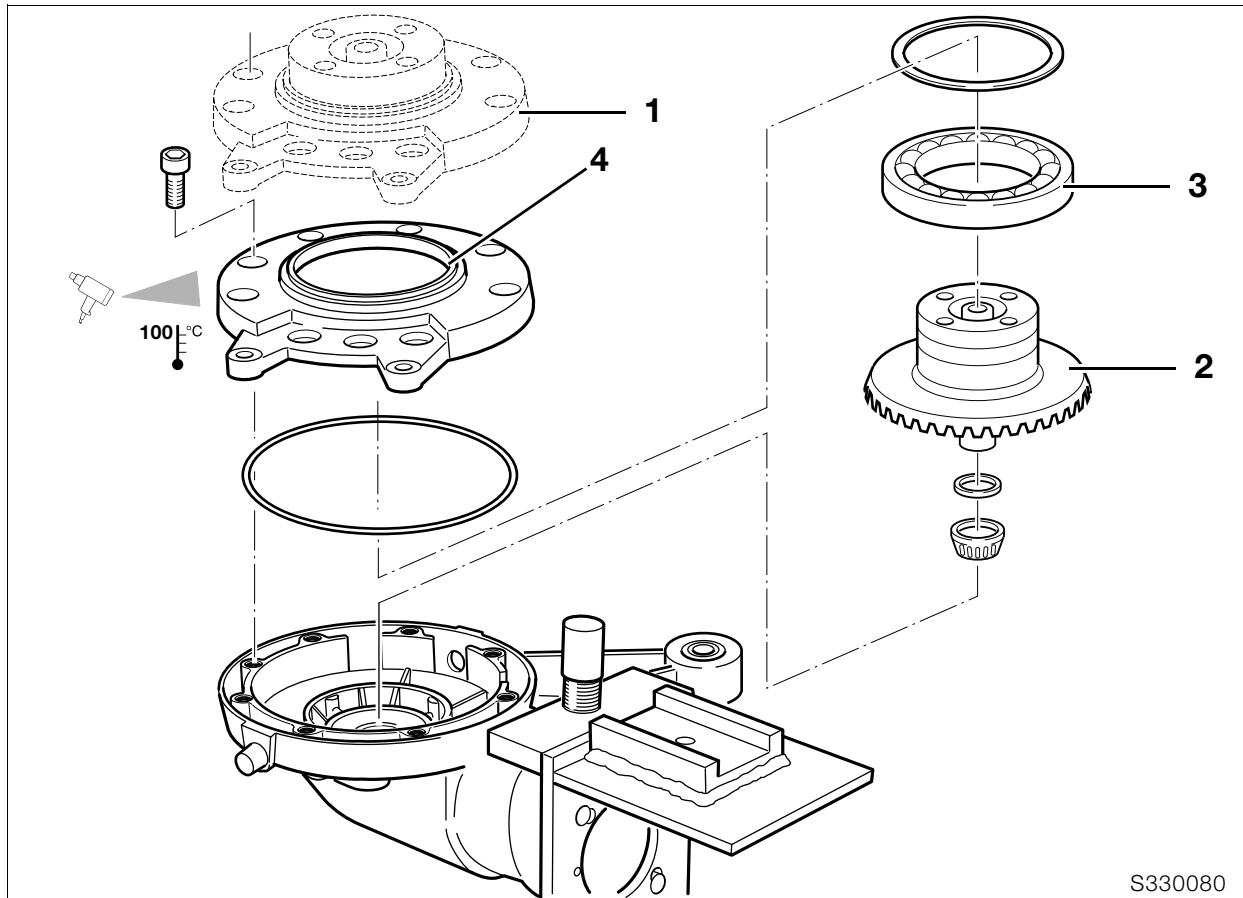

S330080

Removing and disassembling crown wheel

- Remove housing cover (1) with crown wheel (2) and bearing (3).
- Heat housing cover to 100 °C (212°F) and pull it off.
- Force shaft seal (4) out of housing cover with drift.

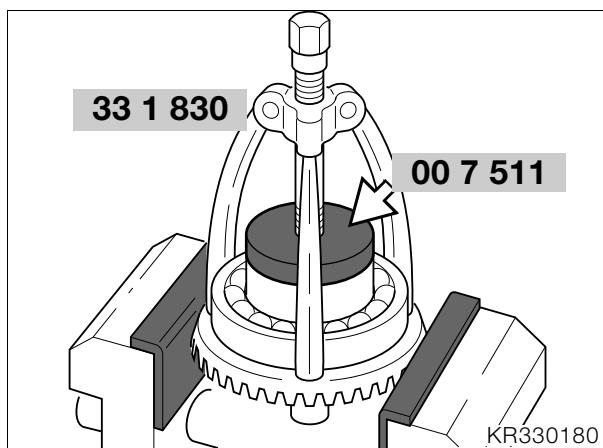

- Clamp crown wheel in vise with protective jaws.
- Insert thrust block (arrow), **BMW No. 00 7 511**.
- Use puller, **BMW No. 33 1 830**, to pull off the grooved ball bearing.

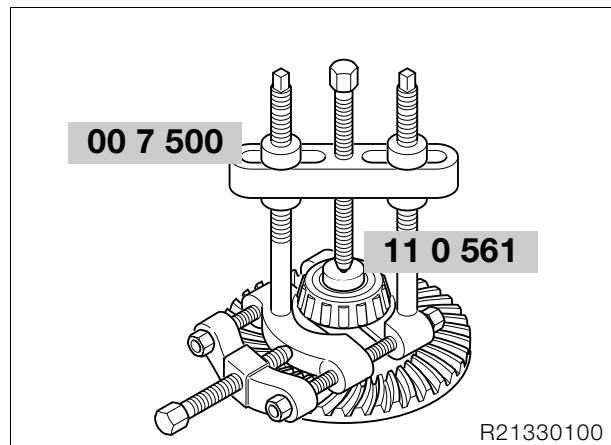

R21330100

- Insert thrust block, **BMW No. 11 0 561**.
- Using puller, **BMW No. 00 7 500**, pull taper roller bearing off crown wheel.
- Turn the housing upside down and heat it until the outer ring is released and drops out (max. 100 °C/212 °F).

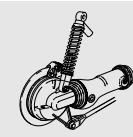

Assembling and installing crown wheel

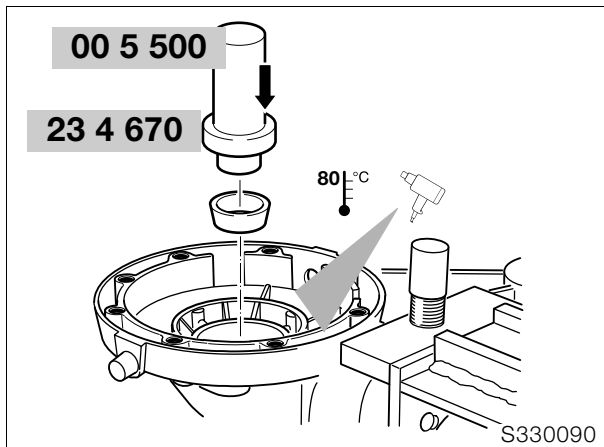

- Heat the housing to 80 °C (176 °F).
- Insert the outer race in the bearing seat with drift, **BMW No. 23 4 670**, and handle, **BMW No. 00 5 500**.
- Check that outer race is correctly seated by tapping gently.



Note:

If new parts are installed (e.g. taper roller bearing), check tooth backlash and adjust if necessary.

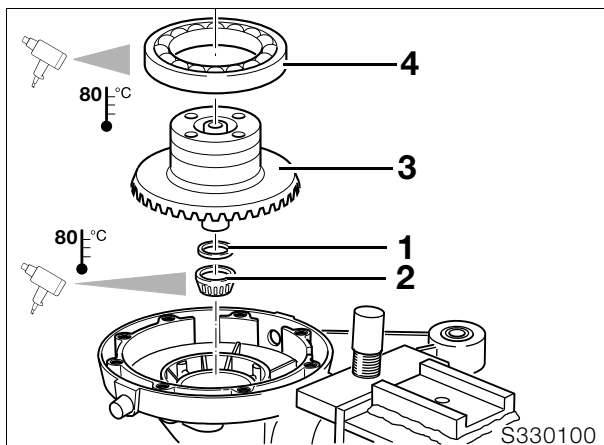

- Place original spacer (1) or spacer measuring 2.25 mm (0.0886 in) in thickness on crown wheel (for provisional backlash).



Note:

Install spacer with bevel on inside diameter toward crown wheel.

- Heat taper roller bearing (2) to 80 °C (176 °F) and push it on.
- Install crown wheel (3).
- Heat grooved ball bearing (4) to 80 °C (176 °F) and place it in position.

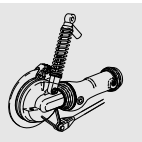

Shimming input bevel pinion and crown wheel

- It is important to shim the input bevel pinion and the crown wheel if the gear set or housing has been replaced.



Note:

The two components of the gear set (input bevel gear and crown wheel) must have matching numbers (1).

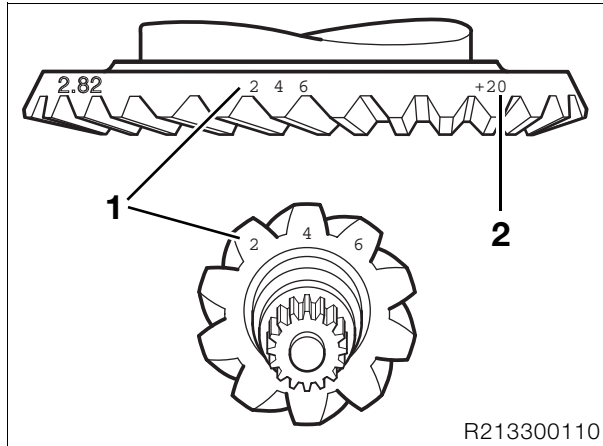

- Measure dimension **K** at the input bevel pinion, taking into account the deviation (2) with sign as stated on the crown wheel from the basic dimension of 77.50 mm (3.0511 in):

$$\text{e.g.: } K = 77.50 \text{ mm} + 0.20 \text{ mm} = 77.70 \text{ mm} \\ (3.0512 \text{ in} + 0.0079 \text{ in} = 3.059 \text{ in})$$

- Measure housing dimension **G**:
- If **G** deviates from the housing basic dimension of 75.50 mm (2.972 in) the two places after the decimal point are stated
- on the housing neck:

$$\text{e.g.: } G = 75.45 \text{ mm} \\ (2.9705 \text{ in})$$

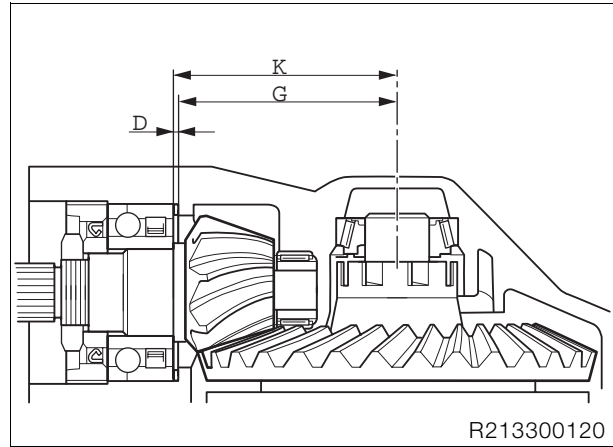

- Calculate required thickness of spacer **D**:

$$D = K - G$$

$$\text{e.g.: } D = 77.70 \text{ mm} - 75.45 \text{ mm} = \mathbf{2.25 \text{ mm}} \\ (3.059 \text{ in} - 2.9705 \text{ in} = 0.0886 \text{ in})$$



Note:

If there is no deviation marked on the crown wheel and no size on the housing the sizes are in compliance with the basic sizes, which means that the required spacer thickness is 2 mm (77.5 mm - 75.5 mm) / 0.0788 in (3.0512 in - 2.9725 in)

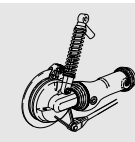

Checking tooth contact pattern

- The tooth contact pattern must be checked if the gear set, housing or input bevel pinion bearing have been replaced.



Note:

Before checking the contact pattern, make sure that tooth backlash (provisional, if necessary) is correct.

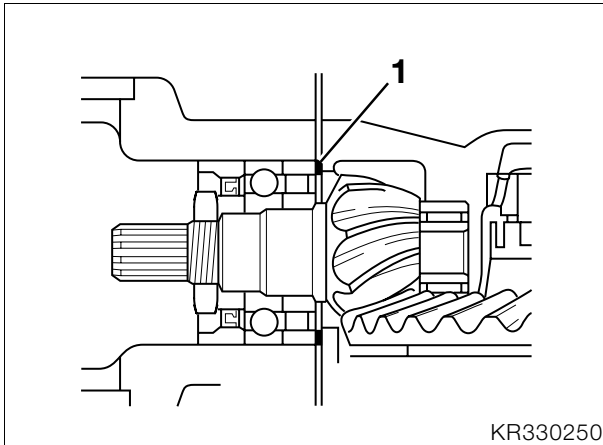

Note:

The contact pattern is adjusted by means of the shim washer (1) on the input bevel pinion.

- Clean and degrease tooth flanks of crown wheel and bevel gear.
- Coat three tooth flanks of the crown wheel with **marking ink**.
- Install measuring fixture, **BMW No. 33 2 600**, centre crown wheel and use the balls of your hands to press it into the housing and turn it back and forth a few times.

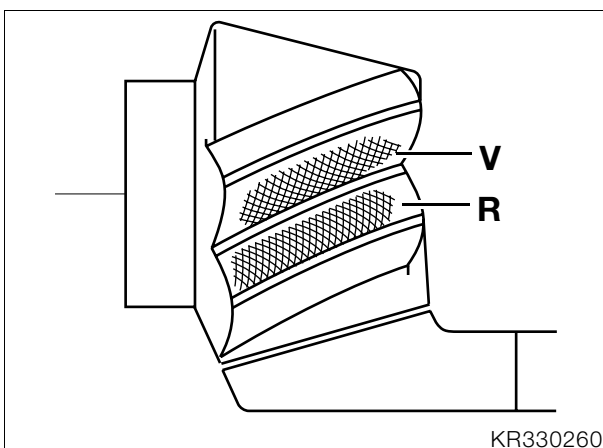

- If the correct shim is installed, the following contact pattern appears with no load applied.



Note:

The contact pattern is centered on leading flank "V". The contact pattern is closer to the larger diameter on trailing flank "R".



Caution:

Make sure that teeth are not in contact at the smaller diameter.

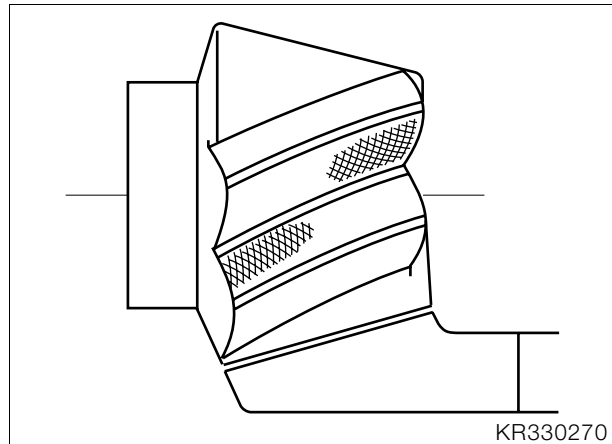

- Install a thinner shim if the contact pattern looks like this.

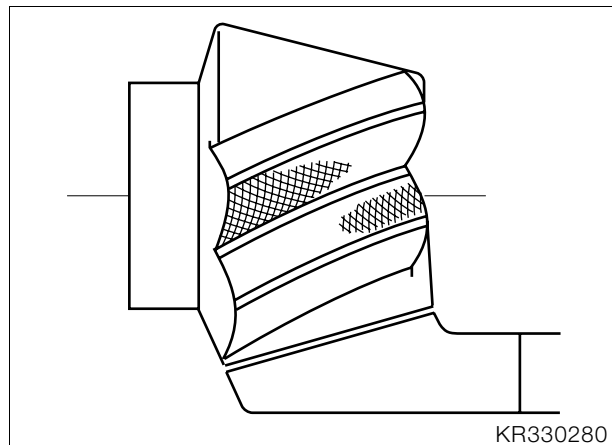

- Install a thicker shim if the contact pattern looks like this.
- Clean the tooth flanks.

Checking and adjusting backlash

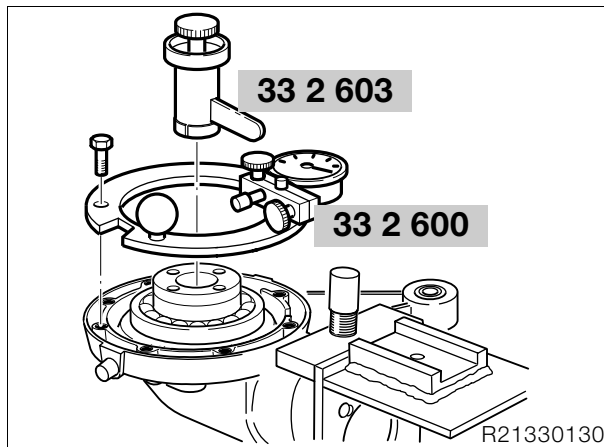

- Secure measuring device, **BMW No. 33 2 600**, with dial gauge to crown wheel and secure to housing with the knurled screw.
- Secure measuring arm, **BMW No. 33 2 603**, centrally to crown wheel.

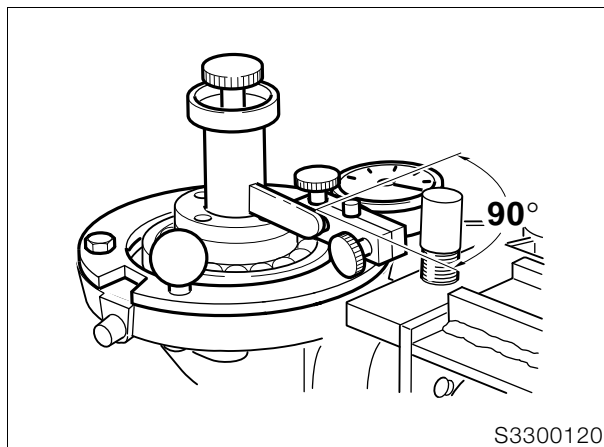

- Using the balls of your hands, press the crown wheel into the housing and turn it to and fro to check tooth backlash.



Note:

Check tooth backlash at three points 120 degrees apart; turn the bevel pinion with the crown wheel.

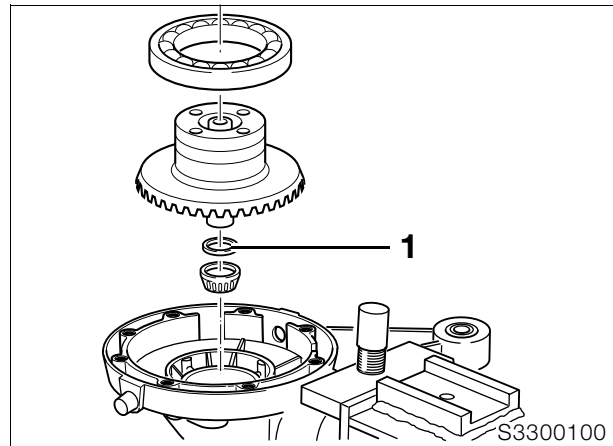

- Compensate for excessive backlash by inserting a thinner shim washer, and for insufficient backlash by inserting a thicker shim washer (1).



Note:

Install spacer with bevel on inside diameter toward crown wheel.

Backlash:

(adjust without oil
 0.07...0.16 mm (0.0027 ... 0.0063 in)
 provisional backlash.....
 0.1...0.5 mm (0.0039 ... 0.0197 in)

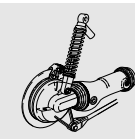

Shimming housing cover

- In order to obtain the correct taper roller bearing preload, the housing cover must be correctly shimmed.

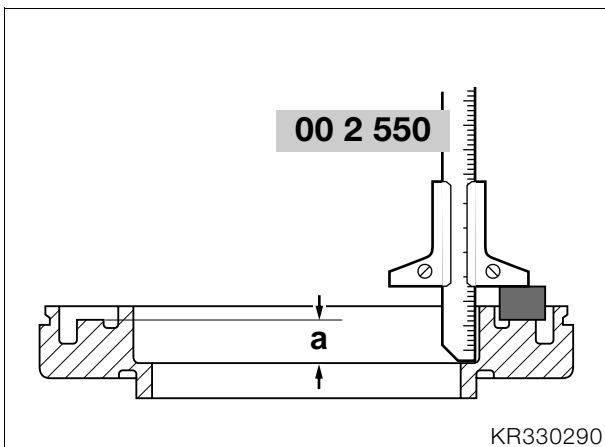

- Using depth gauge, **BMW No. 00 2 550**, measure distance "a".

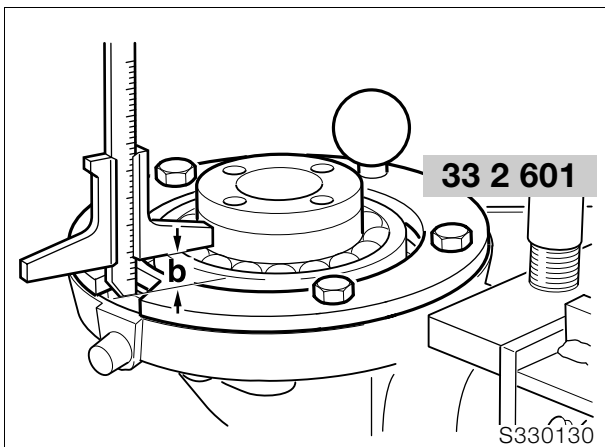

- Place measuring ring, **BMW No. 33 2 601**, in position and secure it.
- Measure from the outer ball bearing race through the cutout in the measuring ring to the housing mating face and calculate distance "b".
- Distance "a" – distance "b" = shim thickness (without preload).
- Apply a light coat of grease to the selected shim washer, and install it.

Preload:..... 0.05...0.1 mm (0.0020 ... 0.0039 in)

Installing housing cover

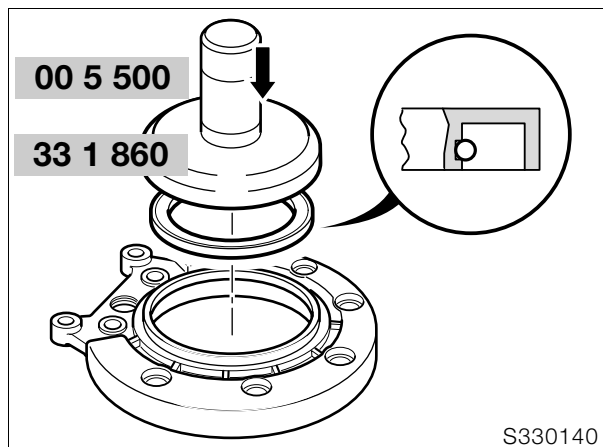

- Lightly oil the lip and outer edge of the sealing ring.
- Using drift, **BMW No. 33 1 860**, and handle, **BMW No. 00 5 500**, drive in the sealing ring.
- Heat housing cover to 80 °C (176 °F) and install.
- Tighten securing screws in diagonally opposite sequence.

Tightening torque:

Housing cover..... 35 Nm

Installing sliding element

- Coat splines on input pinion with **Staburags NBU 30 PTM**.
- Fit sliding element to drive pinion.
- Locate retaining ring with gentle blows (plastic hammer).

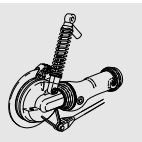

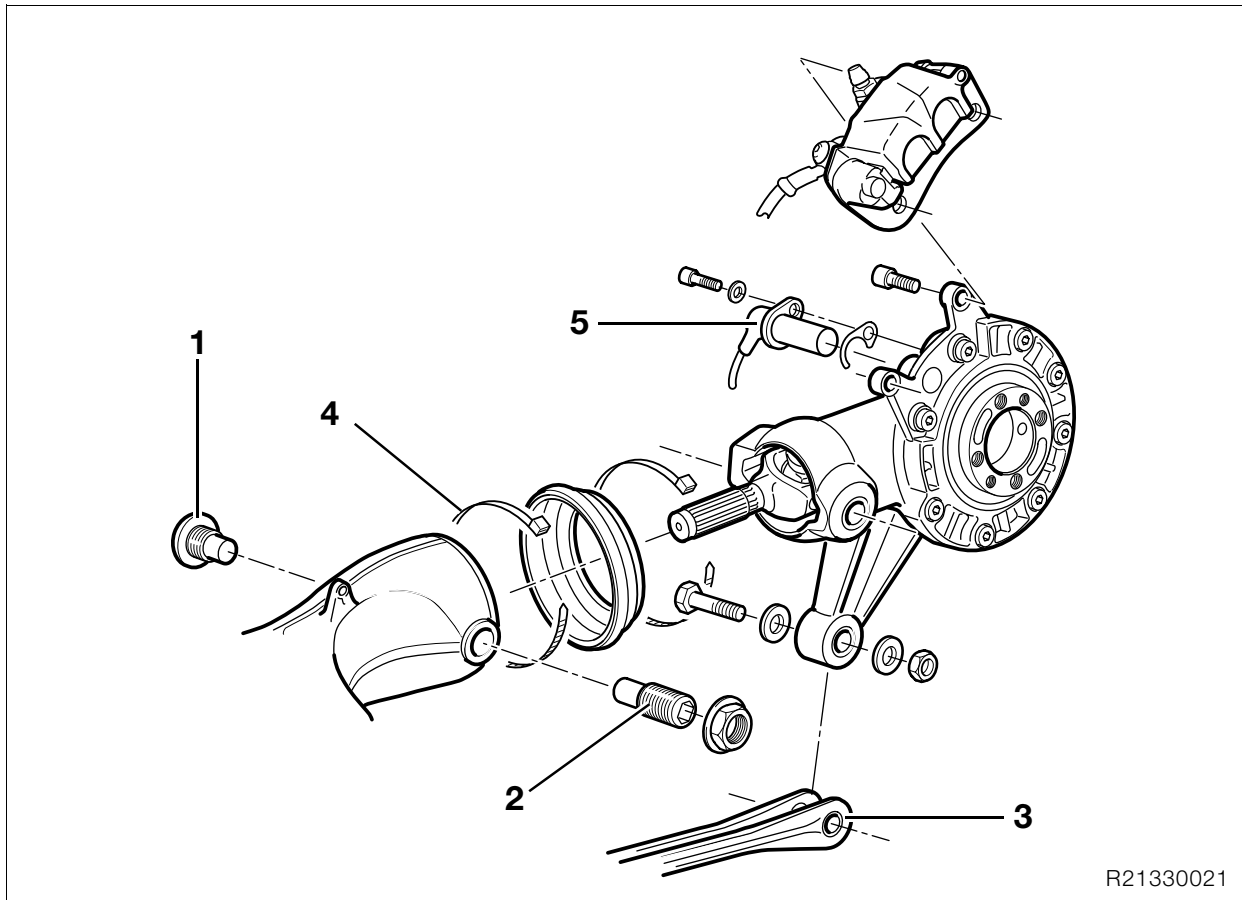

Installing rear wheel drive



Note:

Do not lay oil-filled rear-wheel drive on its side prior to installation, as this will cause oil to escape when the motorcycle is on the road (suction effect).

- Coat splines of sliding element (arrow) with **Staburags NBU 30 PTM**.
- Install the inner races of the needle roller bearings with a small quantity of **Staburags NBU 30 PTM**.
- Place rear-wheel drive with flexible gaiter in position and introduce sliding element into universal shaft.



Caution:

The universal joints for universal shaft and rear wheel drive must be installed in the same direction. Support the rear wheel drive.

- Install fixed-bearing stud bolt (1) with **Loctite**.



Caution:

Make sure that the inner race never presses against the ends of the needles.

- Install floating-bearing stud bolt (2) with **Loctite**.
- Tighten fixed bearing stud bolt.
- Tighten floating bearing stud bolt.
- Firmly tighten locknut.

- Load approx. 85 kg (187 lbs) onto motorcycle and tighten loose reaction link (3).
- Tighten clamping strap (4) on gaiter.



Caution:

When tightening threaded fasteners coated with Loctite 2701, always apply final torque without delay.

Allow at least 3 hours for the Loctite to cure.



Note:

Use an acetone-based cleaning agent such as Loctite quick cleaner 706
Loctite Order No. 70636-AC



Tightening torque:

Fixed bearing stud bolt (thread cleaned + Loctite 2701).....	160 Nm
Floating-bearing stud bolt (clean thread + Loctite 2701).....	7 Nm
Locknut.....	160 Nm
Reaction link to rear wheel drive	43 Nm

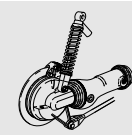

- If necessary, fill with oil.

Quantity:

Initial filling/oil changes.....
approx. 0.25 l (0.44 Imp. pint/0.26 US quart)
 Oil grade:
 Brand-name hypoid gear oil, SAE 90, API class GL 5

- Install the rear wheel.
- Install brake caliper.

Caution:

Do not damage brake pads; keep the brake caliper parallel to the brake disc when installing.

- [ABS] Install sensor (5).
- [ABS] Check that sensor gap is correct.

ABS rear sensor gap:
 0.45...0.55 mm (0.018 ... 0.022 in)

- Install rear wheel cover.

Tightening torque:

Rear wheel cover to rear wheel drive
 M 5 (clean thread + Loctite 638)..... 5 Nm

Removing and installing spring strut



Note:

To remove the spring strut, support the rear axle.

- Remove the seat.
- Remove height adjuster from seat on right.
- Remove rear wheel.

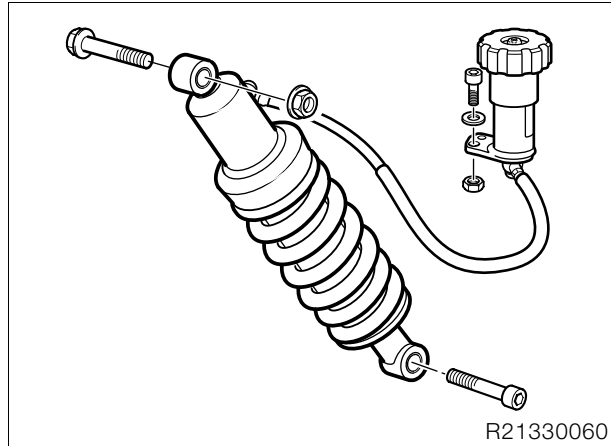

- Remove hydraulic spring adjuster.
- Remove spring strut.
- Installation is the reverse of the removal procedure.

Tightening torque:

Spring strut to rear frame 50 Nm
 Spring strut to swinging arm
 (clean thread + Loctite 243)..... 58 Nm
 Hydraulic spring preload adjuster
 to footrest plate 22 Nm

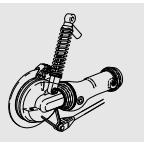

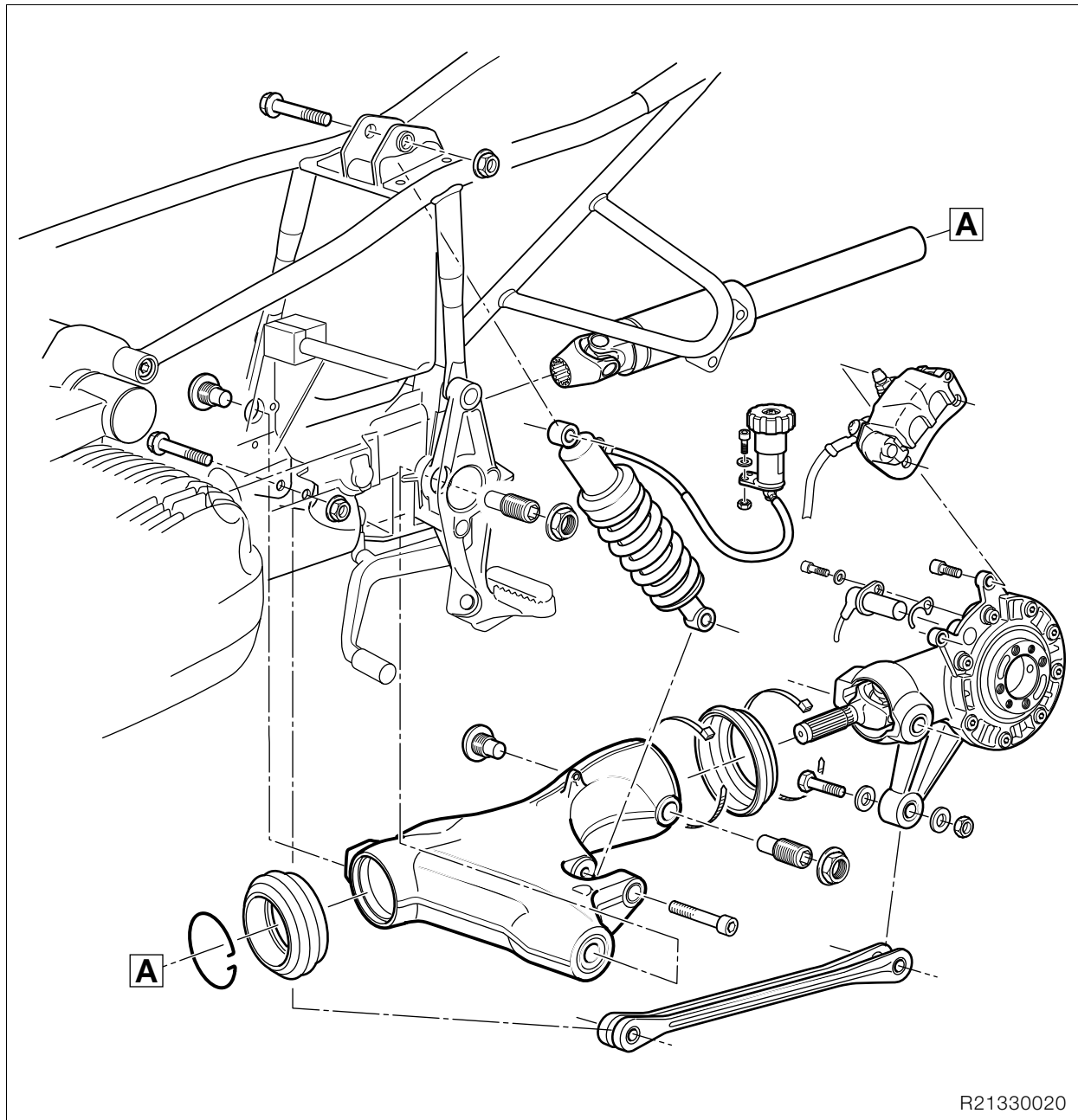

R21330020

Removing and installing rear swinging arm

Removing rear swinging arm

- Remove rear wheel drive unit.
- Remove rear spring strut.
- Swinging-arm bearing studs are secured with Loctite: heat to max. 120 °C (248 °F) to release.
- Loosen floating bearing stud bolt.
- Loosen fixed bearing stud bolt.
- Remove floating bearing/ fixed bearing stud bolts.
- Remove swinging arm with gaiter.

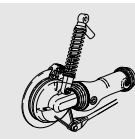

Removing and installing taper roller bearing

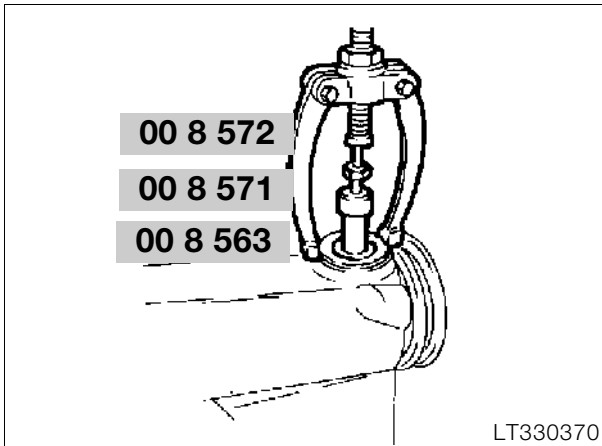

- Remove taper roller bearing with counter-support, **BMW No. 00 8 572**, and internal puller 21/2, **BMW No. 00 8 571**, with ring support.
- Pull out outer race with internal puller 21/5, **BMW No. 00 8 563**.
- To install the bearing, heat the swinging arm to 80 °C (176 °F).
- Drive in bearing with drift, **BMW No. 33 5 700**.

Removing and installing flexible gaiter

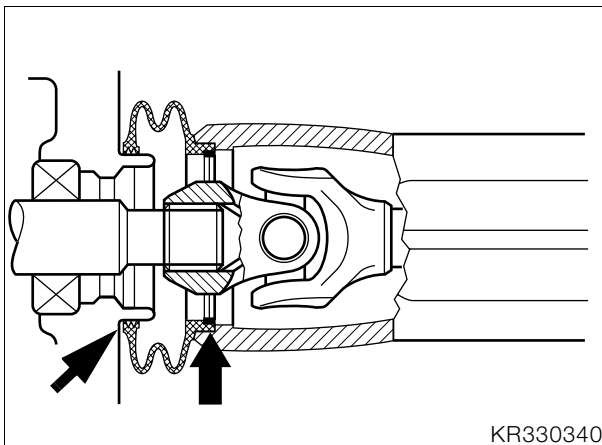

- Pull flexible gaiter with circlip out of swinging arm.
- When installing, coat inner and outer sealing lips (arrows) with **Staburags NBU 30 PTM**.

Caution:

Drive shaft clearance when suspension is compressed: gap of retaining ring must be in the horizontal plane.

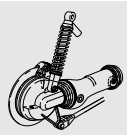

Removing drive shaft

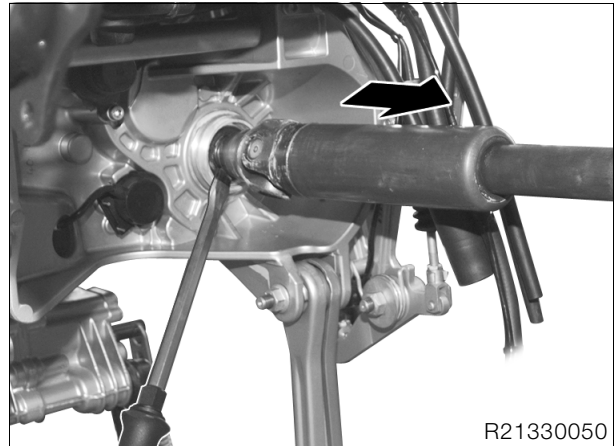

- Press off drive shaft.

Caution:

Avoid scratching painted parts; use an underlay if necessary.

Checking universal joint for wear

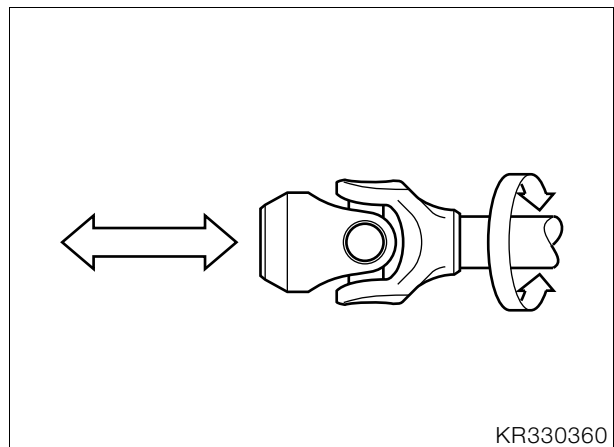

- Measure axial and radial play.

Installing drive shaft

- Coat the splines on the output shaft with **Staburags NBU 30 PTM**.
- Fit drive shaft to output shaft.
- Engage the snap ring with gentle blows (plastic hammer).

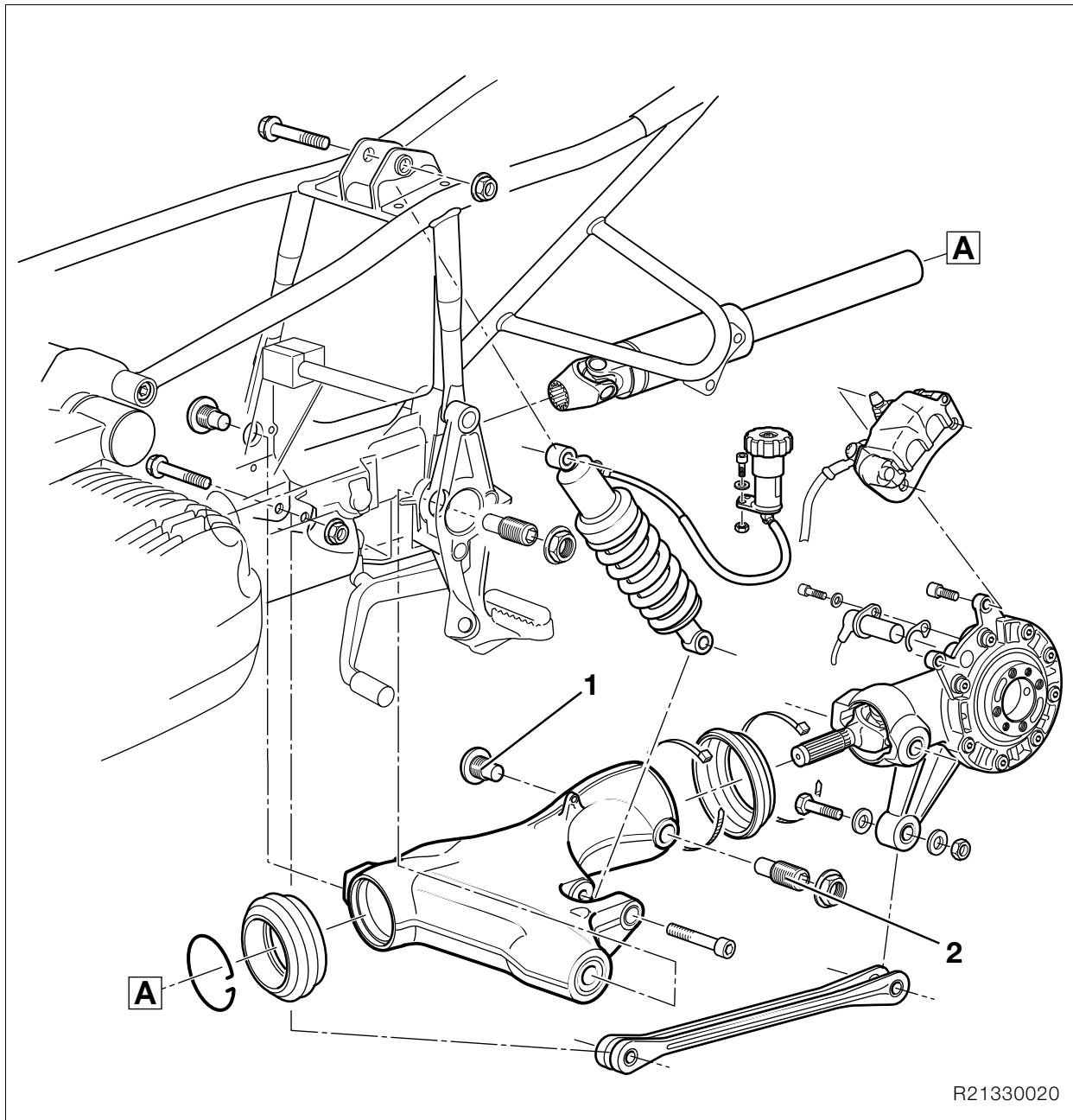

Installing rear swinging arm

- Slide swinging arm over drive shaft as far as possible until rubber gaiter connects on housing neck.
- Install fixed-bearing stud bolt (1) with **Loctite**.
- Install floating-bearing stud bolt (2) with **Loctite**.
- Tighten fixed bearing stud bolt.
- Tighten floating bearing stud bolt.
- Firmly tighten locknut.
- Secure spring strut.

Caution:

The universal joints for universal shaft and rear wheel drive must be installed in the same position.

Caution:

When tightening threaded fasteners coated with Loctite 2701, always apply final torque without delay. Allow at least 3 hours for the Loctite to cure.

Tightening torque:

Fixed-bearing stud bolt (clean thread + Loctite 2701).....	160 Nm
Floating-bearing stud bolt (clean thread + Loctite 2701).....	7 Nm
Locknut.....	160 Nm
Spring strut to swinging arm (clean thread + Loctite 243).....	58 Nm
Spring strut to rear frame	50 Nm

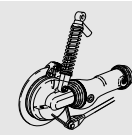

34 Brakes

Contents

Page

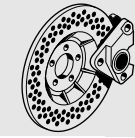

Technical Data	3
Removing and installing front brake caliper	4
Disassembling and assembling front brake caliper	5
Removing and installing filler adapter	6
Removing and installing rear brake caliper	7
Disassembling and assembling rear brake caliper	8
Removing and installing front brake disc	9
Removing and installing rear brake disc (mounted on rear-wheel hub)	10
Removing and installing front ABS sensor	11
ABS sensor gap, front: adjusting	12
Marking sensor ring	12
Checking and adjusting sensor gap	12
Removing and installing rear ABS sensor	13
Adjusting rear ABS sensor gap	14
Marking sensor wheel	14
Checking and adjusting sensor gap	14
Removing and installing rear brake master cylinder	15
Checking and adjusting play of piston rod	16
Removing and installing footbrake lever	16
Removing and installing ABS unit	17
Removing the ABS unit	17
Installing the ABS unit	18
Removing and installing ABS relay and relay socket	18
Removing ABS relay	18
Installing the ABS relay	19

Contents

Page

Removing ABS relay socket	19
Installing the ABS relay base	20
Removing and installing brake line (with ABS)	21
Removing and installing front brake line	21
Removing and installing rear brake line	22

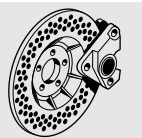

Technical Data		R 1150 GS
Brake fluid		DOT 4
Minimum lining thickness, front	mm (in)	1.0 (0.04)
Minimum lining thickness, rear		If the brake disc is visible through the bore in the wheel-side brake pad, the brake lining is worn to its minimum permissible thickness.
Front wheel		
Brake disc dia.	mm (in)	305 (12.0)
Brake disc thickness	mm (in)	5.0 (0.20)
Minimum thickness	mm (in)	4.5 (0.18)
Brake pad surface area	cm ² (sq in)	100 (15.5)
Piston dia. in brake caliper	mm (in)	32/34 (1.26/1.34)
Piston diameter in handlebar lever cylinder	mm (in)	16 (0.6)
Sensor gap, front	mm (in)	0.45 ... 0.55 (0.018 ... 0.022)
Brake pad lining		Sintered metal
Rear wheel		
Brake disc dia.	mm (in)	276 (10.87)
Brake disc thickness	mm (in)	5.0 (0.20)
Minimum thickness	mm (in)	4.5 (0.18)
Brake pad surface area	cm ² (sq in)	34 (5.27)
Piston dia. in brake caliper	mm (in)	26/28 (1.02/1.10) with insulating piston
Piston dia. in foot brake cylinder	mm (in)	13 (0.5)
Sensor gap, rear	mm (in)	0.45...0.55 (0.018 ... 0.022)
Brake pad lining		Semi-metallic

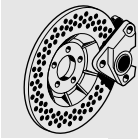

Removing and installing front brake caliper

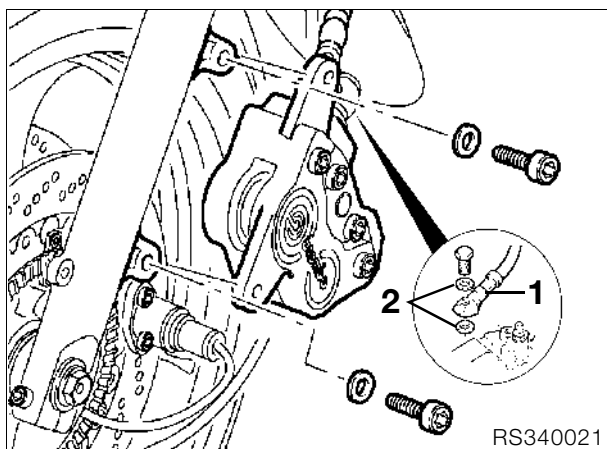
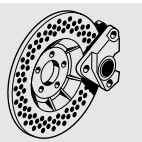

RS340021



Caution:

Do not allow brake fluid to come into contact with painted parts of the motorcycle as brake fluid destroys paint.

- Drain the brake system.
- Disconnect brake line (1).
- Remove screws securing the brake caliper.

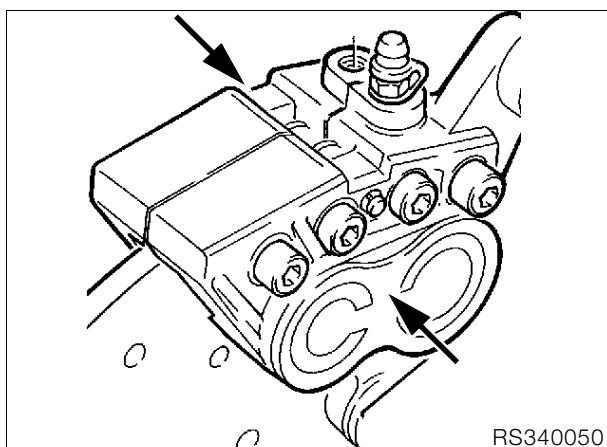

RS340050

- Force back the brake pads and pistons (arrows).



Caution:

Do not damage brake pads.

- Carefully remove the brake caliper.
- Installation is the reverse of the removal procedure.
- Force back the brake pads and pistons.
- Fill and bleed the brake system.

→ see Group 00



Caution:

Replace the sealing rings (2) in the brake line.
Do not damage brake pads.



Tightening torque:

Brake caliper to fork slider tube..... 40 Nm
Brake hose to brake caliper 18 Nm
Bleed screw to brake caliper 14 Nm

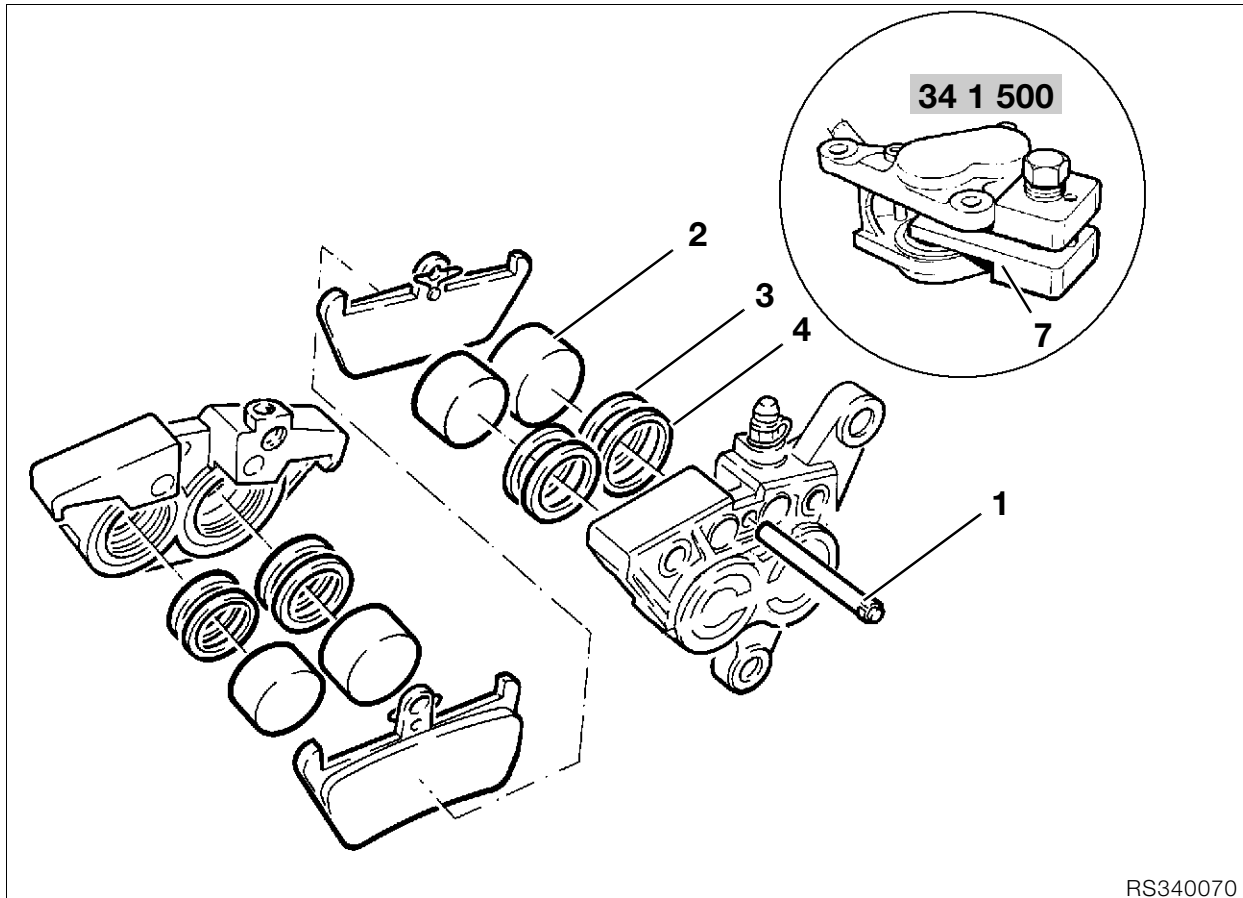

RS340070

Disassembling and assembling front brake caliper



Caution:

Do **not separate** the brake caliper halves!

- Remove the brake caliper.
- Remove keeper from retaining pin (1).
- Drive out the retaining pin (1) from the wheel side.
- Remove brake pads by pulling downwards.
- Close the bleed screw.



Tightening torque:

Bleed screw in brake caliper 14 Nm

- Secure two opposing brake pistons with resetting tool, **BMW No. 34 1 500**.
- Place a cloth between the other pair of pistons.



Caution:

Do not insert your fingers between the pistons; risk of injury

- **Carefully** press out brake pistons (2), using a compressed air gun at the brake line connection.
- Remove the two sealing rings (3,4) from the left and right brake cylinder bores.
- Inspect the brake caliper piston for hairline cracks, score-marks and other damage.

- Coat new sealing rings (3,4) with brake fluid and install.



Caution:

Keep the brake pistons parallel with their bores when installing.

- Coat brake caliper pistons (2) with brake fluid and insert.
- Remove and install the other two brake pistons in the same way.
- Using piston compressor (7), **BMW No. 34 1 500**, if necessary press the pistons fully back.
- Install the brake pads.

Removing and installing filler adapter

- Remove right-hand brake caliper.
- Remove the brake pads.

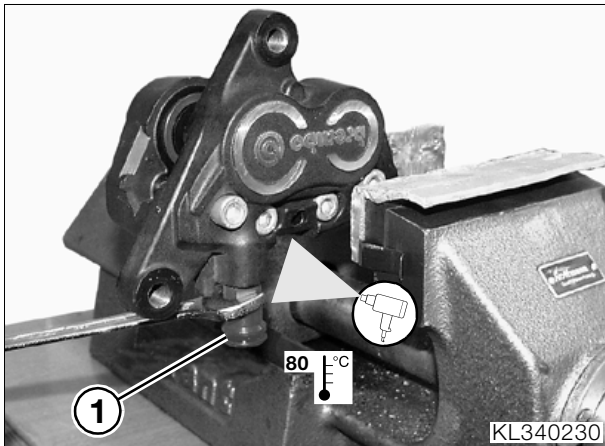

- Secure the brake caliper in a vise. Filler adapter (1) must face down, so that no traces of thread-locking compound can make their way into the brake caliper when the filler adapter is released.

Caution:

Do not allow traces of adhesive to make their way into the brake caliper.

- Heat filler adapter (1) to approx. 80° C (176 °F) and use an open-ended wrench to remove.

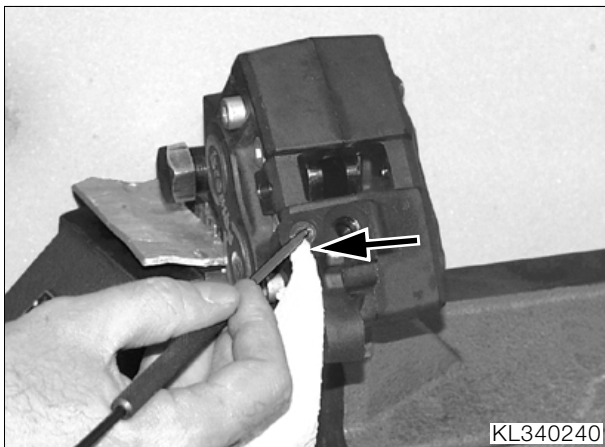

- Seal the bore in the brake caliper with a paper towel or similar (arrow).
- Clean the threads, using a scribe or similar to detach the remains of the adhesive and blow out with a low-pressure jet of air.

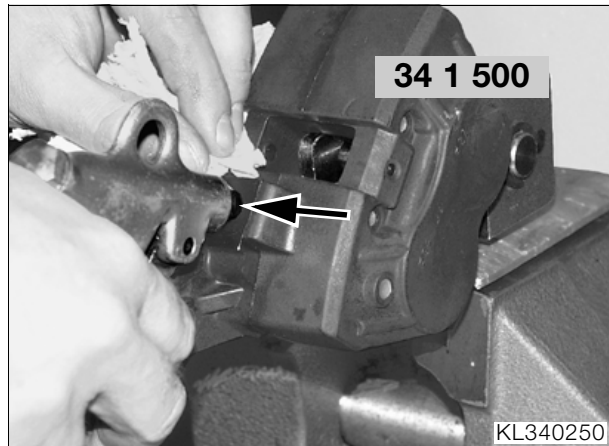

- Secure brake pistons with resetting tool, **BMW No. 34 1 500**.
- Inject compressed air through the connecting bore (arrow) in the brake caliper to blow out traces of thread-locking compound that might have made their way into the brake caliper.
- Remove brake fluid from the threads.
- Install the filler adapter or bleed screw.
- Further installation is the reverse of the removal procedure.

Tightening torques:

Filler adapter in brake caliper	18 Nm
(clean thread + Loctite 243 or install bleed screw)	
Brake hose to brake caliper	18 Nm
Brake caliper to fork slider tube.....	40 Nm
Grub screw in filler adapter	10 Nm
Bleed screw	14 Nm
Bleed screw in filler adapter	14 Nm

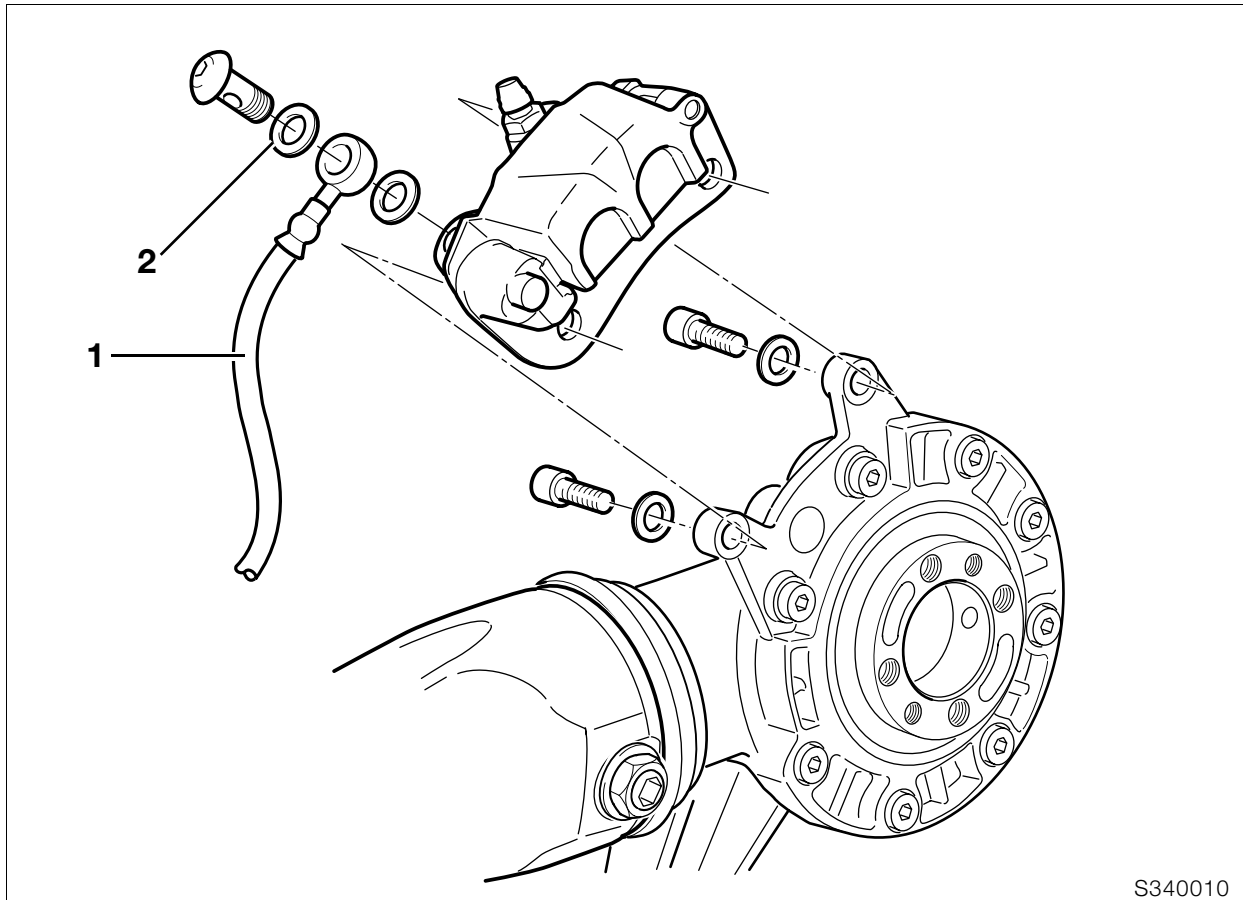

S340010

Removing and installing rear brake caliper

Sensor gap:..... 0.45...0.55 mm (0.018 ... 0.022 in)

Caution:

Do not allow brake fluid to come into contact with painted parts of the motorcycle as brake fluid destroys paint.

- Drain the brake system.
- Disconnect brake line (1) from brake caliper.
- Remove screws securing the brake caliper.
- Installation is the reverse of the removal procedure.
- Force back the brake pads and pistons.
- Fill and bleed the brake system.

Caution:

Replace the sealing rings (2) in the brake line. Do not damage brake pads.

[ABS] Check sensor gap and adjust if necessary with shim.

Tightening torque:

Brake caliper to rear wheel drive 40 Nm
 Brake line to brake caliper 18 Nm
 Bleed screw in brake caliper 6 Nm

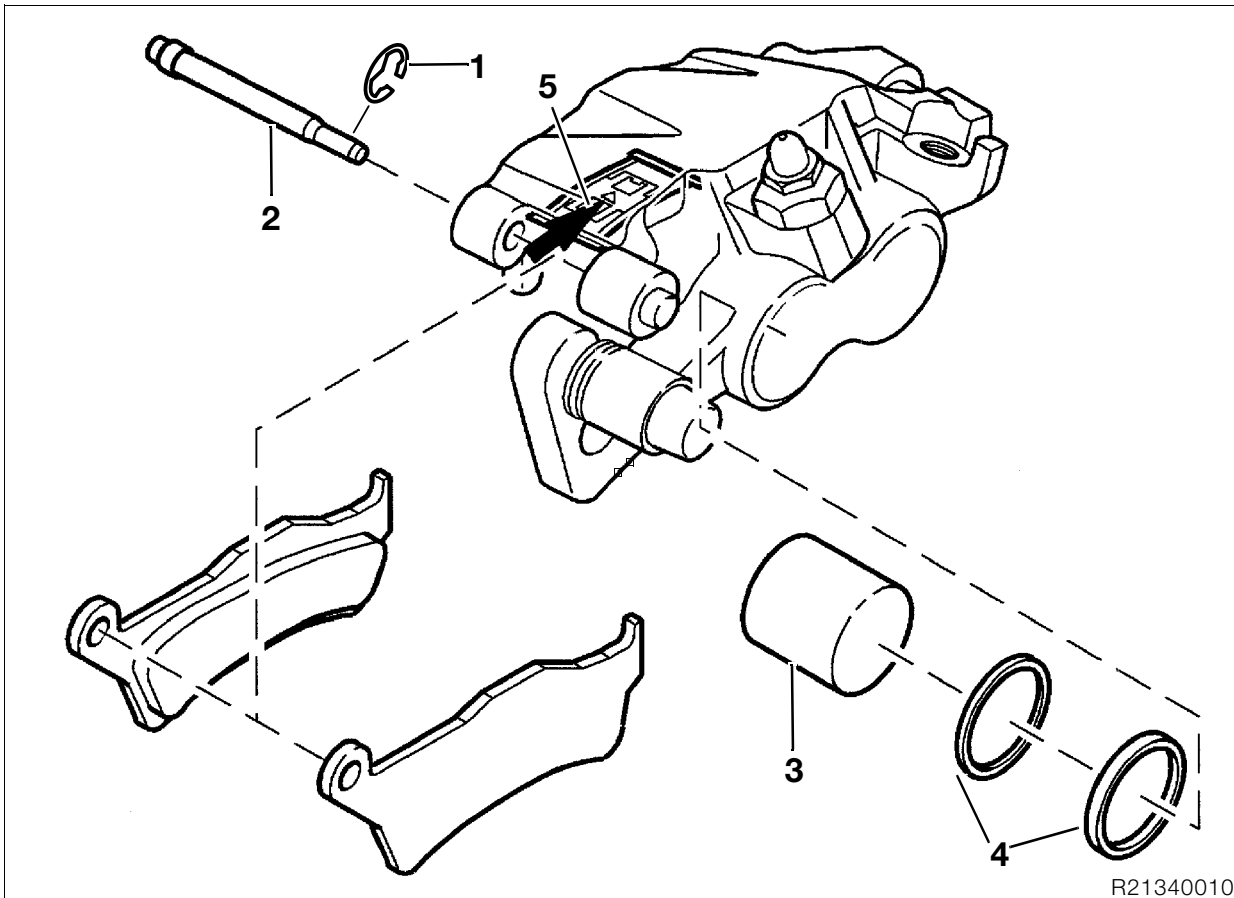
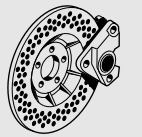

R21340010

Disassembling and assembling rear brake caliper

- Remove retaining washer (1).
- Drive the retaining pin (2) out towards the wheel side.
- Remove brake pads.
- Close the bleed screw.



Tightening torque:

Bleed screw in brake caliper 6 Nm

- Hold a cloth over the brake caliper piston.
- **Carefully** press out brake piston (3) with a compressed air gun applied to the connecting bore; work at low air pressure.



Caution:

Keep fingers away from gap between piston and side contact face of brake pads; risk of injury.

- Remove sealing rings (4) from left and right bores.
- Inspect the brake caliper piston for hairline cracks, score-marks and other damage.
- Coat the new sealing rings with brake fluid and insert them into the left and right brake caliper bores.



Caution:

Keep the brake pistons parallel with their bores when installing.

- Coat both brake caliper pistons with brake fluid and install them.
- Coat the adapter plate locating pins with **Shell Retinax A** and install the adapter plate.
- Insert locating plate (5) into brake caliper.



Note:

The installed position must be correct (arrow pointing in forward-travel direction).

- Insert brake pads and secure with retainers.

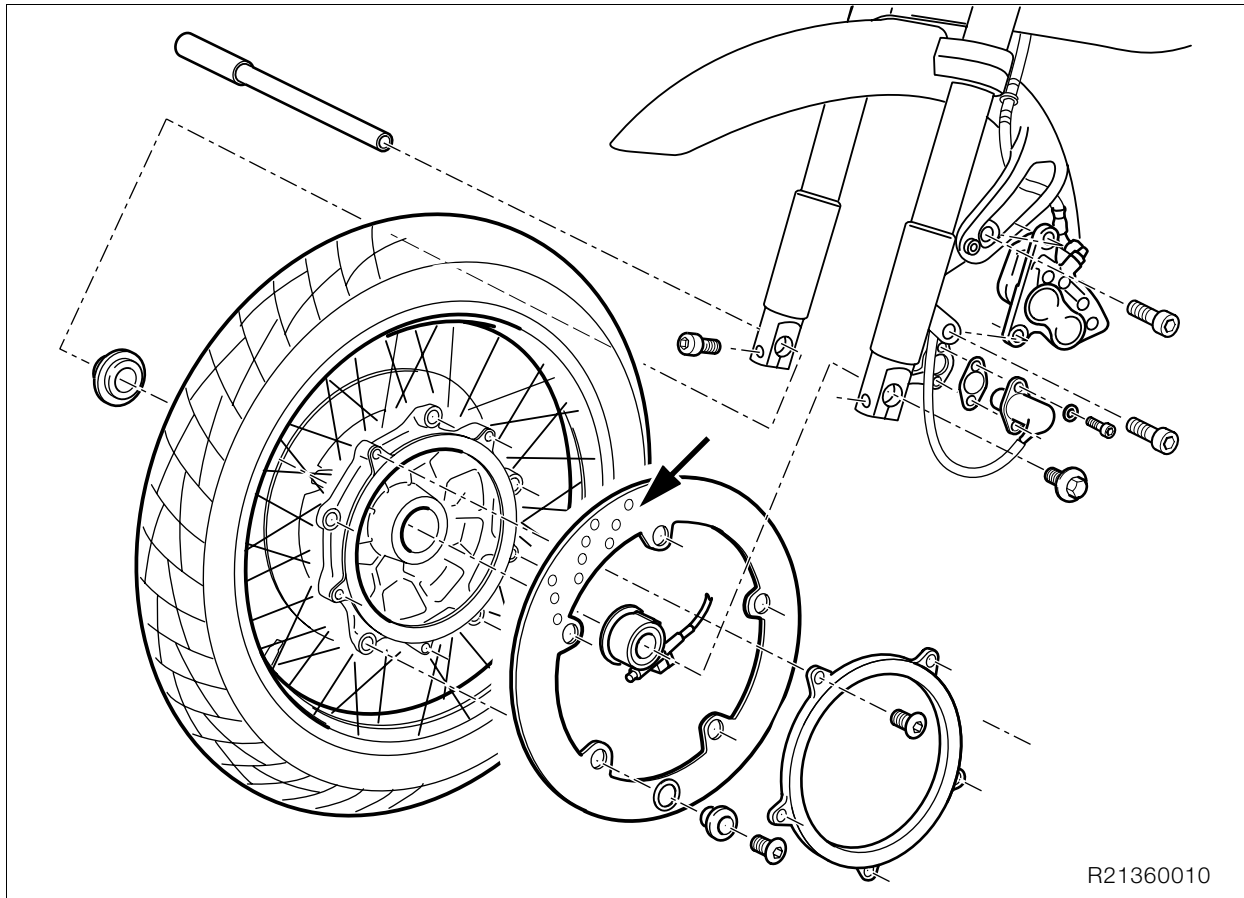

Removing and installing front brake disc

- Remove screws securing the brake caliper.
- Remove front wheel.
- Remove and install brake discs.
- Degrease brake discs before installing.



Note:

Installed direction (arrow) of brake discs must be correct.



Tightening torque:

Brake disc to front wheel
(clean thread + Loctite 243)..... 24 Nm



Caution:

Check and, if necessary, adjust sensor gap, if components have been replaced apply mark to indicate point where gap is largest.

Sensor gap:..... 0.45...0.55 mm (0.018 ... 0.022 in)

Removing and installing rear brake disc (mounted on rear-wheel hub)

- Remove screws securing the brake caliper.
- Remove rear wheel.

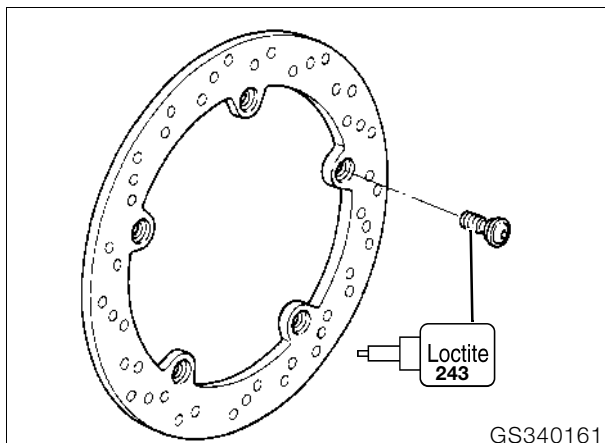
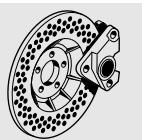

- Remove brake disc.
- Installation is the reverse of the removal procedure.
- Degrease the brake disc before installing.

Caution:

[ABS] Check sensor gap and adjust with shims if necessary.

Sensor gap:.....0.45...0.55 mm
..... (0.018 ... 0.022 in)



Tightening torque:

Brake disc to rear wheel drive
(clean thread + Loctite 243)..... 21 Nm

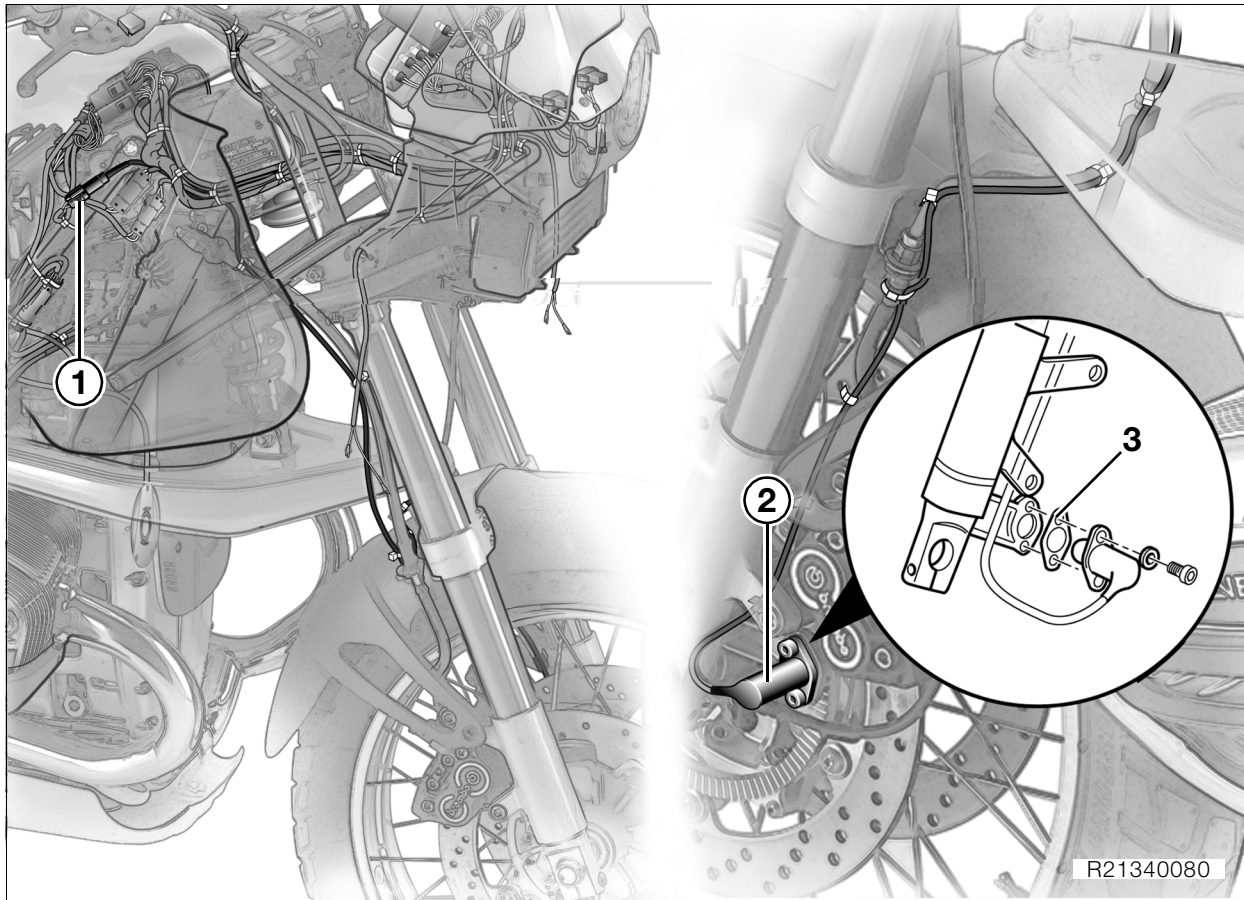

Removing and installing front ABS sensor

- Remove front wheel.
- Remove fuel tank.
- Disconnect plug (1) of sensor cable.
- Remove sensor (2) with **Torx T 25**.
- Installation is the reverse of the removal procedure.



Caution:

Route the sensor cable correctly.
Check sensor gap and adjust if necessary with shim (3).

Sensor gap:..... 0.45...0.55 mm (0.018 ... 0.022 in)



Tightening torque:

Sensorhandtight, 4 Nm

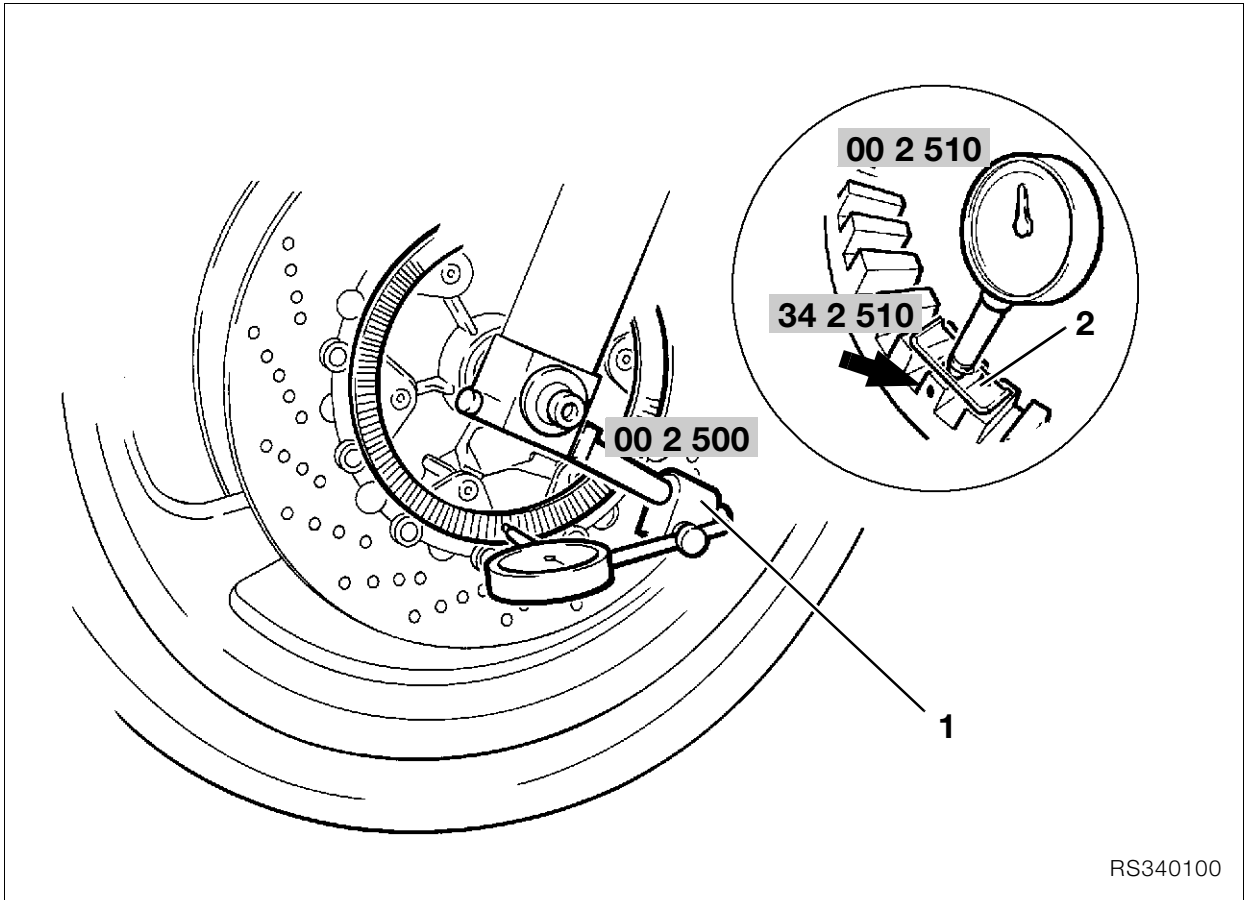

RS340100

ABS sensor gap, front: adjusting

Marking sensor ring

- Take load off front wheel/lift clear of ground.
- Undo clamp screw at left fork tube.
- Attach dial gauge holder (1), **BMW No. 00 2 500**, with dial gauge, **BMW No. 00 2 510**, and measuring shoe (2), **BMW No. 34 2 510**, to fork slider tube.
- Zero the dial gauge.
- Measure axial runout right round the sensor ring.
- Using a touch-up marker, indelibly mark the point where the sensor is farthest away from the sensor ring (arrow).

⚠ Caution:

If parts are replaced (brake disc etc.) and a used (and therefore marked) sensor ring is installed, the sensor ring must be measured and marked again. Remove the old mark.

- Retighten clamp screw of left fork tube.
- Check/adjust ABS sensor gap.

🔧 Tightening torque:

Clamp screw, quick-release axle..... 22 Nm

Checking and adjusting sensor gap

- Check/adjust at the marked point with ABS feeler gauge.
- If necessary, remove/install sensor with **Torx T 25** and adjust sensor gap with shims.

Sensor gap:..... 0.45...0.55 mm (0.018 ... 0.022 in)

⚠ Caution:

After adjusting, rotate the wheel and check that the sensor is clear at all points.

🔧 Tightening torque:

ABS sensor mount.....handtight, 4 Nm

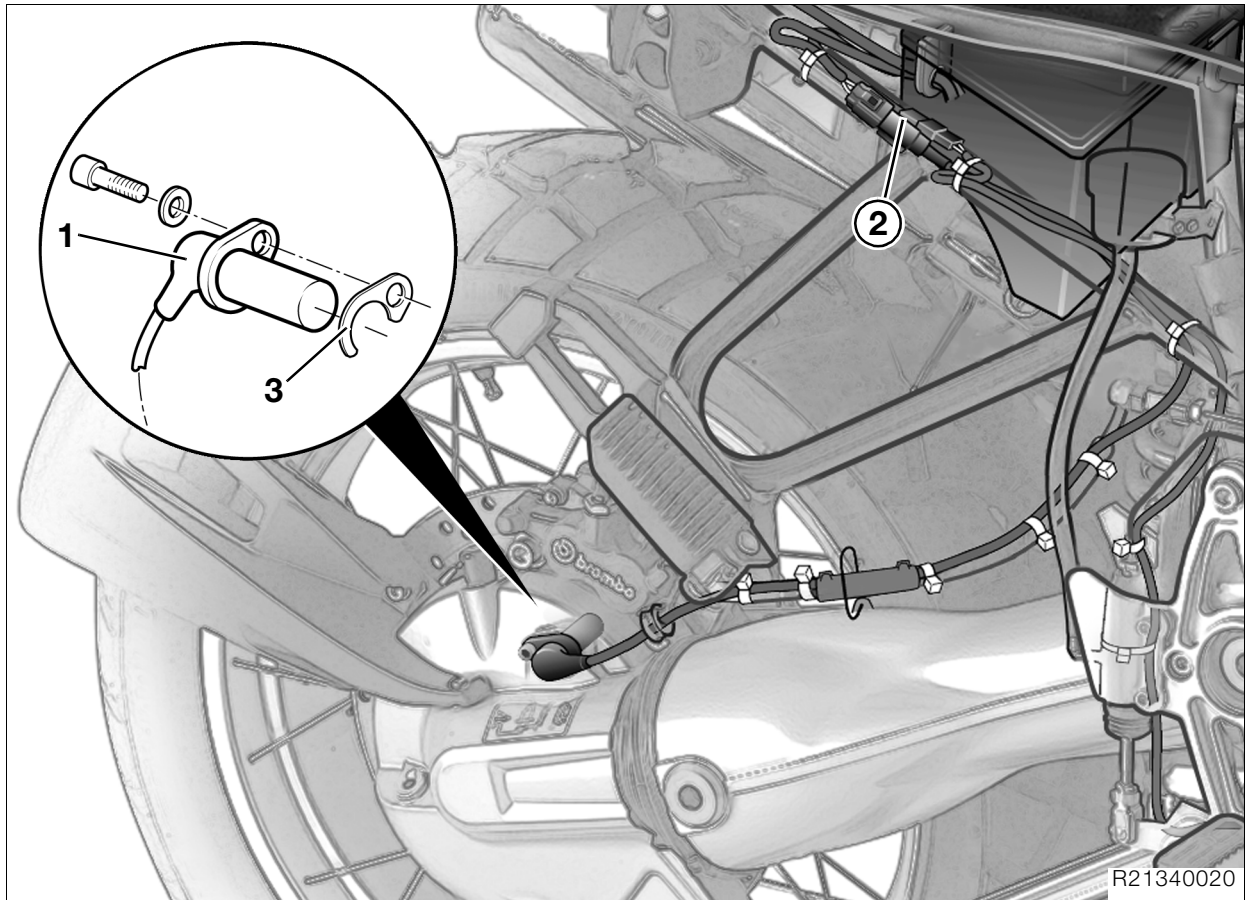

Removing and installing rear ABS sensor

- Before removing/installing, clean the sensor bore.
- Using **Torx T 25**, slacken sensor (1).
- Disconnect plug (2) of sensor cable.
- Installation is the reverse of the removal procedure.
- Coat O-rings with oil before installing.

Caution:

Route the sensor cable correctly.
Check sensor gap and adjust if necessary with shims (3).

Sensor gap:..... 0.45...0.55 mm (0.018 ... 0.022 in)

Tightening torque:

Sensorhandtight, 4 Nm

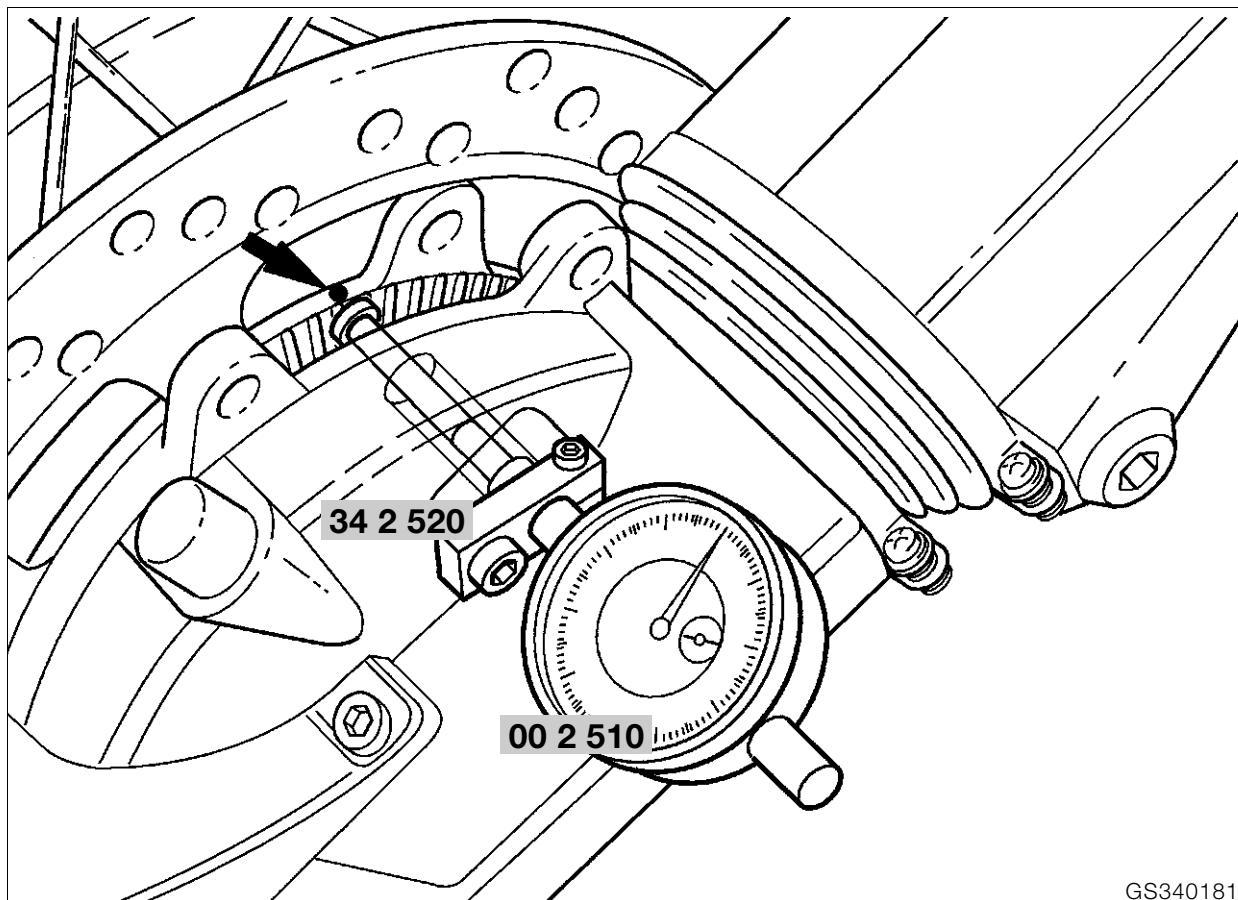
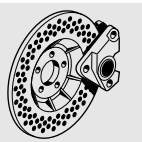

GS340181

Adjusting rear ABS sensor gap

Marking sensor wheel

- Remove rear brake caliper.
- Before removing/installing, clean the sensor bore.
- Using **Torx T 25**, remove the sensor.
- Screw dial gauge holder with measuring shoe and extension, **BMW No. 34 2 520**, with dial gauge, **BMW No. 00 2 510**, firmly to the sensor mount.
- Zero the dial gauge.
- Measure axial runout round the entire circumference.
- Using a touch-up marker, indelibly mark the point where the sensor is farthest away from the sensor ring.

Caution:

If parts are replaced (rear wheel etc.) and a used (and therefore marked) sensor ring is installed, the sensor ring must be measured and marked again. Remove the old mark.

Checking and adjusting sensor gap

- Check/adjust at the marked point.
- If necessary, remove/install sensor with **Torx T 25** and adjust sensor gap with shims.

Caution:

After adjusting, rotate the wheel and check that the sensor is clear at all times.

Sensor gap: 0.45...0.55 mm (0.018 ... 0.022 in)

Tightening torque:

Sensor..... handtight, 4 Nm

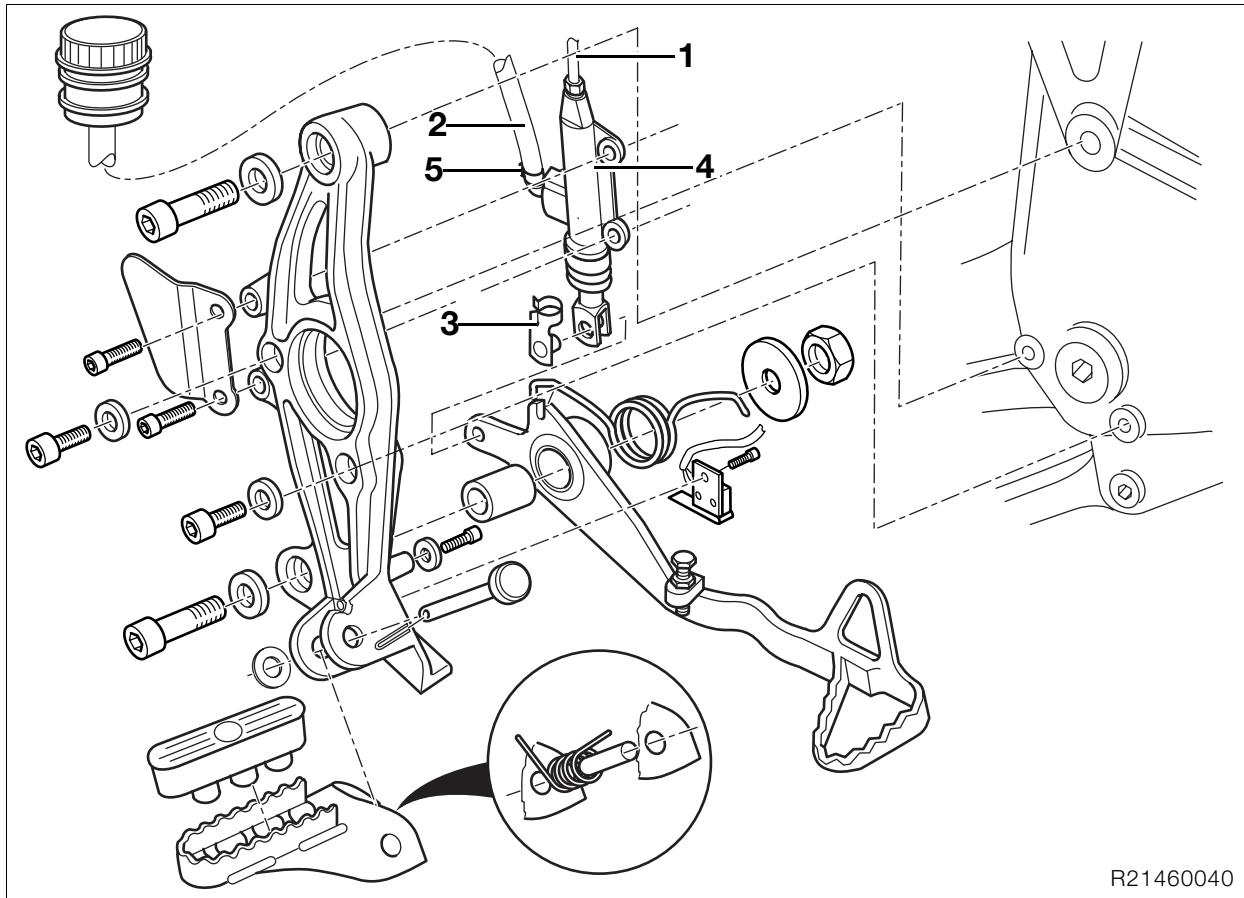

R21460040

Removing and installing rear brake master cylinder

Caution:

Do not allow brake fluid to come into contact with painted parts of the motorcycle as brake fluid destroys paint.

- Drain the brake system.
- Disconnect brake line (1) and hose (2).
- Release and remove pin (3).
- Remove brake master cylinder (4).
- Installation is the reverse of the removal procedure.
- Tighten non-reusable hose clip (5) with pliers, **BMW No. 13 1 500**.

Caution:

Bleed the brake system carefully.
Check/adjust piston rod play.



Tightening torque:

Master cylinder to footrest assembly 9 Nm

Checking and adjusting play of piston rod

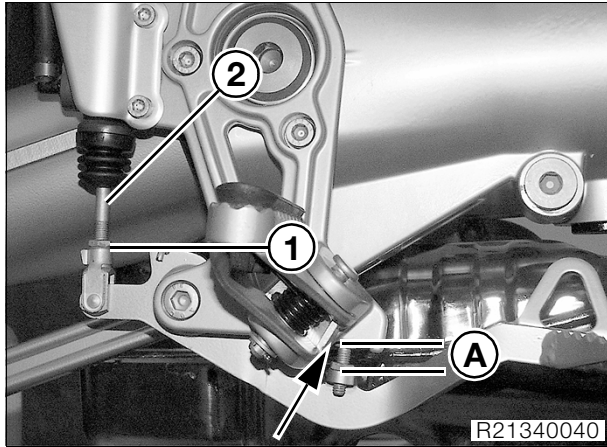

- Set the adjusting screw of the footbrake lever to distance A.

Distance A:..... 13.6 mm (0.536 in)
(Top edge of footbrake lever to top edge of adjusting screw.)

- Insert feeler gauge at right angles to direction of travel between the brake-light switch lever and the stop on the footrest plate (arrow).

Feeler gauge thickness:..... 0.2 mm (0.008 in)

- Slacken locknut (1).
- Turn piston rod (2) clockwise back into the fastener of the footrest plate to obtain play.
- Carefully back off piston rod to take up play and tighten locknut.
- Tighten locknut and recheck play.
- Apply coloured sealing lacquer to the locknut.

Removing and installing footbrake lever

- Release the pin in the brake linkage.
- Remove fasteners securing footbrake lever.
- Remove footbrake lever with torsion spring.
- Installation is the reverse of the removal procedure.
- Lubricate pivot bushing with **Shell Retinax A**.



Caution:

Check/adjust piston rod play.
See removal and installation of brake master cylinder.
The brake light must come on as soon as the rear brake begins to take effect.



Tightening torque:

Footbrake lever to footrest plate 21 Nm

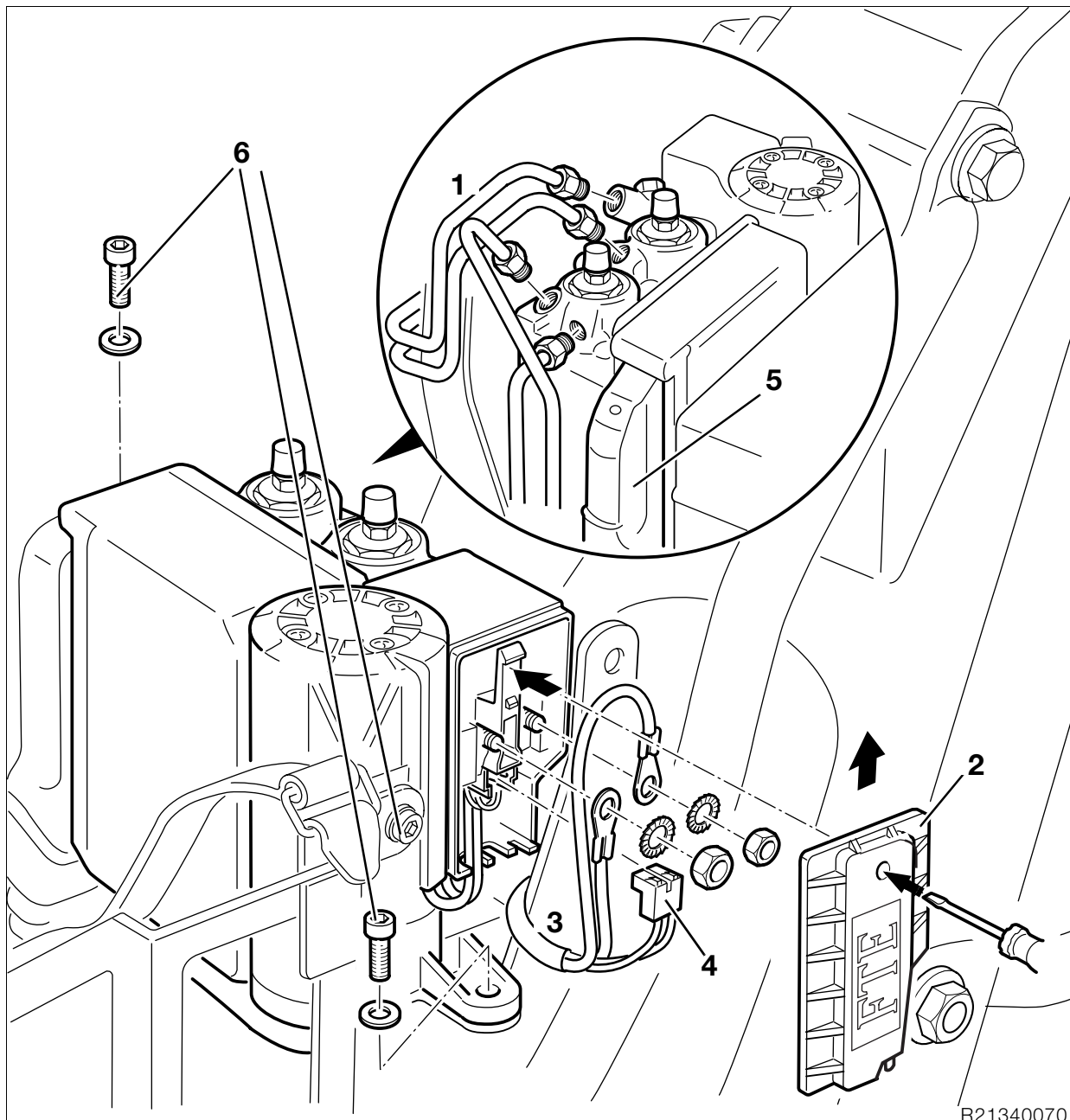

Removing and installing ABS unit



Caution:
Work on the ABS unit must be performed by an authorised BMW workshop.

Removing the ABS unit

- Remove fuel tank.
- Disconnect ABS brake lines (1) from ABS unit.



Caution:
If brake fluid escapes, it may damage paint. Line connections **must** be protected against dirt penetration; seal or cover ends of lines and ports.

- Hold the front brake lever against the handlebar grip with a rubber band (to close the brake fluid feed bore).



Caution:
Switch off ignition.
Disconnect earth (ground) lead from battery.
Insulate earth (ground) lead.

- Remove cover (2) from ABS control unit, press the lock in with a screwdriver and pull the cover up.
- Disconnect cables (3).
- Pull off 2-pin plug (4).
- Pull off the central plug (5).
- Remove the ABS unit (6).

Installing the ABS unit

- Install the ABS unit (6).
- Connect the central plug (5).

Caution:

Make sure the cable is not at an angle, or its insulation may be damaged.

- Reconnect the 2-pin plug in the correct position, pushing the two halves fully together, and press the two wires into the center (smaller) cable entries.
- Push the two plugs for the connecting cable/wiring harness onto the threaded pins with the crimp at the front.
- Press the two cables into the remaining free cable entries.
- Tighten the nuts.

Caution:

Always use new self-locking nuts.

Tightening torque:

Battery -/M 5 3.5 Nm
 Battery +/M 4 3 Nm

- Install a new cover.

Caution:

When sliding the cover on, make sure that all cables are correctly located in their cable entries. **Scrap** the old cover.

- Screw ABS brake lines (1) to ABS unit.
- Fill and bleed the brake system.
- Install the fuel tank.

Tightening torque:

ABS unit to holder 8 Nm
 ABS unit to battery carrier (Torx) 5 Nm
 Brake line to ABS unit 18 Nm
 Bleed screw on ABS unit 14 Nm

Removing and installing ABS relay and relay socket

Removing ABS relay

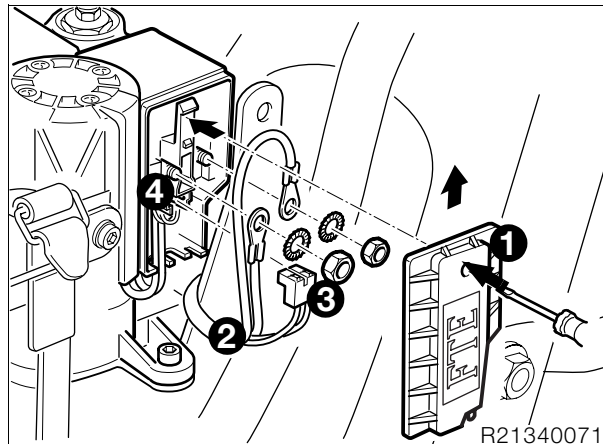

Caution:

Switch off ignition.
 Disconnect earth (ground) lead from battery.
 Insulate earth (ground) lead.

- Remove cover (1) from ABS control unit, press the lock in with a screwdriver and pull the cover up.
- **Scrap** the old cover (1).
- Disconnect lines (2) and **discard** nuts.

Caution:

Make sure the cable is not at an angle, or its insulation may be damaged.

- Pull off 2-pin plug (3).
- Remove relay socket (4).
- **Back off** screws on relay socket by app. 2 turns with **Torx T20**.
- Pull the relay up to remove.

Installing the ABS relay

- Insert the ABS relay with the FAG logo facing the detent hook.
- Tighten the screws at the relay socket.
- Push the relay socket into the relay housing, at the same time pressing both engine cables into the left cable entries on the relay housing (red at back, black at front).
- Secure black engine cable to left threaded pin (M 5) with crimp at rear.

Caution:

Make sure the cable is not at an angle, or its insulation may be damaged.

-
- Reconnect the 2-pin plug in the correct position, pushing the two halves fully together, and press the two wires into the center (smaller) cable entries.
 - Push the two plugs for the connecting cable/wiring harness onto the threaded pins with the crimp at the front.
 - Press the two cables into the remaining free cable entries.
 - Tighten the nuts.

Caution:

Always use new self-locking nuts.

-
- Install a new cover (1).

Caution:

When sliding the cover on, make sure that all cables are correctly located in their cable entries. **Scrap** the old cover.

Removing ABS relay socket

Caution:

Switch off ignition.
Disconnect earth (ground) lead from battery.
Insulate earth (ground) lead.

-
- Remove cover (1) from ABS control unit, press the lock in with a screwdriver and pull the cover up.
 - **Scrap** the old cover (1).
 - Disconnect lines (2) and **discard** nuts.

Caution:

Make sure the cable is not at an angle, or its insulation may be damaged.

-
- Pull off 2-pin plug (3).
 - Remove relay socket (4).
 - Remove screws at relay socket with **Torx T20**.
 - Remove the ABS relay.
 - Press the contact interlock out of the relay base.
 - Release the plug from the relay side using special tool,
No. 50000-017-507
from the **Grote und Hartmann** company.

Caution:

The contact has a double detent.
When pulling the plug out of the relay socket, avoid applying too much tension to the cable.
The entire ABS unit must be replaced if the cable breaks.

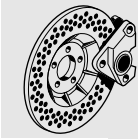

Installing the ABS relay base

- Bend up the contact interlock on the plug.
- Insert the contact into the relay socket.



Caution:

The contact engages with an audible click and must be firmly located.

- Insert the ABS relay with the FAG logo facing the detent hook.
- Insert a Torx screw into the ring shoe of the red engine cable.



Note:

The crimp side is towards the screw head.



Caution:

The same Torx screws must be re-used because of their self-locking effect.

When inserting the screws again, make sure that they pick up with the existing thread in the sheet-metal element.

Failing this, vibration could cause the screws to work loose.

- Place the ring shoe (with two cables) on the bore of the insert at the rear of the relay socket, with the crimp side towards the relay socket, and screw on together with the red engine cable, using the Torx screw.
- Use the second Torx screw to secure the flat plug to the relay.
- Press the contact interlock into the relay socket at the side.
- Push the relay socket into the relay housing, at the same time pressing both engine cables into the left cable entries on the relay housing (red at bottom, black at top).
- Secure black engine cable to left threaded pin (M 5) with crimp at rear.



Caution:

Make sure the cable is not at an angle, or its insulation may be damaged.

- Reconnect the 2-pin plug in the correct position, pushing the two halves fully together, and press the two wires into the center (smaller) cable entries.
- Push the two plugs for the connecting cable/wiring harness onto the threaded pins with the crimp at the front.
- Press the two cables into the remaining free cable entries.
- Tighten the nuts.



Caution:

Always use new self-locking nuts.

- Install a new cover (1).



Caution:

When sliding the cover on, make sure that all cables are correctly located in their cable entries.

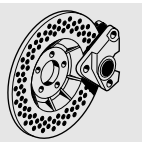

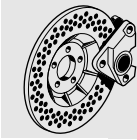
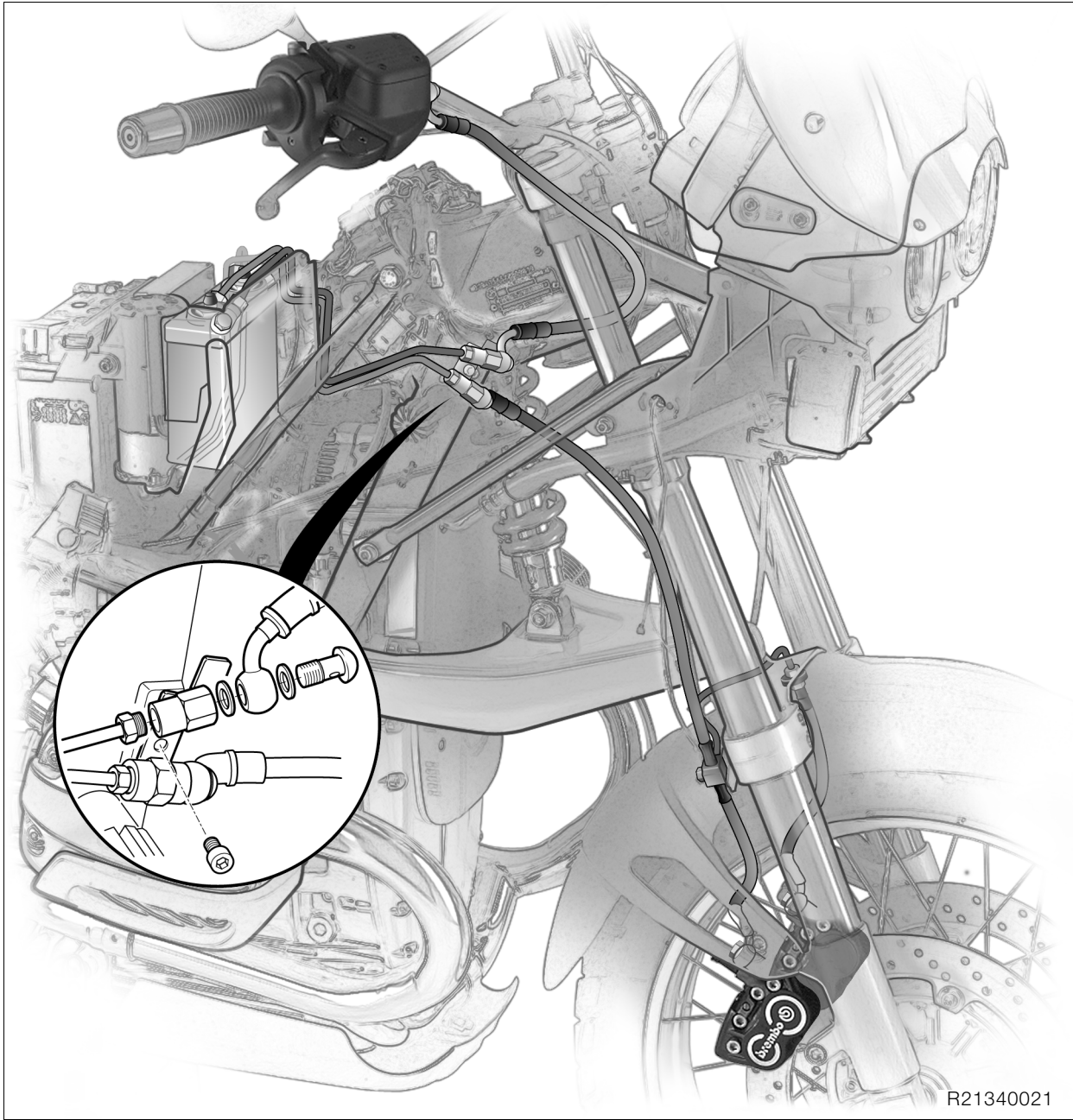

**Removing and installing brake line
(with ABS)**

Removing and installing front brake
line

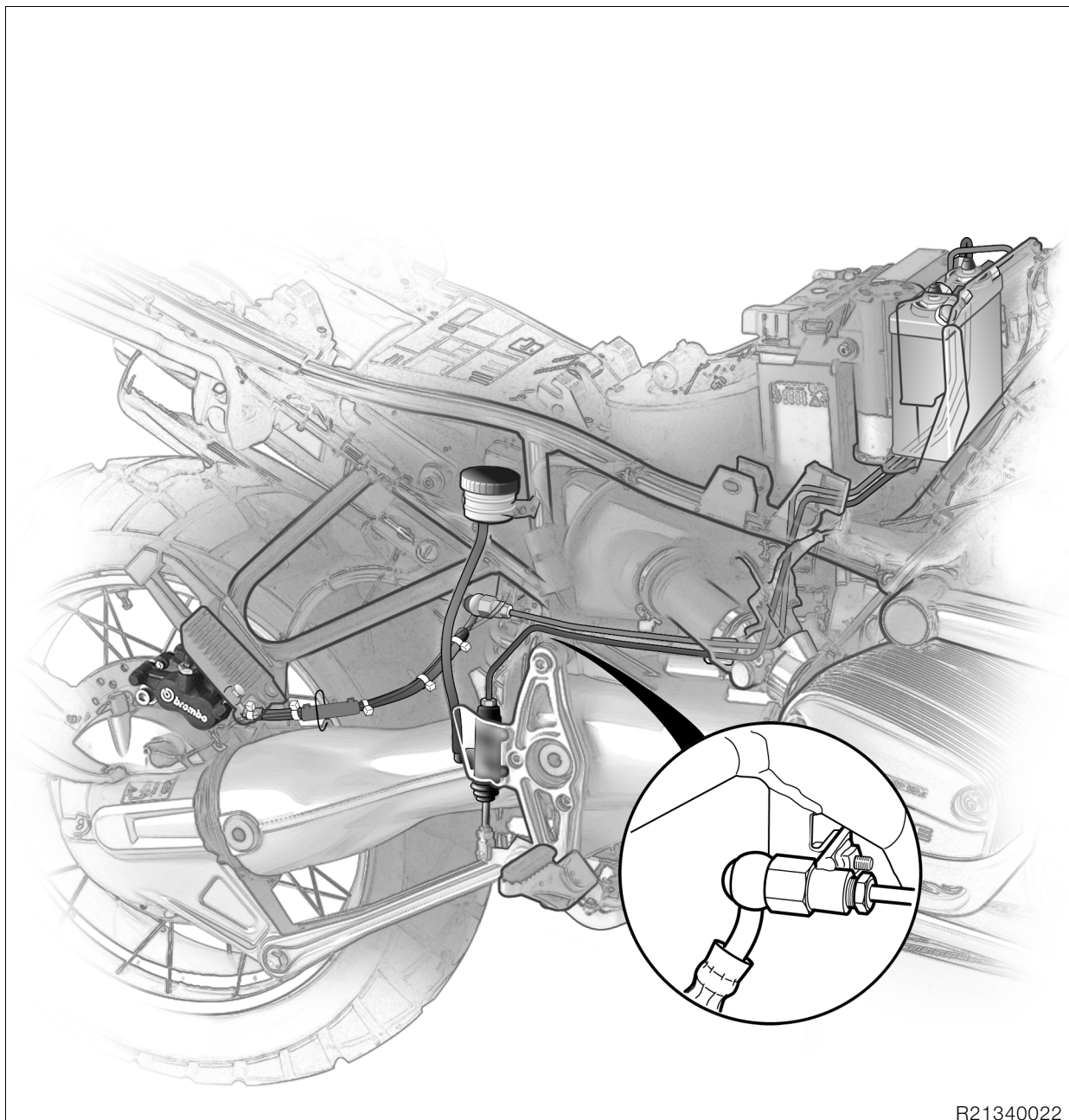
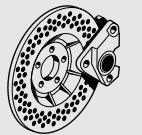

R21340022

Removing and installing rear brake line

Caution:

Do not allow brake fluid to come into contact with painted parts of the motorcycle as brake fluid destroys paint.

- Drain the brake system.
- **[ABS]** Remove the fuel tank.
- Remove brake lines.
- Installation is the reverse of the removal procedure.

Caution:

Remove sealing rings for brake line.
Secure brake line to master cylinder in such a way that it cannot kink or chaff when the handlebar is turned.

- Fill and bleed the brake system

Tightening torque:

Brake line to handlebar fitting	18 Nm
Brake line to front/rear brake caliper	18 Nm
Brake hose to bracket	9 Nm
Bleed screw in rear brake caliper	6 Nm
Bleed screw in front brake caliper	14 Nm
Bleed screw on ABS unit	14 Nm
Bracket to front frame	9 Nm
Bracket to rear frame	9 Nm
(clean thread + Loctite 2701)	9 Nm
Bracket to slider tube bridge	
(clean thread + Loctite 2701)	5 Nm
Brake line to ABS unit	18 Nm

36 Wheels and tyres

Contents

Page

Technical Data	3
Removing and installing front wheel	5
Removing front wheel	5
Installing the front wheel	5
Removing and installing wheel bearings	6
Removing/installing rear wheel	8
Removing rear wheel	8
Installing rear wheel	8
Static balancing of front wheel/rear wheel	9
Checking front/rear wheel rim for runout	10
Removing/installing spokes	11
Centering the wheel rim	11
Centering lateral runout	11

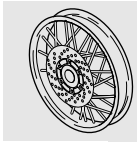

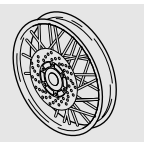

Technical Data			R 1150 GS
Rim size	Front		2.50 x 19 MT H2
	Rear		4.00 x 17 MT H2
Max. radial/lateral runout	Front	mm (in)	Spoked wheel 1.3 (0.05)
	Rear	mm (in)	1.3 (0.05)
Tyre size	Front		Spoked wheel 110/80 R 19 59 H Tubeless
	Rear		150/70 R 17 69 H Tubeless
Tyre pressures (cold)			
Solo	Front	bar (psi)	2.2 (31.9)
	Rear	bar (psi)	2.5 (36.3)
Two-up	Front	bar (psi)	2.5 (36.3)
	Rear	bar (psi)	2.7 (42.0)
Two-up and luggage	Front	bar (psi)	2.5 (36.3)
	Rear	bar (psi)	2.9 (45.1)

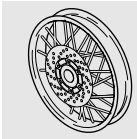

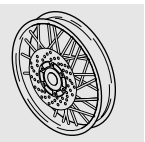

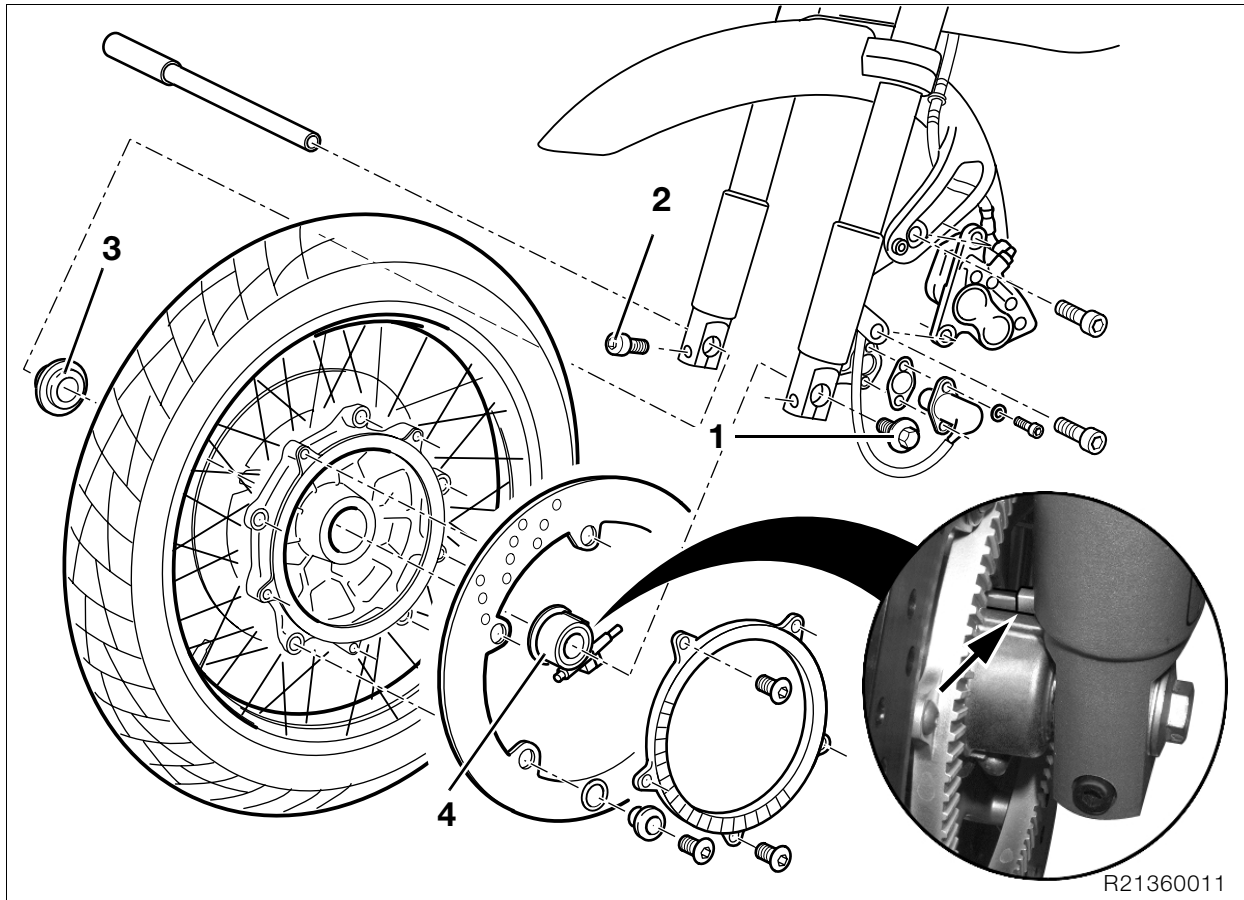

Removing and installing front wheel

Removing front wheel

- Remove brake calipers.



Note:

Do not apply handbrake lever with brake calipers removed/front wheel removed.

- Remove retaining screw (1).
- Loosen clamping screws (2).
- Remove quick-release axle.
- Remove spacer bushing (3) and speedometer drive (4).
- Remove front wheel.

Installing the front wheel

- Fit the front wheel.
- Install the spacing bushing and speedometer drive.



Caution:

Locate the reaction peg (arrow) on the speedometer drive in front of the fork slider tube.

- Apply a light coating of **Molykote paste** to the quick-release axle and install it.
- Tighten the retaining screw (1).
- Compress the front fork firmly several times.
- Tighten the clamping screws (2).
- Install the brake calipers.
- **[ABS]** Check sensor gap and adjust if necessary.

ABS sensor gap:
 0.45...0.55 mm (0.018 ... 0.022 in)



Tightening torque:

Quick-release axle threaded connection 30 Nm
 Clamp screws, sliding tube 22 Nm
 Brake caliper to fork slider tube..... 40 Nm

Removing and installing wheel bearings

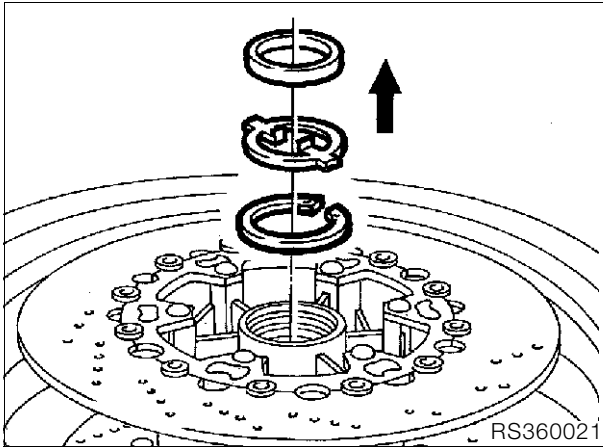

- Carefully lever out the shaft sealing ring with a screwdriver.
- Remove driver and retaining ring.

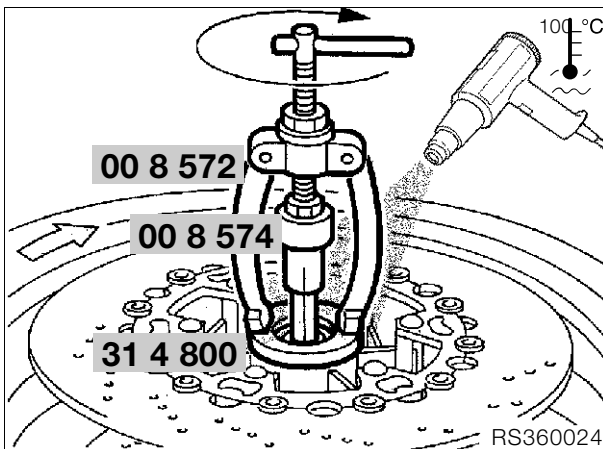

- Clamp a drift, **BMW No. 36 5 511**, into the vise and place the wheel on it with the wide bearing down.
- Place a spacing ring, **BMW No. 31 4 800**, between the wheel hub at the right and the claws of the internal puller.
- Heat bearing seat to 100 °C (212 °F).
- Pull out the wheel bearing with counter-support 22/1, **BMW No. 00 8 572**, and internal puller 21/3, **BMW No. 00 8 574**.

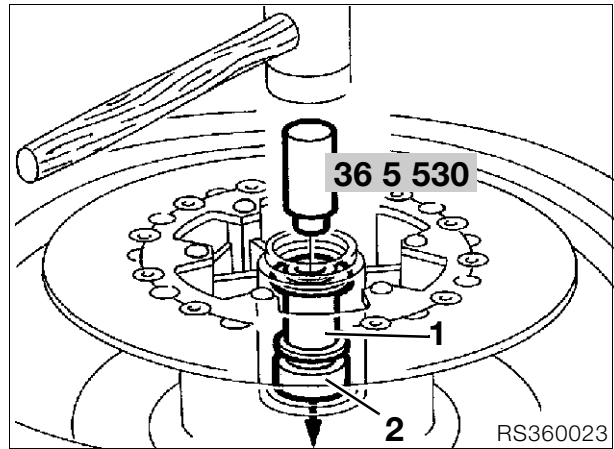

- Press out spacing bushing (1) and wheel bearing (2) with drift, **BMW No. 36 5 530**.
- Use drift, **BMW No. 36 5 530**, to press reducing sleeve out of original bearing and into new bearing.
- Degrease bearing seats.

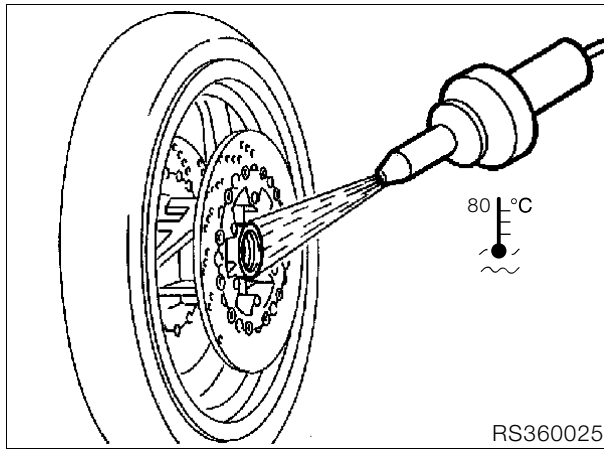

- Heat bearing seat to 80°C (176 °F).

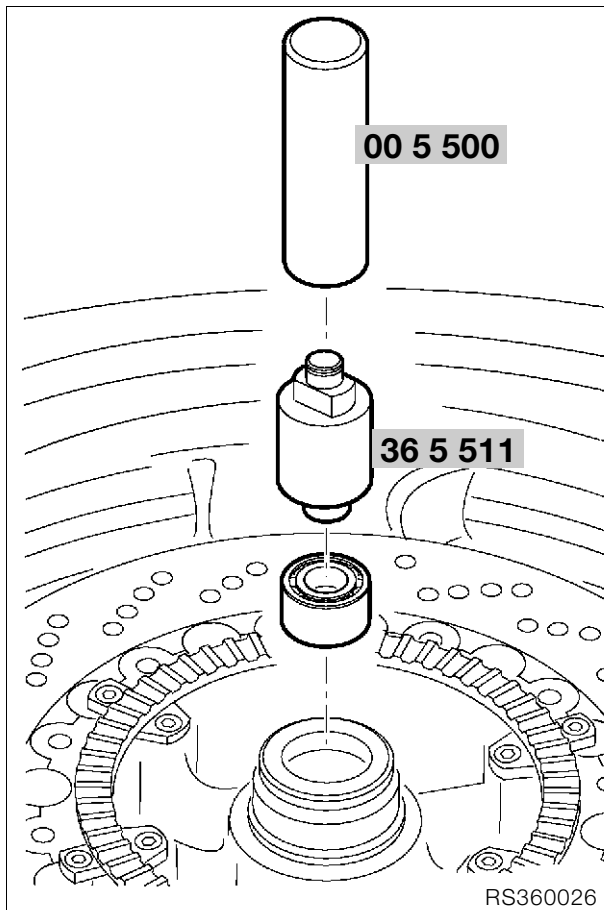

- **First** insert wide bearing using drift, **BMW No. 36 5 511**, and handle, **BMW No. 00 5 500**.

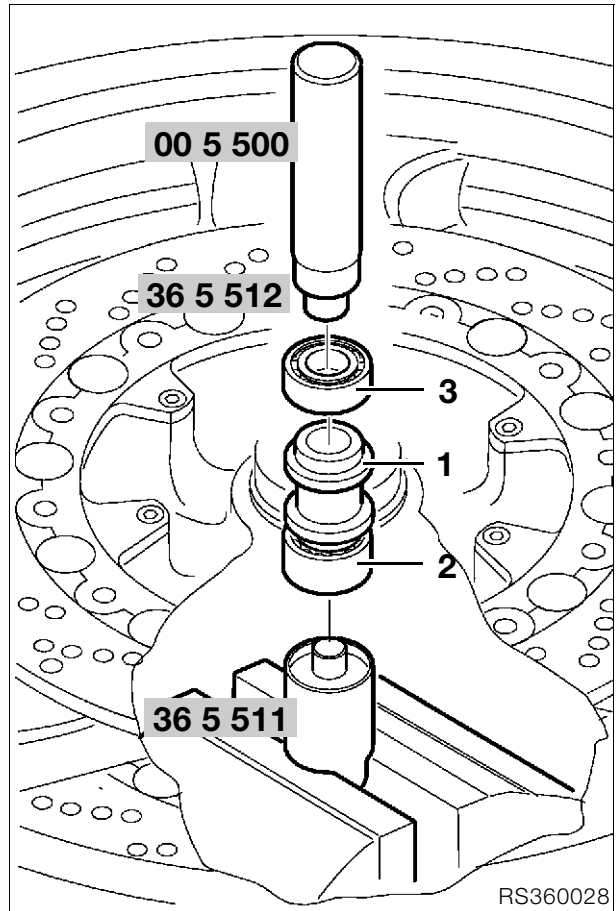

- Clamp a drift, **BMW No. 36 5 511**, into the vise and place the wheel on it with the wide bearing (2) down.
- Install spacer tube (1).
- Bearing seat temperature 80 °C (176 °F).
- Insert narrow bearing (3) with drift, **BMW No. 36 5 512**, and handle, **BMW No. 00 5 500**.

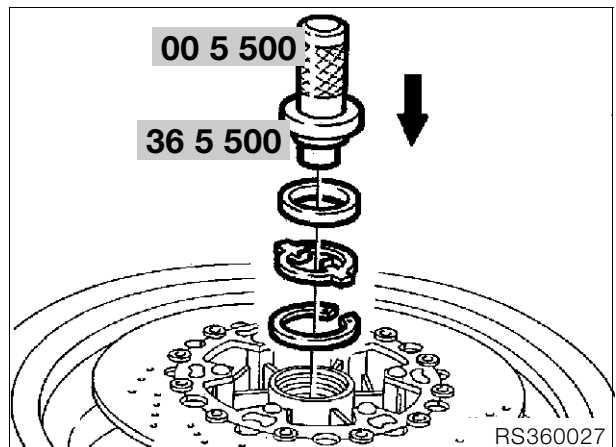

- Install retaining ring and driver.
- Drive in shaft sealing ring with drift, **BMW No. 36 5 500**, and handle, **BMW No. 00 5 500**.



Note:

When installing the wheel, make sure that the driver is located in its guide.

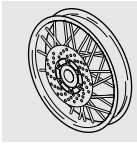

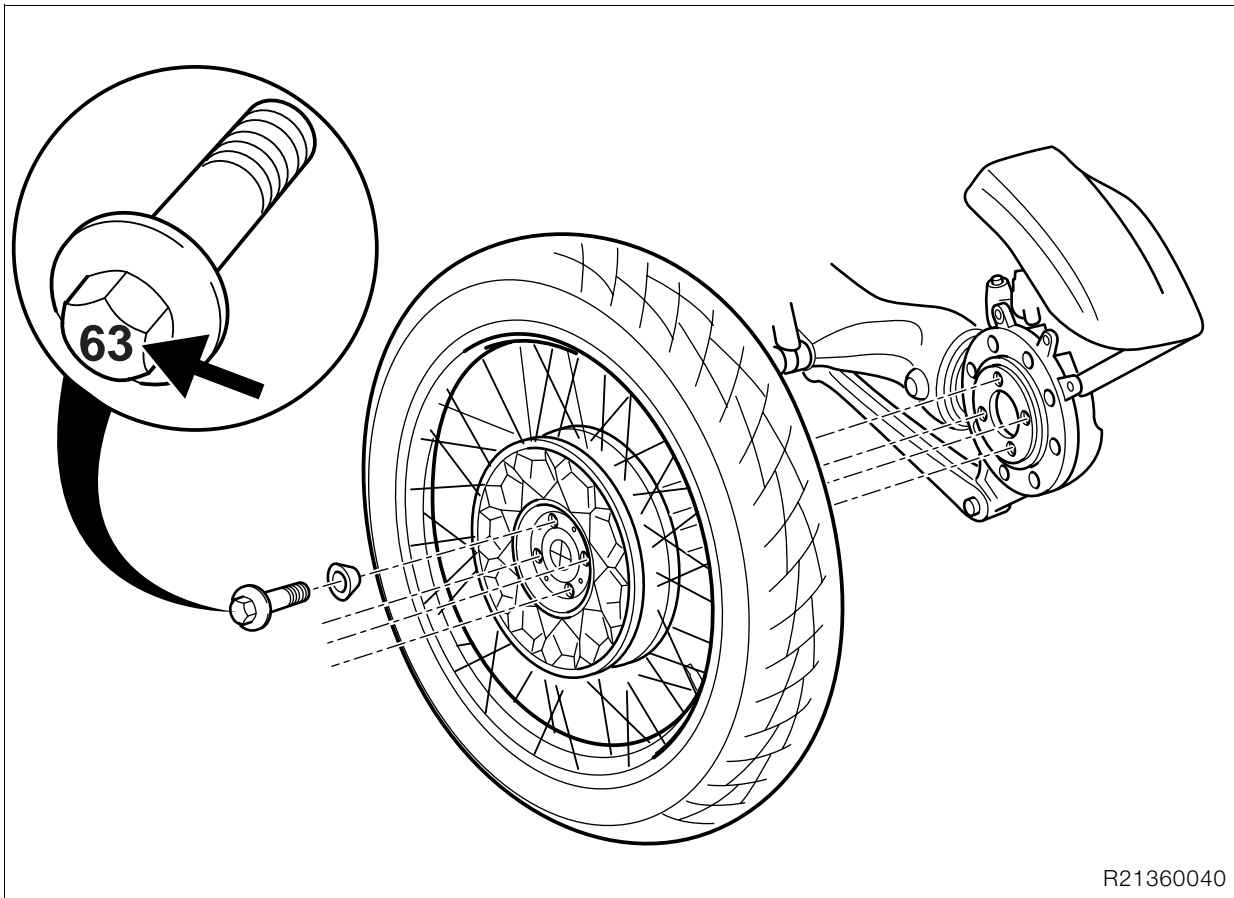

Removing/installing rear wheel

Removing rear wheel



Caution:

Do not operate the brake pedal when the brake caliper is removed.

- Remove brake caliper.



Note:

Carefully bend the rear wheel cover to the right to permit wheel removal, but do not remove the cover. Screws are secured with Loctite.

- Remove wheel studs with taper rings.
- Remove the rear wheel.

Installing rear wheel



Caution:

Contact faces on rear wheel drive and hub must be clean and free of grease.

- Hold rear wheel in position at rear wheel drive and high-tighten the wheel studs with taper rings.



Caution:

Use only wheel studs with length code 63. Do not oil or grease wheel studs!

- Tighten the wheel studs.
- Install brake caliper.
- **[ABS]** Check sensor gap and adjust if necessary.

ABS sensor gap 0.45...0.55 mm (0.018 ... 0.022 in)



Tightening torque:

Screw in wheel studs handtight, then tighten in diagonally opposite sequence
 Initial tightening 72 Nm
 Final tightening 105 Nm

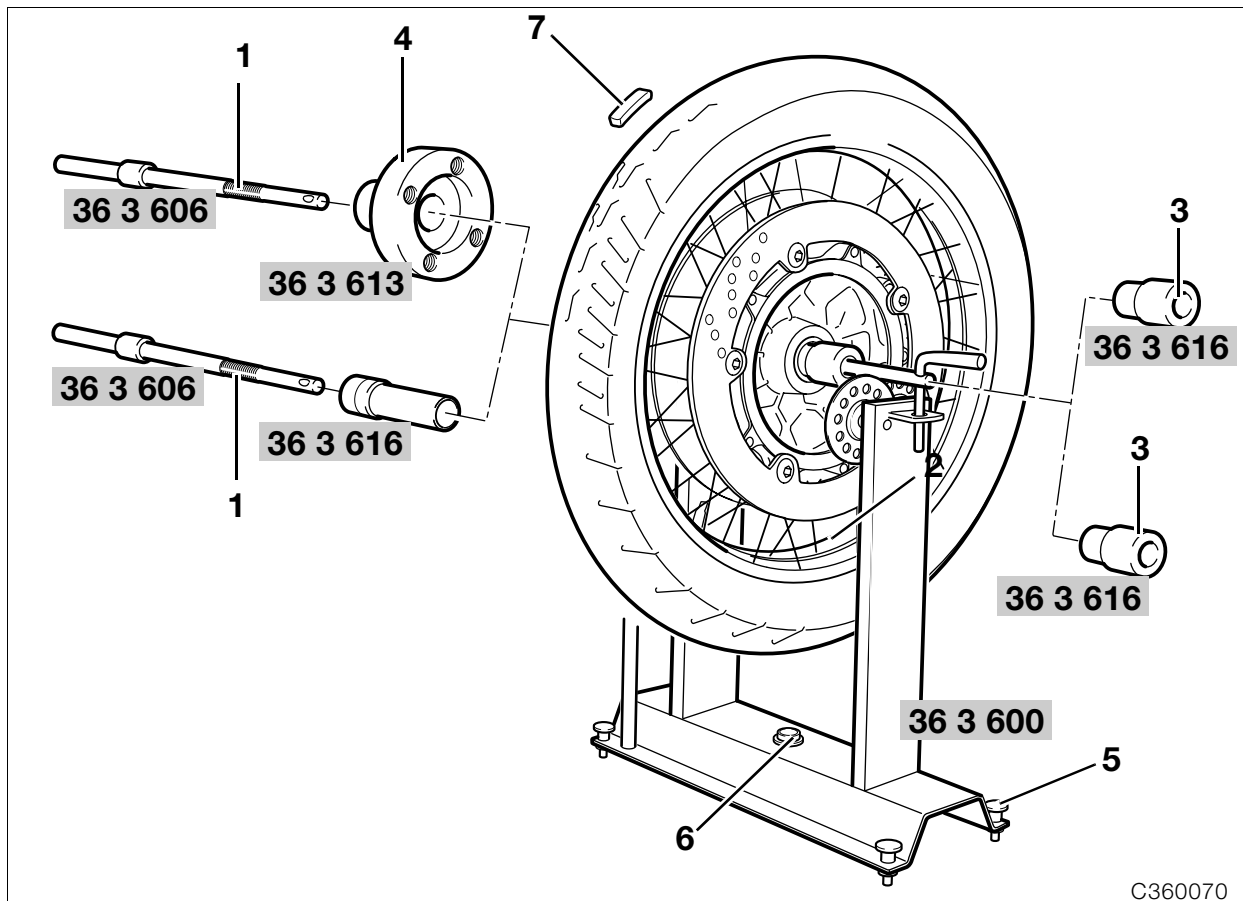

C360070

Static balancing of front wheel/rear wheel

- Level balancing stand, **BMW No. 36 3 600**, using knurled-head screws and bubble gauge (5/6).
- Install balancing shaft (1), **BMW No. 36 3 606**, with measuring bushing (2), **BMW No. 36 3 616**, and nut (3), in front wheel bearings.
- Lightly preload bearing with knurled nut (3).
- At the rear wheel, attach mounting fixture (4), **BMW No. 36 3 613**, on the centering collar side with the wheel studs and shims, then install the balancing shaft.
- Allow wheel to settle.
- Clean the attachment points for the adhesive weights.
- Affix the adhesive weights (7) uniformly spaced on both sides of the rim opposite the wheel's heaviest point.



Caution:

Maximum balancing weight 80 g (2.82 oz).

- Repeat the balancing procedure as a check.

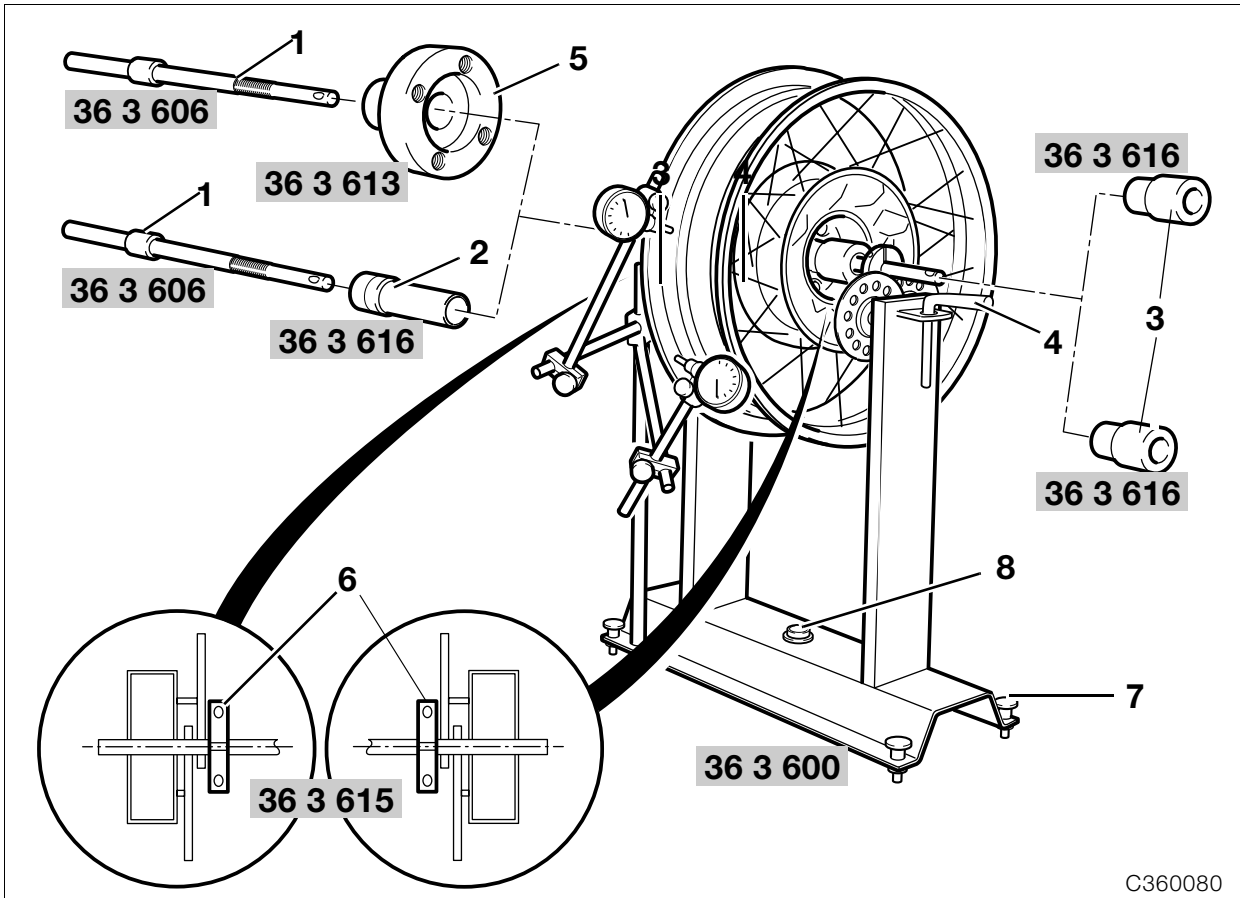

C360080

Checking front/rear wheel rim for runout

- Remove tyre.
- Install balancing shaft (1), **BMW No. 36 3 606**, with measuring bushing (2) and nut (3), **BMW No. 36 3 616**, in front wheel bearings.
- Lightly preload bearing with knurled nut (3).
- Use pin (4) to lock the balancing shaft against the balancing stand to prevent the shaft from turning.
- At the rear wheel, attach mounting fixture (5), **BMW No. 36 3 613**, on the centering collar side with the wheel studs and shims, then install the balancing shaft.
- Clamp locating discs (6), **BMW No. 36 3 615**, to the balancing shaft at left and right in such a way that the shaft cannot wander.
- Level balancing stand, **BMW No. 36 3 600**, using knurled-head screws and bubble gauge (7/8).
- Check radial/axial runout.



Caution:

Bring the dial gauge stylus into contact only with the machined inner face of the wheel rim.

Max. radial runout/lateral runout:

Spoked wheel

front/rear 1.3 mm (0.05 in)

Removing/installing spokes

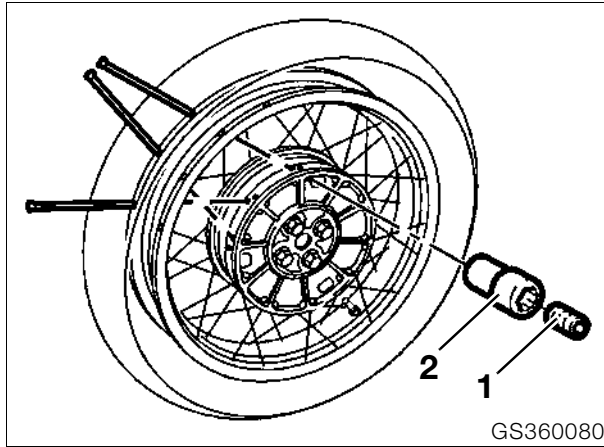

Caution:

It is not permitted to replace more than one spoke.

- Unfasten grub screw (1).
- Loosen the spoke nipple (2) and remove the spoke.
- Install new spoke.
- Center the wheel rim.



Tightening torque:

Spoke nipple 3.5 Nm - 5 Nm

Centering the wheel rim

Max. permissible lateral/vertical runout..... 1.3 mm (0.05 in)
Max. horizontal runout which can be eliminated by centering 2.0 mm (0.08 in)



Note:

Vertical runout cannot be compensated for by centering the rim.

Centering lateral runout

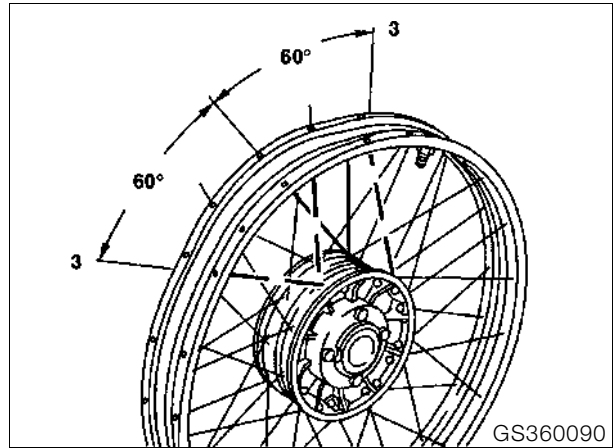

- Determine maximum deviation (plus (+) and minus (-)).



Note:

To center the wheel, the spoke nipples must be tightened on the side directly opposite the largest deviation.

- Remove grub screw from relevant spoke nipple before tightening.
- Working forwards and backwards from the point opposite the maximum and minimum value points, take up slack at every third spoke nipple.
- Then working forwards and backwards from the point opposite the maximum and minimum value points, take up slack at every second spoke nipple.



Caution:

Never attempt to compensate for the entire horizontal runout at only one or two spokes.

- Four spokes are therefore tightened during each centering operation.
- Check horizontal runout with a dial gauge.
- After every correction of horizontal runout, re-check vertical runout.
- If necessary, repeat the centering operation.
- Lock tightened spokes into place with grub screws.



Tightening torque:

Spoke nipple 3.5 Nm - 5 Nm
 Grub screw 1 Nm

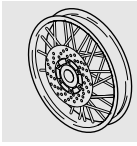

46 Frame

Contents

Page

Technical Data	3
Overall view, frame	5
Removing and installing main (centre) stand	6
Removing and installing side stand	7
Removing and installing front mudguard	8
Removing and installing bottom section of mudguard	8
Removing and installing top section of mudguard	9
Removing and installing windscreen	10
Removing and installing fairing bracket	11
Removing and installing luggage rack	12
Removing and installing number-plate carrier	13
Removing/installing rear mudguard	14
Removing and installing rear footrest plate	15
Removing and installing front footrest plate	16
Removing and installing right footrest plate	16
Removing and installing left footrest plate	17
Removing/installing frame	18
Removing and installing frame tail section	19
Checking running gear	20
Measuring wheel track offset	20
Measuring the leading link	22





Technical Data		R 1150 GS
Location of manufacturer's type plate/frame number		On frame, at right
Length, overall	mm (in)	2189 (86.2)
Max. height without mirrors	mm (in)	1366 (53.8)
Width of handlebar with weights	mm (in)	903 (35.6)
Width across rear footrests	mm (in)	734 (28.9)
Height of seat at unladen weight	mm (in)	840/860 (33.1/33.9)
Wheelbase in normal-load position	mm (in)	1509 (59.4)
Ground clearance in normal-load position	mm (in)	200 (7.9)
Caster angle in normal-load position	mm (in)	115 (4.5)
Steering head angle in normal-load position	°	62.9
Cornering angle limit with 85 kg (187 lbs) rider	°	47
Wheel track offset		
normal	mm (in)	+ 3 mm (0.12) (= to right)
max.	mm (in)	± 9 mm (0,35 in): datum is + 4.5 mm (0.18 in)
Unladen weight, ready for road, full tank	kg (lbs)	249 (548,9)
Axle load distribution (without rider), front/ rear	%	50/50
Permitted gross weight	kg (lbs)	460 (1014.1)



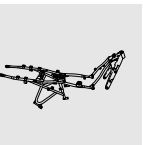

Overall view, frame

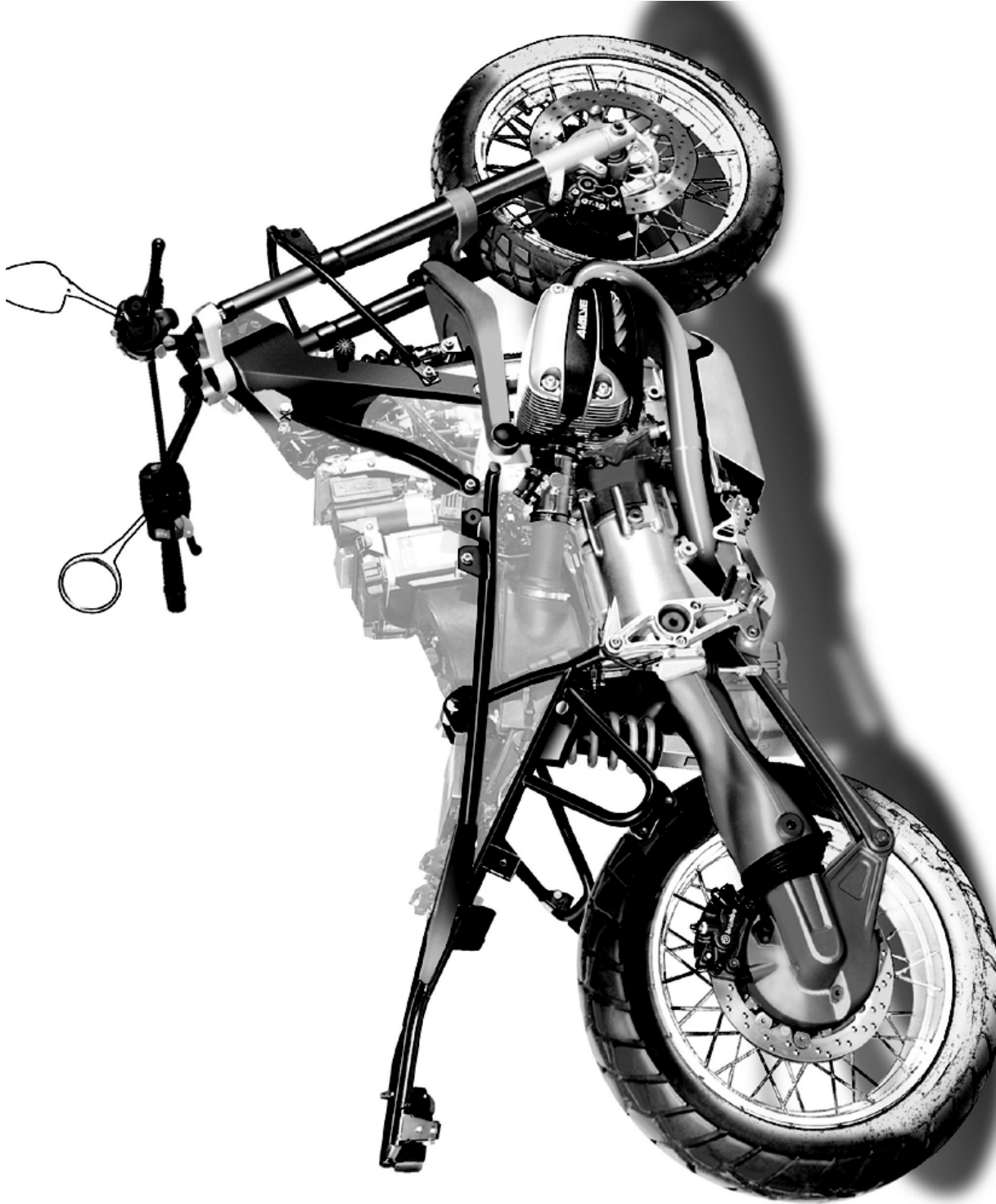

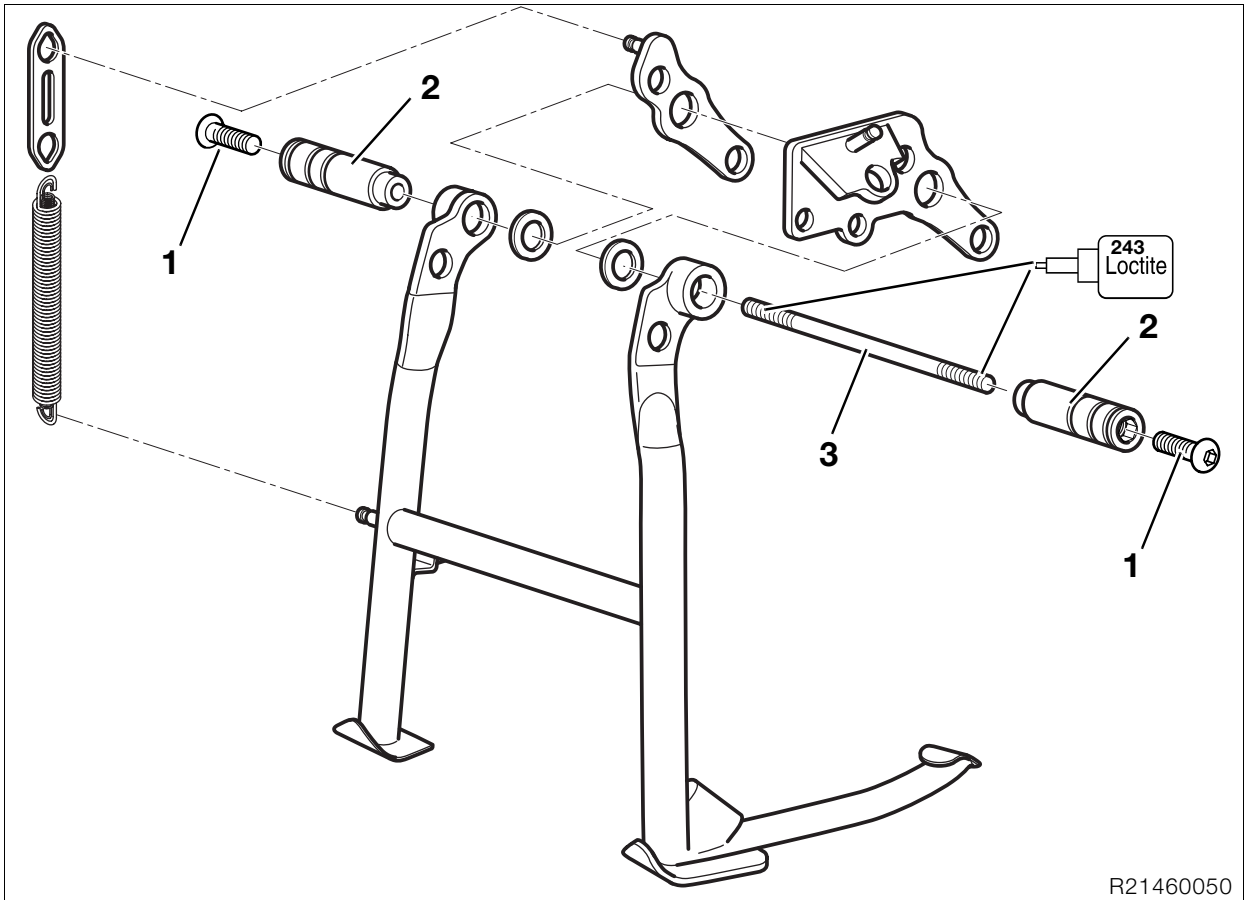

R21460050

Removing and installing main (centre) stand

- Remove the sump guard.

- Disconnect the plug from the side stand switch.
- Remove the main (centre) stand.
- Remove right and left bearing blocks (2).
- Installation is the reverse of the removal procedure.

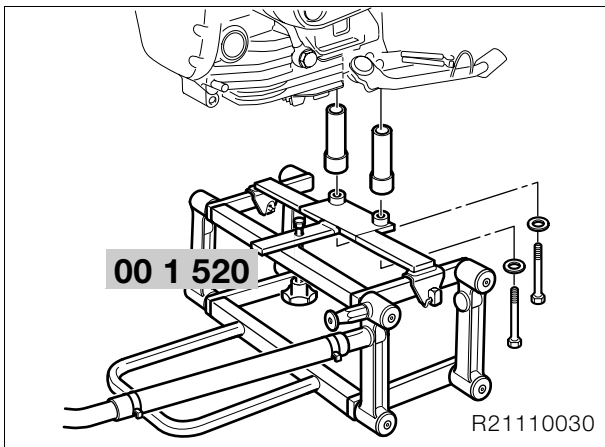

- Secure stand, **BMW No. 00 1 520**, to motorcycle with overlength bushes and screws, **BMW No. 00 1 527**.



Note:

Mount a washer on the screw on the right as viewed in the forward direction of travel.
Depth of thread in tapped bore has been reduced!

- Disconnect tension springs.
- Remove machine screws (1) in bearing bushings (2).
- Remove right and left bearing bushings (2).

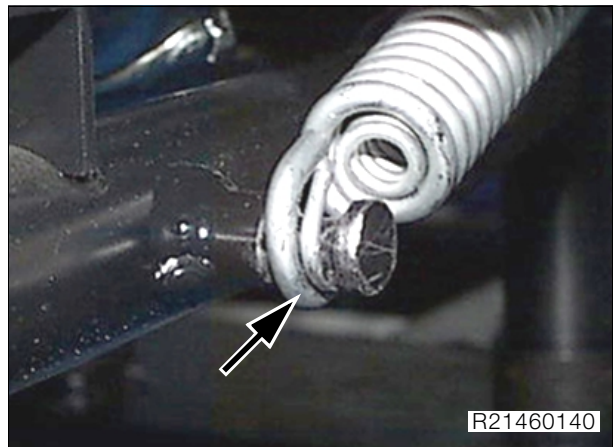

Note:

When installing the springs, make sure that the thick spring is on the inside and the thin spring on the outside (arrow).

Lubricant:

for pivot bushings..... Staburags NBU 30 PTM

**Tightening torque:**

Pivot mounts of main stand, M 8 (stud (3)) (clean thread + Loctite 243).....	21 Nm
Pivot mount of main (centre) stand M 8 (machine screw)	21 Nm
Carrier plate to engine block M 12 (machine screw) (clean thread + Loctite 2701).....	72 Nm
Carrier plate to engine block M 8 (countersunk screw)	21 Nm
Carrier plate to engine block, left, M 8 (machine screw)	21 Nm

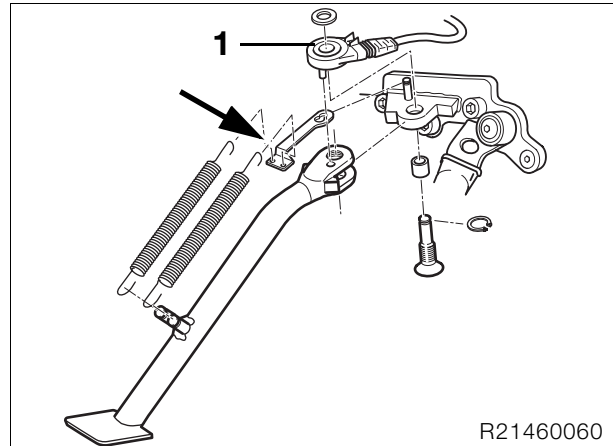
Removing and installing side stand

- Place the motorcycle on its main (centre) stand.
- Disconnect tension springs.
- Disconnect plug (1) from the side-stand switch and remove the switch.
- Remove side stand.
- Installation is the reverse of the removal procedure.

**Note:**

When installing, make sure that the offset is correctly positioned (arrow) relative to the spring retainer.

**Caution:**

Note routing of cables.

Lubricant:..... Staburags NBU 30 PTM

**Tightening torque:**

Side stand to pivot mount
(clean thread + Loctite 2701)..... 58 Nm



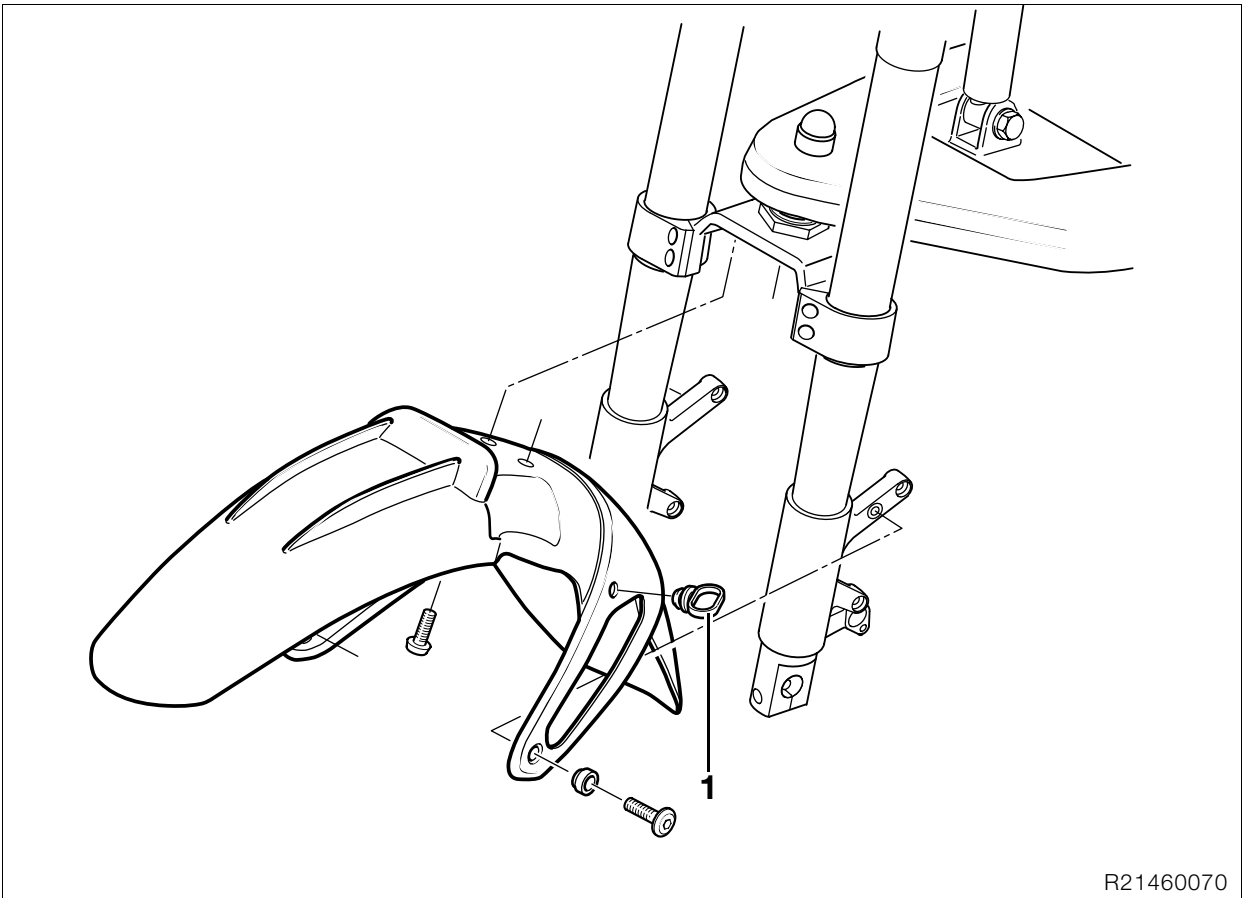

R21460070

Removing and installing front mudguard

Removing and installing bottom section of mudguard

- Remove front wheel.
- Remove holder (1) for speedometer drive.
- Remove mudguard.
- Installation is the reverse of the removal procedure.



Tightening torque:

Mudguard to slider tube	4 Nm
(clean thread + Loctite 2701)	
Mudguard to slider tube bridge	5 Nm
(clean thread + Loctite 2701)	

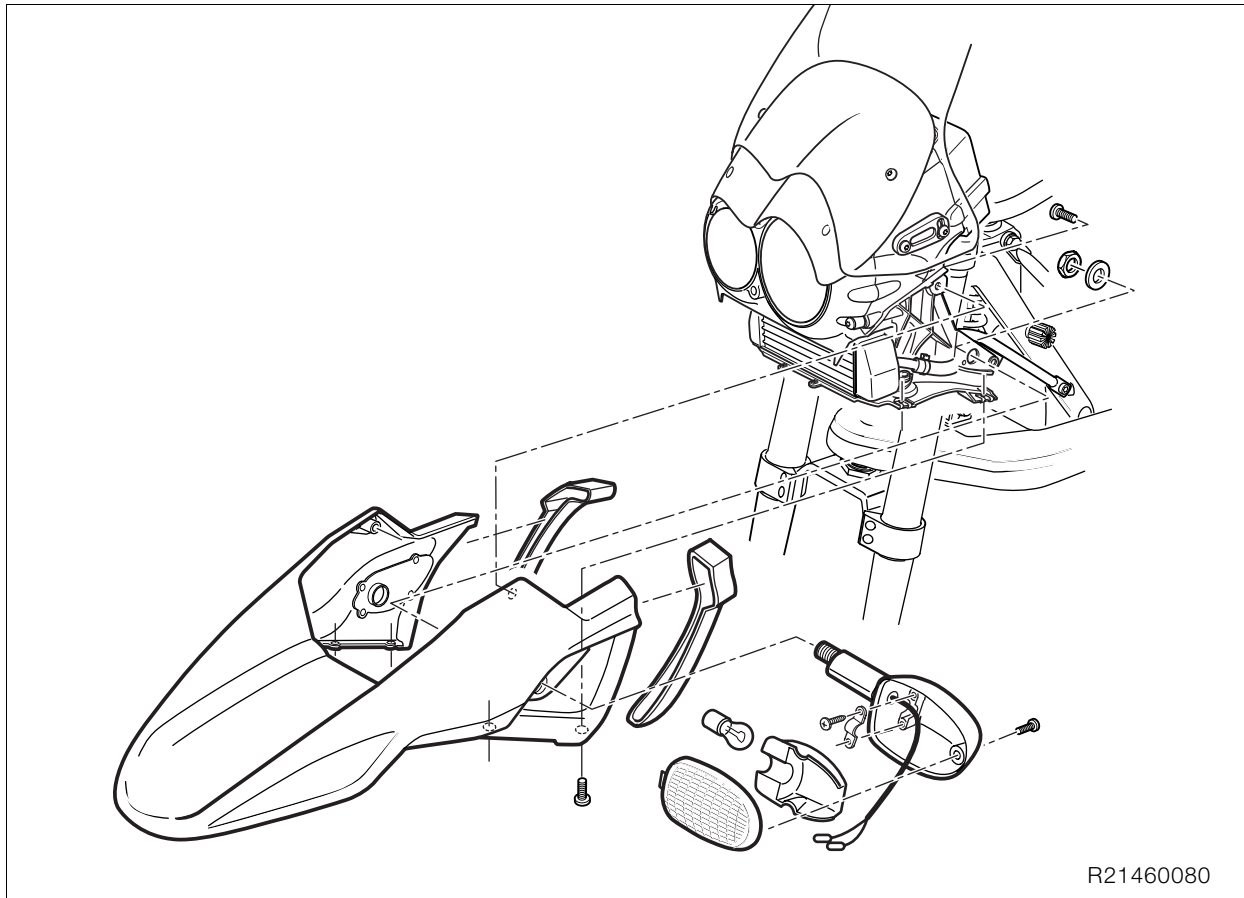

Removing and installing top section of mudguard



Caution:

Switch off ignition.
Disconnect earth (ground) lead from battery.
Insulate earth (ground) lead.

- Remove the indicator lenses, disconnect plug and pull the cable through the indicator mount.
- Remove the turn indicators.
- Remove mudguard.
- Installation is the reverse of the removal procedure.

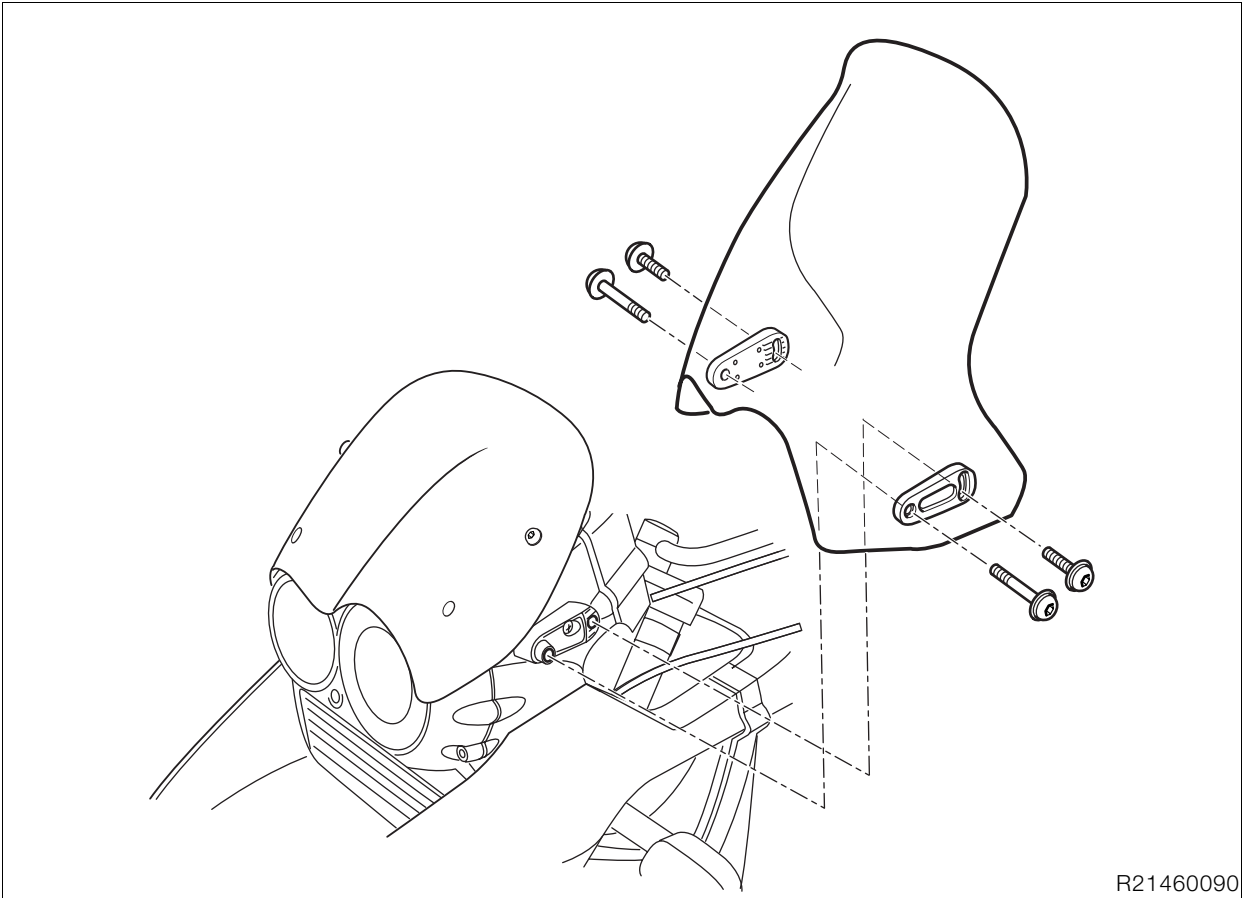

R21460090

Removing and installing windscreen

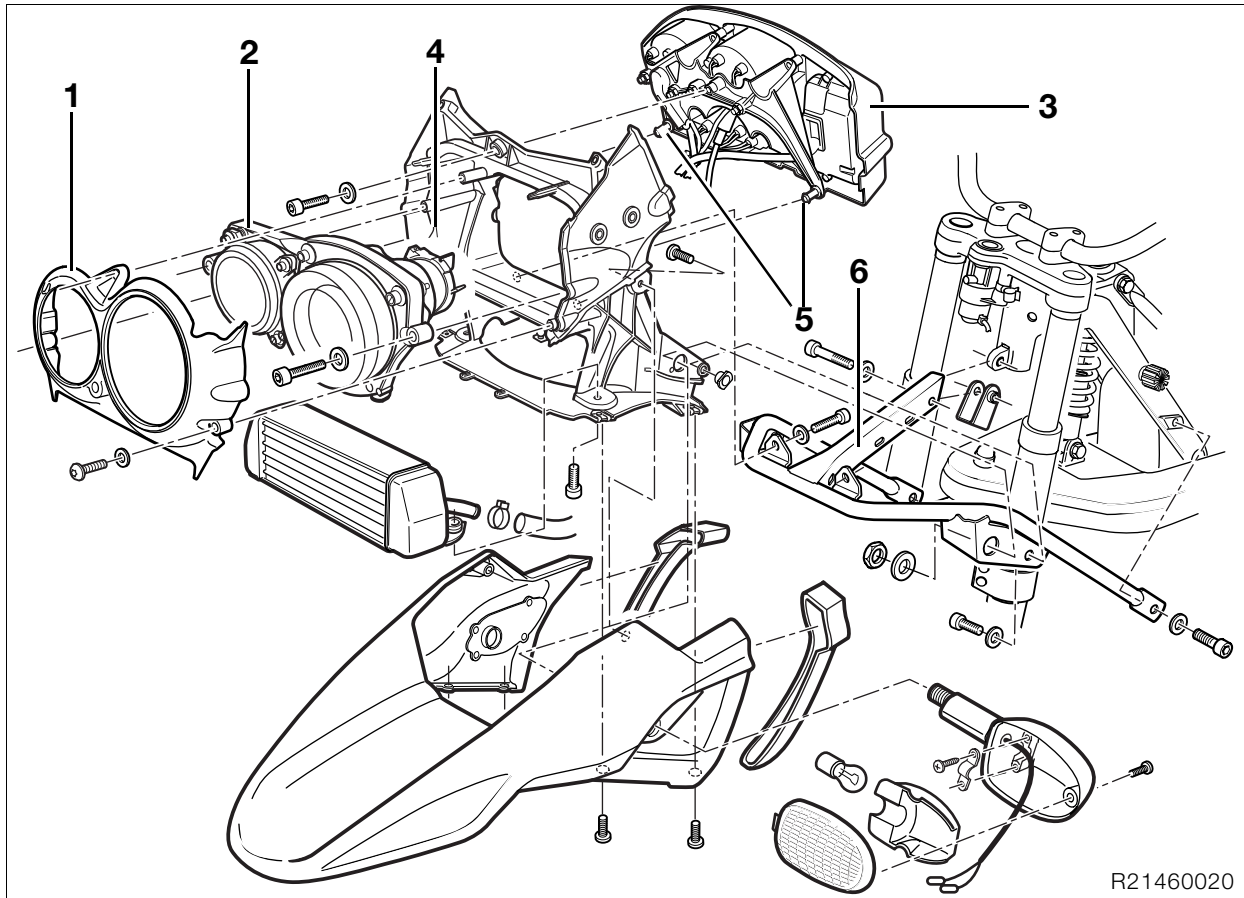

Removing and installing fairing bracket



Caution:

Switch off ignition.
Disconnect earth (ground) lead from battery.
Insulate earth (ground) lead.

- Remove fairing bracket (6).
- Installation is the reverse of the removal procedure.



Tightening torque:

Front mount to fairing bracket 8 Nm
Fairing bracket to frame 21 Nm
Horn to holder
(clean thread + Loctite 243)..... 10 Nm

- Remove the indicator lenses, disconnect plug and pull the cable through the indicator mount.
- Remove the turn indicators.
- Remove top section of mudguard.
- Remove windscreen.
- Remove top cover.
- Remove headlight glass (1).
- Remove headlight holder and disconnect plug.
- Remove headlight holder complete with headlight (2).
- Release instrument cluster (3) and pull it up until it is clear of the front mount.



Note:

Carefully pull thrust pad (5) on bracket of instrument carrier out of the front mount (4).

- Release left or right oil cooler line.
- Remove fasteners securing oil cooler and swing it aside; fix it in position with a cable tie if necessary.
- Remove the front mount.
- Release the wiring harness from fairing bracket (6).

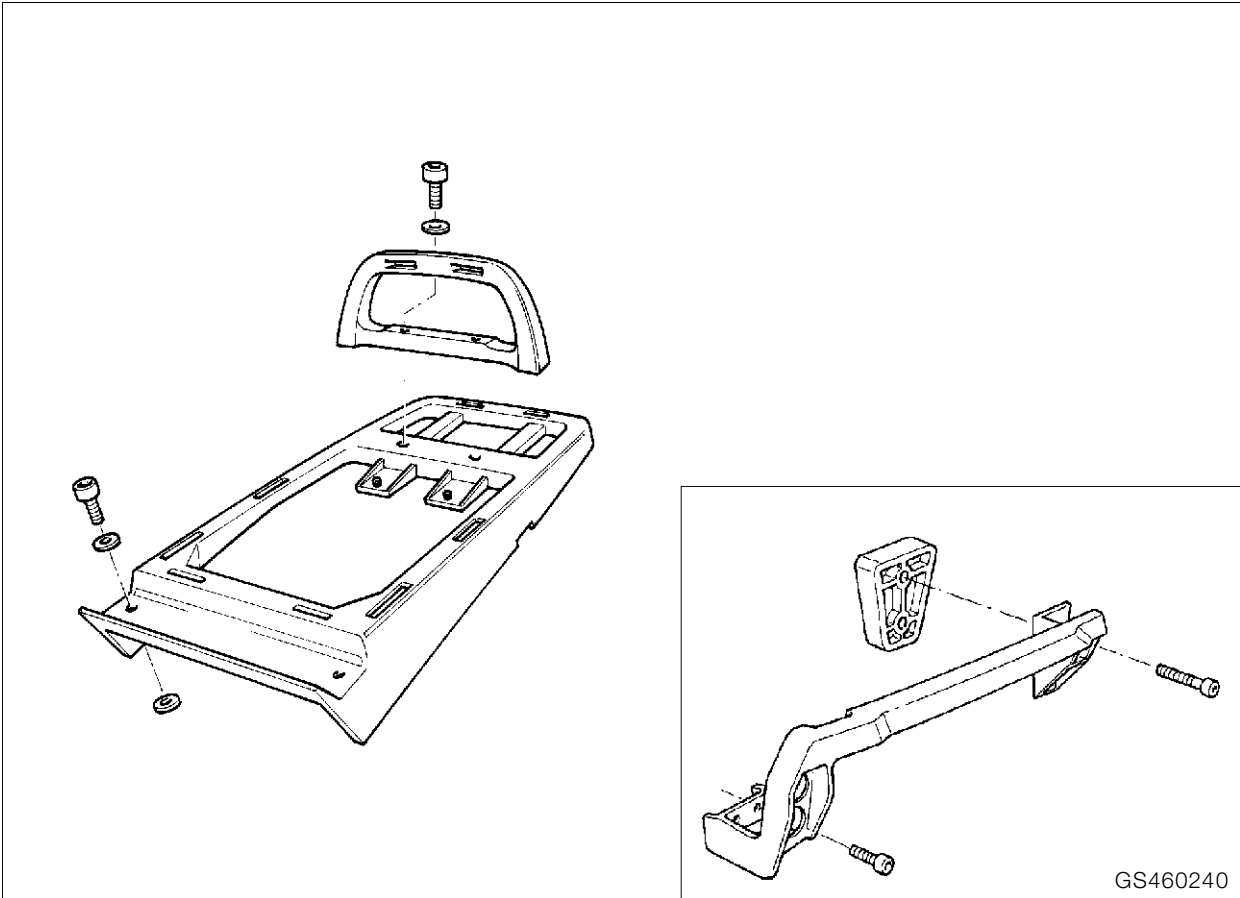

Removing and installing luggage rack

- Remove rear seat.
- Remove the toolkit.
- Remove the luggage rack.



Note:

The rear mudguard drops out of position; support it if necessary.

- Installation is the reverse of the removal procedure.

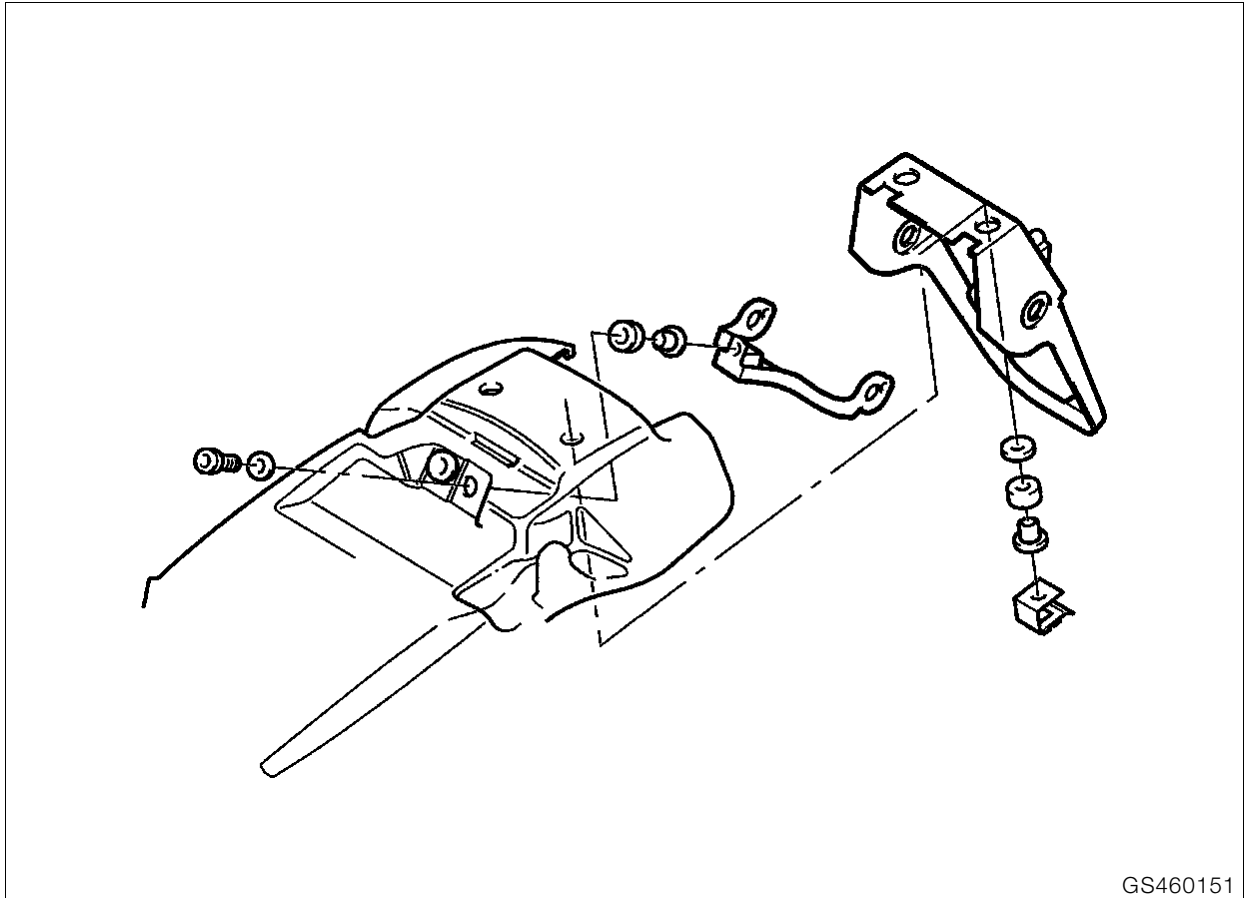

Removing and installing number-plate carrier



Caution:

Switch off ignition.
Disconnect earth (ground) lead from battery.
Insulate earth (ground) lead.

- Remove rear seat.
- Remove the toolkit box.
- Remove the tail light.
- Remove the turn indicators.
- Remove the number-plate carrier.
- Remove number plate bracket.
- Installation is the reverse of the removal procedure.

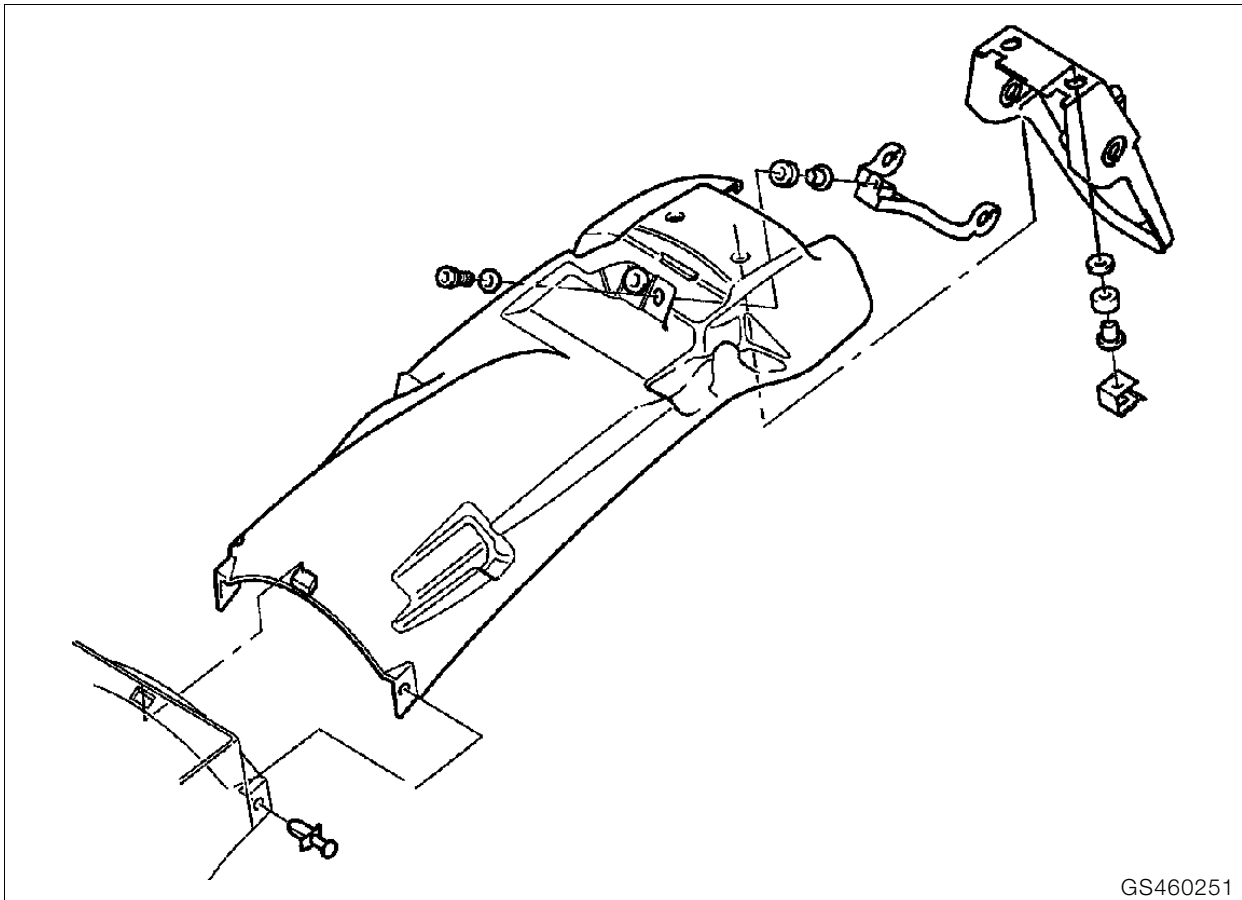

Removing/installing rear mudguard



Caution:

Switch off ignition.
Disconnect earth (ground) lead from battery.
Insulate earth (ground) lead.

- Remove the seat.
- Remove the toolkit box.
- Remove the tail light.
- Remove the turn indicators.
- Remove number plate bracket.
- Remove mudguard.
- Release the wiring harness from the tail section.
- Installation is the reverse of the removal procedure.

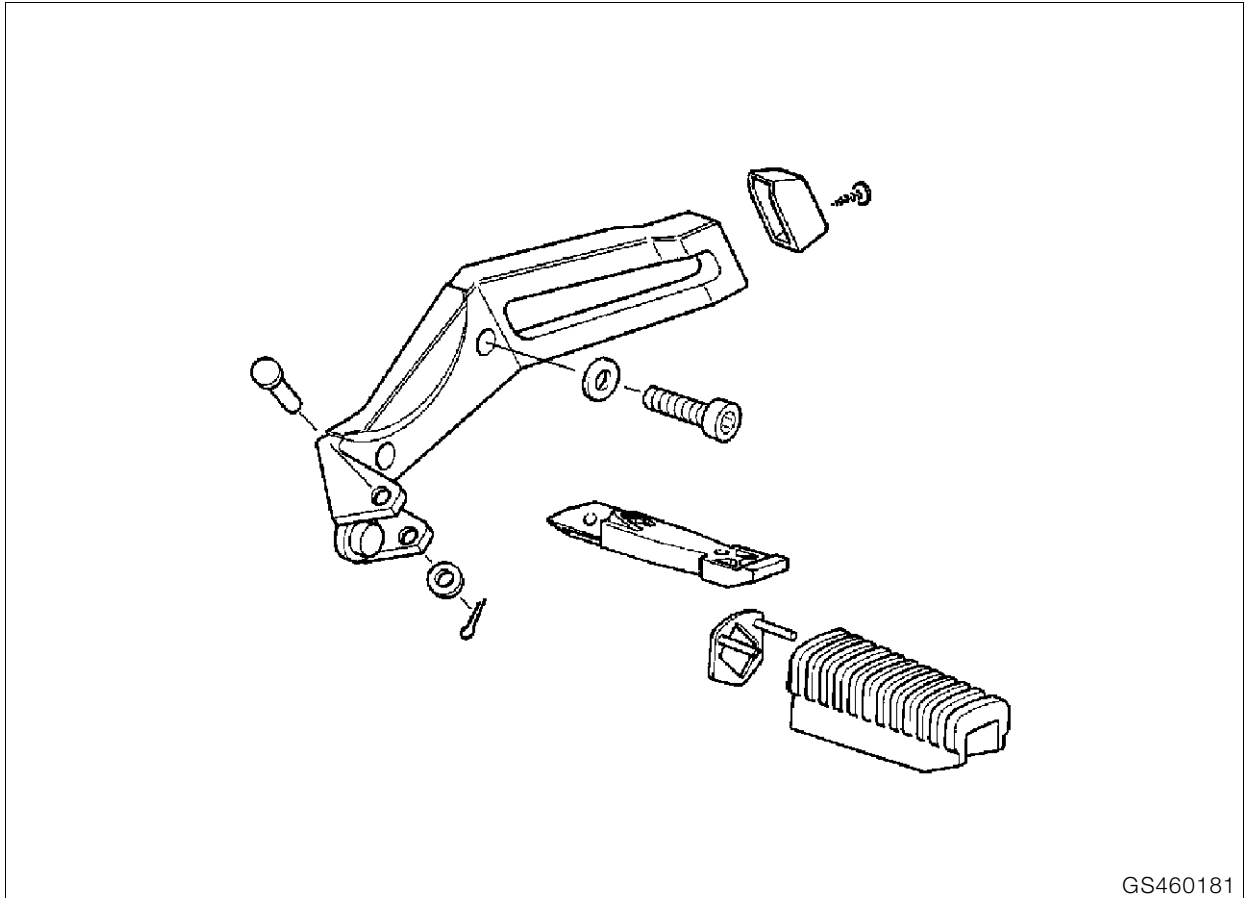

GS460181

Removing and installing rear footrest plate



Tightening torque:
Footrest plate to rear frame 21 Nm



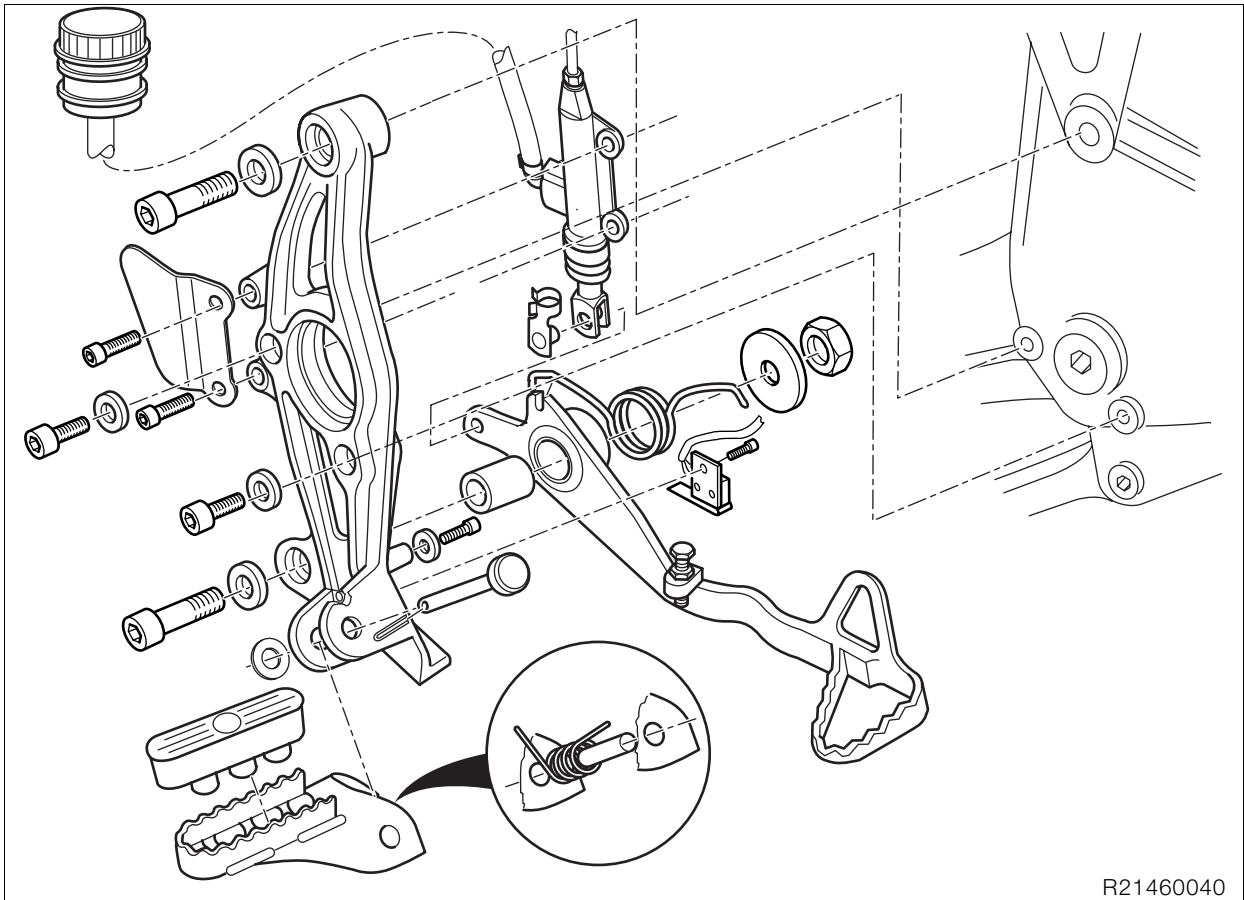

R21460040

Removing and installing front footrest plate

Removing and installing right footrest plate

- Remove brake pedal.
- Remove brake master cylinder.
- Remove the footrest plate.



! Tightening torque:

Footbrake lever to footrest plate	21 Nm
Footrest plate with rear frame to gearbox (clean thread + Loctite 243).....	42 Nm
Footrest plate to gearbox M 8	21 Nm

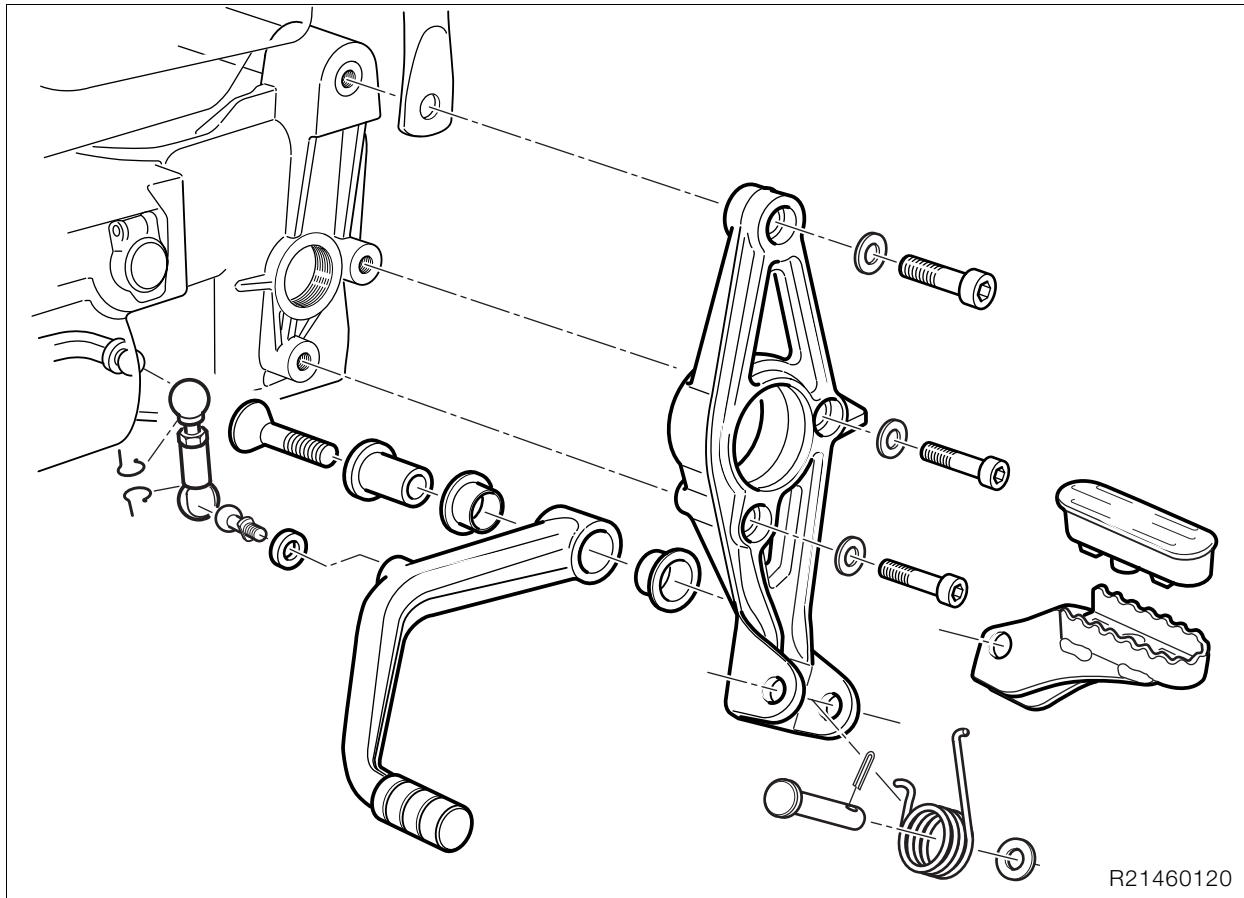

R21460120

Removing and installing left footrest plate

- Remove the shift lever.
- Remove hydraulic spring-strut adjuster.
- Remove the footrest plate.

 **Tightening torque:**

Shift lever to footrest plate	35 Nm
Footrest plate with rear frame to gearbox (clean thread + Loctite 243).....	42 Nm
Footrest plate to gearbox	21 Nm
Hydraulic spring-strut adjuster to footrest plate.....	22 Nm

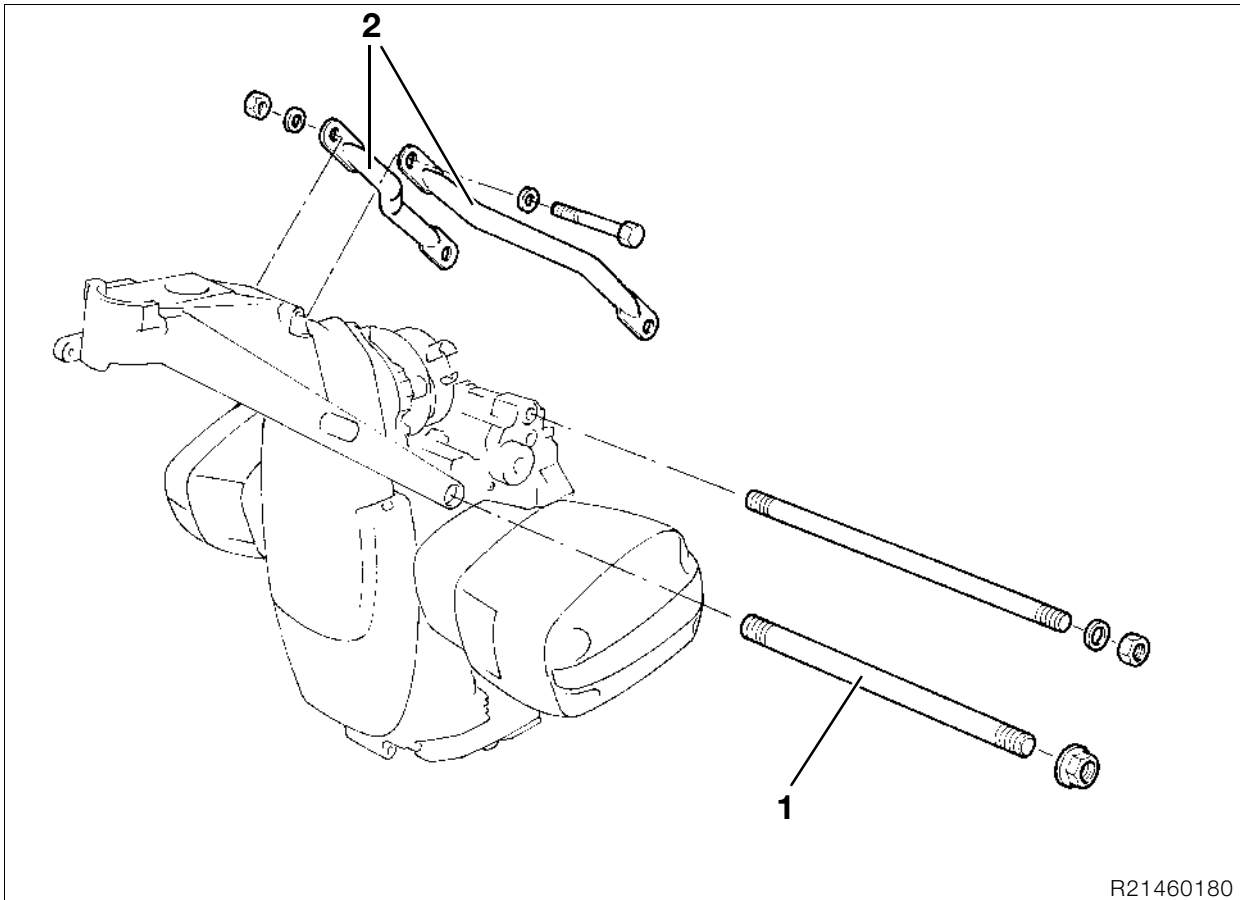

R21460180

Removing/installing frame

- Remove fuel tank.
- Release brake line from frame.
- Release cable from frame.
- Remove fasteners securing fairing bracket to frame.

Caution:

Hold the fairing securely so that it cannot fall. If necessary, use foam rubber or similar to support the fairing.

- Release the ball joint at the front of the leading link and pull the telescopic forks forward.
- Remove the fastener securing the front spring strut at the top.
- Remove engine bolt (1).

Caution:

If necessary, mask off the leading link to prevent it from being scratched.

- Hand-tighten the ball joint at the front of the leading link.
- Remove fasteners securing strut (2) to frame and slacken fasteners securing strut to engine.
- Remove fastener securing fork bridge to frame.



Note:

The screw pin is a press fit in the angular-contact ball bearing; remove as a complete unit.

- Remove frame.
- Installation is the reverse of the removal procedure.



Tightening torque:

Fork bridge to frame (clean thread + Loctite 243).....	130 Nm
Spring strut to frame	43 Nm
Frame to engine	82 Nm
Struts to frame	58 Nm
Struts to engine (clean thread + Loctite 2701).....	58 Nm
Fairing support bracket to frame	21 Nm

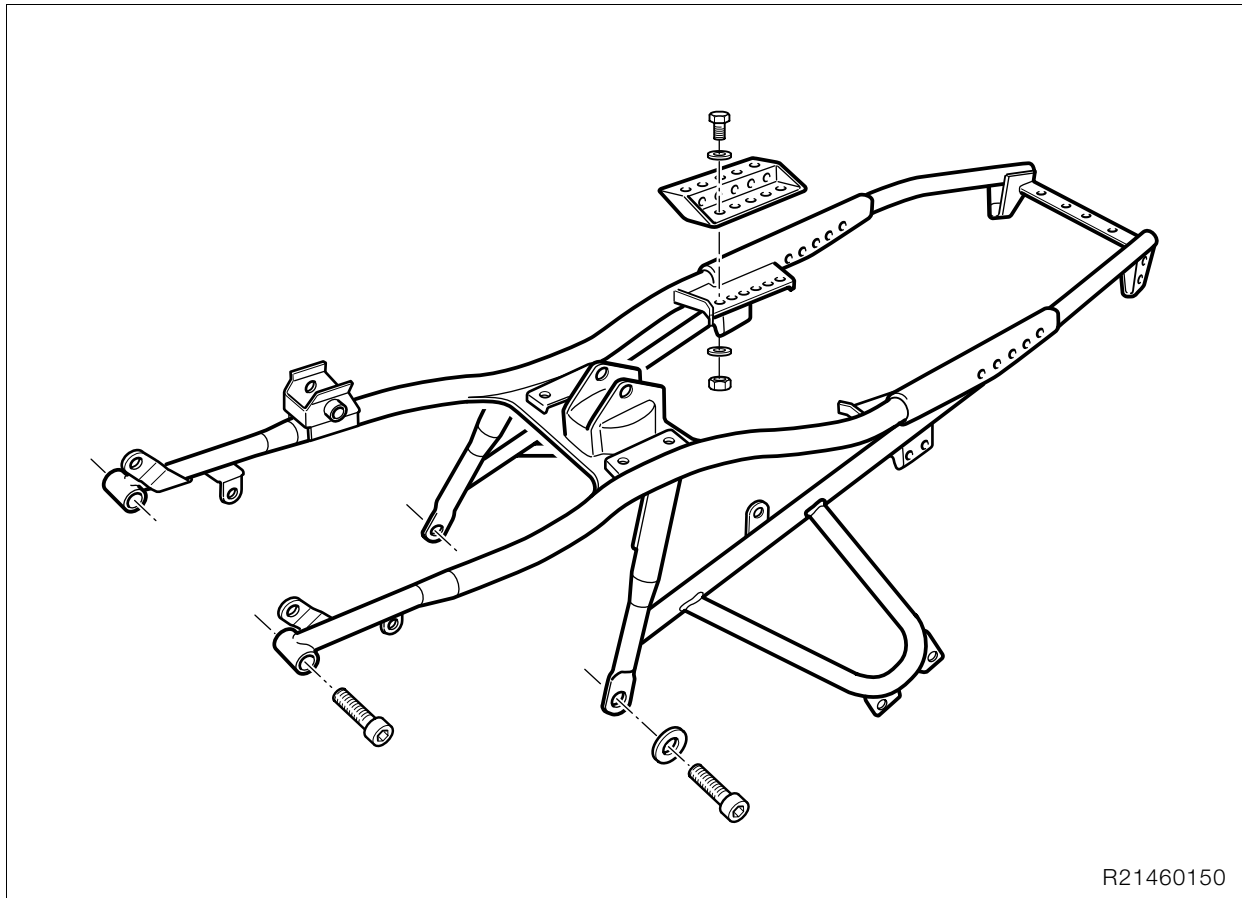

R21460150

Removing and installing frame tail section



Caution:

Switch off ignition.
 Disconnect earth (ground) lead from battery.
 Insulate earth (ground) lead.

- Remove the seat.
- Remove fuel tank.
- Remove luggage rack.
- Remove wiring harness from rear of frame/only loosen central electrical equipment box.
- **[ABS]** Disconnect plug of ABS sensor and cable.
- Disconnect the brake light switch plug and detach the cable.
- Disconnect the side stand switch plug and detach the cable.
- Disconnect the idle switch plug and detach the cable.
- Disconnect the diagnostic plug and detach the cable.
- Remove holder of brake line.
- Remove brake fluid reservoir from its holder.
- Remove the silencer from the rear frame section.
- Remove upper fastener of spring strut.
- Remove the air filter box from the rear frame section.

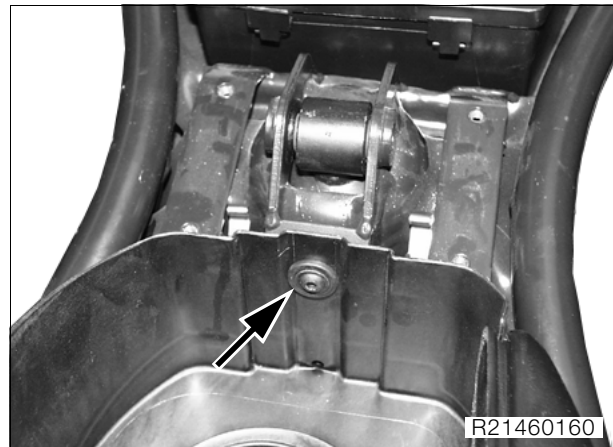

R21460160

- Remove fastener of rear frame section in air filter box (arrow).
- Remove rear section of frame.
- Remove fittings.
- Installation is the reverse of the removal procedure.



Tightening torque:

Frame to gearbox and footrest plate (clean thread + Loctite 243).....	42 Nm
Frame to engine	42 Nm

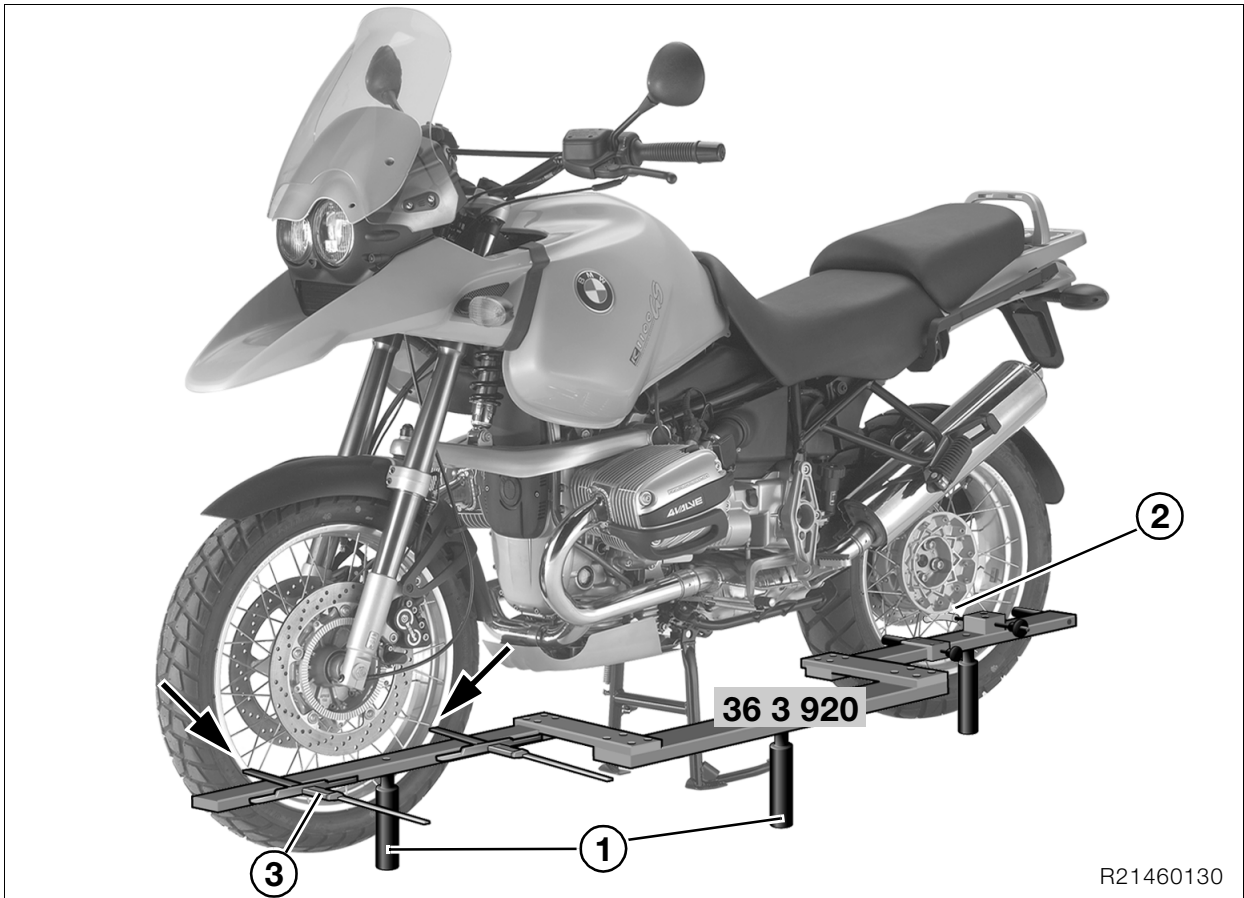

R21460130

Checking running gear

Measuring wheel track offset

- Place the motorcycle on its main (centre) stand on a flat, level surface.
- Place the track offset gauge, **BMW No. 36 3 920**, against the left or right side of the motorcycle.



Note:

In order to use the track alignment gauge on either the left or right side, simply screw the supports in on the other side.

- Adjust support (1) so that the measuring plane is as close as possible to the wheel centreline. The gauge must slide freely up to the motorcycle.
- Position the measuring stops (arrows) so that they touch the wheel rim and not the tyre.
- Attach hook (2) to wheel spoke to secure the gauge firmly to the wheel.
- Align front wheel parallel with the gauge.
- Measure distance between outer edge of gauge and wheel rim, using depth gauge (3) or ruler, and make a note of the distance.

- Calculate wheel track offset “S”:
- Wheel track offset “S” is the distance to left or right between the longitudinal axes of the front and rear wheels.

Track offset (S):+ 3 mm (0.12 in) (= to right)

Permissible wheel track offset (S):
± 9 mm (0.35 in); datum is + 4.5 mm (0.18 in)



Note:

Key to measurement result:

Negative sign = wheel track offset to left
 Positive sign = wheel track offset to right

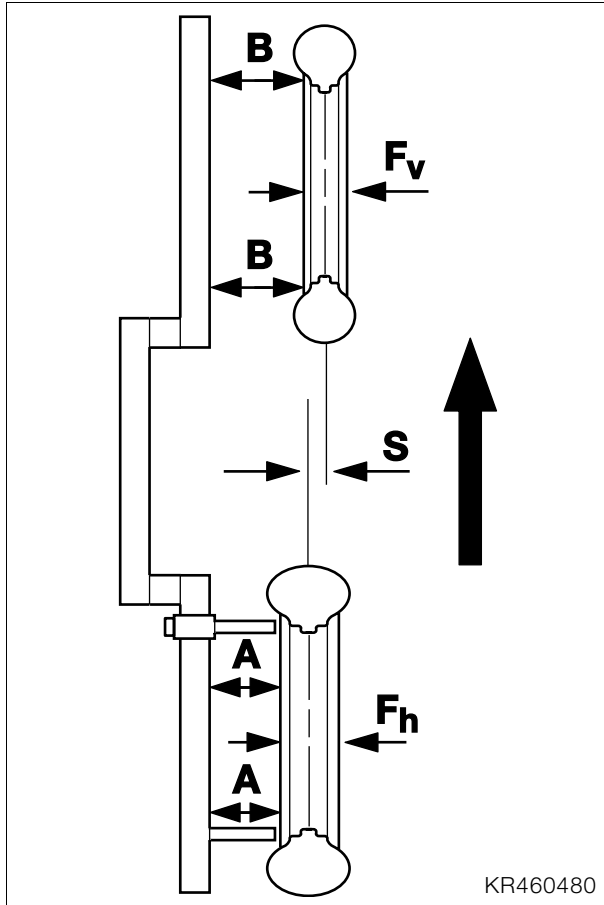

EXAMPLE:

Formula $S = A + \frac{F_h}{2} - \left(B + \frac{F_v}{2} \right)$

Fixed value “A”
 (length of measuring stops)

$A = 50.0 \text{ mm (1.97 in)}$

Half of rear wheel rim width

$\frac{F_v}{2} = 66.3 \text{ mm (2.61 in)}$

$A + \frac{F_h}{2} = 116.3 \text{ mm (4.58 in)}$

Measured value (B)+

$B = 70.0 \text{ mm (2.76 in)}$

Half of front wheel rim width

$\frac{F_v}{2} = 47.5 \text{ mm (1.87 in)}$

$B + \frac{F_v}{2} = 117.5 \text{ mm (4.63 in)}$

Track offset “S”

$S = A + \frac{F_h}{2} - \left(B + \frac{F_v}{2} \right)$

$S = 116.3 \text{ mm} - 117.5 \text{ mm (4.58 in - 4.63 in)}$

Track offset “S” = - 1.2 mm (- 0.05 in)



Measuring the leading link

– Remove leading link

➡See Group 31

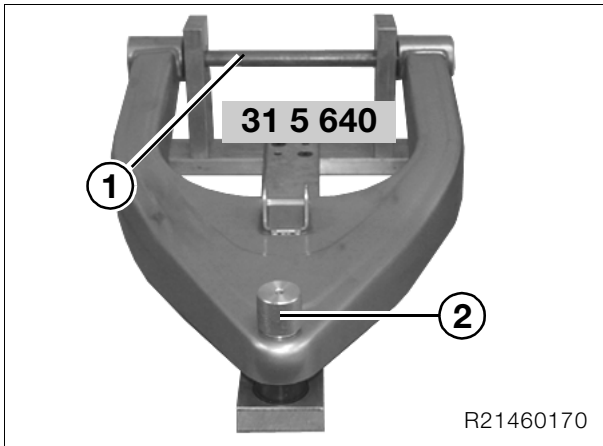

- Secure the leading link with shaft (1) to leading link gauge, **BMW No. 31 5 640**.
- Tighten the shaft until the leading link is located in the gauge with no axial play.



Note:

Shaft (1) must slide into the leading link without resistance.
Check runout of shaft (1).

- Insert test mandrel (2) all the way into the bore.



Note:

Check the leading link for signs of the paint flaking.

Interpreting result of measurement:

Test mandrel slides all the way into the bore without resistance

.....OK

Test mandrel sticks, force is required to slide it into the bore or it cannot be inserted

..... Replace leading link

– Install leading link

➡See Group 31

51 Equipment

Contents

Page

Removing and installing ignition switch/steering lock	3
Removing and installing ignition/light switch	3
Removing and installing lock barrel	3
Drilling out lock barrel	3
Removing and installing lock barrel for fuel tank filler cap	4
Drilling out lock barrel	4
Removing and installing seat lock	5
Removing and installing lock barrel	5
Removing and installing helmet lock	5



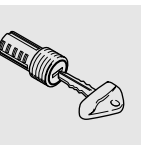

Removing and installing ignition switch/steering lock

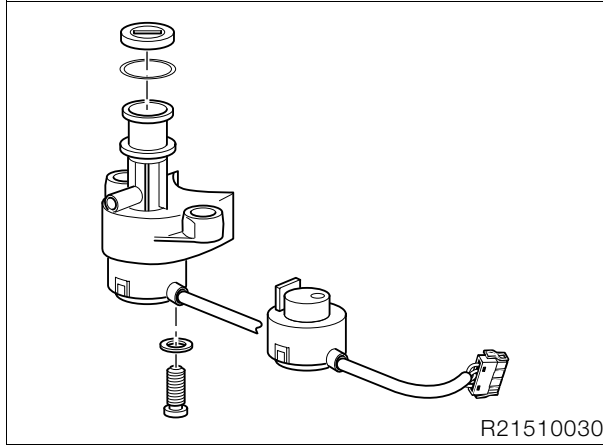

- Remove fork bridge.
- With a 4 mm (0.16 in) dia. drill bit, drill approx. 5 mm (0.20 in) into non-removable screw (1).
- Use an 8 mm (0.31 in) dia. drill bit to drill away the screw head.
- Pull out the ignition switch/steering lock.
- Unscrew and remove remainder of screw with stud bolt extractor.
- Install steering lock with non-removable socket wrench insert, **BMW No. 51 0 531**.



Tightening torque:

Non-removable screws
(micro-encapsulated)..... 20 Nm

Removing and installing ignition/light switch

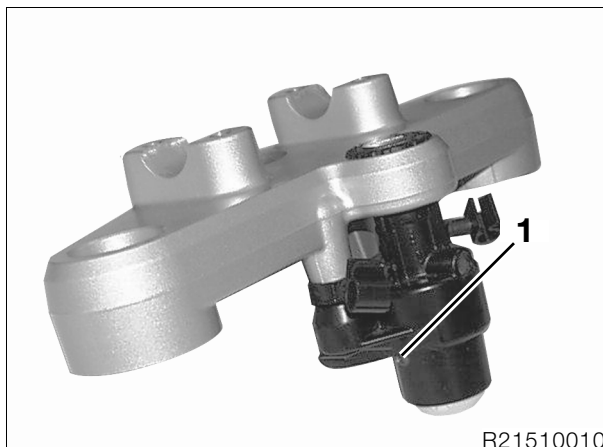

- Remove screw (1).
- Remove the ignition/light switch.
- Installation is the reverse of the removal procedure.

Removing and installing lock barrel

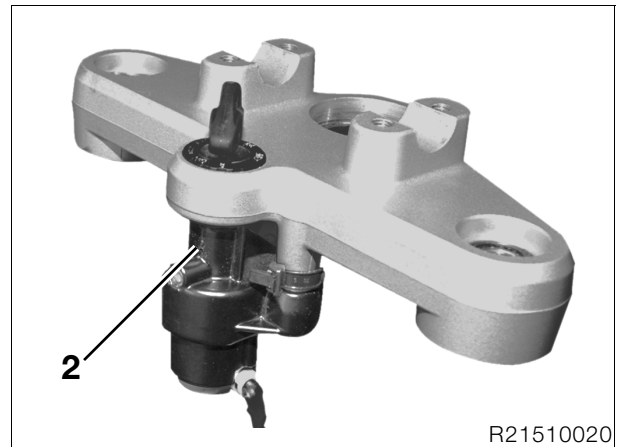

- Key in ON position/press in keeper (2) with a stiff wire or similar.
- Pull out lock barrel with key.
- Lubricate the new lock barrel with **Shell Retinax A**.
- Insert the lock barrel with the key in the ON position.
- Press lock barrel down until keeper engages.

Drilling out lock barrel

- Use a 4-5 mm (0.16-0.20 in) dia. drill bit to drill the full length of the lock barrel.
- Repeat with a drill bit of larger diameter until the lock barrel can be removed.



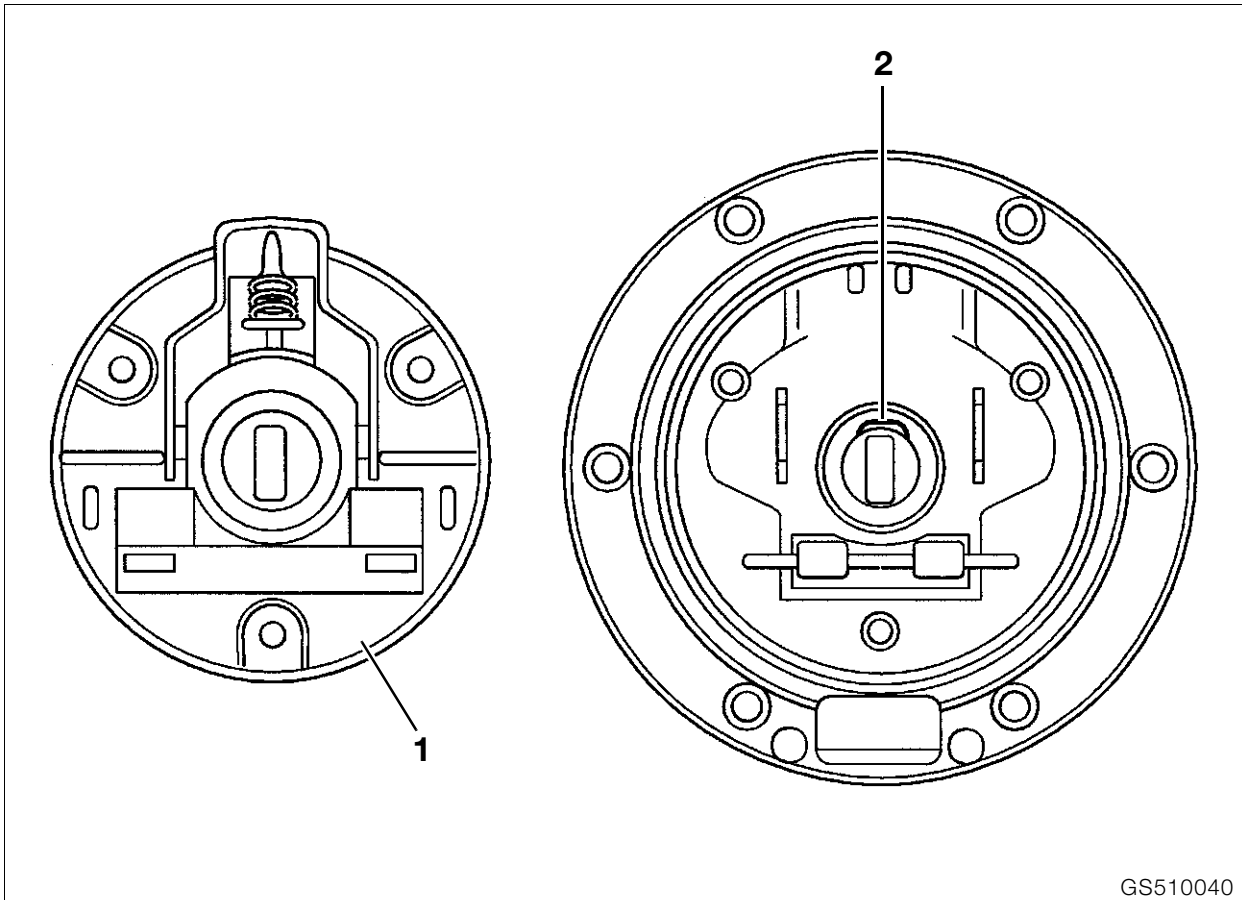

GS510040

Removing and installing lock barrel for fuel tank filler cap



Note:

Make sure that screws do not fall into fuel tank: cover fuel tank filler neck with cloth.

- Open cap and remove lower part of cap (1).
- Insert key in lock barrel and press down on retainer (2).
- Pull out lock barrel with key.
- Lubricate the new lock barrel with **Shell Retinax A**.
- Install lock barrel with key (at a right angle to direction of travel).
- Installation is the reverse of the removal procedure.

Drilling out lock barrel

- Use a 4-5 mm (0.16-0.20 in) dia. drill bit to drill the full length of the lock barrel.
- Repeat with a drill bit of larger diameter until the lock barrel can be removed.

Removing and installing seat lock

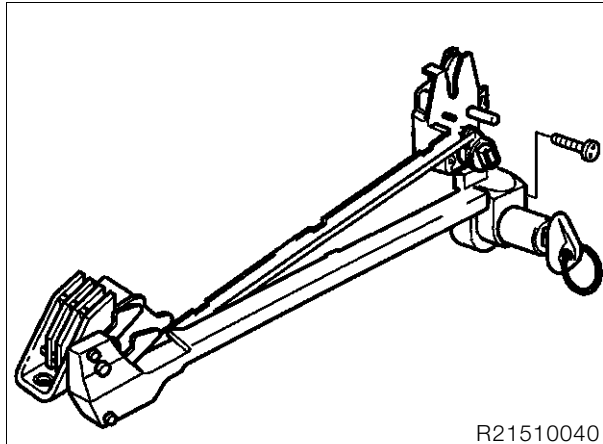

R21510040

Removing and installing helmet lock

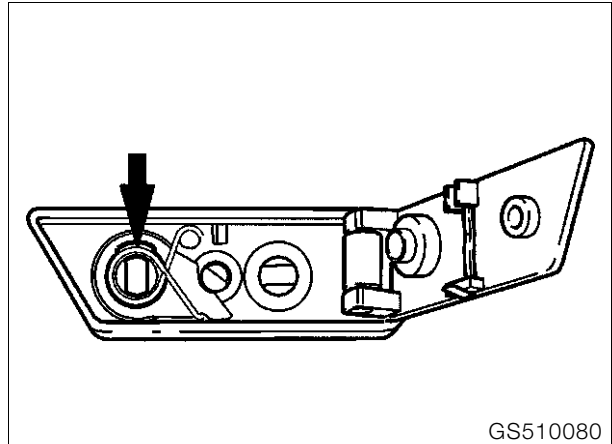

GS510080

Removing and installing lock barrel

- Remove luggage rack.
- Remove seat lock.
- Disassemble seat lock on key side (2 screws) and carefully spread it open.

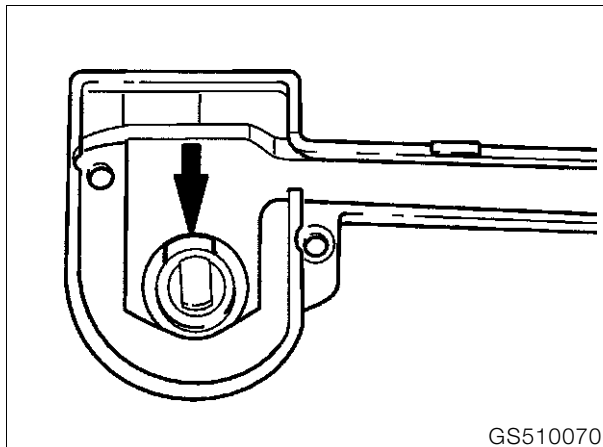

GS510070

- Press the keeper (arrow) of the lock barrel into the housing and use the key to pull out the barrel.
- Lubricate the new lock barrel with **Shell Retinax A**.
- Press lock barrel in until keeper engages.
- Installation is the reverse of the removal procedure.

- Open the retainer.
- Remove the helmet lock.
- Use a screwdriver to pry off the cap on the inside.
- Remove the spring and the hook.
- Press the keeper of the lock barrel into the housing and use the key to pull out the barrel.
- Lubricate the new lock barrel with **Shell Retinax A**.
- Press lock barrel in until keeper engages.
- Installation is the reverse of the removal procedure.



52 Seat

Contents

Page

Disassembling/assembling seat3





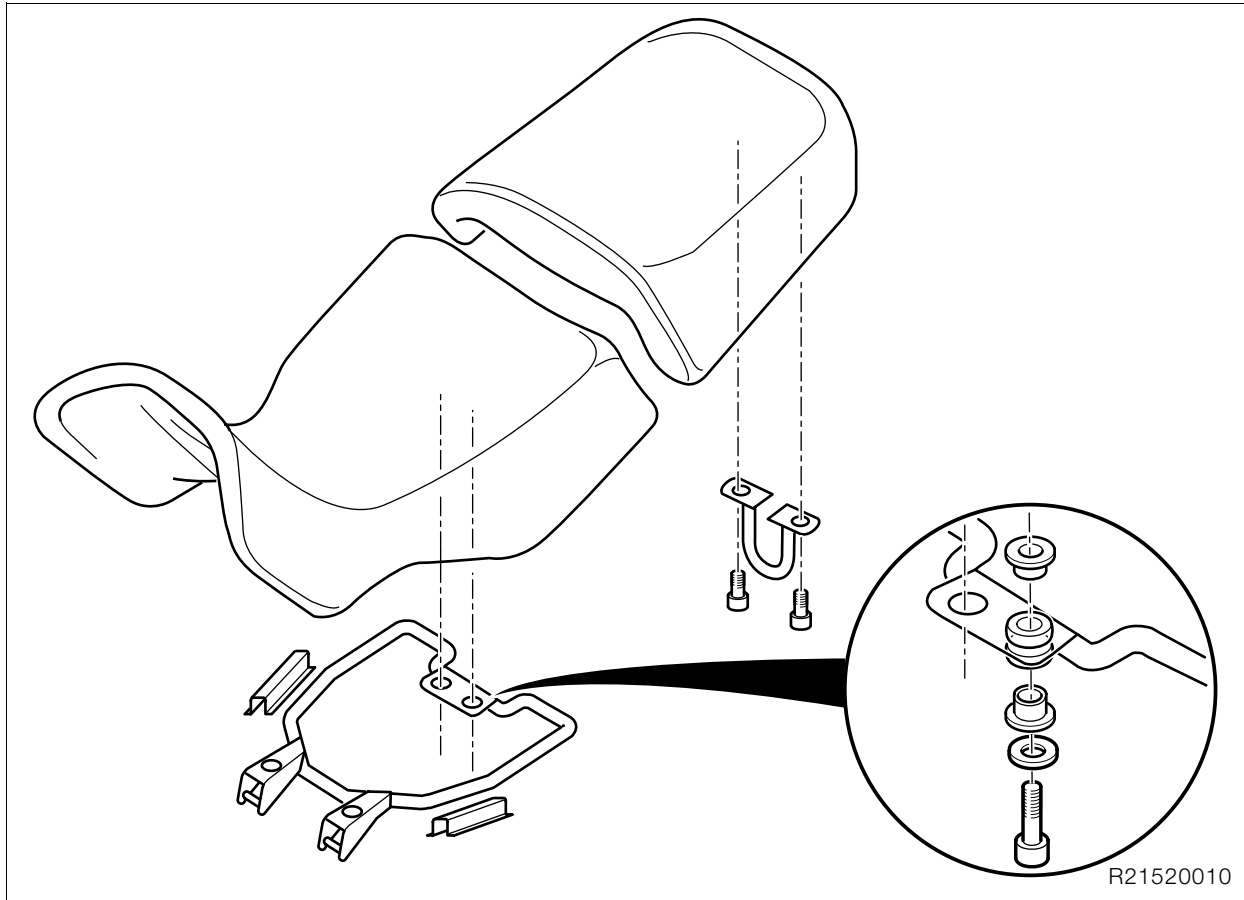

Disassembling/assembling seat

61 General electrical equipment

Contents	Page
Technical Data	3
Removing and installing central electrical equipment box	5
Disassembling/assembling central electrical equipment box	5
Relay positions/fuse assignments (central electrical equipment box)	6
Fuse assignments	6
Wiring-harness routing, frame	
[ABS]	7
Wiring-harness routing/connection in central electrical equipment box	8
Wiring-harness routing/central electrical equipment box/output	9
Wiring-harness routing	
View from left	10
Wiring-harness routing	
View from right	13
Removing and installing battery holder	17



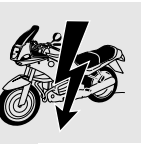

Technical Data		R 1150 GS
Battery	A/h	14
	A/h	Option: 19



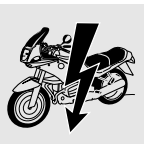

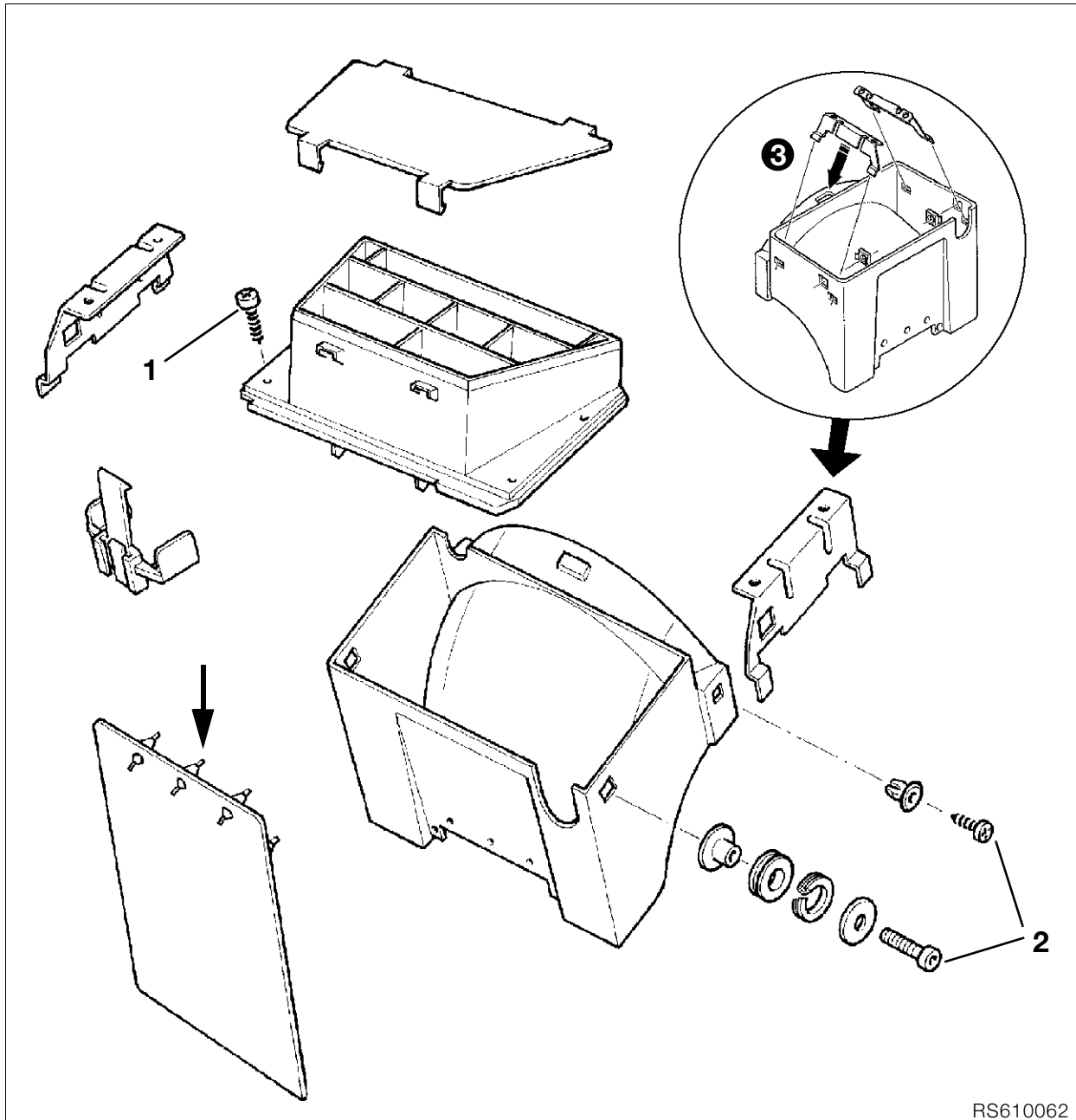

RS610062

Removing and installing central electrical equipment box



Caution:

Switch off ignition.
Disconnect earth (ground) lead from battery.
Insulate earth (ground) lead.

- Remove the seat.
- Remove screws (1) securing top of central electrical equipment box.
- Remove screws (2) securing bottom of central electrical equipment box.
- Pull cable tray down and remove.
- Remove relay and relay base or if necessary, disconnect entire wiring harness and remove complete with fuse box.
- Installation is the reverse of the removal procedure.

- After installation, shorten the middle rubber lug of the anti-spray fastener (arrow) to 10 mm (0.3937 in).
- Switch on the ignition.
- Without starting the engine, fully open the throttle once or twice so that the Motronic control unit can register the throttle-valve positions.



Note:

Disconnecting the battery deletes all entries (e.g. faults, settings) stored in the Motronic control unit's memory.
Loss of settings can temporarily impair the operating characteristics when the engine is restarted.

Disassembling/assembling central electrical equipment box

- See illustration (3).



Relay positions/fuse assignments (central electrical equipment box)

Relay positions

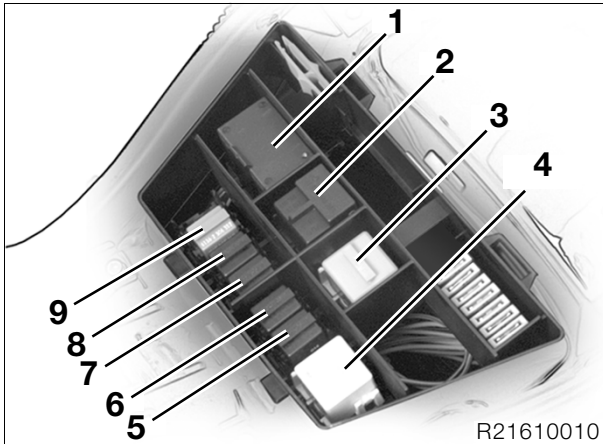

1. Flasher unit
2. Indicator damping
3. Coded plug for Motronic
4. Starter motor relay
5. Relief relay
6. Horn relay
7. Fuel pump relay
8. Motronic relay
9. ABS warning relay

Fuse assignments

(No. 1 on left, looking forwards)

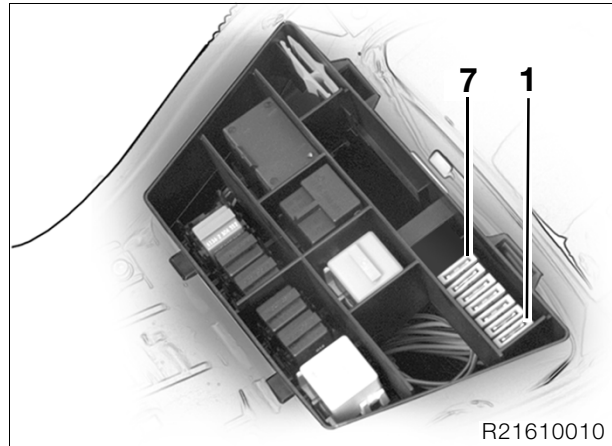

1. Instrument cluster, indicator damping,
brake light 4 A
2. Parking light, tail light 4 A
3. RID, power socket 15 A
4. Horn 7.5 A
5. Motronic, diagnostic plug 10 A
6. Fuel pump 10 A
7. Heated handlebar grips 4 A



Wiring-harness routing, frame [ABS]



Caution:

Use (yellow) galvanized screws for the ground (earth) connection to the engine. Screws with unsuitable corrosion proofing can cause the electrical resistance to rise as high as 80 Ω . Run wiring without kinking and avoid risk of abrasion. Note the number and position of the cable ties.

- Apply a thin coating of contact grease, e.g. **CENTOPLEX 3 CU** to the central earth (ground) point, which must be cleaned to bright metal first.



Note:

When removing the wiring harness, take out the central electrical equipment box at the same time. When installing, install the central electrical equipment box first.



Tightening torque:

Ground (earth) connection to engine 9 Nm



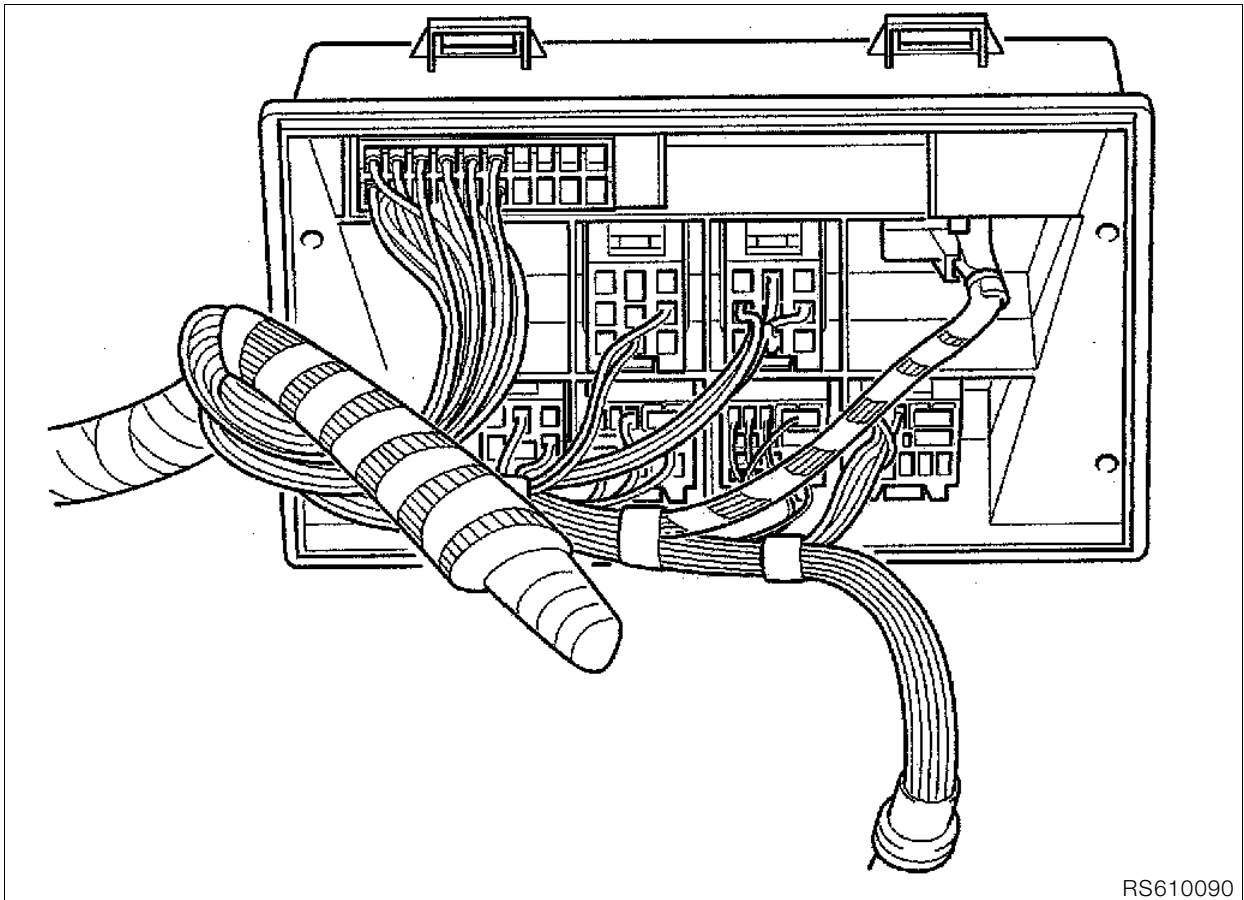

RS610090

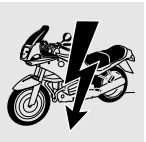

Wiring-harness routing/connection in central electrical equipment box

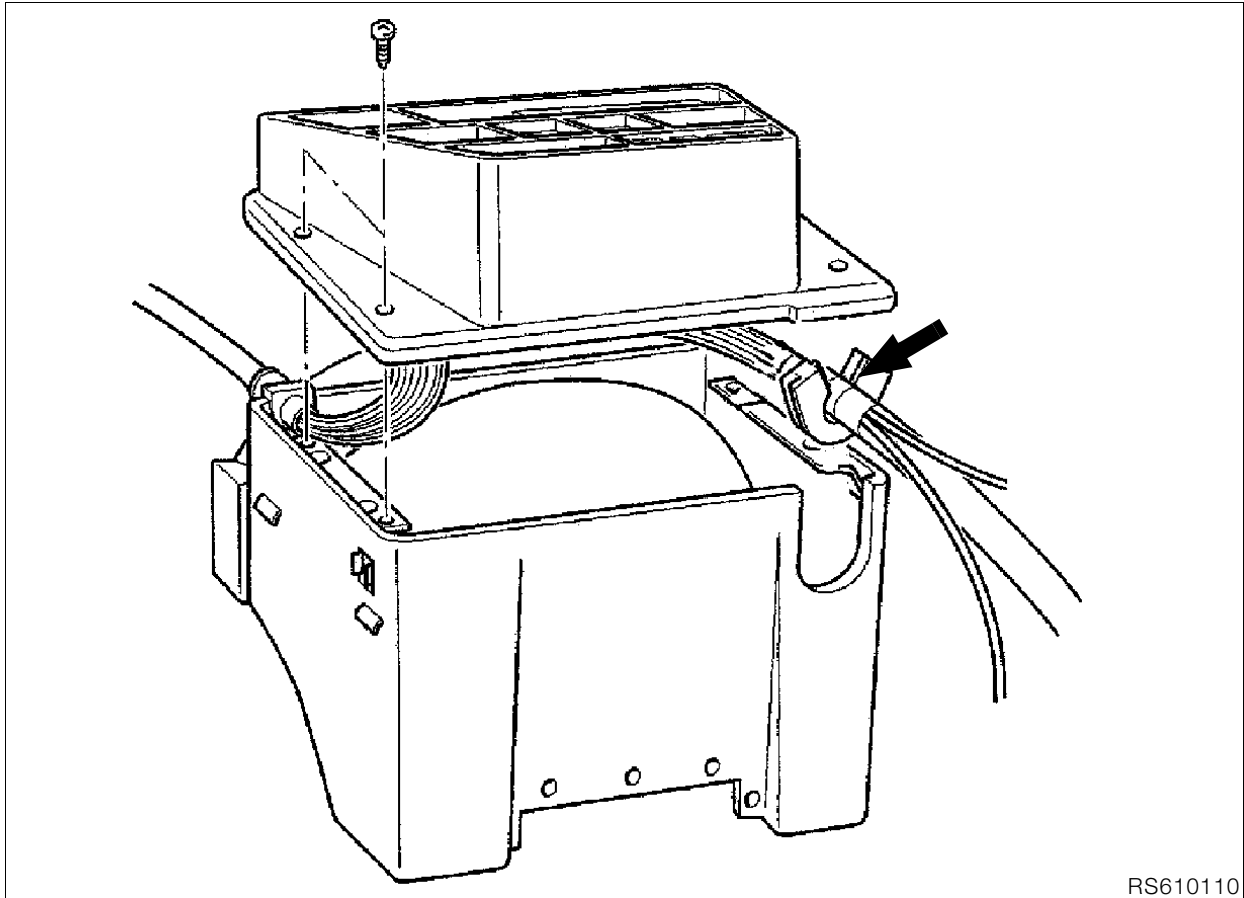

Wiring-harness routing/central electrical equipment box/output



Note:

The white mark (arrow) must be covered by the grommet.



Wiring-harness routing
View from left

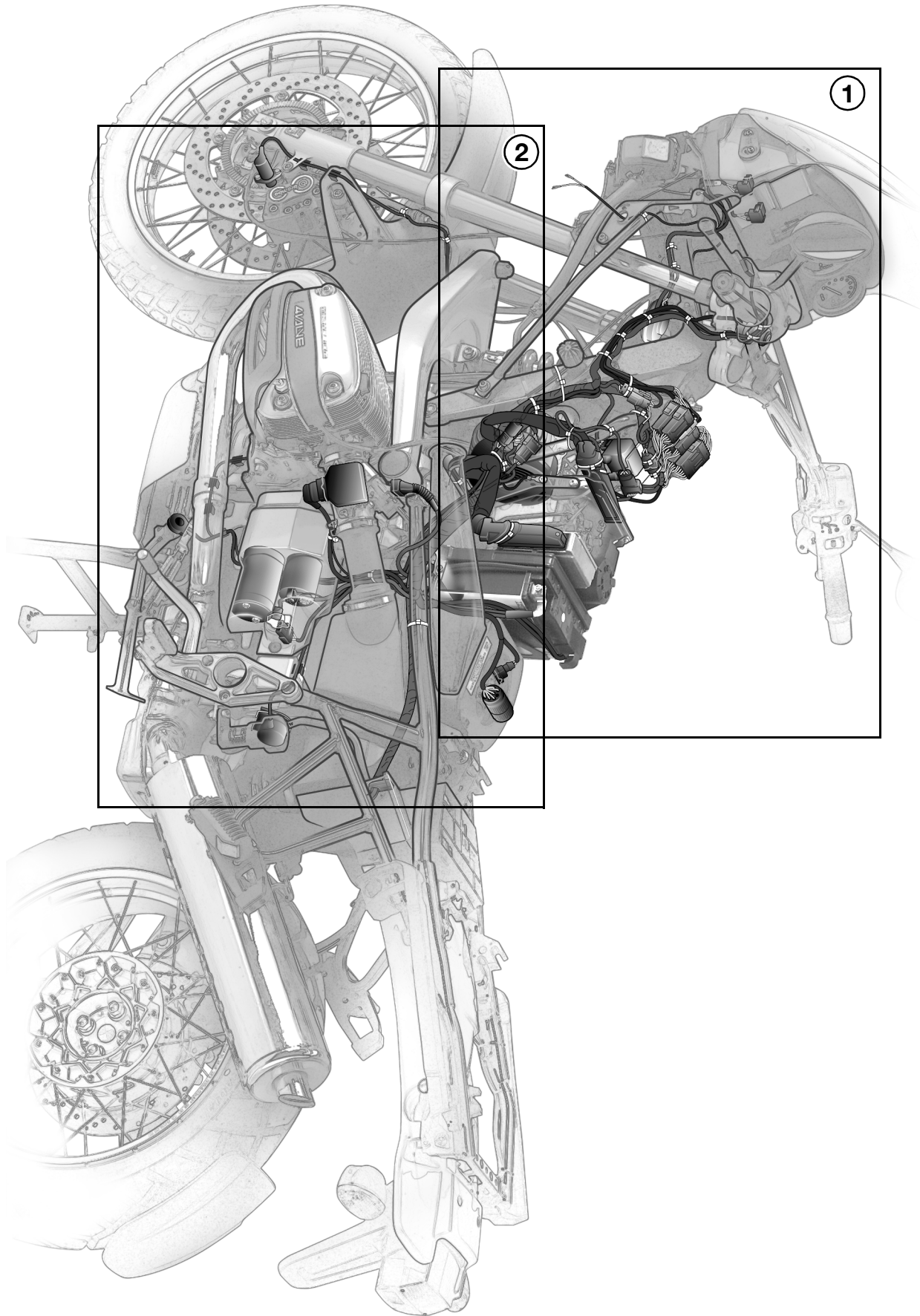

R21619010

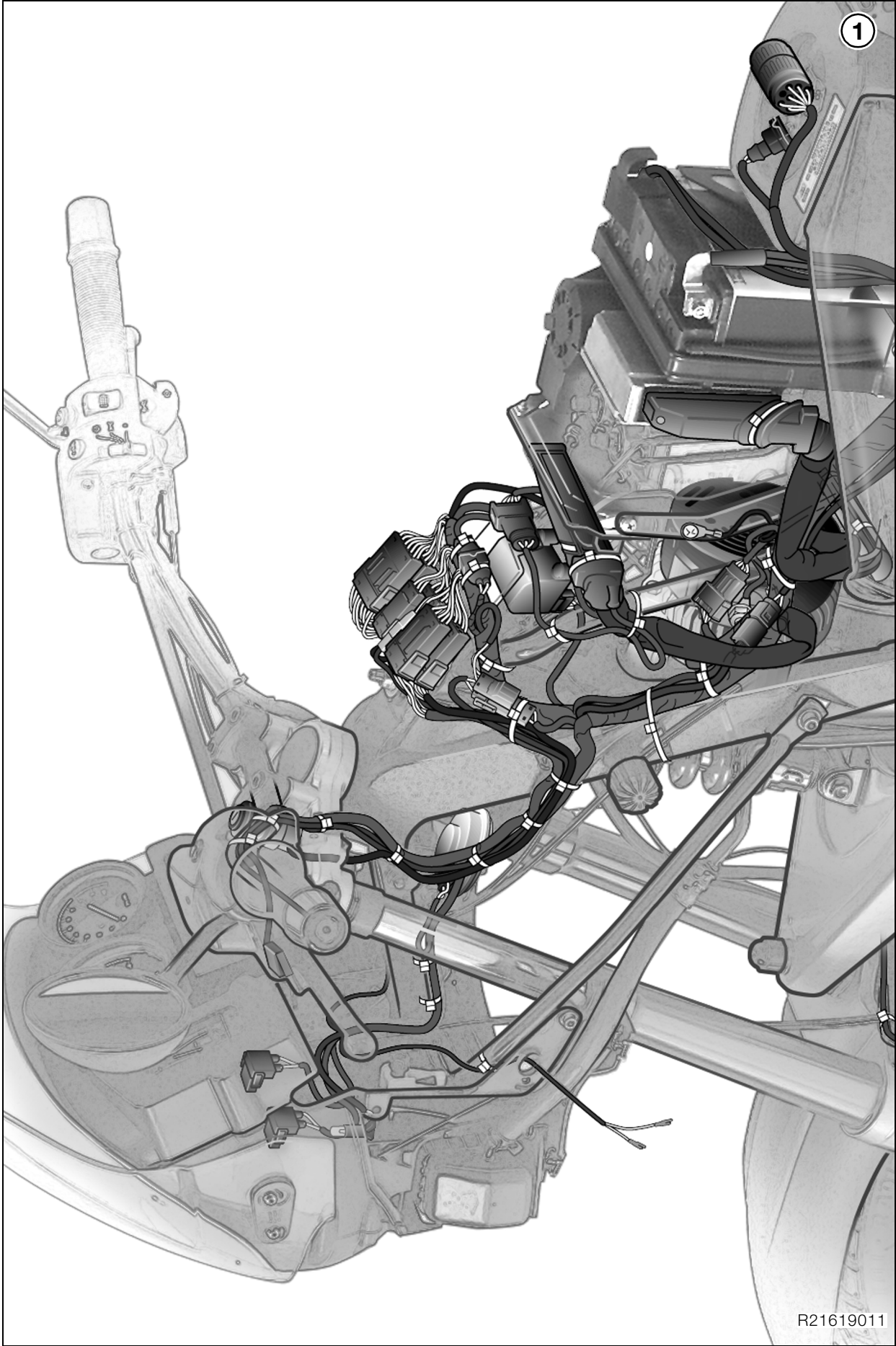

R21619011

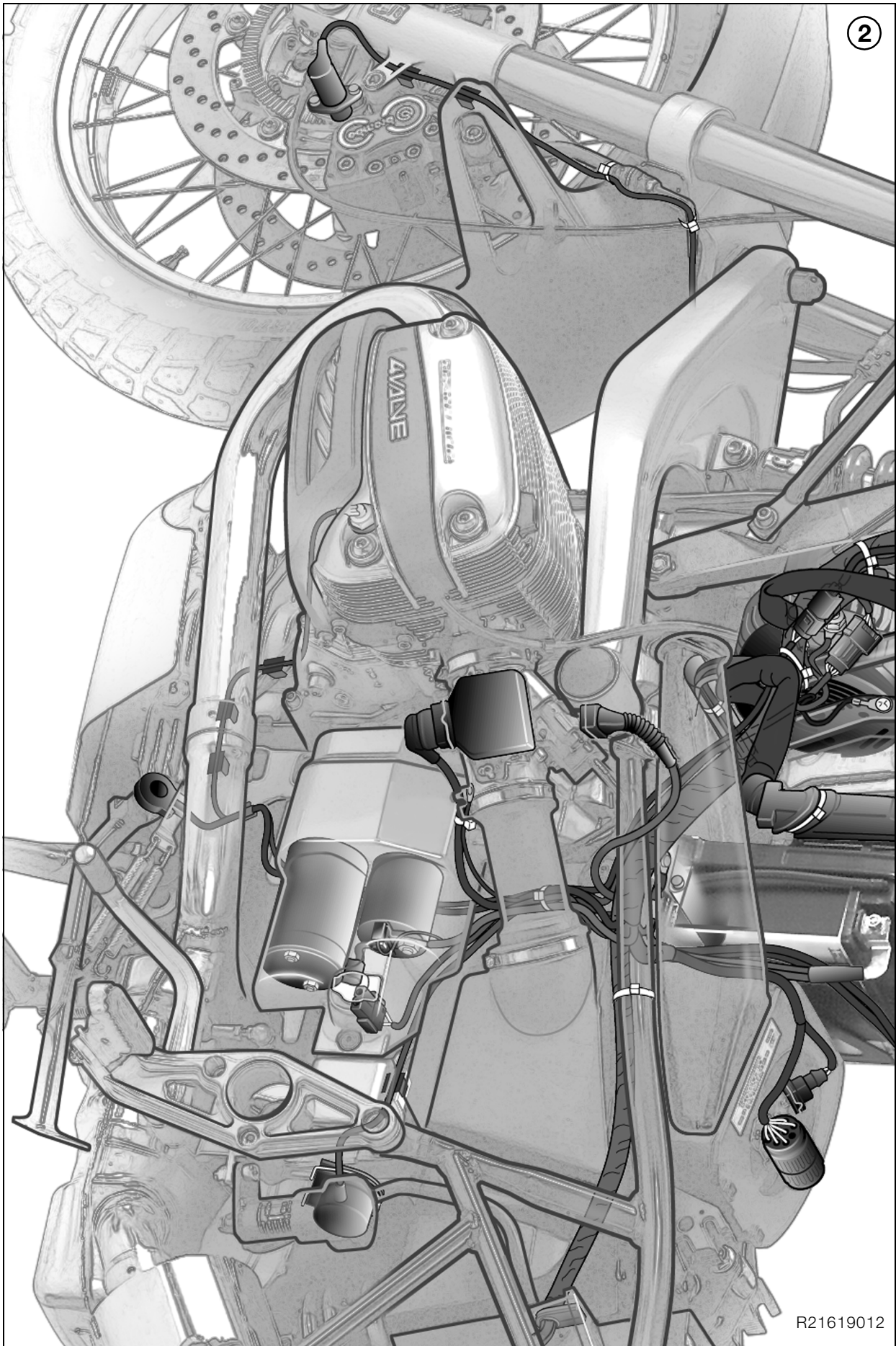

R21619012

Wiring-harness routing
View from right

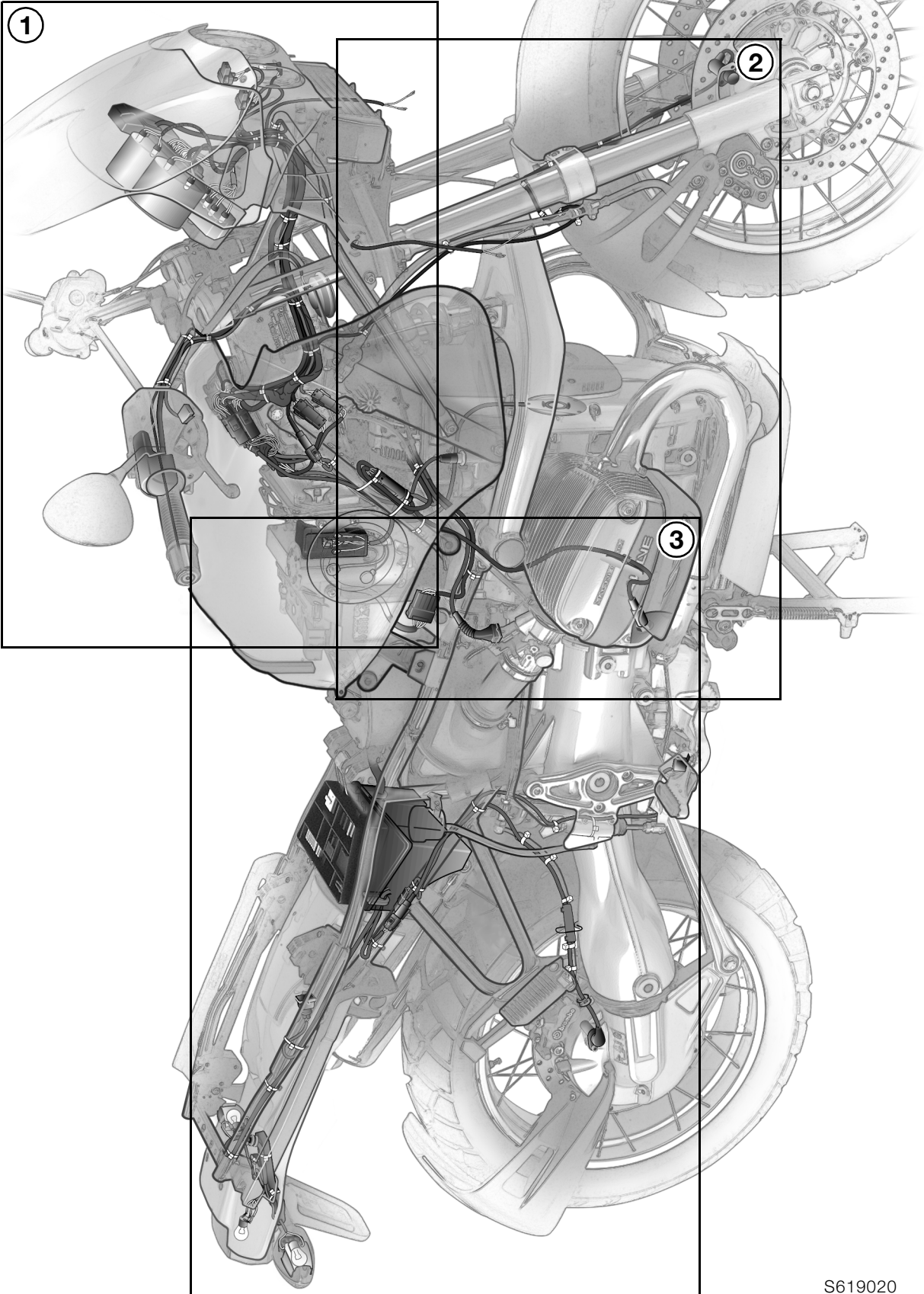

S619020

1



R21619021



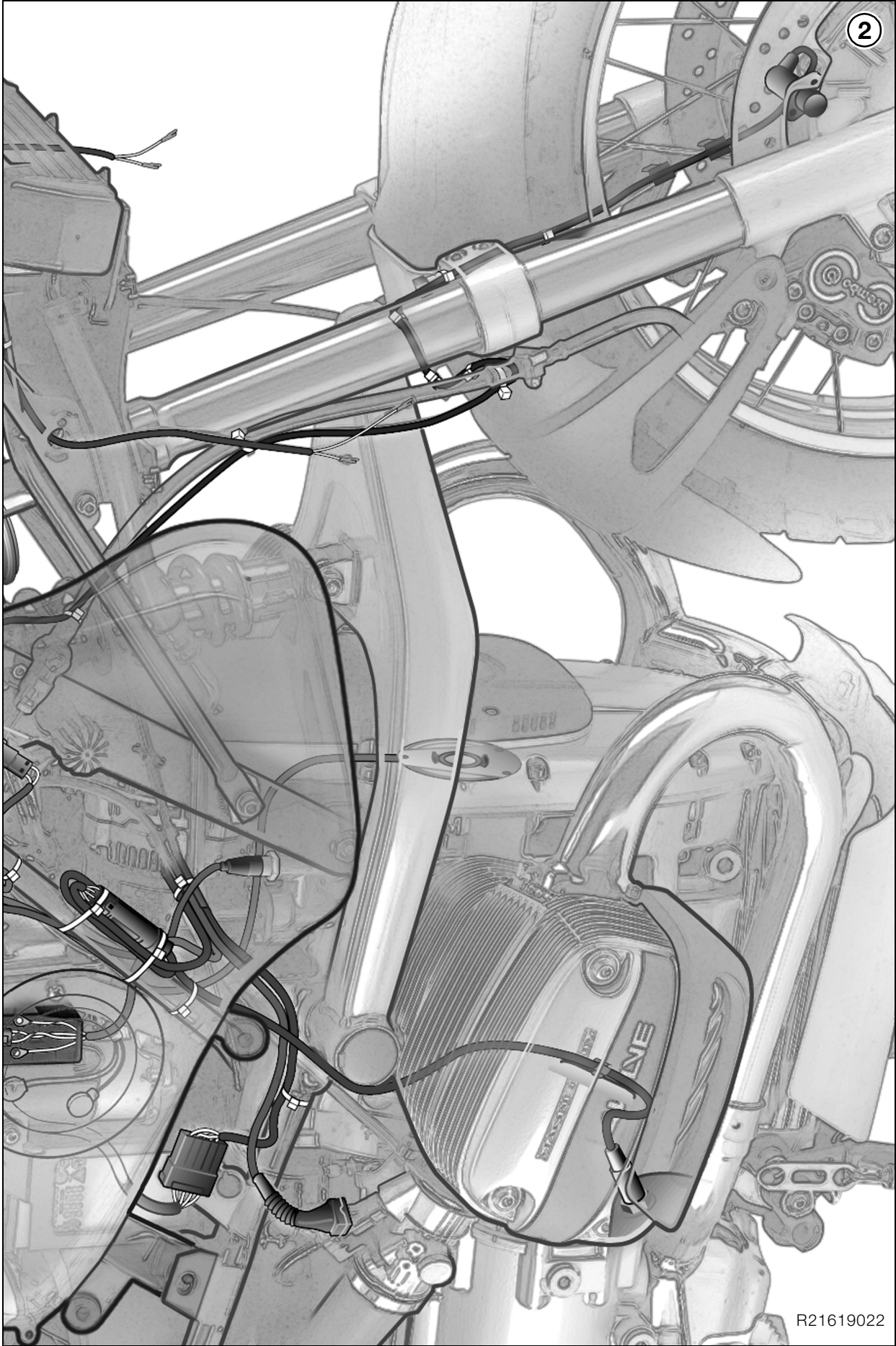

R21619022



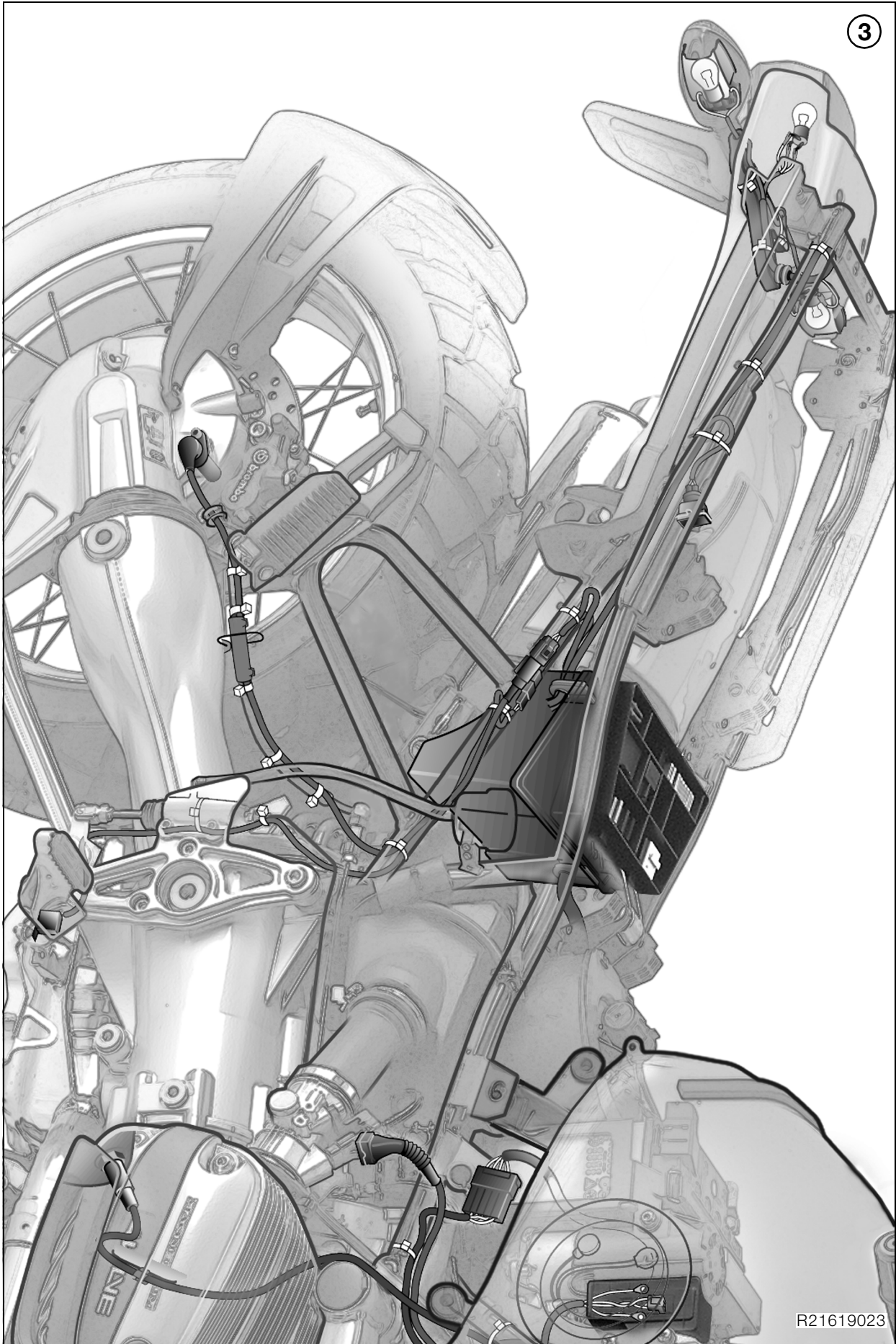

R21619023

Removing and installing battery holder

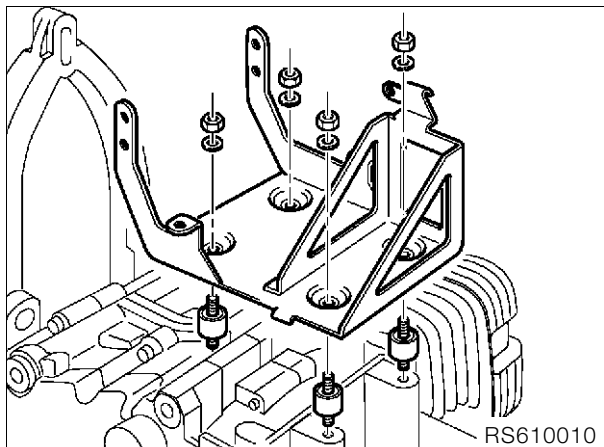

- Remove fuel tank.
- Remove the battery.



Caution:

Disconnect the negative battery terminal first, then the positive terminal.

Connect the positive battery terminal first, then the negative terminal.

- Remove Motronic control unit.
- **[ABS]** Remove the unit.
- Remove the air intake stub pipe.
- Disconnect Bowden cable for starting-speed increase from handlebar fitting.
- Disconnect cable from left throttle valve.
- Remove Bowden-cable divider from holder.
- Pull the battery holder to the left to remove.
- Installation is the reverse of the removal procedure.
- Switch on the ignition.
- Without starting the engine, fully open the throttle once or twice so that the Motronic control unit can register the throttle-valve positions.



Note:

Disconnecting the battery deletes all entries (e.g. faults, settings) stored in the Motronic control unit's memory.

Loss of settings can temporarily impair the operating characteristics when the engine is restarted.

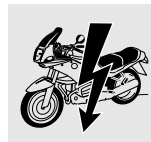

62 Instruments

Contents

Page

Technical Data 3

Removing and installing instrument panel 4





Technical Data	R 1150 GS
Instrument cluster	
Telltale lights, turn indicator/high-beam headlight	A 14 V 3 W
Instrument lighting/telltale lights	A 12 V 1.7 W
Speedometer drive	
Speedometer drive ratio	I = 3.0



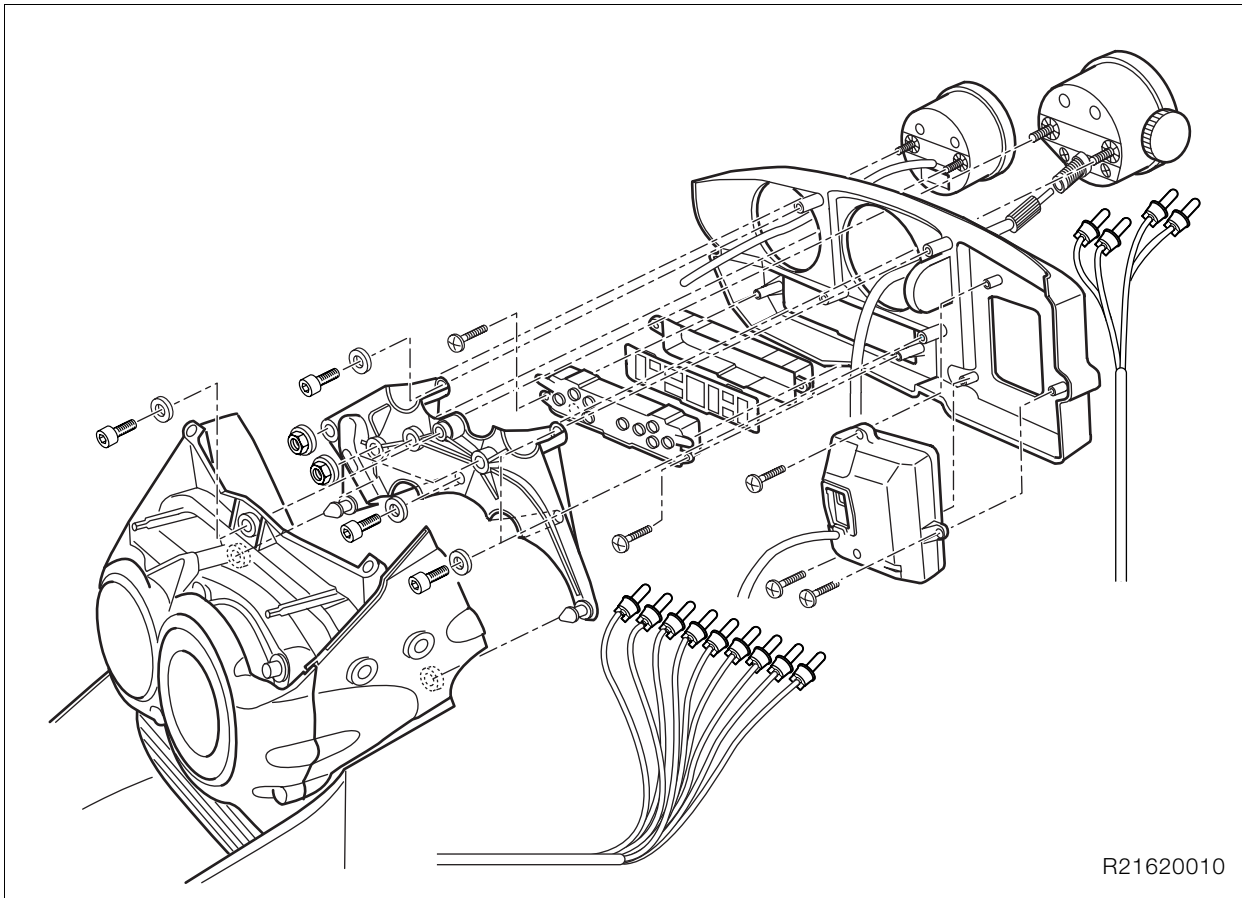

R21620010

Removing and installing instrument panel



Caution:

Switch off ignition.
Disconnect earth (ground) lead from battery.
Insulate earth (ground) lead.

- Remove windscreen.
- Remove top cover.
- Remove fastener securing instrument cluster to front mount.
- Pull the instrument cluster up until it is clear of the front mount.



Note:

Carefully pull thrust pad (1) on bracket (4) of instrument carrier out of the front mount.

- Remove bracket (4) of instrument carrier.

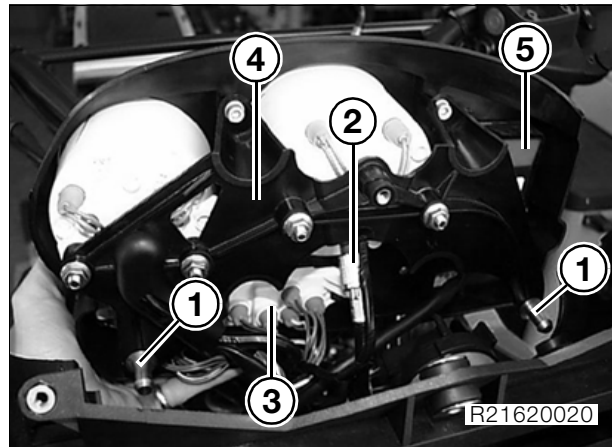

R21620020

- Remove telltale-light unit (3).
- If applicable, remove rider information display (5).
- Disconnect speedometer drive (2).
- Remove instrument lighting.
- Installation is the reverse of the removal procedure.

63 Lights

Contents

Page

Technical Data	3
Removing and installing headlight	4
Removing and installing front indicators	5



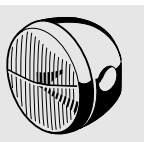

Technical Data	R 1150 GS
Headlight	Twin halogen headlights
Bulbs	
Low (dipped) beam headlight	H1 halogen bulb 12 V/55 W
High (main) beam headlight	H1 halogen bulb 12 V/55 W
Parking light	12 V/4 W Standard designation T 8/4
Brake light/rear light	12 V/ 21/5 W Standard designation P 25-2
Flashing turn indicator	12 V/21 W Standard designation P 25-1

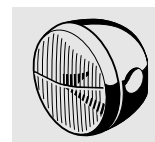

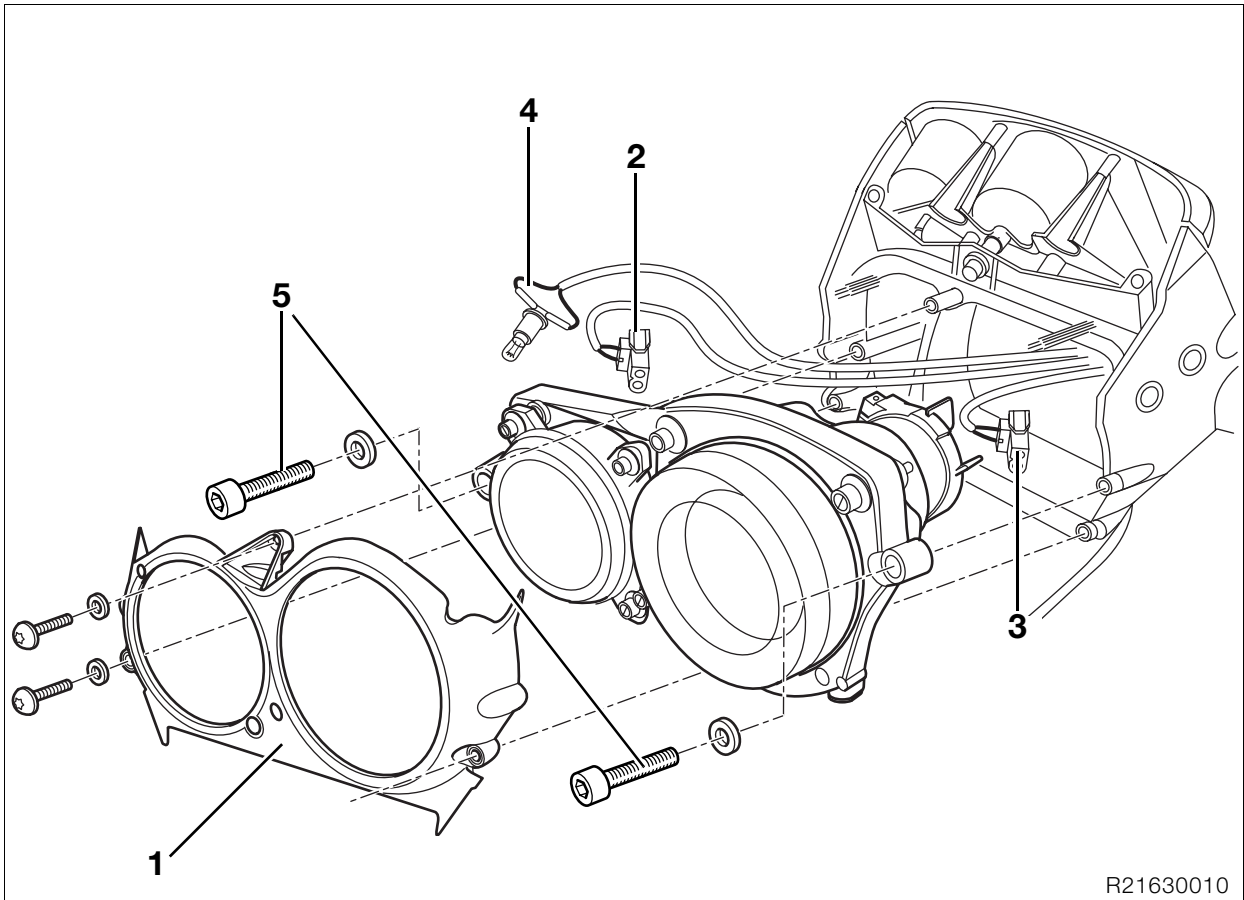

R21630010

Removing and installing headlight



Caution:

Switch off ignition.
Disconnect earth (ground) lead from battery.
Insulate earth (ground) lead.

- Remove windscreen.
- Remove top cover.
- Remove headlight glass (1).
- Disconnect plug (2) from protective cap, high-beam headlight.
- Disconnect plug (3) from protective cap, low-beam headlight.
- Pull bulb holder (4) of the parking light out of the headlight housing.
- Remove fastener (5) securing the headlight holder.

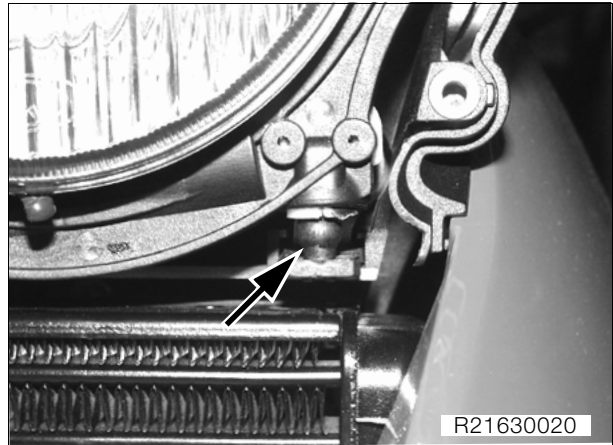

R21630020



Note:

Carefully pry the ball head (arrow) of the headlight adjuster out of the headlight holder.

- Remove headlight holder complete with headlight.



Caution:

Never touch the glass of the bulb with the fingers.

- Installation is the reverse of the removal procedure.

Removing and installing front indicators



Caution:

Switch off ignition.
Disconnect earth (ground) lead from battery.
Insulate earth (ground) lead.

- Remove the indicator lenses, disconnect plug from reflector and pull the cable through the indicator mount.



Caution:

Do not touch inner surface of reflector or bulbs with bare hands.

- Remove the turn indicator.
- Installation is the reverse of the removal procedure.

