

BenQ DC E63+ Digital Camera
User's Manual

Welcome

Copyright

Copyright 2005 by BenQ Corporation. All rights reserved. No part of this publication may be reproduced, transmitted, transcribed, stored in a retrieval system or translated into any language or computer language, in any form or by any means, electronic, mechanical, magnetic, optical, chemical, manual or otherwise, without the prior written permission of this company.

Disclaimer

BenQ Corporation makes no representations or warranties, either expressed or implied, with respect to the contents hereof and specifically disclaims any warranties, merchantability or fitness for any particular purpose. Further, BenQ Corporation reserves the right to revise this publication and to make changes from time to time in the contents hereof without obligation of this company to notify any person of such revision or changes.

*Windows, Internet Explorer and Outlook Express are trademarks of Microsoft Corporation. Others are copyrights of their respective companies or organizations.

Taking care of your camera

- Do not use your camera in the following environmental range: temperature below 0°C or above 40°C.
- Do not use or store your camera in the environments listed below:
 - Direct sunlight
 - High and dusty places
 - Next to an air conditioner, electric heater or other heat sources
 - In a closed car that is in direct sunlight
 - Unstable locations
- If your camera becomes wet, wipe it with a dry cloth as soon as possible.
- Salt or seawater may cause severe camera damage.
- Do not use organic solvents such as alcohol, etc., to clean your camera.
- If the lens is dirty, use a lens brush or soft cloth to clean the lens. Do not touch the lens with your fingers.
- To prevent electric shock, do not attempt to disassemble or repair your camera by yourself.
- Water may cause a fire or electric shock. Therefore, store your camera in a dry place.
- Do not use your camera outdoors when it is raining or snowing.
- Do not use your camera in or near water.
- If a foreign substance or water gets in your camera, please turn the power off immediately and disconnect the batteries and the power adapter. Remove the foreign substance or water, and send it to the maintenance center.
- Transfer the data to the computer as soon as possible to avoid losing your images and/or video clips.

Disposal of Waste Electrical and Electronic Equipment by users in private households in the European Union.



This symbol on the product or on the packaging indicates that this can not be disposed of as household waste. You must dispose of your waste equipment by handing it over to the applicable take-back scheme for the recycling of electrical and electronic equipment. For more information about recycling of this equipment, please contact your city office, the shop where you purchased the equipment or your household waste disposal service. The recycling of materials will help to conserve natural resources and ensure that it is recycled in a manner that protects human health and environment.

Table of Contents

1. TOURING YOUR DC E63+	1
1.1 Checking the Package Contents	1
1.2 DC E63+ Components.....	1
1.2.1 Front View	1
1.2.2 Rear View	2
1.2.3 Status LED Indicator	2
2. PREPARING YOUR DC E63+ FOR USE	3
2.1 Installing the Battery	3
2.2 Charging the Battery	3
2.3 Using an AC Power Adapter	4
2.4 Inserting and Removing an SD Memory Card (Optional Accessory).....	4
3. USING THE DC E63+	5
3.1 Capture Mode.....	5
3.1.1 Capture Mode LCD Monitor Information	6
3.1.2 Changing Camera Settings	7
3.1.2.1 Using the Flash	7
3.1.2.2 Using the Self-Timer	8
3.1.2.3 Using the Optical Zoom	8
3.1.2.4 Deleting Images	9
3.1.3 Capture Mode Menu Settings	9
3.1.3.1 Capture Mode Menu	9
3.1.3.2 Capture Mode Function Menu	12
3.2 Movie Mode	14
3.2.1 Movie Mode LCD Monitor Information.....	14
3.2.2 Movie Mode Menu Settings.....	15
3.2.2.1 Movie Mode Function Menu.....	15
3.3 Playback Mode	16
3.3.1 Playback Mode LCD Monitor Information (Image).....	16
3.3.2 Viewing Images	16
3.3.2.1 Rotating Images	16
3.3.2.2 Magnifying Images	17
3.3.2.3 Thumbnail Display (Index Playback)	17
3.3.2.4 Erasing Images/Movies in Playback Mode	18
3.3.3 Playback Mode Menu Settings	18
3.3.3.1 Playback Mode Protect.....	19
3.3.4 Playback Mode LCD Monitor Information (Video)	20
3.3.5 Playing Back Video Clips.....	20
3.4 Setup Mode	21
3.4.1 Setup Menus in Camera and Movie Mode.....	21
3.4.2 Setup Menus in Playback Mode.....	22

4. PC DEPENDENT FEATURES	23
4.1 Bundled Software	23
4.2 USB Mode	23
4.3 Printer Mode	24
4.3.1 Connecting the Camera to the Printer	24
4.3.2 Printing images.....	24
5. TROUBLESHOOTING	26
6. SPECIFICATIONS	28
6.1 System Requirements	28
7. SERVICE INFORMATION.....	29

1 TOURING YOUR DC E63+

1.1 Checking the Package Contents

Carefully unpack your box and ensure that you have the following items.

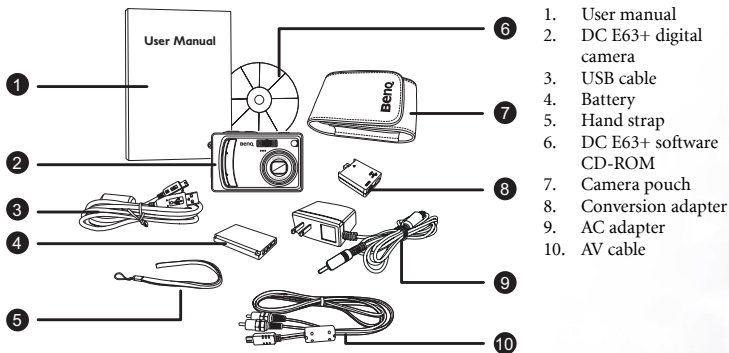



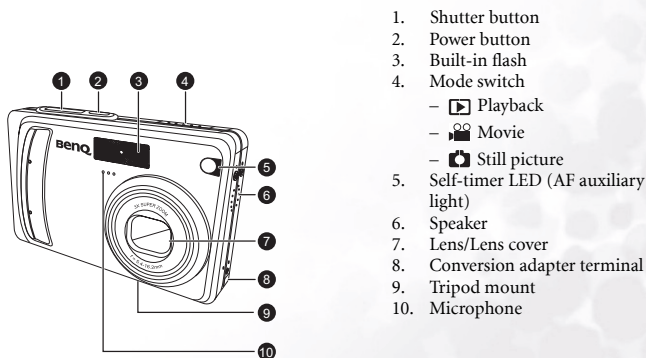

If any of the items are missing or appear to be damaged, contact your dealer. Save the packaging in case you need to ship your camera for service.

1.2 DC E63+ Components

1.2.1 Front View



1.2.2 Rear View

1. LCD monitor
2.  Display mode button
3. Status LED
4.  Zoom in button
 Zoom out button
5.  MENU Menu button
6.  Delete button
7. Strap eyelet
8. Control and Set buttons
9. Battery / SD memory card cover
10. Tripod socket

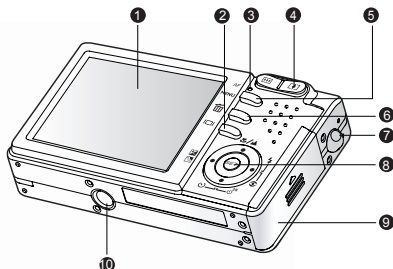

-  • The LCD on the digital camera is manufactured with sophisticated technology; however, the display may have some light spots or show unusual colors. This is normal and does not indicate display malfunction, nor will this affect the pictures you take with the camera.

1.2.3 Status LED Indicator

Color	State	During Power Off	During Photography	During Connection to PC
Green	On	—	Ready for shooting	System ready
Red	On	Battery charging in progress	—	—
	Off	Battery charging completed	—	—
	Flashing	—	File access in progress. Flash charge in progress.	File access in progress

2 PREPARING YOUR DC E63+ FOR USE

2.1 Installing the Battery

We highly recommend that you use only the specified rechargeable lithium-ion battery for your digital still camera. Make sure that the camera power is off before inserting or removing the battery.

1. Open the battery/SD memory card cover (A).
2. Insert the battery in the correct orientation shown (B).
Place the battery so that its label is facing the rear side of the camera, and then insert the battery.
3. Close the battery/SD memory card cover (C).

To remove the battery:

Open the battery/SD memory card cover and then release the battery lock lever. When the battery has come out a little, slowly pull it out the rest of the way.

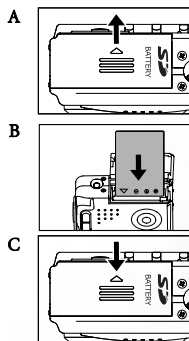

2.2 Charging the Battery

The battery charge status affects the performance of the DC E63+. To maximize the performance and life of the battery, it is recommended that you fully charge the battery using the optional AC power adapter and then fully discharge it (through normal use) at least once. Make sure that the camera power is off before inserting the battery.

1. Insert the conversion adapter into the conversion adapter terminal of the camera as shown in the illustration.
2. Connect one end of the AC power adapter to the DC IN terminal of the conversion adapter.
3. Connect the other end of the AC power adapter to a wall outlet.
Charging times differ depending on the ambient temperature and the status of the battery.

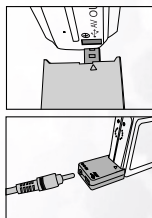

- The DC E63+ must be used with the specified AC power adapter. Damage caused by the use of an incorrect adapter is not covered under the warranty.
- Always make sure that the camera power is off before removing the battery.
- The battery may feel warm after it has been charged or immediately after being used. This is normal and not a malfunction.
- When using the camera in cold environments, keep the camera and its battery warm by holding it inside your jacket or other warm protective environment.

2.3 Using an AC Power Adapter

Using an AC power adapter prevents the DC E63+ from automatically powering off while transferring files to your computer.

See the preceding section to learn how to charge the battery.



- **Make sure that you use only the AC power adapter specified for the camera. Damage caused by the use of an incorrect adapter is not covered under the warranty.**

2.4 Inserting and Removing an SD Memory Card (Optional Accessory)

The DC E63+ is equipped with internal memory, allowing you to record video clips, capture images or voice files in the digital still camera. However, you can also expand the memory capacity using an optional SD (Secure Digital) memory card.

1. Always make sure the digital still camera is turned off before inserting or removing a memory card.
2. Insert an SD memory card with the correct orientation as shown in the illustration.
3. Close the battery/SD memory card cover.

To remove the SD memory card, make sure the camera is turned off. Press lightly on the edge of the memory card and it will eject.

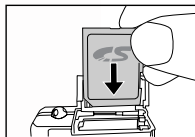

- **SD memory cards in the following sizes are supported: 8MB, 16MB, 32MB, 64MB, 128MB, 256MB, 512MB, and 1GB.**
- **The DC E63+ is compatible with SD memory cards manufactured by Panasonic, Toshiba, and Sandisk. Please contact your local dealer for purchasing information.**

3 USING THE DC E63+

3.1 Capture Mode





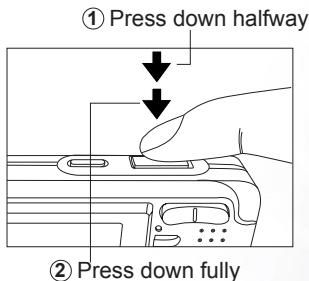



















1. Press the POWER button to turn on the camera.
2. Slide the mode switch to [].
3. Compose your image in the LCD monitor.
4. Press the shutter button down halfway (1), then press it down fully (2).

- Pressing the shutter button down halfway automatically focuses and adjusts the exposure.
- The focus area frame turns blue when the camera is focused and the exposure is determined.
- When the focus or exposure is not suitable, the frame of the focus area turns yellow.
- If the photographic preview is set to "ON", the captured image will be displayed while the image is being recorded onto the memory.









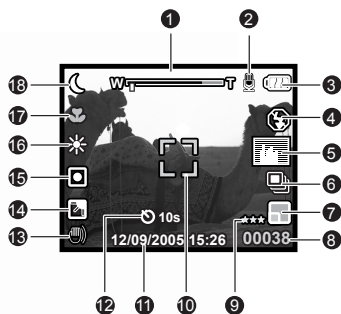













- **The LCD monitor darkens in strong sunlight or bright light. This is not a malfunction.**
- **To prevent your images from being blurred while pressing the shutter button, always hold the camera steady. This is especially important when you are shooting under low lighting conditions, under which your camera may reduce the shutter speed to ensure your images are properly exposed.**
- **Pressing the  button changes the LCD display in the sequence of: Standard Display → Simplified Display → No Information.**
- **To review the last captured image, press the SET button. Press the SET button again to return to the camera mode.**

3.1.1 Capture Mode LCD Monitor Information

- Zoom status
- Voice memo
- Battery power indicator
 - [] Full battery power
 - [] Medium battery power
 - [] Low battery power
 - [] No battery power
- Flash mode
 - [] Auto
 - [] Red-eye reduction
 - [] Forced flash
 - [] No flash
- [] Histogram
- Capture mode icon
 - [Blank] Single
 - [] Continuous
 - [] AEB
- Image size (resolution)
 - [] 2816 x 2112
 - [] 2272 x 1704
 - [] 1600 x 1200
 - [] 640 x 480
- Available number of shots
- Image quality
 - [] Fine
 - [] Standard
 - [] Economy
- Focus area (when shutter is pressed half-way)
- Date and time
- Self-timer icon (if used)
 - [] 10-second delay
 - [] 2-second delay
 - [] 10+2-second delay
- [] Unsteady hold warning icon
- [] Exposure compensation
- [] Backlight correction



- Metering icon
 - [Blank] Average
 - [] Spot
- White balance
 - [Blank] Auto
 - [] Incandescent
 - [] Fluorescent 1
 - [] Fluorescent 2
 - [] Daylight
 - [] Cloudy
 - [] Manual
- Focus icon
 - [Blank] Auto focus
 - [] Macro
 - [] Infinity
- Scene mode

[] Program AE	[] Candlelight
[] Panorama	[] Text
[] Portrait	[] Sunset
[] Landscape	[] Sunrise
[] Sports	[] Splash water
[] Night	[] Fireworks

3.1.2 Changing Camera Settings

Camera settings can be changed with the five-way button.

1. **Right/Flash:** Scrolls right in menus and enables you to choose the appropriate flash setting.
2. **Left/Exposure Compensation:** Scrolls left in menus and enables you to set the exposure compensation and backlight correction.
3. **Up/Macro:** Scrolls upwards in menus and toggles the macro settings.
4. **Down/Self-Timer:** Scrolls downwards in menus and cycles through the self-timer settings.
5. **SET:** Enters the menu page and confirms the chosen setting.

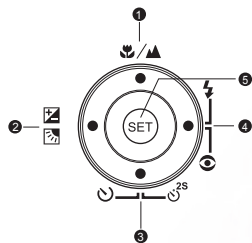

3.1.2.1 Using the Flash

The flash is designed to function automatically when lighting conditions warrant the use of flash. You can capture an image using a flash mode suitable to your circumstances.

1. Press the **POWER** button to turn on the camera.
2. Slide the mode switch to [].
3. Press the **Right/Flash** button to cycle through the flash modes.
4. Compose your scene and press the shutter button.

The table below will help you choose the appropriate flash mode:

Icon	Scene Mode	Description
	AUTO FLASH	The flash fires automatically according to the photographic conditions.
	ANTI RED-EYE FLASH	Use this mode to reduce the red-eye phenomenon when you want to capture natural-looking images of people and animals in low-light conditions. When capturing images, the red-eye phenomenon can be reduced by asking the subject (person) to look at the camera lens or get as close to the camera as possible.
	FORCED FLASH	The flash will always fire regardless of the surrounding brightness. Select this mode for recording images with high backlighting and deep shadows.
	NO FLASH	Use this mode in environment where flash use is prohibited or if the distance to the subject is too far away for the flash to have any effect.

- In [] landscape and [] macro modes, the flash is fixed at [].
- In [] continuous and [] AEB capture modes, the flash is fixed at [].
- The flash cannot be used in video capture [] mode.

3.1.2.2 Using the Self-Timer

The self-timer can be set in [📷] mode. This feature is useful for situations where you may wish to be part of the picture.

1. Secure the camera to a tripod or place it on a stable surface.
2. Press the POWER button to turn on the camera.
3. Slide the mode switch to [📷].
4. Toggle the **Down/Self-timer** button to select the desired self-timer mode.



5. Compose your image and press the shutter button.

- The self-timer function is activated and the countdown status is displayed on the LCD monitor.
- The self-timer LED flashes and the image will be captured after the preset time has elapsed.
- To cancel the self-timer at any time, press the shutter button.



- **The self-timer setting is automatically turned off after an image is captured.**
- **The 10+2 second option takes two pictures: one after 10 seconds, and then another two seconds afterward.**

3.1.2.3 Using the Optical Zoom

Zoom photography allows you to capture images magnified up to 3 times or wide-angle photography depending on the distance from the subject. You can further enlarge the center of the screen and capture images using the digital zoom.

1. Slide the mode switch to [📷] or [📷].
2. Adjust the image with the zoom button.
 - Pressing the [🔍] button zooms in on the subject, and enlarges the subject on the LCD screen.
 - Pressing the [📷] button provides a wide angle image.
 - The lens position moves according to the zoom button setting and the slider in the LCD shows the zoom position.
3. Press the shutter button down halfway to set the focus and exposure, then press it down fully to capture the image.

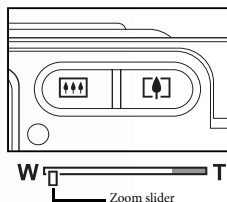

3.1.2.4 Deleting Images

Use this function to delete one or all images/video clips stored in the internal memory or memory card. Please note that the deleted images and video clips cannot be recovered.

Immediate Erase (Quick Delete Function)

The quick delete function enables you to delete an image immediately after capturing it.

- Slide the mode switch to [📷] or [📹].
- Press the  button.
The last image and delete message appears on the screen.
- Use the **UP/DOWN** buttons to select [Execute], then press the **SET** button.
If you wish to cancel the deletion, select [Cancel].

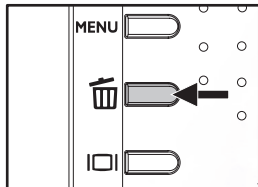

 • Protected images cannot be deleted.







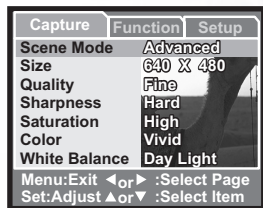

3.1.3 Capture Mode Menu Settings

3.1.3.1 Capture Mode Menu

- Slide the mode switch to [📷].
- Press the **MENU** button to access the menu, then use the **RIGHT/LEFT** buttons to select the [Capture] menu.
- Use the **UP/DOWN** buttons to select the desired item in the [Capture] menu, then press the **SET** button to view available settings for the item.
- Use the **UP/DOWN** buttons to select the desired setting and press the **SET** button to confirm.
- To exit from the menu, press the **MENU** button.





Icon	Item	Functional Description
	SCENE MODE	<p>Enables you to choose among the following scenes:</p> <p>[] Program AE: Select this mode to capture images without having to set special functions or manual adjustments.</p> <p>[] Panorama: Select this mode to take a series of shots then stitch them together with software to make a single photo.</p> <p>[] Portrait AE: Select this mode when you want to capture an image that makes the person stand out against an unfocused (blurred) background. The flash mode is set to [] which is effective in reducing the red-eye phenomenon.</p> <p>[] Landscape: Select this mode to capture an image with focus set to infinity, hard sharpness, and high saturation.</p> <p>[] Sports: Select this mode when you want to photograph fast-moving subjects.</p> <p>[] Night: Select this mode when you want to capture people with an evening or night scene background.</p> <p>[] Candlelight: Select this mode when you want to capture photos of candlelit scene, without spoiling the atmosphere.</p> <p>[] Text: Select this mode when you want to capture an image that contains black and white subjects like printed documents.</p> <p>[] Sunset: Select this mode when you want to capture photos of sunset scene. This mode helps keep the deep hues in the scene.</p> <p>[] Sunrise: Select this mode when you want to capture photos of sunrise scene. This mode helps keep the deep hues in the scene.</p> <p>[] Splash: Select this mode when you want to capture photos of splashing water.</p> <p>[] Fireworks: Select this mode when you want to capture fireworks clearly with optimum exposure. The shutter speed becomes slower, so using a tripod is recommended.</p> <p>Note: The description of each scene serves as a general guide for your convenience. Set the digital still camera to suit your own preferences.</p>
	SIZE	<p>Sets the size of the image that will be captured.</p> <p> 2816 x 2112</p> <p> 2272 x 1704</p> <p> 1600 x 1200</p> <p> 640 x 480</p>
***	QUALITY	<p>Sets the quality (compression rate) at which the image is captured.</p> <p>*** Fine</p> <p>** Standard</p> <p>* Economy</p>
—	SHARPNESS	<p>Sets the level of image sharpness.</p> <p>Hard</p> <p>Normal</p> <p>Soft</p>

Icon	Item	Functional Description
—	SATURATION	High Normal Low
—	COLOR	Sets the color of the image that will be captured. Standard Vivid Sepia Monochrome
	WHITE BALANCE	This sets the white balance for a variety of lighting conditions and ensures captured images look like those seen by the human eye. [Blank] Auto: [] Incandescent [] Fluorescent 1 [2] Fluorescent 2 [] Daylight [] Cloudy [] Manual
	MANUAL WB	Allows you to set the white balance manually. Manual WB is convenient when the white balance presets do not offer a good match to your specific lighting conditions. Before selecting [EXECUTE], select a white subject (such as a white paper) that will be used to set the white balance. – EXECUTE/CANCEL
	ISO	This sets the sensitivity for capturing images. When the sensitivity is raised (and the ISO figure is increased), photography will become possible even in dark locations, but the more pixelated (grainier) the image will appear. 50 100 200 400 Auto
	METERING	This sets the metering method for calculating the exposure. — Average: Averages the light metered from the entire frame, but gives greater weight to the subject matter at the center.  Spot: A very small portion of the center of the screen is measured, and the exposure is calculated.

3.1.3.2 Capture Mode Function Menu

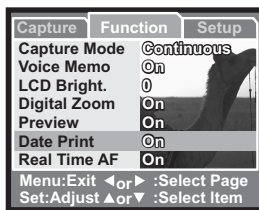
- Slide the mode switch to [].
- Press the **MENU** button to access the menu, then use the **RIGHT/LEFT** buttons to select the [Function] menu.
- Use the **UP/DOWN** buttons to select the desired item in the [Function] menu, then press the **SET** button to view available settings for the item.
- Use the **UP/DOWN** buttons to select the desired setting and press the **SET** button to confirm.
- To exit from the menu, press the **MENU** button.



Item	Functional Description
CAPTURE MODE	Sets the recording method at the time of capturing images. — Single: Capture a single image at a time.  Continuous: Capture three images in a row at the press of the shutter button. AEB AEB: Permits 3 consecutive images in the order of standard exposure, underexposure and overexposure compensation.
VOICE MEMO	Enables or disables the voice memo feature. — On — Off
LCD BRIGHTNESS	Selects a brightness level for the LCD screen. The adjustment range is from -5 to +5.
DIGITAL ZOOM	Enables or disables digital zoom. — On — Off
PREVIEW	Enables the display of a captured image on the LCD monitor immediately after you have captured the image. — On — Off
DATE PRINT	Enables or disables the date print feature. — On — Off
REAL TIME AF	Enables and disables the real time autofocus feature. — On — Off

3.1.3.2.1 Continuous Capture

In continuous capture mode, you can capture a rapid sequence of images with one press of the shutter button. This function is very useful for photographing objects in motion where it is difficult to determine the precise moment of capture. Afterwards, you may review the sequence of images to select the best one.

- Use the **UP/DOWN** buttons to select [CONTINUOUS], then press the **SET** button.
- To exit from the menu, press the **MENU** button.
 The  indicator is displayed on the monitor screen.
- Press the shutter button down halfway to lock the focus.
- Press the shutter button down all the way to capture images.

- **Maximum number of continuous shots: 3.**
- **In CONTINUOUS mode, the flash mode will be set to NO FLASH automatically.**

3.1.3.2.2 Auto-Exposure Bracketing (AEB)

Auto-exposure bracketing is an effective technique when it is difficult to determine the precise exposure of a scene. Using AEB the camera will capture a burst of three images at three different exposure settings. Afterwards, you may review the sequence of images to select the best exposure.

- **In AEB mode, the flash mode will be set to NO FLASH automatically.**

3.1.3.2.3 Using Voice Memo

This feature enables you to attach voice notes to your photographs.

To attach a voice memo:

1. Enable voice memo in the Capture mode Function menu. The microphone icon  appears in the LCD screen.
2. Take a picture as usual. After the picture is taken, the voice recording screen appears.
3. Record your voice memo.
4. Press the Shutter button to stop voice recording.

Pictures with a voice memo attached have the microphone icon on them in Playback mode.



- **The voice memo setting is disabled when continuous or AEB are enabled in capture mode.**

3.1.3.2.4 Using the Digital Zoom

Using a combination of 3X optical zoom and 4X digital zoom permits zoom photography up to 12X to suit the subject and the distance. Digital zoom is a useful feature, however, the more an image is enlarged (zoomed) with the digital zoom, the more pixelated (grainy) the image will appear.

3.2 Movie Mode

1. Press the POWER button to turn on the camera.
2. Slide the mode switch to [].
3. Compose the image with the zoom button, if desired.
4. Press the shutter button to start recording.
5. Press the shutter button again to stop recording.

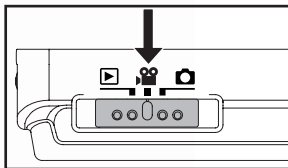

- The flash and self-timer cannot be used in [] mode.
- While a video is being recorded to an SD card, do not open the battery/SD card cover, nor remove the battery or SD card. Doing so might damage the SD card or destroy the data.

3.2.1 Movie Mode LCD Monitor Information

1. Movie mode
2. Zoom status
3. Battery power indicator
4. Available recording time/Elapsed time
5. Date and Time

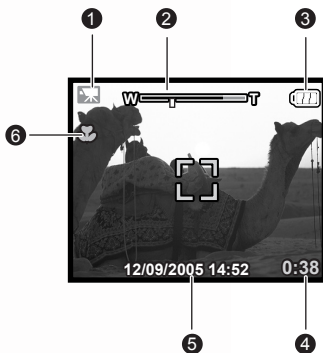

3.2.2 Movie Mode Menu Settings

- Slide the mode switch to [].
- Press the **MENU** button to access the menu, then use the **RIGHT/LEFT** buttons to select the [Capture] menu.
- Use the **UP/DOWN** buttons to select the desired item in the [Capture] menu, then press the **SET** button to view available settings for the item.
- Use the **UP/DOWN** buttons to select the desired setting and press the **SET** button to confirm.
- To exit from the menu, press the **MENU** button.



Item	Functional Description
SIZE	Sets the size of the video clip that will be recorded. <ul style="list-style-type: none"> - 640 x 480 - 320 x 240
QUALITY	Sets the quality of the video clip that will be captured. <ul style="list-style-type: none"> - Fine - Standard
COLOR	Sets the color of the video clip that will be captured. <ul style="list-style-type: none"> - Standard - Vivid - Sepia - Monochrome

3.2.2.1 Movie Mode Function Menu

- Slide the mode switch to [].
- Press the **MENU** button to access the menu, then use the **RIGHT/LEFT** buttons to select the [Function] menu.
- Use the **UP/DOWN** buttons to select the desired item in the [Function] menu, then press the **SET** button to view available settings for the item.
- Use the **UP/DOWN** buttons to select the desired setting and press the **SET** button to confirm.
- To exit from the menu, press the **MENU** button.



Item	Functional Description
AUDIO	Enables and disables recording of audio. <ul style="list-style-type: none"> - On - Off
LCD BRIGHT	Selects a brightness level for the LCD monitor. The adjustment range is from -5 to +5.
DIGITAL ZOOM	Enables and disables the digital zoom. <ul style="list-style-type: none"> - On - Off

3.3 Playback Mode

In playback mode, you can view, magnify, or delete images, play video clips, or run a slide show. This mode also provides a thumbnail image display, allowing you to search quickly for the desired image.

1. Press the POWER button to turn on the camera.
2. Slide the mode switch to [▶].
3. Use the **LEFT/RIGHT** buttons to select the desired images or movies.
 - To view the previous image, press the **LEFT** button.
 - To view the next image, press the **RIGHT** button.

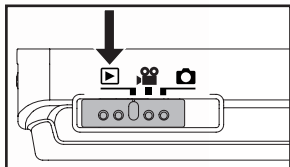

3.3.1 Playback Mode LCD Monitor Information (Image)

1. Playback mode
2. Battery power indicator
3. File number
4. Locked (if applicable)
5. Voice Memo (if one is attached)
6. Date picture taken



3.3.2 Viewing Images

3.3.2.1 Rotating Images

Pressing the **UP/DOWN** buttons during image playback will rotate the image 90 degrees. The **UP** button rotates the image clockwise, whereas the **DOWN** button rotates the image counterclockwise.

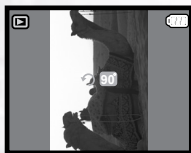

90° Counterclockwise



0° (Original)

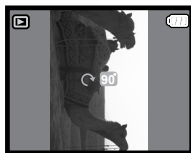

90° Clockwise

- If there is no image stored in the internal memory or memory card, a [NO PICTURE] message will appear on the screen.
- Pressing the [] button while playing back images changes the LCD display in the sequence of: Standard display → Detailed display → No information.

3.3.2.2 Magnifying Images

While reviewing your images, you may enlarge a selected portion of an image. This magnification allows you to view the details of the image. The DC E63+ provides 4X magnification during playback.

- Adjust the zoom ratio by using the zoom button.
 - To enlarge the selected image, press the [] button.
 - To return to normal magnification, press the [] button.
 - The magnification factor is displayed on the LCD screen.
- To view different portion of the images, press the **UP/DOWN/LEFT/RIGHT** buttons to adjust the display area.

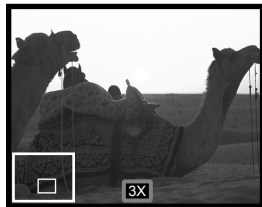

You will see a white frame with a pink box inside. The white frame indicates the entire image, while the pink box shows the location of the currently enlarged area.

- To return to regular display, press [] until the normal image (1X magnification) appears on the screen.

- The range of magnification factor is: 1.5x, 2.0x, 2.5x, 3.0x, 3.5x, and 4.0x.

3.3.2.3 Thumbnail Display (Index Playback)

This function allows you to view four or nine thumbnail images on the LCD monitor simultaneously so you may search for a particular image.

- Press the [] button.
Four or nine thumbnail images are displayed simultaneously.
- Use the **UP/DOWN/LEFT/RIGHT** buttons to select the image to be displayed at regular size, then press the **SET** or [] button to display the selected image in full screen mode.

- If the file is a video, the [] icon will be displayed in the thumbnail display. If a Voice Memo is attached, the [] icon will be displayed.



3.3.2.4 Erasing Images/Movies in Playback Mode

Erasing a single image or movie / Erasing all images and movies

- Slide the mode switch to [▶].
The last image/movie taken is displayed on the screen.
- Use the **LEFT/RIGHT** buttons to select the image/movie you want to erase.
- Press the [🗑️] button.
The Delete menu is displayed.
- Use the **UP/DOWN** buttons to select [Single], [All], or [Select] and press the **SET** button.

Single: Erases the selected image/movie or the last image/movie.

Use the **UP/DOWN** buttons to select [Execute] and press the **SET** button. To cancel the deletion, select [Cancel], and press the **SET** button.

All: Erases all of the images/movies on the SD card except for protected files.

Use the **UP/DOWN** buttons to select [Execute] and press the **SET** button. To cancel the deletion, select [Cancel], and press the **SET** button.

Select: Erases a number of selected images/movies. Press **SET** to display thumbnails of all images and movies. Use the **UP/DOWN/LEFT/RIGHT** buttons to select the image or movie. Press [🗑️] to tag the image/movie for deletion. Press **SET** to confirm deletion.

3.3.3 Playback Mode Menu Settings

- Slide the mode switch to [▶].
- Press the **MENU** button to access the PLAY menu.
- Use the **UP/DOWN** buttons to select the desired item in the [Play] menu, then press the **SET** button to view available settings for the item, or to view the submenu.
- Use the **UP/DOWN** buttons to select the desired setting and press the **SET** button to confirm.
- To exit from the menu, press the **MENU** button.



Item	Functional Description
SLIDESHOW	This function enables you to set the time interval while playing back your images automatically in sequential order as a slide show. This is a very useful and entertaining feature for reviewing recorded images and for presentations. <ul style="list-style-type: none"> - 3 sec. - 5 sec. - 10 sec.
DPOF	DPOF (Digital Print Order Format) allows you to embed printing information on your memory card. Files saved in the DPOF format can be printed using compatible printers or through a laboratory printing device. Refer to "Printer Mode" on page 24 for information on using DPOF.

Item	Functional Description
PROTECT	Sets the data to read-only to prevent images from being erased by mistake. <ul style="list-style-type: none"> - Single: Protect a single image. - All: Protect all images. - Select: Select which images to protect.
LCD BRIGHT	Selects a brightness level for the LCD monitor. The adjustment range is from -5 to +5.
RESIZE	Changes the size of a recorded image. <ul style="list-style-type: none"> - 2272 x 1704 - 1600 x 1200 - 640 x 480
QUALITY CHANGE	Enables you to convert the quality: <ul style="list-style-type: none"> - Standard: Changes an image at Fine quality to Standard. - Economy: Changes an image at Fine or Standard quality to Economy.
COPY TO CARD	Allows you to copy your files from the camera's internal memory to a memory card. Of course, you can only do this if you have a memory card installed and some files in internal memory. <ul style="list-style-type: none"> - Yes - No

3.3.3.1 Playback Mode Protect

This function allows you to lock an image to prevent it from being deleted or modified.

1. Press **SET** to enter the [Protect] submenu

A submenu appears listing Protect options.

Single: Protects the selected image/movie or the last image/movie.

All: Protects all of the images/movies on the SD card.

Select: Erases a number of selected images/movies.

Refer to **Using Select** below.



2. Use the **UP/DOWN** buttons to select an option, then press the **SET** button to display the next submenu.
3. **UP/DOWN** buttons to select an option, then press the **SET** button to confirm.

Set: Sets protection for the image or movie, or all images and movies.

Cancel Protect: Removes protection.

Exit: Exits the menu.



- **Protected images are marked with a lock icon.**

Using Select

Press **SET** to display thumbnails of all images and movies.

Use the **UP/DOWN/LEFT/RIGHT** buttons to select the image or movie. Press [**□**] to tag the image/movie to be protected. Press **SET** to confirm protection.

3.3.4 Playback Mode LCD Monitor Information (Video)

1. Video length
2. Video status bar
3. Video play position
4. File number
5. Video playback mode
6. Play/pause indicator



3.3.5 Playing Back Video Clips

Press the **SET** button to start playing back a video clip.

- Press the **SET** button to pause and resume video playback.
- Press the **▼** button to stop video clip playback.
- Press the **◀** button to start fast reverse playback.
- Press the **▶** button to start fast forward playback.





- **The zoom function cannot be activated while playing back video clips.**
- **To play back video clips on the computer, we recommend you to use Windows Media Player 9.0 (WMP 9.0). You can download the latest WMP version from the website at www.microsoft.com.**
- **Pressing the \square button in video playback mode changes the LCD display in the sequence of: Indicators on \rightarrow Indicators off.**

3.4 Setup Mode

This feature allows you to set up the default settings for your camera in addition to image-related settings. Select your personal preferences for the camera with this mode.

3.4.1 Setup Menus in Camera and Movie Mode

- Slide the mode switch to [] or [].
- Press the **MENU** button.
- Use the **UP/DOWN** buttons to select the desired item in the [Capture] menu, then press the **SET** button to view available settings for the item, or to view the submenu.
- Use the **UP/DOWN** buttons to select the desired setting and press the **SET** button to confirm.
- To exit from the menu, press the **MENU** button.

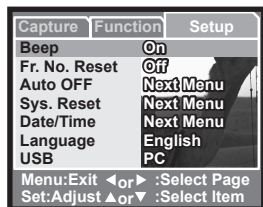

Item	Functional Description
BEEP	Enables or disables the sounds associated with camera button functions. <ul style="list-style-type: none"> - On - Off
FR. NO. RESET	Frame Number Reset resets the file number back to one (0001), and creates a new folder for files <ul style="list-style-type: none"> - Cancel - Execute.
AUTO OFF	If the camera goes unused for a certain period of time while the camera is powered on, it will switch to idle mode. If the camera is idle, re-activate it by pressing any button. <ul style="list-style-type: none"> - Off - 1 Min. - 2 Min. - 3 Min.
DATE/TIME	Sets the date and the time. Use the RIGHT button to enter the submenu. Use the UP/DOWN buttons to change date or time values. Use the LEFT/RIGHT buttons to change fields.
SYS. RESET	Returns all basic settings to the digital still camera's default settings. The time setting will not be reset. <ul style="list-style-type: none"> - Cancel - Execute
LANGUAGE	Sets the language that is displayed on the LCD monitor.
USB	Sets the USB functionality. <ul style="list-style-type: none"> - PC - Printer

3.4.2 Setup Menus in Playback Mode

1. Slide the mode switch to [▶].
2. Press the **MENU** button.
3. Use the **UP/DOWN** buttons to select the desired item in the [Capture] menu, then press the **SET** button to view available settings for the item, or to view the submenu.
4. Use the **UP/DOWN** buttons to select the desired setting and press the **SET** button to confirm.
5. To exit from the menu, press the **MENU** button.



Item	Functional Description
BEEP	Enables or disables the sounds associated with camera button functions. <ul style="list-style-type: none"> - On - Off
FORMAT	Erases all data and reformats the internal memory or the SD card loaded in your camera. Protected images are also erased. SD card cannot be formatted if it is write-protected. <ul style="list-style-type: none"> - Cancel - Execute
FR. NO. RESET	Frame Number Reset resets the file number back to one (0001), and creates a new folder for files <ul style="list-style-type: none"> - Cancel - Execute.
CARD INFO	This displays the free capacity of the SD card. If the SD card is not inserted, a "NO CARD" message is displayed on the screen.
SYSTEM INFO.	Displays the firmware version of the camera.
LANGUAGE	Sets the language that is displayed on the LCD monitor.
VIDEO OUTPUT	Sets the video output standard of the camera so you may connect your camera to video equipment. <ul style="list-style-type: none"> - PAL - NTSC

4 PC DEPENDENT FEATURES

4.1 Bundled Software

The DC E63+ is supplied with the following software:

Ulead Photo Express	Ulead® Photo Express™ 5.0 SE is a complete photo project software for digital images. Acquire photos effortlessly from digital cameras or scanners. Edit and enhance images using easy-to-use editing tools and cool photographic filters and effects. Assemble creative photo projects and share results via e-mail and multiple print options.
Ulead Photo Explorer	Ulead® Photo Explorer™ 8.0 SE Basic provides an efficient way to transfer, browse, modify and distribute digital media. It is the all-in-one tool for owners of digital cameras, webcams, DV camcorders, scanners, or for anyone striving to effectively handle digital media.
Ulead Video-Studio	Ulead® VideoStudio™ 8 SE VCD is home video editing software that makes editing movies as fun as shooting them. Users can make a movie in three easy steps using the new Movie Wizard mode. Share finished projects on VCD, tape, the web, and mobile devices.

To install the software, refer to the information supplied with respective CDs.

4.2 USB Mode

The DC E63+ can be connected directly to a computer using the supplied USB cable and files can be transferred between computer and camera. The camera can also function as a web cam, and can be used to print images directly to a compatible printer. The USB mode must be set accordingly.

1. Ensure that the USB mode has been set to PC. See “Setup Mode” on page 21.
2. Insert the conversion adapter into the conversion adapter terminal of the camera as shown in the illustration.
3. Connect the end of the smaller plug of the USB cable to the conversion adapter.
4. Connect the other end of the USB cable to an available USB port on your computer.
5. Turn on the camera. The [USB] screen is displayed.
6. A “Removable Disk” icon appears in “My Computer.” Click this icon to access recorded images/video clips/audio files.

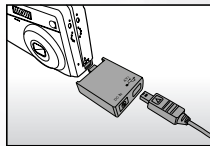

- **When connecting to the computer, it is necessary to install the battery or use an AC power adapter.**

4.3 Printer Mode

If a compatible printer is available, images can be printed without using a computer by connecting the digital still camera directly to the compatible printer.

4.3.1 Connecting the Camera to the Printer

1. Ensure that the USB mode has been set to Printer, see “Setup Mode” on page 21.
2. Connect the USB port on the camera and the USB jack on the printer using the supplied USB cable, then turn on your camera and the printer.
The “USB” screen is displayed.

4.3.2 Printing images

Images must be printed using the DPOF feature:

1. Connect the DC E63+ to the compatible printer as described above and ensure that the camera is in Playback mode.
2. Select an image to print and press the **MENU** button to display the Playback menu.
3. Use the **UP/DOWN** buttons to highlight the **DPOF** option and press the **SET** button to select it.



- Use the **UP/DOWN** buttons to select whether to print just the current (**Single**) image or **All** saved images, and press the **SET** button to confirm.
The DPOF settings menu is displayed

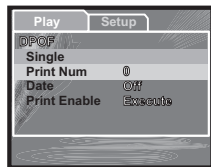

- Use the **UP/DOWN** buttons to highlight the **Print Num** option and press the **SET** button to confirm.
- Use the **UP/DOWN** buttons to set the number of prints and press the **SET** button to confirm.

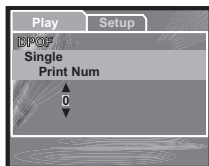

- Use the **UP/DOWN** buttons to highlight the **Date** option and press the **SET** button to confirm.
- Use the **UP/DOWN** buttons to set the **Date** function **On** or **Off** and press the **SET** button to confirm.

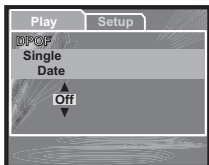



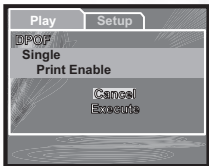





- Use the **UP/DOWN** buttons to highlight the **Print Enable** option and press the **SET** button to confirm.
- Use the **UP/DOWN** buttons to highlight the **Execute** option and press the **SET** button to confirm.
The selected pictures are printed.



5 TROUBLESHOOTING

Refer to the symptoms and measures listed below before sending the camera for repairs. If the problem persists, contact your local reseller or service center.

Symptom	Cause	Measure
The power does not come on.	There is no battery or the battery is not inserted correctly.	Insert the battery correctly.
	The battery has no power.	Recharge the battery or use the AC power adapter.
	The AC power adaptor is not connected correctly.	Connect it properly.
The battery runs out of power quickly.	It is being used in extremely low temperatures.	—
	Many shots are being captured in dark places, requiring a flash.	—
	The battery was not fully charged. The battery has not been used for an extended period of time after being charged.	Fully charge the battery and discharge it for at least one complete cycle before use to maximize its performance and lifetime.
The battery or camera feels warm.	The camera or flash was used continuously over a long period of time.	—
The flash does not fire.	The camera is set to  /  /  /  / AEB /  /  / TEXT /  /  / 	Switch the camera to a mode other than those listed.
The flash does not recharge.	The flash is set to no flash.	Set the flash to something other than no flash mode.
Even though the flash fired, the image is dark.	The distance to the subject is greater than the flash's effective range.	Get closer to the subject and shoot.
The image is too dark.	The image was captured in a dark place while set to no flash.	Set the flash to another mode.
	It is under-exposed.	Set the exposure compensation to a larger value.
The image is too bright.	The image is over-exposed.	Set the exposure compensation to a smaller value.

Symptom	Cause	Measure
The camera does not shoot even when pressing the shutter button.	The battery is running low.	Recharge or use the AC power adapter.
	The camera is not in shooting mode.	Slide the mode switch to shooting mode.
	The shutter button was not pressed all the way down.	Press the shutter button all the way down.
	The internal memory or memory card does not have any free space.	Load a new card or delete unwanted files.
	The flash is recharging.	Wait until the flash mode icon, indicated on the screen, stops flashing.
Cannot format a memory card.	The camera doesn't recognize the memory card.	Format the memory card in this camera before its first use or before using it with another camera.
	The memory card is write-protected. End of the memory card life.	Remove the write protection. Insert a new memory card.
Cannot download images.	There is insufficient free space on your computer's hard disk.	Ensure that the hard disk has space for running Windows and that the drive for loading image files has free space equal to or greater than the memory card in the camera.
	There is no power being supplied to the camera.	Turn the power on. Use the AC adapter or recharge the battery if need be.

6 SPECIFICATIONS

Image Sensor	1/2.5-inch 6.2 megapixel CCD
LCD Display	2.5-inch color LTPS LCD
Lens	Focal Length: $f = 5.4 - 16.2$ mm (32 mm - 96 mm; 35 mm Equivalent)
	F No.: F3.2~5.3
Focusing	TTL Auto Focus
	Range: Macro: 6 cm, Normal: 50 cm ~ infinity
Shutter	Mechanical shutter: Up to 1/1000 sec.
Flash	Modes: Auto / Forced flash / Red-eye reduction / Flash off /
	Range: 0.6 ~ 2.5m
Self-timer	10 sec/ 2 sec / 10 + 2 sec
Exposure	Compensation: ± 2 EV (0.5 EV / step)
ISO	Auto / 100 / 200
White Balance	AUTO / Incandescent / Fluorescent 1 / Fluorescent 2 / Day Light / Cloudy / Manual
File Format	Still Image: JPEG format (EXIF2.2, DCF, DPOF) Image Size: 2816 x 2112 / 2272 x 1704 / 1600 x 1200 / 640 x 480
	Movie Clips: ASF format with Continuous recording. Movie Size: 640x480 (30 fps), 320x240 (30fps)
Storage	Built-in memory: 10MB / SD Card compatible.
Interface (with conversion adapter)	Digital output: USB 1.1 DC input 5V AV output: NTSC/PAL
Power Source	Specified Rechargeable Lithium-ion Battery / AC adaptor.
Dimensions (WxHxD)	88.5 x 54.4 x 24 mm
Weight	Approx. 130 g (w/o battery, SD card)

6.1 System Requirements

- Pentium 166 MHz MMX class or higher CPU
- 64 MB RAM
- CD-ROM drive
- 128 MB free hard disk space
- Available USB port
- Windows XP/2000/ME

SERVICE INFORMATION

Technical Support

If you have any problems or questions regarding the DC E63+ or the camera driver, you can visit the following web site for further assistance:

<http://support.BenQ.com>

For free driver updates, product information and news releases, visit the following web site:

<http://www.BenQ.com>