

6. Some extra pen holders are provided for you. With these you can extend the arms and add more pens to make even more colourful patterns. You could add ball-point pens or coloured pencils instead of felt-tip pens. Please note: ask an adult's permission before you use other pens. They might wear out quickly because of the vibrations.

7. How about organising a Doodling Robot gala? Put two or three Doodling Robots on the same sheet of paper. Watch how they bump into each other and create interesting patterns. You could also put objects on the paper for the Robots to bump into.

8. Remove all the pens and turn down the arm ends. Doodling Robot becomes a vibrobot that slides across smooth surfaces.

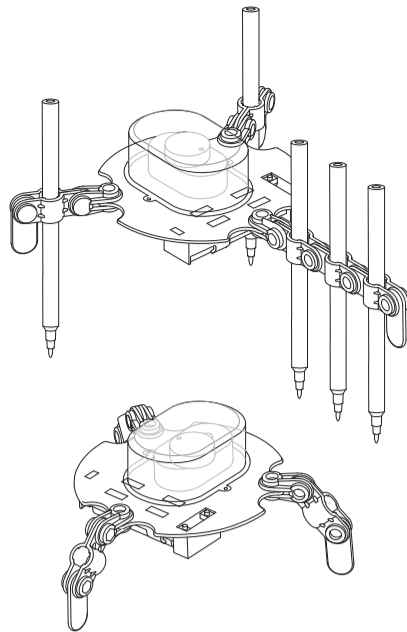

E. TROUBLE SHOOTING

If the motor does not run:

- Check that you are using fresh battery.
- Check that the battery are inserted the correct way round in the battery case.
- Check that the terminal caps are in properly, and that all four wires are touching the metal terminals.
- The vibrations can make the pens and arms move. Stop this by tightening the bolts in the arms a little.

G. HOW DOES IT WORK?

The batteries provide electricity to the motor, which turns the weight at high speed. The centre of gravity of the weight is off centre – it is not in line with the motor's shaft. As the weight moves around it pulls the baseplate in the opposite direction all the time, it makes the motor and baseplate vibrate in tiny circles at high frequency. It also makes the pen nibs vibrate up and down on the paper. As the nibs jump off the paper, the circling vibrations make them move along. If the nibs did not jump up and down, friction with the paper would stop them from moving.

H. FUN FACTS

- Industrial robots that move, cut and join materials can be programmed to draw on paper.
- Swiss scientists have built a robot that takes a picture of a person's face and uses it to draw a sketch of the person using a pen on a robot arm.
- Turtle educational robots can be programmed to draw geometric shapes using simple programming language, such as FORWARD, BACK and TURN.
- Vibrations are used in many industrial machines. For example, vibrating conveyors move materials such as powders by making them jump up and down at high frequency.

FUN MECHANIC SERIES

You will like the other great Fun Mechanic kits:



00-03272 Smart Robot

A smart robot which changes its moving path when it hits an obstacle. No remote control or programme chips. It just moves as if it has a brain.



00-3282 Brush Robot

A robot that scuttles along on a brush. It's powered by rapid vibrations from its motor. Brush robot that will sweep you away!



00-03270 Tin Can Robot

Millions of soda cans are being wasted daily. Help recycle one of them and turn it into a cool robot which walks in silly movement when it is turned on. It could be turned to a robot monster too. Just cool.



00-03273 Bottle Catamaran

Construct a cool catamaran with this unique science project. Watch your catamaran skim across the water on its pop-bottle floats, pushed by its spinning propeller. Recycle two plastic bottles to make its floats. It's a fun mechanical kit and a recycling project too.

Questions & Comments

We value you as a customer and your satisfaction with this product is important to us. If you have comments or questions, or you find any part of this kit missing or defective, please do not hesitate to contact our distributor in your country. You will find the address printed on the package. You are also welcome to contact our Marketing Support Team: Email: infodesk@4m-ind.com, Fax: (852) 25911566, Tel: (852) 28936241, Web site: WWW.4M-IND.COM

©2009 4M Industrial Development Limited. All rights reserved.

DOODLING ROBOT

To Parents: Please read through these instructions before giving guidance to your children.



A. SAFETY

1. Adult supervision and assistance are required at all times.
2. This kit is intended for children of ages over 8.
3. This kit and its finished product contain small parts which may cause choking if misused. Keep away from children under 3 years old.
4. To prevent possible short circuits, never touch the contacts inside the battery case with any metal.

B. USE OF THE BATTERY

1. Requires one 1.5V "AA" battery (not included).
2. For best results, always use a fresh battery.
3. Make sure you insert the battery with the correct polarities.
4. Remove the battery from the kit when not in use.
5. Replace an exhausted battery straight away to avoid possible damage to the kit.
6. A rechargeable battery must be removed from the kit before recharging.
7. Rechargeable batteries should be recharged under adult supervision.
8. Do not attempt to recharge non-rechargeable batteries.
9. Make sure that the supply terminals in the battery case are not short circuited.

C. CONTENTS

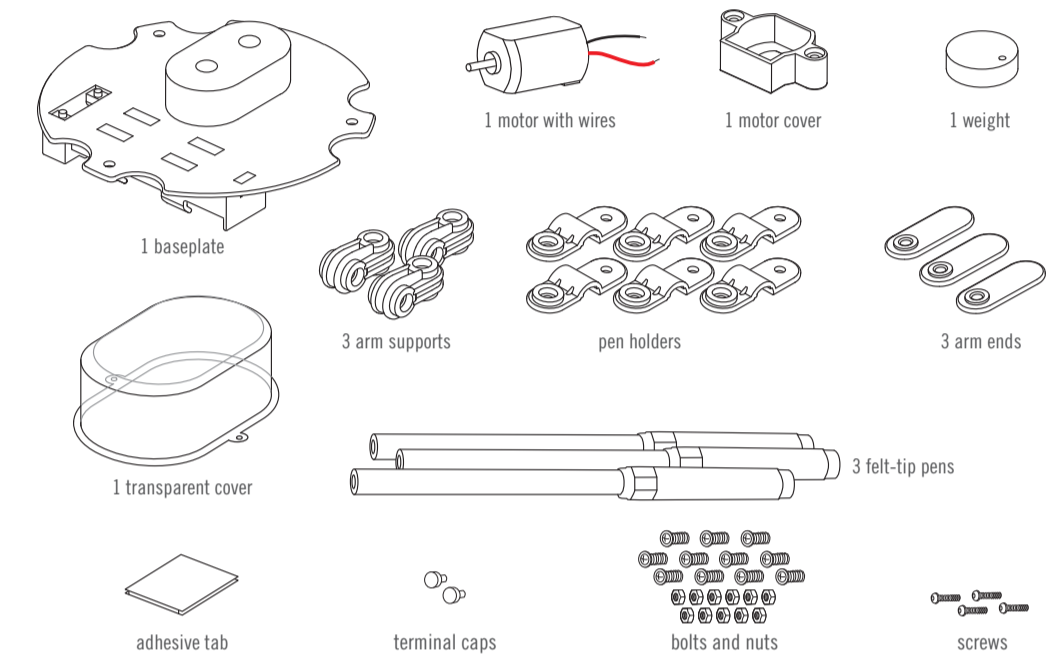

Also required but not included: 1 x 1.5V "AA" battery, small crosshead screwdriver, large sheets of paper.

D. ASSEMBLY

1. Examine the baseplate. The underside is the side with the battery case. There are two slots for the motor on this side. Push the motor into the slot in the centre of the baseplate, spindle first. Make sure that the small metal ring around the motor's spindle fits right into the hole in base of the slot.

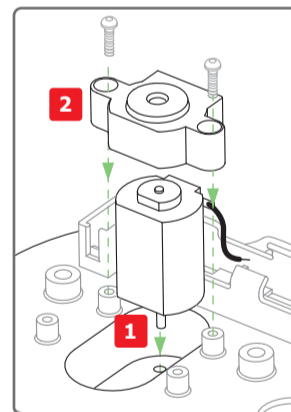

2. Fit the motor cover over the motor, with the square side over the wire connections. Secure the cover with two screws.

3. The weight has a small hole on its underside. Push the small hole over the motor's spindle.

4. The Robot Doodler has three arms connected to the rim of the baseplate. Push one end of an arm support over a hole in the edge of the baseplate. Secure the support with a nut and bolt. The arm should be tightly attached to the plate but you should still be able to turn it from side to side. Attach the other two arm supports to the other holes on the baseplate.

5. Hold two halves of a pen holder together and slot the narrow ends into one of the arm supports. Push a bolt through the holes in the pen holder and the arm support and put a nut on the bolt. Tighten the bolt until the joint is tight but can still move. Add a pen holder to the other two arm supports.

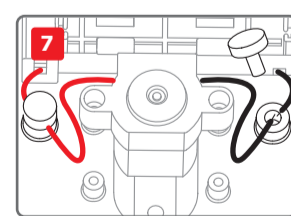

6. Then add an arm end to the end of each arm, and secure them with nuts and bolts.

7. Now you need to connect the wires from the battery to the wires from the motor. There are two terminal holes on the underside of the baseplate. Push the bare ends of the red wire from the battery case and the red wire from the motor into one hole. Push a terminal cap into the hole to trap and connect the wires. Repeat with the black wires in the other terminal hole.

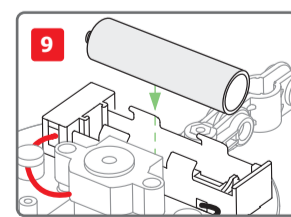

8. Put the transparent cover over the weight and secure it with two screws into the holes in the baseplate.

9. Insert a 1.5 V "AA" battery into the battery case. The negative terminal (the flat end) of the battery goes against the spring in the battery case. If the motor runs, switch the switch to turn it off.

10. Push a felt-tip pen into the pen holder in each of the arms. The nibs of the pens must point down, so they must be on the underside of the baseplate (where the battery is).

Congratulations! Your Doodle Robot is ready to draw!

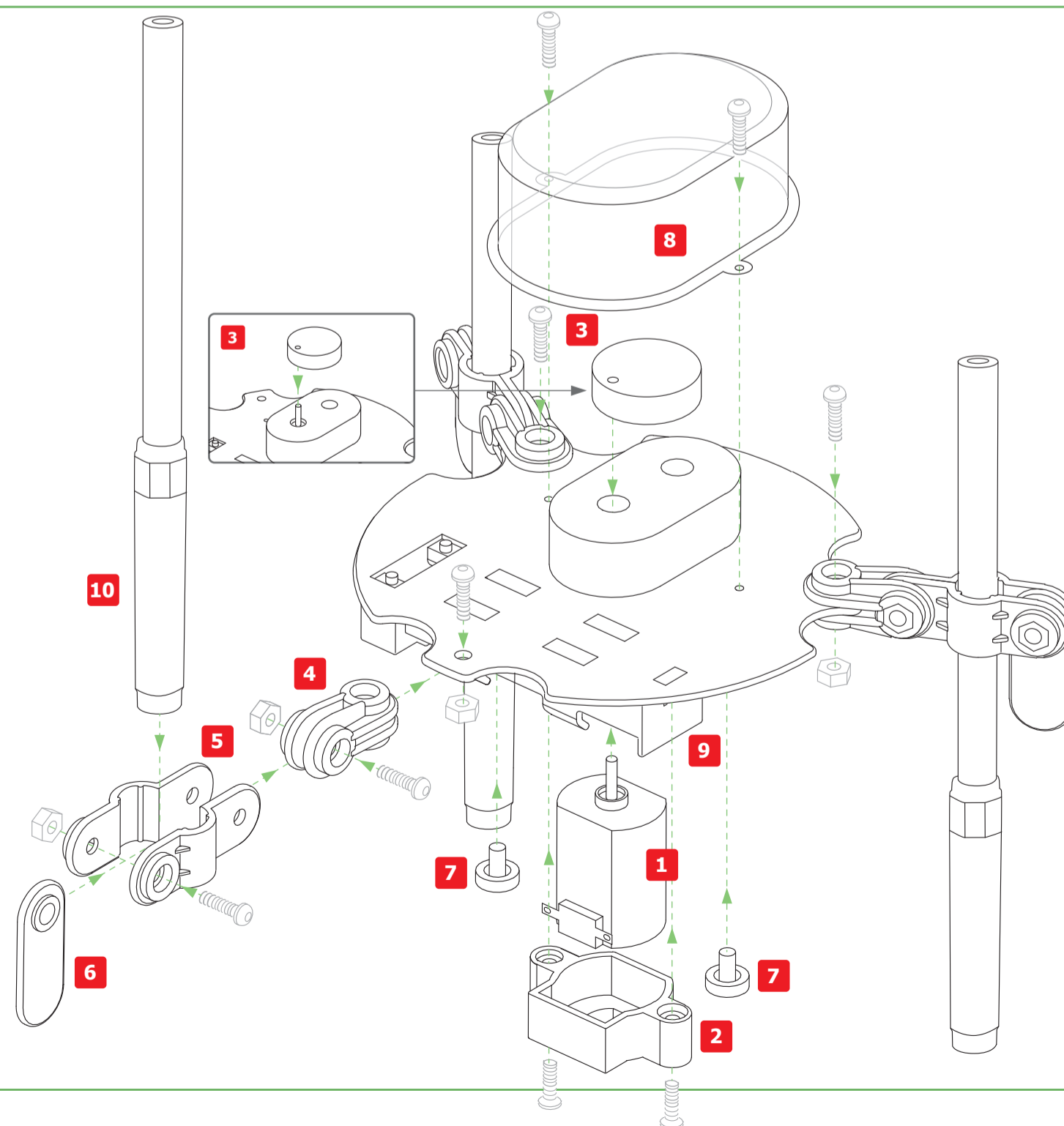

E. OPERATION

Always cover your working area with sheets of newspaper so that the working surface is not stained by ink if the Doodling Robot leaves the drawing paper. Place a large sheet of drawing paper (or newspaper if you like) on the working area. Using the adhesive pads provided, put strips of paper along the edges of the drawing paper, creating a border. This will stop the Doodling Robot from leaving the paper.

1. To draw a circle line pattern: Check that the arms are all pointing straight outwards and are level, so that the pens are vertical. Remove the pen caps and switch on the motor. Gently put the Robot Doodler onto a large sheet of paper and let it go. It should move in a circle, drawing three coloured lines. When you are happy with the pattern the Robot Doodler has drawn, lift the Robot off the paper. Switch off the motor and replace the pen caps. You can also fix one of the pens to the drawing paper with an adhesive pad. The Robot will revolve around this pen, drawing larger circles with its other two pens.

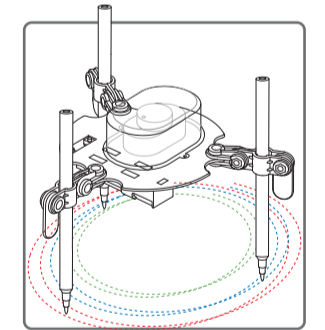

2. To draw straight line patterns: Turn the pen holders so that they are all parallel, and tilt the pens slight outwards (see diagram). The Robot should run along a straight line, drawing lines as it goes.

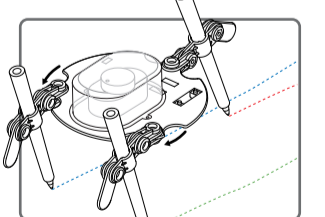

3. Try installing the motor in the other slot (which is off centre in the baseplate). Your Doodling Robot will tend to spin in a more unpredictable way than when the motor is in the centre, and will draw a more random pattern.

4. Try adjusting the height of the baseplate by moving the pens up and down in their holders. Doodling Robot will spin faster if the baseplate is higher and slower if it is lower.

5. Try different combinations of angles of the pen holders. You might make Doodling Robot draw some new and interesting patterns. There are endless possibilities.